

Revell U-Boat Type IX C (U 505 late)

05114-0389

© 2013 by Revell GmbH. A subsidiary of Hobbico, Inc.

PRINTED IN GERMANY



U-Boat Type IX C (U 505 late)

Das erste U-Boot vom Typ IX C wurde am 2. Januar 1941 von der Kriegsmarine übernommen. Insgesamt wurden 54 Boote von diesem Typ bis 1942 gebaut. Die ursprüngliche Bewaffnung bestand aus einer 10,5-cm-Seezielkanone (180 Schuss) auf dem Vordeck, einer 2-cm-Flak (4.250 Schuss) auf der Turmplattform und einer 3,7-cm-Flak (2.500 Schuss) an Deck hinter dem Turm. Die Besatzung bestand aus vier Offizieren und 44 Mannschaften.

U 505 wurde als Baunummer 295 der Deutschen Werft in Hamburg am 12. Juni 1940 auf Kiel gelegt und am 26. August 1941 von Kptlt. Loewe in Dienst gestellt. Die Ausbildungs- und Erprobungsfahrten in der Ostsee waren am 19. Januar 1942 beendet. Auf der ersten Feindfahrt verlegte das Boot zur 2. U-Flottilie nach Lorient an der französischen Atlantikküste. Die folgenden zwei Unternehmungen vor Westafrika und in der Karibik dauerten bis zum 5. September 1942 und erbrachten sieben Versenkungen. Auf der vierten Feindfahrt unter dem neuen Kommandanten Oblt.z.S. Zschech wurde in der Karibik östlich Trinidad am 7. November 1942 ein britischer Frachter von 7.124 BRT versenkt. Drei Tage später erhielt das aufgetauchte fahrende Boot bei einem Angriff einer britischen Lockheed Hudson einen Wasserbomben-Volltreffer. Die Explosion führte zu schweren Schäden und zwang U 505 zur Rückfahrt.

Im Frühjahr 1943 erhielt U 505 im Rahmen von Umbaumaßnahmen den Turm III mit „großen Wintergarten“. Die obere Plattform bestückte man mit zwei 2-cm-Fia-Zwillingkanonen. Auf der tiefer gelegenen Plattform kam die 3,7-cm-Flak vom Achterdeck zur Aufstellung. Die 10,5-cm-Seezielkanone wurde abmontiert. Wiederholte Sabotageakte französischer Werftarbeiter verhinderten das Auslaufen zur fünften Feindfahrt. Auf der sechsten Fahrt nahm sich Kptlt. Zschech am 24. Oktober 1943 während eines Wasserbomben-Angriffs bei den Azoren das Leben, was zum Abbruch der Fahrt führte. Unter dem neuen Kommandanten Oit. Lange rettete U 505 auf seiner siebten Fahrt 33 Mann von in der Biskaya versenkten Schnellbooten. Am 16. März 1944 lief U 505 mit einer überwiegend neuen und unerfahrenen Besatzung zur achten Feindfahrt aus. Am 4. Juni 1944 stellte die Task-Group 22.3 der US Navy, bestehend aus dem Geleitträger USS Guadalcanal und fünf Zerstörern, U 505 im Mittelatlantik, 150 Seemeilen nordwestlich von Dakar und beschädigte es durch Wasserbomben. Es gab Wassereintrüche im Maschinenraum und am Heck. Die Besatzung öffnete ein Flutventil und sprang von dem aufgetauchten langsam weiter fahrenden Boot, das mit MG und Flak beschossen wurde. U 505 sank jedoch nicht schnell genug und konnte erbeutet, wieder schwimmfähig gemacht und zu den Bermudas geschleppt werden.

Das U-Boot wurde ausgiebig von der US Navy getestet und 1954 an das Museum of Science and Industry in Chicago übergeben. Seit 2005 ist das überwiegend in Originalzustand restaurierte Tauchboot in einem neu errichteten Gebäude des Museums zu besichtigen.

Technische Daten U 505:

Länge: 76,76 m, Breite: 6,76 m, Tiefgang: 4,67 m, Wasserverdrängung: 1.120 t (aufgetaucht) / 1.540 t (getaucht), Dieselantrieb: 2 x 9-Zylinder-4-Takt-Dieselm 109V 40/46 (gesamt 4.400 - 5.000 PS), Elektrischer Antrieb: 2 x SSW GU 345/34 (gesamt max. 1.000 PS), Höchstgeschwindigkeit: 18,3 kn (aufgetaucht) / 7,3 kn (getaucht), Reichweite aufgetaucht: 13.450 sm (bei 10 kn) / 5.000 sm (bei 18,3 kn), Reichweite getaucht: 63 sm (bei 4 kn), Tauchtiefe: 200 m, Zerstörungs-Tauchtiefe: 250 m, Torpedos: 4 Torpedo-Rohre im Bug / 2 im Heck

U-Boat Type IX C (U 505 late)

The first type IX C submarine was taken over by the German Navy on 2nd January 1941. In total 54 subs of this class had been built by 1942. The original armament consisted of one 105 mm (surface/surface) cannon (180 rounds) on the foredeck, one 20 mm anti-aircraft gun (4,250 rounds) on the tower platform and one 37 mm anti-aircraft gun (2,500 rounds) on the deck aft of the tower. The crew consisted of four officers and 44 men.

The keel of U 505 was laid down at the German shipyards at Hamburg on 12th Jun 1940 under yard no. 295 and she went into service under Kapitl. Loewe on 26th August 1941. The training and test voyages in the Baltic Sea ended on 19th January 1942. For her first combat operation, the sub moved to the 2nd U Flotilla at Lorient on the French Atlantic coast. Her next two operations off West Africa and in the Caribbean lasted until 5th September 1942 and achieved seven sinkings. On her fourth combat operation in the Caribbean east of Trinidad, under a new commander Oblt.z.S Zschech, on 7th November 1942 she sank a British 7,124 GRT freighter. Three days later the surfaced sub was attacked by a British Lockheed Hudson and received a direct hit from a depth charge. The explosion caused serious damage and forced U 505 to withdraw.

In the spring of 1943, during modifications, U 505 received tower III with a large conning tower. The top platform was equipped with two 20 mm twin-barreled anti-aircraft guns. On the lower platform the 37 mm anti-aircraft gun from the after deck was mounted. The 105 mm surface/surface gun was removed. Repeated sabotage actions by French shipyard workers prevented the launch for the fifth combat operation. On her sixth mission Kptlt. Zschech took his own life during a depth charge attack on 24th October 1943 off the Azores, which cut short the operation. On her seventh mission, under her new commander Oit. Lange, U 505 rescued 33 men from torpedo boats sunk in the Bay of Biscay. On 16th March 1944, U 505 set out on her eighth mission with a mainly new and inexperienced crew. On 4th June 1944 US Navy Task Group 22.3, consisting of the convoy escort vessel USS Guadalcanal and five destroyers, intercepted U 505 in the mid Atlantic 150 sea miles north west of Dakar and damaged her with depth charges, causing water ingress in the engine room and stem. The crew opened a flood valve and jumped out of the slow moving surfaced submarine which was under fire from machine guns and anti-aircraft guns. However U 505 did not sink fast enough, so they were able to capture her, make her seaworthy again and tow her to the Bermudas.

The submarine was thoroughly tested by the US Navy and in 1954 she was handed over to the Museum of Science and Industry in Chicago. Since 2005 it has been possible to visit this submarine, which has been restored almost to her original condition, in a new building at the museum.

Technical data, U 505:

Length: 76.76 m, Beam: 6.76 m, Draught: 4.67 m, Displacement: 1,120 tons (surfaced) / 1,540 tons (dived), Diesel power: 2 x 9-cylinder, 4-stroke M9V 40/46 diesel engines (total 4,400 - 5,000 hp), Electric power: 2 x SSW GU 345/34 (max. total 1,000 hp), Top speed: 18.3 knots (surfaced) / 7.3 knots (dived), Range surfaced: 13,450 sea miles (at 10 knots) / 5,000 sea miles (at 18.3 knots), Range dived: 63 sea miles (at 4 knots), Dive depth: 200 m, Destruction dive depth: 250 m, Torpedoes: 4 torpedo tubes in the bow / 2 stern

Form hergestellt und im Eigentum von Revell GmbH. Widersätzliche Nachahmungen werden gerichtlich verfolgt.

Ce produit est propriété de la société Revell GmbH. Toute utilisation ou duplication frauduleuse fera l'objet de poursuites en justice.

Modelado y en propiedad de Revell GmbH. Imitaciones ilícitas serán perseguidas por la ley.

Forma prodotta dalla Revell GmbH e di proprietà della stessa impresa, la quale procederà legalmente contro ogni imitazione abusiva.

Modell an Revell GmbH valmistama ja omaisus. Laittoomien kopiointiin tullaan puuttamaan oikeudellisten toimin.

Design utviklet av og eies av Revell GmbH. Etterligning uten tillatelse blir gjenstand for rettslig forfølgelse.

Produkt jeo je pravo vlasnosti firmy Revell GmbH. Nielegalne podrobienie jest zabronione pod odpowiedzialnoscia sadowa.

Model, Revell GmbH firmasinin mülkiyeti altında imal edilmiştir. Kanunla aykırı taklitler mahkemeye takip edilcektir.

A forma előállításja és tulajdonjog bírkozása Revell GmbH. A jogellenes utánzások és hamisítványok bírósággal üldözök.

Model manufactured by and property of Revell GmbH. Illegal imitations are subject to prosecution.

Vorm vervaardigd door en eigendom van Revell GmbH. Onrechtmatige nabootsingcn worden gerechtelijk vervolgd.

Formas produzidas e de propriedade da Revell GmbH. Cópias não autorizadas serão processadas juridicamente Como determinado na lei.

Modellcn tillverkad av och tillhör Revell GmbH. All kopiering beivras enligt lagen om upphovsrätt.

Formen er fremstillet af Revell GmbH som også har ejendomsret. Lovstridige efterligninger sagsages.

Модель изготовлен и принадлежит собственности фирмы Revell GmbH. Противозаконные подделки преследуются и оштрафуются в судебном порядке.

Η μορφή κατασκευαστηκε και περιηλθε ιδιοκτησια της Revell GmbH. Οι παρανομες μιμησεις θα καταδικωνται δικαστικως.

Tvar byl vyvoren firmou Revell GmbH a je jejim vlastnictvim. Prati nezakonnym napodobenim se bude postupovno soudni castou.

Forma je proizvedena i je vlasništvo Revell GmbH. Neovlaštne kopije bodo pravno kaznjene.

Verwendete Symbole/Used Symbols

Bitte beachten Sie folgende Symbole, die in den nachfolgenden Baustufen verwendet werden.
 Veuillez noter les symboles indiqués ci-dessous, qui sont utilisés dans les étapes suivantes du montage.
 Sivane tener en cuenta los símbolos facilitados a continuación, a utilizar en las siguientes fases de construcción.
 Si prega di fare attenzione ai seguenti simboli che vengono usati nei susseguenti stadi di costruzione.
 Huomioi seuraavat symbolit, joita käytetään seuraavissa kokoonamisvaiheissa.
 Legg merke til symbolene som benyttes i monteringsstapene som følger.
 Proszę zwrócić na następujące symbole, które są użyte w poniższych etapach montażowych.
 Daha sonraki montaj besamaklarında kullanılmak üzere, aşağıdaki sembollere lütfen dikkat edin.
 Kérjük, hogy a következő szimbólumokat, melyek az alábbi építési fázisokban alkalmazásra kerülnek, vegyétek figyelembe.

Please note the following symbols, which are used in the following construction stages.
 Neen u.a.b. de volgende symbolen in acht, die in de onderstaande bouwfasen worden gebruikt.
 Por favor, preste atenção aos símbolos que seguem pois os mesmos serão usados nas próximas etapas de montagem.
 Observe: Nedanstående piktogram används i de följande arbetsmomenten.
 Læg venligst mærke til følgende symboler, som benyttes i de følgende byggefaser.
 Пожалеуйста, обратите внимание на следующие символы, которые используются в последующих операциях сборки.
 Παρακαλώ προσέξτε τα παρακάτω σύμβολα, τα οποία χρησιμοποιούνται στις παρακάτω βαθμίδες συναρμολόγησης.
 Dbejte prosim na dále uvedené symboly, které se použijí v následujících konstrukčních stupních.
 Prosimo za Vašu pozornost na sledeće simbole ki se uporabljajo v naslednjih korakih gradbe.



Kleben
Glue
Coller
Lijmen
Engomar
Colar
Incollare
Limmas
Limmaa
Klebbing
Lim
Клеить
Przykleić
κόλλημα
Yapıştırma
Lepení
ragasztani
Lepiti



Nicht kleben
Don't glue
Ne pas coller
Niet lijmen
No engomar
Não colar
Non incollare
Limmas ej
Älä limmaa
Må ikke klebes
Ikke lim
Не клеить
Nie przyklejać
μη κολλάτε
Yapıştırılmayın
Nelepit
nem szabad ragasztani
Ne lepiti



Anzahl der Arbeitsgänge
Number of working steps
Nombre d'étapes de travail
Het aantal bouwstappen
Número de operaciones de trabajo
Número de etapas de trabalho
Numero di passaggi
Antal arbetsmoment
Työvaiheiden lukumäärä
Antal arbetsförlopp
Antal arbeidstrinn
Количество операций
Liczba operacji
αριθμός των εργασιών
İş safhalarının sayısı
Počet pracovních operací
A munkafolyamatok száma
Števila koraka montaže



Abziehbild in Wasser einweichen und anbringen
Soak and apply decals
Mouiller et appliquer les décalcomanies
Transfer in water even laten weken en aanbrengen
Remojat y aplicar las calcomanías
Pôr de molho em água e aplicar o decalque
Immergere in acqua ed applicare decalcomanie
Blöt och fäst dekaler
Kostuta siirtokuvaa vedessä ja aseta paikat/oen
Overføringsbilledet lægges i båd og anbringes
Dypp bildet i vann og sett det på
Перевозимую картинку намочить и нанести
Zmęczyć kalkomanie w wodzie a następnie nakleić
βουτήξτε τη χαλκομανία στο νερό και τοποθετήστε τη
Çikartmayı suda yumuşatın ve koyun
Obisk namočite ve vodě a umíst'te
a matricát vízben beáztatni és felhelyezni
Preslikač potopiti v vodu in zatem nanašati



Zur Anbringung der Abziehbilder empfohlen
Recommended for affixing the decals
Recommandé pour l'application des décalcomanies
Aanbevelen voor het aanbrengen van de transfers
Recomendado para fijar las calcas
Posição recomendada para aplicar os decalques
Recomandato per applicare le decalcomanie
Recomendareaş für montarea de decalor
Anbefales til påsætning og placering af decal
Рекомендуется использовать для фиксации переводных картинок на поверхность модели
Zalobano do nanosenia kalkomanii
Συνιστάται για την επικόλληση των εκπτώσεων.
Dekalerin yarıp girilmesinde kullanılmamas tavsiye edilir
Připravak na zlepení přinavosí oběsků
Matrica lagytó
Připravte ji na přilepení nalepek
Odpovídání ne zlepenie přinavosí nalepek
RECOMANDAT PENTRU APLICAREA ACTIILORILOR
Παρακάλει za fixacijski na kartinih pri uporabi na modelu



Klebeband
Adhesive tape
Détail de ruban adhésif
Plakband
Cinta adhesiva
Fita adesiva
Nastro adešivo
Tejp
Teippi
Tape
Tape
Клейкая лента
Tasma klejaca
κόλλητική ταινία
Yapıştırma bandı
Lepící páska
ragasztószalag
Traka z lepilom



Bautelle trocken lassen
Allow the parts to dry
Laisser sécher les pièces
Dejar secar las piezas
Deixar secar os componentes
la delene tørre
Oderdelen laten drogen
Far asciugarsi i componenti
Anna osien kuivua
Låt byggdelarna torka
Lad komponenterne tørre
Czesci pozostawic do wyschniecia
Yapı parçalarını kurumaya bırakınız
Jednotlivé díly nechte zaschnout
Αφήστε τα μέρη να στεγνώσουν
Alkatrészeket hagyja száradni
Pustite da sestavni deli posušijo
Дать деталям высохнуть

1.

Zusammenbau-Reihenfolge
Sequence of assembly
Ordre d'assemblage
Volgorde van montage
Orden de montaje
Ordine di montaggio
Orden de montagem
Monteringsrækkefølge
Kokoonisjärjestys
Monteringsföjrd
Rækkefølgen af monteringen
Последовательность монтажа
Összeszerelési sorrend
Ακολουθία συναρμολόγησης
Kurmak-Sıra
Kolejność montażu
Vrstni red sestavljanja
Montáž - postup



Wahlweise
Optional
Facultatif
Naar keuze
No engomar
Alternado
Facoltativo
Valfrtt
Valtöhtöisästi
Efter eget valg
Valgrtt
Ha vlybor
Do wyboru
εναλλακτικά
Sermeli
Voiteinle
tetszés szerinti
način izbire



Gleichen Vorgang auf der gegenüberliegenden Seite wiederholen
Repeat same procedure on opposite side
Opérer de la même façon sur l'autre face
Dezelfde handeling herhalen aan de tegenoverliggende kant
Realizar el mismo procedimiento en el lado opuesto
Repetir o mesmo procedimento utilizado no lado oposto
Stessa procedura sul lato opposto
Upprepa proceduren på motsattida sidan
Toista sama toimenpide kuten vieriselällä sivulla
Det samme arbejdet gentages på den modsatte liggende side
Gjenta prosedyren på siden tvrs overfor
Повторит такую же операцию на противоположной стороне
Taki sam przebieg czynności powtórzyc na stronie przeciwnej
επαναλάβετε την ίδια διαδικασία στην απέναντι πλευρά
Aynı işlemleri karşı tarafta tekrarlayın
Stejný postup zopakovat na protilehlé straně
ugyanazt a folyamatot a szemben található oldalán megismételni
Isti postopeki ponoviti in na suprotni strani



Abbildung zusammengesetzter Teile
Illustration of assembled parts
Figure représentant les pièces assemblées
Afbecding van samengevoegde onderdelen
Ilustración piezas ensambladas
Figura representando peças encaixadas
Illustrazione delle parti assemblate
Bilden visar delarna hopsettia
Kuva yhteennitetyistä osista
Illustration af sammensatte dele
Ilustrasjon, sammensatte deler
Изображение смонтированных деталей
Rysunek zlozonych czesci
απεικόνιση των συναρμολογημένων εξαρτημάτων
Bilésítitlen parçaların şekli
Zobrazení sestavených dílů
őszedlitott alkatrészek ábrája
Silka siopjanega dela



Loch bohren
Make a hole
Faire un trou
Maak een gat
Practicar un taladro
Perfurar
Fare un foro
Borra hål
Poraa reikä
Der bores et hul
Bor hull
Просверлить отверстие
wywiercić otwór
ανοίξετε τρύπα
Delik açın
Vyvrťte dírú
lyukat fúrni
Narediti lukinjo



Anknoten und Kleben
Tie and Glue
Attacher et Colier
Vastknoten en Lijmen
Atar y Engomar
Anudar e Colar
Annodare e incollare
Knyt fast och Limmas
Solmi ja Limmas
Bindes fast og Klebbing
Knyt og Lim
Связать узлом и Клеить
Przywiązać oraz Przykleić
κομποδέστε και κόλλημα
Düğümleyin ve Yapıştırma
Nauzlit a Lepení
megcsomósztani és ragasztani
Zavezati in Lepiti



Mit einem Messer abtrennen
Detach with knife
Détacher au couteau
Met een mesje afsnijden
Separarlo con un cuchillo
Separar utilizando uma faca
Staccare col coltello
Skär loss med kniv
Irota veitsellä
Adskilles med en kniv
Skjør av med en kniv
Отделить ножом
Odciać nożem
διαχωρίστε με ένα μαχαίρι
Bir bıçak ile kesin
Oddélit pomocí nože
kés segítségével leváaszítani
Oddeilit z nožem

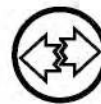

Entfernen
Remove
Détacher
Verwijderen
Sacar
Retirar
Eliminare
Tag loss
Poista
Fjernes
Fjern
Удалить
Usunąć
απομακρύνετε
Távolítsayin
Odsraniti
eltávolítani
Ostraniti



Schwarzen Faden benutzen
Use black thread
Employer le fil noir
Gebruik zwarte draad
Utilizar hilo color negro
Utilizar filo preto
Usare filo nero
Använd svart trådar
Käytä mustaa lankaa
Bruyt en sort
Bryk svart
Использовать черные нитки
Uzyc czarnej nici
χρησιμοποιήστε την καφέ μαύρου
Kahvöngi siyah ipik kullanın
Použit černé vlákno
barna fekete fonalat kell használni
Uporabljati črni nit



Nicht enthalten
Not included
Non fourni

Behoort niet tot de levering
No incluido
Non compresi

Não Incluído
Ikke medsendt
Ingår ej

Ikke inkluderet
Eivát sisálly
Δεν συμπεριλαμβάνεται

He содержится
Nem tartalmazza
Nie zawiera

Ni vsebovano
Ikke indeholdt
Nem tartalmazza
Neni obsazeno

D: Beiliegenden Sicherheitstext beachten und nachschlagebereit halten.

GB: Please note the enclosed safety advice and keep safe for later reference.

F: Respecter les consignes de sécurité ci-jointes et les conserver à portée de main.

NL: Houdt u aan de bijgaande veiligheidsinstructies en hou deze steeds bij de hand.

E: Observar y siempre tener a disposición este texto de seguridad adjunto.

I. Seguire le avvertenze di sicurezza allegate e tenerle a portata di mano.

P: Ter em atenção o texto de segurança anexo e guard-ilo para consulta.

S: Beakta bifogad säkerhetstext och håll den i beredskap.

FIN: Huomioi ja säilytä ohjeiset varoitukset.

DK: Overhold vedlagte sikkerhedsanvisninger og hav dem liggende i nærheden.

N: Ha alltid vedlagt sikkerhetstekt klar til bruk.

RUS: Сохранять прилагаемый текст по технике безопасности, хранить его в легко доступном месте.

PL: Stosować się do załączonej karty bezpieczeństwa i mieć ją stale do wglądu.
GR: ποσέτε τις συνημνές υποδείξεις ασ άλειας και υλέξετε τις ται όστε να τις χτε πάντα σε διαό ση σας.

TR: Ekteki güvenliik talimatlarını dikkate alıp, bakabileceğiniz bir şekilde muafaza ediniz.

CZ: Dbejte na příložen' bezpečnostní text a mŕjte jej pfiilpraven' na dosah.

H: A mellékelt biztons-gi szöveget vegye figyelembe és tartsa fellapoz-sra készen!

SLO: Prilöena varnostna navodila izvajajte in jih hranite na vsem dostopnem mestu.

Benötigte Farben/Used Colors

Benötigte Farben Required colours	Peintures nécessaires Benodigde kleuren	Pinturas necesarias Tintas necessárias	Colori necessari Använda färger	Tarvittavat värit Du trenger følgende farger	Nødvendige farger Необходимые краски	Potrzebne kolory Απαιτούμενα χρώματα	Gerekli renkler Potrebne barvy	Szükséges színek Potrebne barve
A	B	C	D	E	F			
blaugrau, matt 79 greyish blue, matt gris-bleu, mat blauwgrijs, mat gris azulado, mate cinzento azulado, fosco grigio blu, opaco blågrå, matt sinharmaa, himmeä blågrå, mat blågrå, matt сине-серый, матовый siwy, matowy γκριζομπλέ, ματ mavi gri, mat modrosédá, matná kékecsszürke, matt plavo siva, mat	anthrazit, matt 9 anthracite grey, matt anthracite, mat antraciet, mat antracita, mate antracite, fosco antracite, opaco antracit, matt antrasitti, himmeä koksgrå, mat antrasitt, matt антрацит, матовый antracyt, matowy ανθρακί, ματ antrasit, mat antracit, matná antracit, matt tamno siva, mat	panzergrau, matt 78 tank grey, matt gris blindé, mat pantsergrijs, mat plomizo, mate cinzento militar, fosco color carro armado, opaco pansargrå, mat panssarinharmaa, himmeä kampvogngrå, mat pansergrå, matt серый танк, матовый szary czolg., matowy γκρι πανκς, ματ panzer grisi, mat pancéřové šedá, matná páncéřszürke, matt okloпно siva, mat	teerswarz, matt 6 tar black, matt noir tartre, mat teerzwart, mat negro alquitrán, mate alcitrão, fosco nero catrame, opaco asfaltsvart, matt tervanmusta, himmeä tjæresort, mat tjæresort, matt смолисто-черный, матовый czarny-smoła, matowy μαύρο πίσσας, ματ katran siyahı, mat dehtové černá, matná kátrányfekete, matt ter črna, mat	karminrot, matt 36 carmin red, matt rouge carmin, mat karmijnrood, mat carmin, mate vermelho carmin, fosco rosso carminio, opaco karminrød, matt karmiininpunainen, himmeä karminrød, mat karminrød, matt красный кармин, матовый karminowy, matowy κόκκινο δαϊήδω, ματ lâl rengi, mat krbové červená, matná kárminpiros, matt šminka rdeča, mat	seegrün, matt 48 sea green, matt vert d'eau, mat zeegroen, mat verde mar, mate verde-mar, fosco verde lago, opaco havsgrün, matt merenvihreä, himmeä havgrøn, mat sjøgrønn, matt зеленый морской, матовый zieleń morska, matowy πράσινο λίμνης, ματ göl yeşili, mat mořská zelená, matná tengerzöld, matt morsko zelena, mat			
G	H	I						
eisen, metallic 91 steel, metallic coloris fer, métallique ijzerkleurig, metallic ferroso, metalizado ferro, metálico ferro, metallico järnfärg, metallic teräksenvärinen, metallikiitto jern, metallak jern, metallic стальной, металл żelazo, metaliczny σιδηρού, μεταλλικό demir, metalik železná, metaliza vas, metál železna, metalik	messing, metallic 92 brass, metallic laiton, métallique messing, metallic latón, metalizado latão, metálico ottone, metallico mässing, metallic messinki, metallikiitto messing, metallak messing, metallic латунный, металл mosiądz, metaliczny ορείχαλκου, μεταλλικό pirinç, metalik mosazná, metaliza sárgaréz, metál mesing, metalik	grau, matt 57 grey, matt gris, mat grijs, mat gris, mate cinzento, fosco grigio, opaco grå, matt harmaa, himmeä grå, mat grå, matt серый, матовый szary, matowy γκρι, ματ gri, mat šedá, matná szürke, matt siva, mat						

Dieser Bausatz wurde in mehrfachen Qualitäts- und Gewichtskontrollen auf Vollständigkeit überprüft. Reklamationen können nur bearbeitet werden, wenn die **Bauanleitung**, das aus der Kartonage herausgeschnittene **EAN-Strichcode-Feld** und der **Kassenbon** eingeschickt werden. Bitte haben Sie Verständnis dafür, dass wir nur Gewährleistung bei aktuellen Artikeln übernehmen können, die im Zeitraum der letzten 24 Monate erworben worden sind. **Unfrei eingesandte Reklamationssendungen werden von uns nicht angenommen!**

„Einzelteile für Umbauten können gegen Vorkasse erworben werden“. Unsere Adresse: Revell GmbH, Abteilung X, Henschelstr. 20-30, D-32257 Bünde. Dieser Direktservice gilt für die Länder: Deutschland, Benelux, Österreich, Frankreich, Großbritannien. Reklamationen aus den übrigen Ländern werden über die jeweiligen Distributeure abgewickelt. Bitte kontaktieren Sie Ihren Händler.

This Model Kit has been subject to extensive quality and weight checks during the manufacturing process to ensure it leaves our warehouse in perfect condition. We are only able to process applications for missing parts if the following procedure is followed. In all cases the following will be required before we are able to process any request: Original receipt (proof of purchase) original instruction sheets (will be returned) and the bar code cut out of the box. We may not be able to process requests for products that have been discontinued for more than 24 months. Products that are returned directly to us without prior authorisation by a company representative will not be accepted and returned to sender. Replacement parts for conversion or spares will continue to be available however they will incur a handling charge. Please write to: Department X Revell GmbH, Henschelstr 20-30, D-32257 Bünde.

This direct service is only available in the following markets: Germany, Benelux, Austria, France & Great Britain, Revell GmbH, Orchard Mews, 18c High Street, Tring Herts. HP23 5AH, Great Britain.

For all other markets please contact your local dealer or distributor directly.

Afin de vous donner entière satisfaction et pour nous assurer que tous les éléments nécessaires au montage de votre maquette sont présents dans la boîte, cet article a subi dans son intégralité divers contrôles qualitatifs ainsi que des contrôles de poids.

Si toutefois vous deviez nous faire part de certaines réclamations, nous vous prions de bien vouloir vous adresser à votre revendeur habituel, muni de la notice de montage, du code EAN découpé sur la boîte, ainsi que de votre ticket de caisse.

Le SAV ne sera assuré que pour les articles ayant été acquis depuis moins de 24 mois.

Les pièces de rechange utilisées pour la transformation de maquettes pourront être obtenues en pré-paiement. Dans le cas où vous n'obtiendriez pas satisfaction, vous pouvez vous adresser directement à notre service SAV à l'adresse suivante: REVELL GmbH, Abteilung X, Henschelstraße 20-30, D-32257 Bünde ou Revell GmbH, 14 B, rue du Chapeau Rouge, F-21000 Dijon, France.

Pour tous les autres marchés, merci de prendre contact avec votre détaillant ou distributeur.

Deze bouwdoos werd verscheidene malen volledig gecontroleerd op kwaliteit en gewicht. Klachten kunnen slechts in behandeling worden genomen indien de bouwhandleiding, de uit de doos geknipte EAN-streepjescode en de kassabon zijn meegezonden. Wij vragen om uw begrip dat wij alleen garantie kunnen geven voor huidige artikelen die binnen een periode van de laatste 24 maanden zijn gekocht. Onvolledig ingezonden klachten kunnen niet in behandeling worden genomen. Onderdelen voor ombouw kunnen tegen vooruitbetaling gekocht worden.

Ons adres is: Revell GmbH, Afdeling X, Henschelstrasse 20-30, D-32257 Bünde, Duitsland. Deze directe service geldt alleen voor de volgende landen: Duitsland, Benelux, Oostenrijk, Frankrijk, Groot Brittannië.

Klachten afkomstig uit overige landen worden via de eventuele lokale vertegenwoordigers van Revell afgewikkeld. Wij verzoeken U contact op te nemen met uw winkelier.

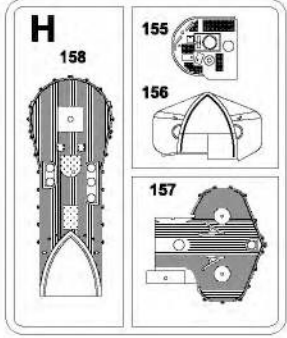
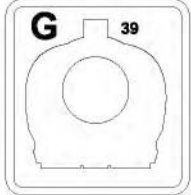
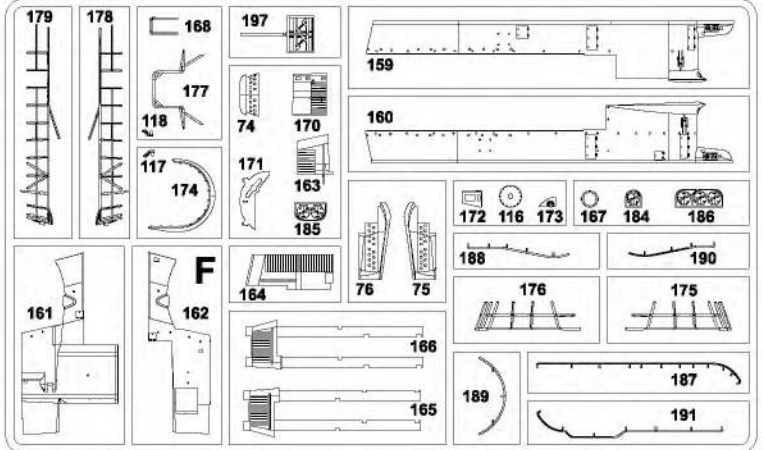
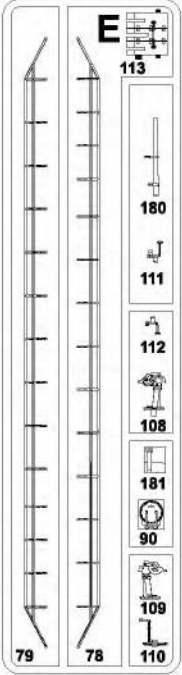
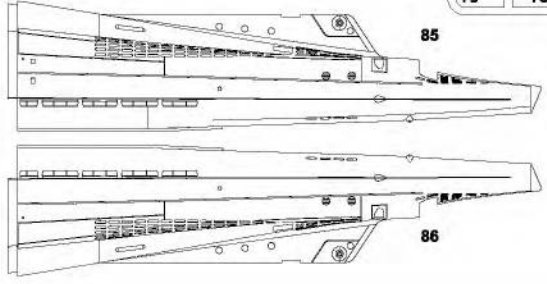
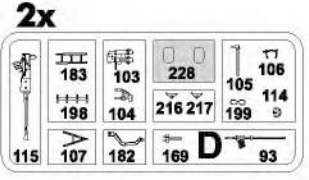
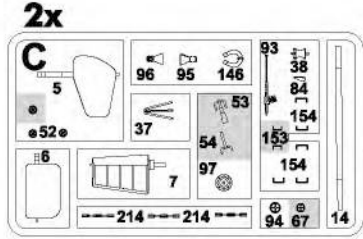
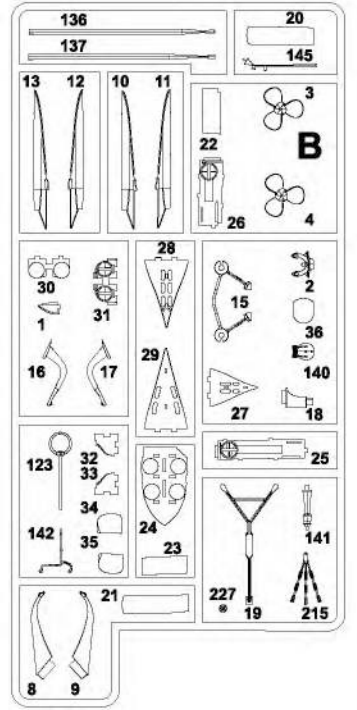
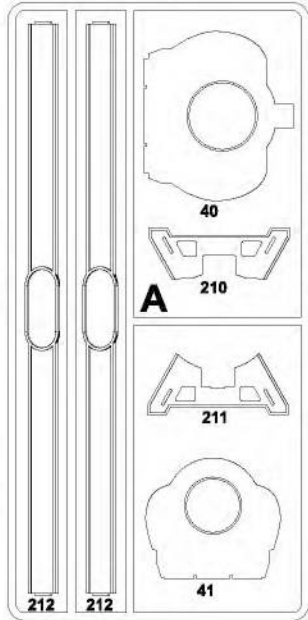
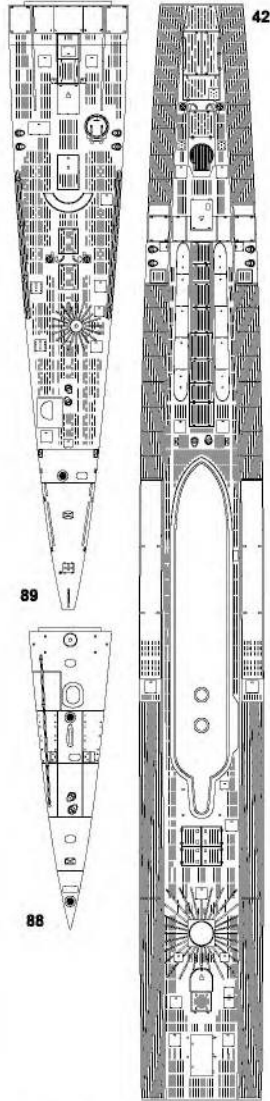
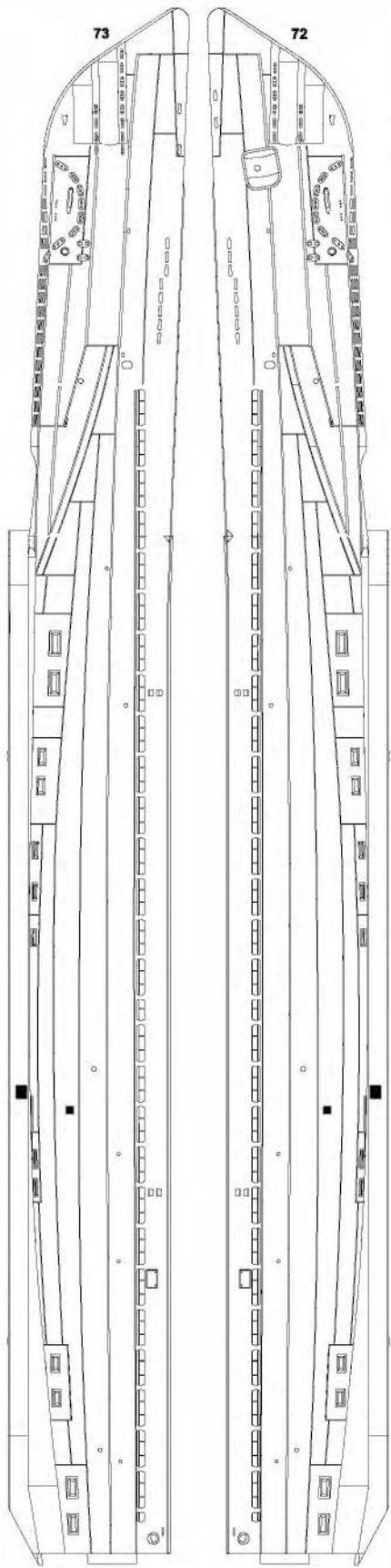

Nicht benötigte Teile
 Parts not used
 Pièces non utilisées
 Niet benodigde onderdelen
 Piezas no necesarias
 Peças não utilizadas
 Partii non usate
 Inte använda delar
 Tarpeettomat osat
 Ikke nødvendige dele
 Deleer som ikke er nødvendige
 Неиспользованные детали
 Elementy niepotrzebne
 Gereksiz parçalar
 Nepotřebné díly
 fel nem használt alkatrészek
 Nepotrebni deli

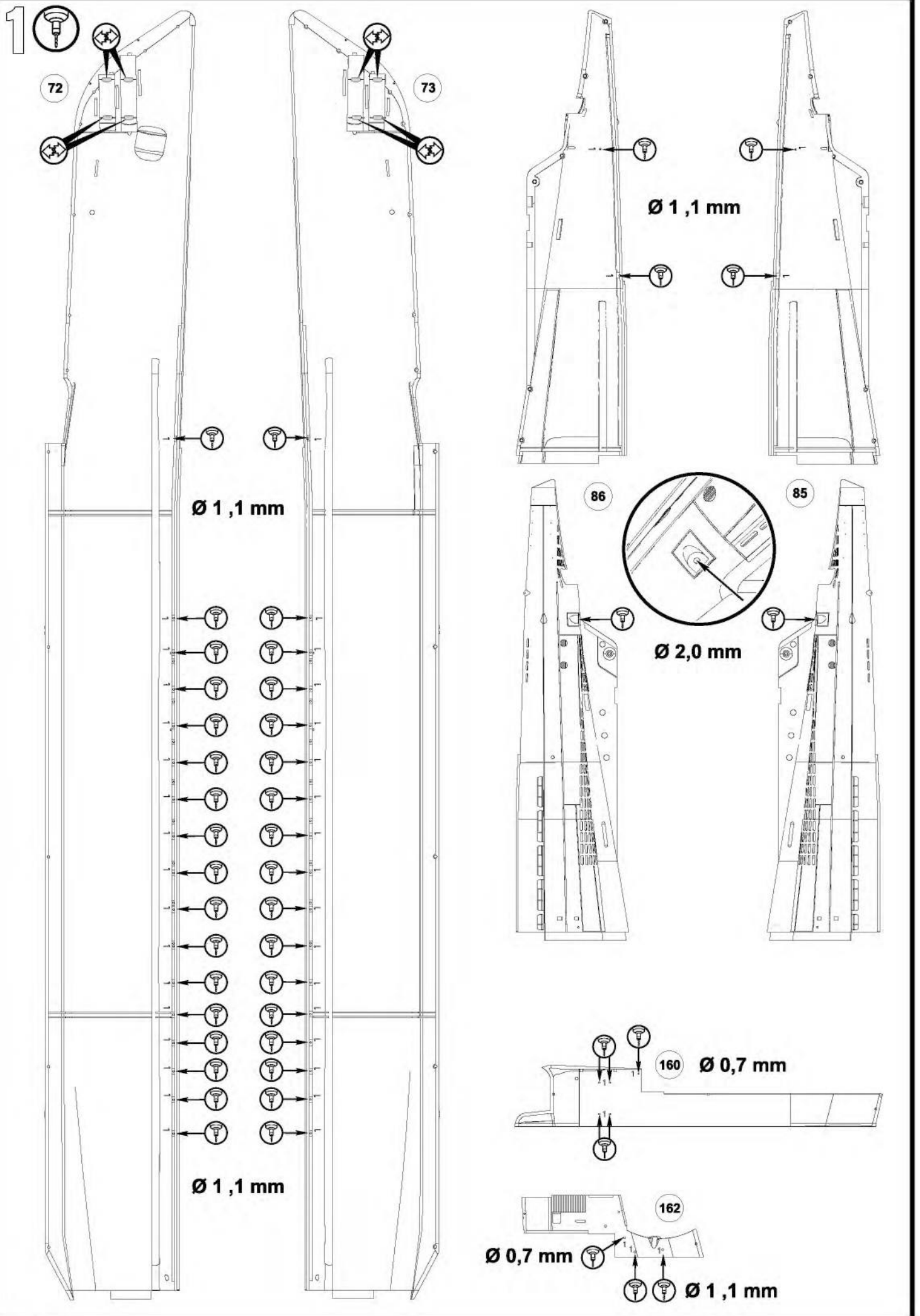

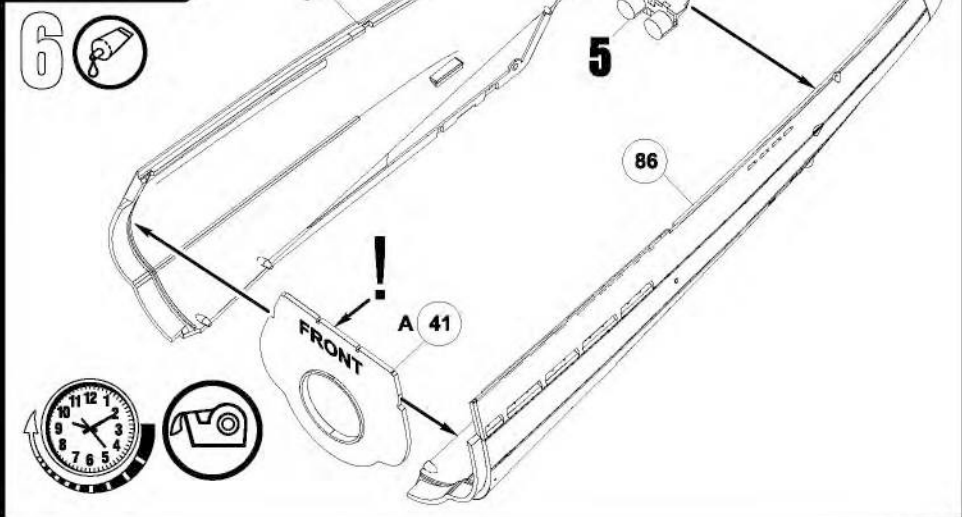
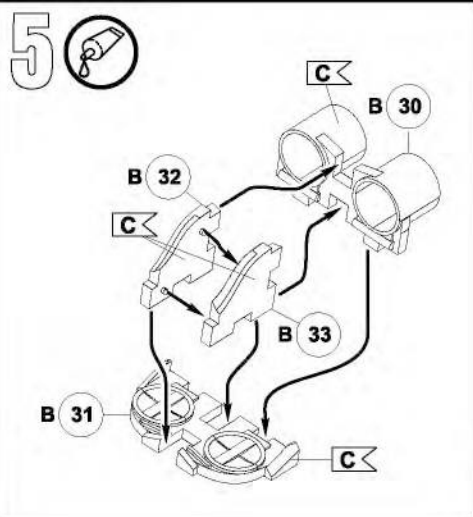
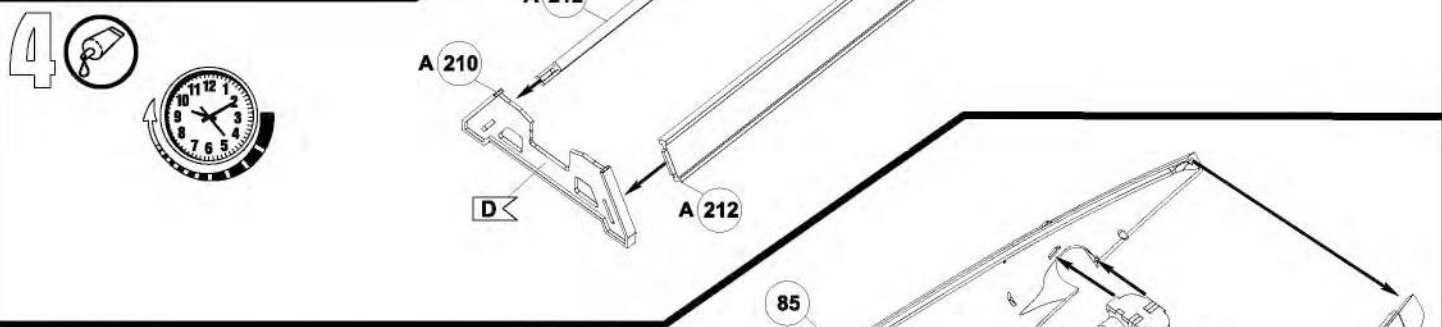
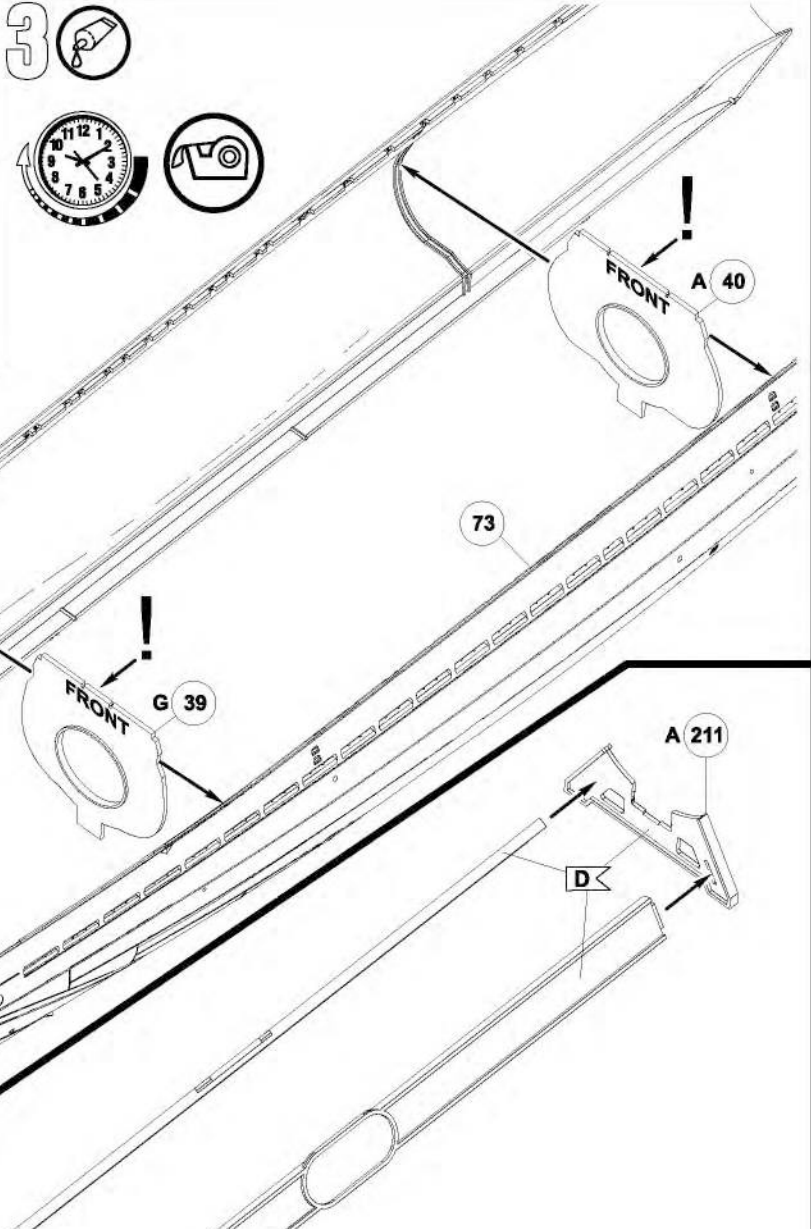
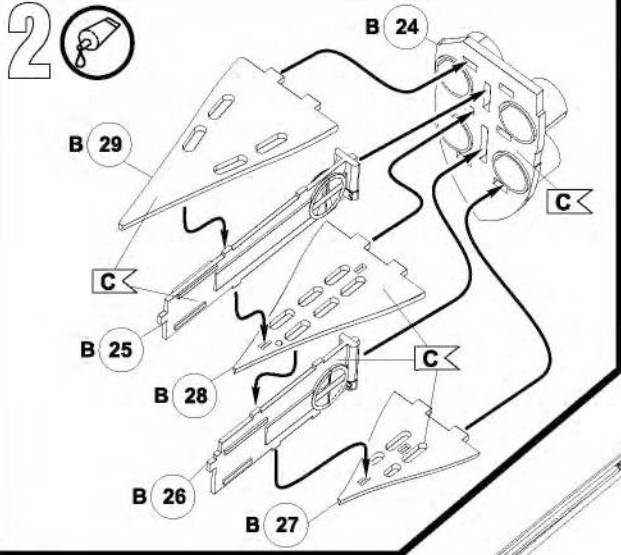

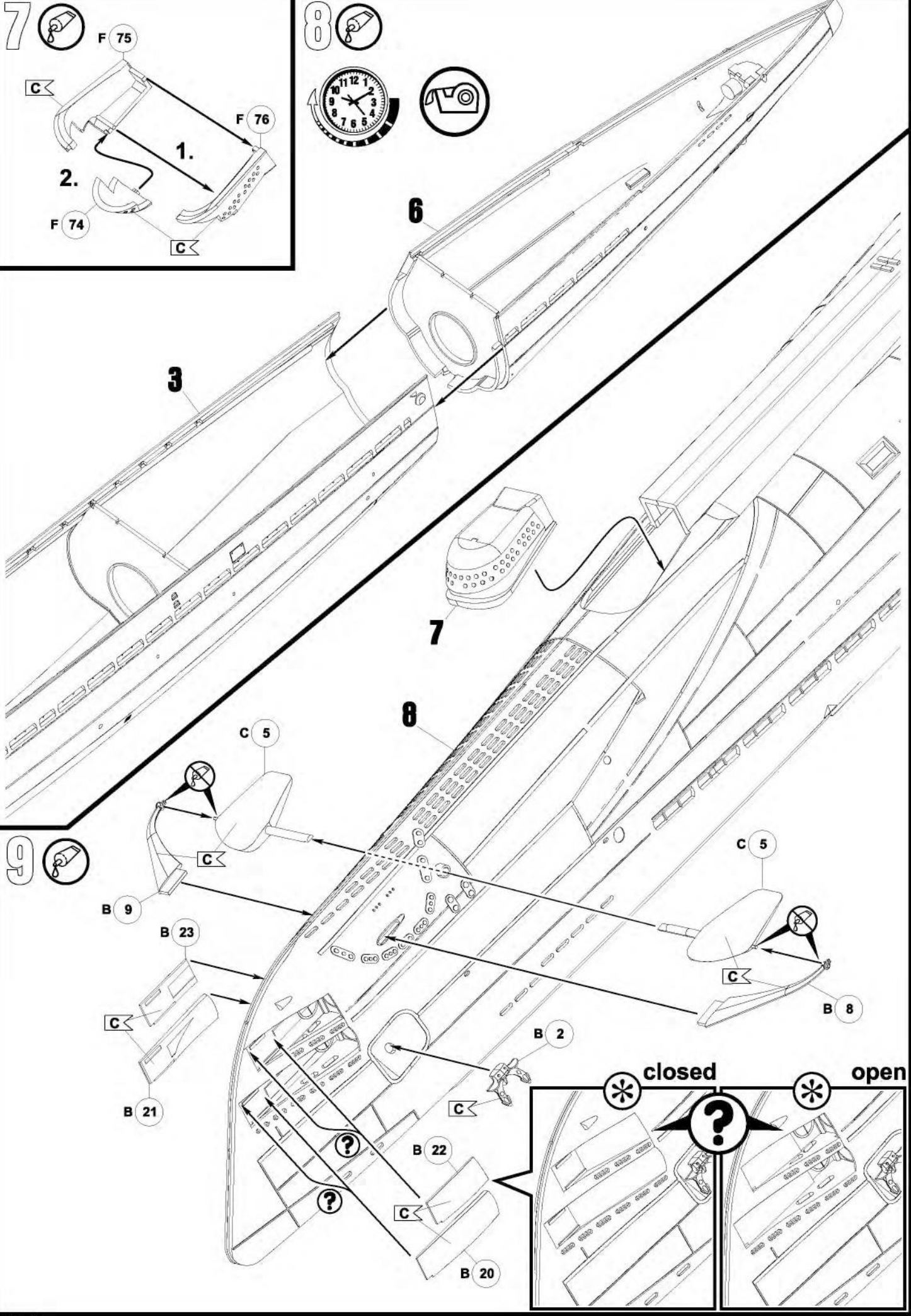
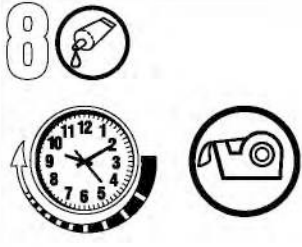
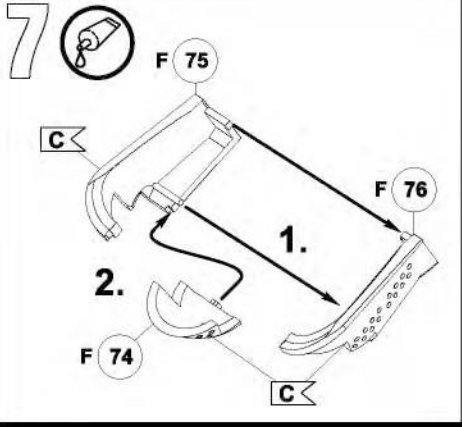

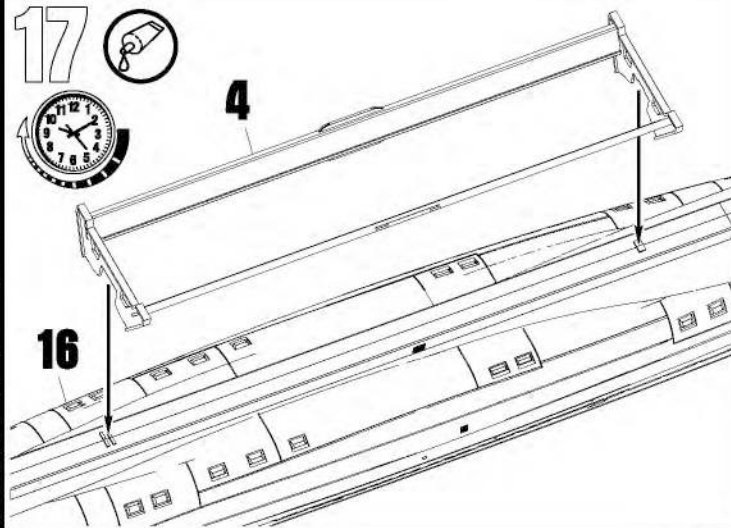
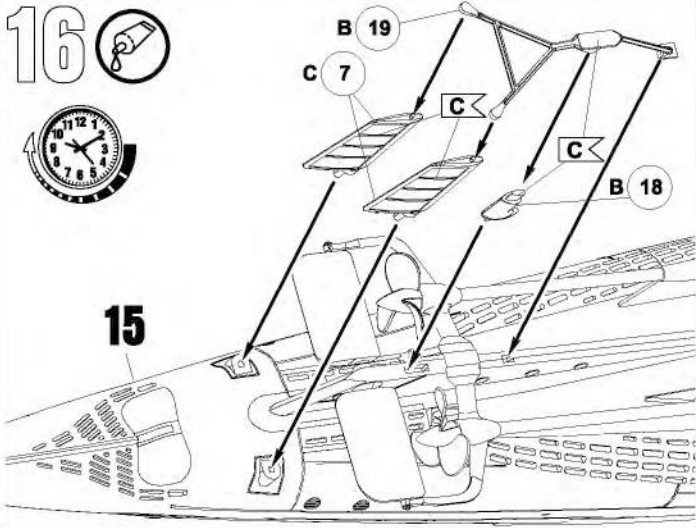
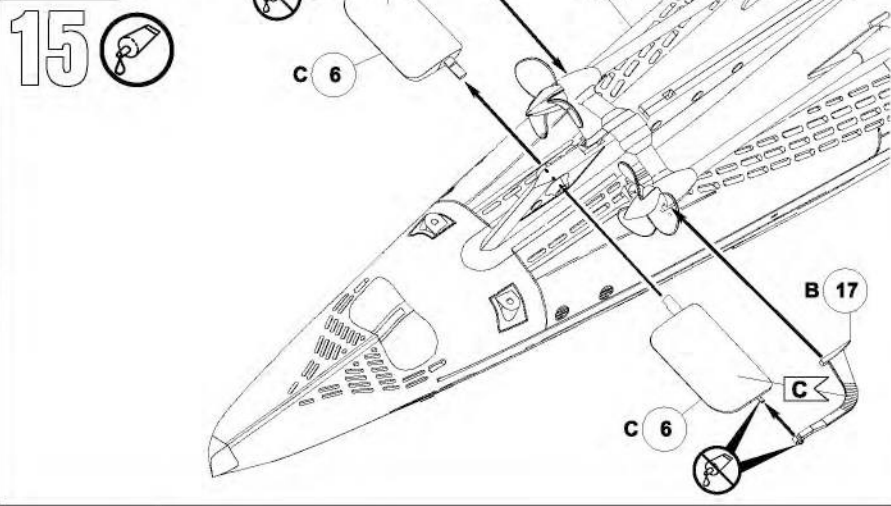
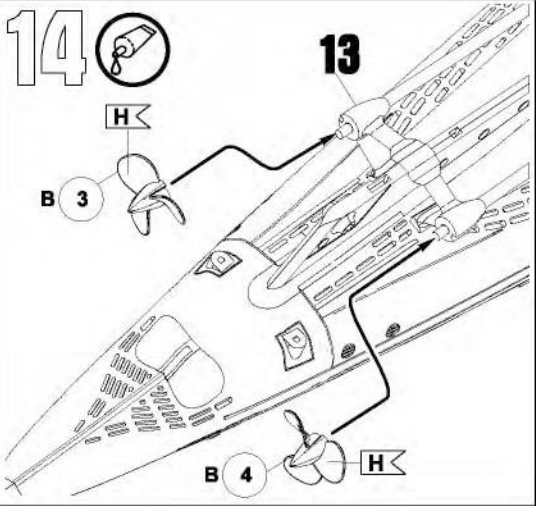
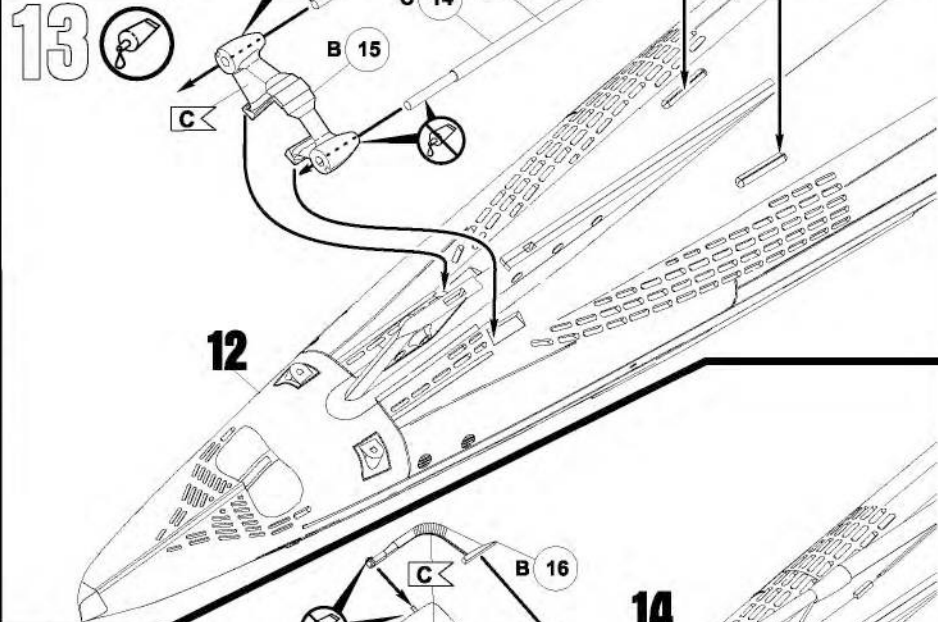
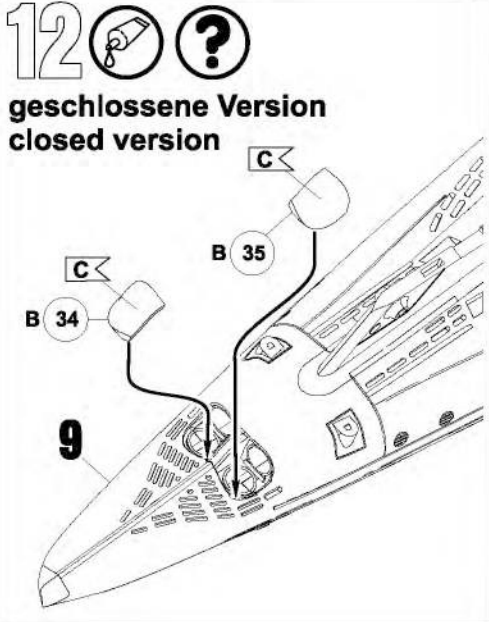
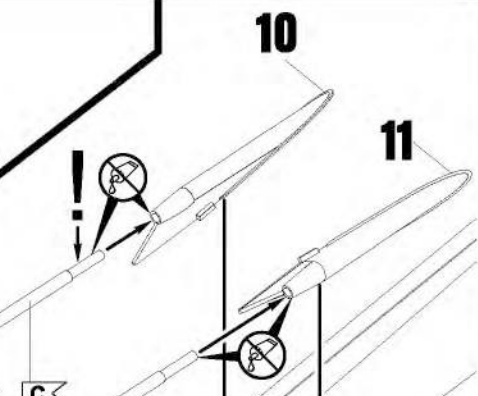
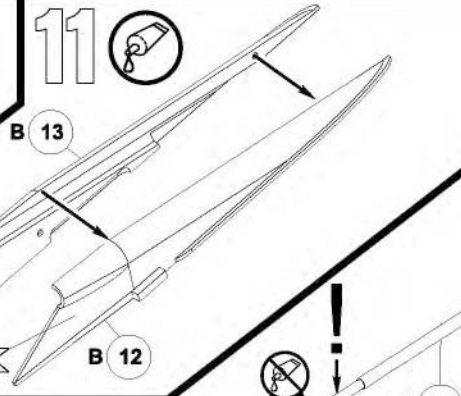
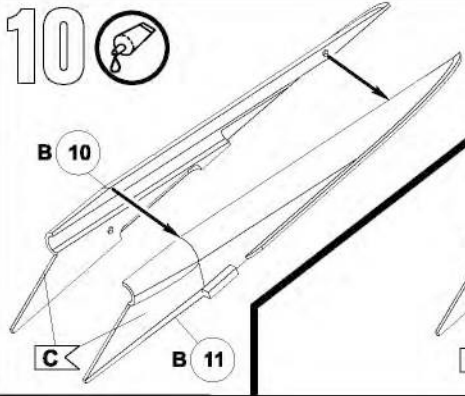

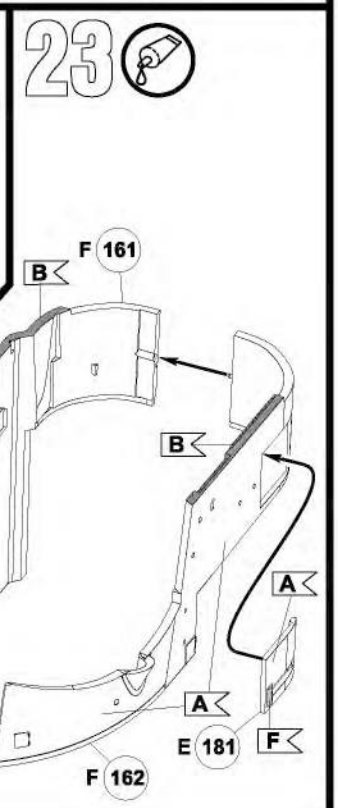
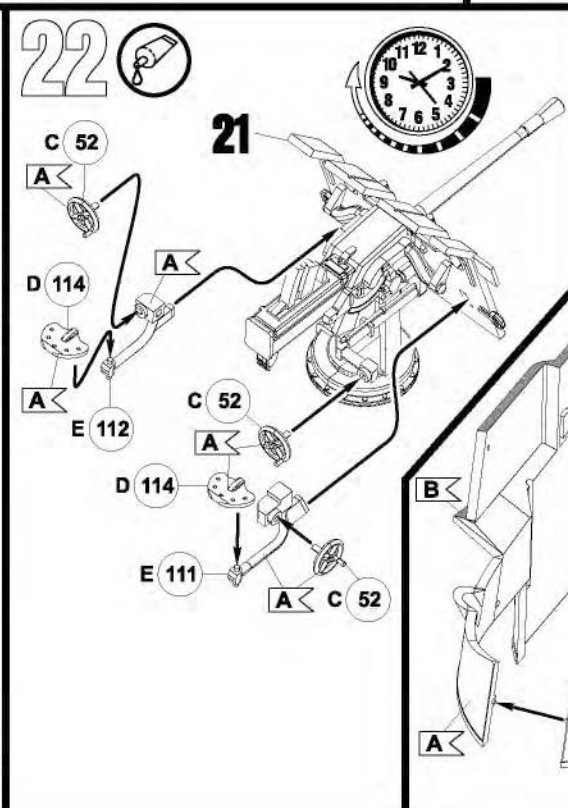
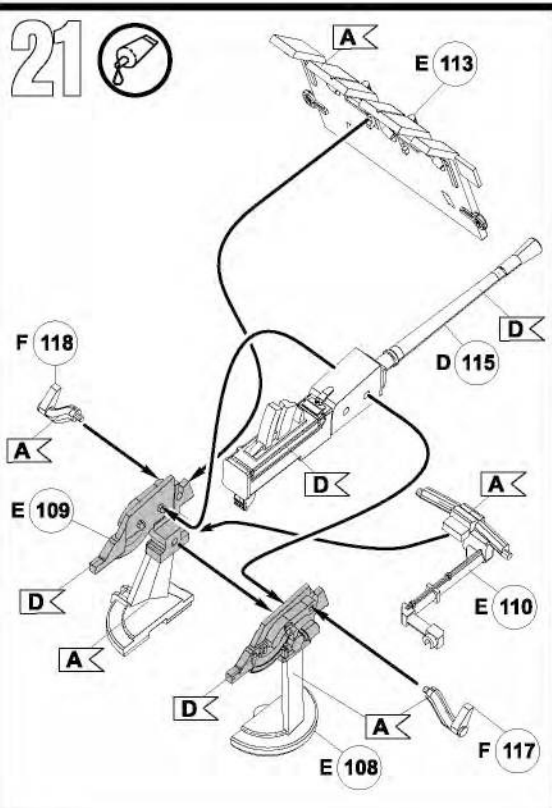
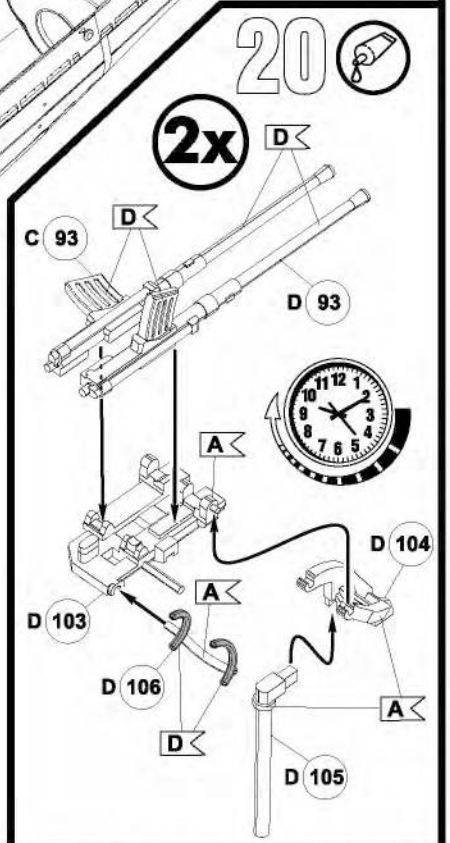
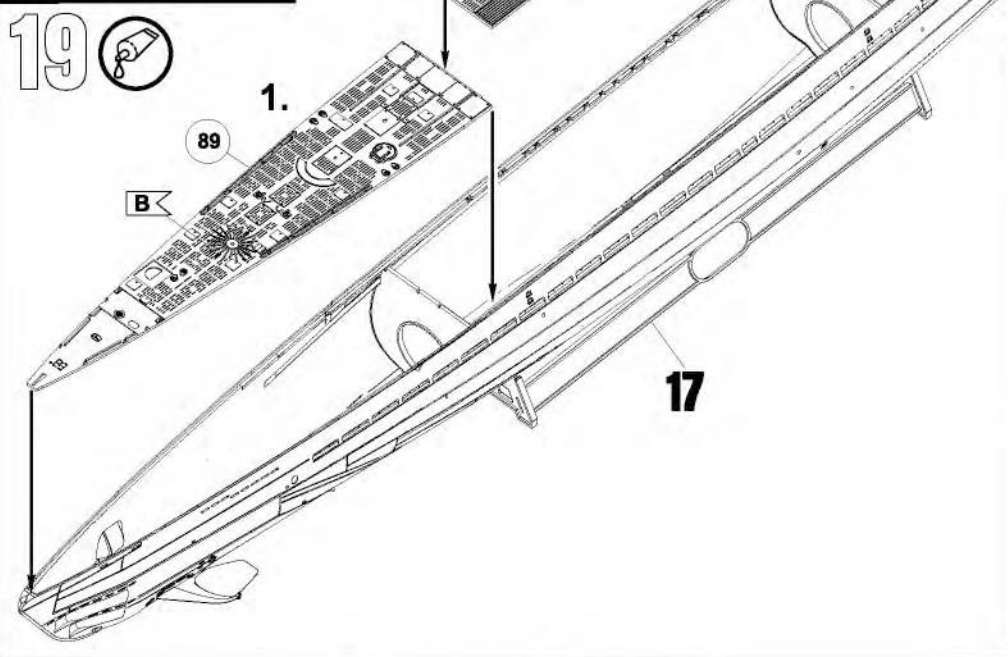
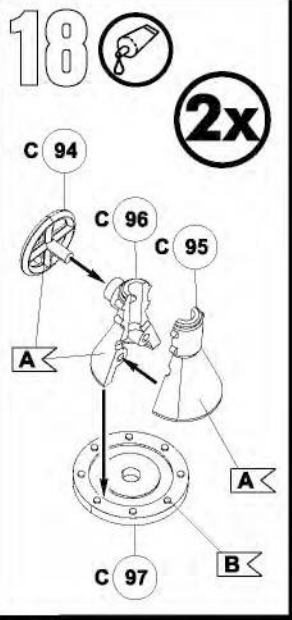

24 

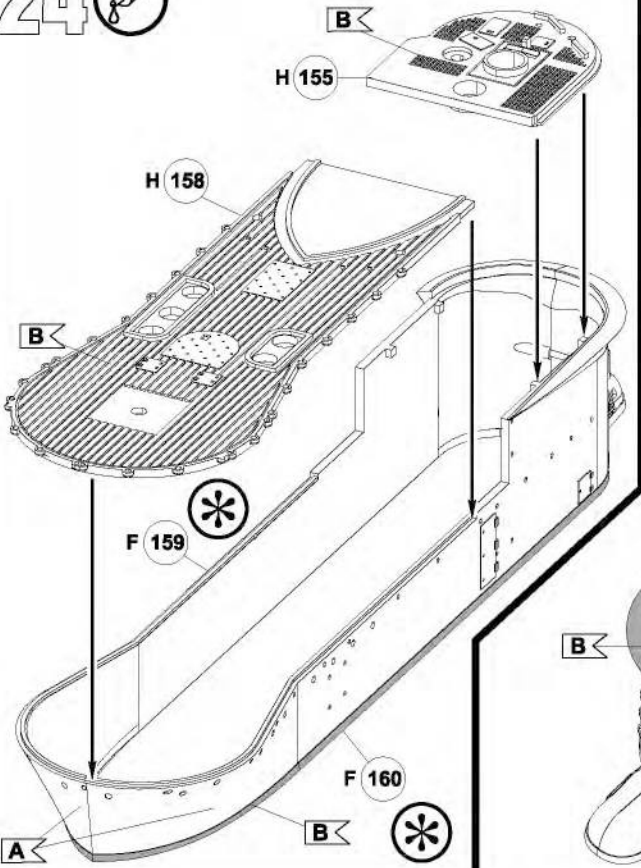

25 

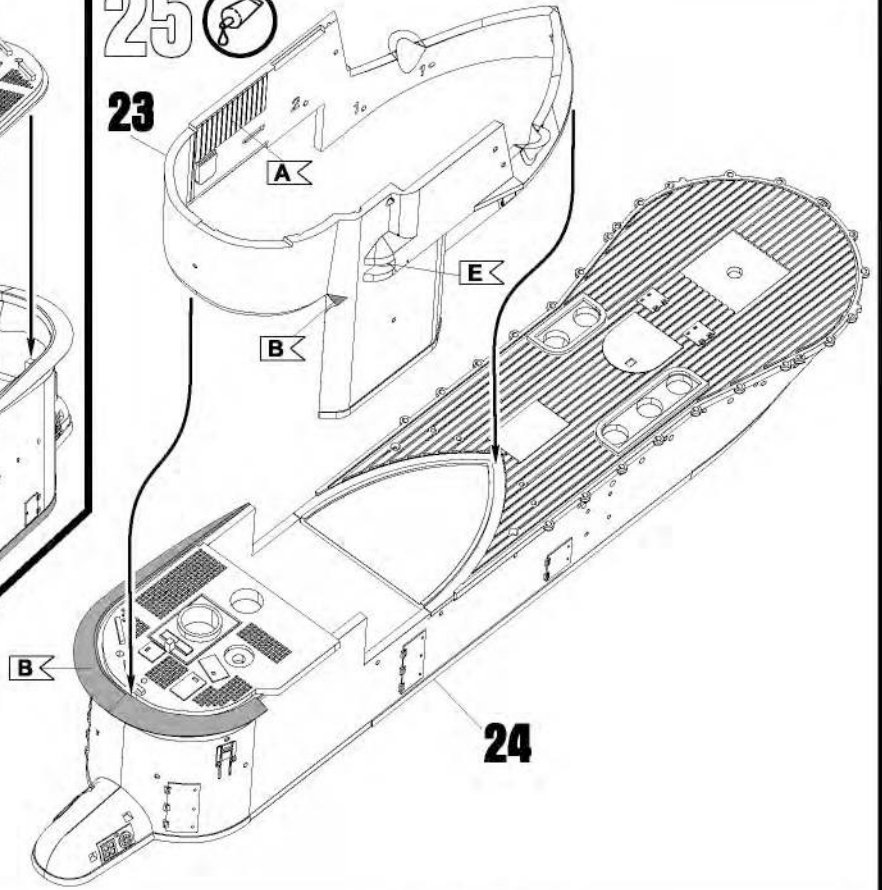

26 

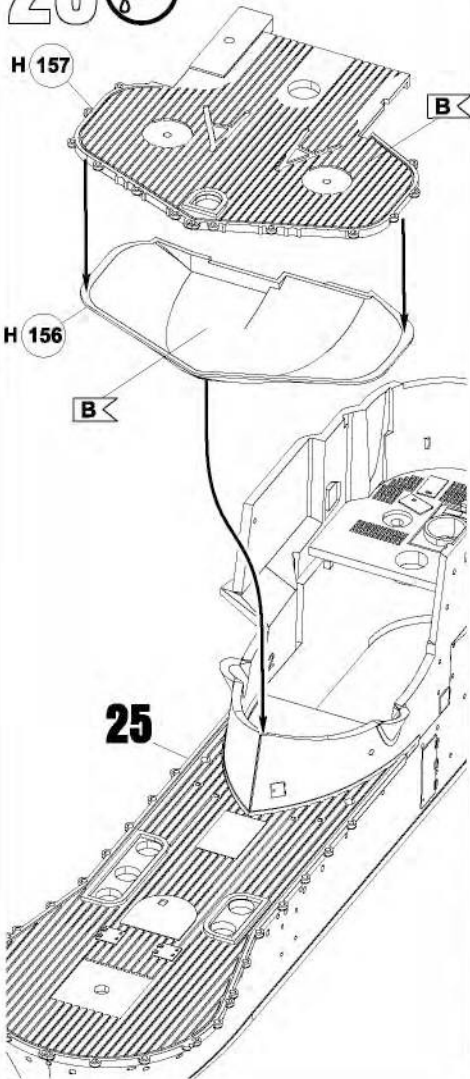

27 

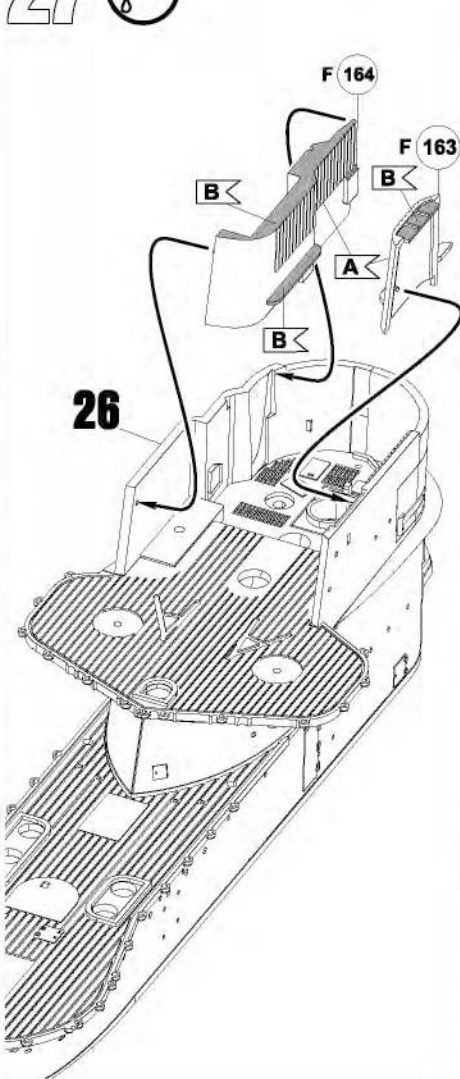

28 

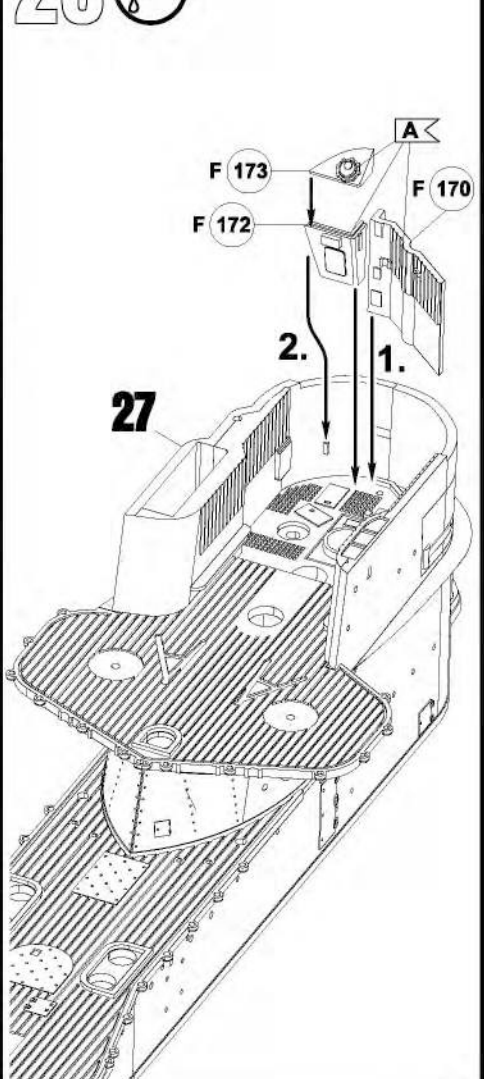

29 

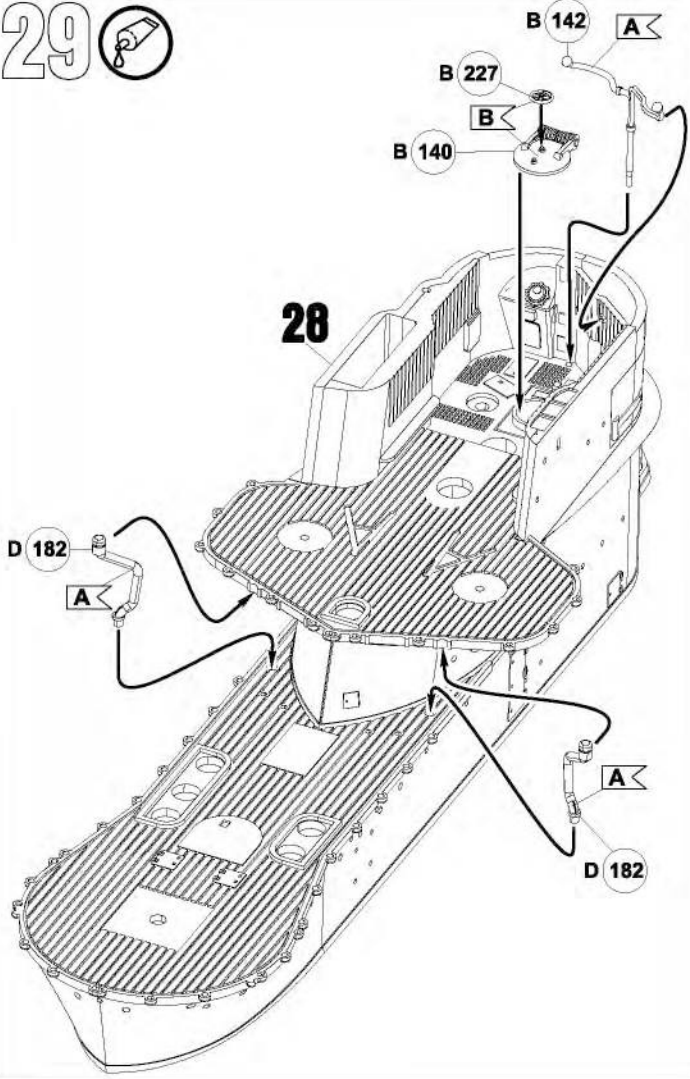

30 

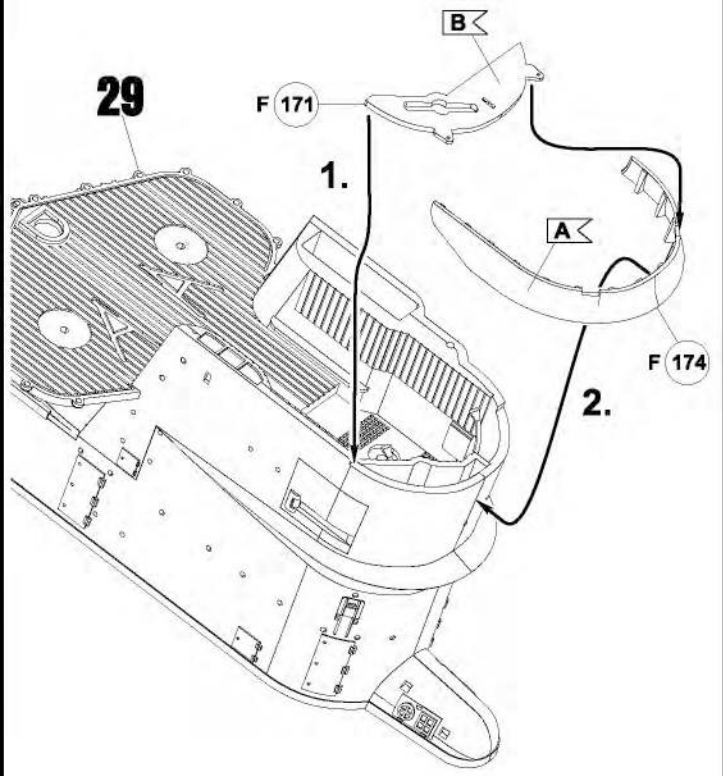

31 

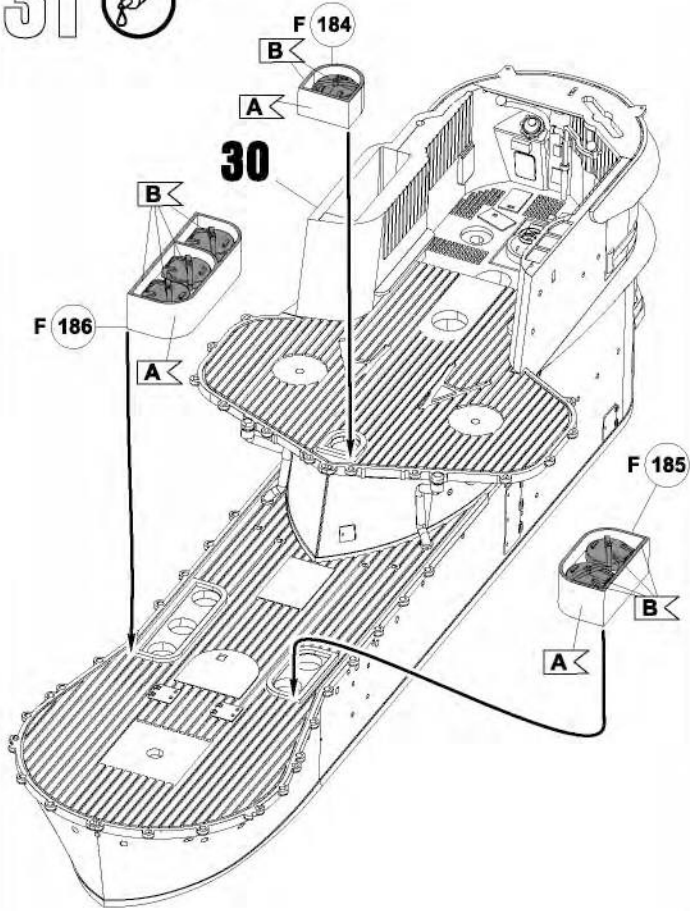

32 

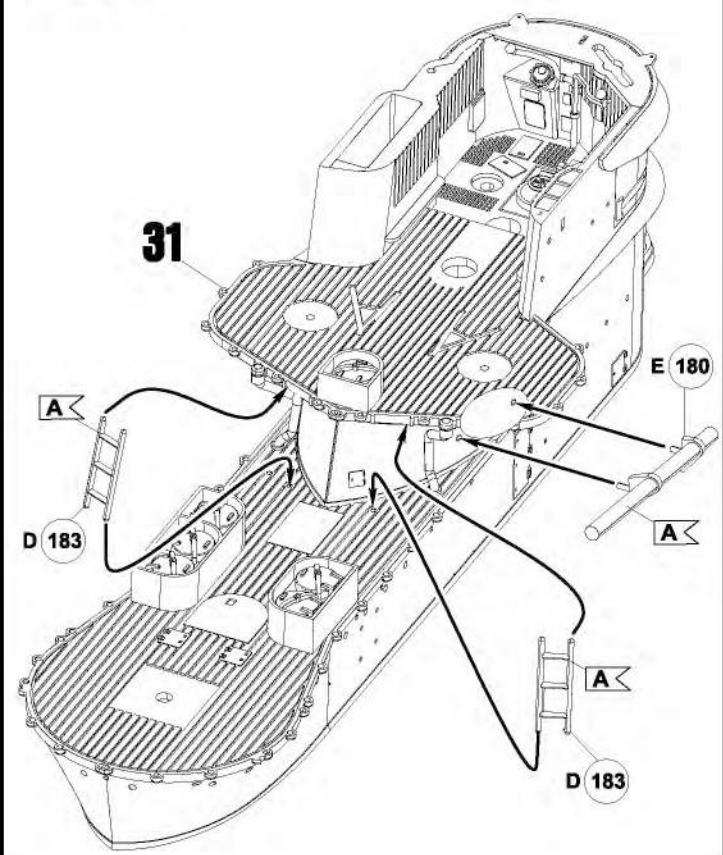

33 

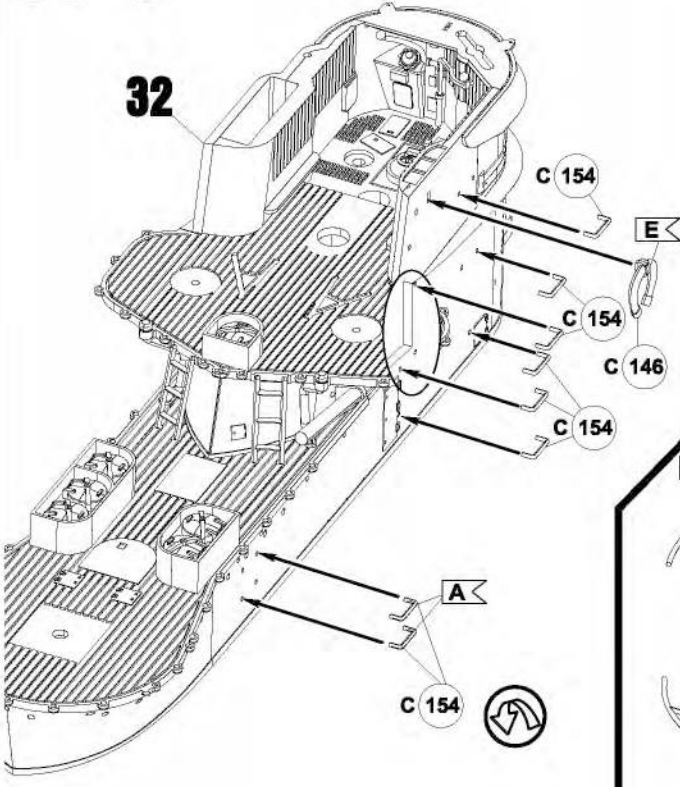

34 

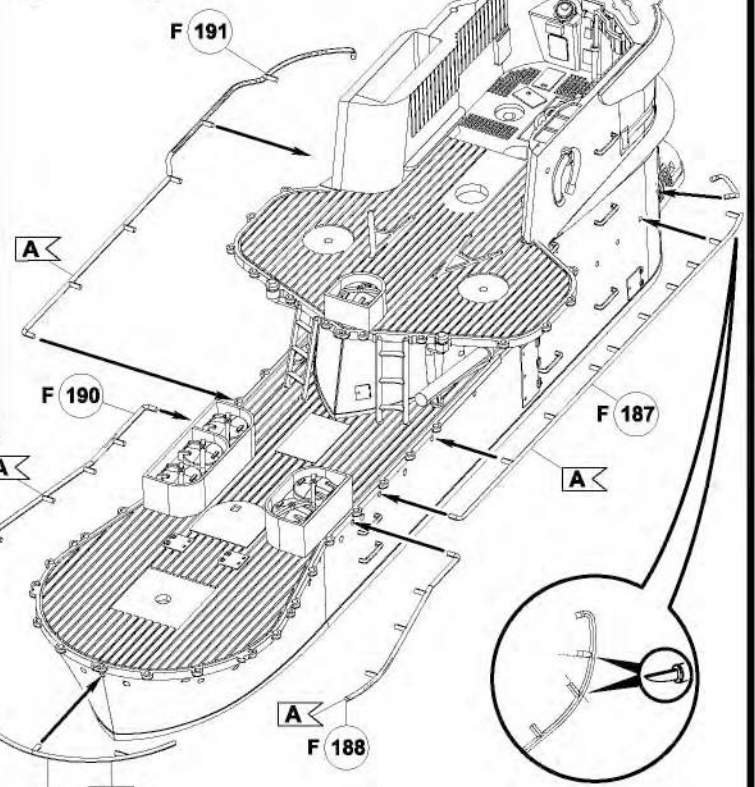

35 

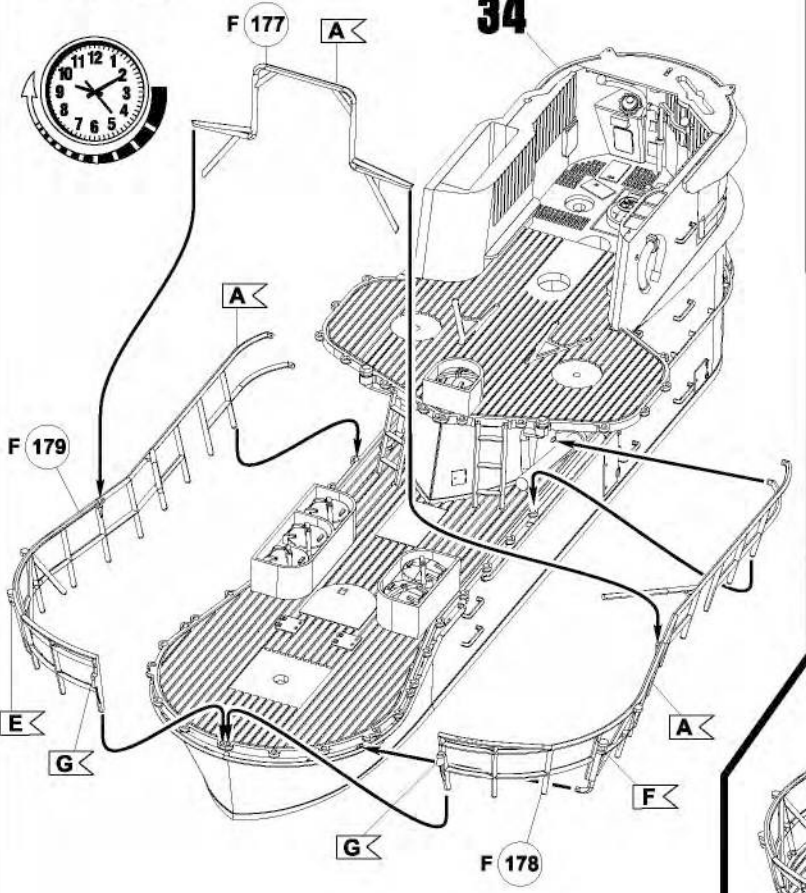

36 

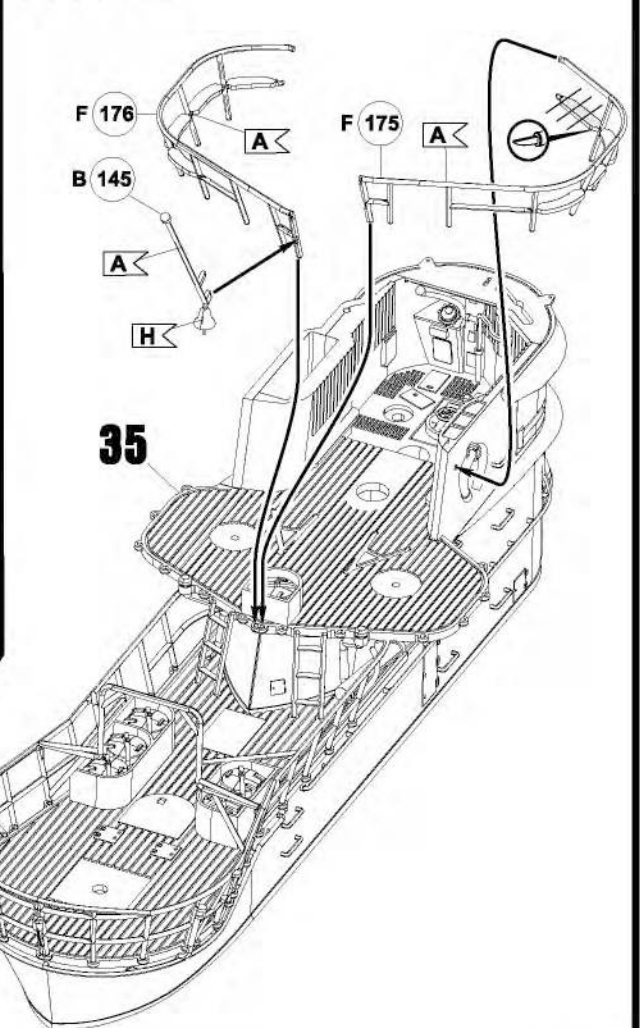

37

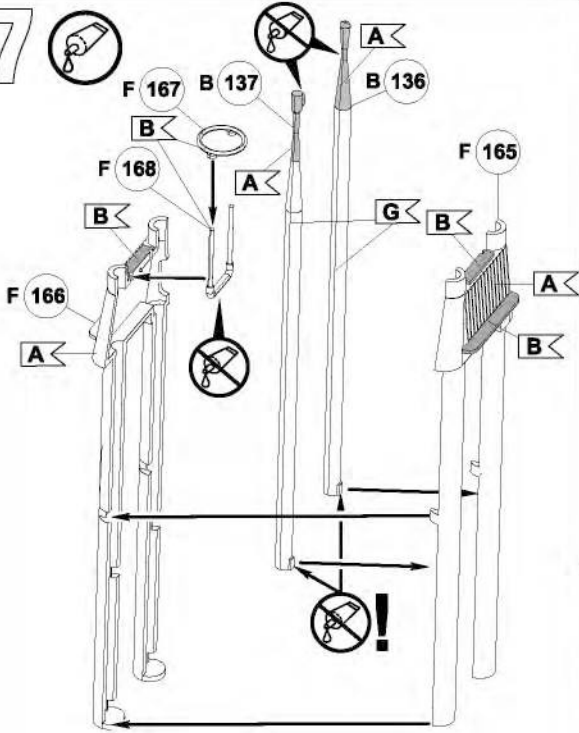

38

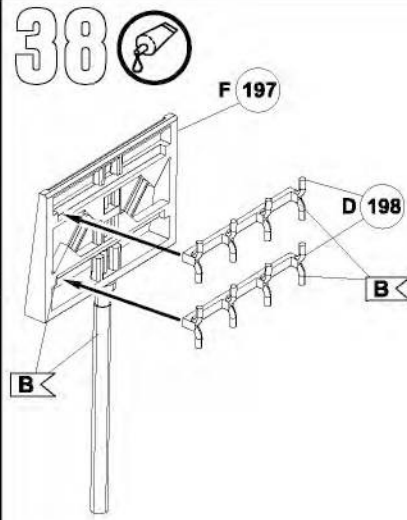

39

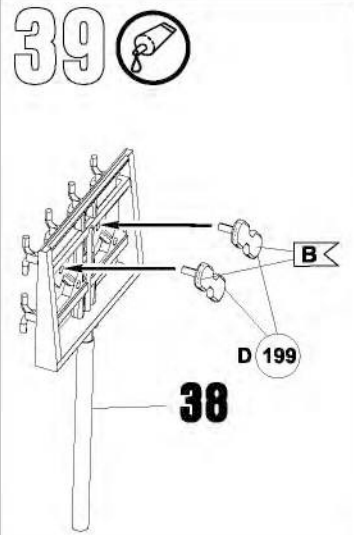

40

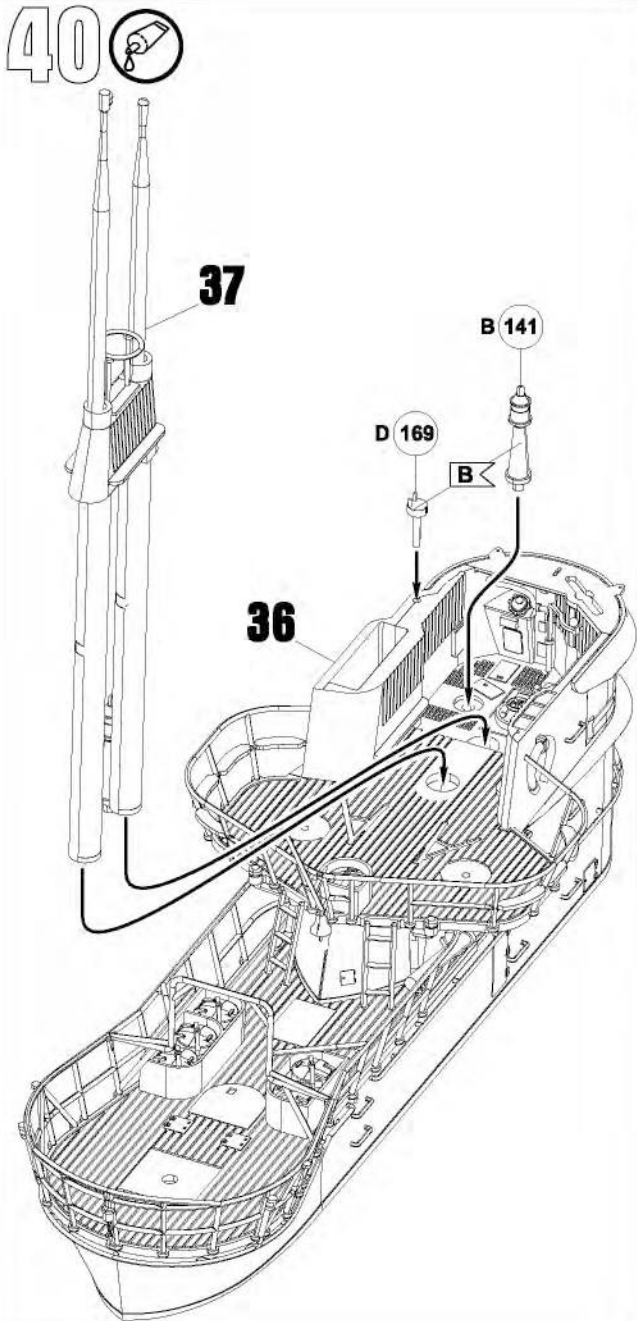

41

2x

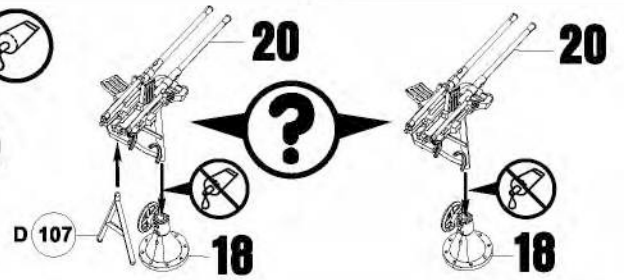

42

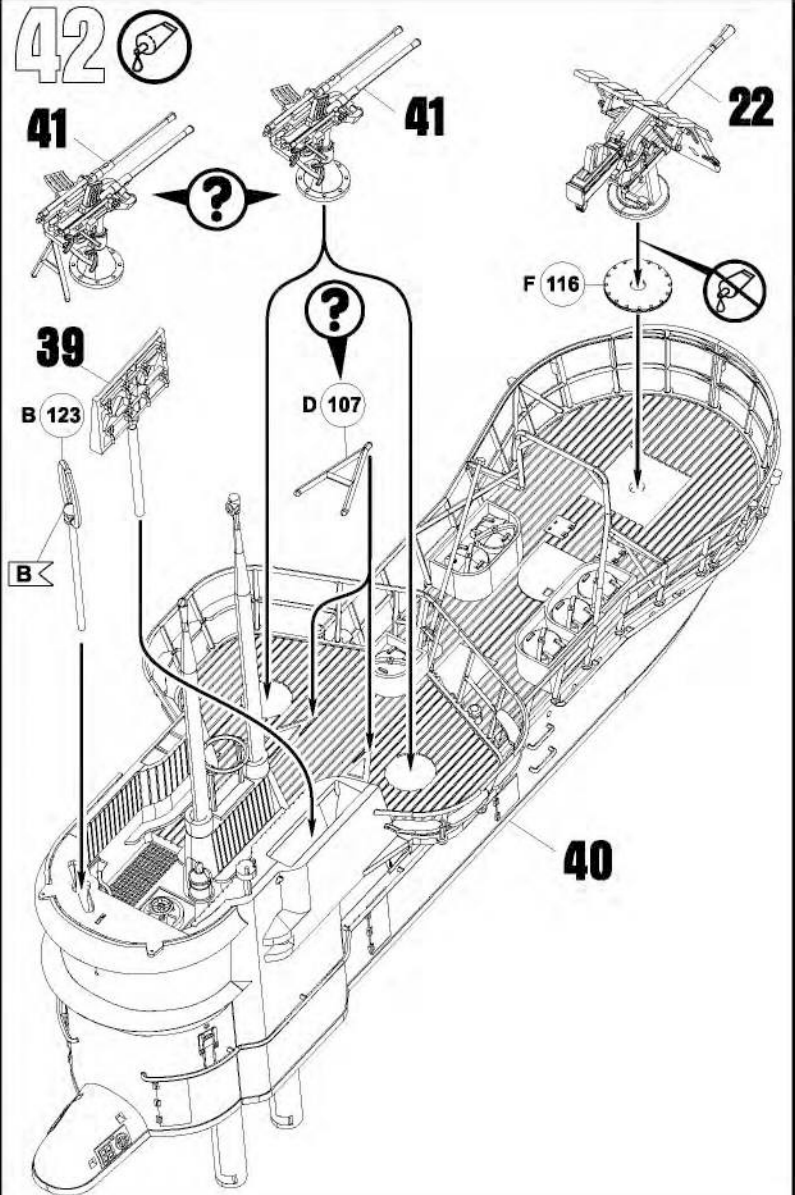

43 



42

19

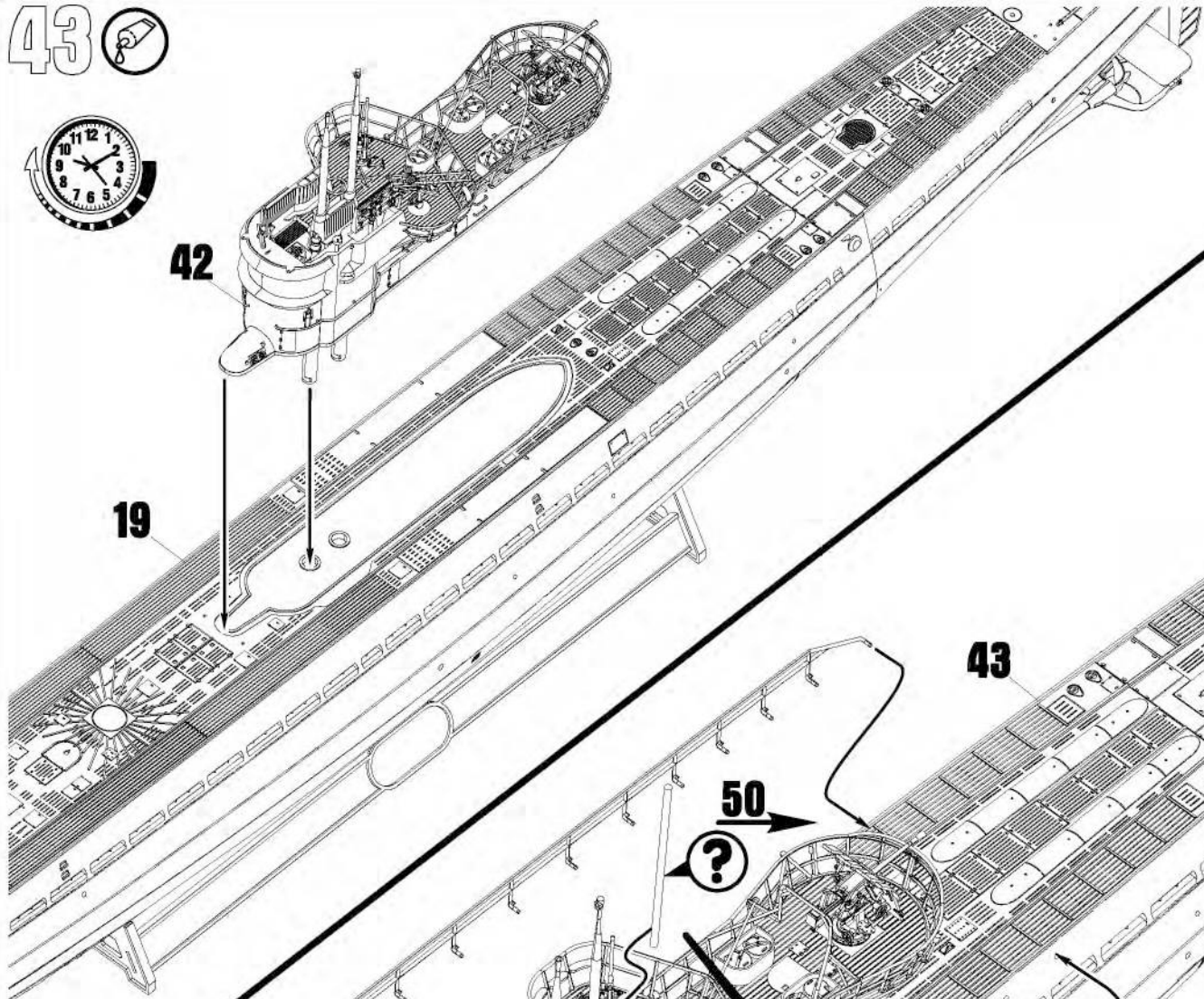

43

50



44 

E 78

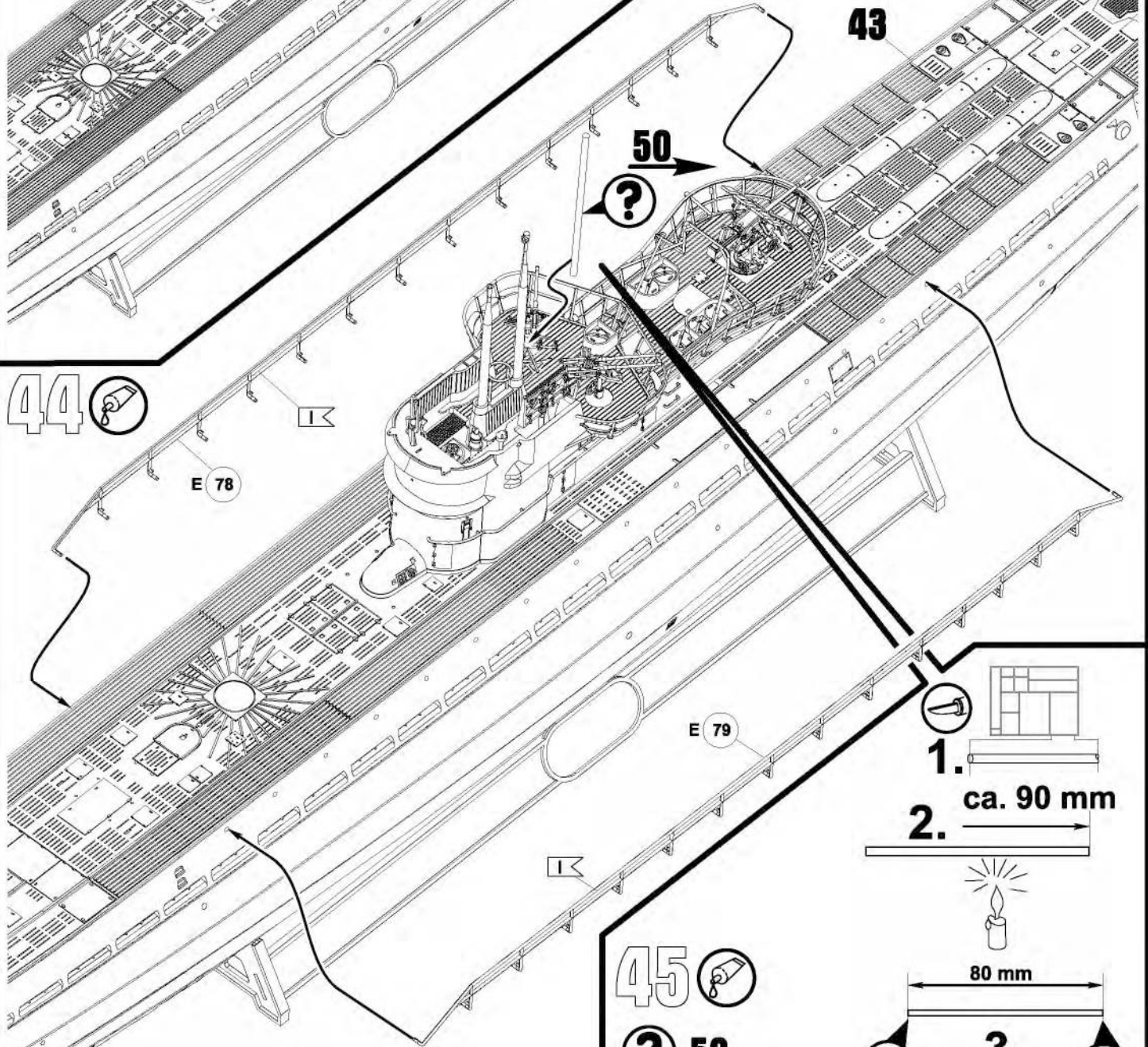

E 79



1.

2. ca. 90 mm



80 mm

3.

45 

? 50 



46

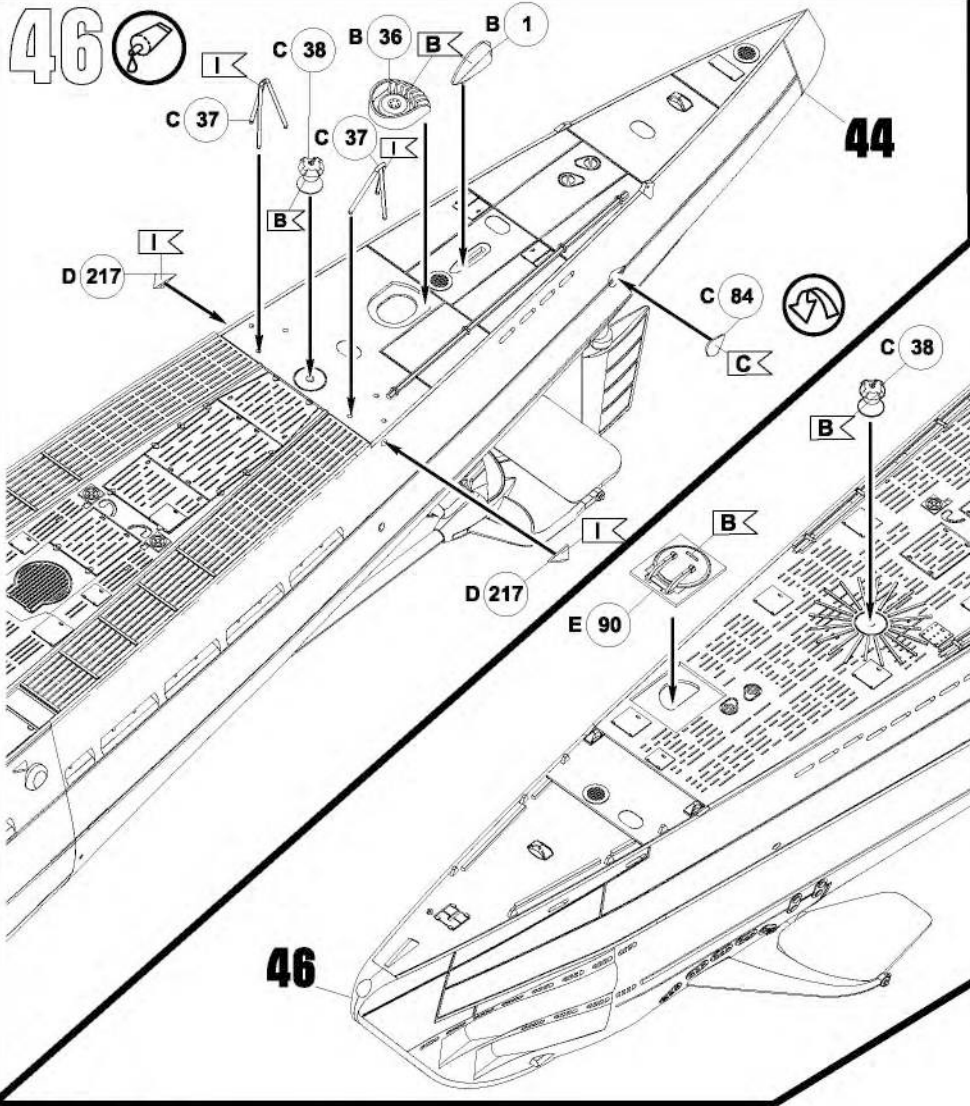

47

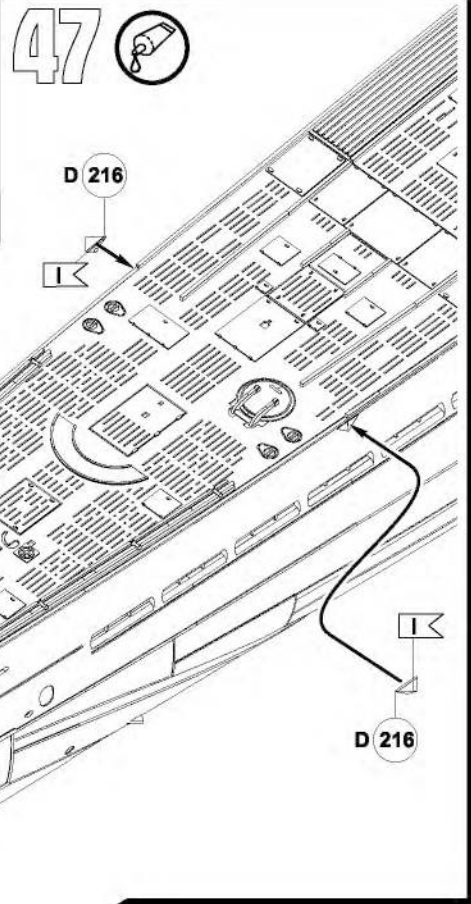

46

48

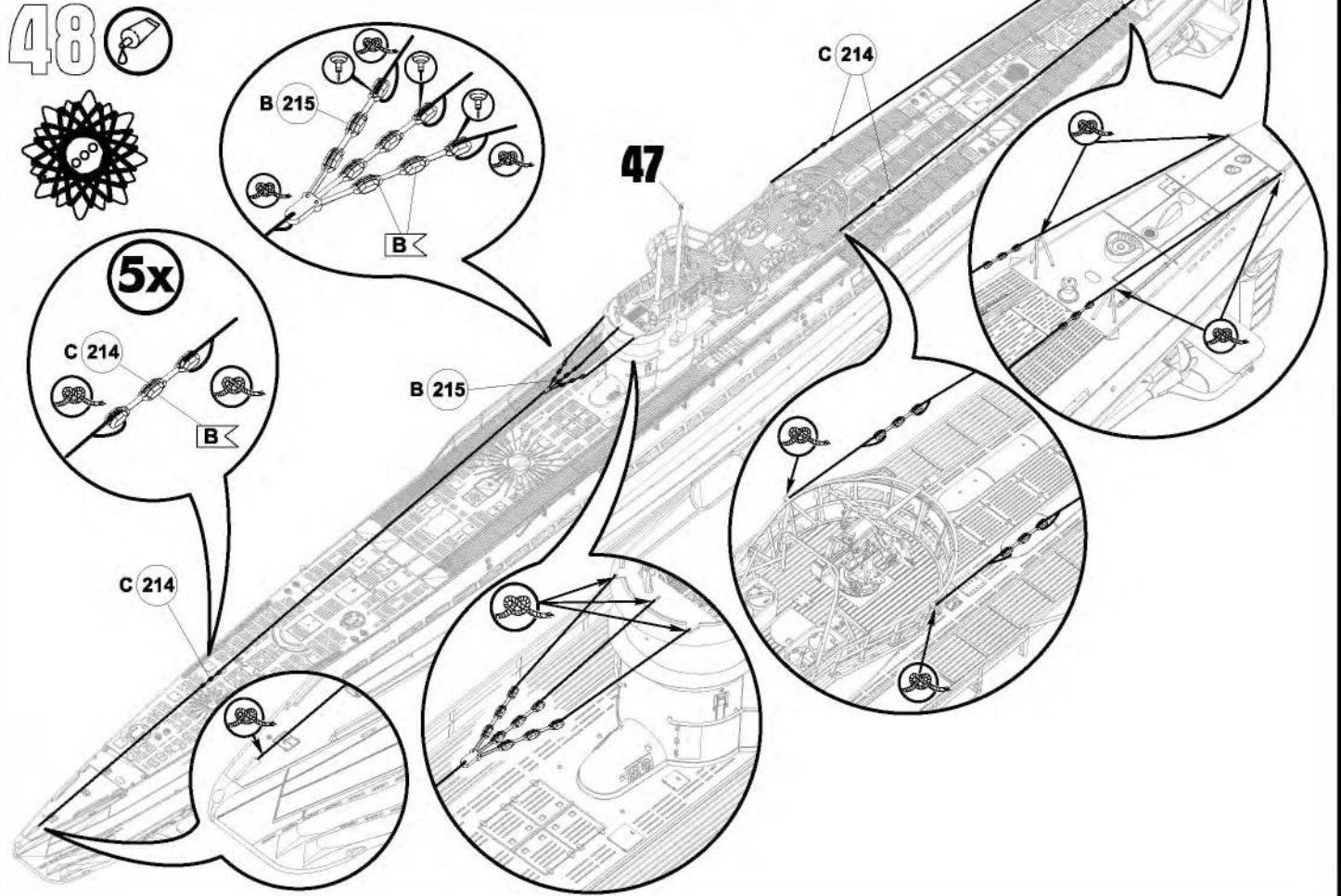

47

49 ? ?

Submarine Type IX C, U 505, 2th U-Flottilla, Atlantic Ocean, March, 16th – June, 4th, 1944

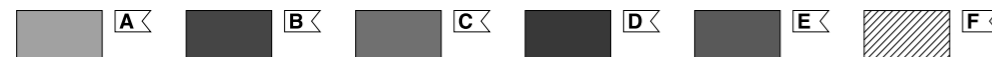
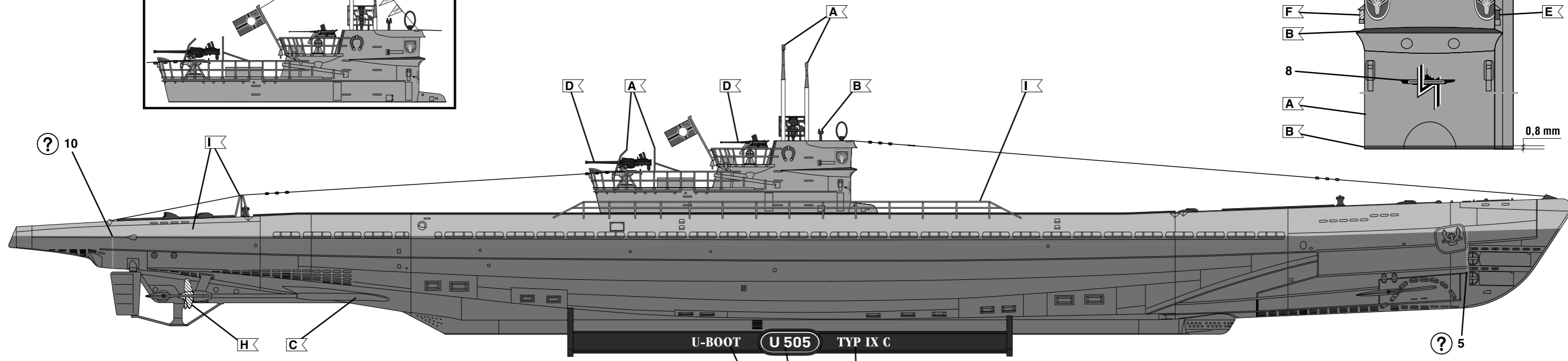
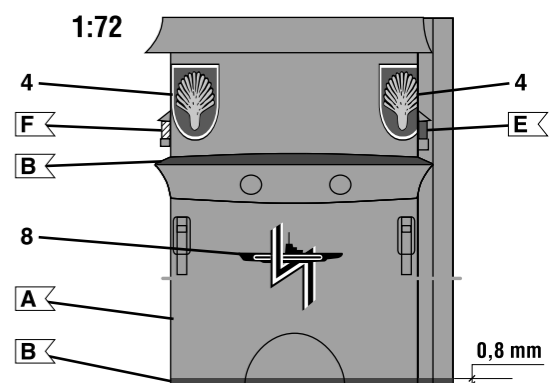
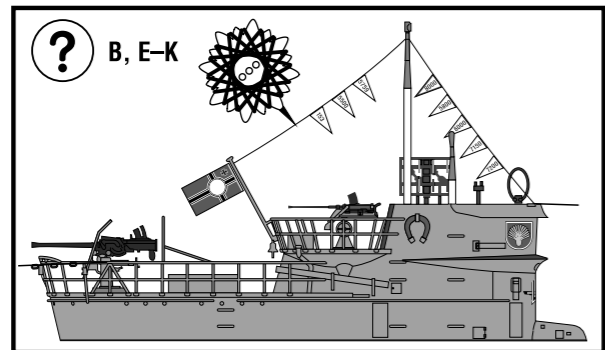
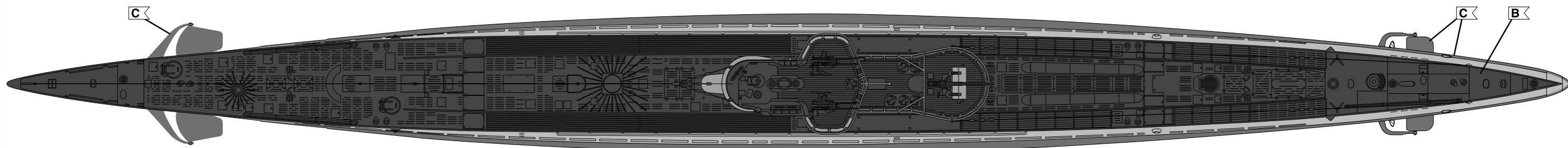
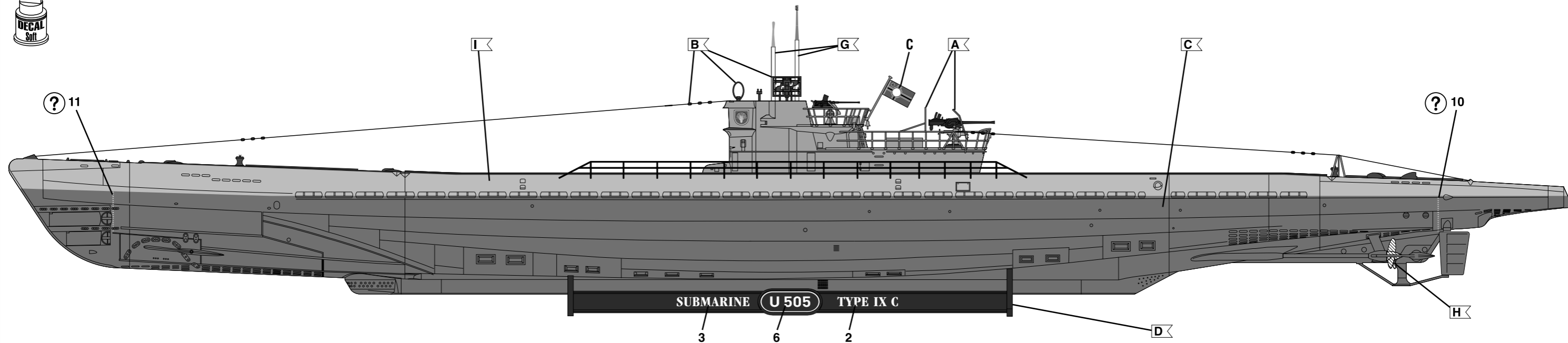

Submarine Type IX C, U 505, captured by the US Navy, Atlantic Ocean, June, 4th – June, 20th, 1944

