



1:72 Boeing Fortress Mk.III™

A08018 SCALE MODEL CONSTRUCTION KIT | Wingspan: 438mm Fuselage Length: 320mm | Two Decal Schemes Included

GB

Although better known as a daylight heavy bomber in USAAF service, the Boeing B17 (called Boeing Fortress Mk.III in RAF service) also served in a far more secretive role during the latter stages of the Second World War. In the dead of night, B17s were flown by the RAF's secret 100 Group, operated by 223 and 214 Squadrons. The job of these nocturnal Boeings was to mingle with the bomber stream and using an electronic warfare system known as 'Airborne Cigar' (ABC) attempt to jam German ground controller broadcasts so that the Luftwaffe night fighters could not find and intercept the bombers. They would even, using German speakers on board, pretend to be ground controllers themselves and try to steer the German night fighters away from the bombers. This was a hazardous and secretive job, the aircraft themselves were seldom photographed and the jobs the crews did were not widely known. Many of the aircraft featured a /G suffix after their serial number, denoting that an armed guard was necessary at all times when the machine was on the ground. This early version of electronic warfare paved the way for the highly sophisticated aircraft and systems used by air forces today.

Specification

Maximum Speed: 287 mph (462km/h)

Range: 2,000 miles (3,219 km)

Wingspan: 103 ft 9 in (31.67m)

Length: 74 ft 9 in (22.83 m)

Armament: 6 x .5in (12.7mm) machine guns

Crew: 10

FR

Le Boeing B17, plus connu en tant que bombardier lourd de jour au sein de la USAAF, était appelé Boeing Fortress en service avec la RAF où il jouait un rôle beaucoup plus secret pendant les dernières étapes de la Deuxième Guerre mondiale. Au beau milieu de la nuit, les escadrilles 223 et 214 du Groupe 100 secret de la RAF utilisaient des B17 pour se joindre au flot des bombardiers. Ils profitaient du système de guerre électronique connu sous le nom de « Cigare aéroporté ABC » afin d'essayer de brouiller les émissions des contrôleurs allemands au sol. Ainsi les chasseurs de la Luftwaffe ne pouvaient ni repérer ni intercepter les bombardiers. Les B17 utilisaient à bord des germanophones qui faisaient semblant d'être des contrôleurs pour diriger les chasseurs de nuit allemands loin des bombardiers. Opération dangereuse et secrète, il y avait peu de photos des appareils et peu de connaissance des activités des équipages. Beaucoup des avions disposaient d'un suffixe /G après le numéro de série, indiquant qu'il fallait toujours un garde armé quand l'avion se trouvait au sol. Cette première version de la guerre électronique ouvrit la voie aux avions et systèmes très sophistiqués utilisés de nos jours par les forces aériennes.

Spécification:

Vitesse maximale: 462 km/h

Autonomie: 3.219 km

Envergure: 31,67 m

Longueur: 22,83 m

Armement: 6 mitrailleuses de 12,7 mm

Equipage: 10

DE

Obwohl vor allem als schwerer Bomber für Tageslicht-Bombenangriffe im Dienst der USAAF bekannt, wurde die Boeing B17 (als Boeing Fortress Mk.III im Dienst der RAF) in der Endphase des Zweiten Weltkriegs auch in einer streng geheim gehaltenen Funktion eingesetzt. In finsterner Nacht wurden diese B17 nämlich von den für die RAF-Geheimgruppe 100 operierenden Geschwadern 223 und 214 geflogen. Vorgeblich waren sie zwar Teil der normalen Angriffsstaffeln, doch waren sie mit einem als „Airborne Cigar“ (ABC) bezeichneten elektronischen Abwehrsystem zur Überlagerung der Funkverbindungen deutscher Bodenstationen mit den Nachtjägern der Luftwaffe ausgerüstet. Damit sollte es diesen unmöglich gemacht werden, die angreifenden Bomber zu finden und abzufangen. In den B17 flogen sogar deutsch sprechende Funker mit, die sich in Funkmeldungen als Fluglotsen der Luftwaffe ausgaben und versuchten, die deutschen Nachtjäger von den angreifenden Bombern wegzusteuern. Das war eine äußerst gefährliche Aufgabe; die Flugzeuge selbst wurden nur selten fotografiert, und die Funktionen ihrer Besatzungen blieben weithin unbekannt. Viele dieser Maschinen trugen nach ihrer Seriennummer den zusätzlichen Buchstaben G. Das bedeutete, dass stets ein bewaffneter Wächter (auf Englisch „Guard“) auf Posten war, wenn sich die Maschine auf dem Boden befand. Diese frühe elektronische Kampfausrüstung war ein Wegbereiter für

jene technisch hochentwickelten Systeme, wie sie heute von modernen Luftstreitkräften eingesetzt werden.

Spezifikation:

Höchstgeschwindigkeit: 462 km/h

Reichweite: 3.219 km

Spannweite: 31,67 m

Länge: 22,83 m

Bewaffnung: Sechs 12,7 mm MG;

Besatzung: 10

Airfix would like to express their thanks to IWM Duxford, The Smithsonian, Lynn Ritger, Jon Brawner, Karl Hauffe, Roy Sutherland and Jan Zdiarský for their help with the development of this product.



B-17 Flying Fortress™

Produced under License. Boeing, B-17 Flying Fortress, the distinctive Boeing logos, product markings and trade dress are trademarks of The Boeing Company.

HORNBY HOBBIES

FOR BEST RESULTS:

Surfaces to be painted should be clean — before parts are removed from the sprue, wash in warm, soapy water, rinse and dry thoroughly. Stir paints thoroughly before use.

PLEASE NOTE:

Some parts in the kit may not be required to build the model specified.



ES El Boeing B-17 'Fortaleza Volante' puede presumir de un magnífico legado, como arma estratégica y como símbolo duradero del poder estadounidense durante la Segunda Guerra Mundial. El B-17, diseñado como gran bombardero con varios motores y con un fuerte armamento defensivo, se introdujo en 1938. Tras sus primeras misiones de combate con la RAF en 1941 en bombardeos sobre Francia, su escaso rendimiento sugirió que sería preciso mejorar las defensas y aumentar la precisión en el bombardeo para poder considerar seriamente el uso del B-17 como bombardero pesado. Variantes posteriores como la B-17G demostraron una mayor efectividad, y con el tiempo se convirtió en una potente arma estratégica, capaz de llevar a cabo ataques a gran distancia y desde elevada altitud. A pesar de su fuerte armamento defensivo, los B-17 siguieron sufriendo a manos de los cazas enemigos y las pérdidas solo llegarían a ser aceptables con la introducción de cazas escolta de gran autonomía. En el Pacífico, el B-17 destacó como aparato de gran resistencia, capaz de resistir los implacables ataques japoneses desde Pearl Harbour hasta las Filipinas. En Europa, integrado en la Octava Fuerza Aérea, el B-17 también tuvo un papel crucial en la 'Ofensiva combinada de bombardeo', una operación estratégica conjunta USAAF-RAF contra objetivos industriales y de la Luftwaffe sobre toda la geografía alemana entre 1943 y 1945. El B-17 fue

responsable de casi 700 000 de los 1,5 millones de toneladas de bombas lanzadas sobre objetivos alemanes por aparatos de la USAAF.

Especificación:

Velocidad máxima: 462 km/h

Autonomía: 3219 km

Envergadura: 31,67 m

Longitud: 22,83 m

Armamento: 6 ametralladoras de 12,7 mm

Tripulantes: 10

SE Boeing B-17, eller "Flying Fortress", har ett ärorikt förflutet både som ett strategiskt vapen och en bestående symbol för den amerikanska flyginsatsen under andra världskriget. B-17, som introducerades 1938, utformades som ett stort flermotorigt bomplan med omfattande defensiv beväpning. Första gången det sattes in i strid var 1941 då RAF genomförde bombträder i Frankrike. Dess bristande framgångar visade dock på att förbättrade defensiva funktioner och mer precisionsmässig bombing krävdes om B-17 någonsin skulle bli tillförlitligt som tungt bomplan. Senare varianter som B-17G visade sig vara mer effektiva och utvecklades gradvis till användbara strategiska vapen som kunde genomföra uppdrag på hög höjd och med lång räckvidd. Trots den tunga defensiva beväpningen led B-17-planen nya nederlag mot fiendens jaktplan, och det var endast introduktionen av eskorterande jaktplan med lång räckvidd som sänkte förlustsiffrorna. I stillahavsområdet, från Pearl Harbour till Filipinerna, utgjorde B-17 en slitstark resurs som gjorde väl ifrån sig under de japanska attackerna. Som en del av Eighth Air Force i Europa spelade B-17 även en viktig roll under "Combined Bomber Offensive", en strategisk bombkampanj från USAAF och RAF mot

industriella och Luftwaffe-mål i Tyskland 1943-1945. Av de 1,5 miljoner ton bomber som släpptes över tyska mål från USAAF-plan svarade B-17 för nästan 700 000.

Spekifikation:

Maximal hastighet: 462 km/h

Räckvidd: 3219 km

Spännvidd: 31,67 m

Längd: 22,83 m

Bestyckning: 12,7 mm kulsprutor

Besättning: 10

GB Study drawings and practise assembly before cementing parts together. Carefully scrape paint from cementing surfaces. All parts are numbered. Paint small parts before assembly. To apply decals cut sheet as required, dip in warm water for a few seconds, slide off backing into position shown. Use in conjunction with box artwork. Not appropriate for children under 36 months of age, due to the presence of small detachable parts.

FR Étudier attentivement les dessins et simuler l'assemblage avant de coller les pièces. Gratter soigneusement toute peinture sur les surfaces à coller. Toutes les pièces sont numérotées. Peindre les petites pièces avant l'assemblage. Pour coller les décalcomanies, découper le motif, le plonger quelques secondes dans de l'eau chaude puis le poser à l'endroit indiqué en décollant le support papier. Utiliser conjointement avec les illustrations sur la boîte. Ne convient pas aux enfants de moins de 36 mois - présence de petits éléments détachables.

DE Vor dem Zusammenkleben der Teile die Zeichnungen sorgfältig ansehen und die zu verklebenden Teile zur Vermeidung möglicher Fehler versuchsweise zusammenfügen. Dann an den Klebeflächen vorhandene Farbbeschriftung vor dem Zusammenkleben vorsichtig abkratzen. Alle Bestandteile sind mit Nummern versehen. Kleine Teile vor dem Zusammenbau bemalen. Abziehbilder wie gewünscht ausschneiden. Vor dem Anbringen einige Sekunden in warmes Wasser tauchen und dann vom Trägerpapier in ihre vorgesehene Position schieben. Dabei die Abbildungen auf der Schachtel beachten. Nicht für Kinder unter 36 Monaten geeignet, da abnehmbare bzw. lose angebrachte Kleinteile enthalten sind.

ES Estudiar los dibujos y practicar el montaje antes de pegar las piezas. Raspar cuidadosamente la pintura en las superficies de contacto antes de pegar las piezas. Todas las piezas están numeradas. Es conveniente pintar las piezas pequeñas antes de su montaje. Para aplicar las calcomanías, cortarlas de la hoja, sumergirlas en agua tibia durante unos segundos y deslizarlas a la posición indicada. Utilizar en conjunción con la ilustración de la caja. No es adecuado para niños menores de 36 meses, ya que contiene piezas pequeñas que podrían soltarse.

Assembly Instructions

IT Studiare i disegni ed esercitarsi a montare i vari pezzi prima di fissarli con la colla. Raschiare con cura le tracce di vernice dalle superfici da incollare. Tutti i pezzi sono numerati. Verniciare i pezzi di piccole dimensioni prima di montarli. Per applicare le decalcomanie, ritagliare il foglio nel modo richiesto, immergere in acqua calda per alcuni secondi, quindi staccare la decalcomania dalla carta di supporto e posizionarla nel punto desiderato. Usare le decalcomanie come indicato nell'illustrazione riportata sulla confezione. Non adatto a bambini di età inferiore a 36 mesi per la presenza di componenti di piccole dimensioni che potrebbero staccarsi.

DK Studér tegningerne nøje og forsøg at sætte delene sammen, inden de klæbes sammen. Skrab forsigtigt malingen af de overflader, der skal klæbes sammen. Alle dele er nummererede. Små dele skal males, før de monteres. Overføringsbillederne påføres ved at klippe dem ud af arket, som påkrævet, dypp dem i varmt vand i nogle få sekunder, hvorefter underlaget gøres af i de viste positioner. Påføres ifølge illustrationerne på æsken. Ikke egnet til børn under 3 år på grund af tistedeværelse af små aftagelige dele.

NL Tekeningen bestuderen en delen in elkaar zetten alvorens deze te lijmen. Lak voorzichtig van lijmvlakken afschrapen. Alle delen zijn genummerd. Kleine delen vóór montage verven. Voor aanbrengen van stickers, gewenste stickers uit het vel knippen, een paar seconden in warm water dompelen en dan van het schutblad af op afgebeelde plaats schuiven. Hierbij afbeelding op doos raadplegen. Niet geschikt voor kinderen onder 3 jaar, omdat kleine deeltjes gemakkelijk kunnen losraken.

SE Studera bilderna noggrant och sätt ihop delarna innan du limmar ihop dem. Skrapa försiktigt bort färg från limmade delar. Alla delarna är numrerade. Måla smådelarna före inopsättning. Sätt fast dekalerna genom att klippa arket, doppa i varmt vatten några sekunder och låta baksidan glida på plats som bilden visar. Använd enligt bildanvisningarna på kartongen. Rekommenderas ej för barn under 3 år. Innehåller löstlagbara smådelar.

FI Tutustu piirroksiin ja harjoittele kokoamista, ennen kuin liimaat osat yhteen. Raaputa maali varovasti pois liimattavilta pinnolta. Kaikki osat on numeroitu. Maalaa pienet osat ennen kokoamista. Siirtokuvien kiinnittämiseksi leikkaa ne arkista tarpeen mukaan. Kasta kuva lämpimään veteen muutaman sekunnin ajaksi, anna takapuolen liukua kovalle osoitettuun kohtaan. Käytetään yhdessä laatikon kuvituksen kanssa. Ei suositella alle kolmivuotiaille lapsille. Paljon irrotettavia pikkuosia.

PT Estudar atentamente os desenhos e experimentar a montagem. Raspar cuidadosamente as superfícies de modo a eliminar pintura antes de colar. Todas as peças estão numeradas. Pintar as pequenas peças antes de colar. Para aplicar as decalcomanias, cortar as folhas e mergulhar em água morna por alguns segundos, depois deslizar e aplicar no respectivo lugar, como indicado nas ilustrações na caixa. Não convém a uma criança de menos de 36 meses devido à presença de pequenos elementos destacáveis.

PL Przed przystąpieniem do sklejania przestuduj uważnie rysunki i przećwicz składanie części. Ostrożnie zeskrob ze sklejaných powierzchni farbę. Wszystkie części są ponumerowane. Drobne części pomaluj przed ich złożeniem. Celem przeniesienia kalkomanii wytnij ją z arkusza, zanurz na kilka sekund w letniej wodzie i zsuń z podłoża na wymagane miejsce. Używaj w połączeniu ze wzorami na pudełku. W związku z obecnością wielu drobnych, rozbielanych części, nieodpowiednie dla dzieci poniżej 3 lat.

EL Μελετήστε προσεκτικά τα σχέδια και συναρμολογήστε για πρώτη φορά τα κομμάτια χωρίς να τα συγκολλήσετε. Αφαιρέστε επιμελώς την πλαστική βαφή από τις επιφάνειες τις οποίες θα συγκολλήσετε. Όλα τα κομμάτια είναι αριθμημένα. Χρωματίστε τα μικρά κομμάτια πριν από τη συναρμολόγηση. Για να κολλήσετε τις χαλκομανίες, κόψτε γύρω από το σχέδιο όπως απαιτείται, βυθίστε το μερικά δευτερόλεπτα σε χλιαρό νερό και μετά τοποθετήστε το στη θέση που υποδεικνύεται, αφαιρώντας τη μεμβράνη που το καλύπτει. Λάβετε υπόψη σας ταυτόχρονα την εικονογράφηση που κολλάει. Ακατάλληλο για παιδιά ηλικίας κάτω των 36 μηνών λόγω ύπαρξης μικρών κομματιών που αποσπώνται.

ASSEMBLY ICON INSTRUCTIONS

<p>Assembly phase Phase de montage Montagephase Fase de montaje Monteringsfase Fase di montaggio Montagefase Fase de montagem Monteringsfase Monteringsfase Kokoamisvaihe Faza składowania Φάση συναρμολόγησης</p>	<p>Cement Coller Kleben Pegar Limma Incollare Lijmen Colar Klæbes Limaa Kleić Κολλήσετε Συγκολλήστε</p>	<p>Do not cement together No pas coller Nicht kleben No pegar Limma inte Non incollare Niet lijmen Nao colar Skal ikke klæbes Aia limaa Nie kleić Μη συγκολλήσετε</p>	<p>Indicates final location Indique l'emplacement final Zeigt Endposition Indica la ubicación definitiva Anger slutmonteringsplats Sede di montaggio finale Geeft uiteindelijke locatie aan Indica localização final Viser endelig placering Osoittaa lopullisen sijainnin Oznacza miejsce docelowe Υποδεικνύει τελική τοποθέτηση</p>	<p>Alternative part(s) provided Autre(s) pièce(s) fournie(s) Ersatzteil(e) mitgeliefert Se incluye(n) pieza(s) alternativa(s) Alternativ(e) delar(er) ingår Uno o più componenti alternativi forniti Alternatieve onderdelen meegeleverd Peças(s) alternativa(s) fornecida(s) Alternativ(e) del(e) medfølger Valitkoalvot osat pakkauskassa Dostigone części zamiennie Παράγονται εναλλακτικά κομμάτια</p>	<p>Repeat this operation Répéter l'opération Vorgang wiederholen Repètir la operación Upprepa åtgärden Ripetere l'operazione De verrichting herhalen Repètir a operação Manövern gentages Toista toimenpite Powtórzć ó operacj e Επανάλάβετε τη διαδικασία</p>
<p>Decals Dècalcomanies Abziehbild Calcomanias Dekaler Decalcomanie Stickers Decalcomania Billedoverføring Siirtokuvat Kalkomanie Χαλκομανίες</p>	<p>Crystal part Pièce cristal Kristallteil Pieza de cristal Kristallid Pezzo cristallo Kristallen onderdeel Peça de cristal Kryształowyk Kristalliosa Część kryształowa Κομμάτι κρυστάλλου</p>	<p>Weight Lester Beschweren Lasten Belaasta Applicare un peso Verzwaren Lastnar Påfer vægt Aseta vastapaino Obciążyc balastem Επιθέστε βάρος</p>	<p>Remove by filing Enlever avec une lime Abfeilen Eliminar con lima Ta bort genom att fila Rimouvere con la lima Verwijderen door aflijven Remove limando Fjern ved at file væk Poista viilaamalla Usun aç przy użyciu pilnika Αφαιρέστε λιμόρονοσ με λίμα</p>	<p>Drill or piece Perfor Durchbohren Perforar Bora Törönnä o bore Boren of doorboren Furar Gemborlar Poznać lub pofukajsc Wywierćć lub przedziurawić Τρυπήστε</p>	<p>Cut Découper Schneiden Cortar Skär Tagliare Snijden Cortar Skær Leikkaa Przećić Κόψτε</p>

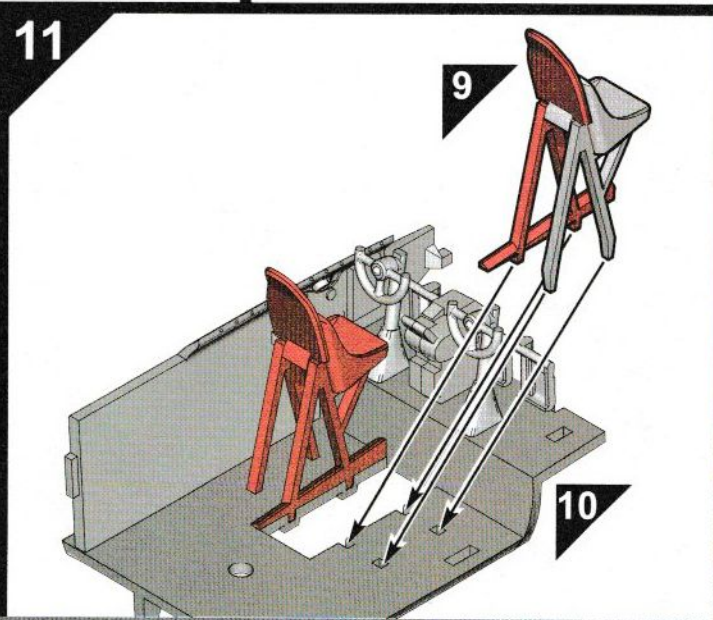
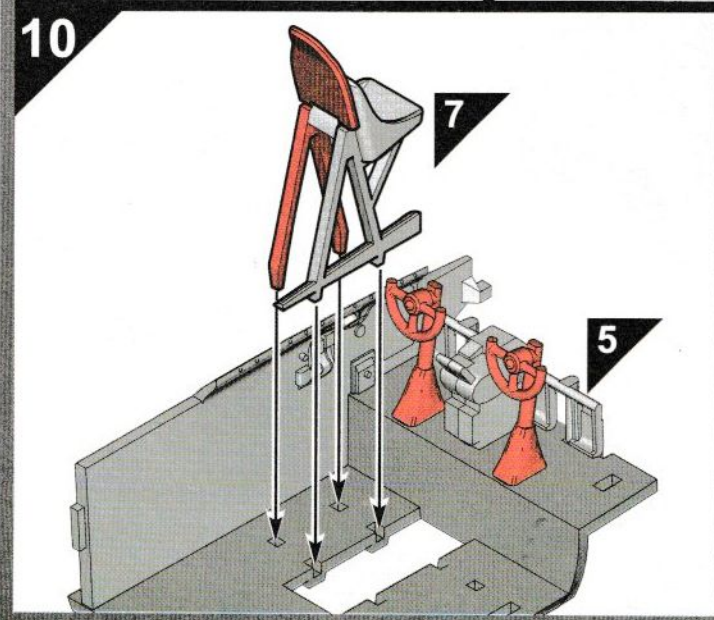
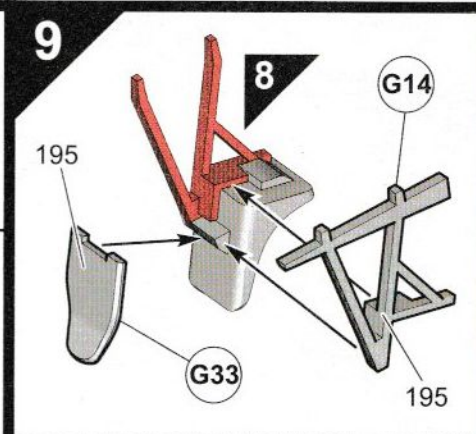
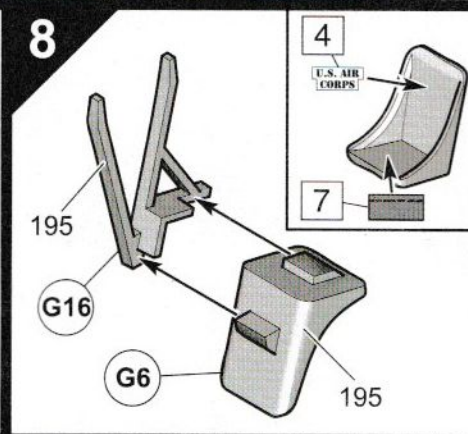
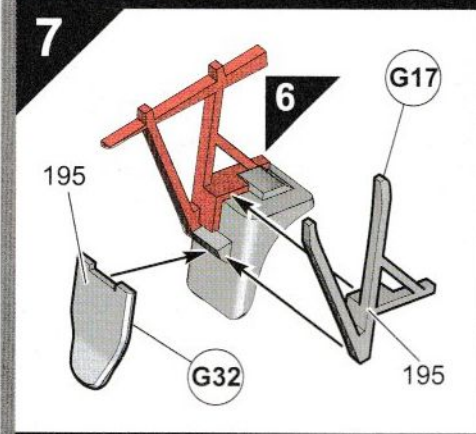
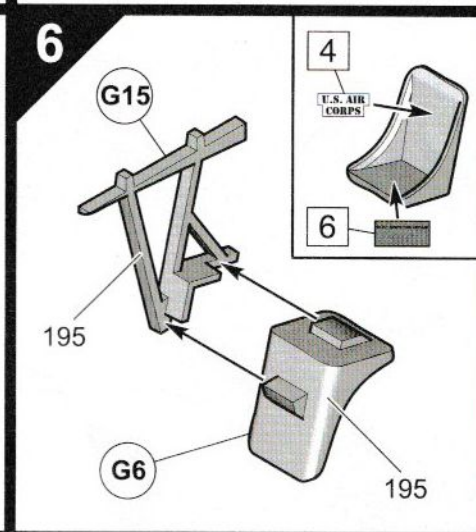
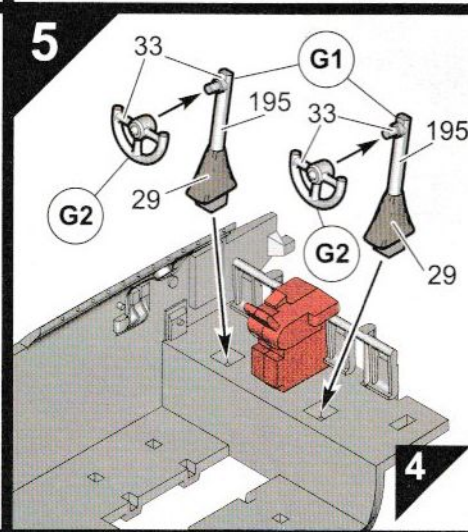
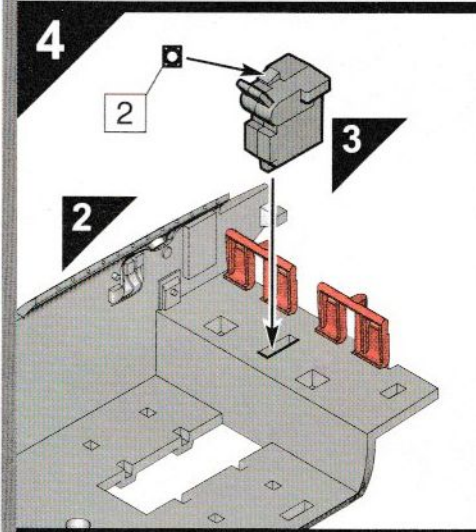
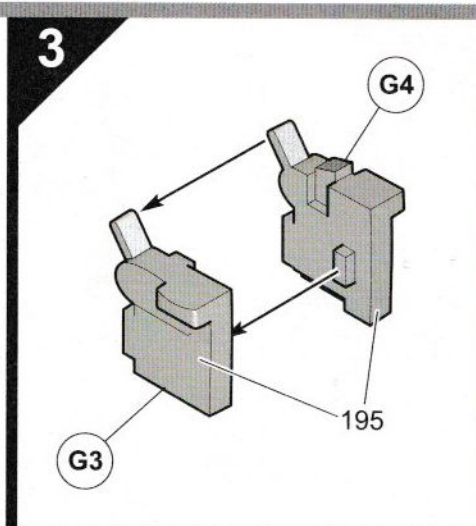
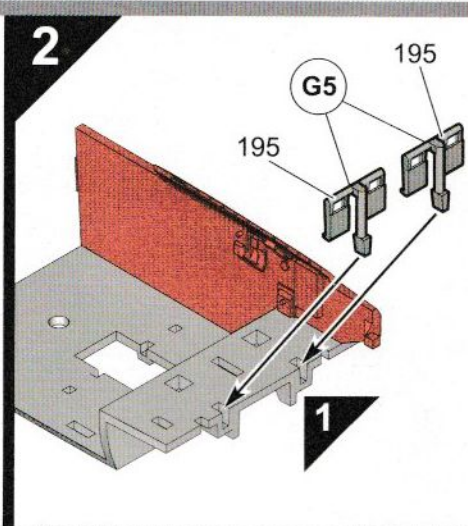
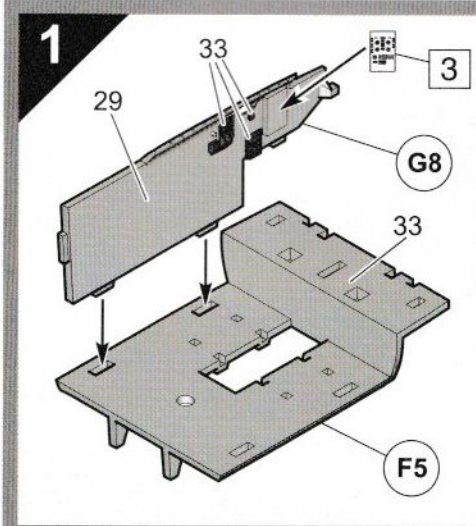

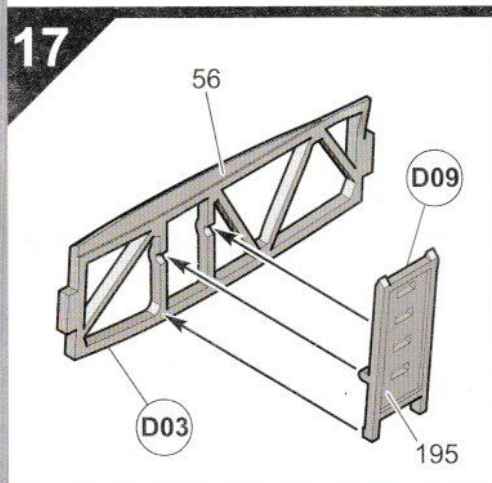
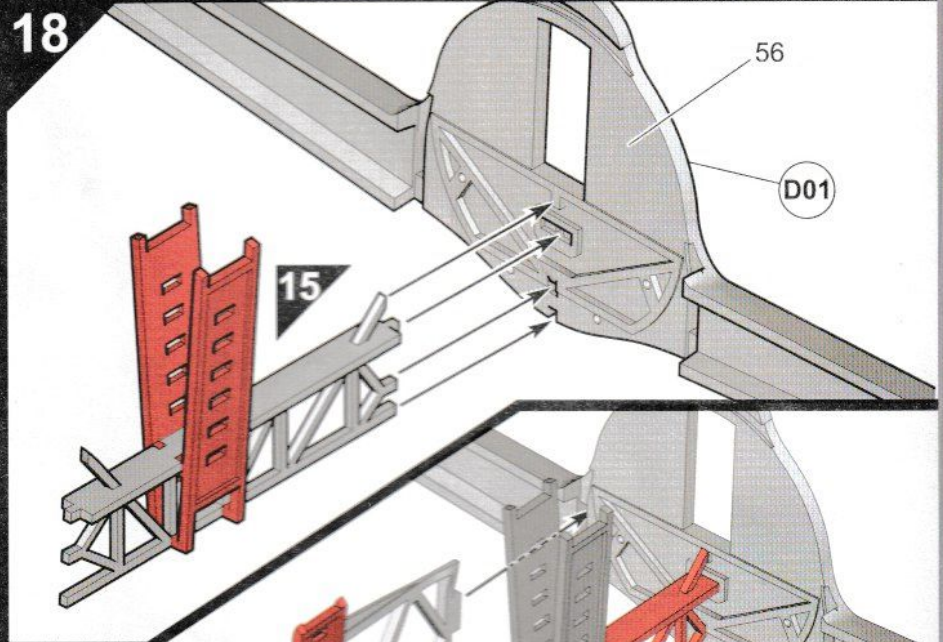
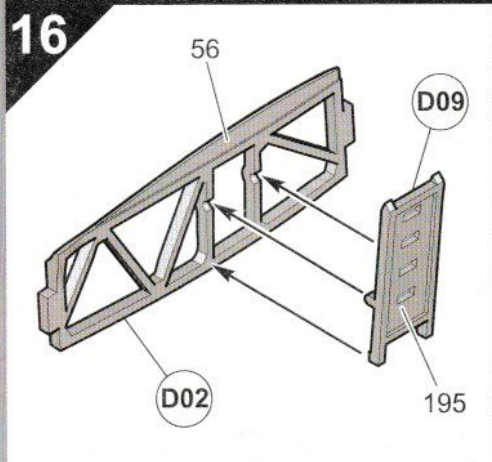
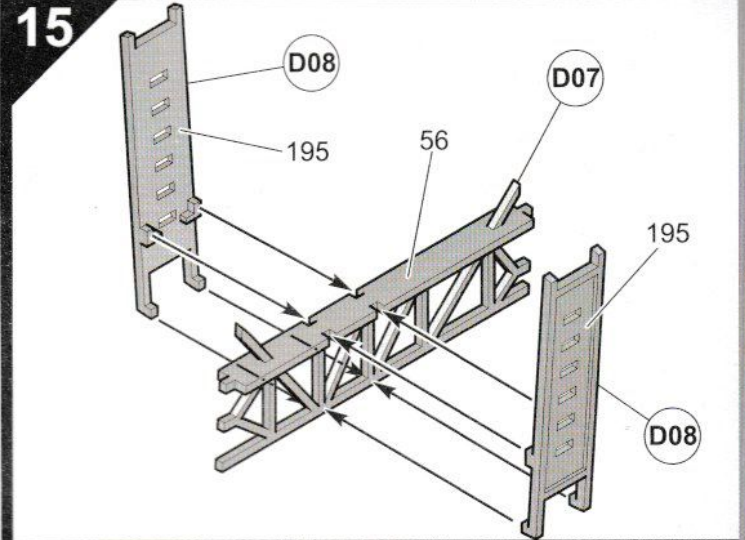
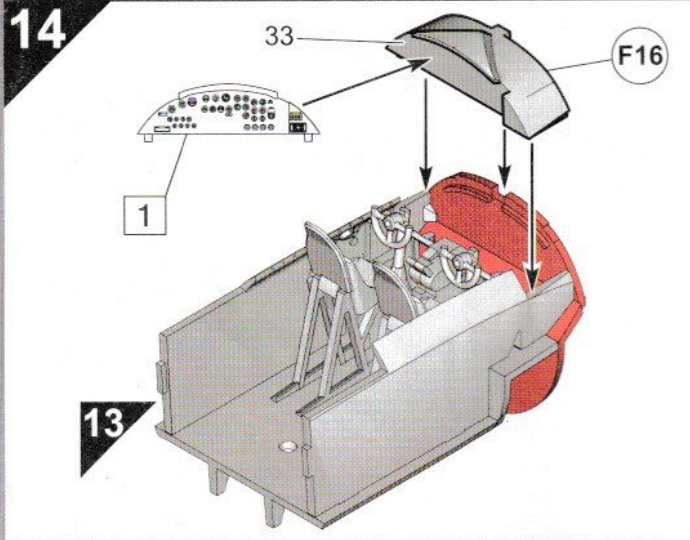
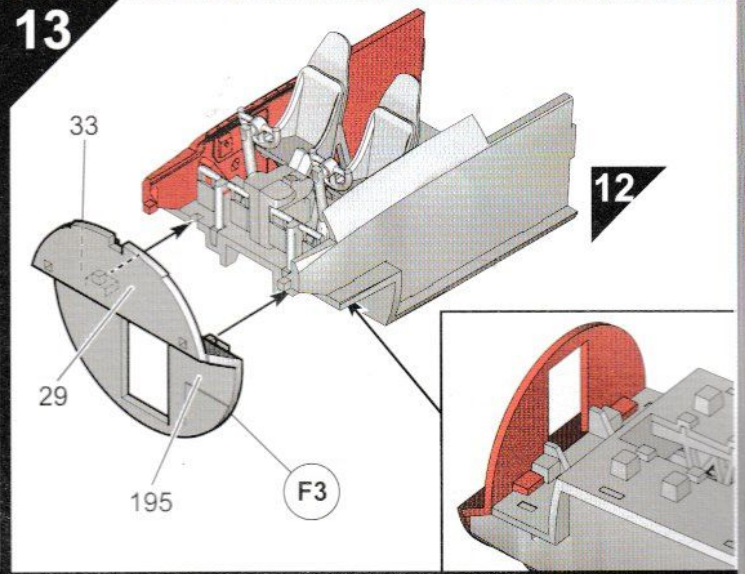
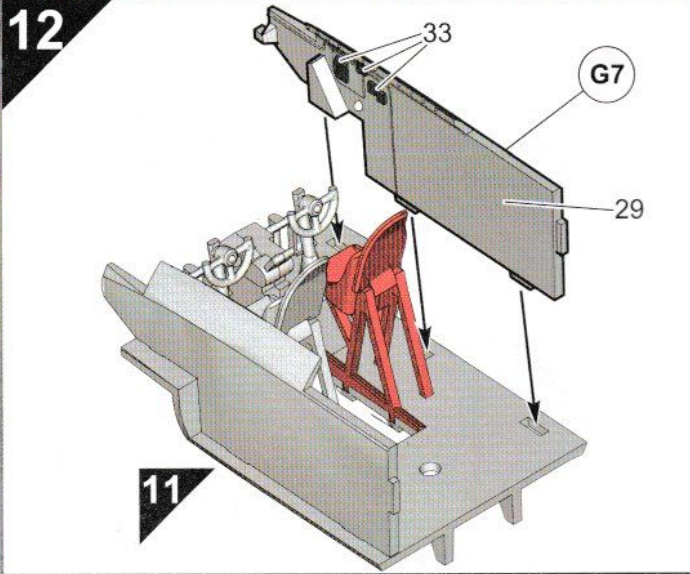

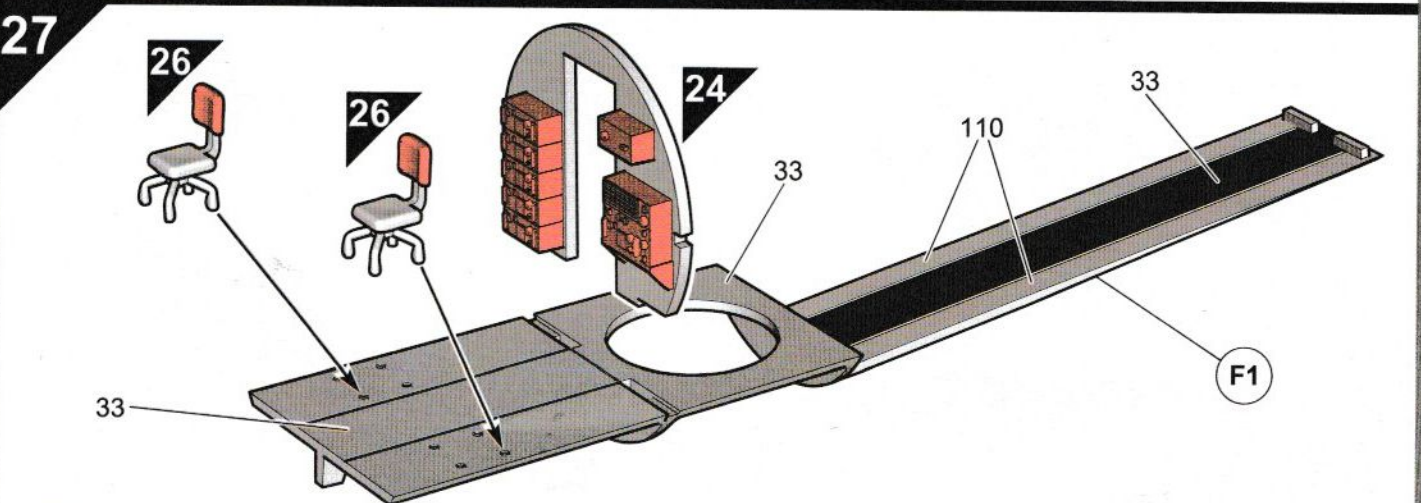
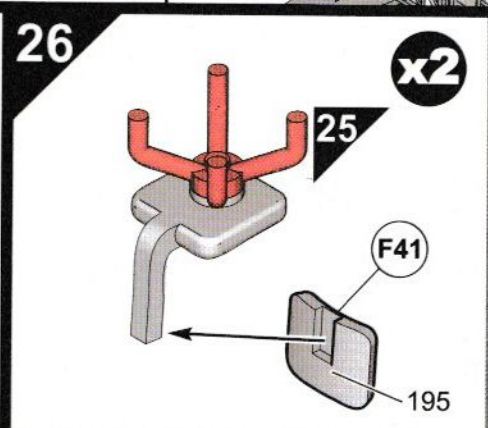
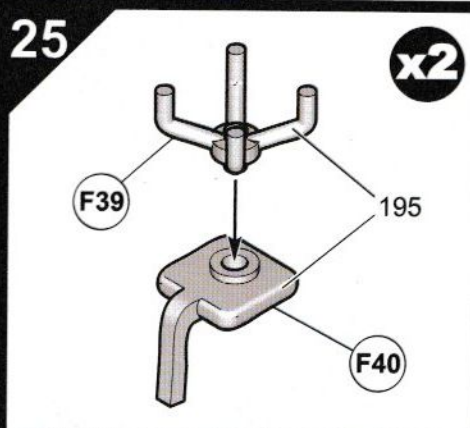
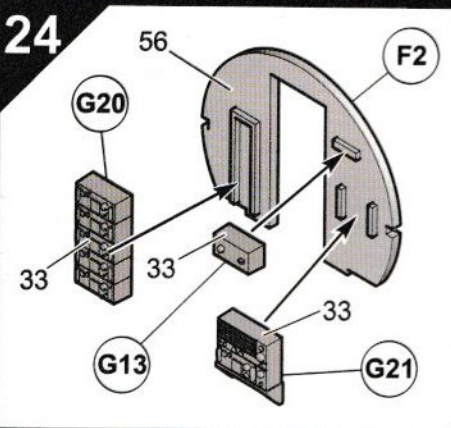
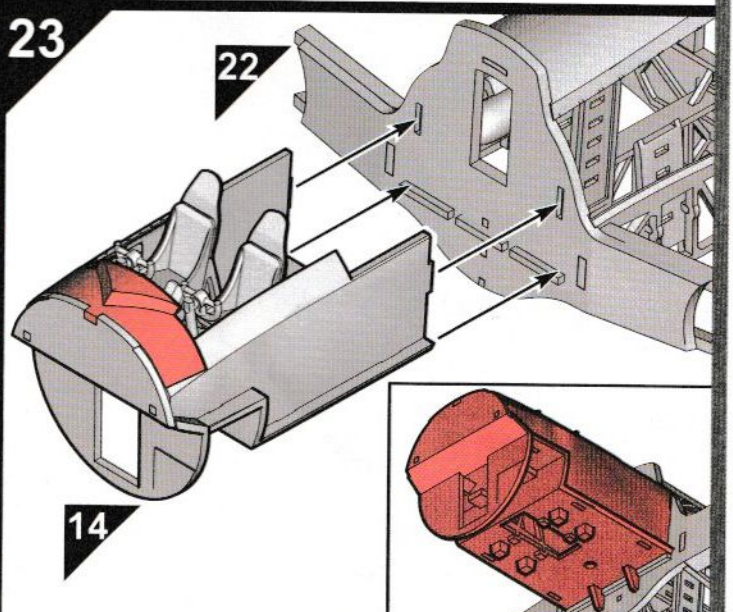
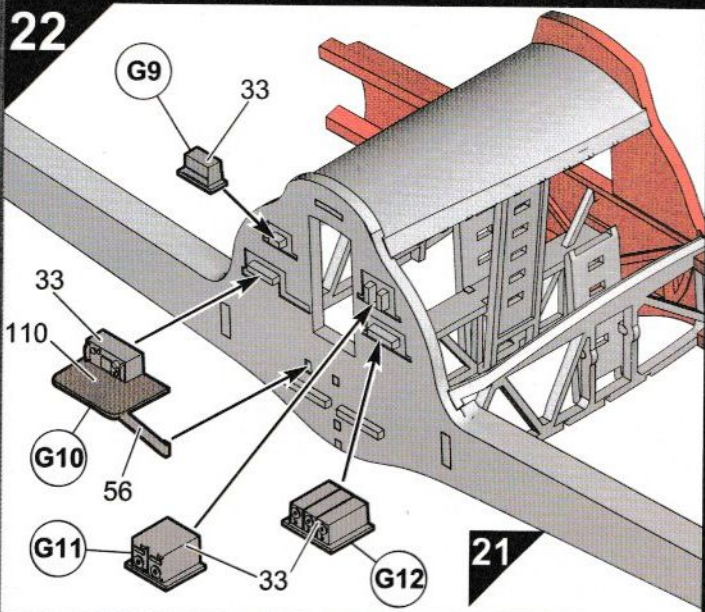
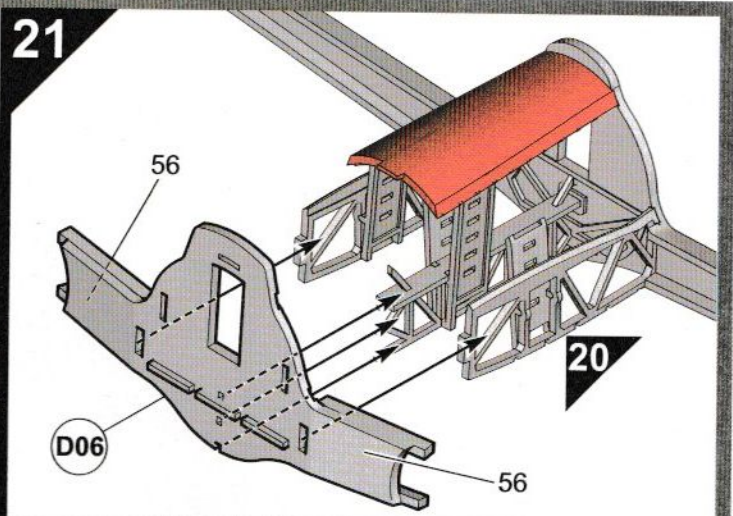
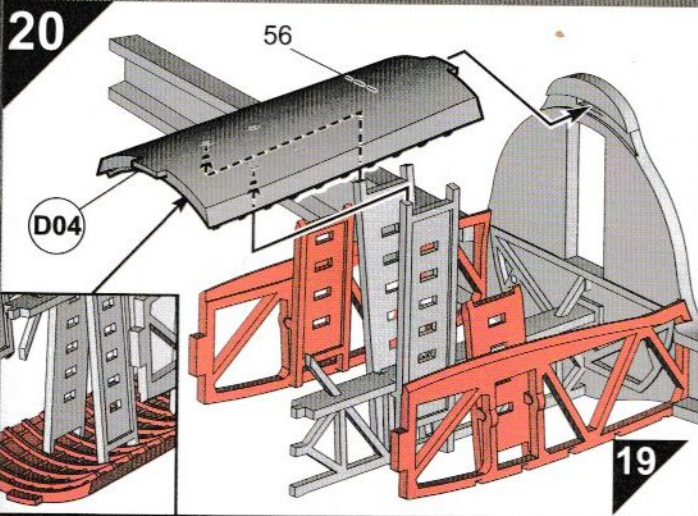

28

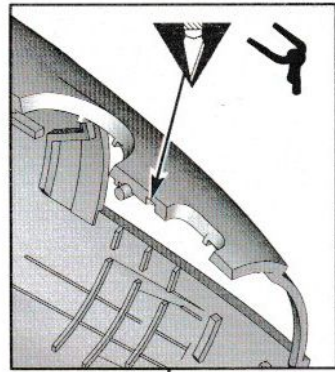

AF1006 AIRCRAFT STAND
SOLD SEPARATELY



K22

56

1.0mmØ

0.8mmØ

A1

56

1.0mmØ

K21

56

0.8mmØ

1.0mmØ

29

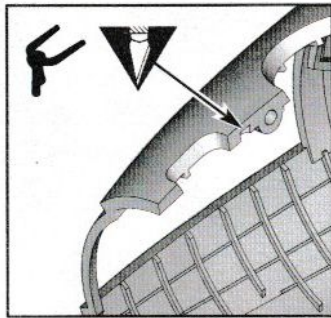

A2

56



AF1006 AIRCRAFT STAND
SOLD SEPARATELY

30

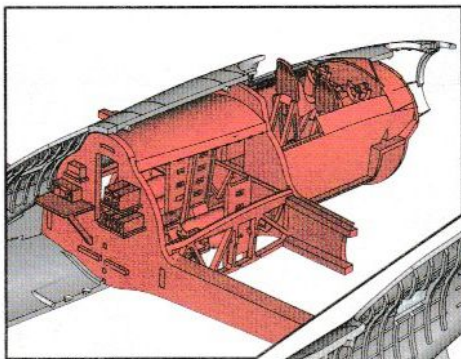

28

23

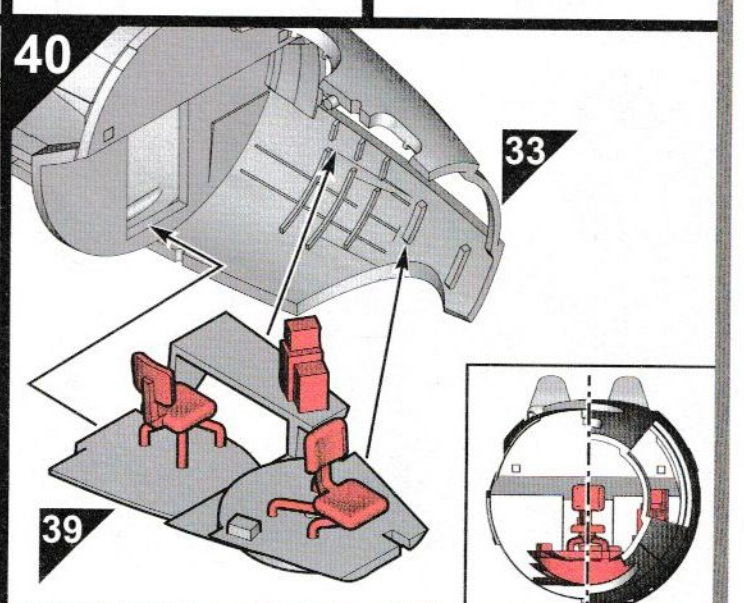
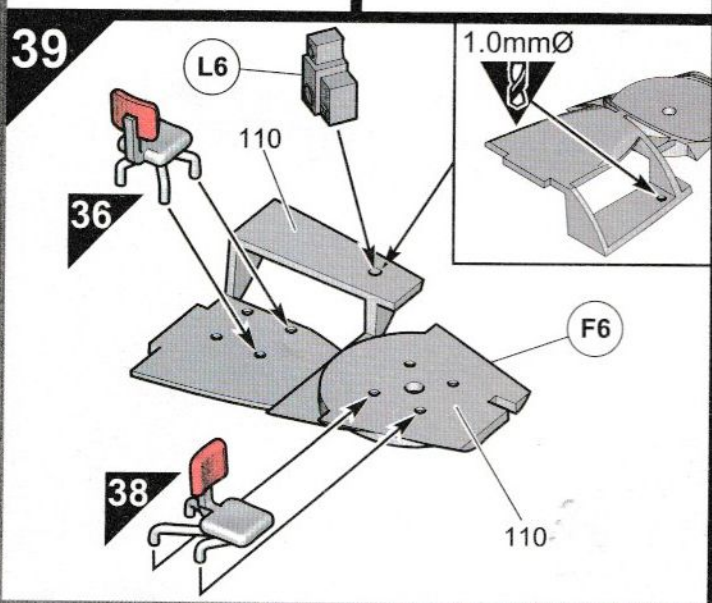
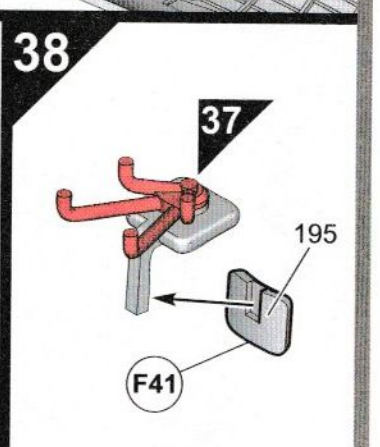
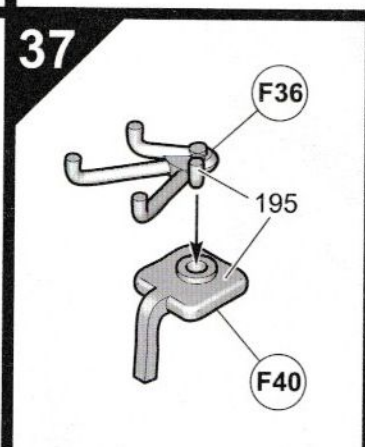
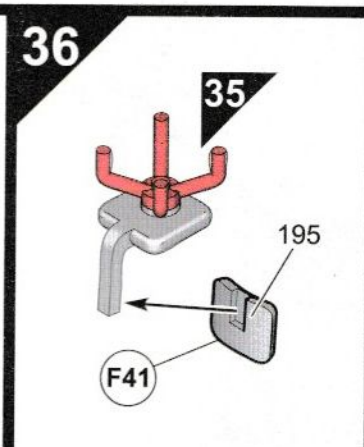
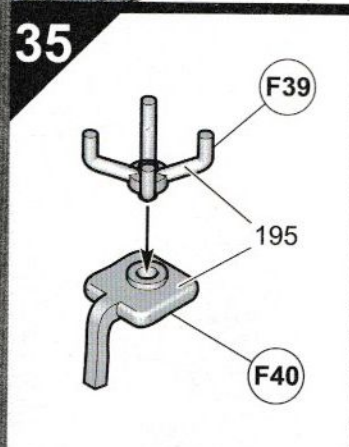
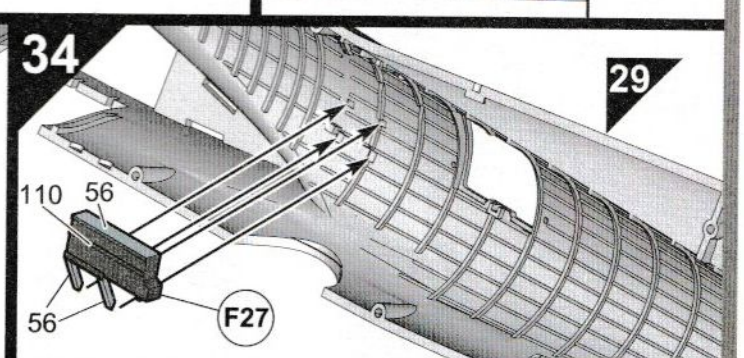
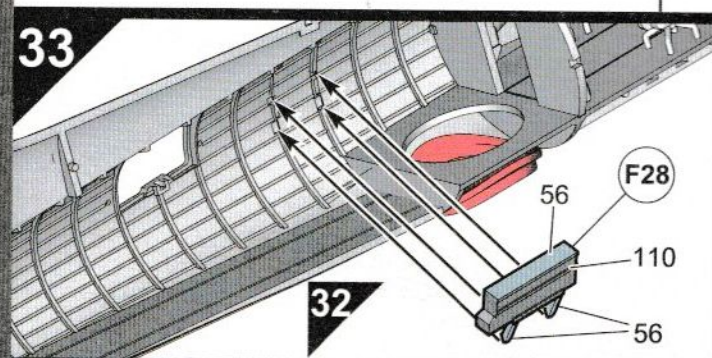
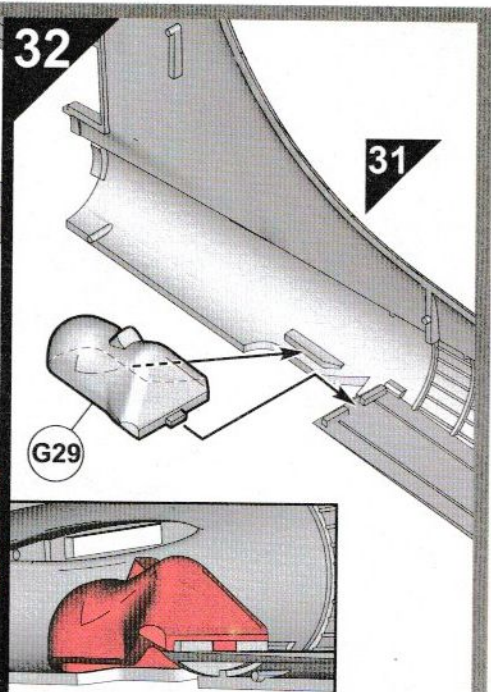
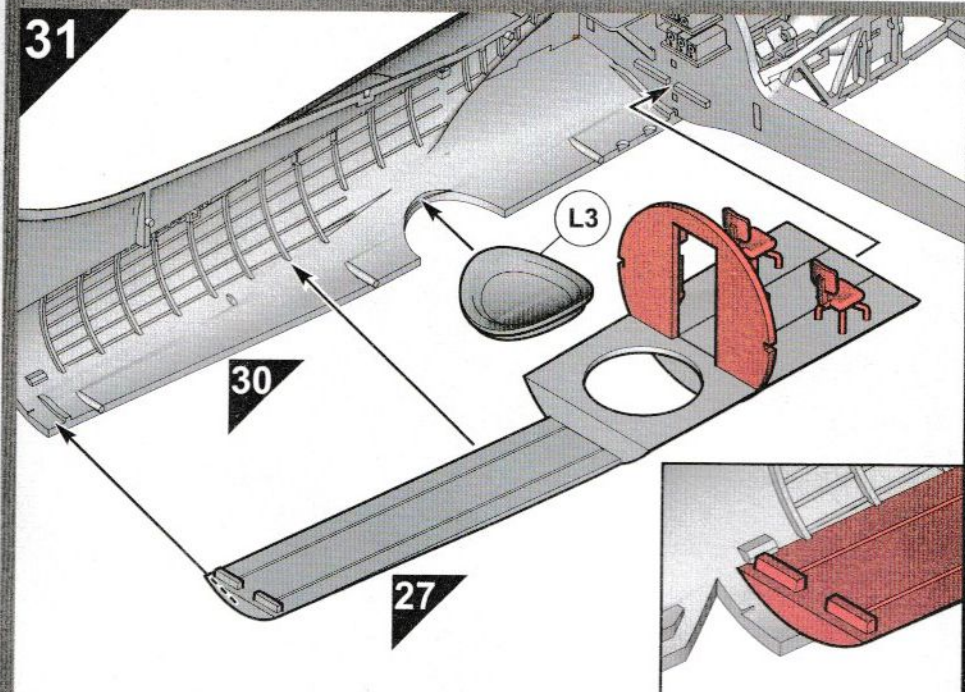

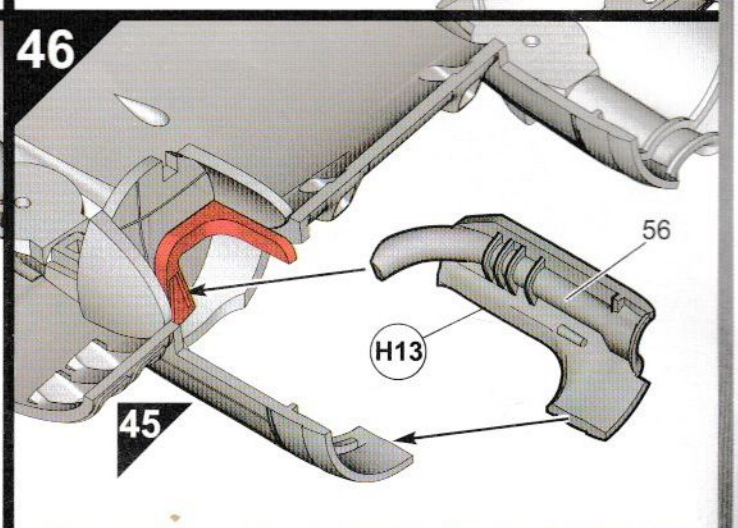
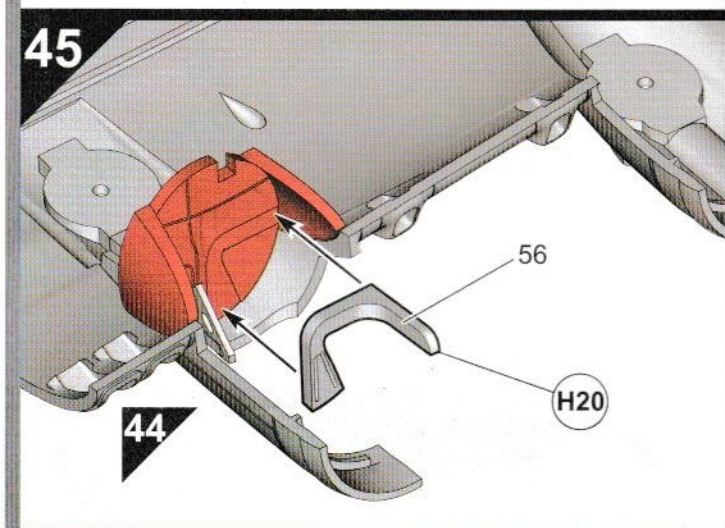
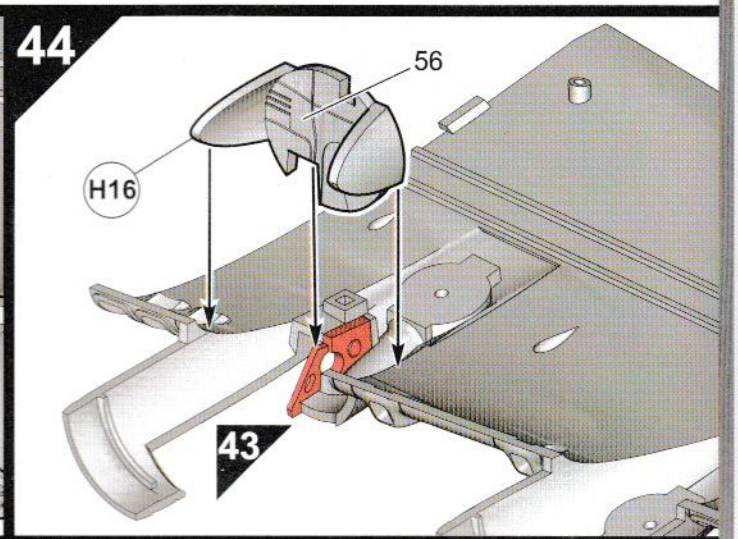
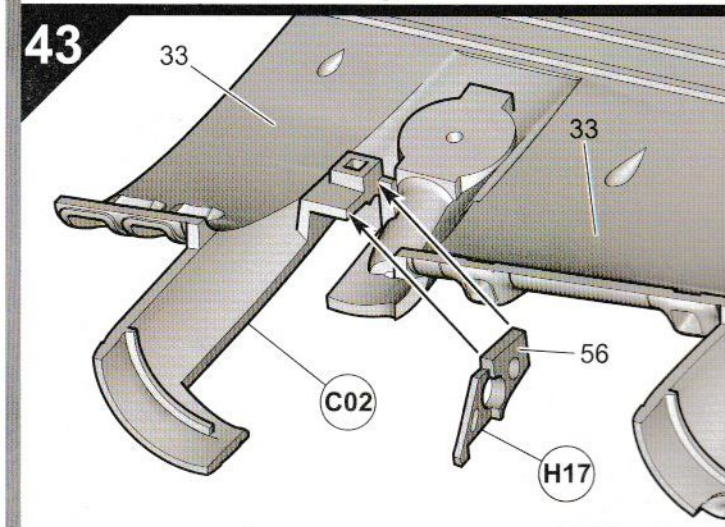
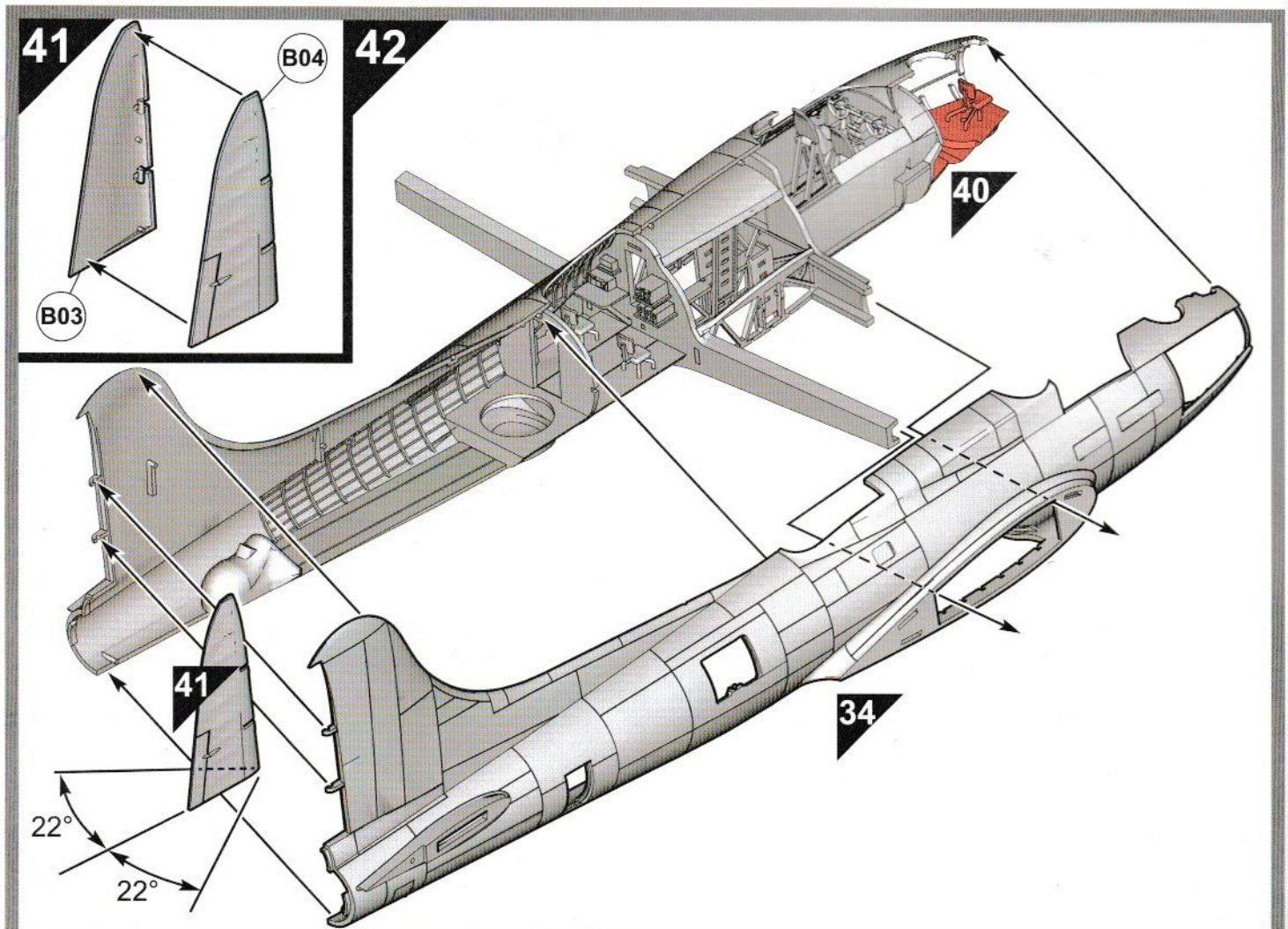

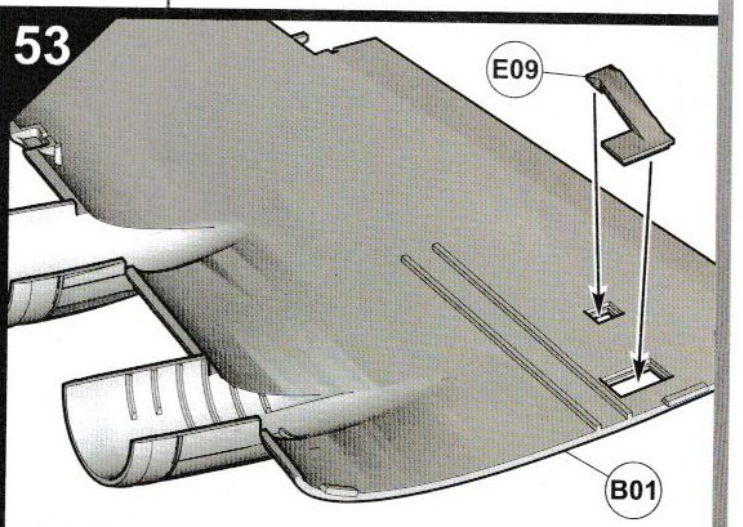
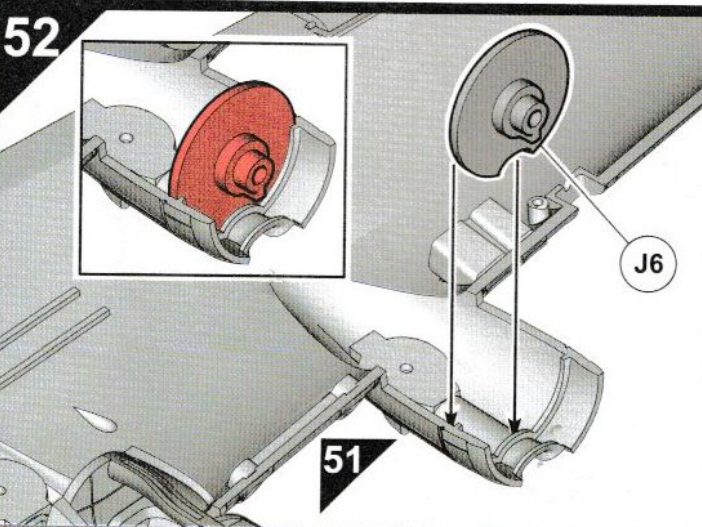
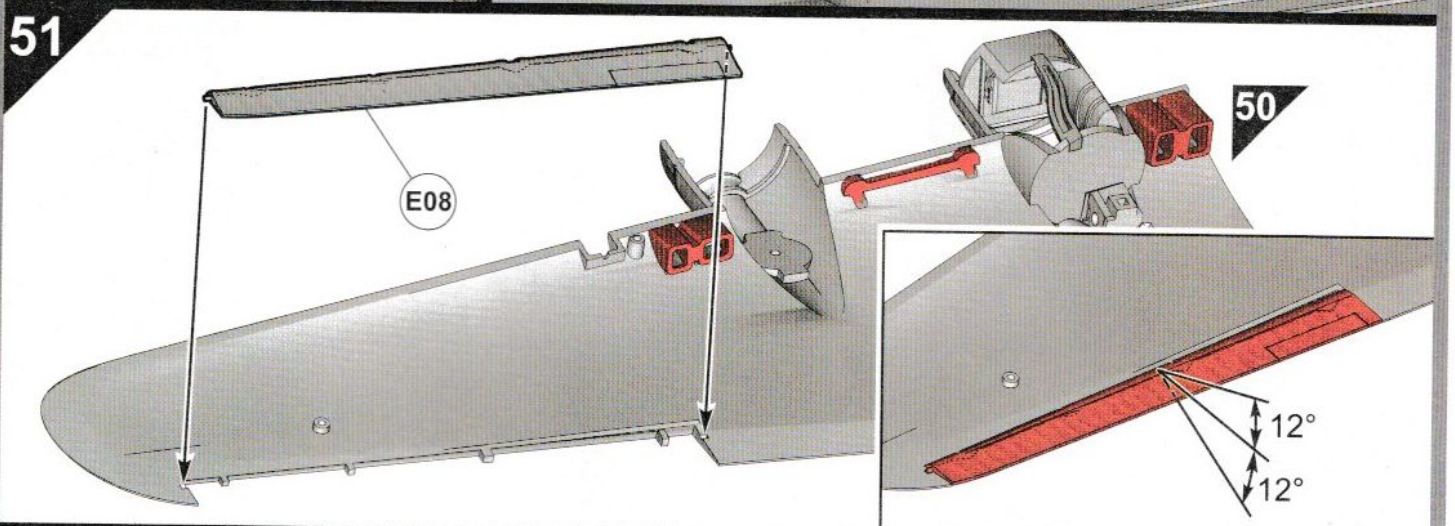
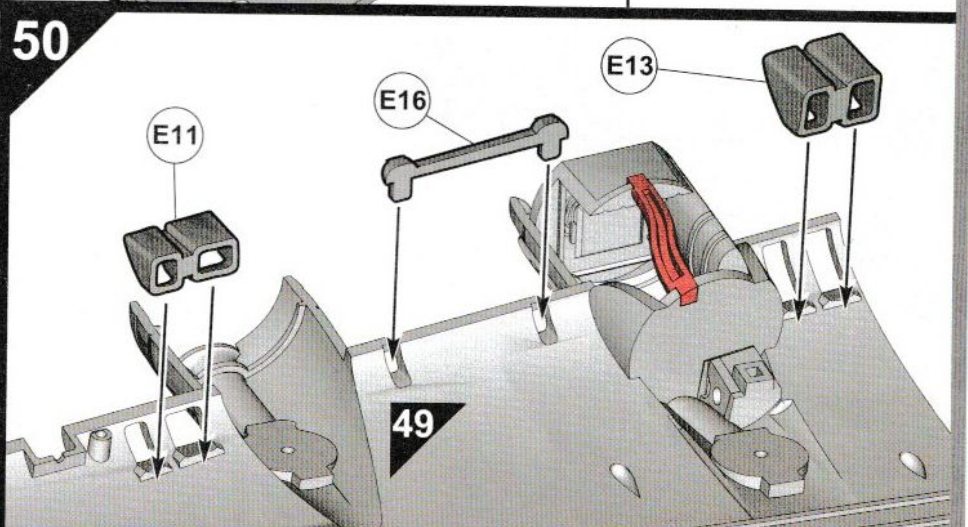
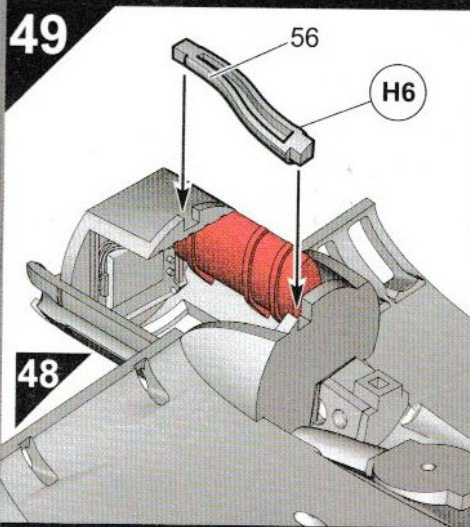
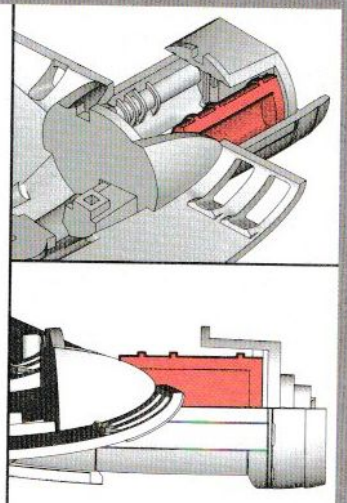
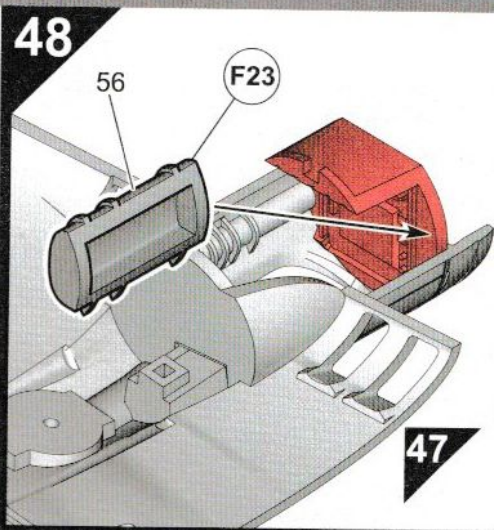
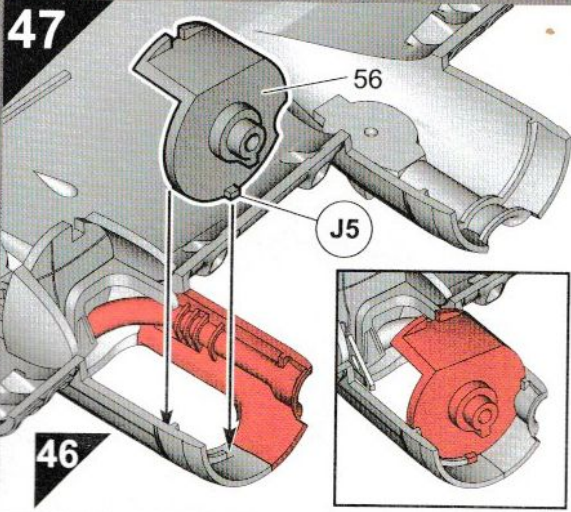

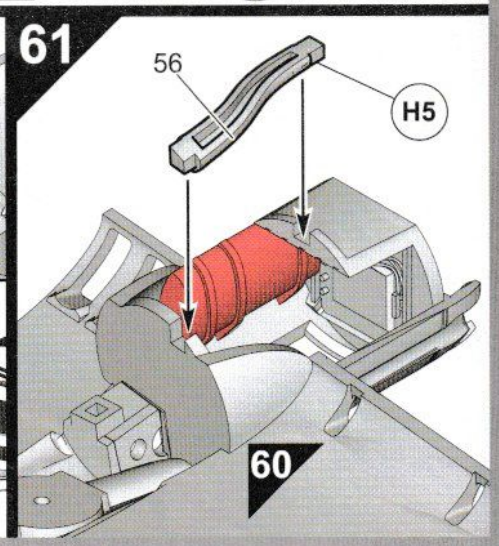
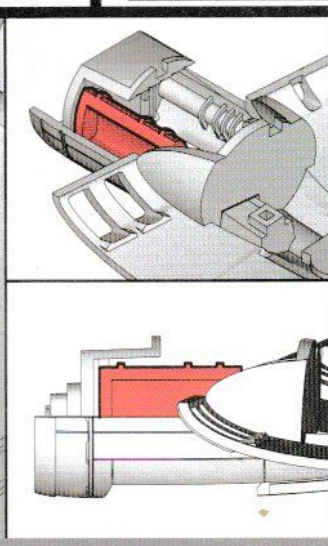
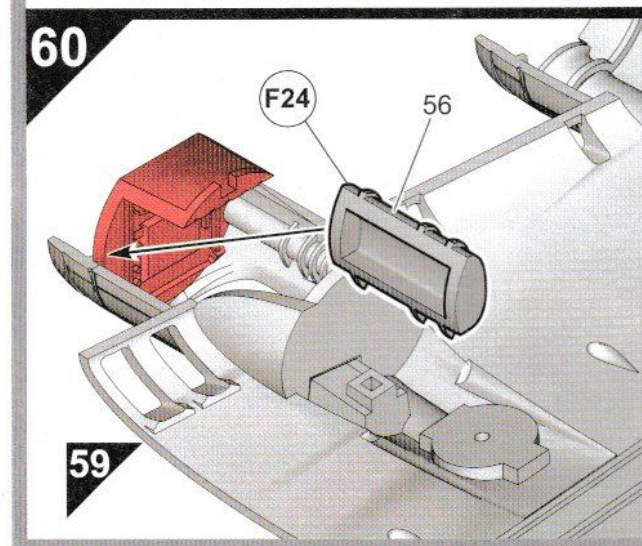
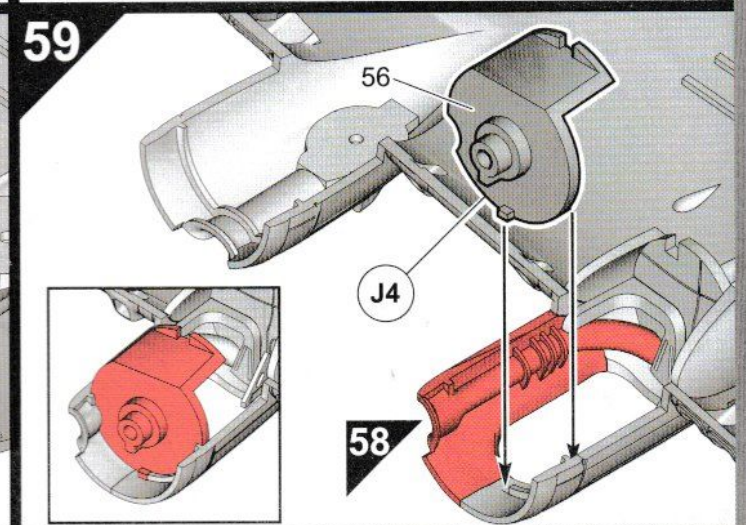
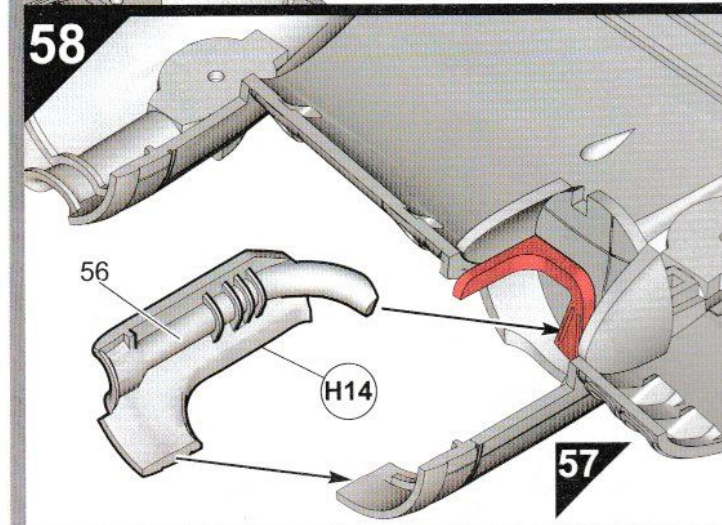
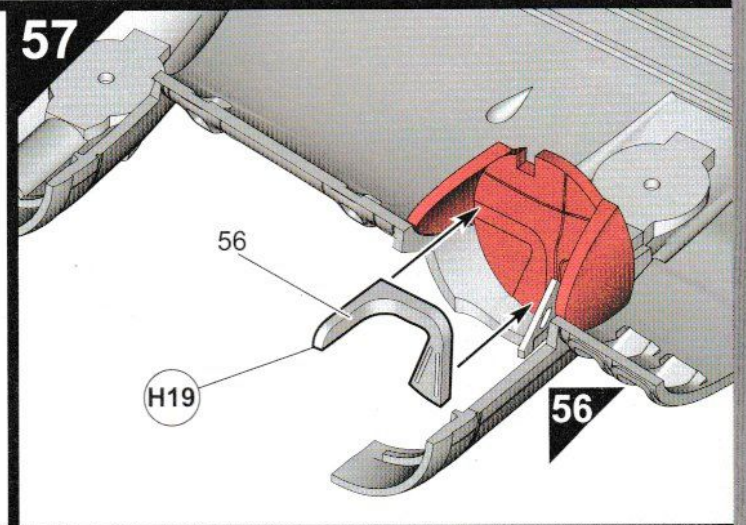
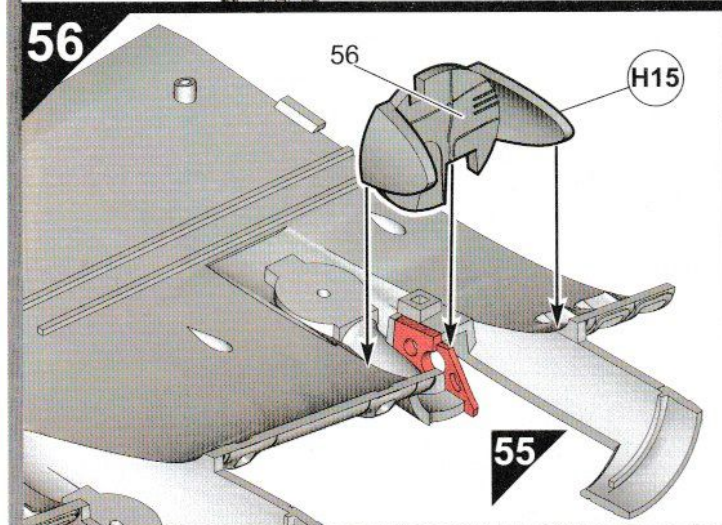
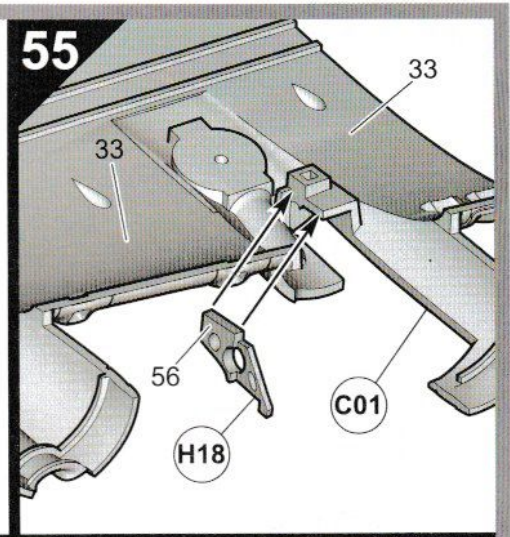
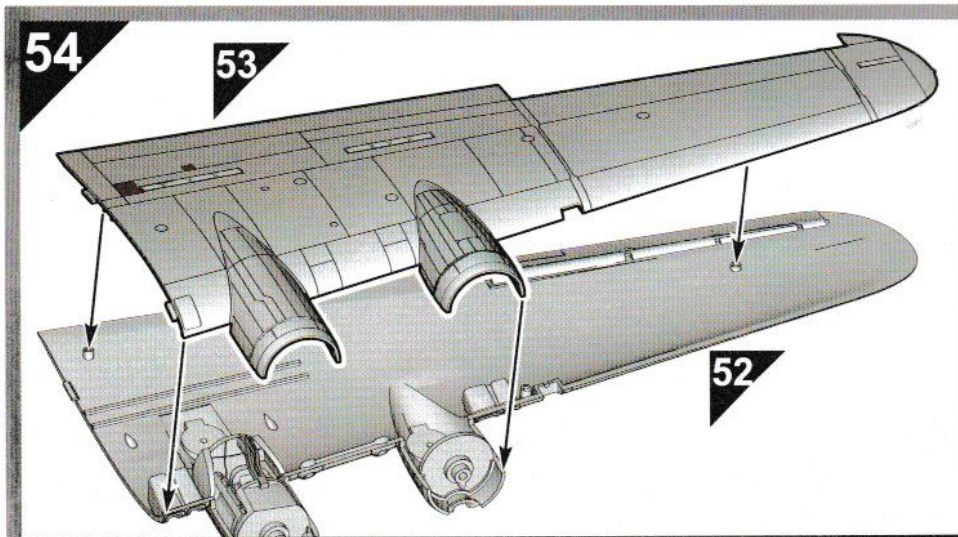

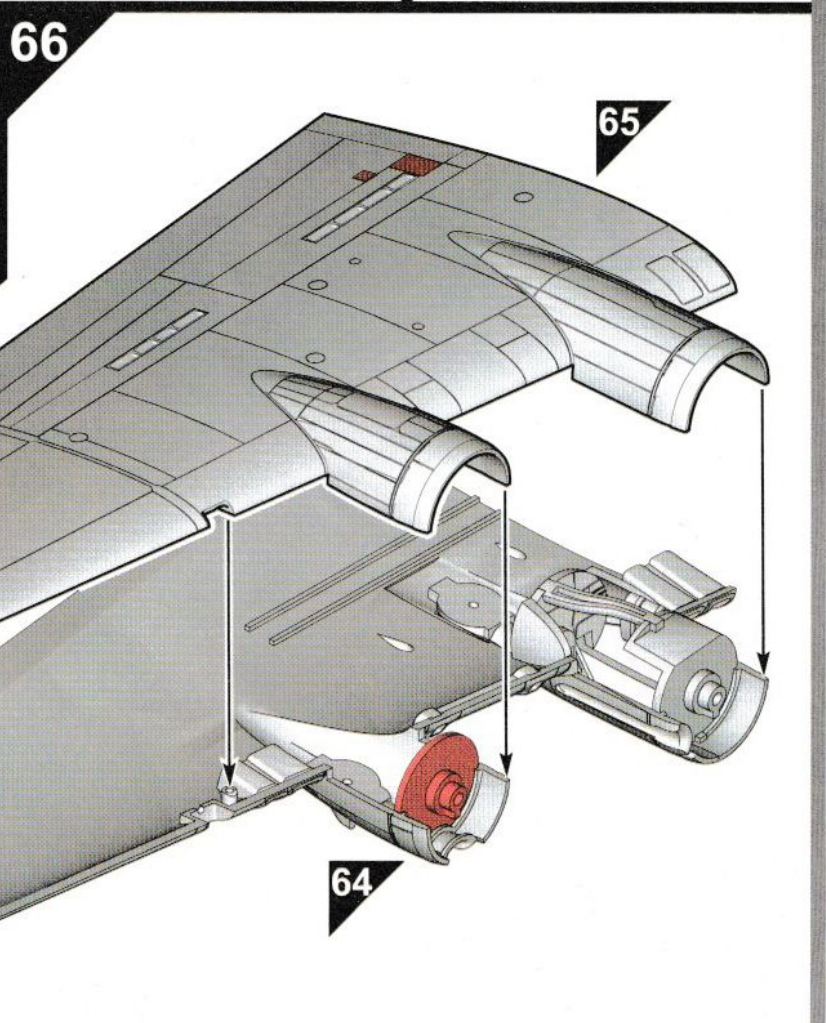
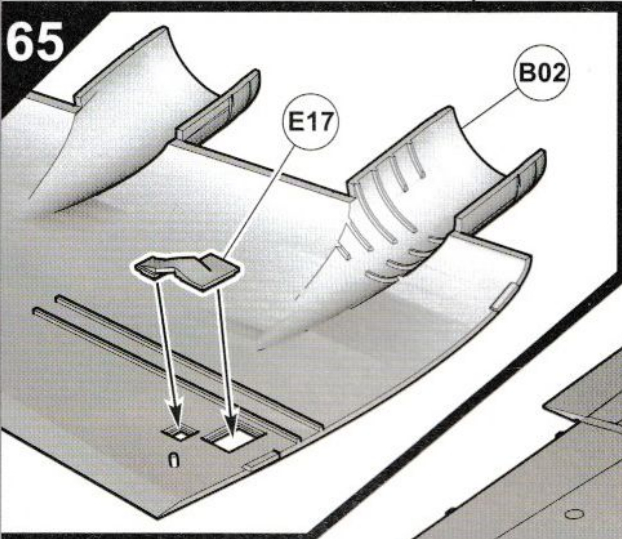
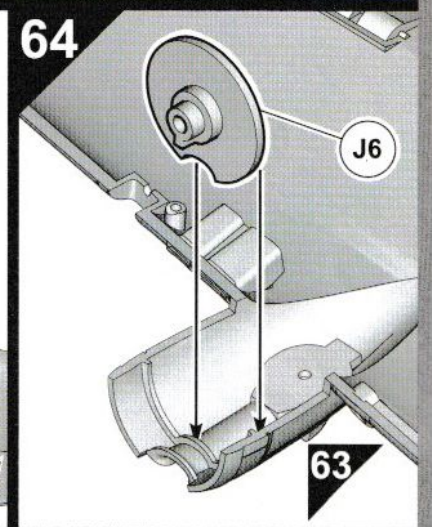
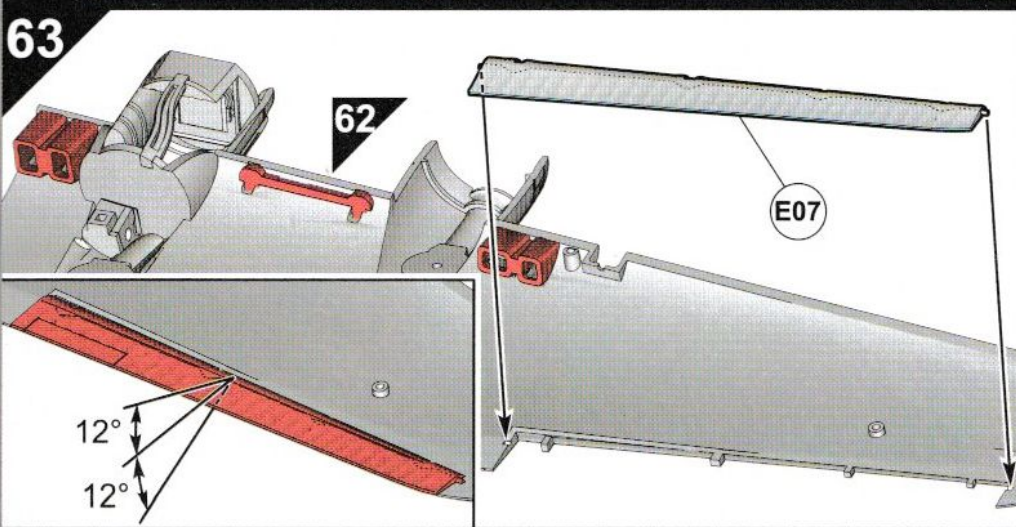
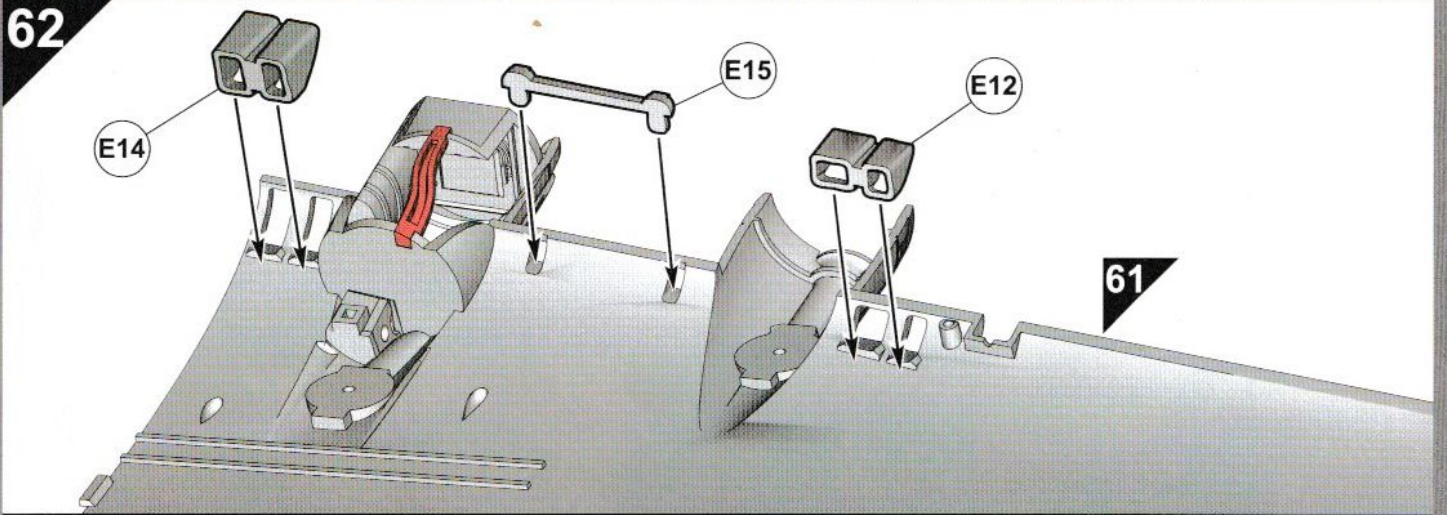

67

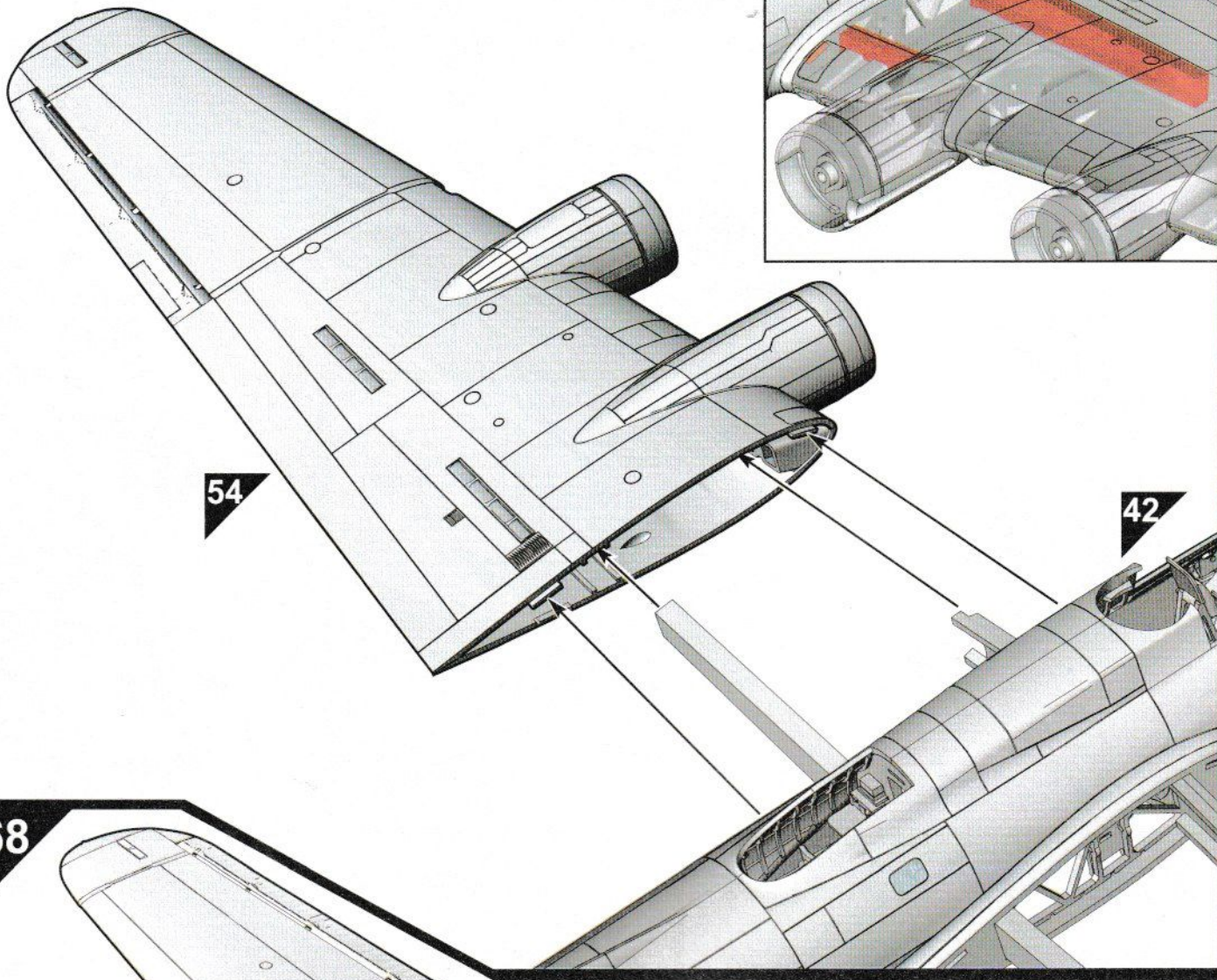

68

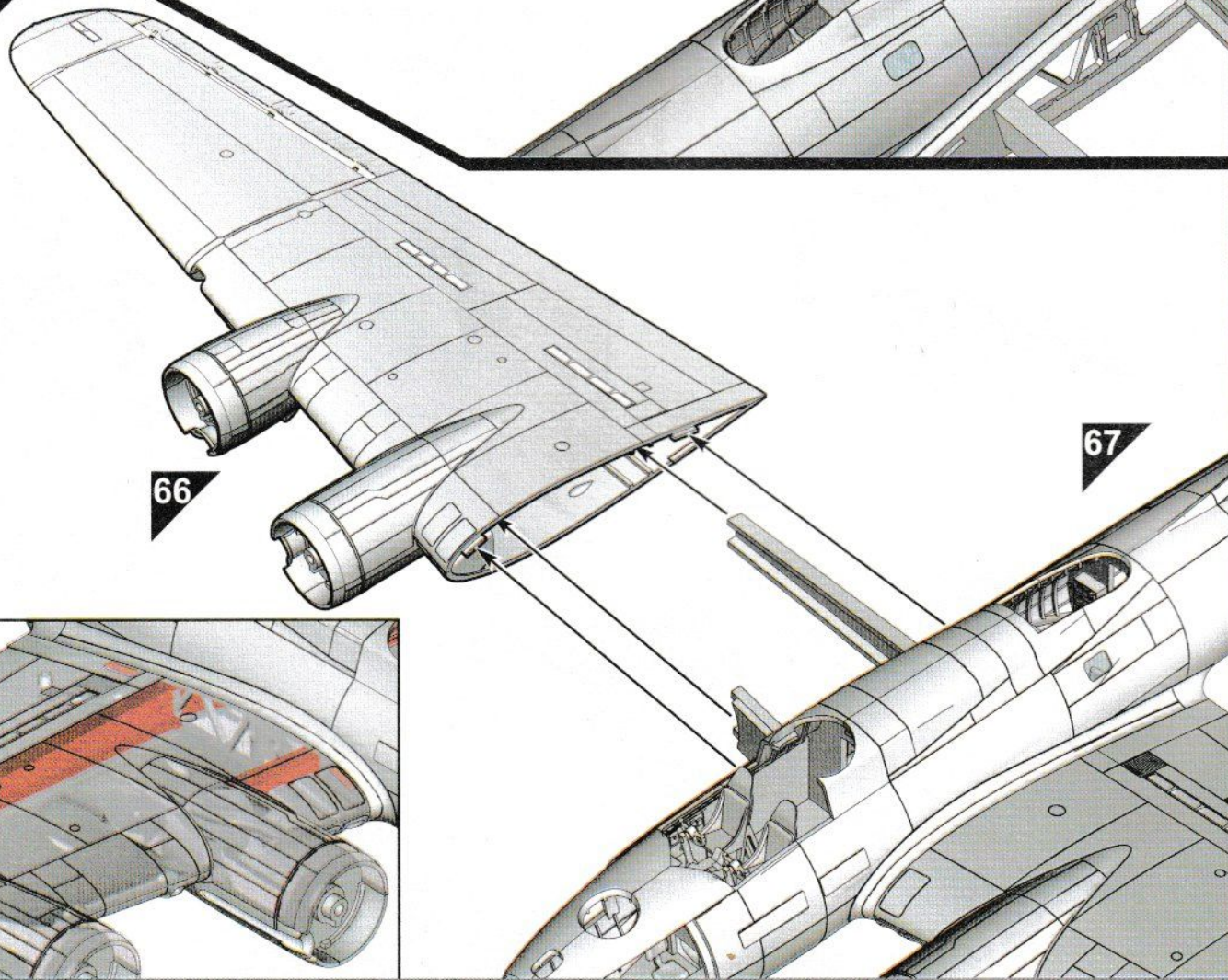

69

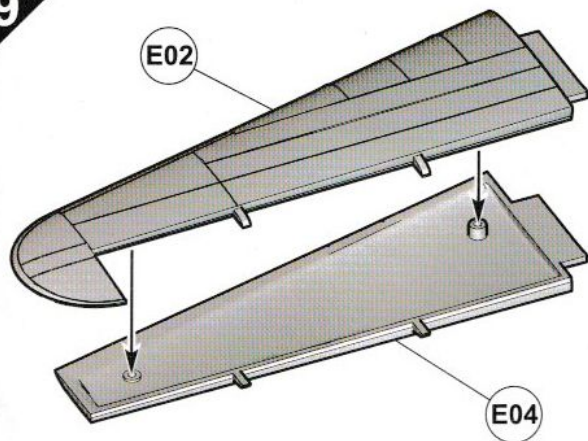

70

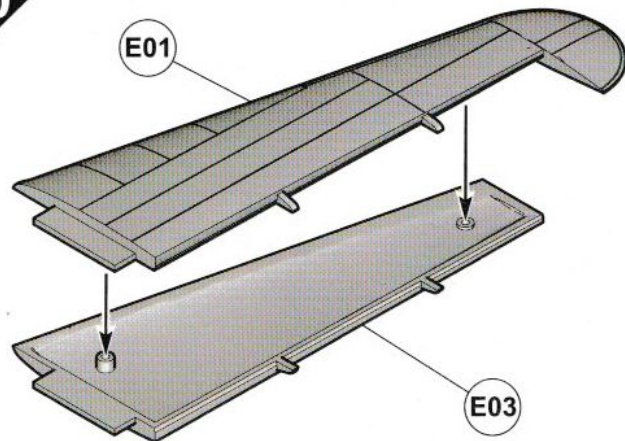

71

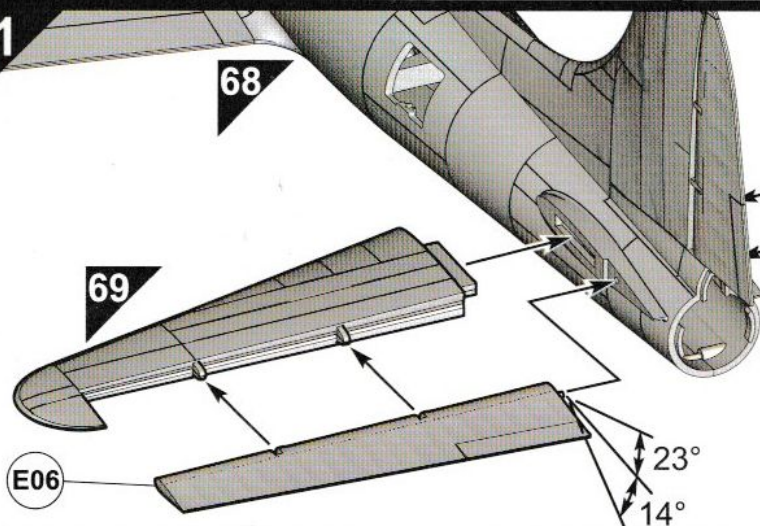

70

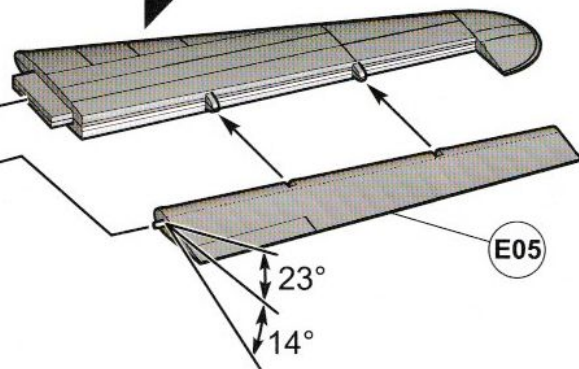

72

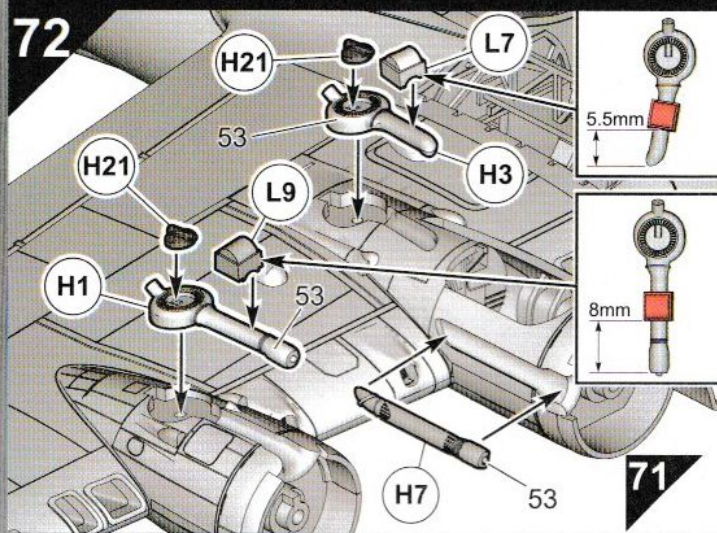

73

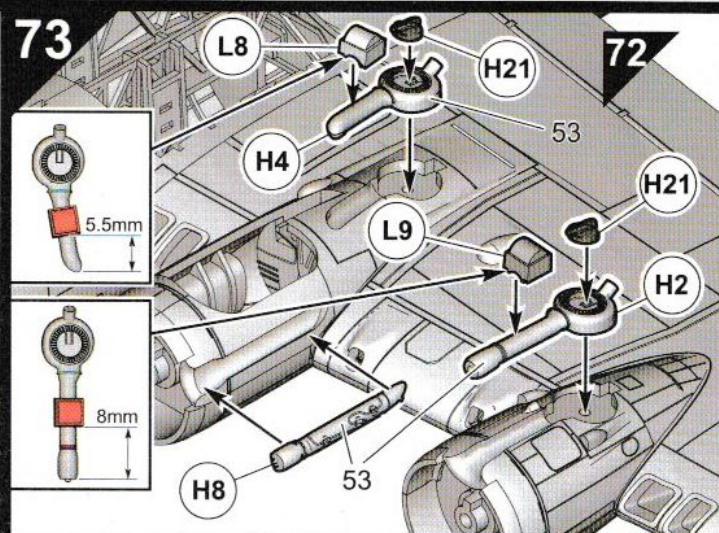

74

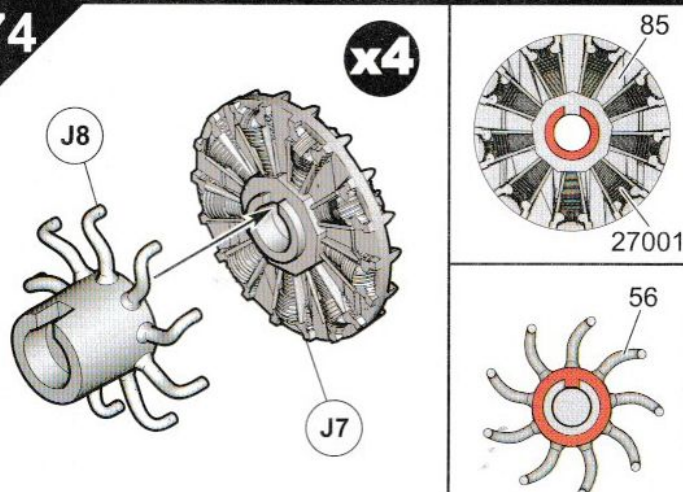

75

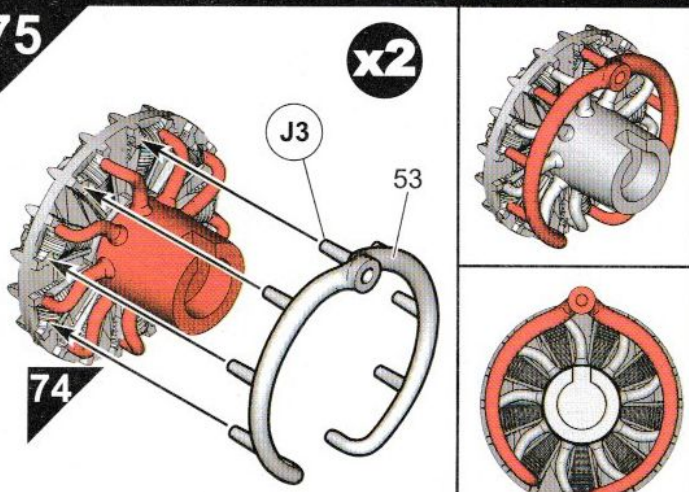

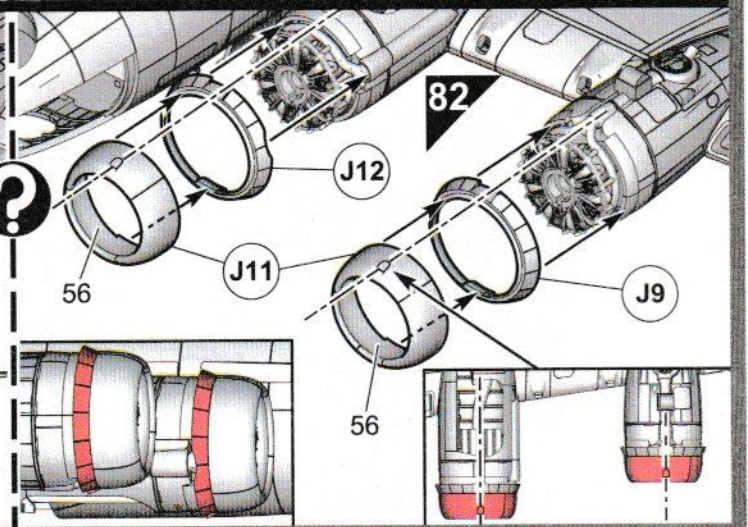
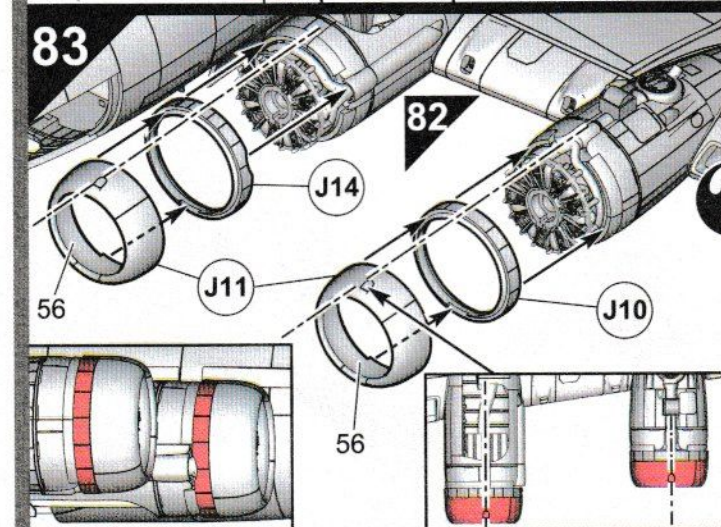
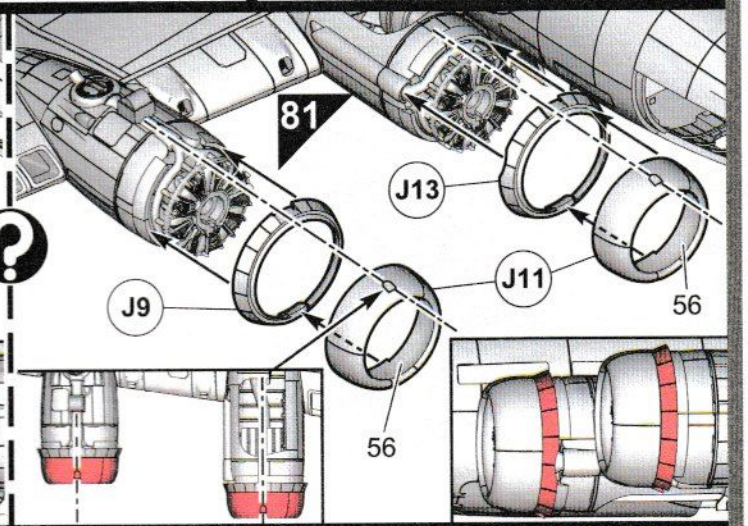
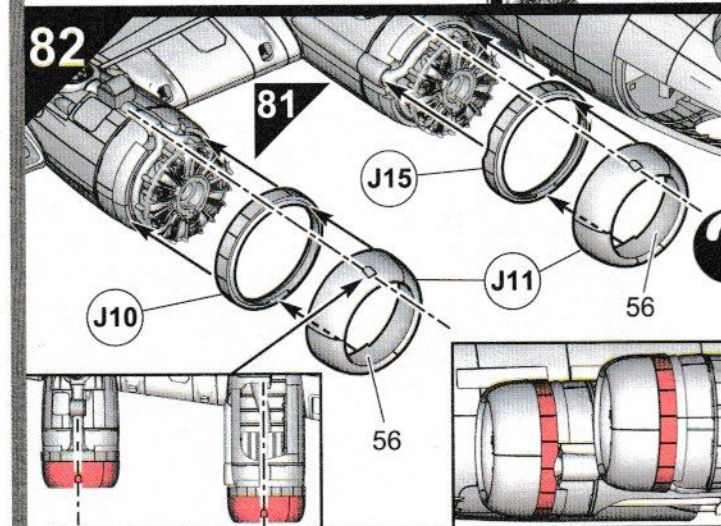
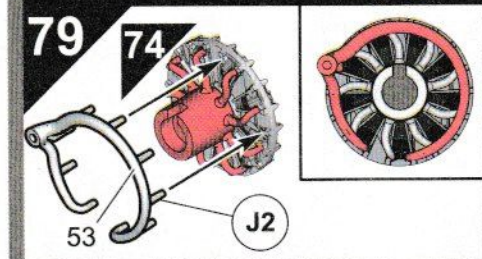
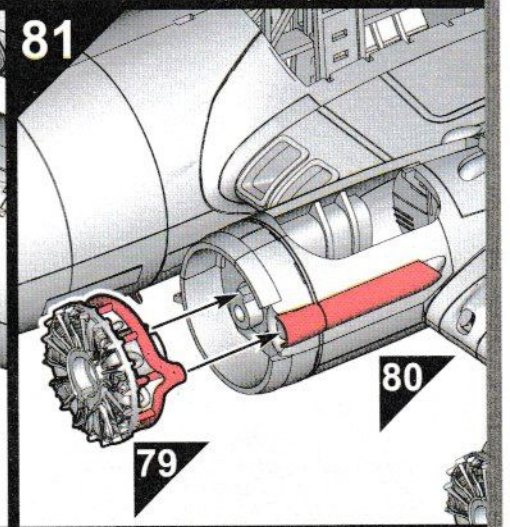
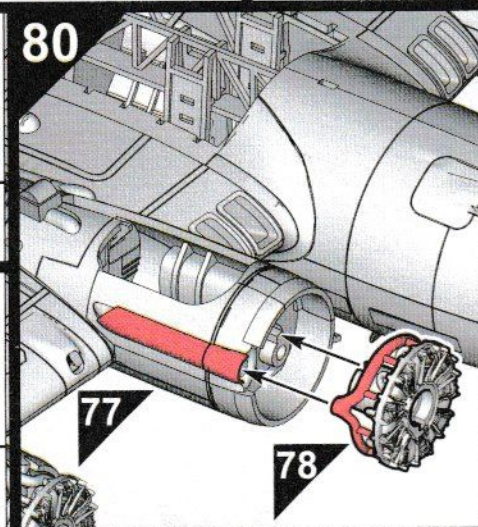
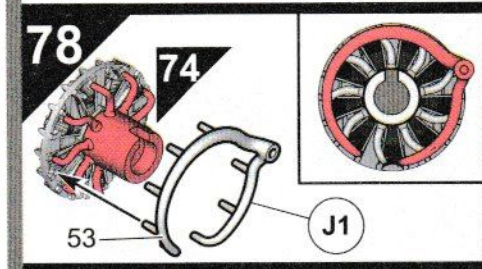
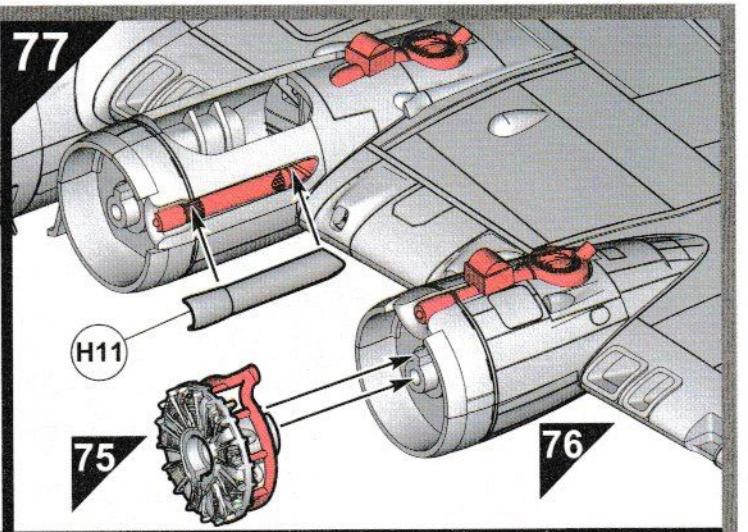
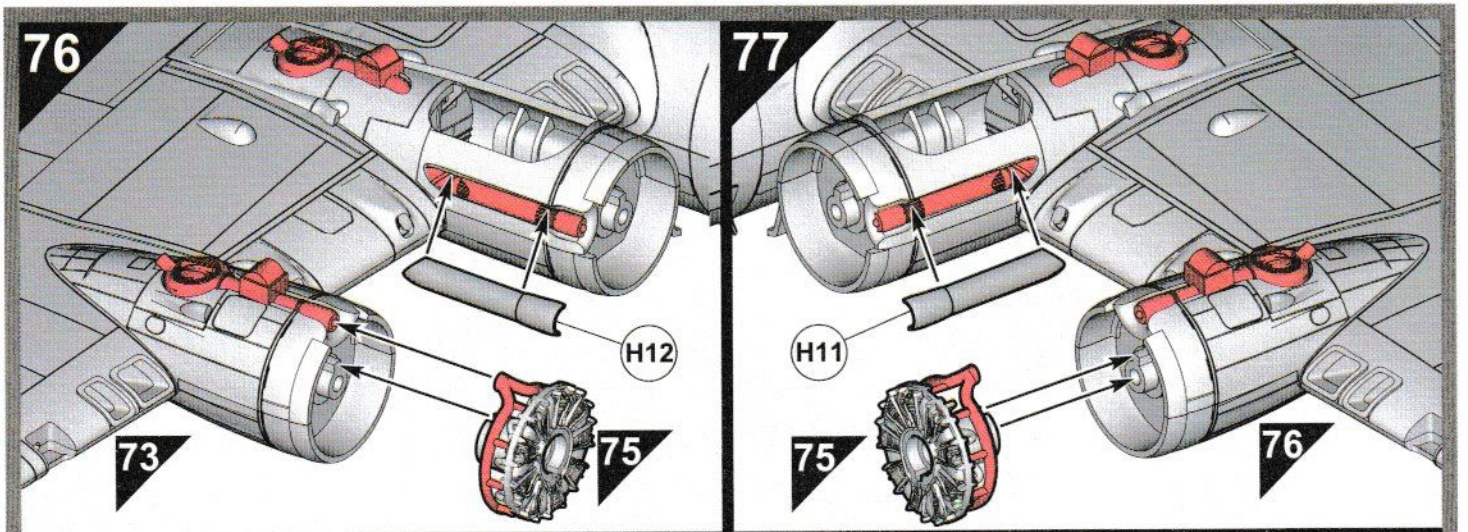

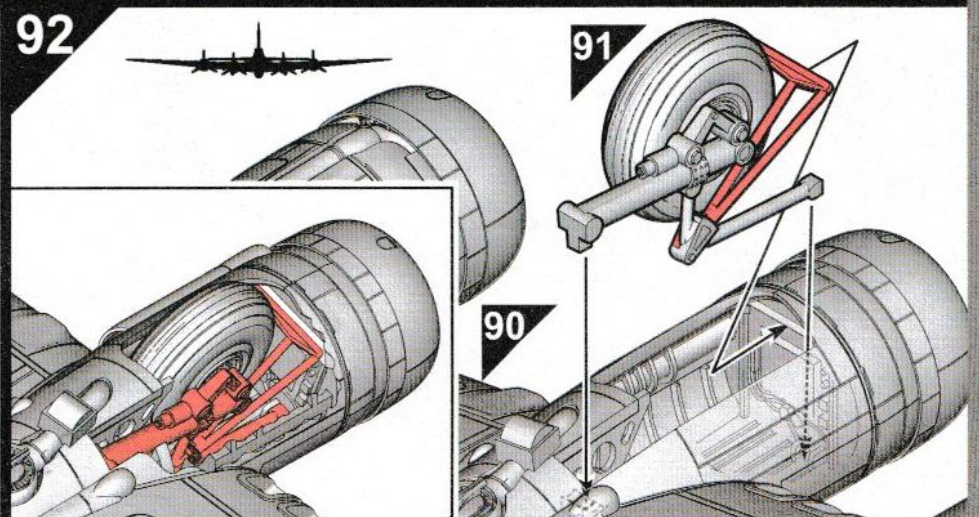
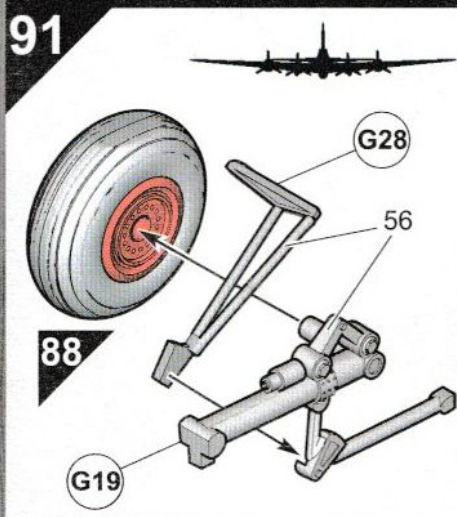
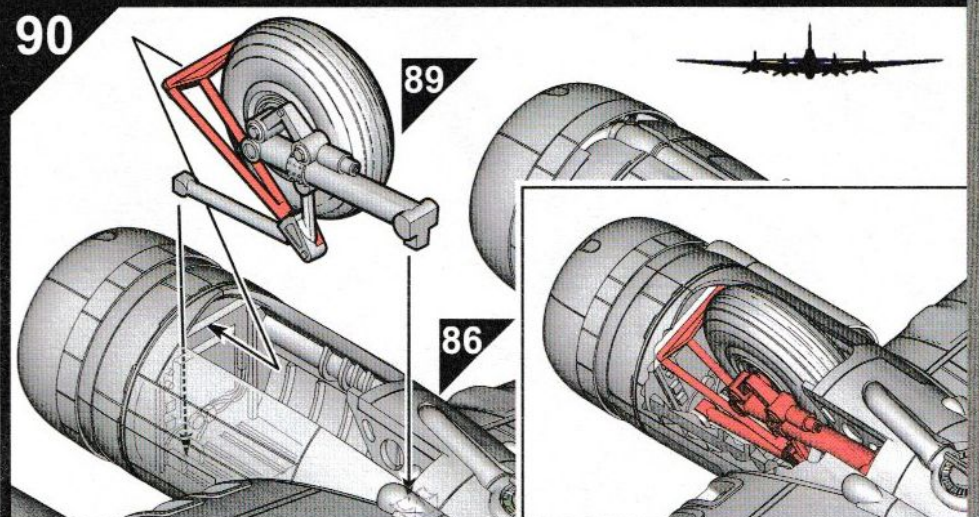
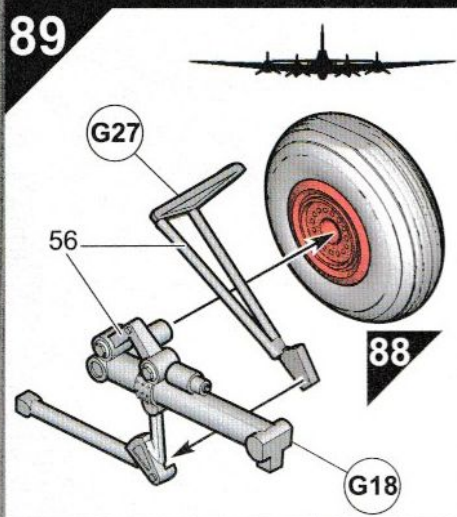
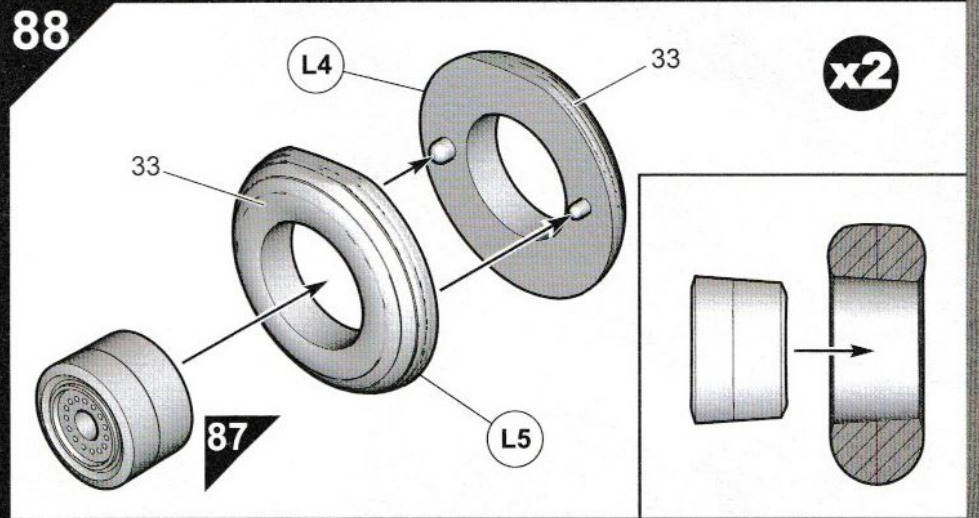
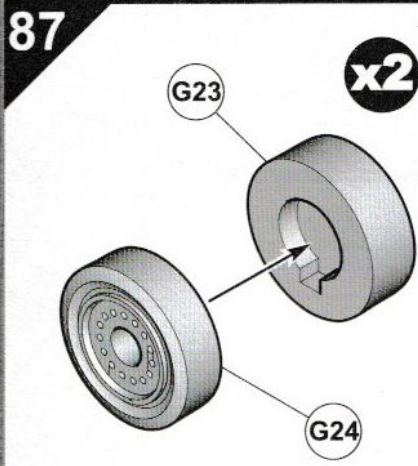
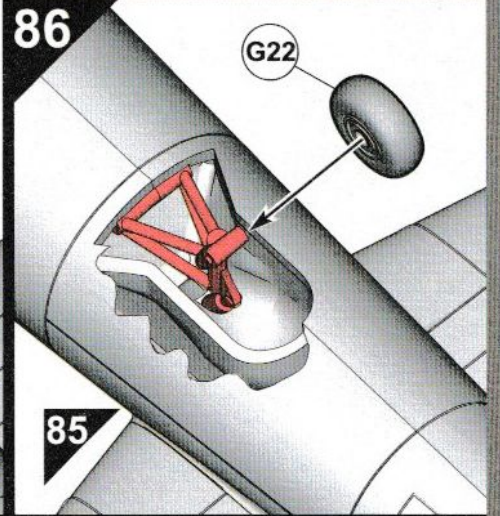
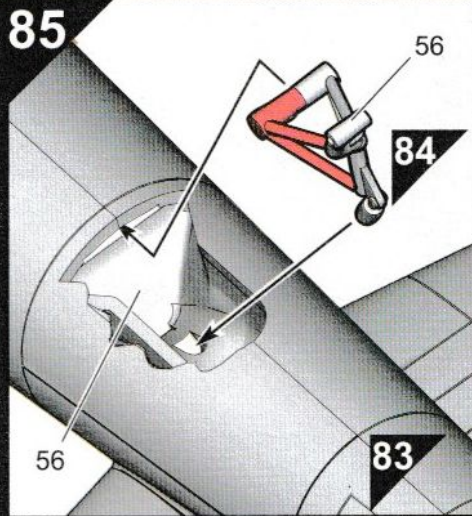
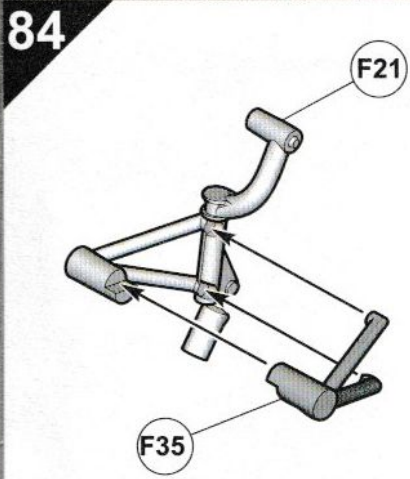

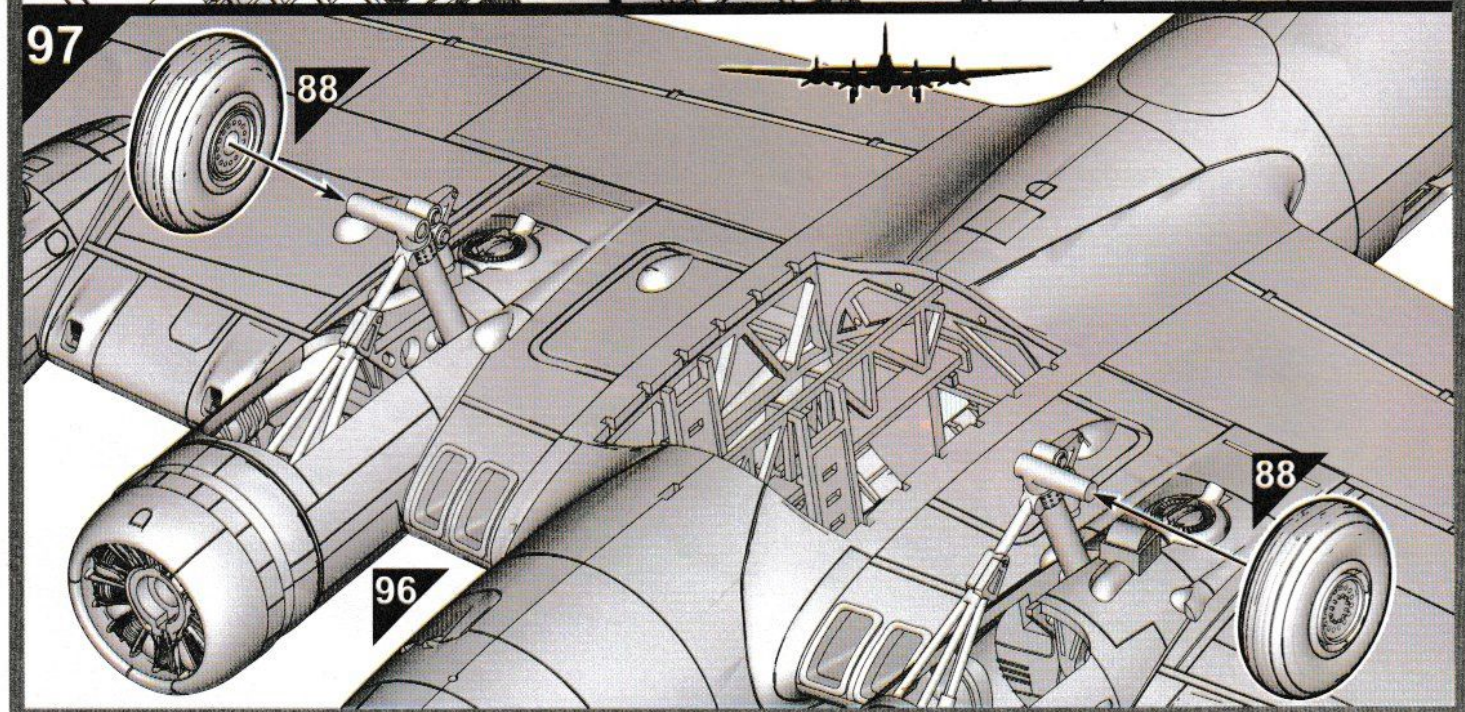
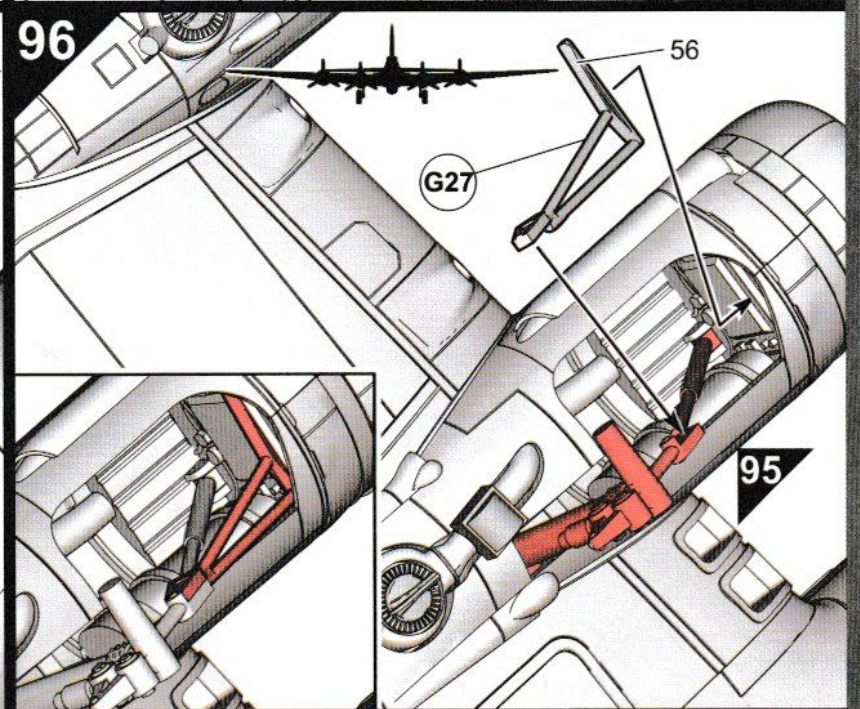
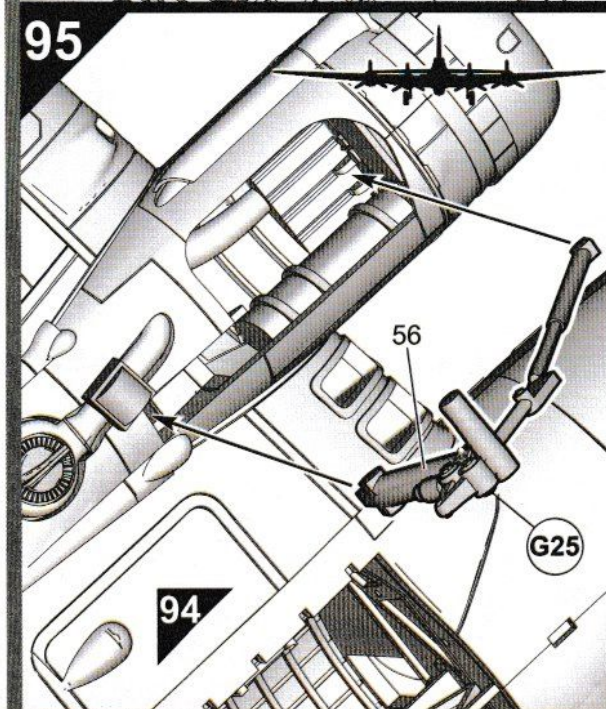
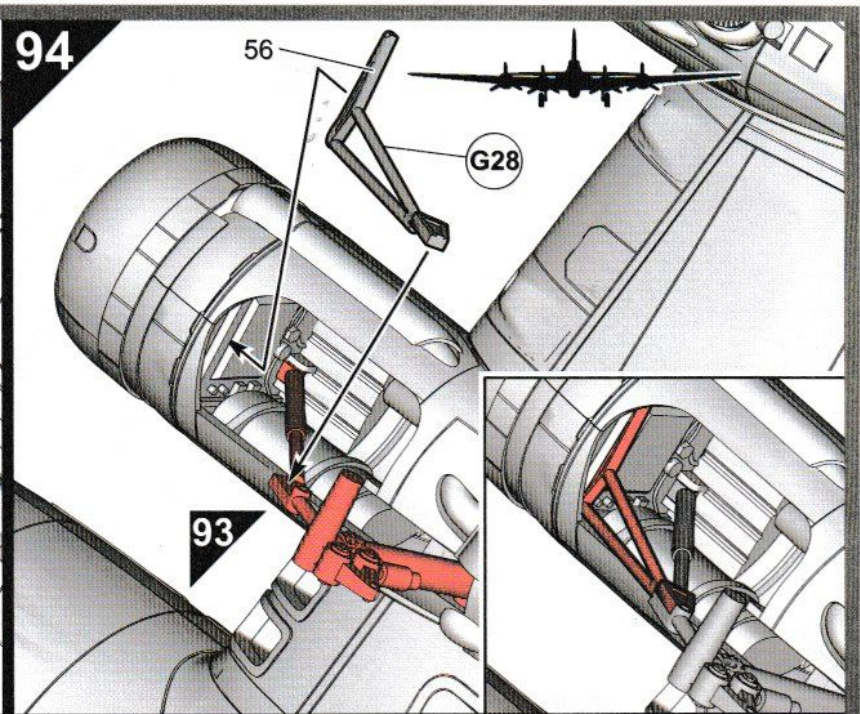
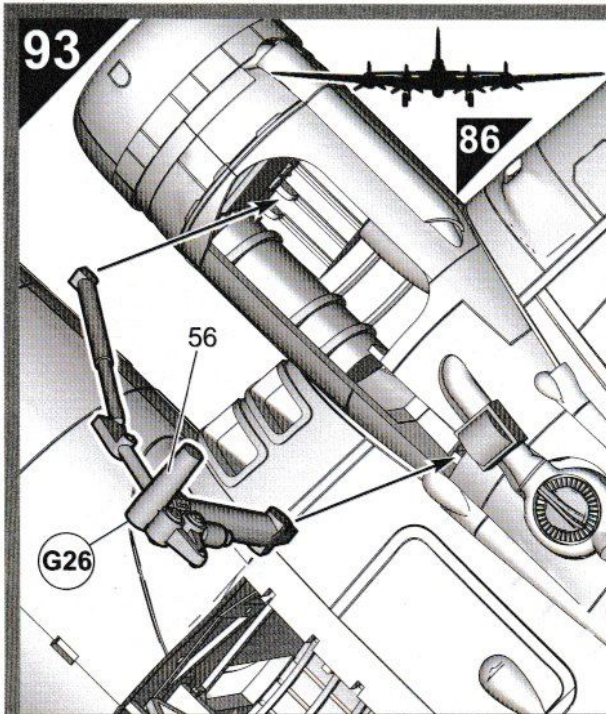

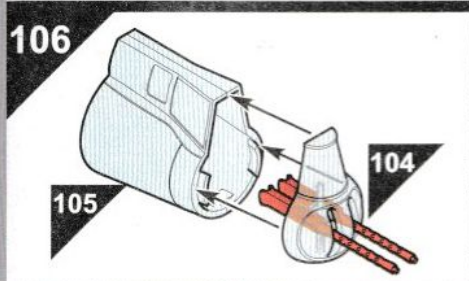
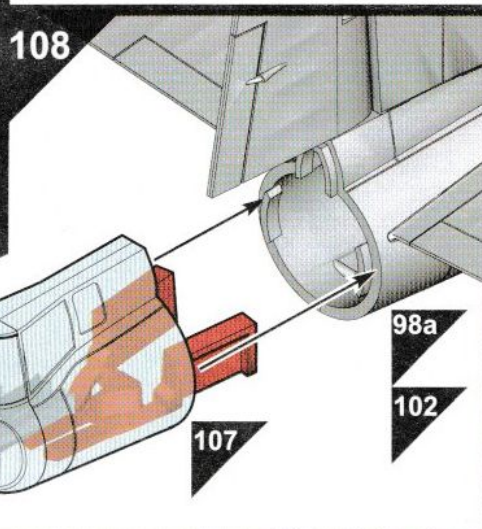
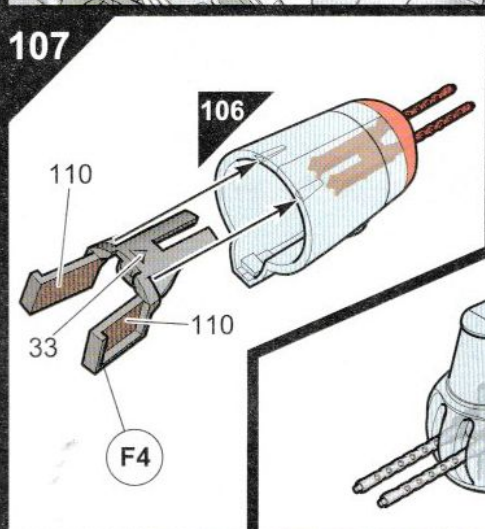
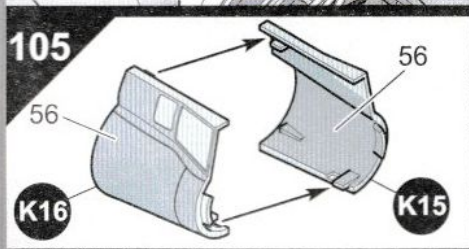
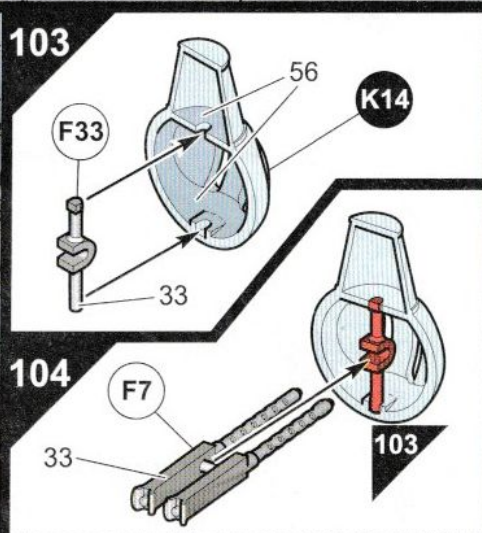
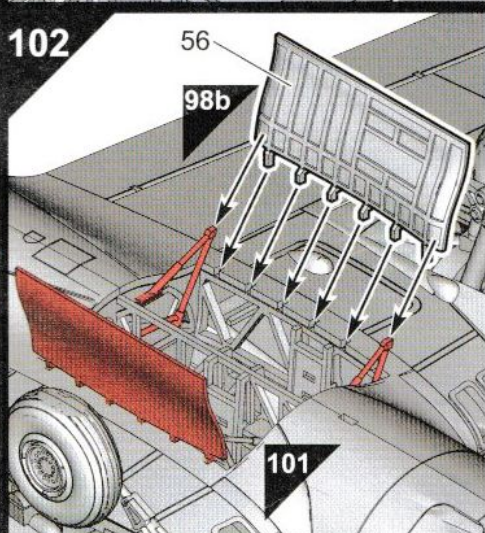
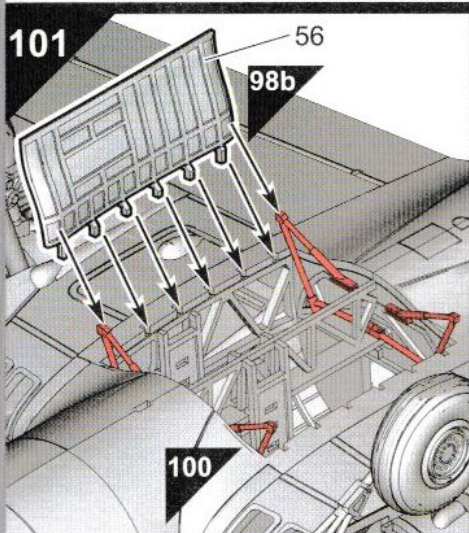
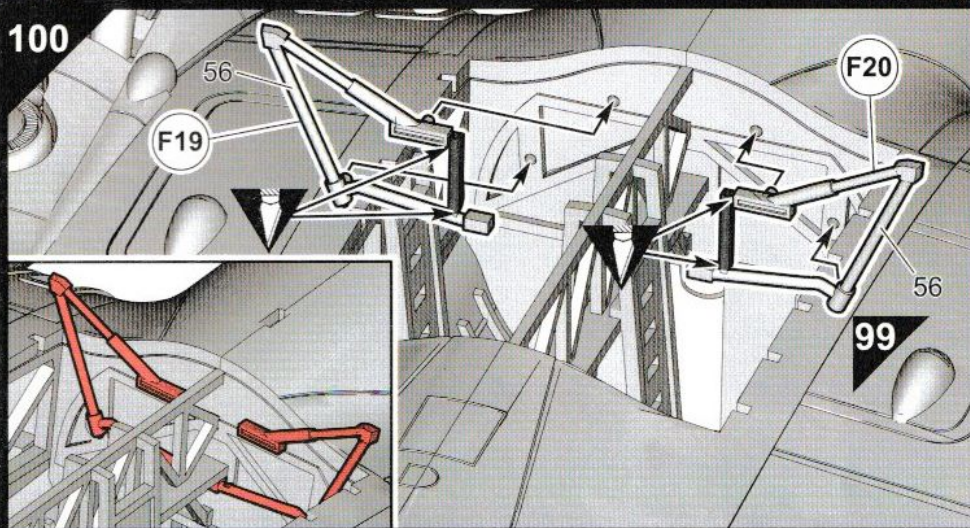
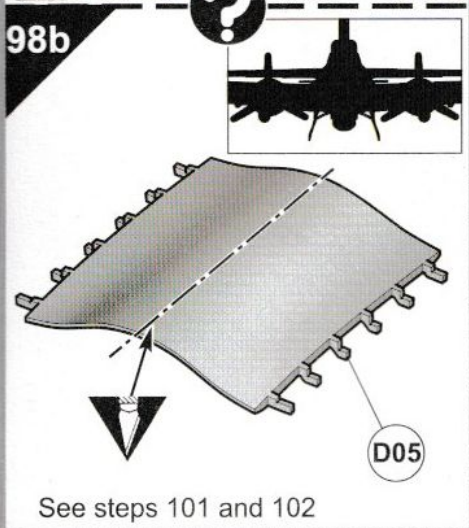
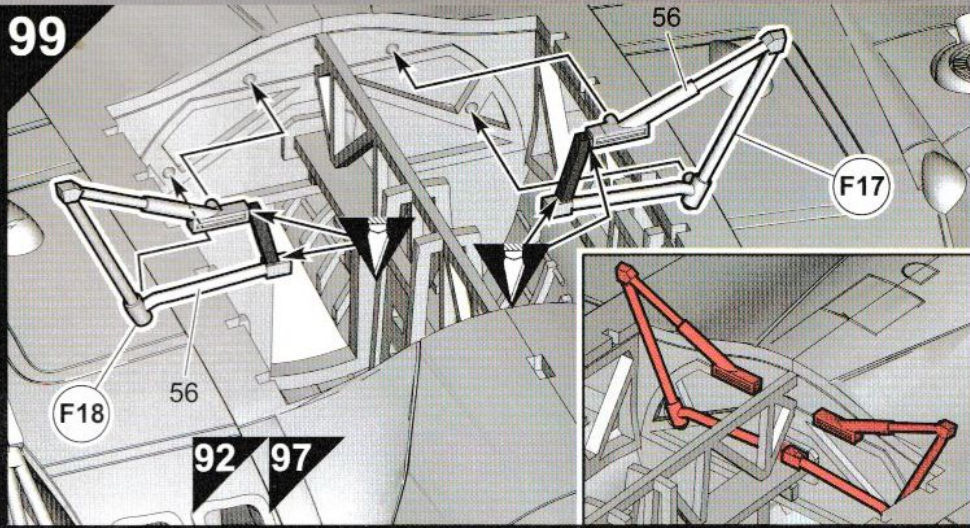
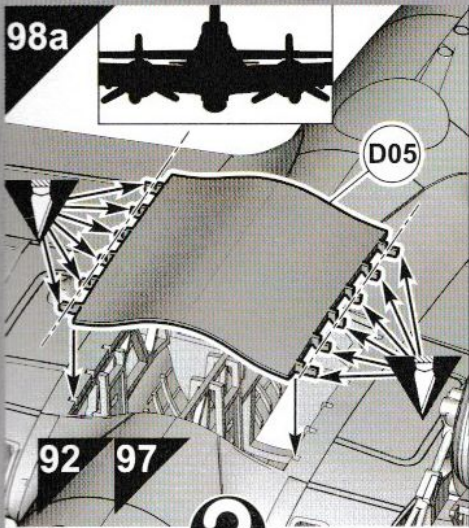

109

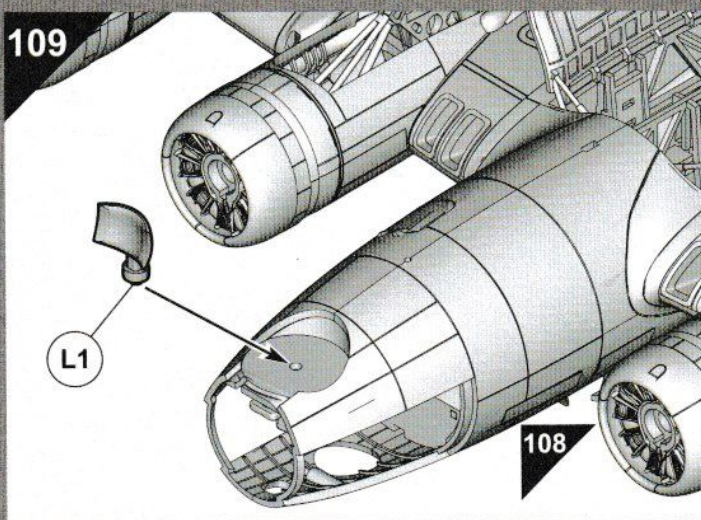

110

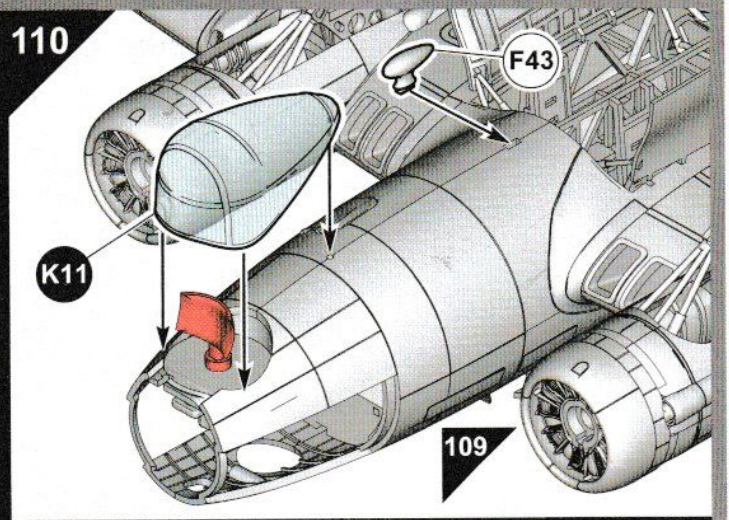

111

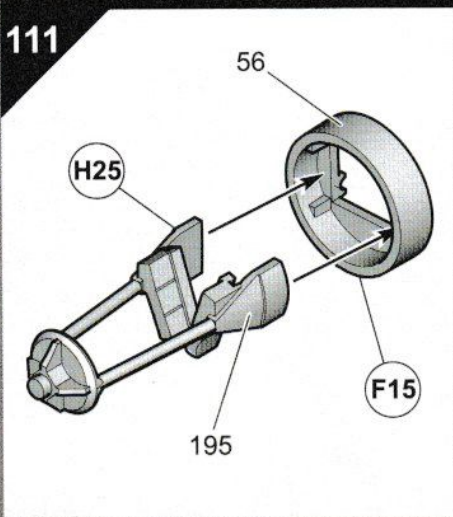

112

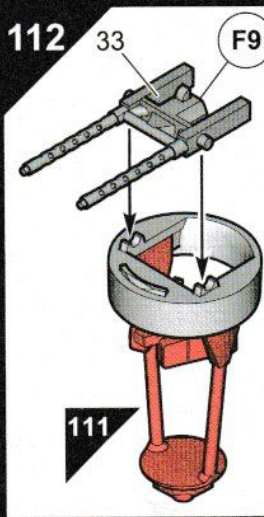

113

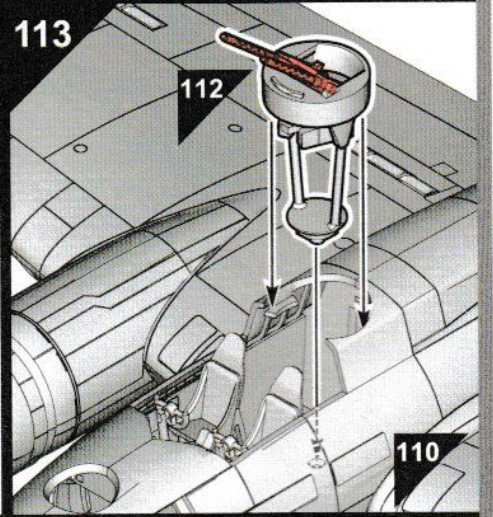

114

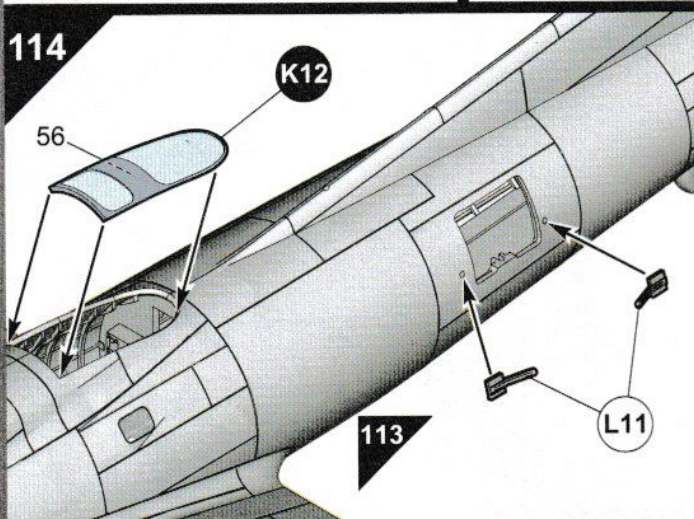

115

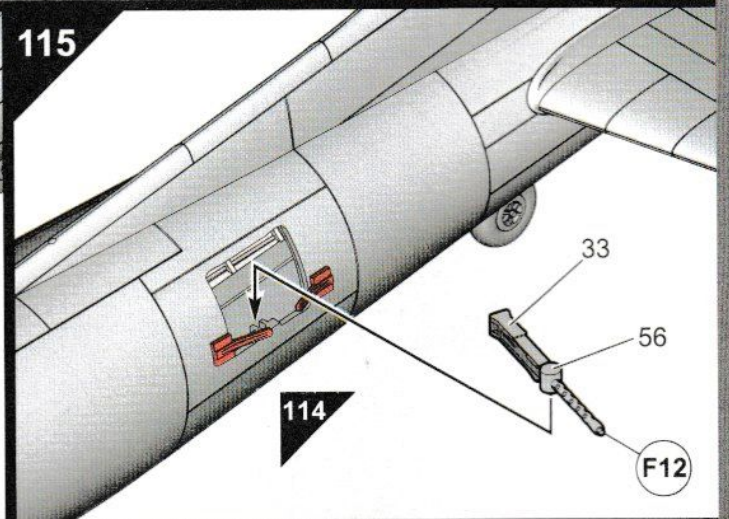

116

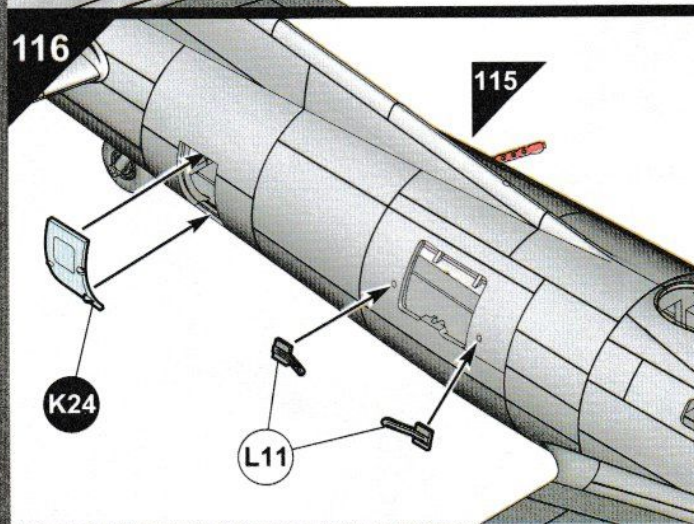

117

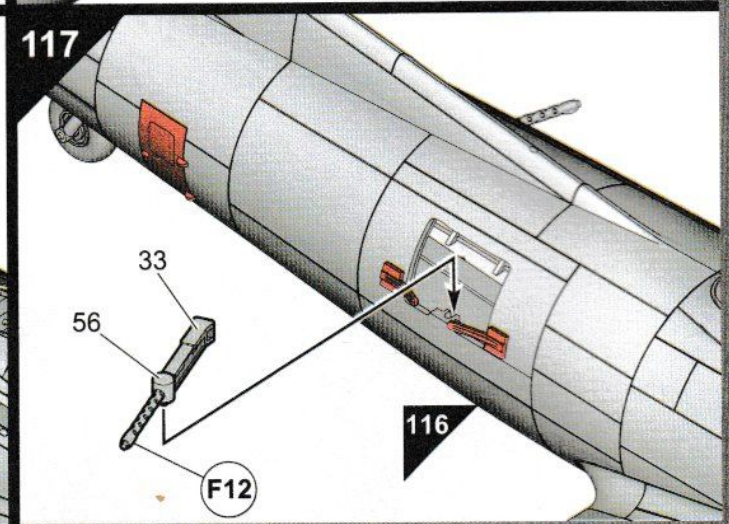

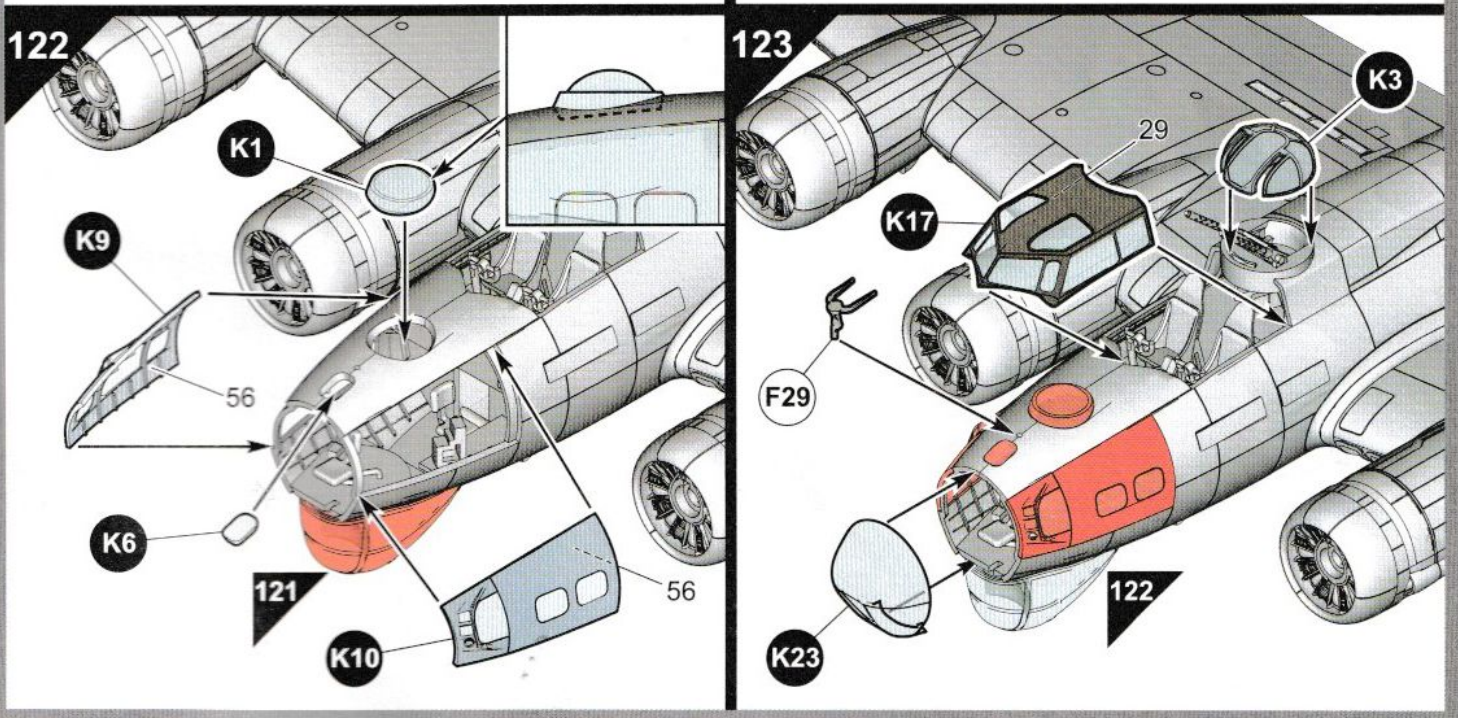
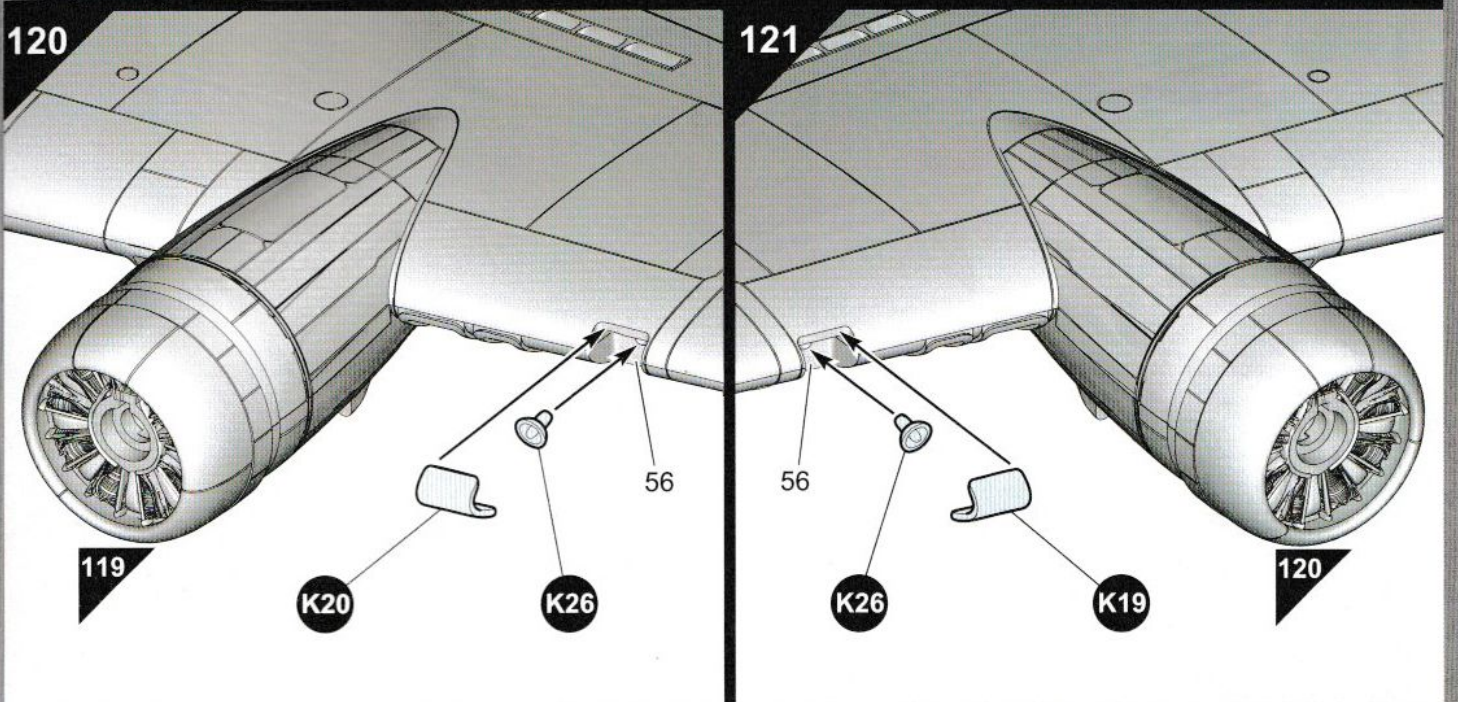
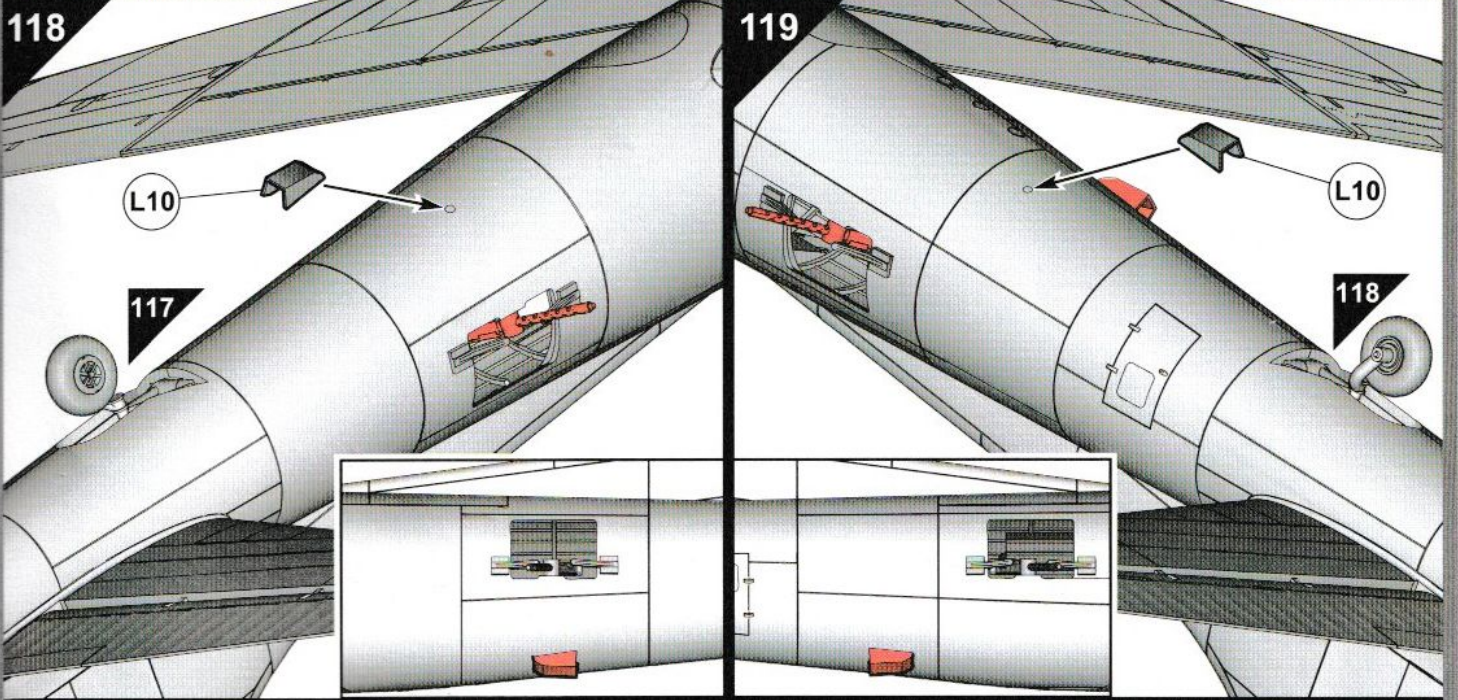

124

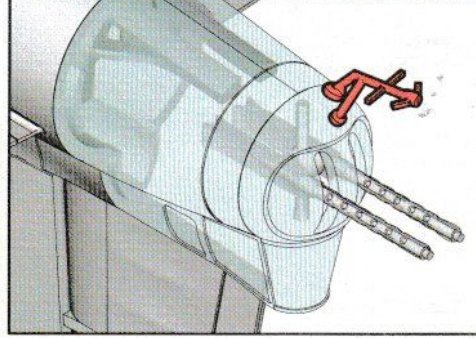
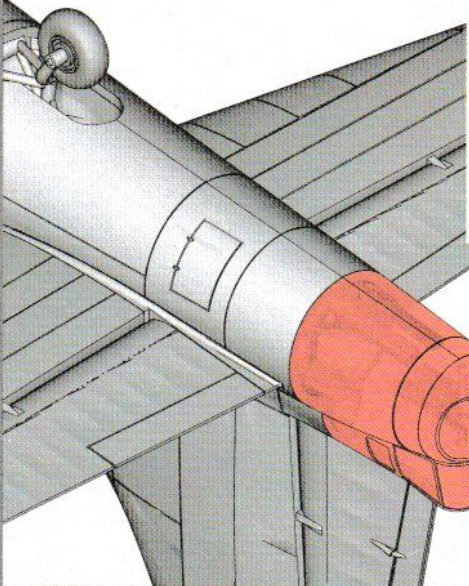

125

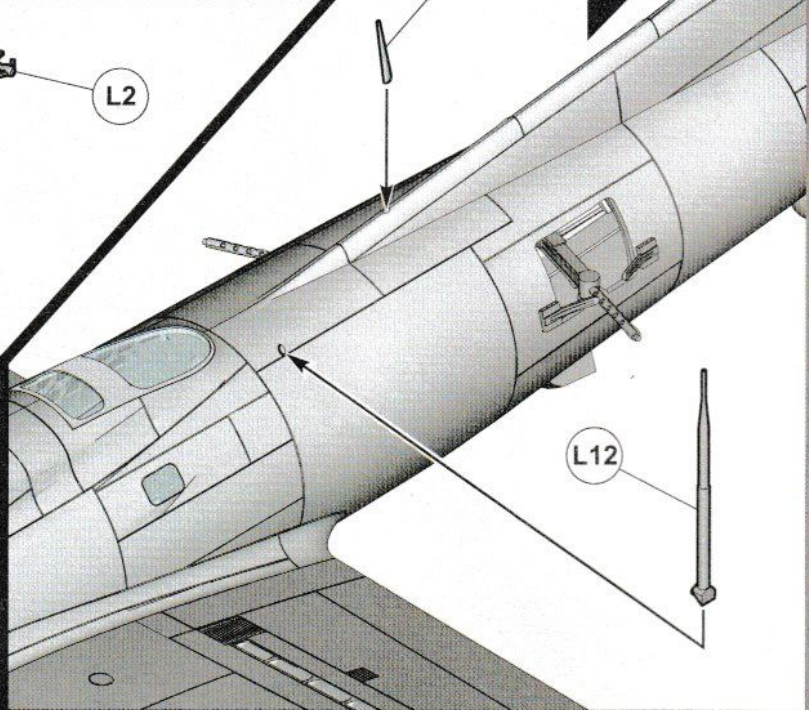

126

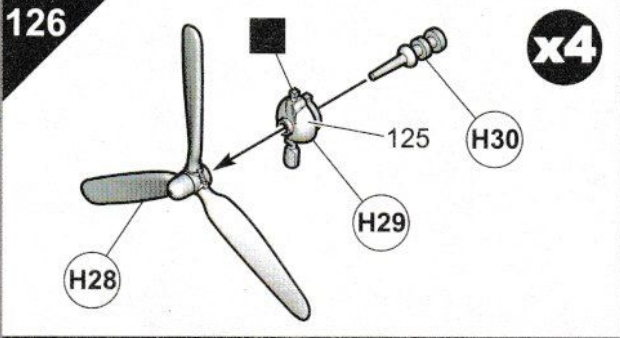

127

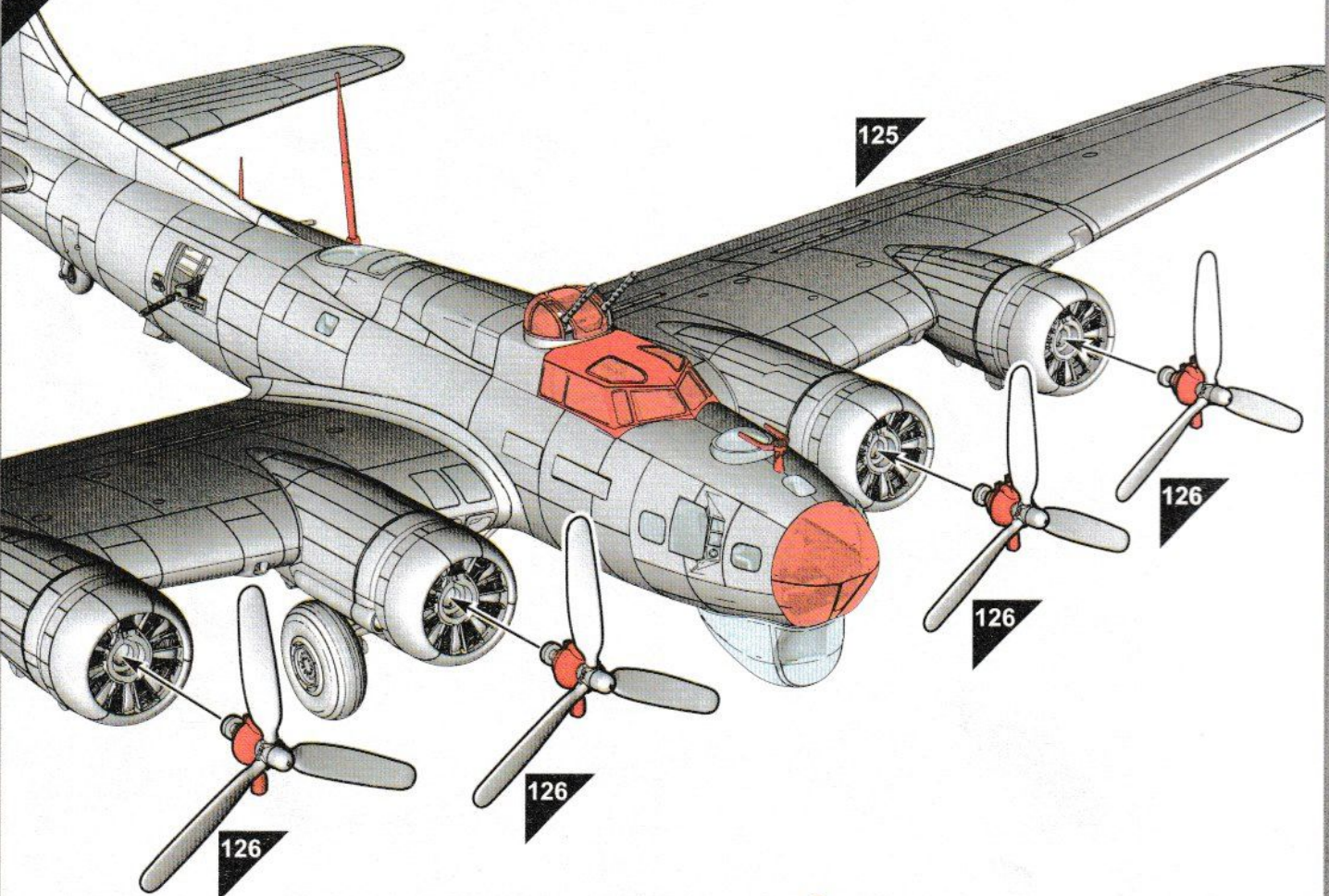

A Boeing Fortress
 "Take it Easy", No.214 (Federated Malay States) S
 Royal Air Force Sculthorpe and Royal Air F

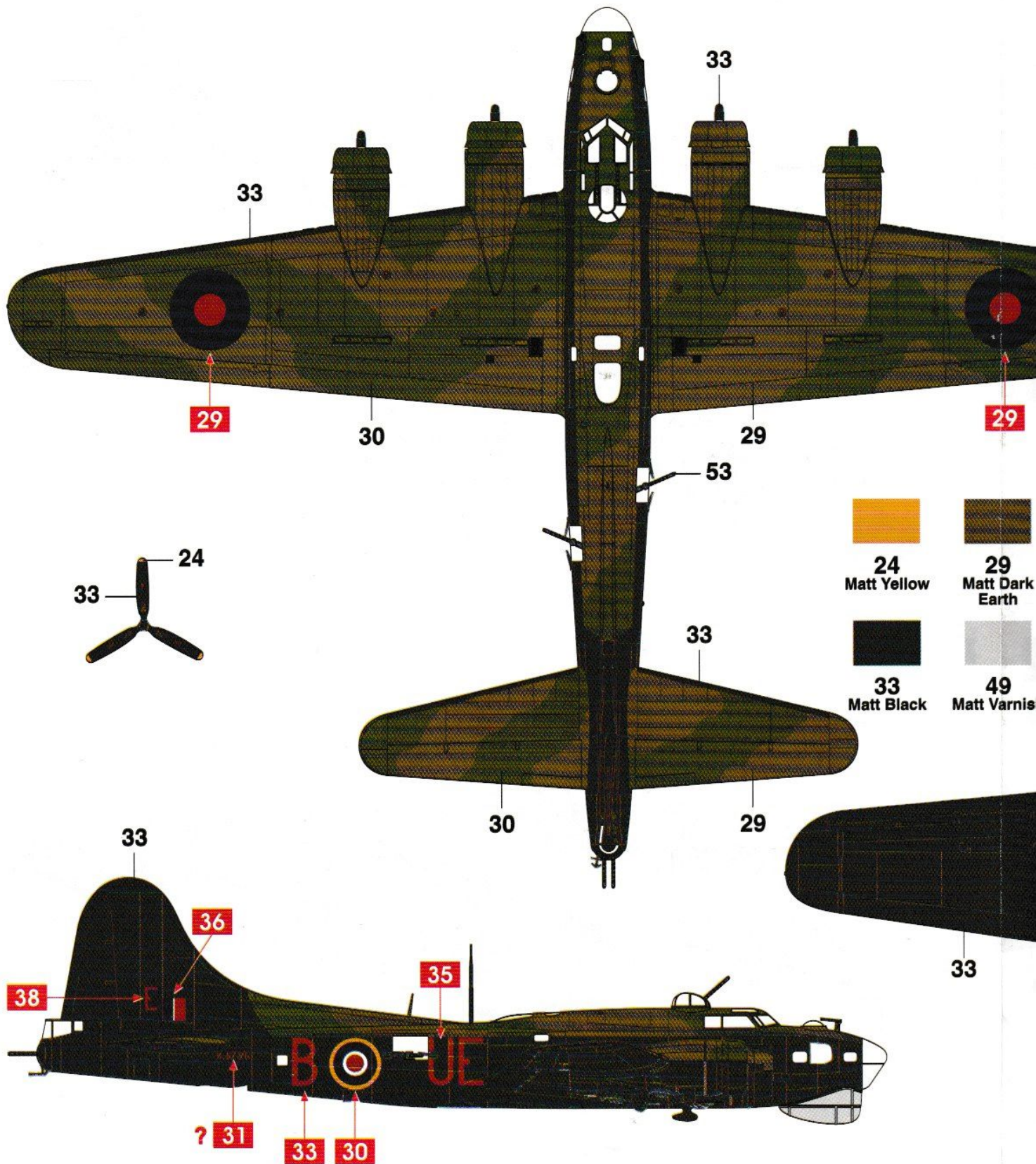

Bombardier Fortress Mk.III™

100 (Bomber Support) Squadron, No. 100 (Bomber Support) Group,
 Air Force Oulton, Norfolk, England, 1944.

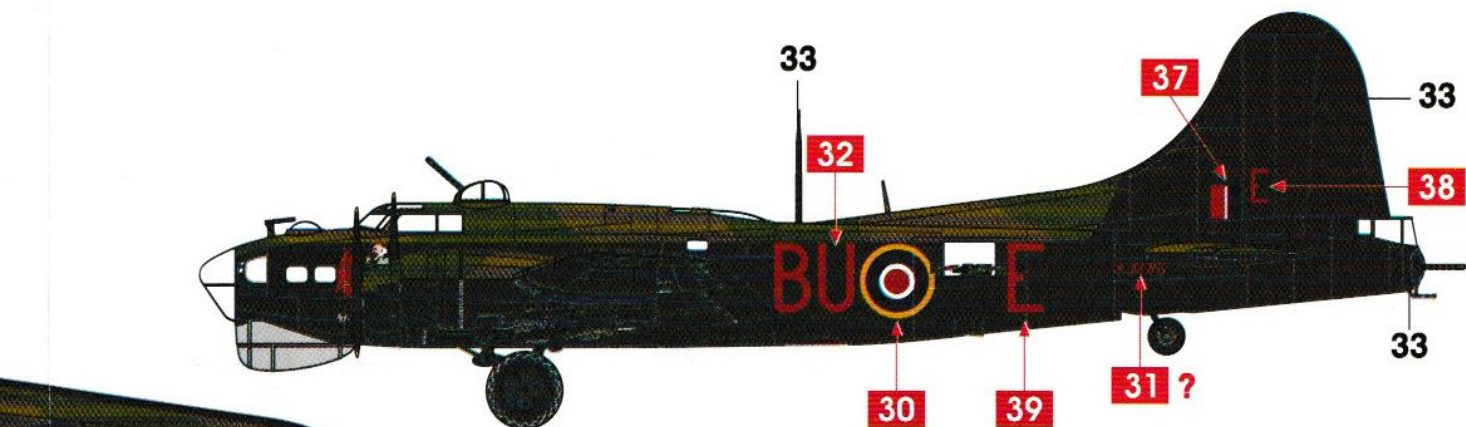

Note: Serial number for "Take it Easy" remains unknown, some sources quote it as being KJ177/G, but research is ongoing.



29



29
Matt Dark Earth

30
Matt Dark Green

49
Matt Varnish

53
Gun Metal



Paint clear radome with 49 matt varnish to mimic semi-opaque finish of original.

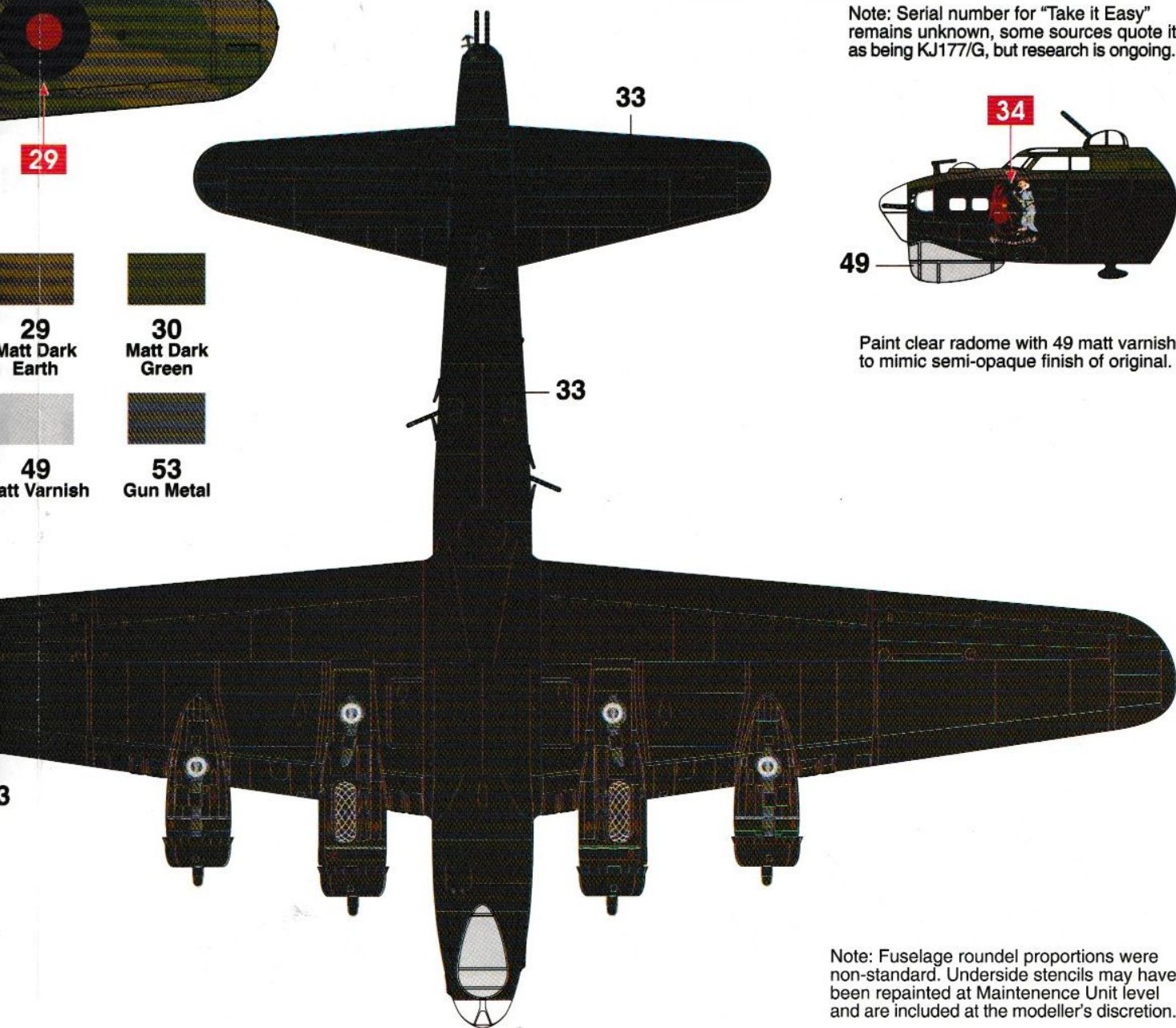

Note: Fuselage roundel proportions were non-standard. Underside stencils may have been repainted at Maintenance Unit level and are included at the modeller's discretion.

B Boeing Fortre

No.223 Squadron, No. 100 (Bomber Support) Group, Ro
Norfolk, Engla

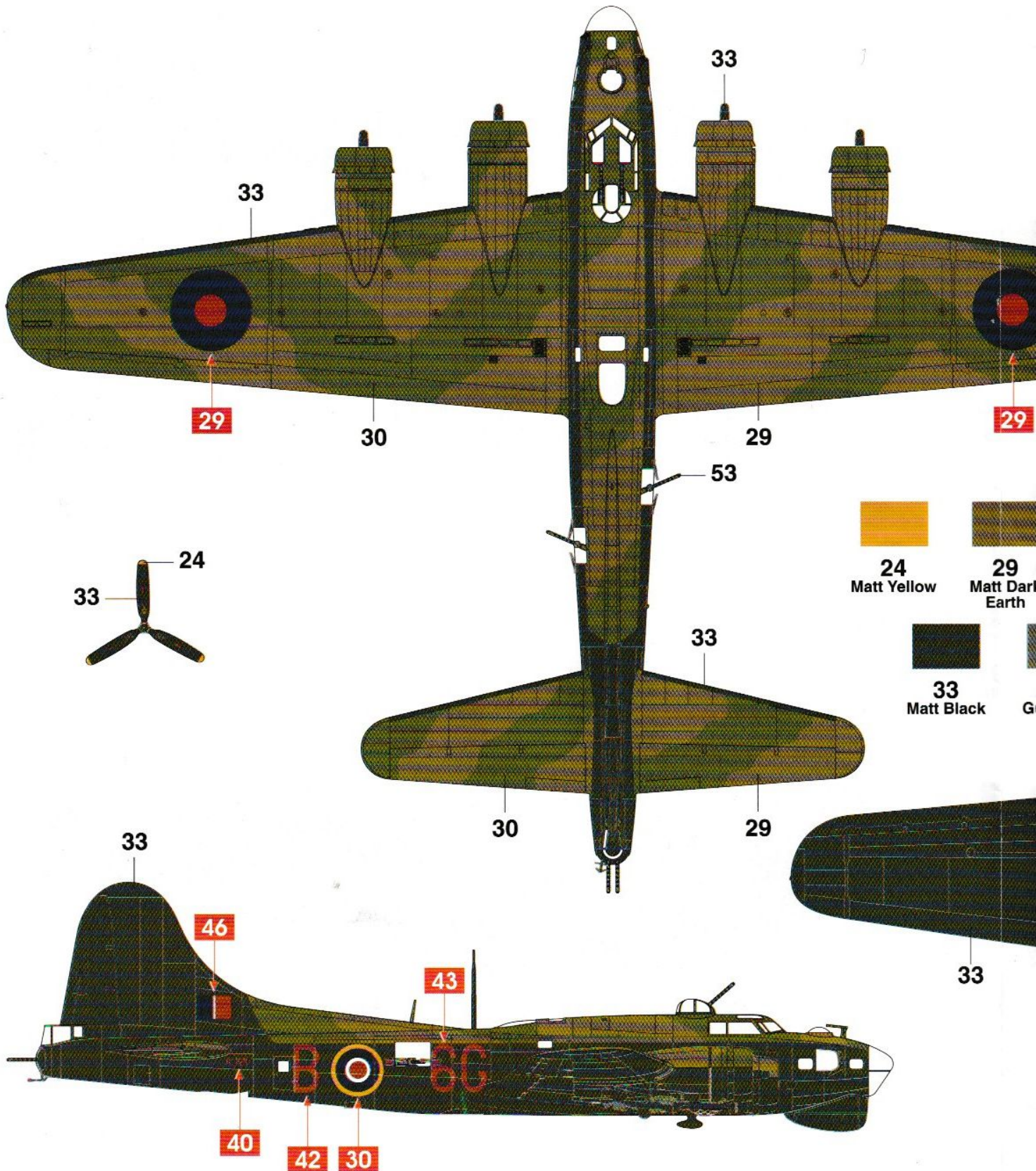

Bombardier B-24 Liberator Mk.III™

100 Squadron, Royal Air Force Sculthorpe and Royal Air Force Oulton, England, 1944.

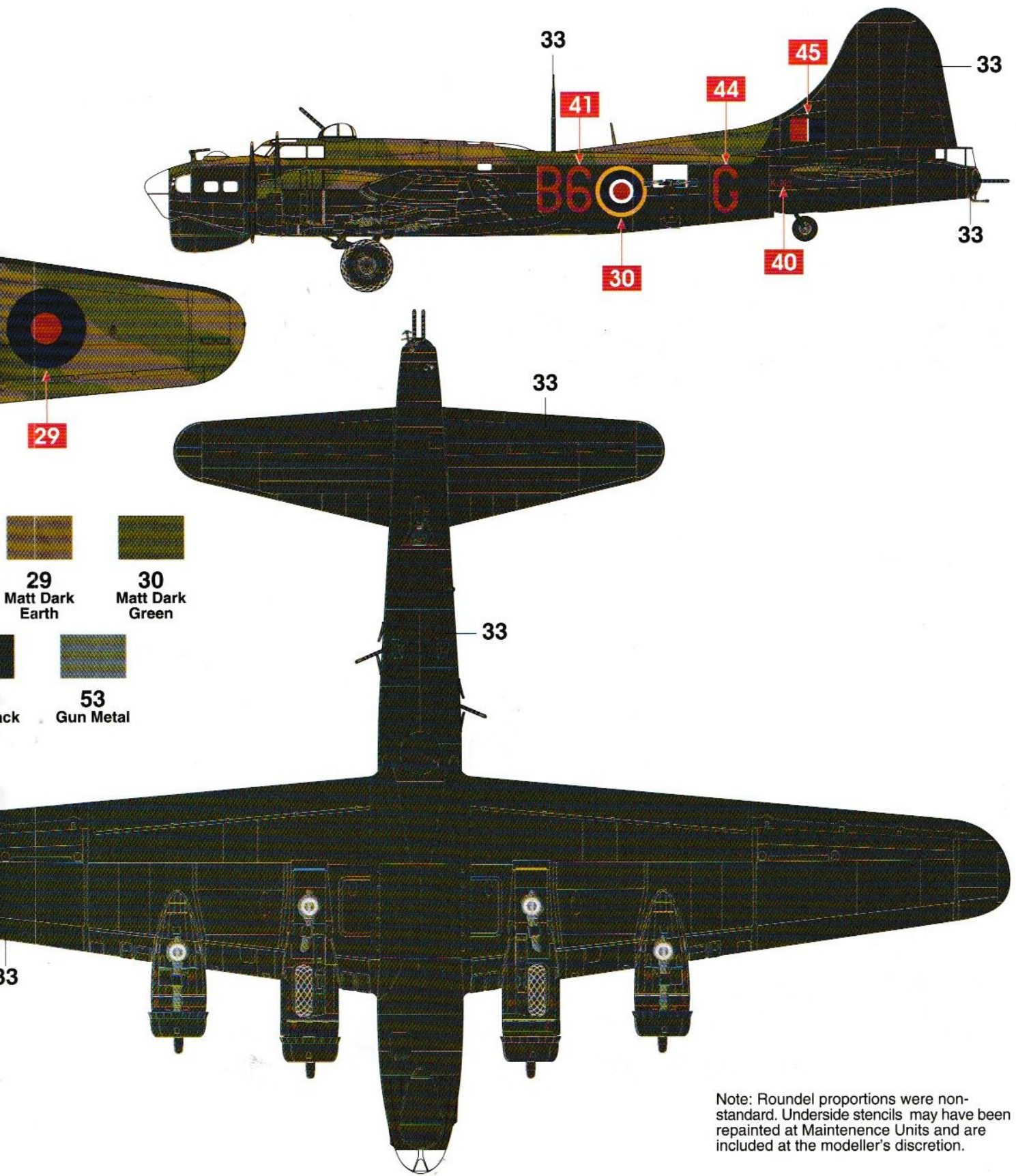

Note: Roundel proportions were non-standard. Underside stencils may have been repainted at Maintenance Units and are included at the modeller's discretion.

Boeing Fortress

Position of common

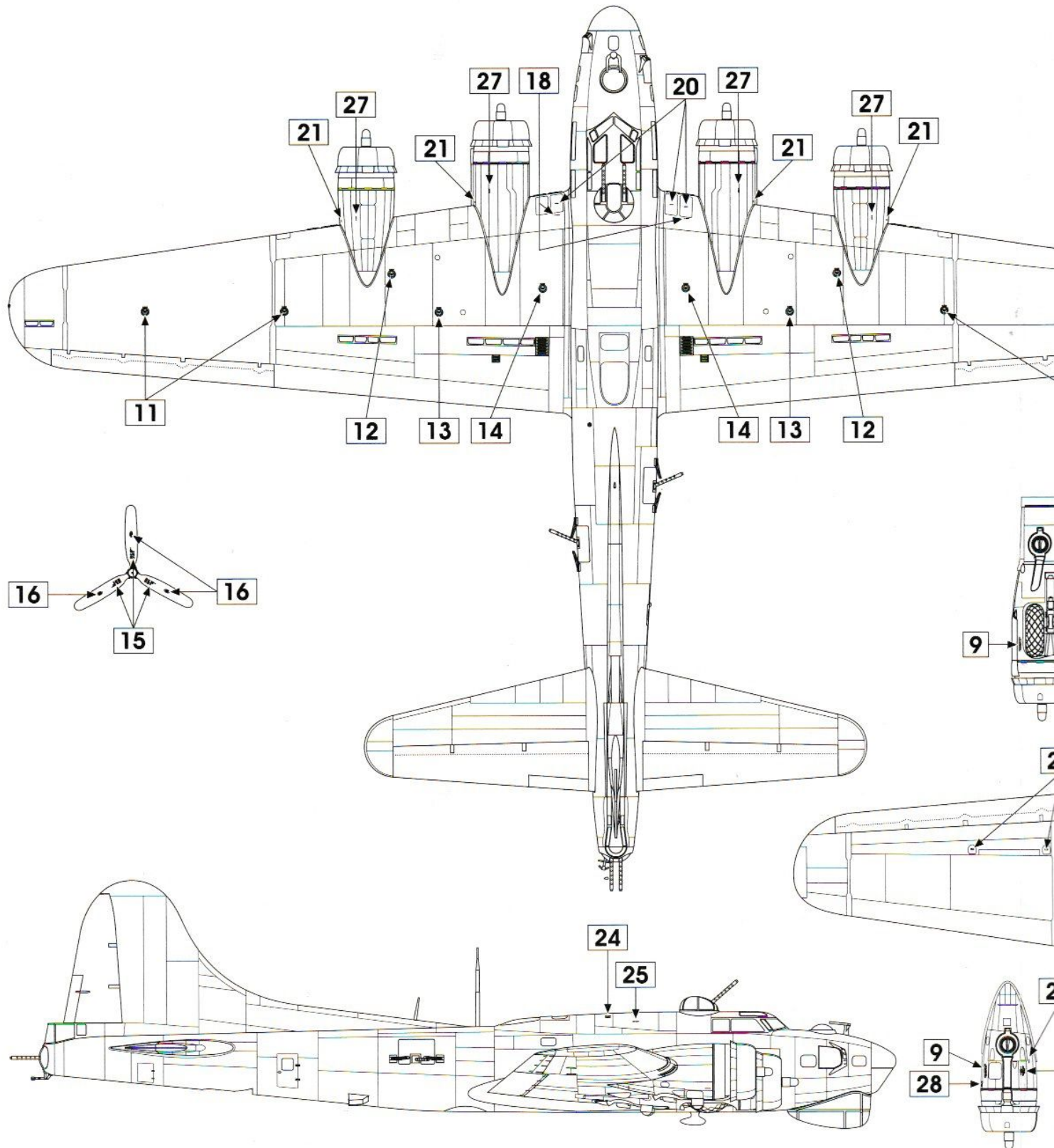

Fortress Mk.III™

Common stencil data

