



1:48 Boulton Paul Defiant NF.I

A05132 SCALE MODEL CONSTRUCTION KIT | Wingspan: 250mm Fuselage Length: 225mm | Two Decal Schemes Included

GB The Boulton-Paul Defiant holds a unique place in British aviation history as the only 'turret fighter' to enter service with the RAF. A contemporary of the only other turret fighter, Royal Navy's Blackburn Roc, the Defiant used the philosophy that a fighter aircraft, armed solely with a turret bristling with machine guns would be able to enter a bomber stream causing havoc and the turret would also enable it to defend itself from enemy fighters. However, despite the sleek lines of the aircraft and its powerful Merlin engine, the Defiant proved to be a failure in the role of daylight interceptor. During its first few engagements during the Battle of Britain in 1940, enemy pilots were taken by surprise and the Defiant fared well. But soon the Luftwaffe pilots worked out its weaknesses, especially the lack of forward firing guns which meant head-on attacks from enemy fighters were often fatal. The Defiant was soon relegated to night fighting duties where it fared better, before being eventually re-assigned to Air Sea Rescue work and training duties.

FR Le Boulton-Paul Defiant occupe une place unique dans l'histoire de l'aviation britannique en tant que seul avion de chasse équipé d'une tourelle en service au sein de la RAF. Contemporain de l'autre chasseur à tourelle, le Blackburn Roc de la Royal Navy, le Defiant était conçu selon l'idée qu'un chasseur, armé seulement d'une tourelle bourrée de mitrailleuses, était capable de pénétrer une escadrille de bombardiers pour y faire des ravages. La tourelle lui permettrait de se défendre contre les chasseurs ennemis. Néanmoins, malgré les lignes épurées de l'avion et son puissant moteur Merlin, le Defiant s'avéra être un échec dans le rôle d'intercepteur de jour. Il sortit vainqueur de ses premiers combats pendant la bataille d'Angleterre en 1940 car les pilotes allemands furent pris par surprise. Mais les pilotes de la Luftwaffe tirèrent bientôt parti de ses faiblesses, notamment à cause du manque d'armement sur l'avant et donc de sa grande vulnérabilité à l'attaque frontale des chasseurs ennemis. Peu après, le Defiant fut relégué avec succès à la chasse de nuit avant d'être réaffecté au sauvetage en mer et à l'entraînement.

DE Als einziges 'Kampfflugzeug mit Turm' der RAF ist die Boulton Paul Defiant in der britischen Luftfahrtgeschichte einzigartig. Als Zeitgenossin des einzigen anderen Kampfflugzeugs mit Turm, der Blackburn Roc der Royal Navy, stützte sich die Defiant auf die Philosophie, dass ein allein mit einem Turm voller Maschinengewehre bewaffnetes Kampfflugzeug in einen Bomberstrom eindringen und Chaos verursachen kann und der Turm es ihr zudem ermöglicht, sich gegen feindliche Kampfflugzeuge zu verteidigen. Trotz ihrer schnittigen Linienführung und ihrem kraftvollen Merlin-Triebwerk war die Defiant als Tagjäger ein Misserfolg. Bei ihren ersten Einsätzen während der Schlacht um England im Jahre 1940 wurden feindliche Piloten überrascht und behauptete sich die Defiant gut. Die Luftwaffe-Piloten identifizierten jedoch bald ihre Schwächen, insbesondere die fehlenden nach vorne feuenden Geschütze, weshalb Frontalangriffe durch feindliche Kampfflugzeuge oft tödlich waren. Bald danach flog die Defiant – mit besseren Ergebnissen – Nacht einsätze, bevor sie letztendlich für die Luft-See-Rettung und Ausbildung eingesetzt wurde.

ES El Boulton Paul Defiant ocupa un papel único en la historia de la aviación británica como único caza con torreta que entró en servicio en la RAF. Contemporáneo el otro único caza con torreta, el Blackburn Roc de la Royal Navy, el Defiant seguía la filosofía de que un avión de caza, armado solamente con una torreta repleta de ametralladoras podría entrar en una corriente de bombarderos y provocar importantes estragos. Además, la torreta le permitiría defenderse de los cazas enemigos. Sin embargo, a pesar de las estiladas líneas del aparato y de su potente motor Merlin, el Defiant resultó ser un fracaso en el papel de interceptor de día. En sus primeros combates durante la Batalla de Inglaterra en 1940, los pilotos enemigos se vieron sorprendidos y el Defiant logró varios éxitos. Pero los pilotos de la Luftwaffe no tardaron en descubrir sus puntos débiles, en especial la imposibilidad de disparar hacia adelante, lo que suponía que un ataque frontal de los cazas enemigos solía ser fatal. Muy pronto, el Defiant fue relegado a tareas nocturnas, en las que obtenía mejores resultados, para posteriormente ser asignado a trabajos de rescate aéreo y entrenamiento.

SE Boulton-Paul Defiant intar en unik plats i den britiska flyghistoriken eftersom det var det enda jaktplanet med kulsprutor som användes av RAF. I likhet med samtidens andra jaktplan av samma typ, den britiska flottans Blackburn Roc, byggde Defiant på principen att ett jaktplan som endast var bestyckat med ett vapentorn bestående av flera kulsprutor skulle kunna flyga in i en grupp av bombplan och orsaka kaos samtidigt som kulsprutorna försvarade mot fiendens jaktplan. Trots de smäckra skrovlinjerna och den kraftfulla Merlin-motorn visade sig dock Defiant vara undermålig som dagjaktplan. Under de första uppdragen vid Slaget om Storbritannien 1940 gjorde Defiant väl ifrån sig eftersom fiendepiloterna kunde tas med överraskning, men Luftwaffe lärde sig snart planetens svaga punkter, speciellt osäkerheten av framåtriktade kulsprutor som gjorde att fienden kunde attackera planet rakt framifrån, ofta med förödande resultat. Defiant relegerades inom kort till mer framgångsrika nattjaktuppdrag innan det intog rollen som sjöräddningsplan och skolplan.

Specification:

Speed: 304mph (489Km/h)

Range: 465m (749km)

Wingspan: 39 ft. 4 in (11.99 m)

Length: 35 ft. 4in (10.77 m)

Armament: 4 × 0.303 in (7.7mm) Browning machine guns in hydraulically powered dorsal turret.

Spécification:

Vitesse : 489 km/h

Autonomie : 749 km

Envergure : 11,99 m

Longueur : 10,77 m

Armement : quatre mitrailleuses Browning de 7,7 mm installées dans une tourelle dorsale à commande hydraulique.

Spezifikation:

Geschwindigkeit: 489 km/h

Reichweite: 749 km

Spannweite: 11,99 m

Länge: 10,77 m

Bewaffnung: 4 Browning-Maschinengewehre Kaliber 0,303 Zoll (7,7 mm) im hydraulisch angetriebenen Turm auf dem Rumpfücken.

Especificación:

Velocidad: 489 km/h

Autonomía: 749 km

Envergadura: 11,99 m

Longitud: 10,77 m

Armamento: 4 ametralladoras Browning de 7,7 mm en torreta dorsal con motores hidráulicos.

Specifikation:

Hastighet: 489 km/h

Räckvidd: 749 km

Spännvidd: 11,99 m

Längd: 10,77 m

Bestyckning: 4 st. 7,7 mm Browning-kulsprutor i ett hydrauliskt bakre torn.

Airfix would like to thank the RAF Museum, the Medway Air Preservation Society and especially Les Whitehouse and the Boulton Paul Association.

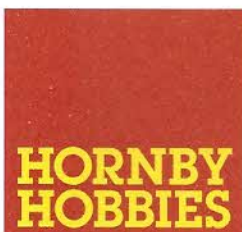

FOR BEST RESULTS:

Surfaces to be painted should be clean – before parts are removed from the sprue, wash in warm, soapy water, rinse and dry thoroughly. Stir paints thoroughly before use.

PLEASE NOTE:

Some parts in the kit may not be required to build the model specified.



ASSEMBLY INSTRUCTIONS

GB Study drawings and practice assembly before cementing parts together. Carefully scrape plating and paint from cementing surfaces. All parts are numbered. Paint small parts before assembly. To apply decals cut sheet as required, dip in warm water for a few seconds, slide off backing into position shown. Use in conjunction with box artwork. Not appropriate for children under 36 months of age, due to the presence of small detachable parts.

FR Étudier attentivement les dessins et simuler l'assemblage avant de coller les pièces. Gratter soigneusement tout revêtement ou peinture sur les surfaces à coller avant collage. Toutes les pièces sont numérotées. Peindre les petites pièces avant l'assemblage. Pour coller les décalques, découper le motif, le plonger quelques secondes dans de l'eau chaude puis le poser à l'endroit indiqué en décollant le support papier. Utiliser en même temps les illustrations sur la boîte. Ne convient pas à un enfant de moins de 36 mois – présence de petits éléments détachables.

DE Vor Verwendung des Klebers Zeichnungen studieren und Zusammenbau üben. Farbe und Plattierung vorsichtig von den Klebeflächen abkratzen. Alle Teile sind nummeriert. Vor Zusammenbau kleine Teile anmalen. Um die Abziehbilder aufzukleben, diese ausschneiden, kurz in warmes Wasser tauchen, dann abziehen und wie abgebildet aufkleben. In Verbindung mit Abbildungen auf Schachtel verwenden. Ungeeignet für Kinder unter 36 Monaten. Kleine Teilchen vorhanden die sich lösen können.

ES Estudiar los dibujos y practicar el montaje antes de pegar las piezas. Raspar cuidadosamente el plateado y la pintura en las superficies de contacto antes de pegar las piezas. Todas las piezas están numeradas. Es conveniente pintar las piezas pequeñas antes de su montaje. Para aplicar las calcomanías, cortar la hoja, sumergir en agua tibia durante unos segundos y deslizarlas en la posición debida. Ver ilustraciones en la caja. No conviene a un niño menor de 36 meses, contiene pequeñas piezas que pueden soltarse.

SE Studera bilderna noggrant och sätt ihop delarna innan du limmar ihop dem. Skrapa noggrant bort förtromning och färg från limmade delar. Alla delarna är numererade. Mala smadelarna före ihopsättning. Fastsättning av dekaler, klipp arket. Doppa i varmt vatten några sekunder, låt baksidan glida på plats som bilden visar. Används i samband med kartongens handlitografi. Rekommenderas ej för barn under 3 år. Innehåller löstagbara smadelar.

IT Studiare i disegni e praticare il montaggio prima di unire insieme i pezzi con l'adesivo. Raschiare attentamente le tracce di smalto e cromatura dalle superfici da unire con adesivo. Tutti i pezzi sono numerati. Colorare i pezzi di piccole dimensioni prima di montarli. Per applicare le decalcomanie, tagliare il foglio secondo il caso, immergere in acqua calda per alcuni secondi, quindi sfilare la decalcomania dalla carta di supporto e piazzarla nella posizione indicata. Usare in congiunzione con l'illustrazione sulla scatola. Non adatto ad un bambino di età inferiore ai 36 mesi dovuto alla presenza di piccoli elementi staccabili.

NL Tekeningen bestuderen en delen in elkaar zetten alvorens deze te lijmen. Metaalcoating en lak voorzichtig van lijmvlakken af schrapen. Alle delen zijn genummerd. Kleine delen vóór montage verven. Voor aanbrengen van stickers, gewenste stickers uit vel knippen, een paar seconden in warm water dompelen en dan van schutblad af op afgebeelde plaats schuiven. Hierbij afbeelding op doos raadplegen. Niet geschikt voor kinderen onder 3 jaar, omdat kleine deeltjes gemakkelijk kunnen losraken.

DK Tegningerne bør studeres, og man bør øve sig i monteringen, før delene limes sammen. Pladestykker og maling skal omhyggeligt fjernes fra kloebeoverfladerne. Alle dele er nummererede. Små dele skal males før monteringen. Overføringsbillederne anvendes ved at tilklippe arket efter behov. Og dyppe det i varmt vand i nogle få sekunder. Underlaget glides af og anbringes i den viste position. Påføres ifølge brugsanvisningerne på oesken. Ikke til børn under 3 år, forekomst af små løse elementer.

PT Estudar atentamente os desenhos e experimentar a montagem. Raspar cuidadosamente as superfícies de modo a eliminar pintura e revestimento antes de colar. Todas as peças estão numeradas. Pintar as pequenas peças antes de colar. Para aplicar as decalcomanias, cortar as folhas e mergulhar em água morna por alguns segundos, depois deslizar e aplicar no respectivo lugar, como indicado nas ilustrações na caixa. Não convém a uma criança de menos de 36 meses devido à presença de pequenos elementos destacáveis.

FI Tutustu piirroksiin ja harjoittele kokamista ennen kuin liimaat osat yhteen. Raaputa metallipäälyste ja maali varovasti pois liimattavilta pinoilta. Kaikki osat on numeroitu. Maalaa pienet osat ennen kokoamista. Siirtokuvien kiinnittämiseksi leikkaa ne arkista tarpeen mukaan. Kasta kuva lämpimään veteen muutaman sekunnin ajaksi, anna takapuolen liukua kovalle osoitettuun kohtaan. Käytetään yhdessä laatikon kuvituksen kanssa. Ei suositella alle kolmivuotiaalle lapsille. Pajon irrotettavia pikkuosia.

PL Przed przystąpieniem do sklejania przestuduj uważnie rysunki i przećwicz składanie części. Osłóźnie zeskrób ze sklejanych powierzchni powłokę i farbę. Wszystkie części są ponumerowane. Drobne części pomaluj przed ich złożeniem. Celem przeniesienia odbitki wytnij ją z arkusza, zanurz na kilka sekund w letniej wodzie i zsuń z podłoża na wymagane miejsce. Używaj w połączeniu ze wzorami na pudełku. W związku z obecnością wielu drobnych, rozbiernych części, nie stosowne dla dzieci poniżej 3 lat.

GR Μελετήστε προσεκτικά τα σχέδια και συναρμολογήστε για πρώτη φορά τα κομμάτια χωρίς να τα συγκολλήσετε. Αφαιρέστε επιμελώς τη μεταλλική μπογιά και την πλαστική βαφή από τις επιφάνειες τις οποίες θα συγκολλήσετε ζυγώντας τις προσεκτικά. Όλα τα κομμάτια είναι αριθμημένα. Χρωματίστε τα μικρά κομμάτια πριν από τη συναρμολόγηση. Για να κολλήσετε τις χαλκομανίες, κόψτε γύρω από το σχέδιο όπως απαιτείται, βυθίστε το μερικά δευτερόλεπτα σε χλιαρό νερό και μετά τοποθετήστε το στη θέση που υποδεικνύεται, αφαιρώντας τη μεμβράνη που το καλύπτει. Λάβετε υπόψη σας ταυτόχρονα την εικονογράφηση του κουτιού. Ακατάλληλο για παιδιά ηλικίας κάτω των 36 μηνών λόγω ύπαρξης μικρών κομματιών που αποσπώνται.

ASSEMBLY ICON INSTRUCTIONS

<p>Assembly phase Phase de montage Montagephase Fase de montaje Montingfasen Fase di montaggio Montagefase Fase de montagem Monteringsfase Kokoamisvaihe Faza składowania Φάση συναρμολόγησης</p> 	<p>Cement Coller Kleben Pegar Limma Incollare Lijmen Colar Klaebes Liimaa Kleić Συγκολλήστε</p> 	<p>Do not cement together No pas coller Nicht kleben Niet lijmen Não colar Skal ikke klaebes Älä liimaa Nie kleić Μη συγκολλήσετε</p> 	<p>Indicates final location Indique l'emplacement final Zeigt Endposition Indica la ubicación definitiva Anger slutmonteringsplats Sede di montaggio finale Geeft uiteindelijke locatie aan Indica localização final Viser endelig placering Osoittaa lopullisen sijainnin Oznacza miejsce docelowe Υποδεικνύει τελική τοποθεσία</p> 	<p>Alternative part(s) provided Autre(s) pièce(s) fournie(s) Ersatzteil(e) mitgeliefert Se incluye(n) pieza(s) alternativa(s) Alternativ(a) del(ar) ingår Uno o più componenti alternativi forniti Alternatieve onderdelen meegeleverd Peça(s) alternativa(s) fornecida(s) Alternativ(e) del(e) medfølger Valitohi toiset osat pakkauskassessa Dostępne części zamienne Παρέχονται εναλλακτικά κομμάτια</p> 	<p>Repeat this operation Répéter l'opération Vorgang wiederholen Repitir la operación Upprepa åtgärden Ripetere l'operazione De verrichting herhalen Repitir a operação Manövrer gentages Toista toimintapide Powtórzyc operację Επαναλάβετε τη διαδικασία</p> 	
<p>Decals Décalcomanies Abziehbild Calcomanías Dekaler Decalcomanie Stickers Decalomania Billedoverføring Siirtokuvat Kalkomanie Χαλκομανίες</p> 	<p>Crystal part Pièce cristal Kristallteil Pieza de cristal Kristalidel Pezzo cristallo Kristallen onderdeel Peça de cristal Kryсталлыкке Kryształowa Część kryształowa Κομμάτι κρυστάλλου</p> 	<p>Weight Lesler Beschweren Lastrar Belasta Aoplicare un peso Verzwaren Lastrar Påfør vægt Aseta vastapaino Obciążyć balastem Επιθέστε βάρος</p> 	<p>Remove by filing Enlever avec une lime Abfeilen Eliminar con lima Ta bort genom att fila Rimuovere con la lima Verwijderen door afvlijen Fjern ved at file væk Poista viilaamalla Usunąć przy użyciu pilnika Αφαιρέστε λιπαρώντας με λίμα</p> 	<p>Drill or pierce Percer Durchbohren Perforar Borra Trapanare o forare Boren of doorboren Furar Gennembor Poraa tai puhkaise Wywierć lub przedziurawić Τρυπήστε</p> 	<p>Cut Découper Schneiden Cortar Skär Tagliare Snijden Cortar Skär Leikkaa Przeciąć Κόψτε</p> 	<p>Humbrol paint number No peinture Humbrol Humbrol-Farbnummer No de pintura Humbrol Humbrol färg nummer No vemise Humbrol Humbrol varfnummer No de pintura Humbrol Humbrol-malingsnummer Humbrol-maalin numero Nr farby Humbrol Νομόερο χρώματος Humbrol</p> 

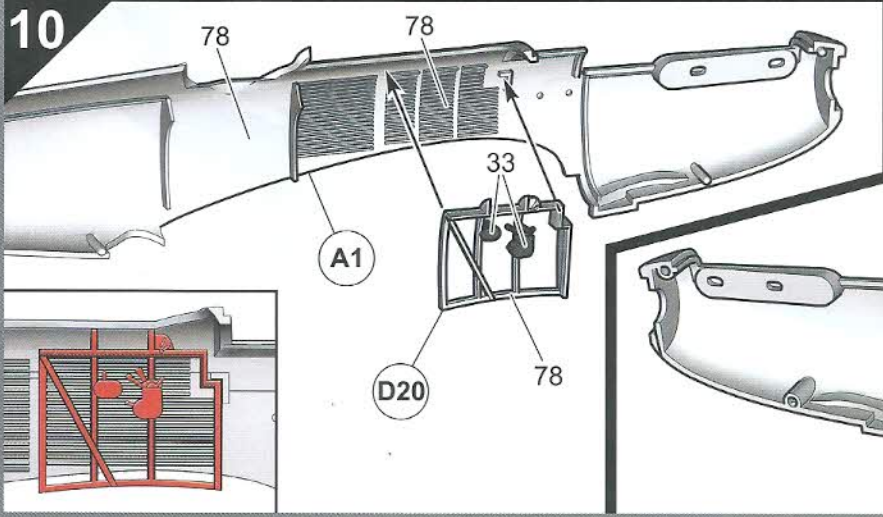
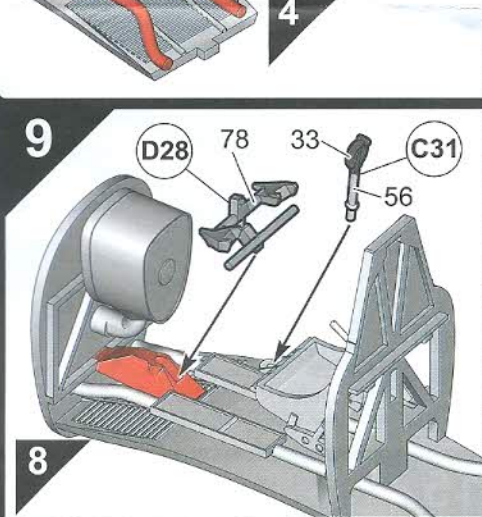
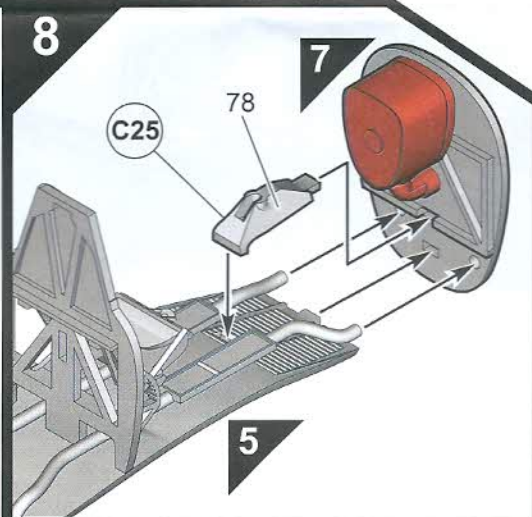
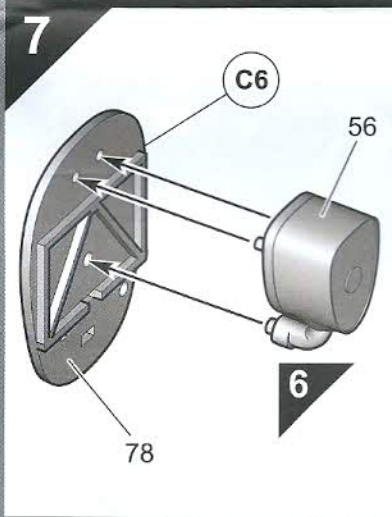
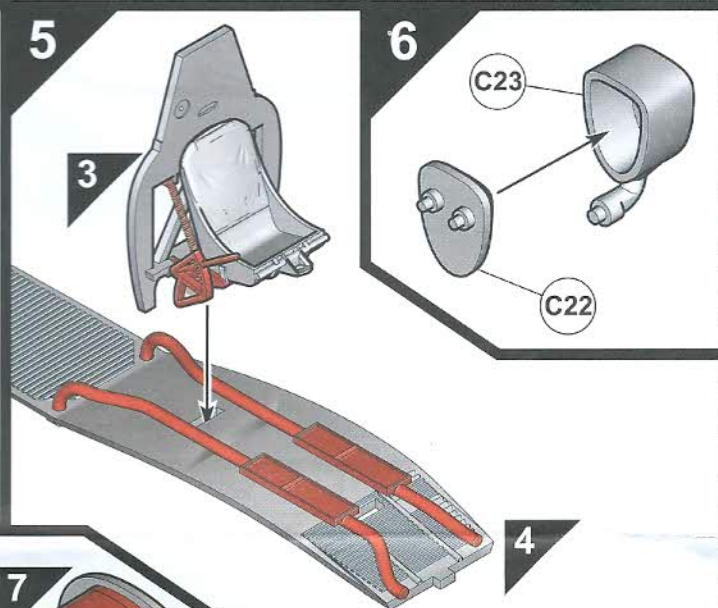
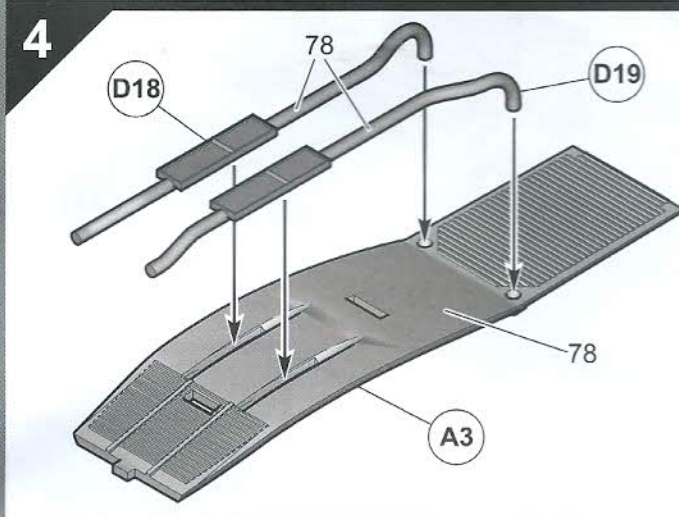
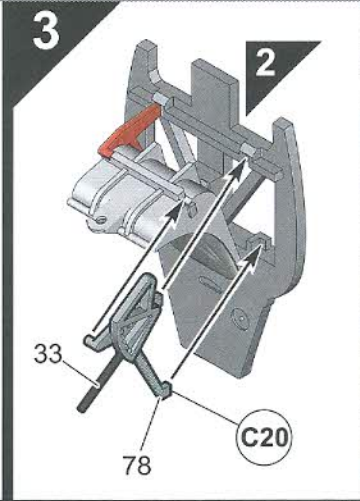
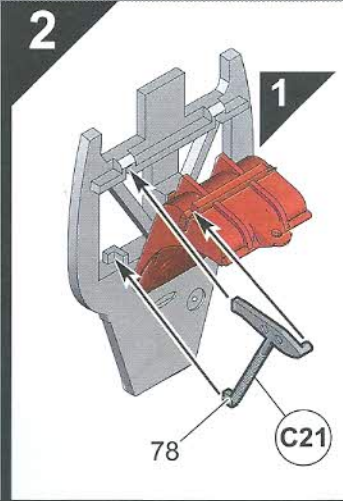
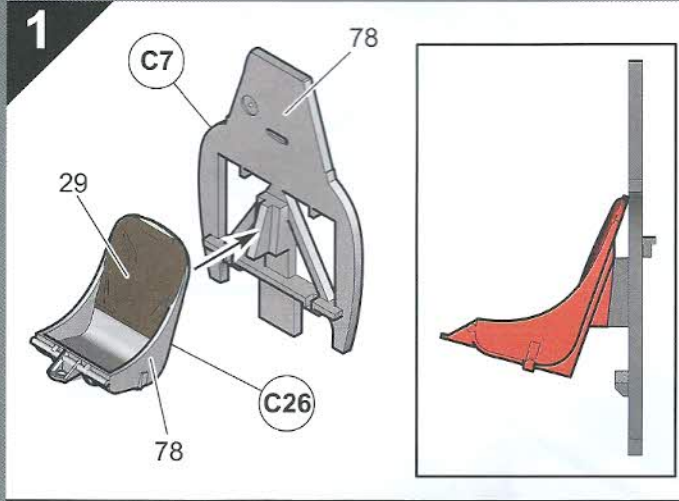

12

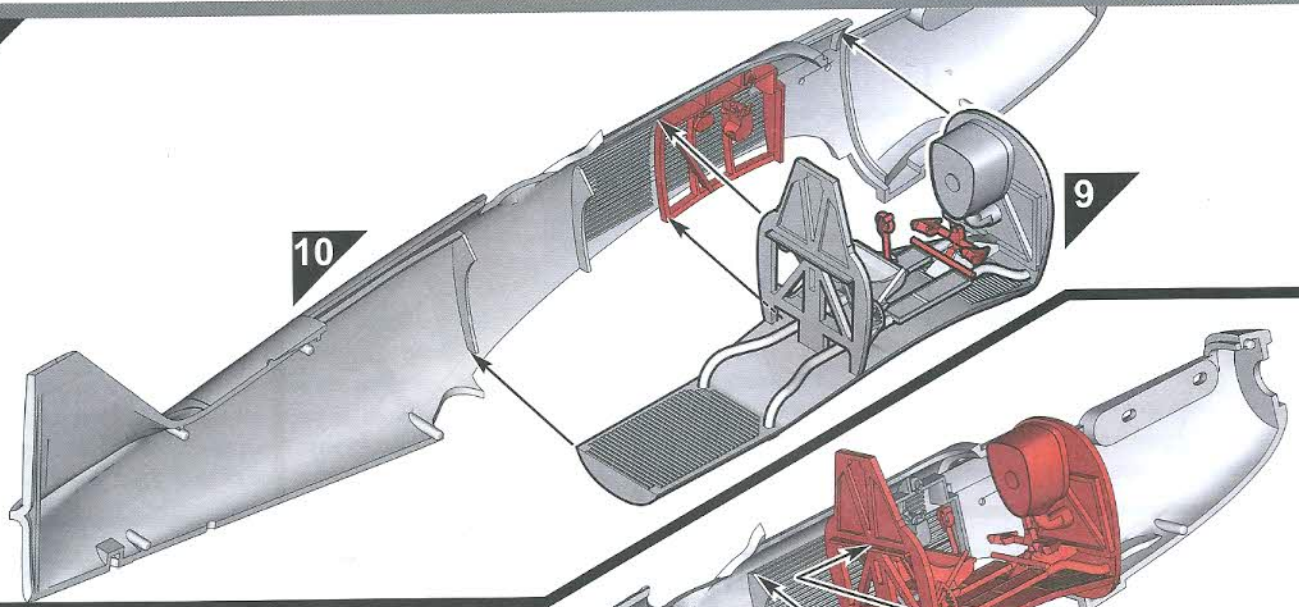

13

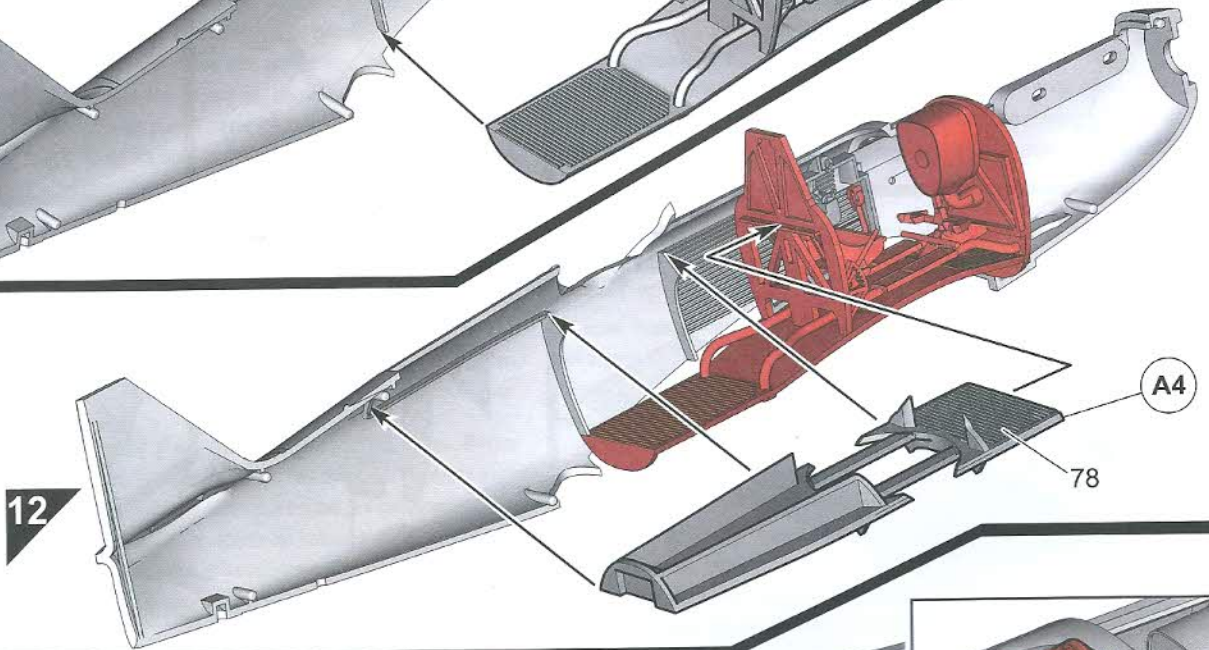

14

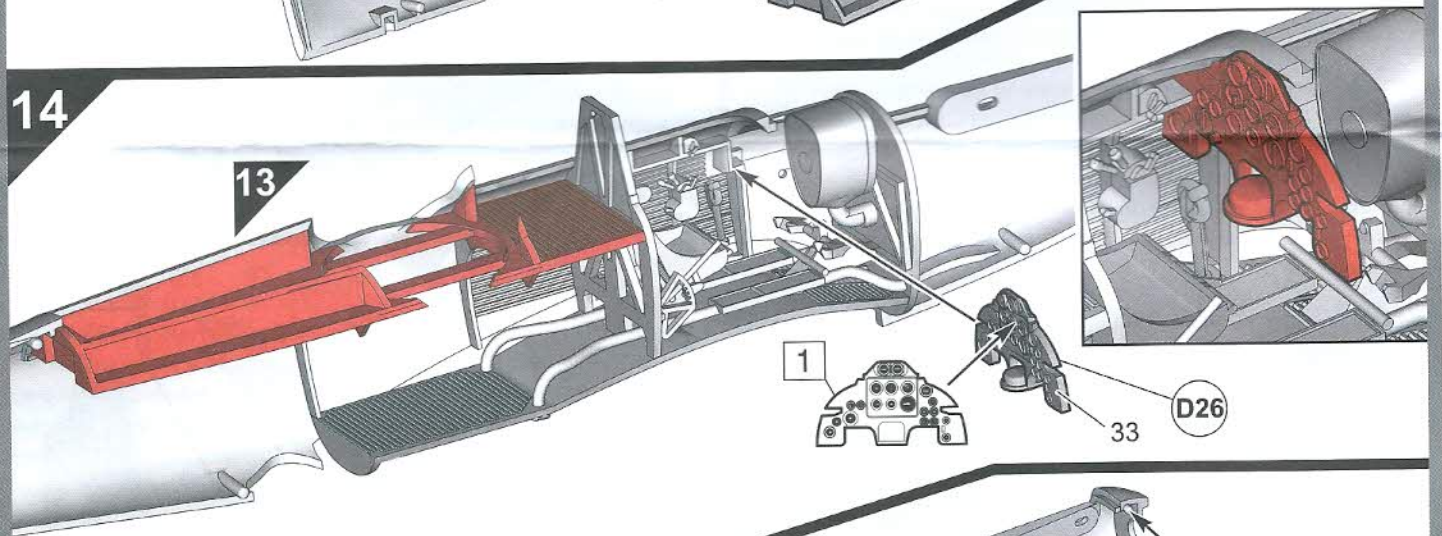

15

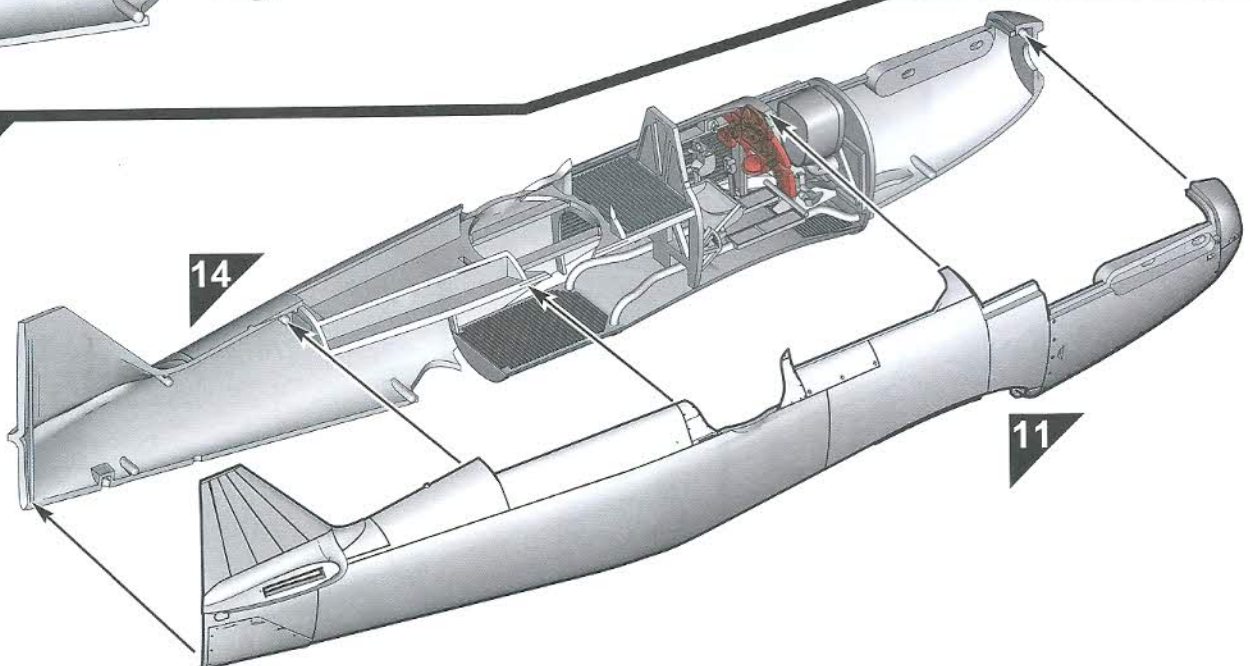

16

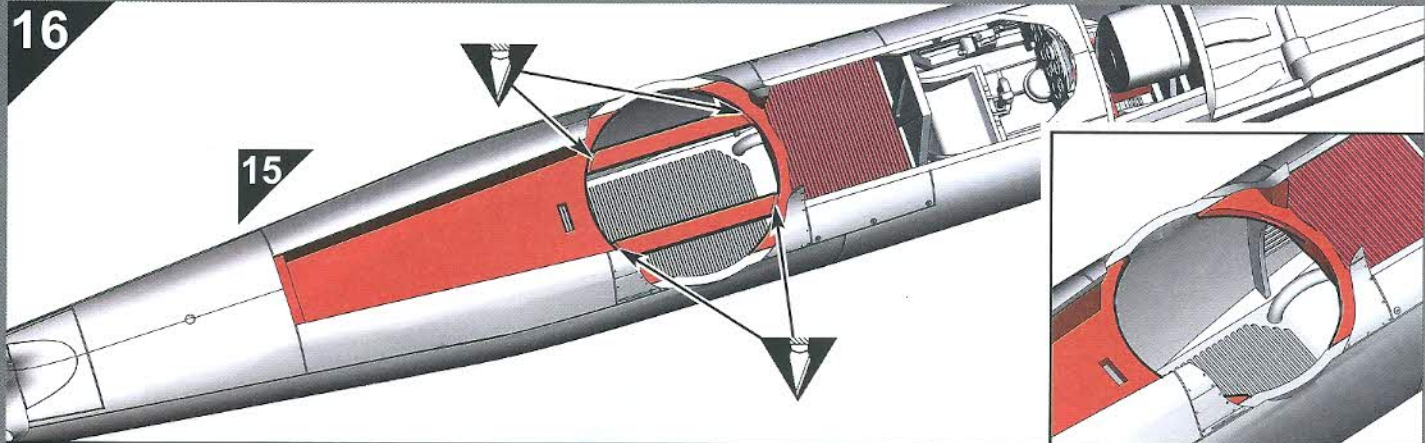

15

17

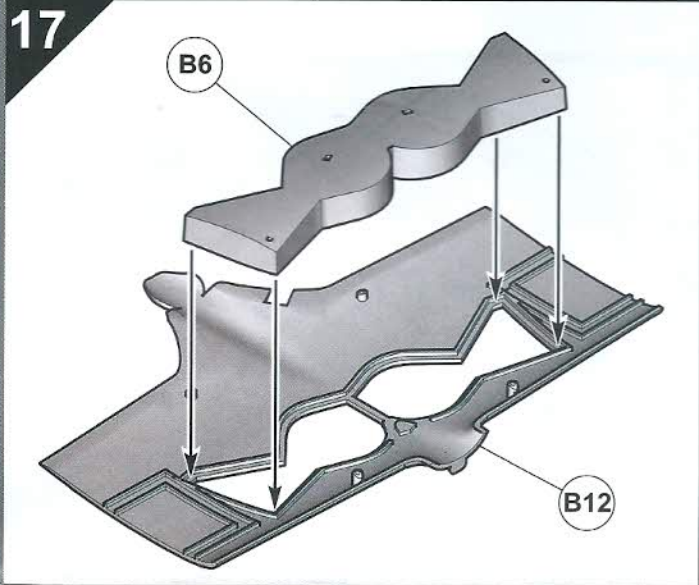

B6

B12

18

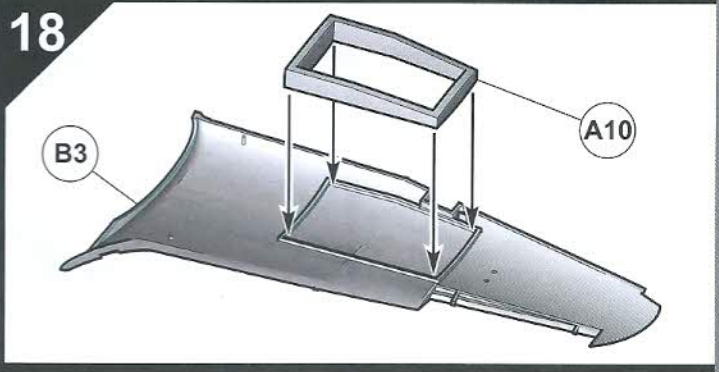

B3

A10

19

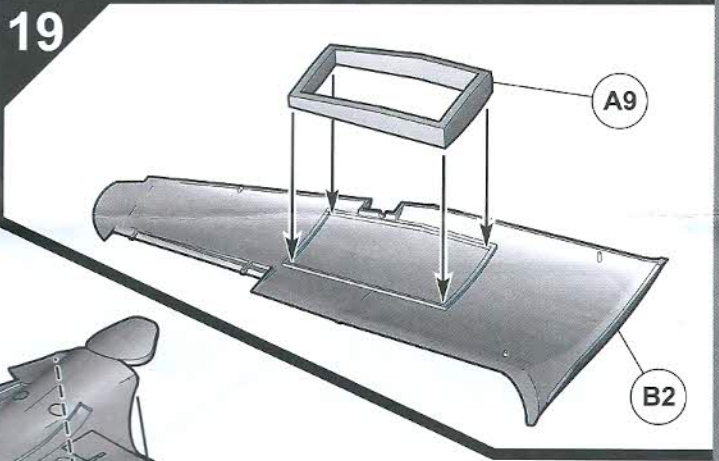

A9

B2

20

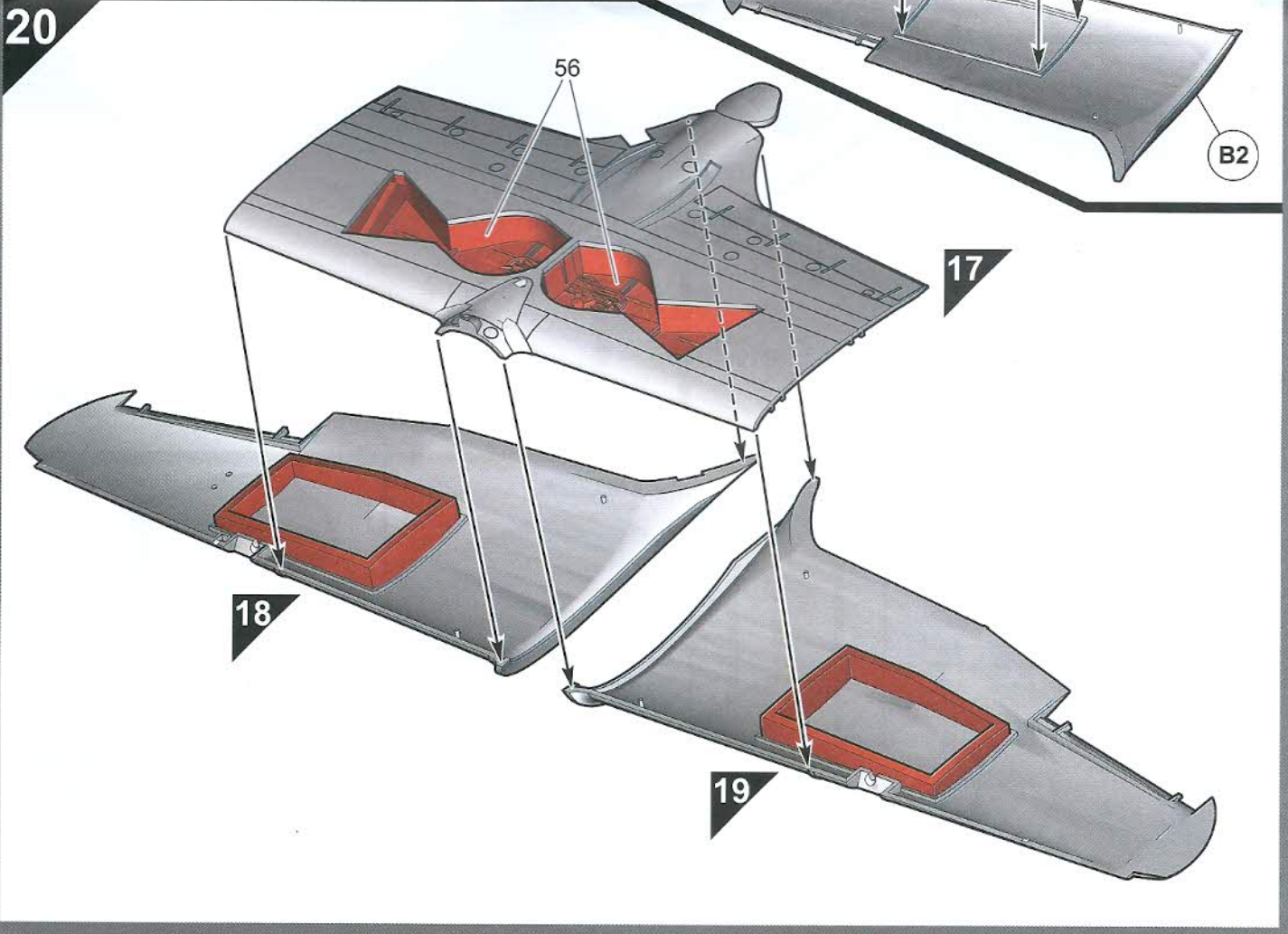

56

17

18

19

21

A12

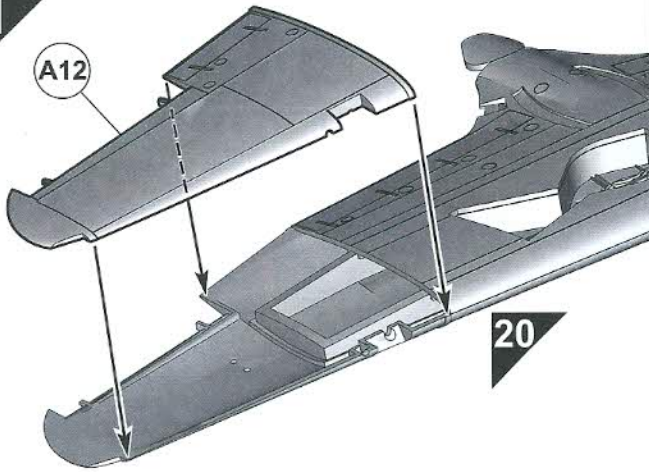

22

A11

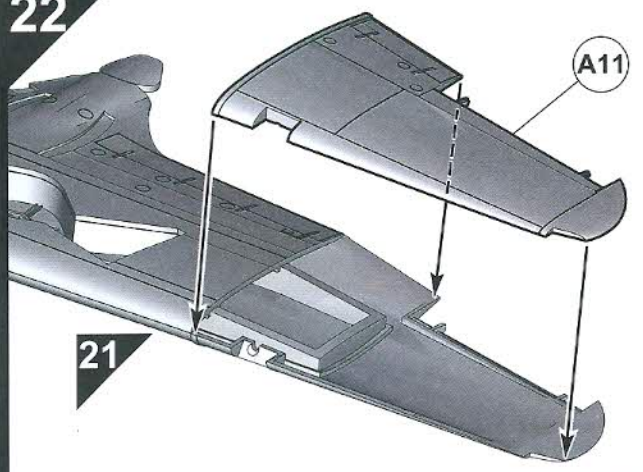

23

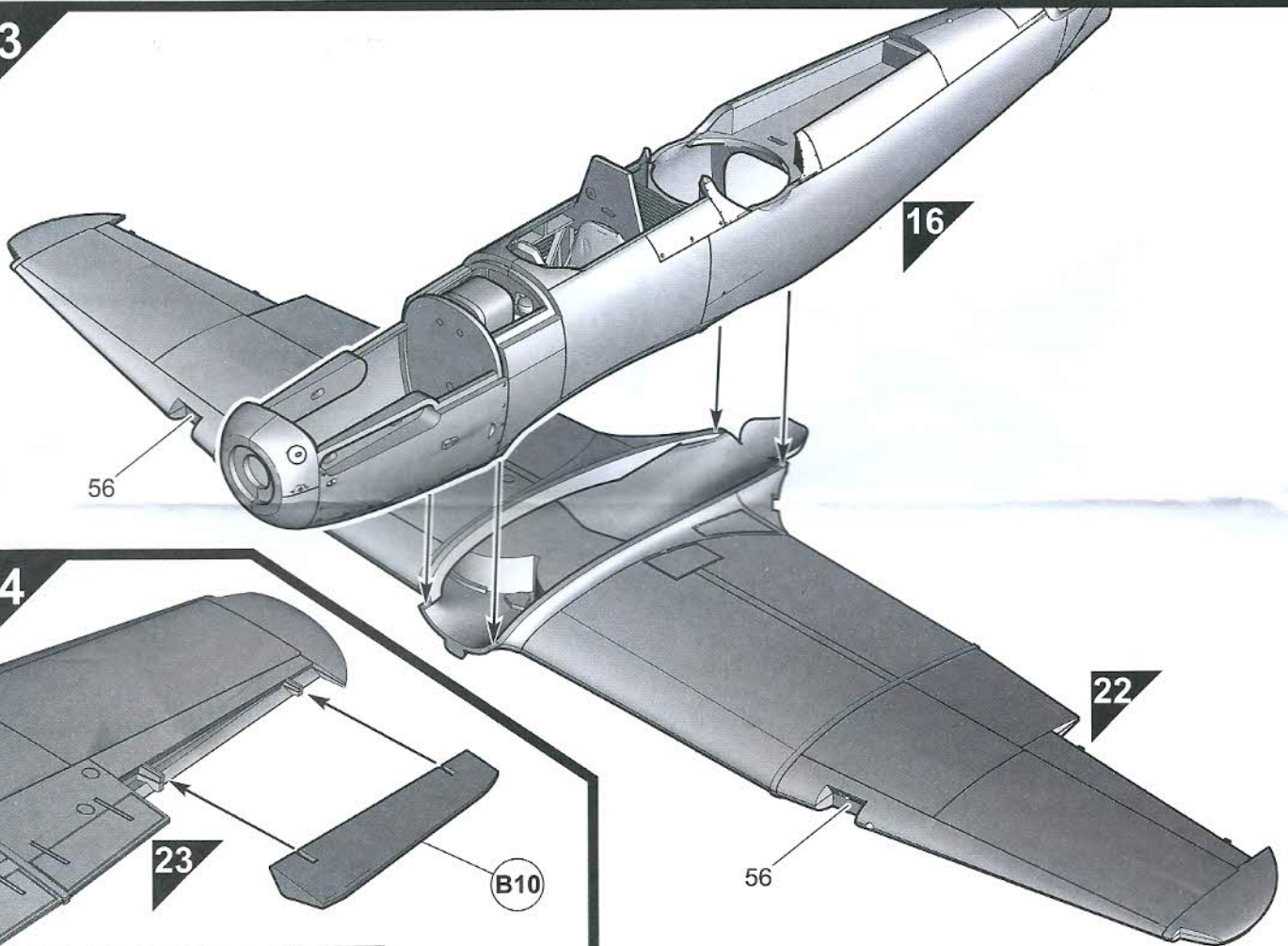

24

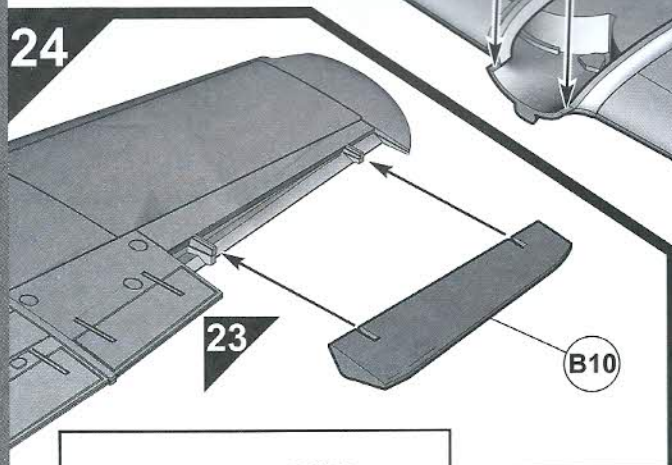

25

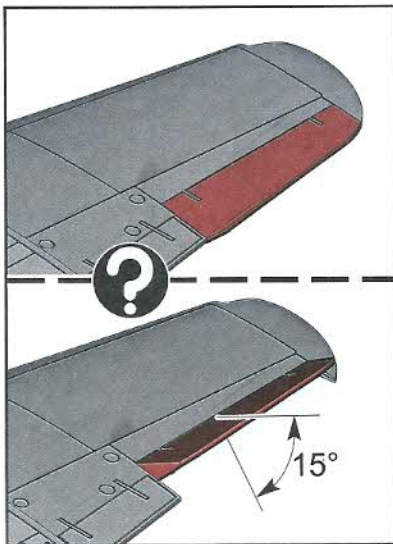
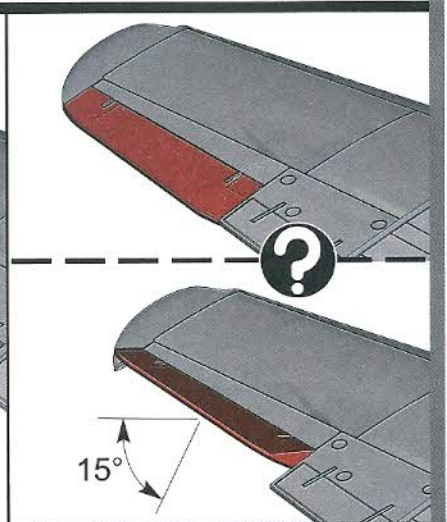
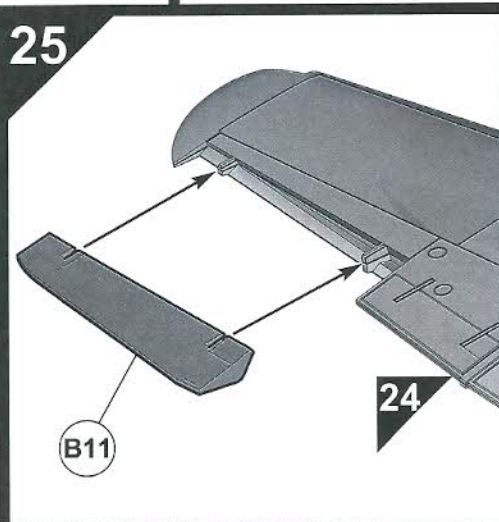

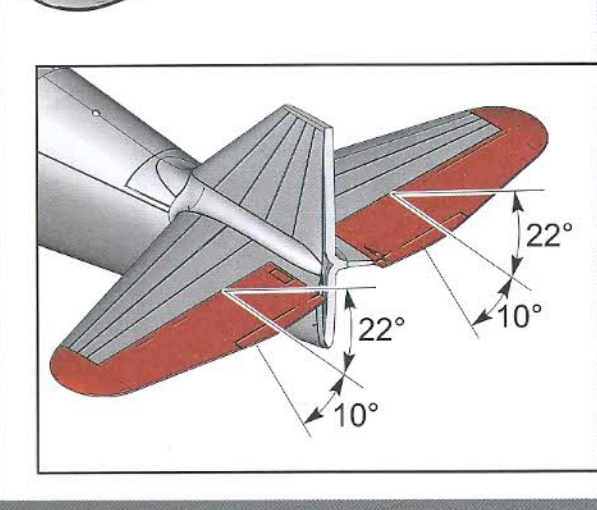
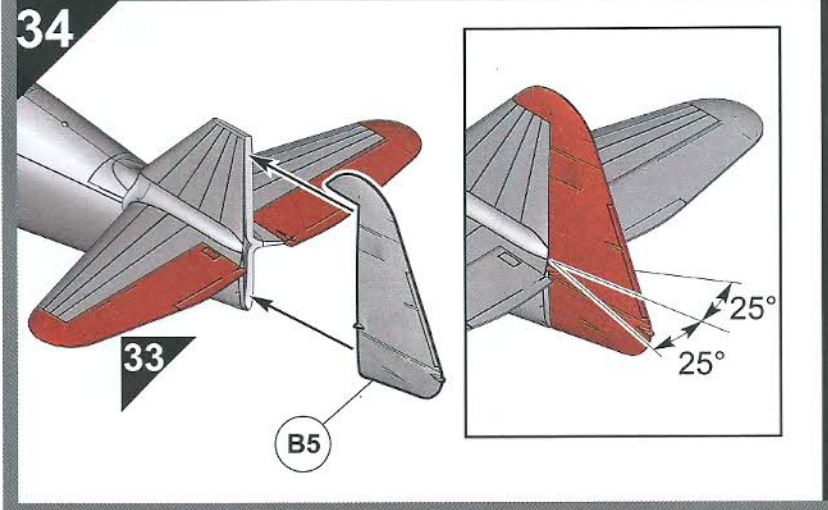
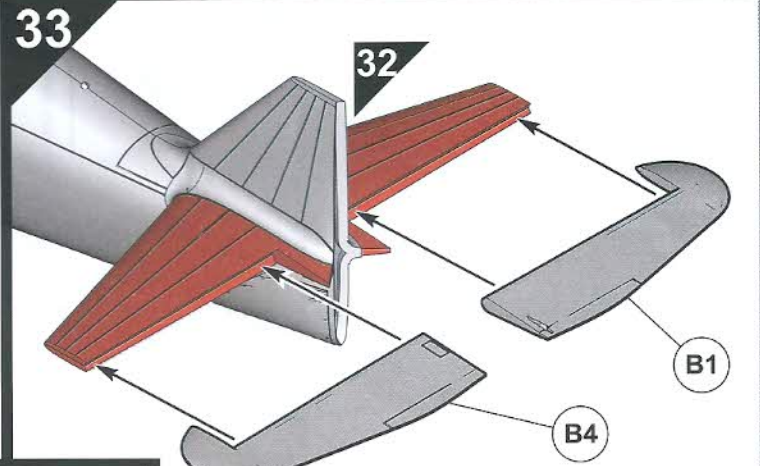
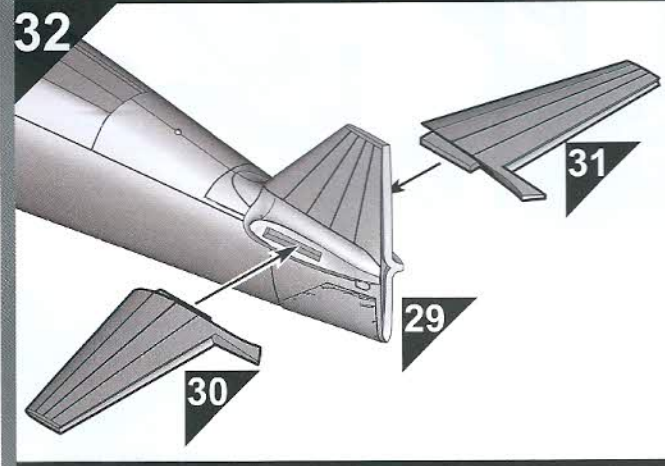
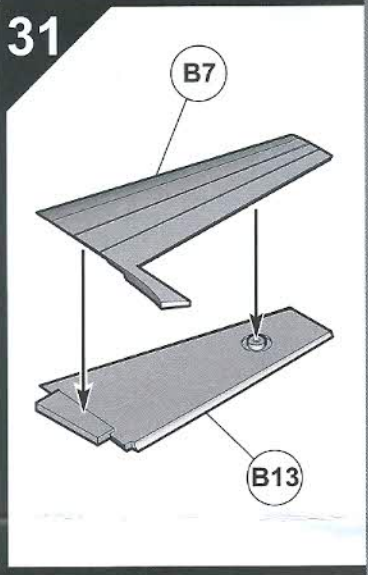
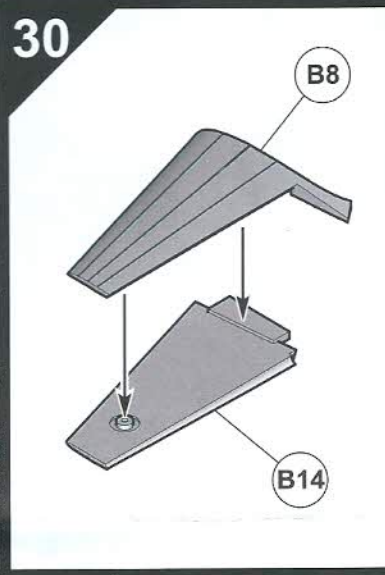
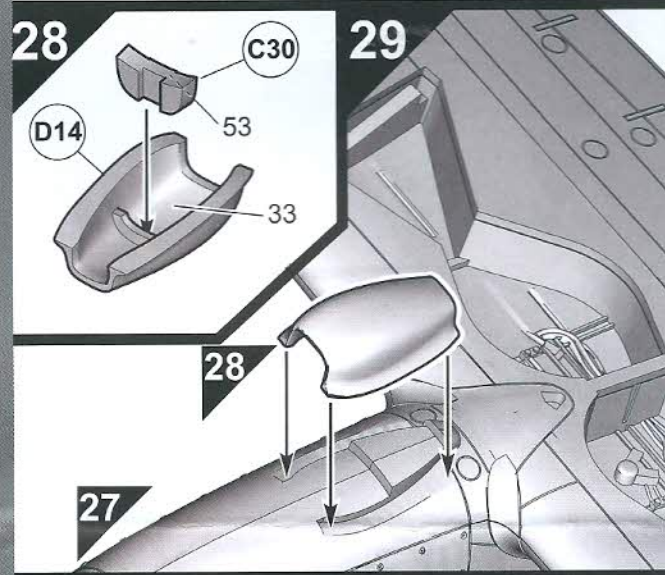
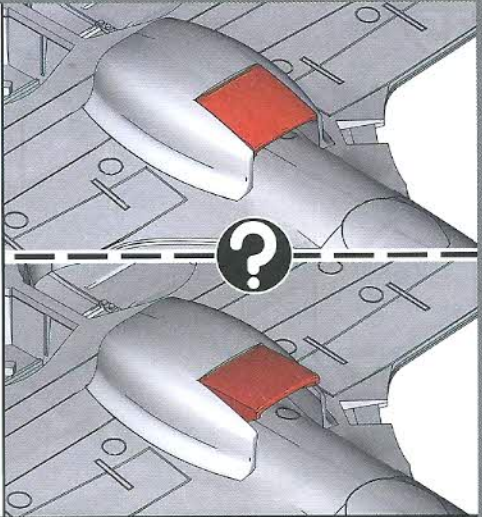
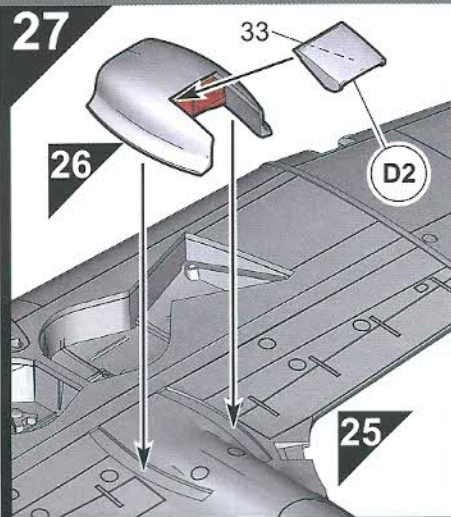
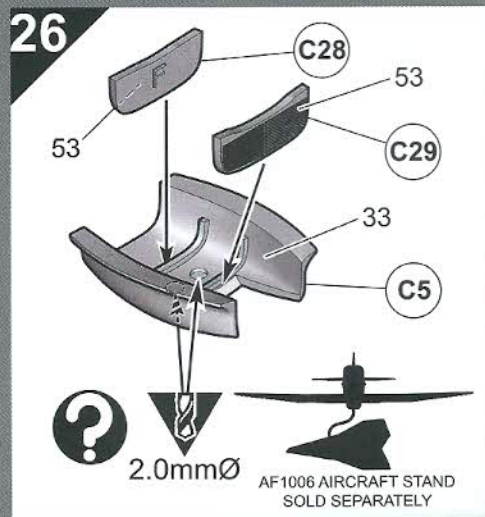

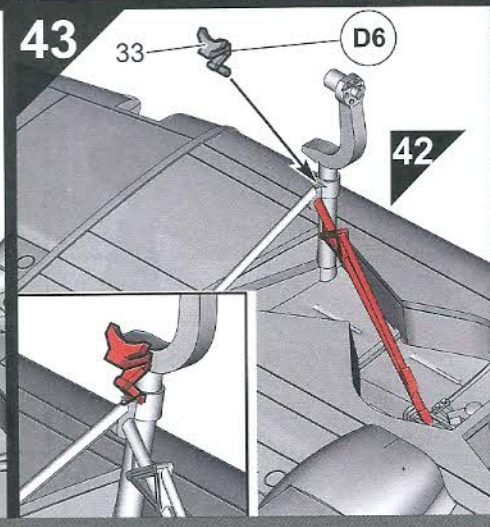
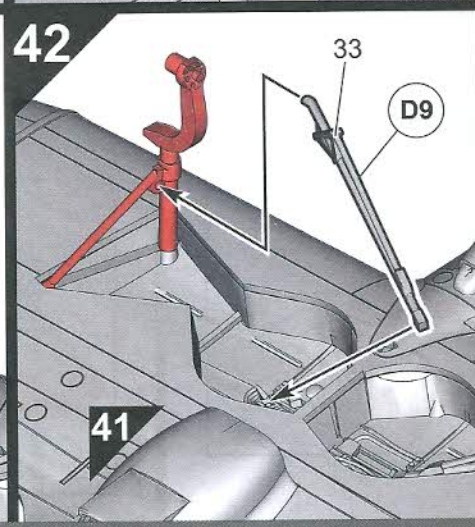
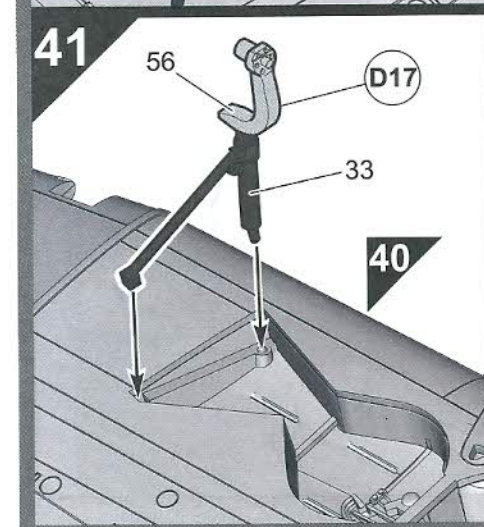
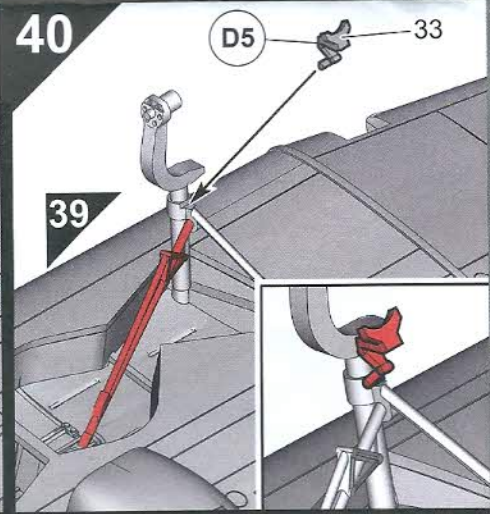
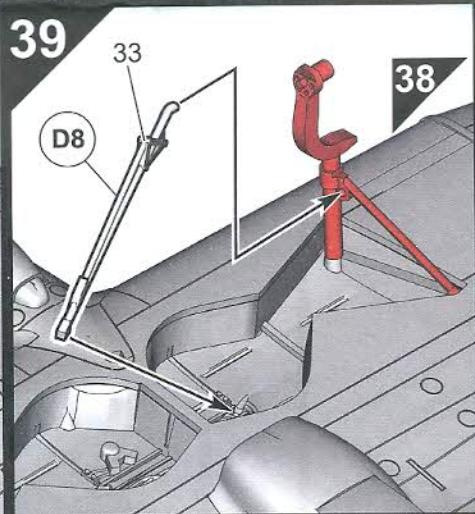
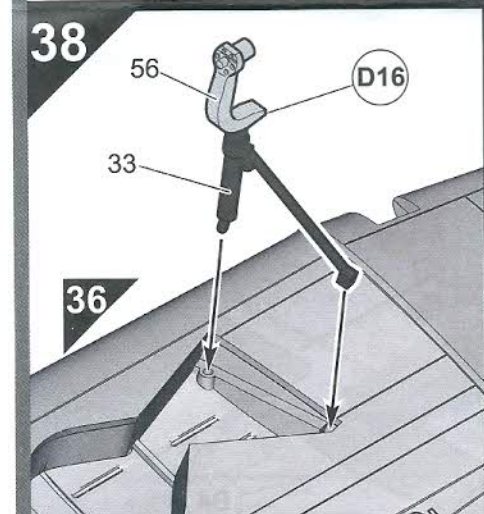
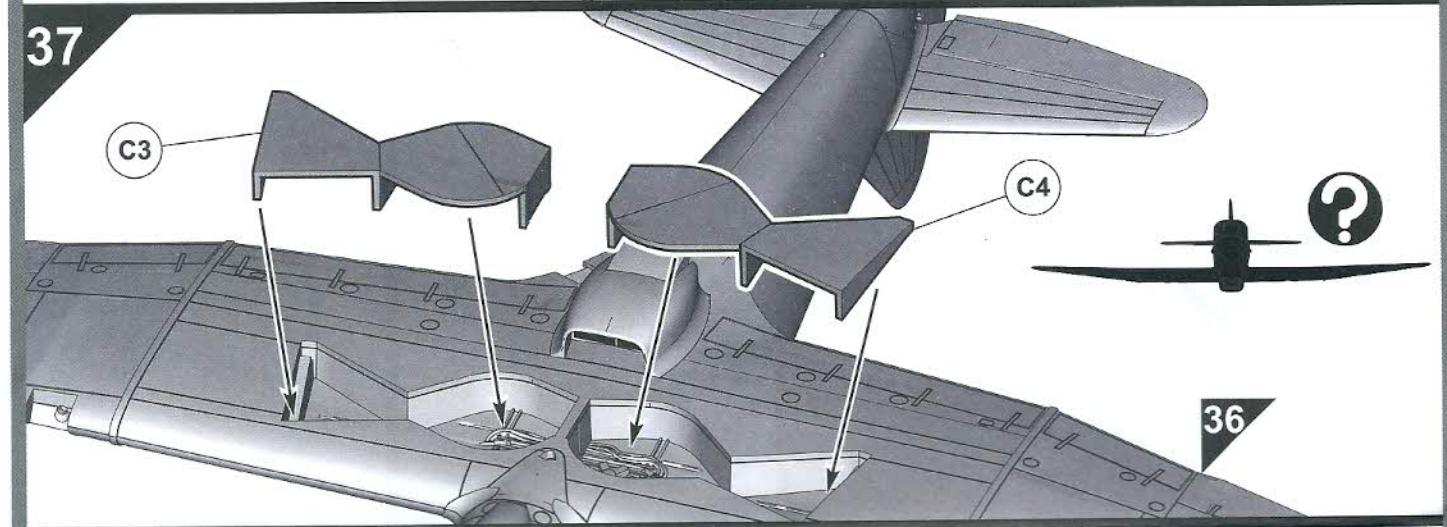
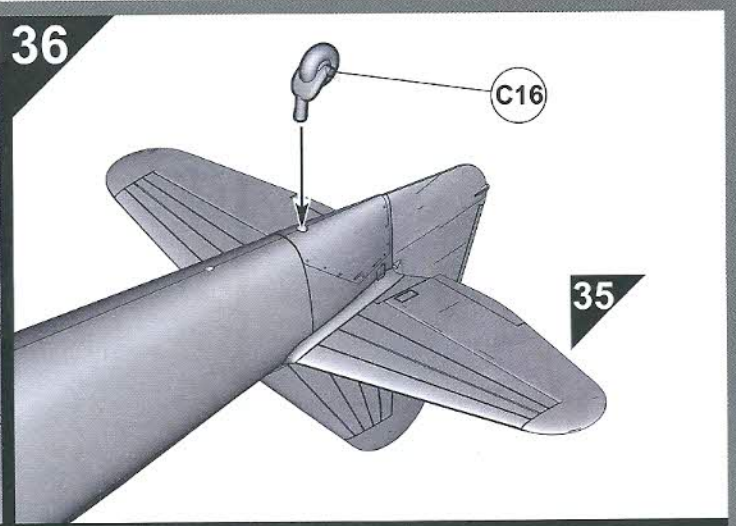
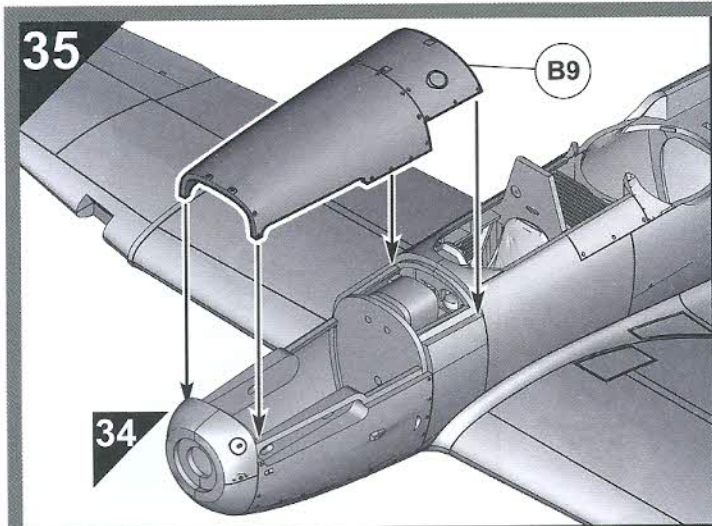

44

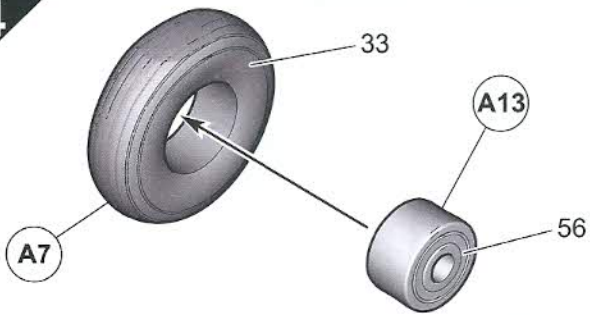

45

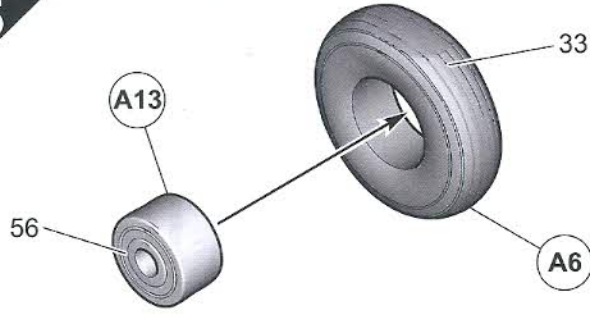

46

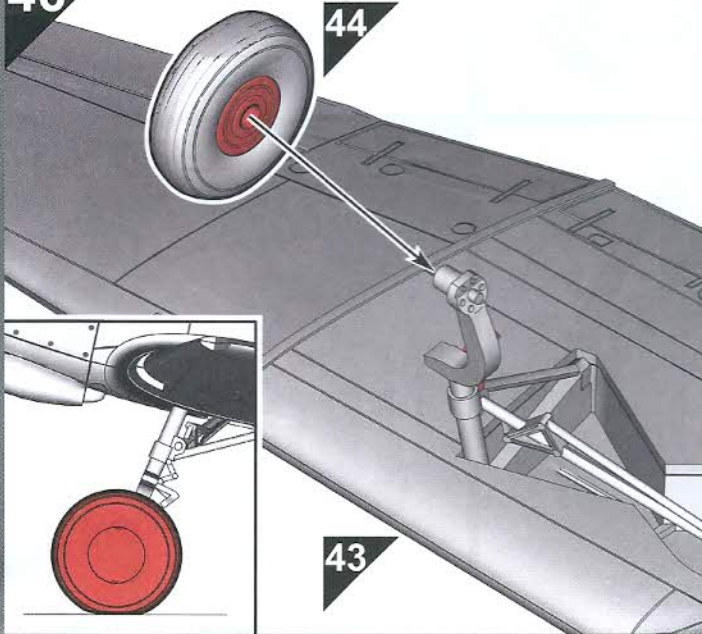

47

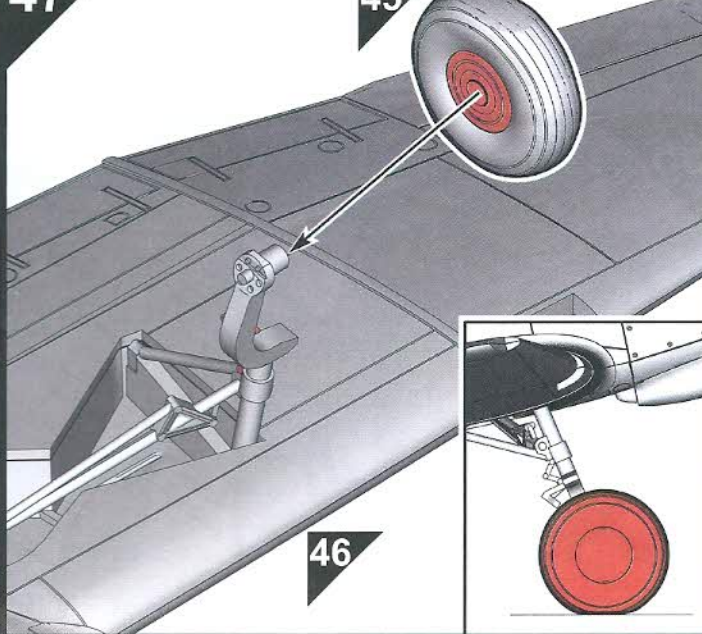

48

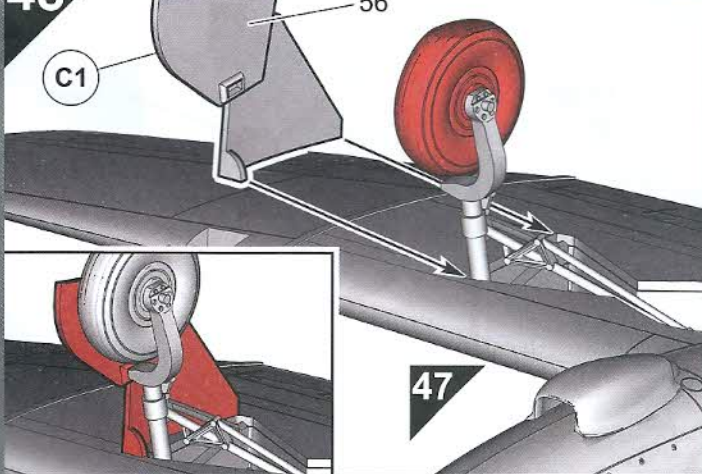

49

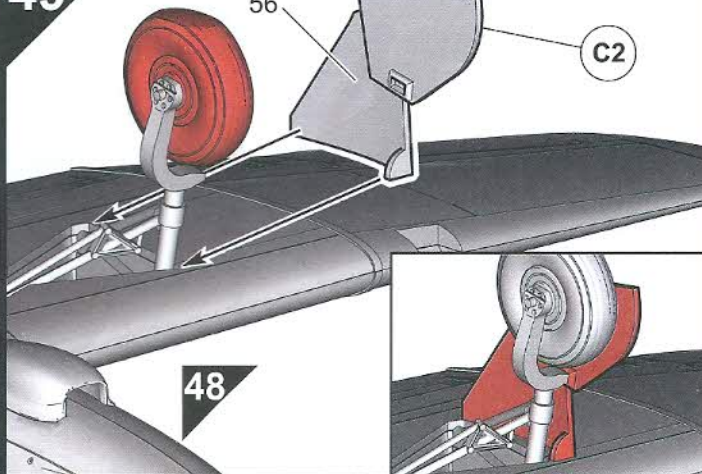

50

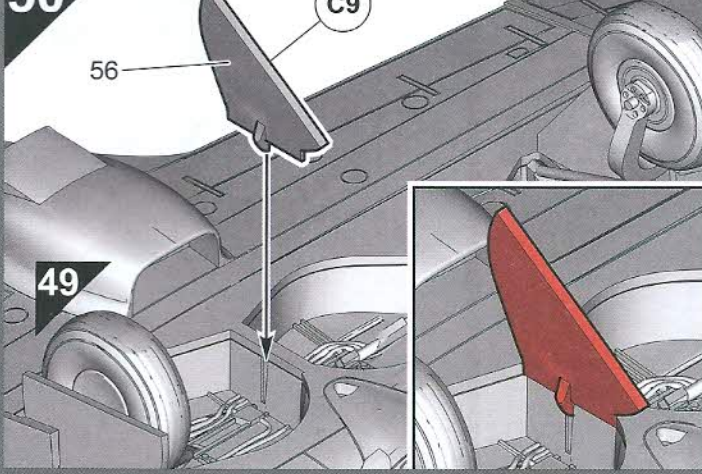

51

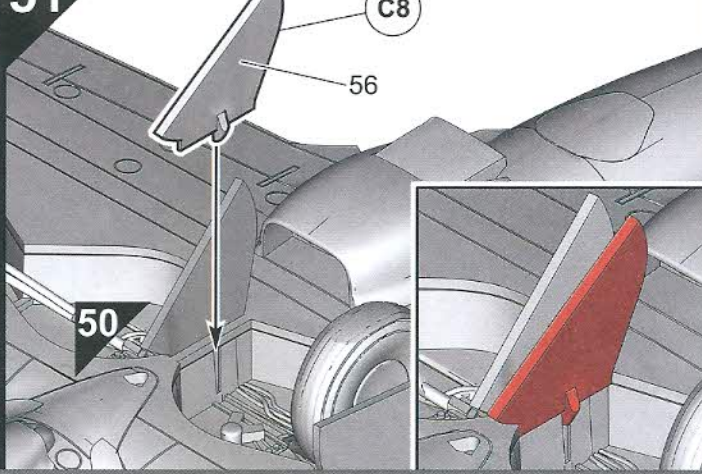

52

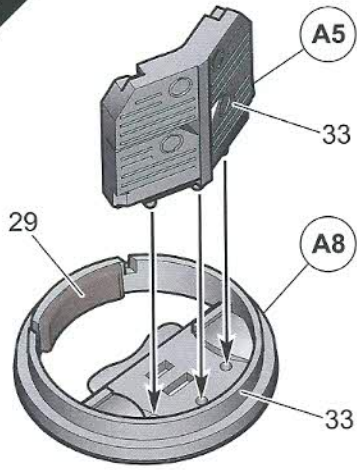

53

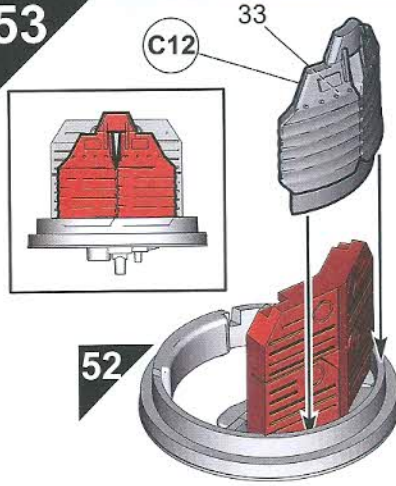

54

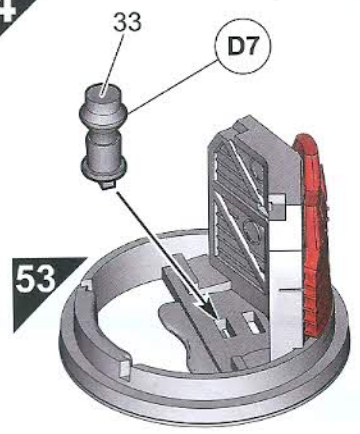

55

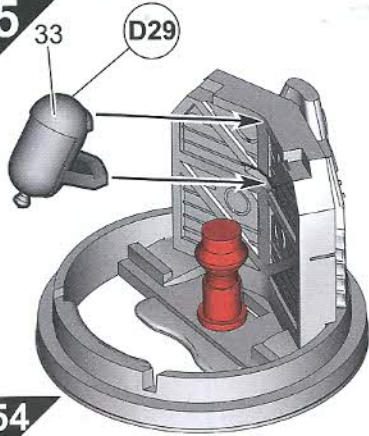

56

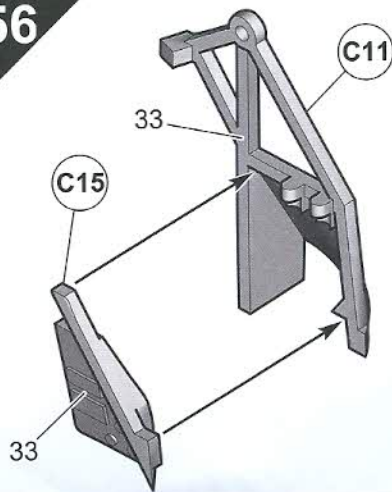

57

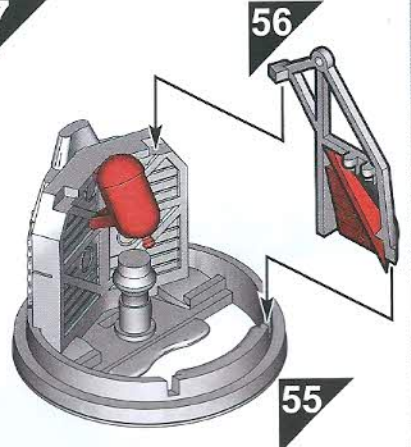

58

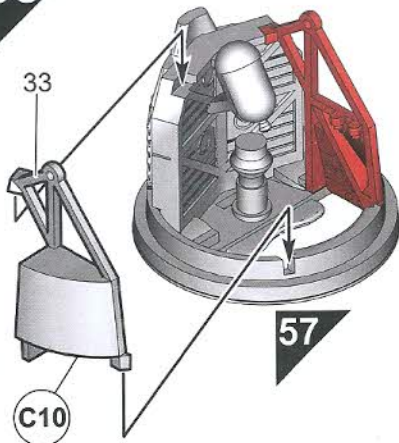

59

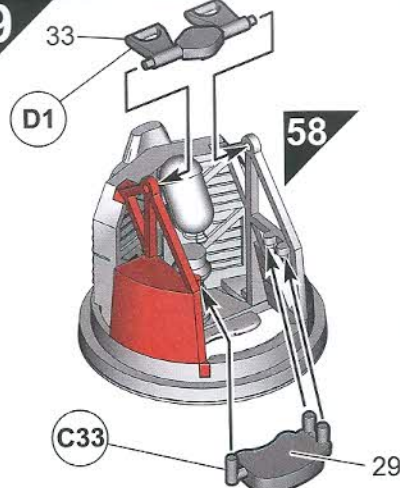

60

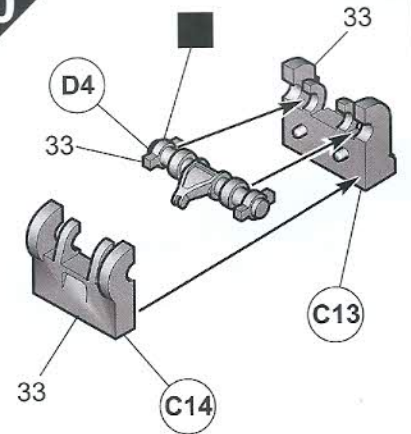

61

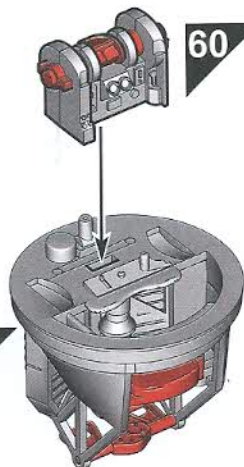

62

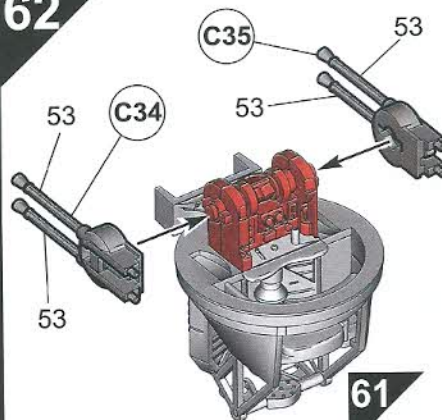

63

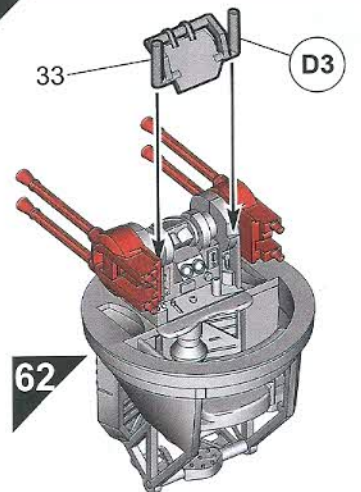

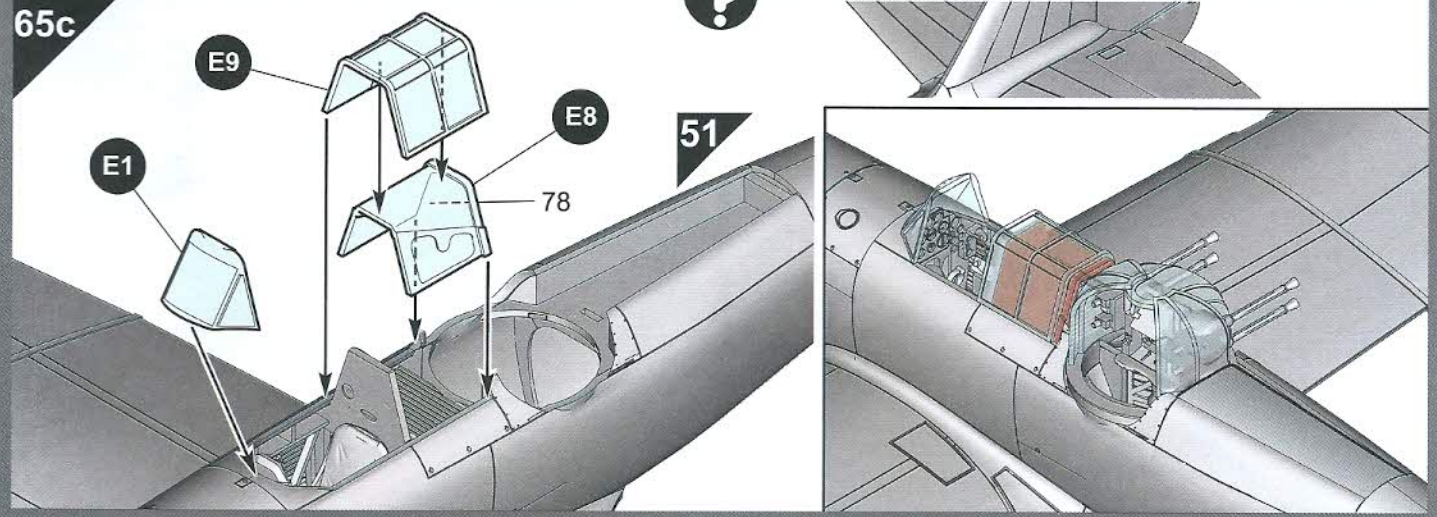
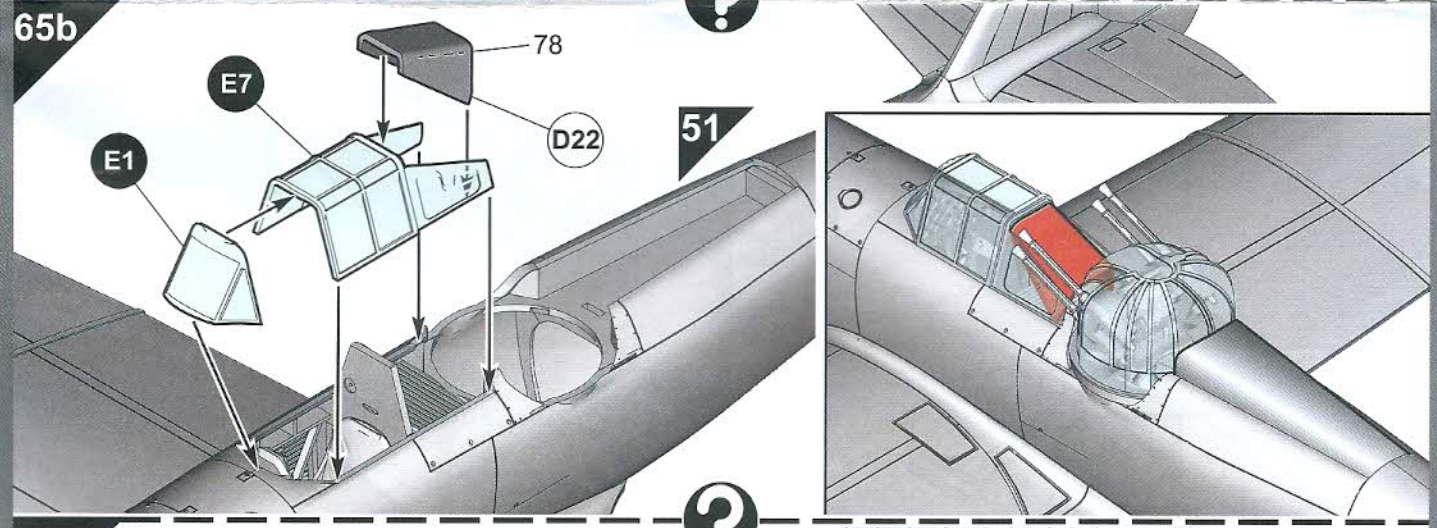
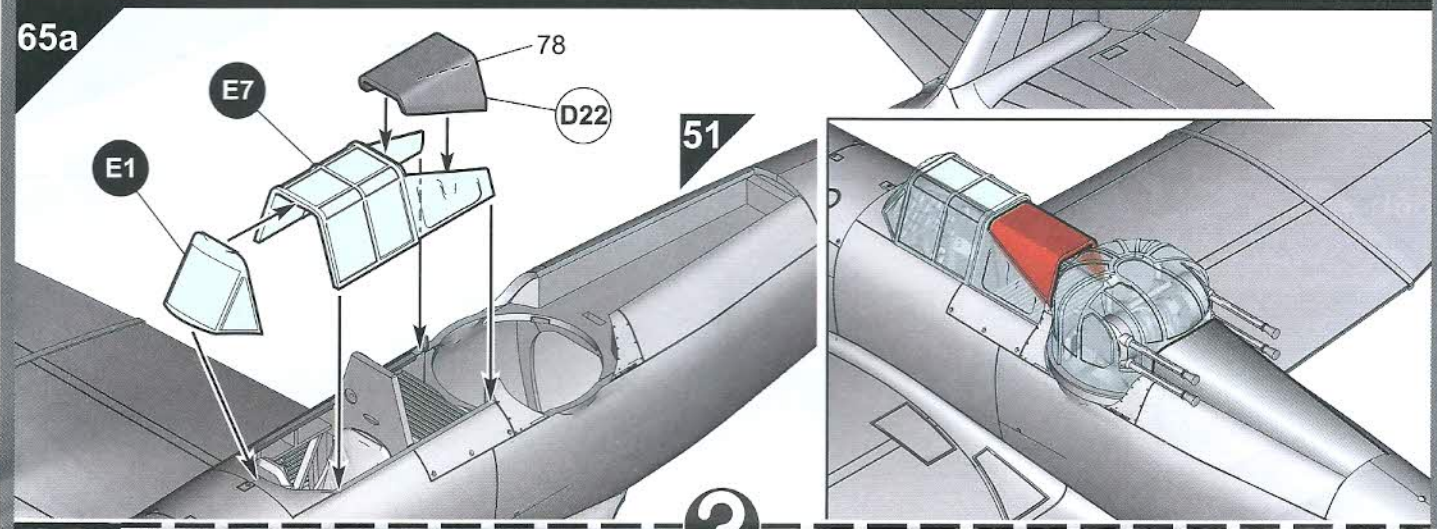
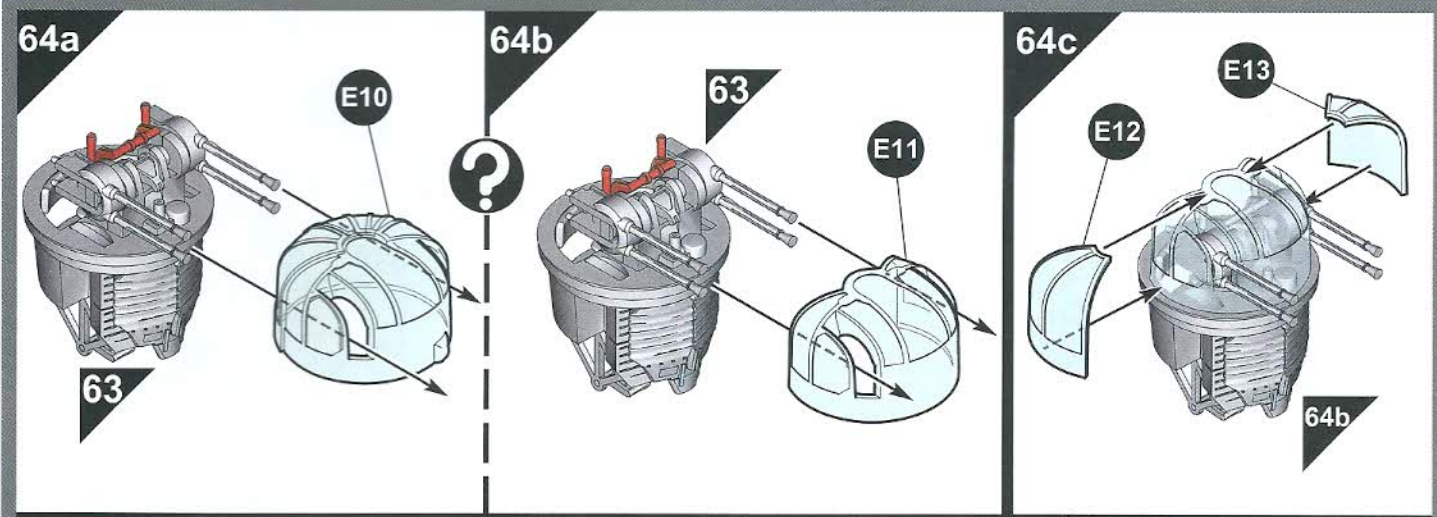

66a

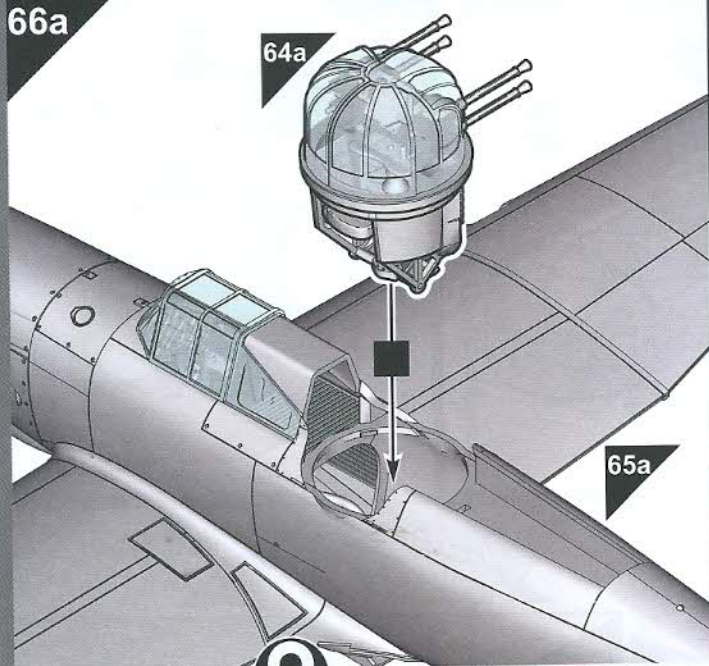

67a

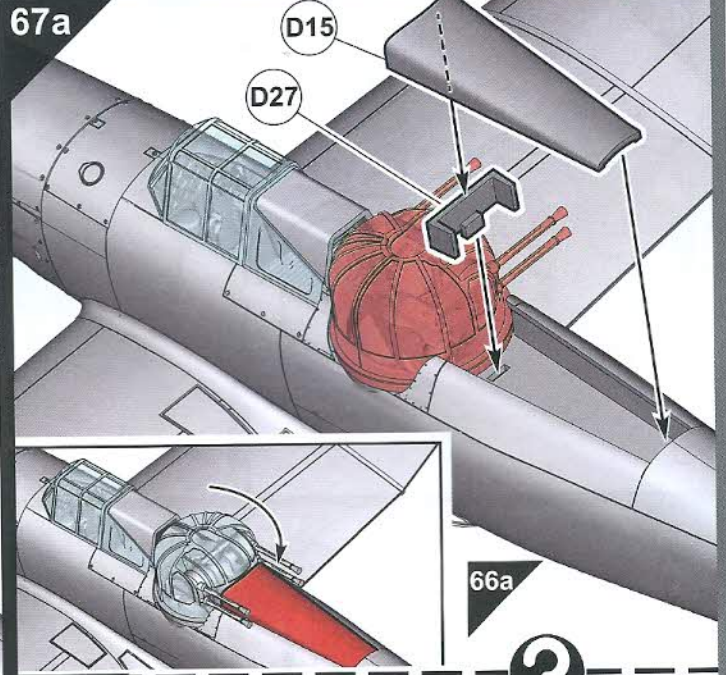

66b

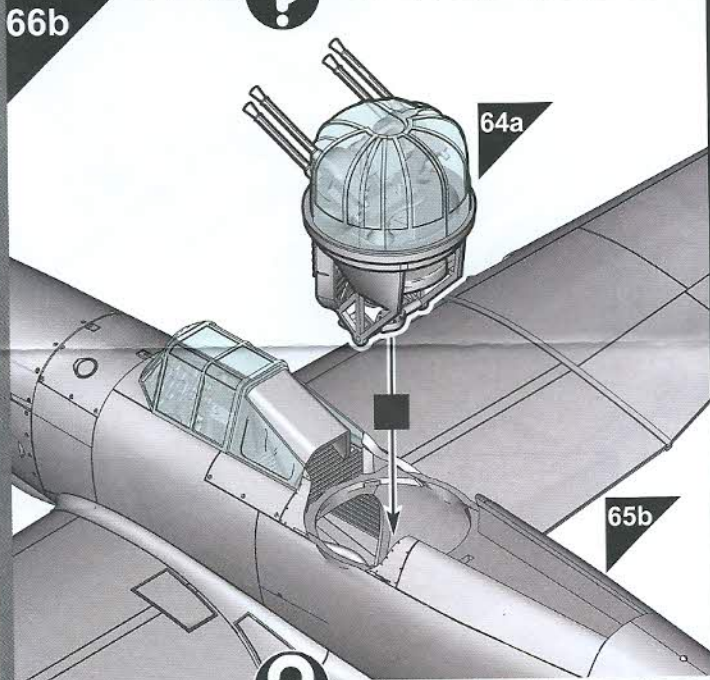

67b

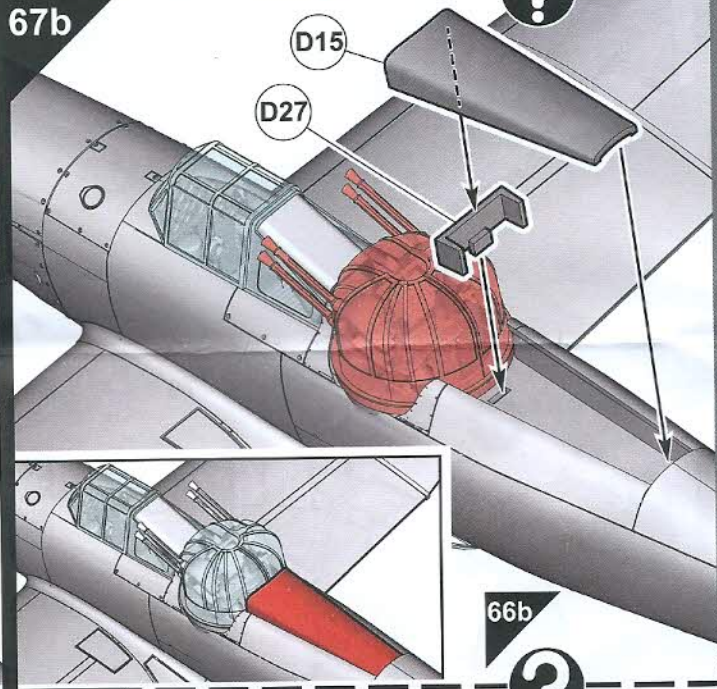

66c

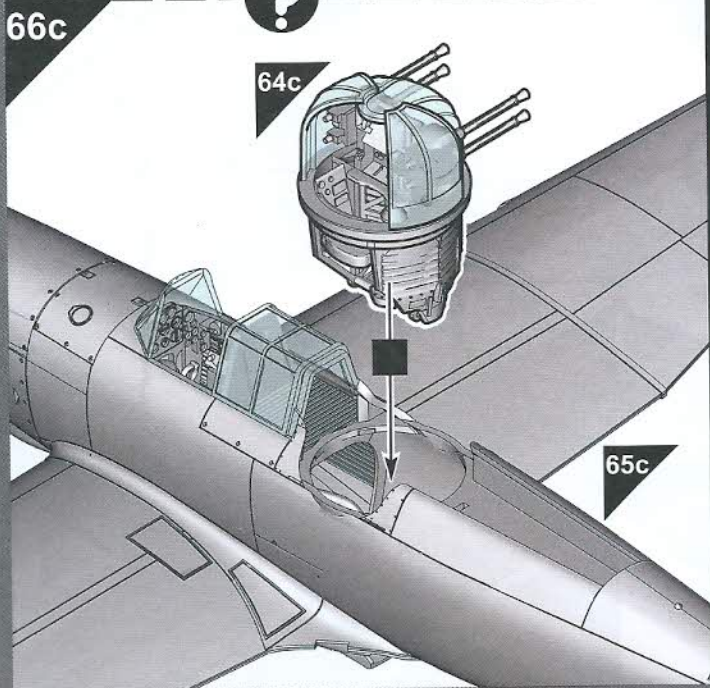

67c

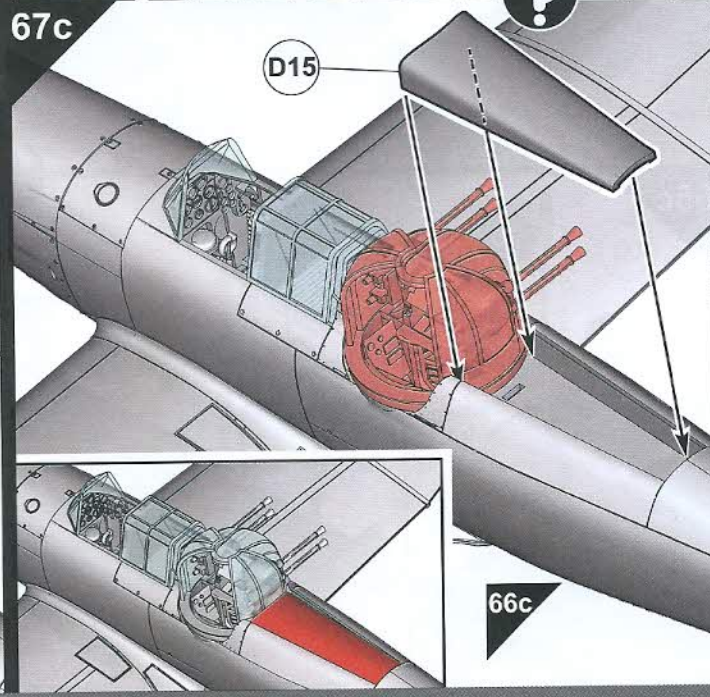

68

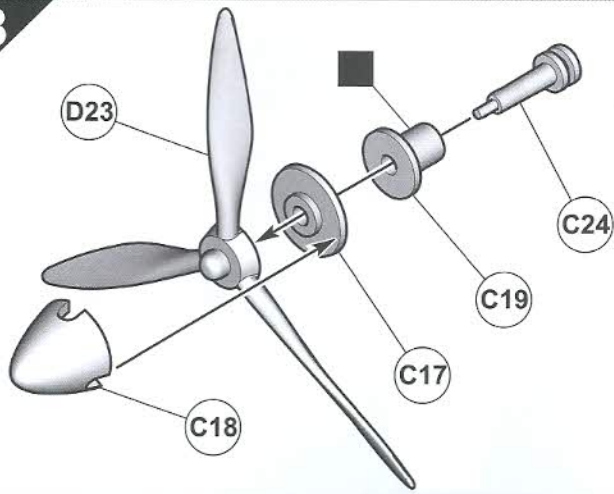

69

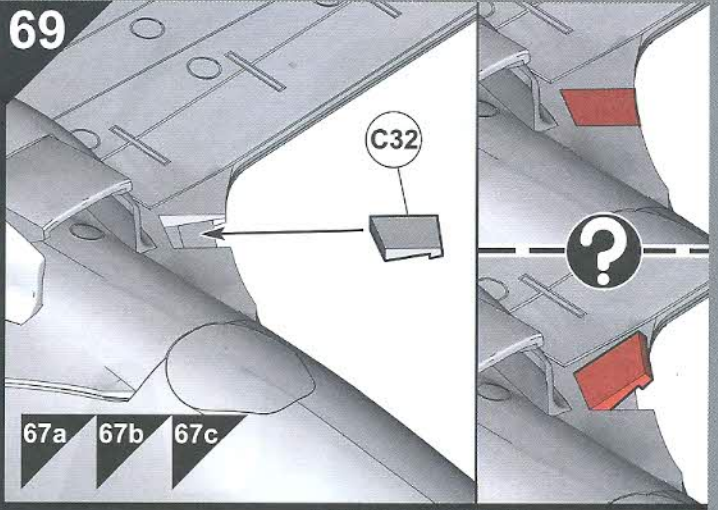

70

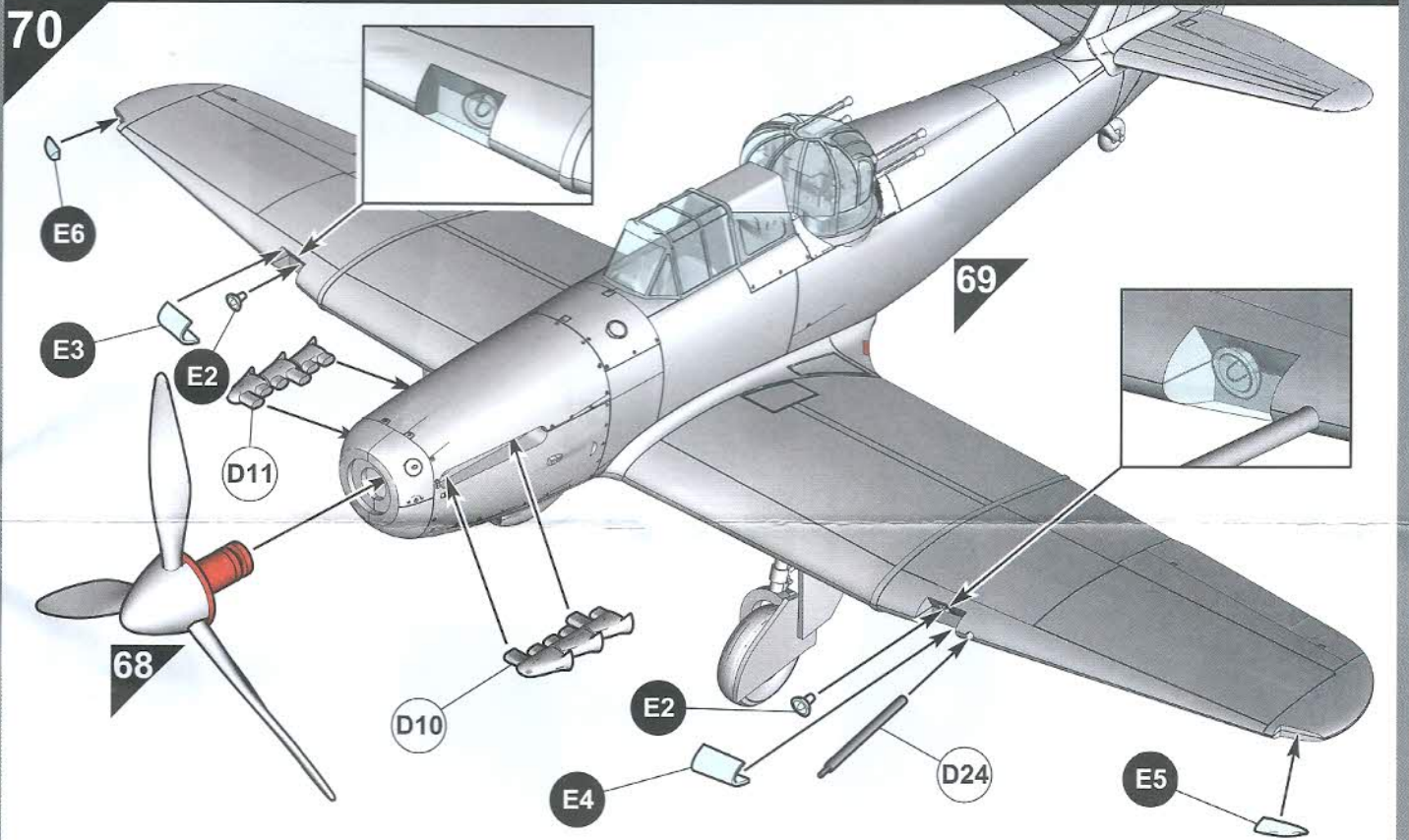

71

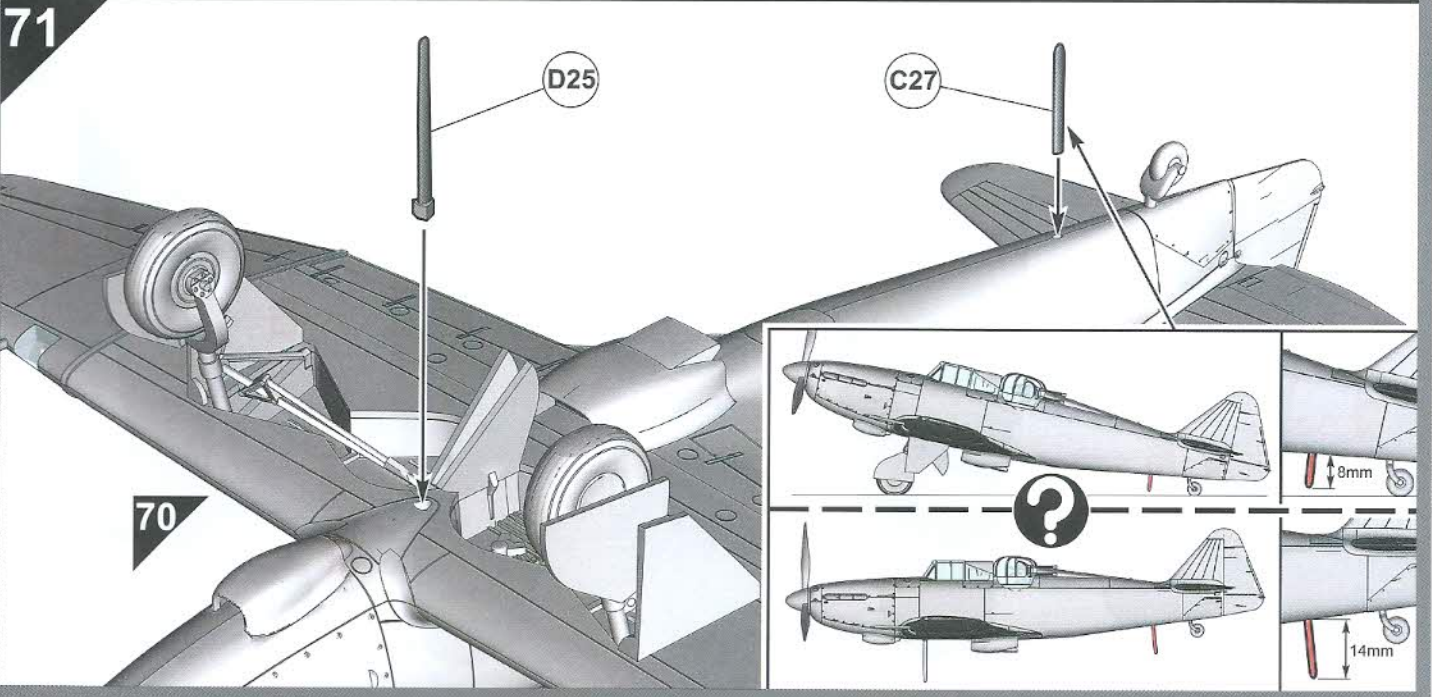

A Boulton Paul Defiant NF.1
 No.151 Squadron, Royal Air Force Wittering, Cambridgeshire, England, February 1941.

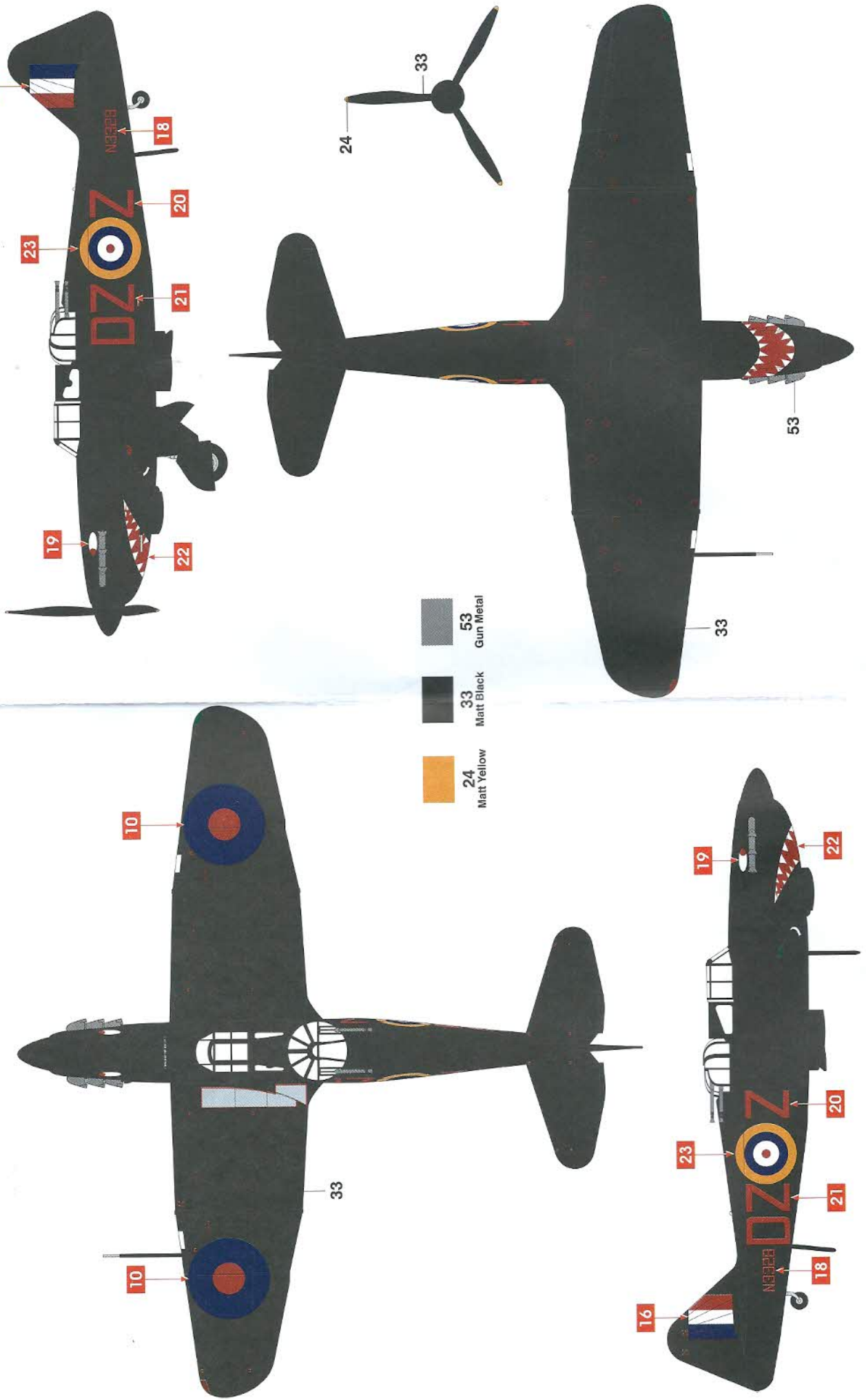

B Boulton Paul Defiant NF.I

Aircraft flown by Squadron Leader Philip James Saunders, No.264 Squadron, Royal Air Force Debden and Biggin Hill, England, December 1940/February 1941.

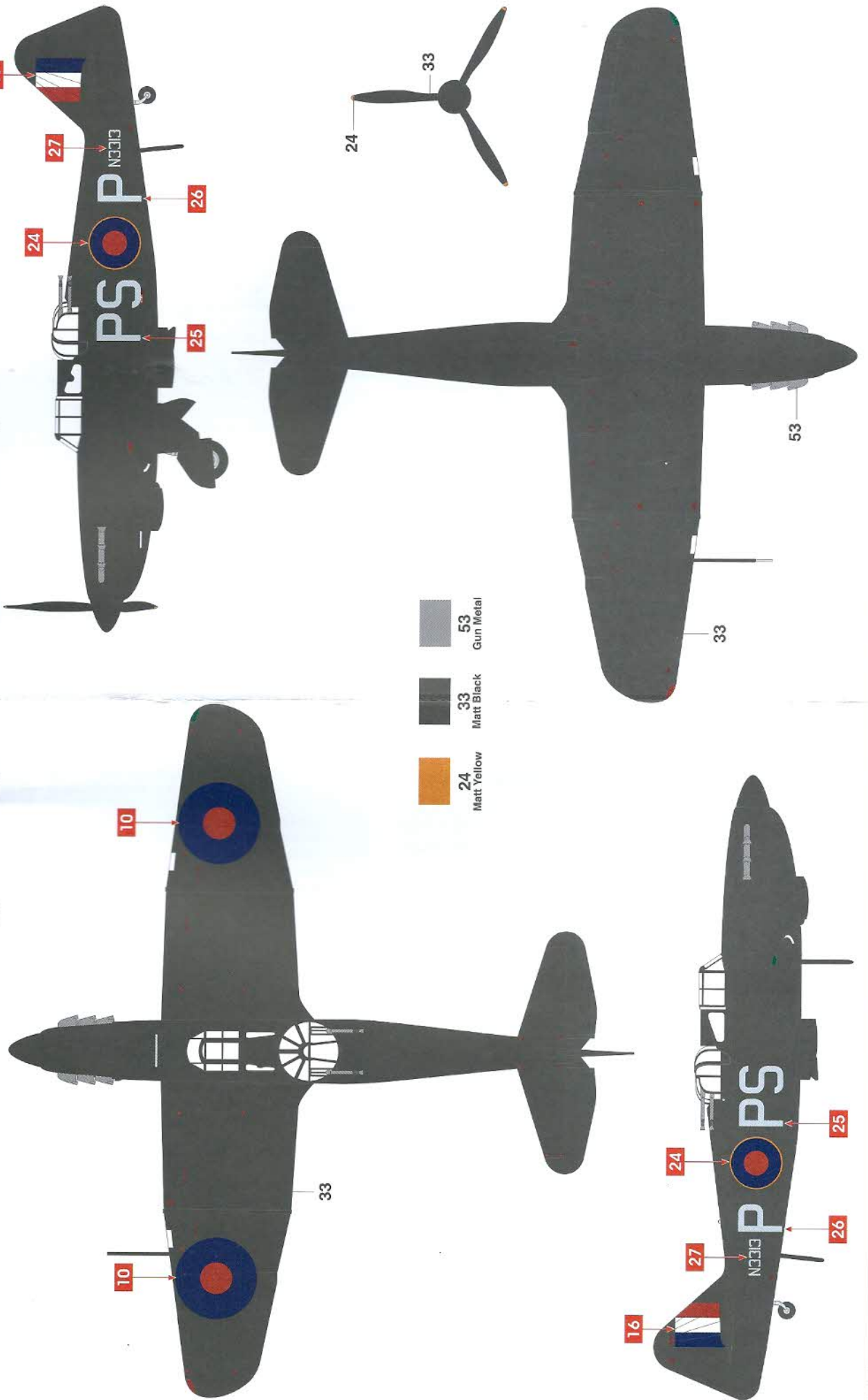

Boulton Paul Defiant NF.1

Position of common stencil data

