

P-47D THUNDERBOLT Razorback

1:32 SCALE

P-47D雷电"剃刀背"战斗机

READ BEFORE ASSEMBLY:

- This kit is not recommended for inexperienced modelers or for children under 14 years of age
- Study and understand these instructions thoroughly before beginning assembly
- When needed, remove photo-etch parts carefully using a modeling knife or photo etch sprue cutter, being careful not to damage or lose small parts.
- Take extra care in handling photo etch parts in order to avoid injury
- Apply instant cement sparingly to photo etch parts where instructed

- Tools recommended(not included in kit):Plastic and instant cements,sprue cutters,long nose pliers,modeling knife, small files, tweezers, pin vise & scissors. Soft cloth and sandpaper will also assist in construction
- Glue and paint are not included in the kit. Use plastic cement and hobby paints only. Color guide for purchasing paint is included in the kit.
- Keep out of reach of children. They must not be allowed to ingest small parts or handle plastic bags in any way.

装配之前仔细阅读

- 小心用模型锉刀锉平所有零件表面的注射浇口。
- 小心用刀片切下蚀刻片零件，不要遗失小零件。
- 用强力快干胶水粘合蚀刻片零件和金属轴。过量的快干胶水使用可能导致可动零件会粘住，小心涂胶。
- 取蚀刻片时应特别注意安全，防止利边划伤手指。
- 某些零件表面需贴水上贴纸，请选择在装配的同时进行。
- 推荐模型工具(自备)：胶水，水口剪刀，长咀钳，刀片，锉刀，镊子钳，钻，剪刀，瞬间快干胶。
- 软布同砂纸同时也应该是必备工具。
- 请使用塑料胶水和油漆，模型内不含。
- 谨防小孩吸吮塑料零件，或者将塑料袋套在头上，制作时应将套材远离小孩接触。
- 本产品不适合14岁以下没有经验的模型爱好者。

水贴纸的使用:

1. 从水贴上剪下印花;
2. 将印花放入温水中浸10秒, 然后放在干净布上.
3. 拿着印花纸板将印花移到模型上;
4. 手指蘸水将印花移到适当的位置;
5. 用软布轻压印花直至水干, 气泡消失.

DECAL APPLICATION:

1. Cut decals from sheet as needed
2. Dip the decal in warm water for about 10 seconds and then place on soft clean cloth.
3. Hold the decal backing sheet edge and gently slide the decal onto the model in its proper position.

4. While still wet, decal can be adjusted for better fit on model by dampening it gently with your finger.
5. When placed in the proper position, gently press decal down with a soft cloth until excess water and air bubbles are gone.
6. Allow decal to dry completely before handling model



cyanoacrylate glue
使用强力胶



weight
配重



make hole
钻孔



cut / remove
切除



option
选择



no cement
不涂胶水



decal
贴纸



bend
弯曲



file / sand
锉平

部品图

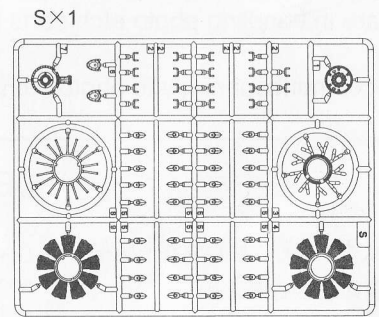
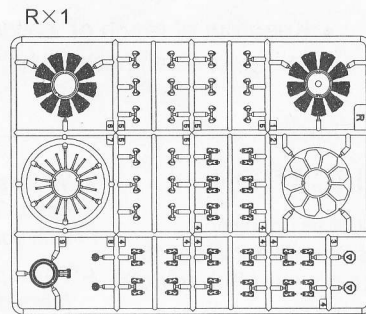
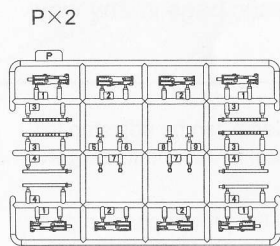
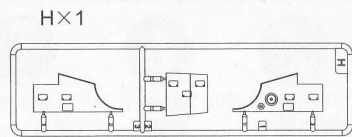
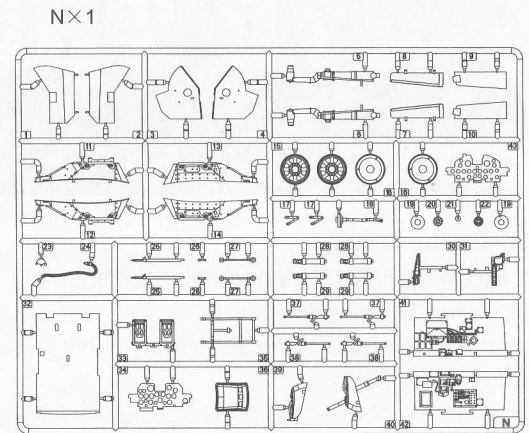
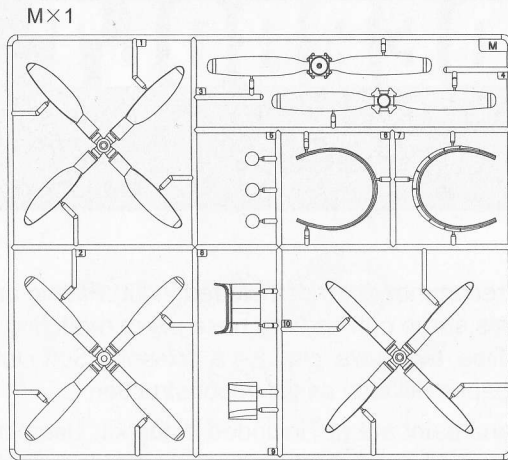
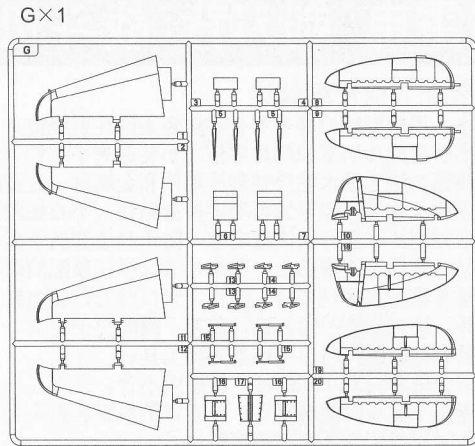
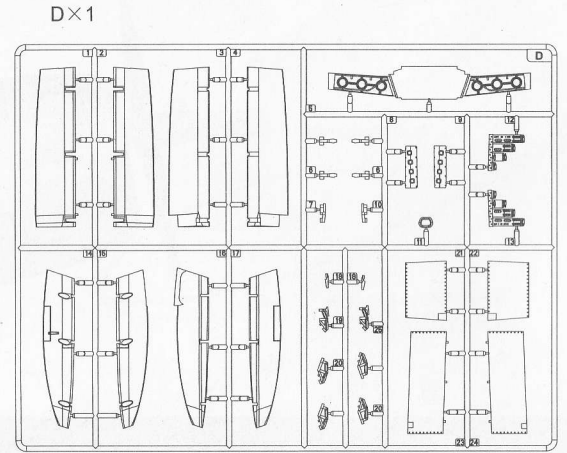
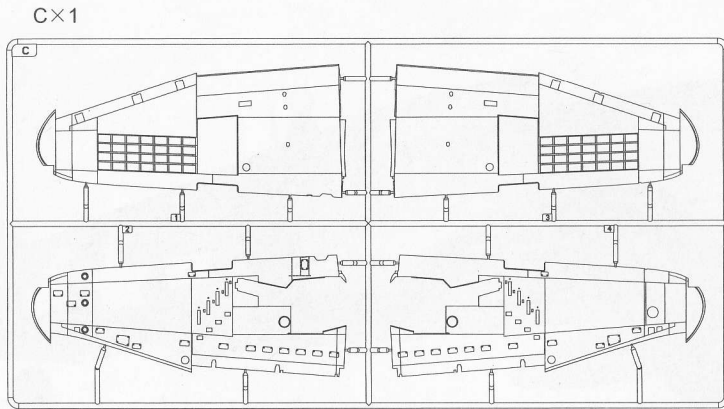
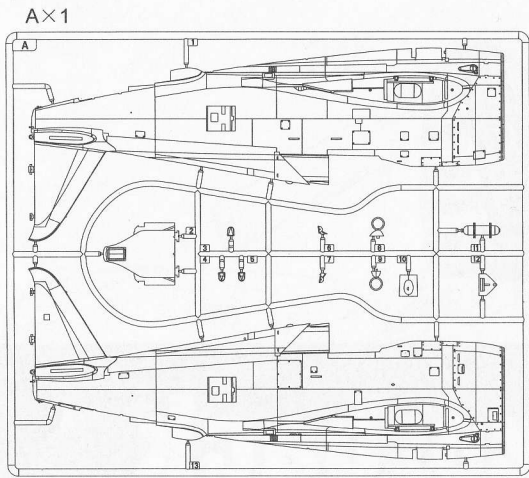

部品图

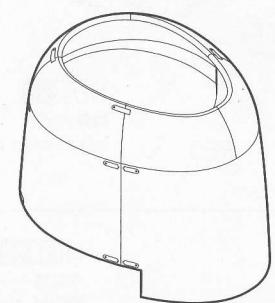
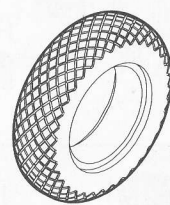
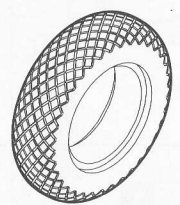
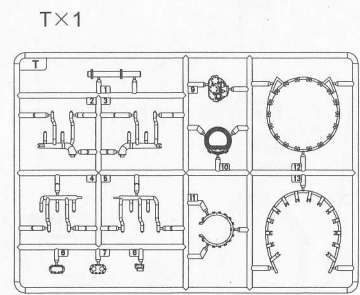
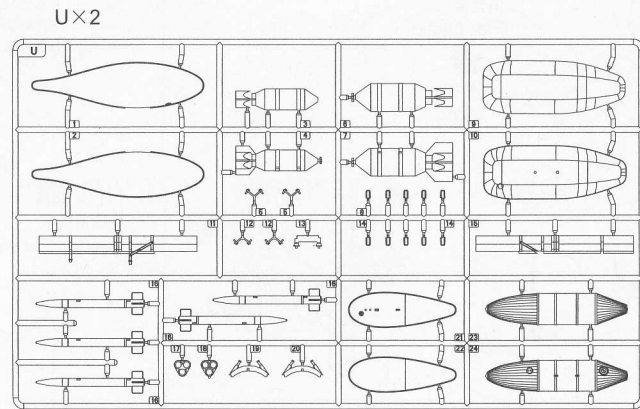
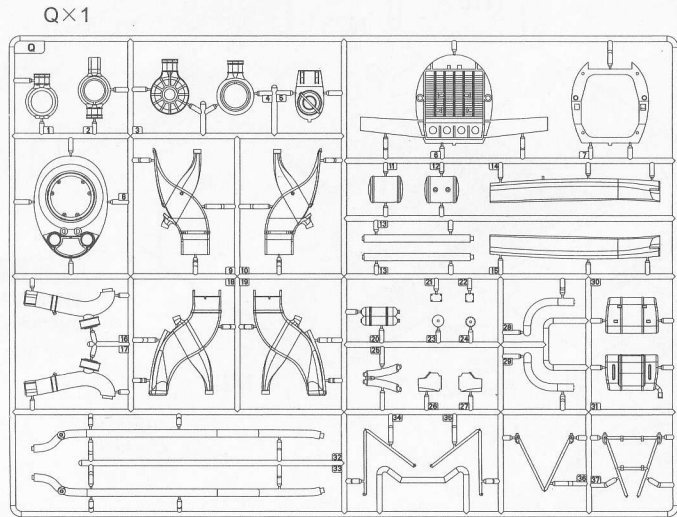

蚀刻片
Photo etched parts(PE)

主轮胎
Main Tyre

尾轮
Tail Tyre

引擎罩
Cowling

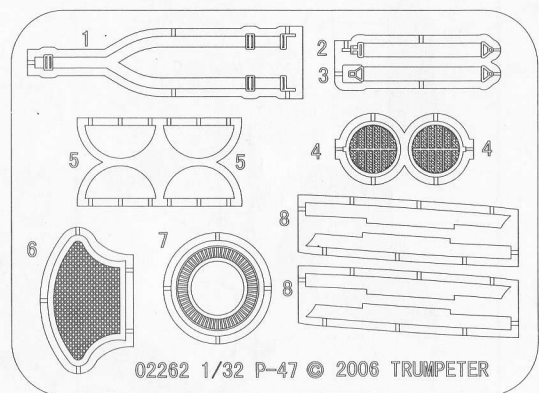
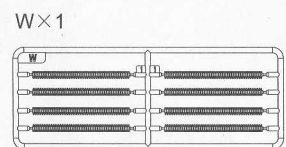
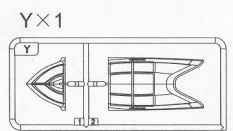
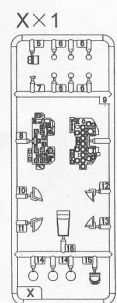

菲林片
Film Part:

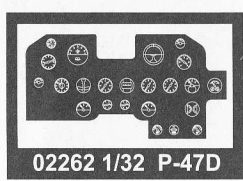

水贴
Decal

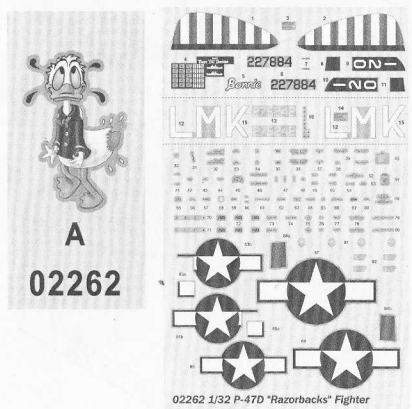

不用的部件:
unused parts N34 U8 U14 U16 X8 X10 X11

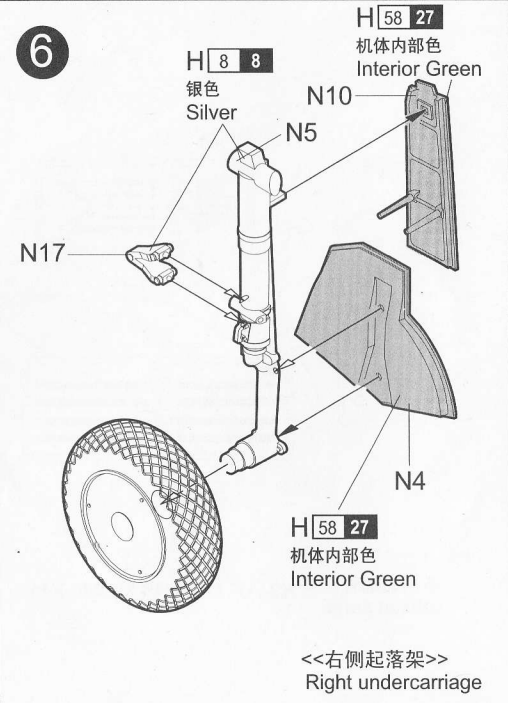
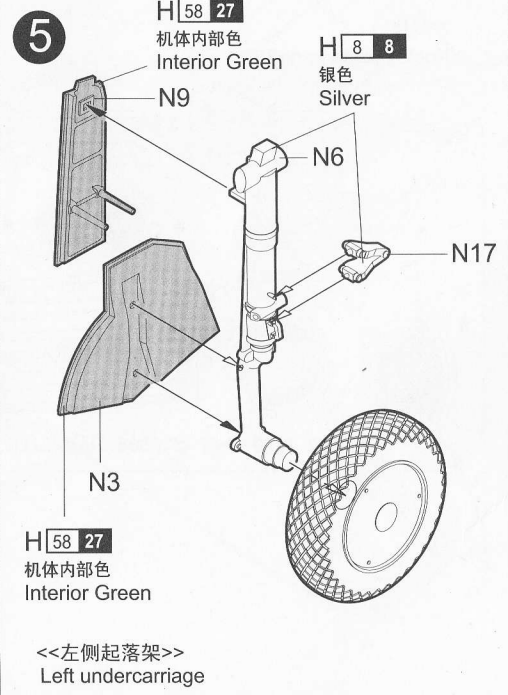
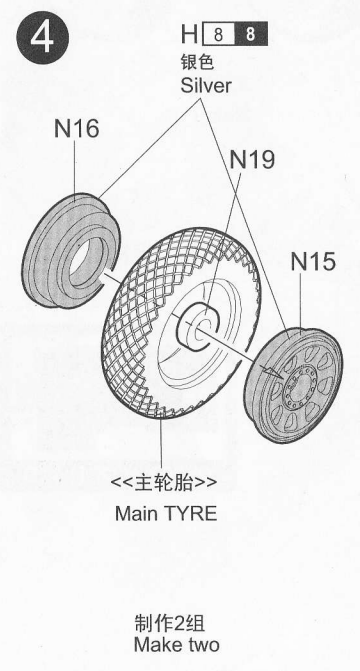
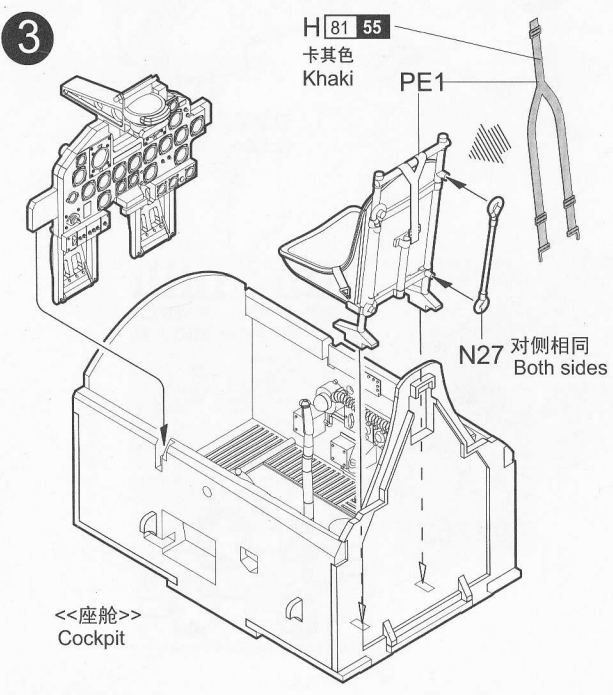
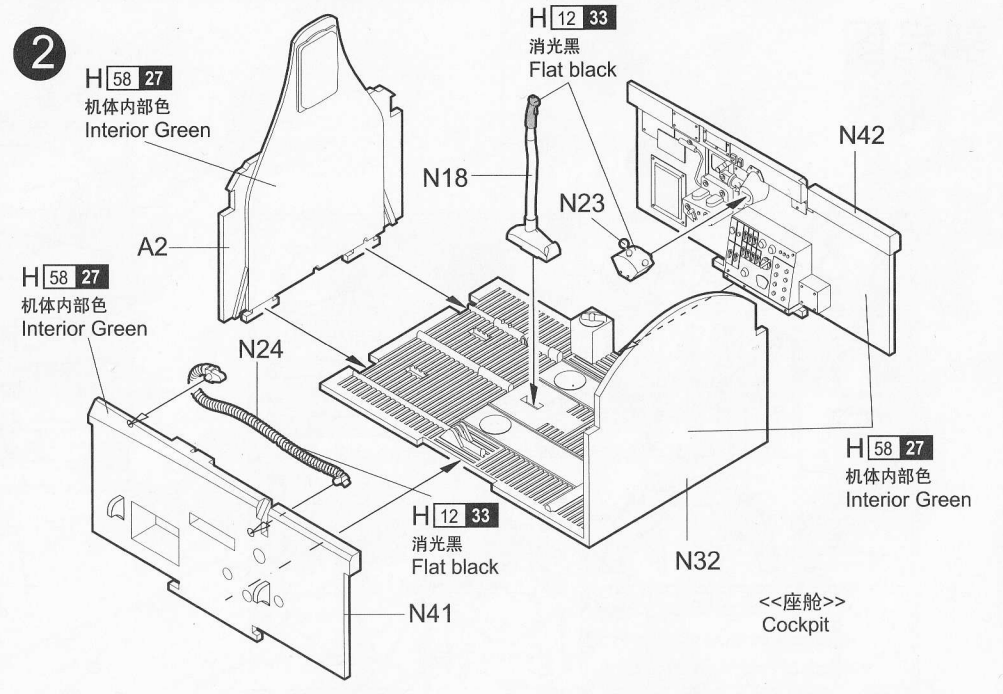
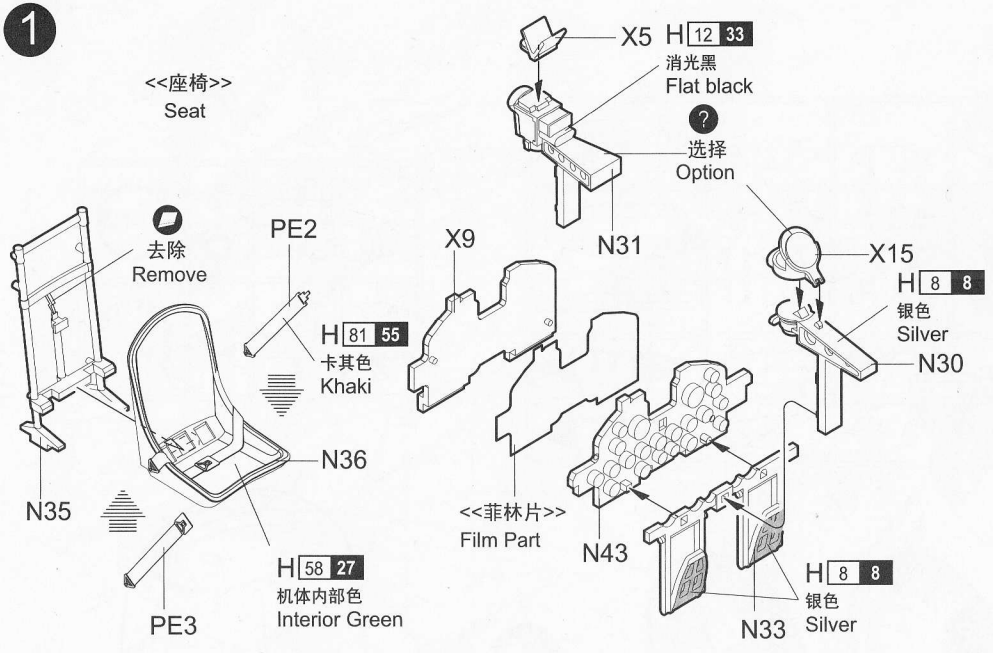

7

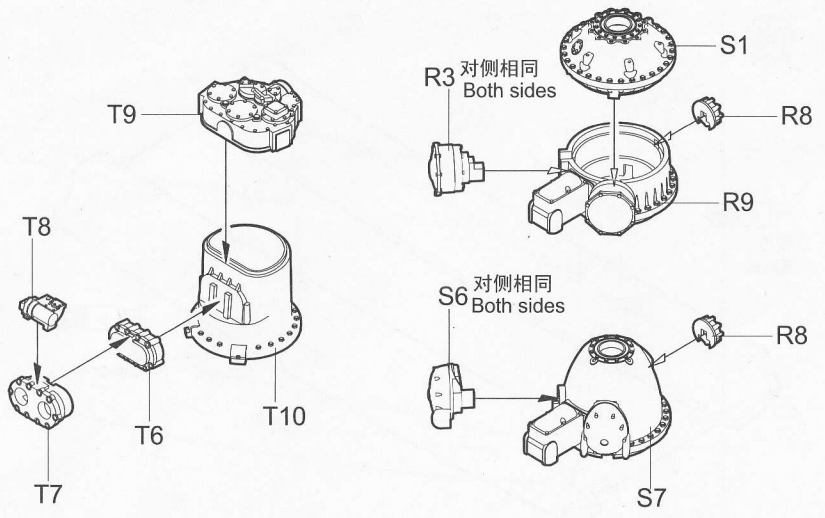

8

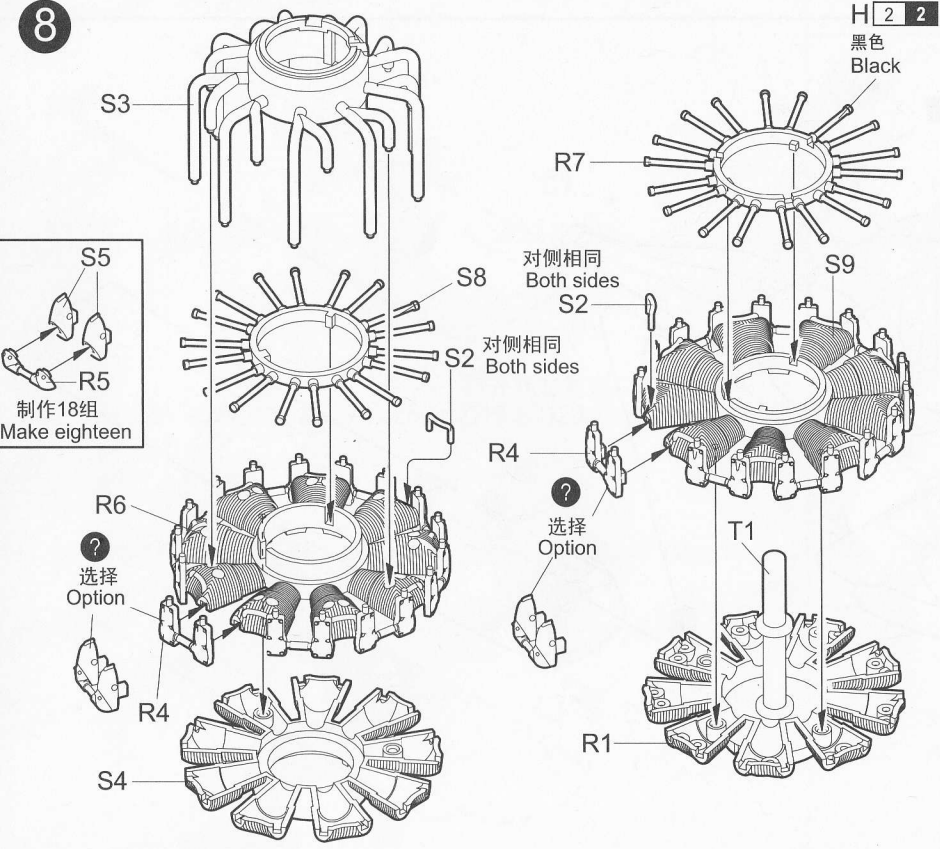

9

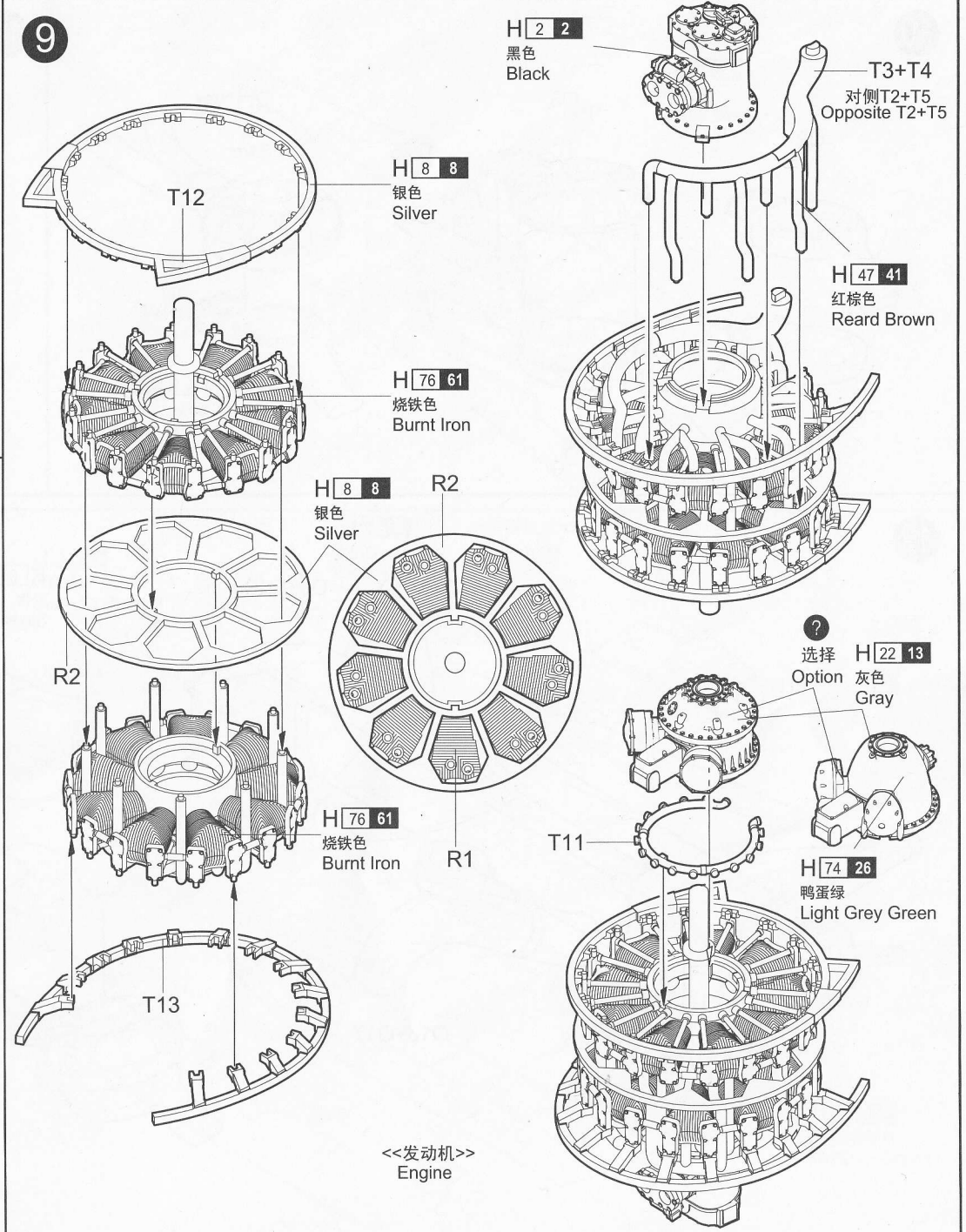

10

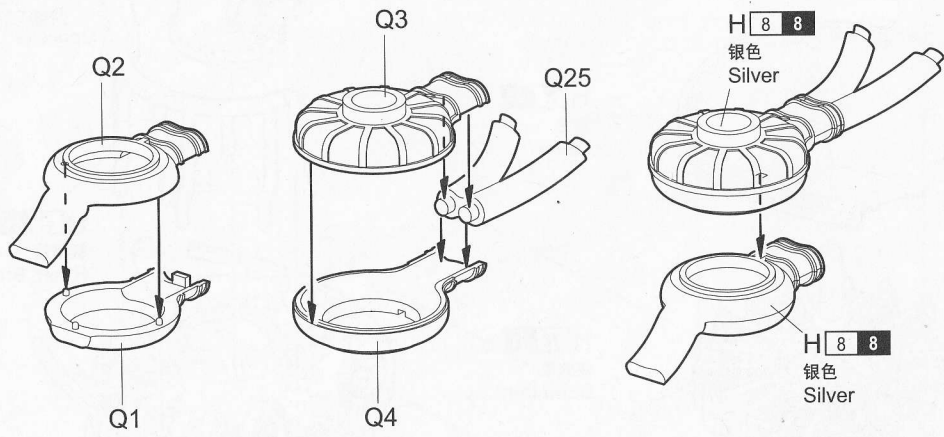

11

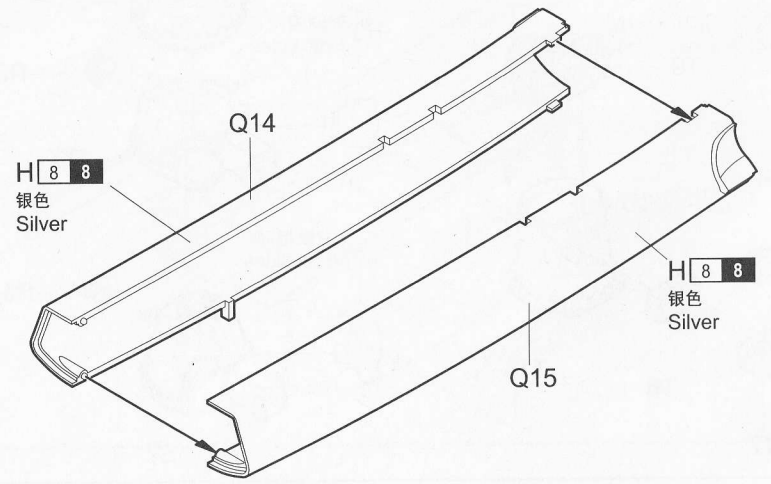

12

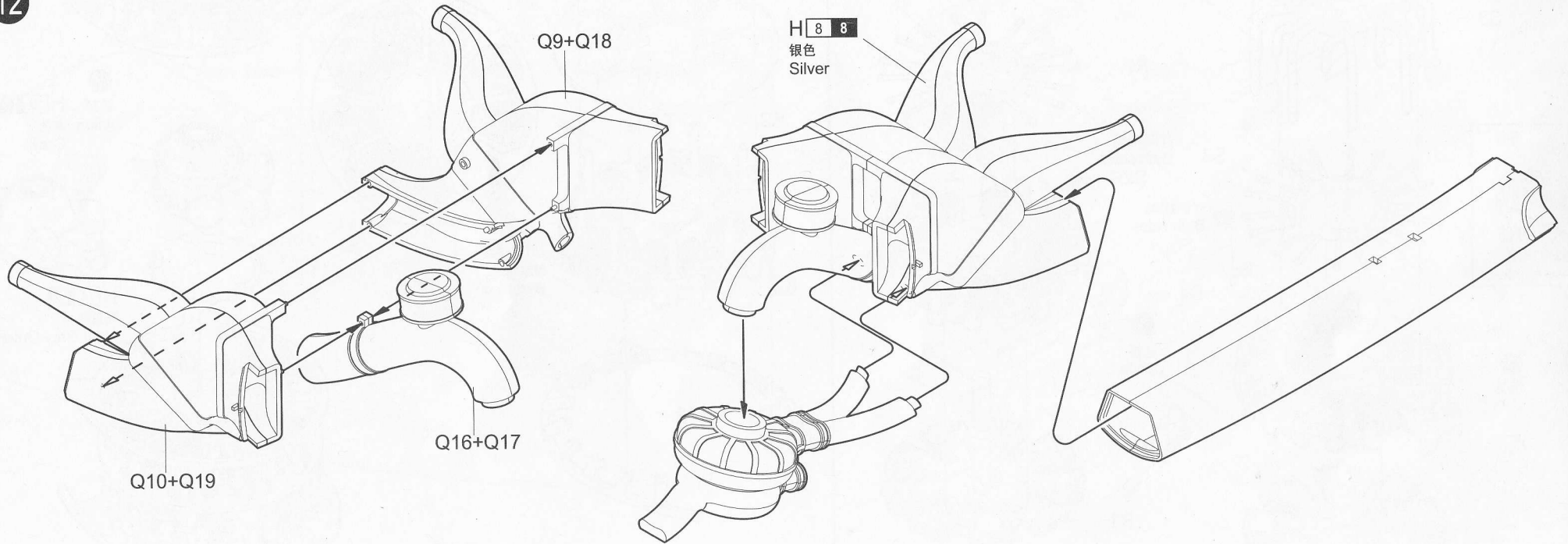

<<座舱>>
Cockpit

Q11+Q12

H 37 43

木棕色
Wood Brown

Q8

H 8 8

银色
Silver

PE4

PE4

Q36

短
Short

Q34

短
Short

Q35

长
long

长
long

H 2 2

黑色
Black

Q37

Q13

Q23

Q24

Q13

Q6

Q7

H 58 27

机体内部色
Interior Green

Q21

Q22

H 58 27

机体内部色
Interior Green

Q30+Q31

Q26

对侧Q27

Opposite Q27

PE6

H 8 8

银色
Silver

对侧Q33
Opposite Q33

Q32

15

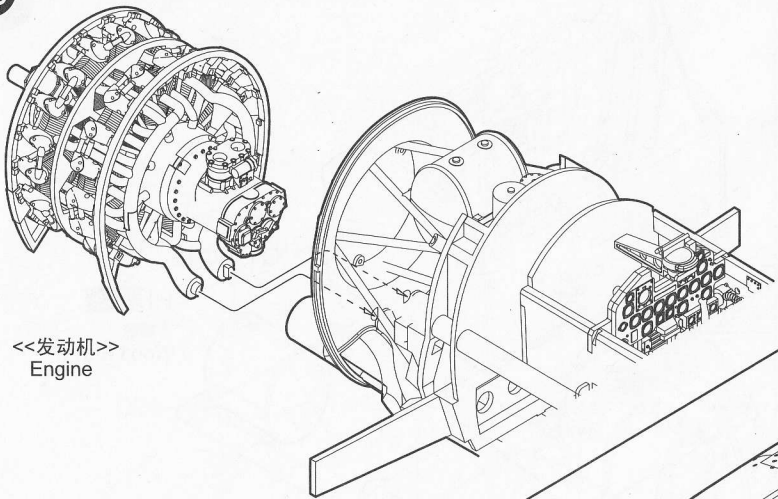

<<发动机>>
Engine

对侧Q28
Opposite Q28

Q29

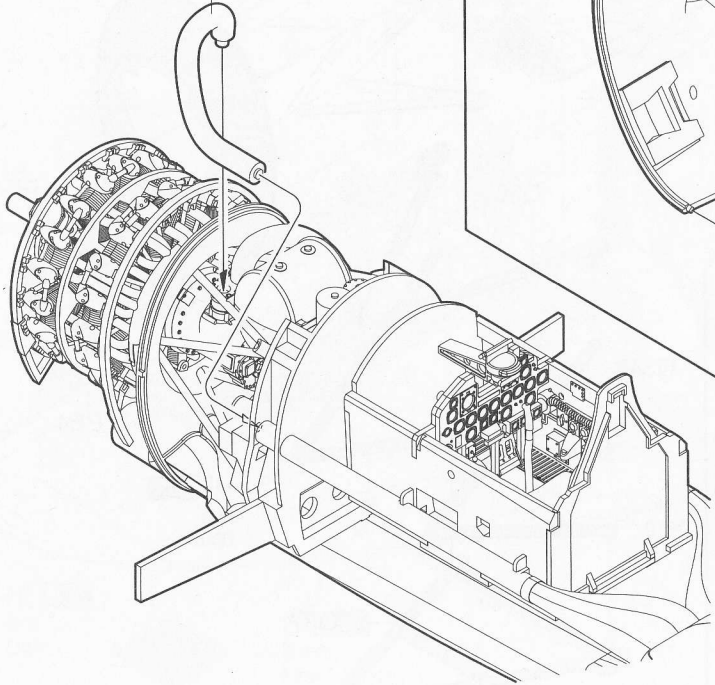

16

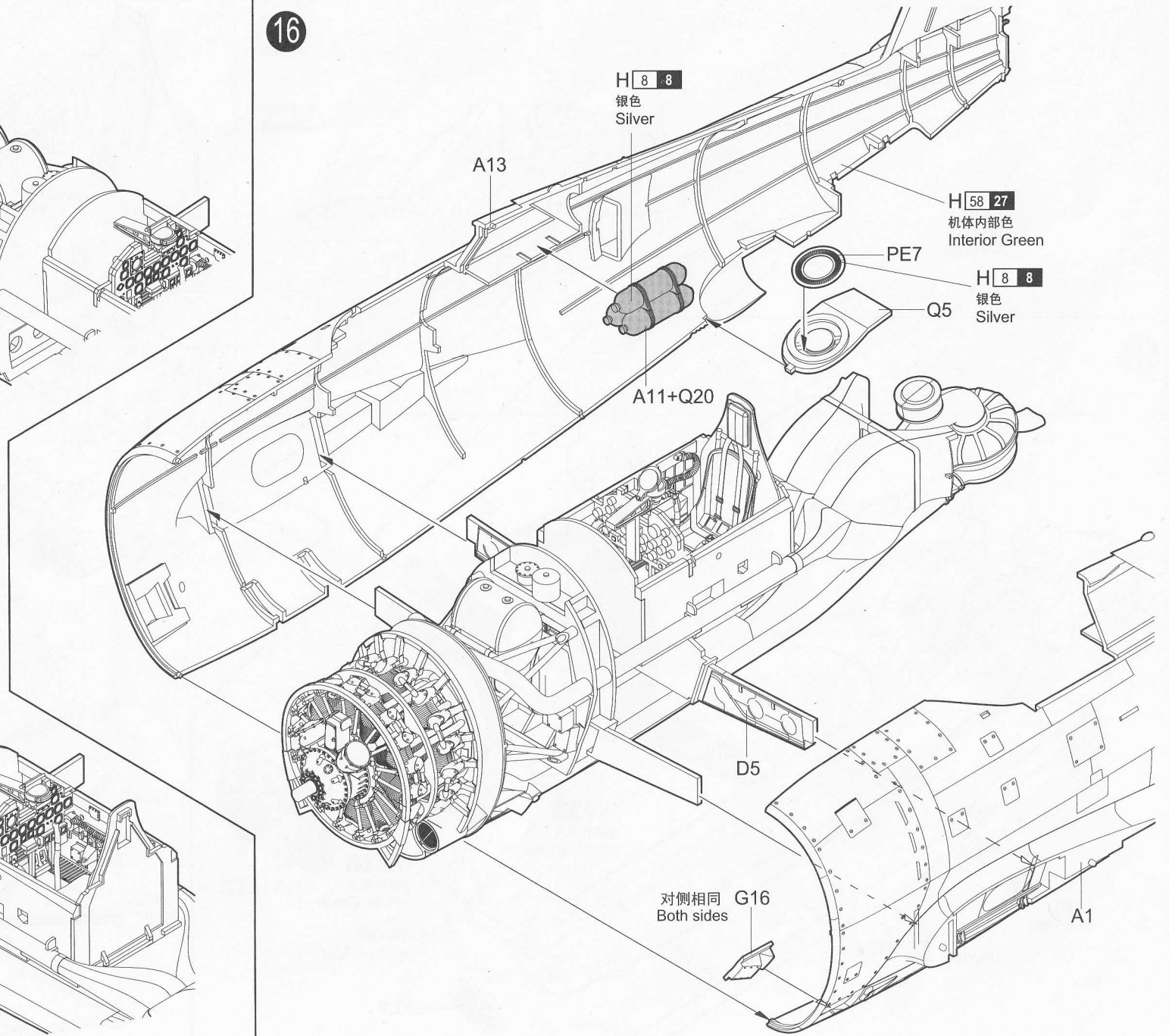

H 8 8
银色
Silver

A13

H 58 27
机体内部色
Interior Green

PE7

H 8 8
银色
Silver

Q5

A11+Q20

D5

对侧相同
Both sides

G16

A1

17

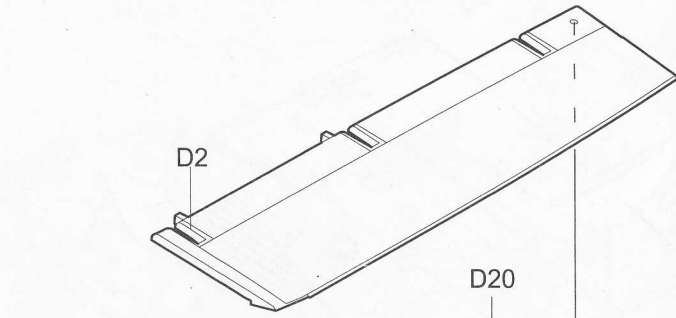
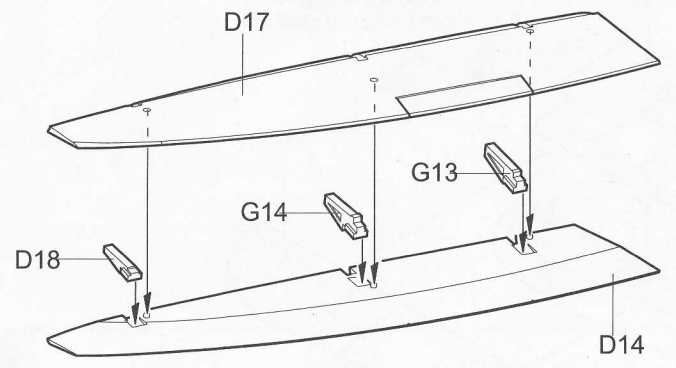

打开状态时装D25 D20
Attaching D25 & D20 when open

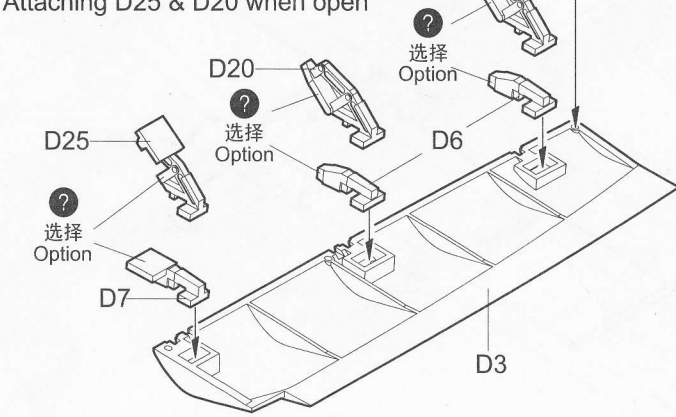

18

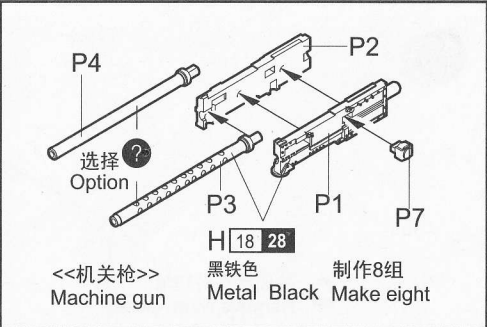
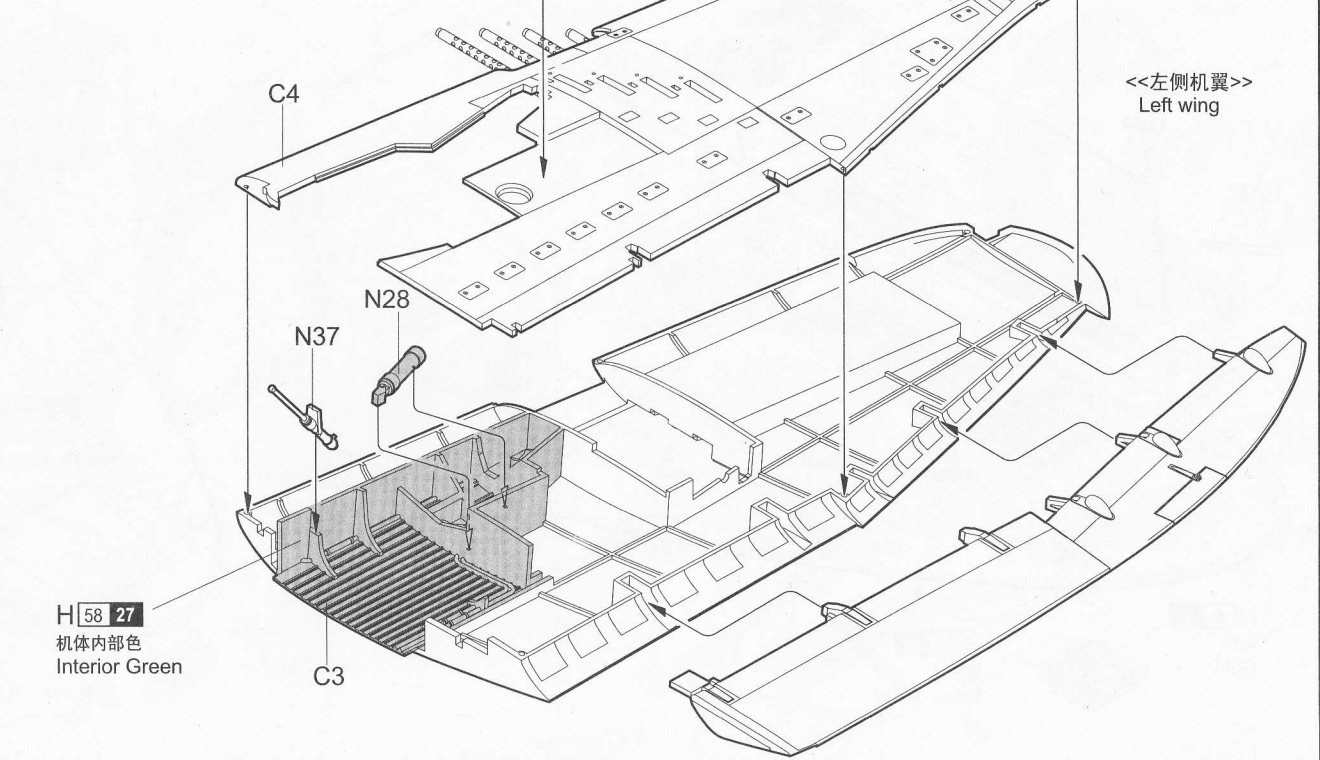
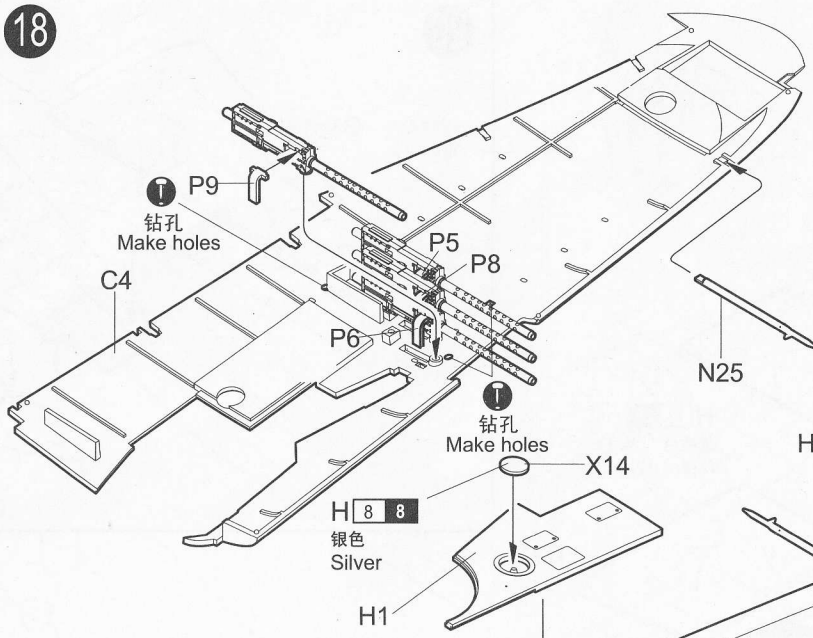

<<机关枪>>
Machine gun

H 18 28

黑铁色 Metal Black 制作8组 Make eight

<<左侧机翼>>
Left wing

H 58 27
机体内部色
Interior Green

19

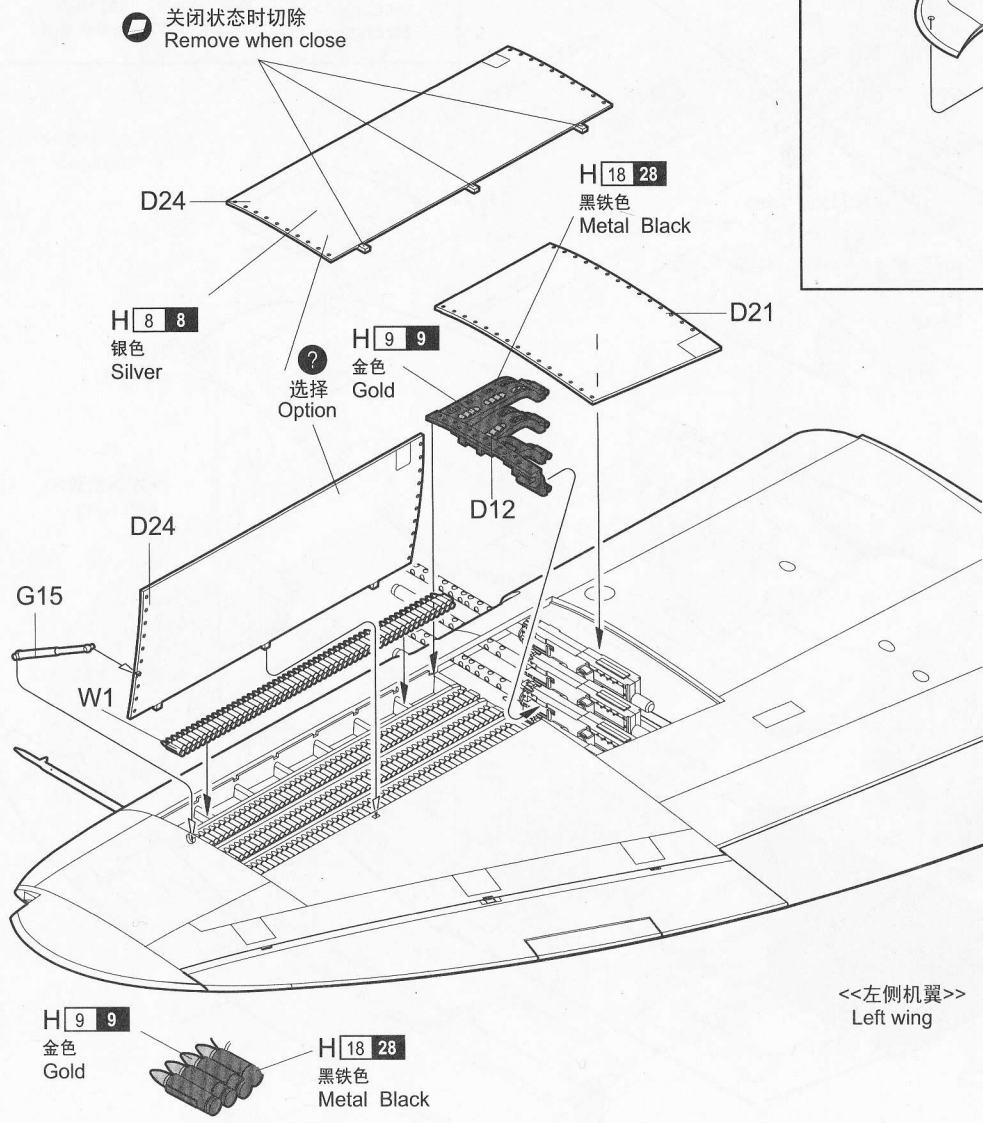

20

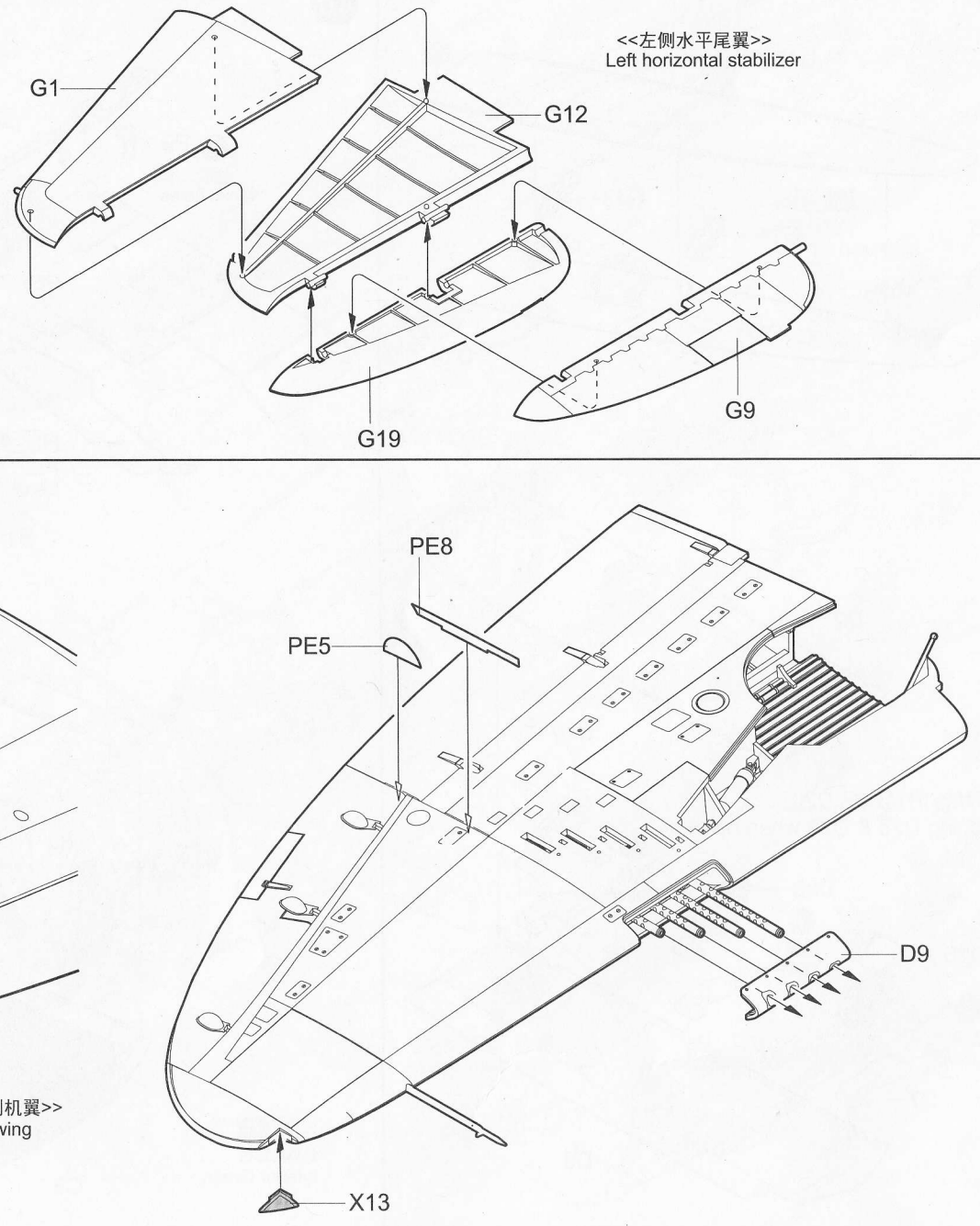

21

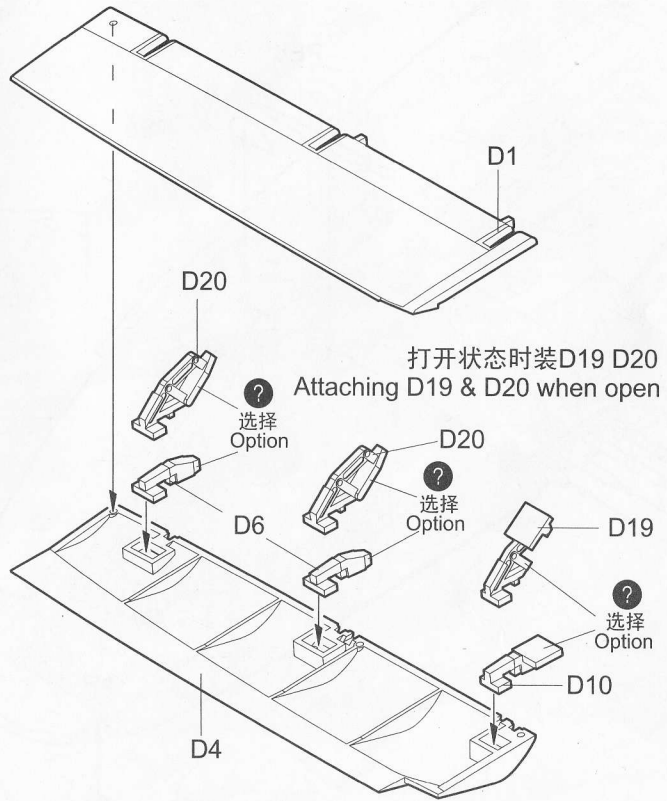
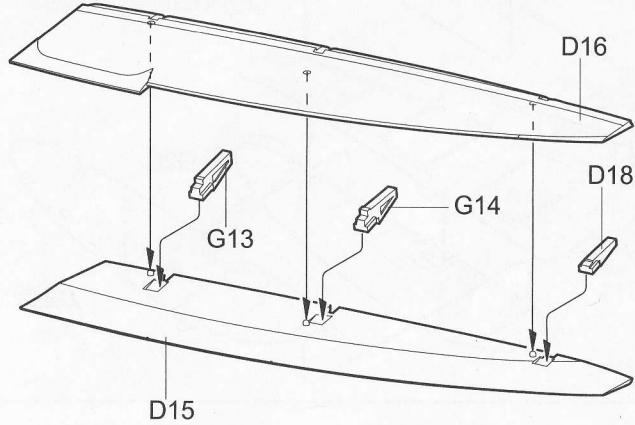

22

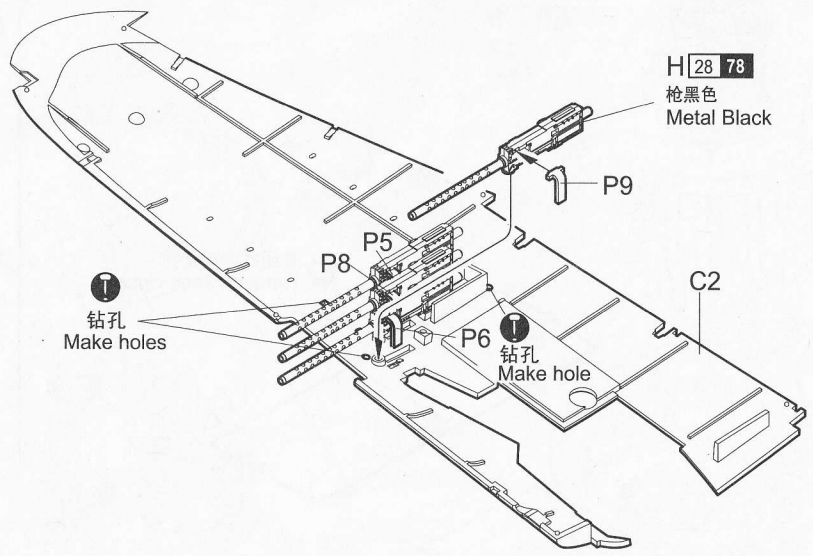

23

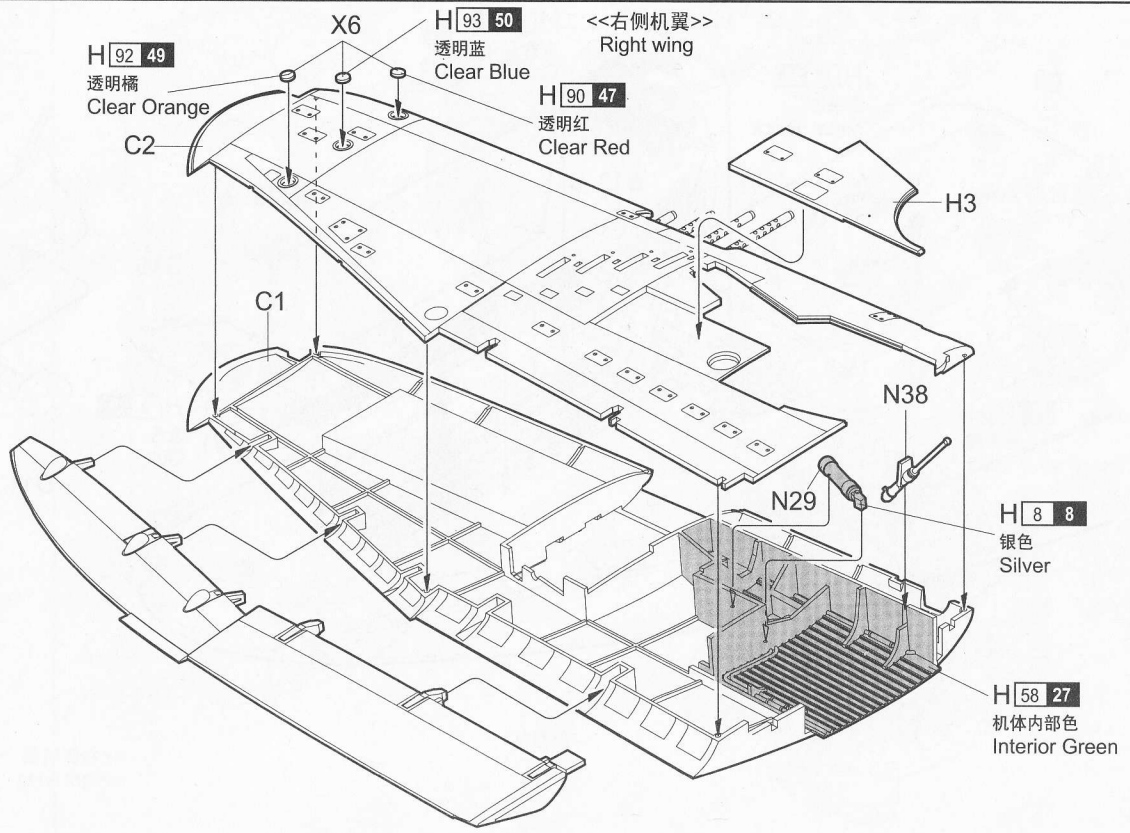

24

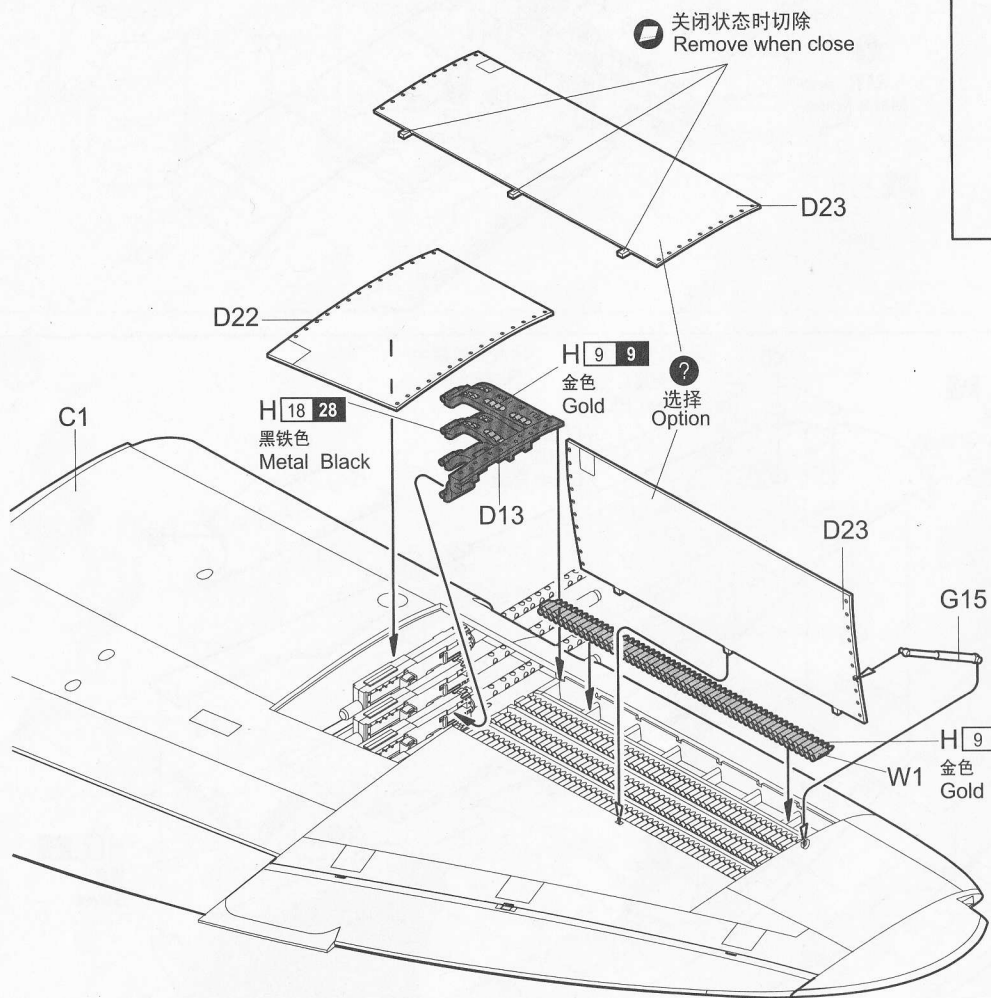

25

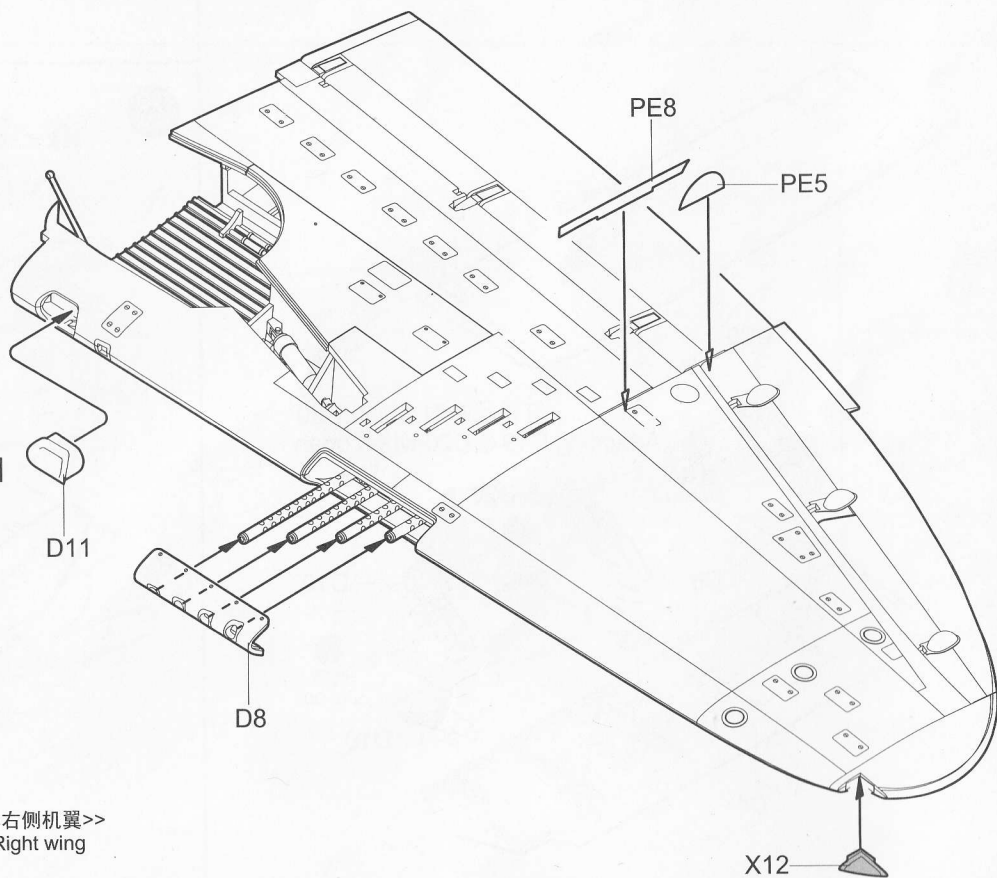
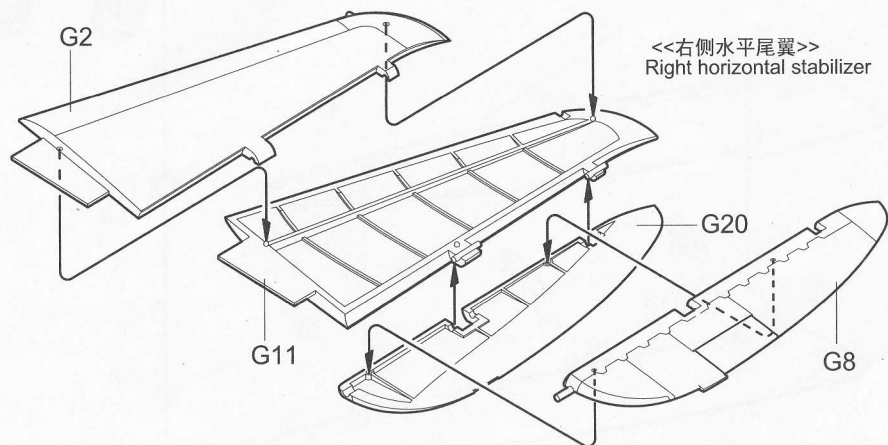

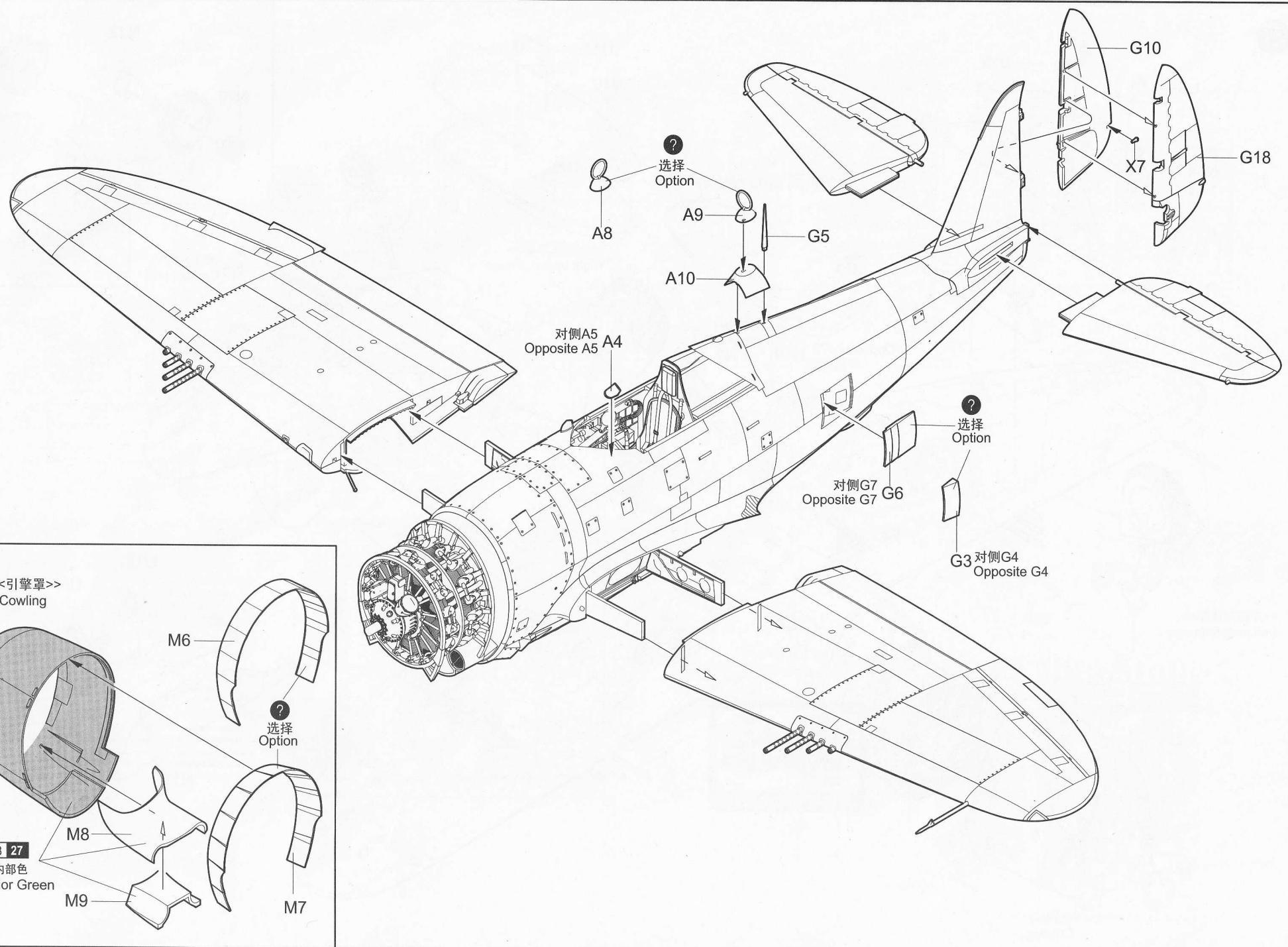

<<引擎罩>>
Cowling

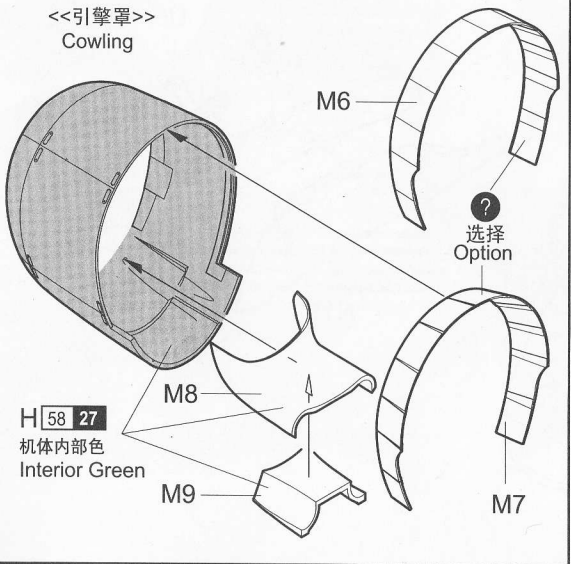

28

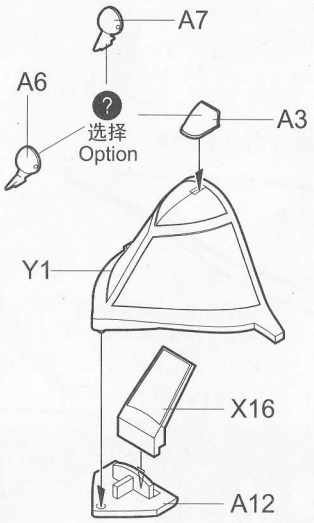
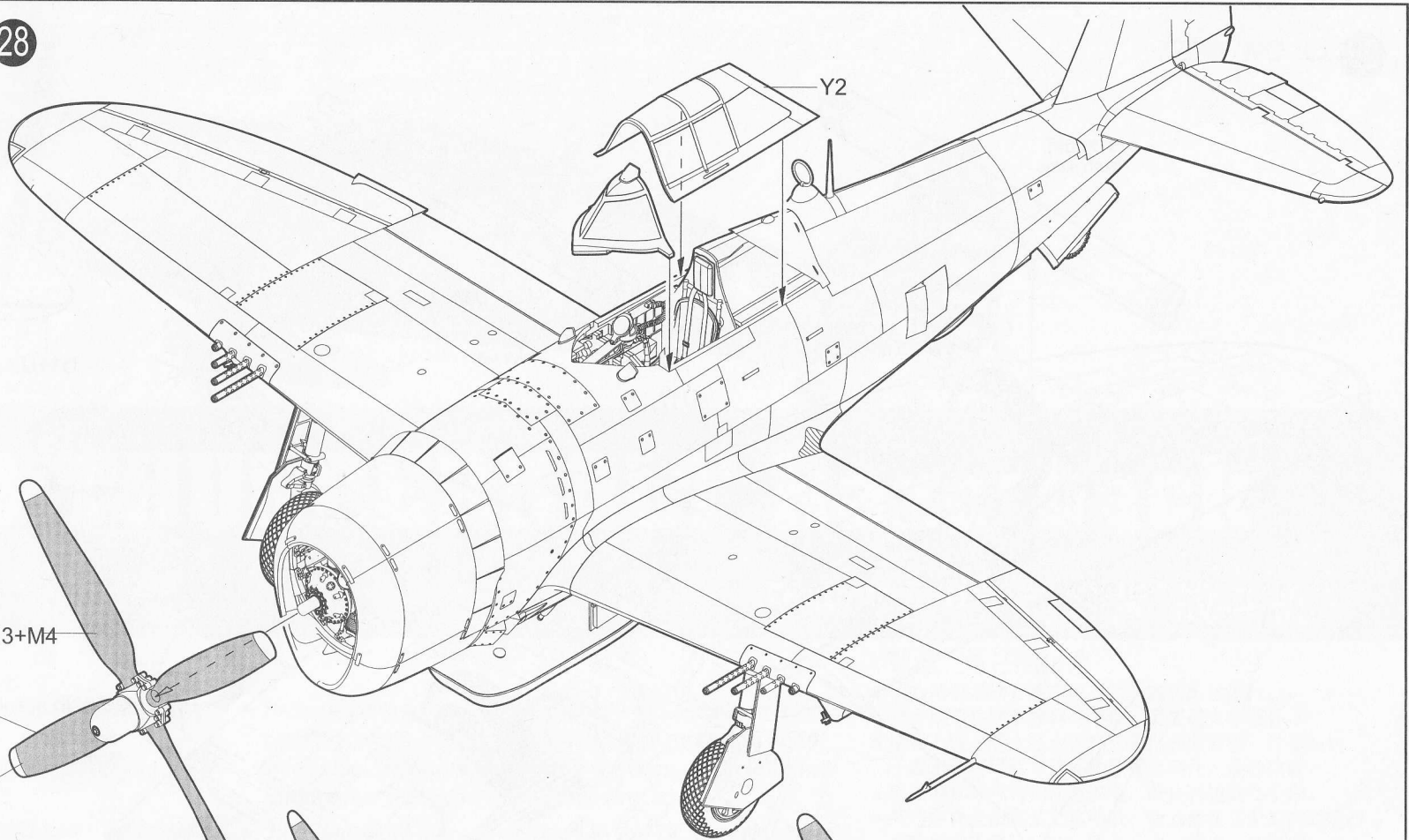

M3+M4

H 2 2
黑色
Black

?
选择
Option

M1

M5

H 329 329
黄色
Orange Yellow

?
选择
Option

M10

?
选择
Option

M2

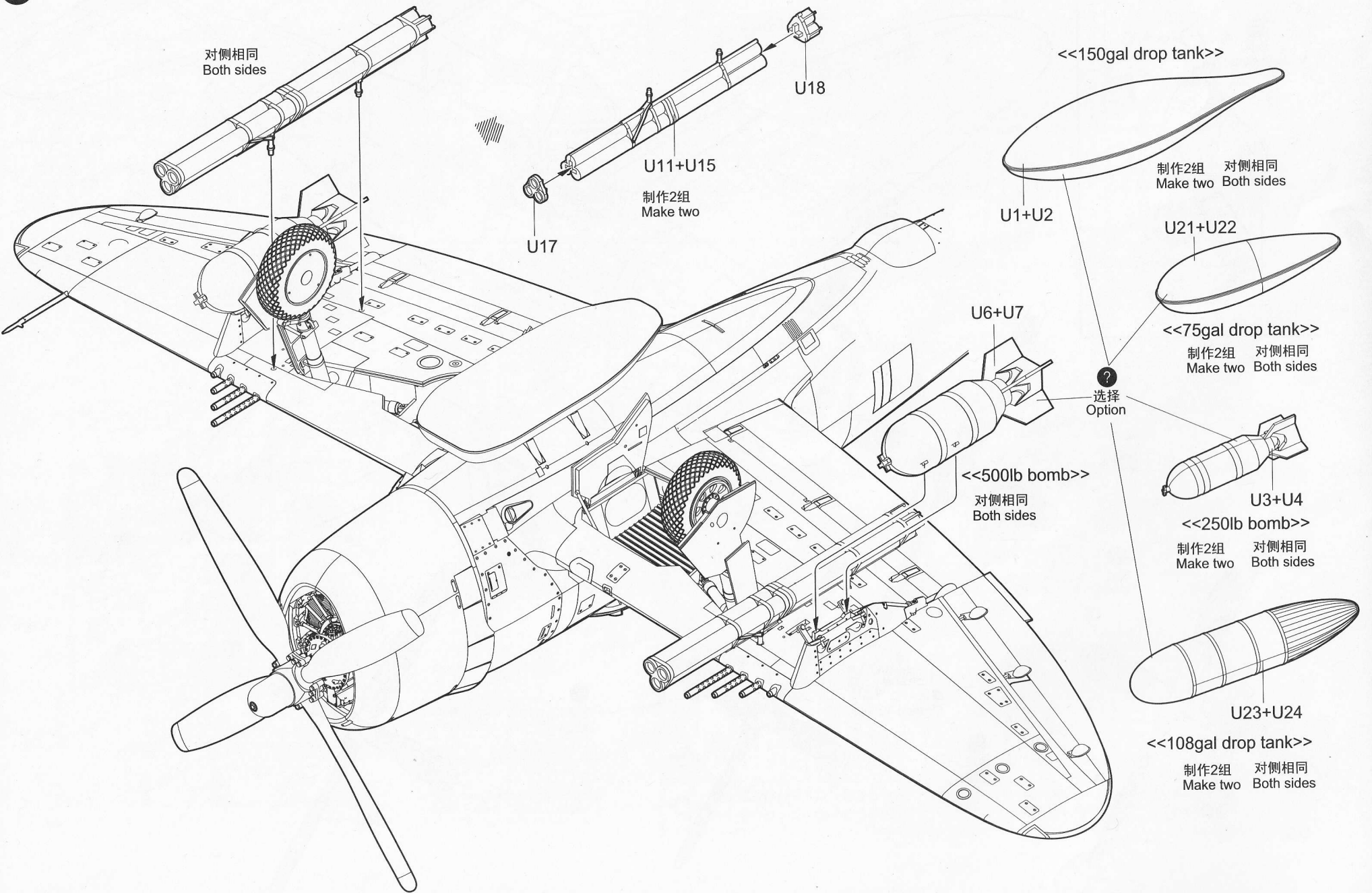

Painting & Marking guide

A P-47D, Flown by William D. Dunham, Southwest Pacific, 1943.

H[94]	透明绿	Clear Green	H[76 61]	烧铁色	Burnt Iron
H[8 8]	银色	Silver	H[119]	沙黄色	RLM79 Sand Yellow
H[58 27]	机体内部色	Interior Green	H[77 137]	胎黑色	Tire Black
H[12 33]	亚光黑	Flat black	H[304 304]	橄榄色	Olive Drab
H[90 47]	透明红	Clear Red	H[329]	黄色	Orange Yellow

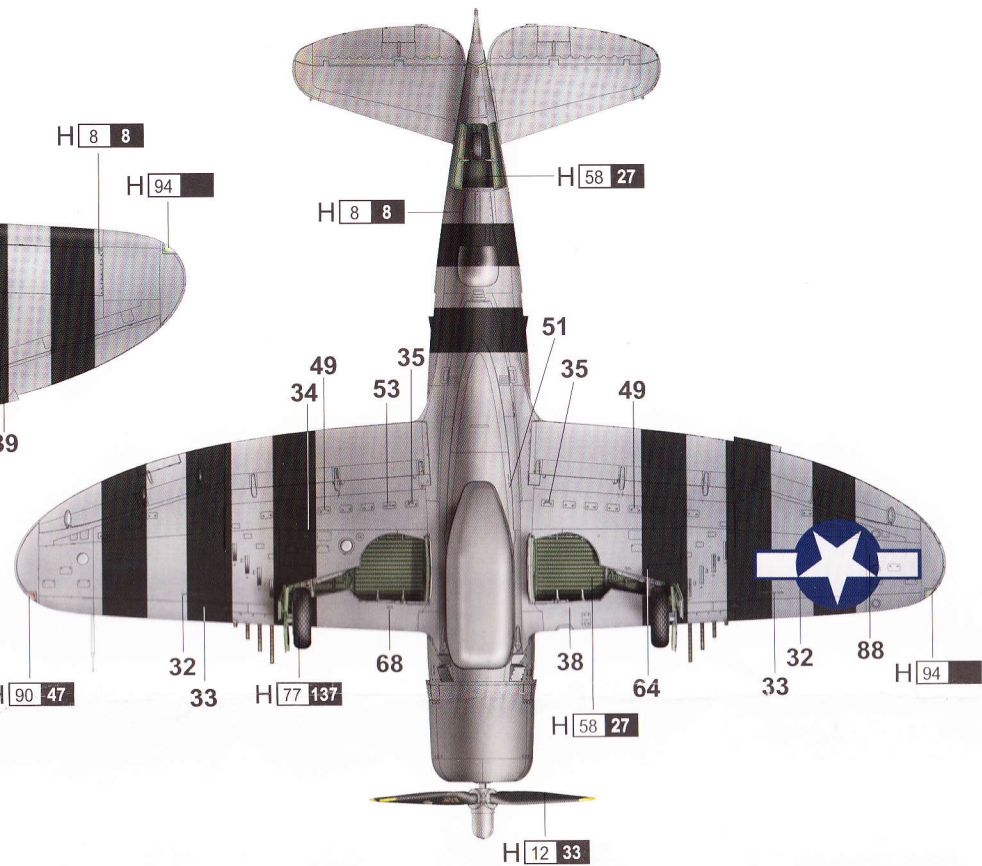
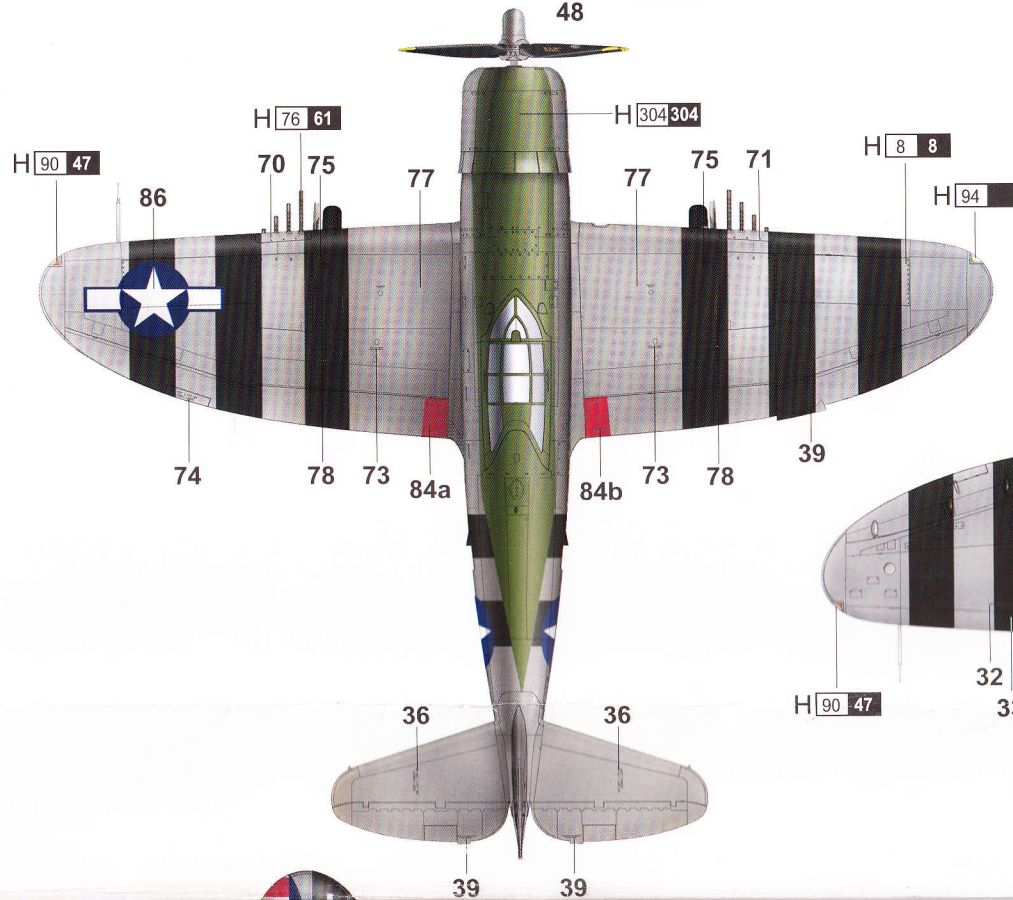
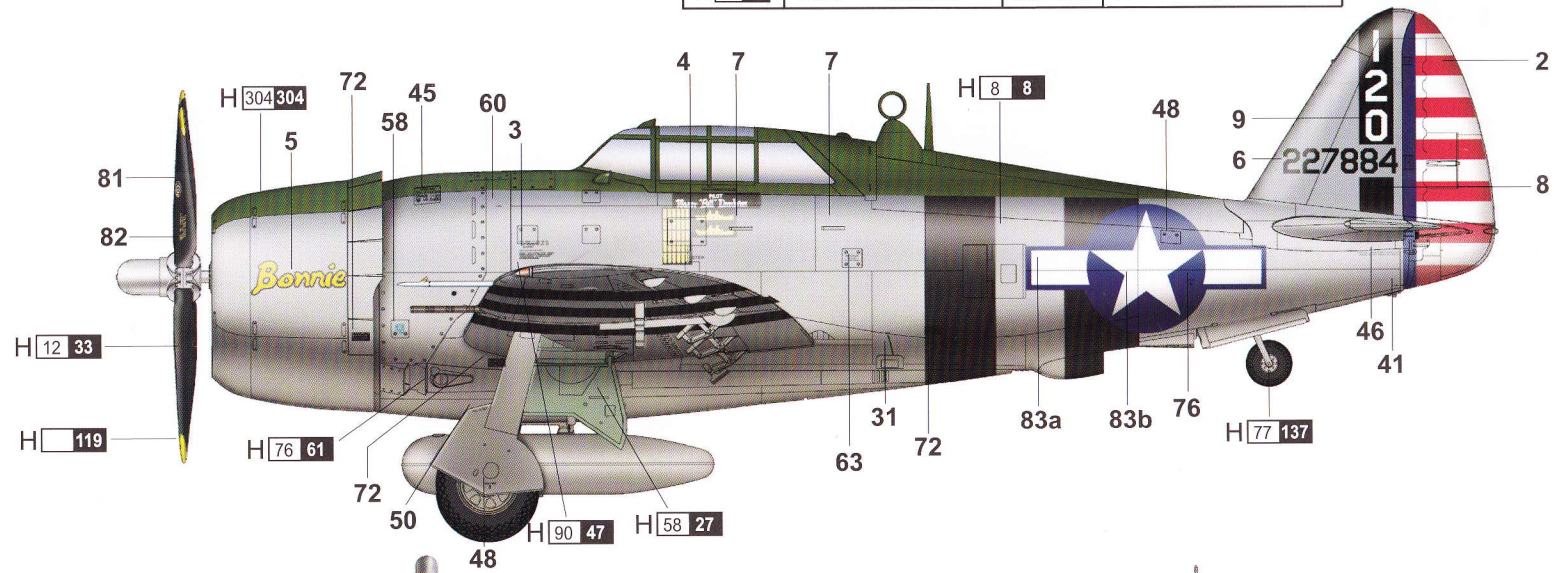

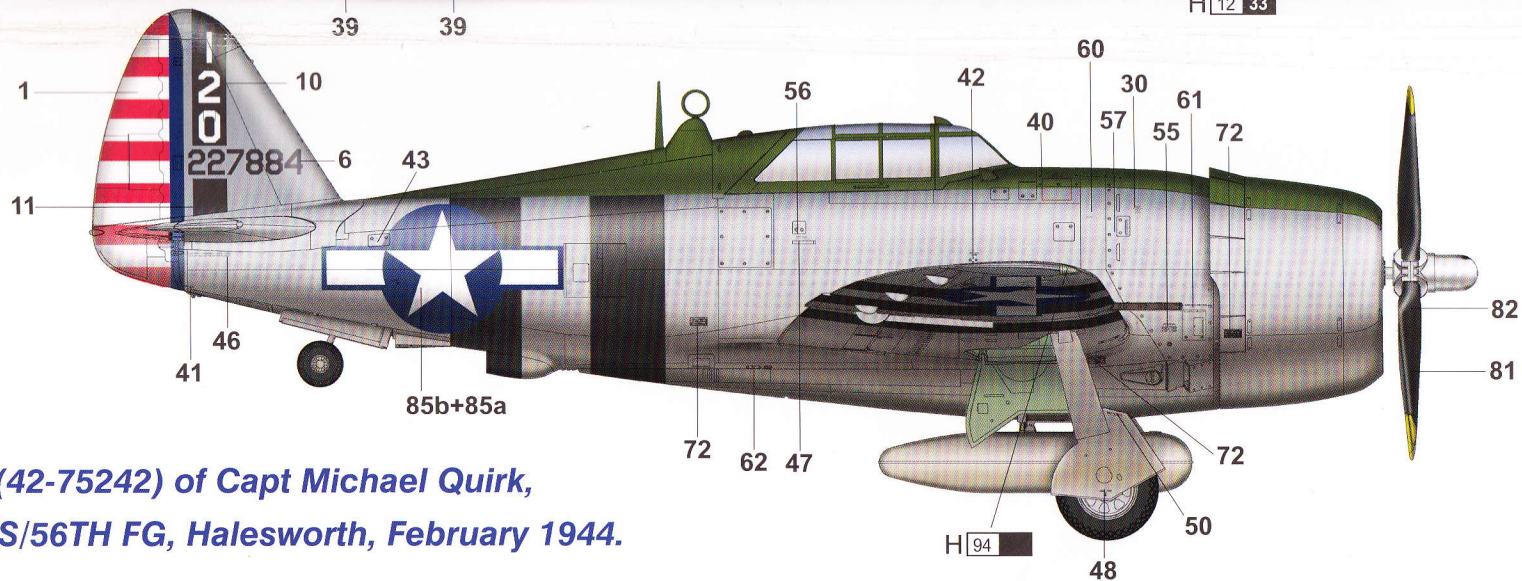

B P-47D (42-75242) of Capt Michael Quirk,
62nd FS/56TH FG, Halesworth, February 1944.

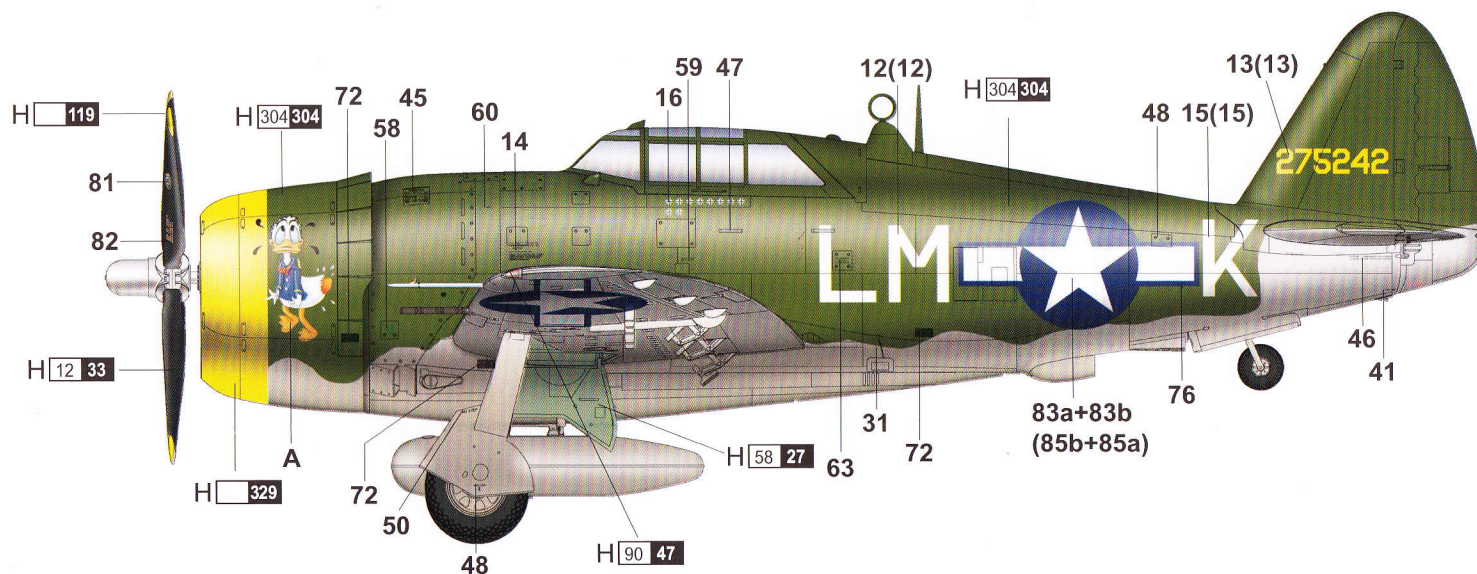

H AQUEOUS HOBBY COLOR

Mr. COLOR

使用 MR.HOBBY 涂料 Mr. Color Used

02262 1/32 P-47D "Razorbacks" Fighter