

P-47D THUNDERBOLT "BUBBLE TOP"

1:32 SCALE

P-47D 雷电“水泡座舱”战斗机

READ BEFORE ASSEMBLY

- Study and understand these instructions thoroughly before beginning assembly. Make sure all parts are included by comparing them to those shown on pages 2 & 3 of these instructions.
- Remove parts from sprues as needed, and trim excess with a hobby knife. Be careful not to lose small parts.
- Remove photo-etch parts from sprue as needed using a hobby knife or photo etch cutter.
- Apply cement to photo etch parts as shown on instructions. Applying too much cement will restrict the operation of these

movable parts. Apply cement carefully! Removed photo etch parts can have sharp edges. Take care when handling these to avoid injury.

- Apply decals to necessary parts prior to assembly.
- Additional tools recommended(not included):Sprue cutter, Long nose pliers, hobby knife, file, tweezers, pin vise, scissors, cement, sandpaper, soft cloth, glue and paint.
- Keep all parts out of reach of children, as they pose a choking hazard. Discard all unnecessary bags and sprues when model is completed to avoid accidental injury.

装配之前仔细阅读

- 小心用模型锉刀锉平所有零件表面的注射浇口。
- 小心用刀片切下蚀刻片零件，不要遗失小零件。
- 用强力快干胶水粘合蚀刻片零件和金属轴。过量的快干胶水使用可能导致可动零件会粘住，小心涂胶。
- 取蚀刻片时应特别注意安全，防止利边划伤手指。
- 某些零件表面需贴水上贴纸，请选择在装配的同时进行。
- 推荐模型工具(自备)：胶水，水口剪刀，长咀钳，刀片，锉刀，镊子钳，钻，剪刀，瞬间快干胶。
- 软布同砂纸同时也应该是必备工具。
- 请使用塑料胶水和油漆，模型内不含。
- 谨防小孩吸吮塑料零件，或者将塑料袋套在头上，制作时应将套材远离小孩接触。

水贴纸的使用:

1. 从水贴上剪下印花;
2. 将印花放入温水中浸10秒, 然后放在干净布上。
3. 拿着印花纸板将印花移到模型上;
4. 手指蘸水将印花移到适当的位置;
5. 用软布轻压印花直至水干, 气泡消失。

DECAL APPLICATION

1. Cut off decal from sheet.
2. Dip the decal in tepid water 40°C for about 10 sec. and place on a clean cloth.
3. Hold the backing sheet edge and slide decal onto the model.
4. Move decal into position by wetting decal with finger.
5. Press decal gently down with a soft cloth until excess water and air bubbles are gone.



cyanocrylate glue
使用强力胶



weight
配重



make hole
钻孔



cut / remove
切除



option
选择



no cement
不涂胶水



decal
贴纸



bend
弯曲



file / sand
锉平

部品图
Parts

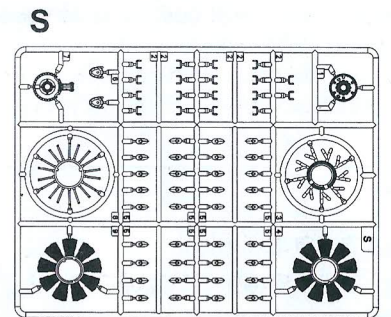
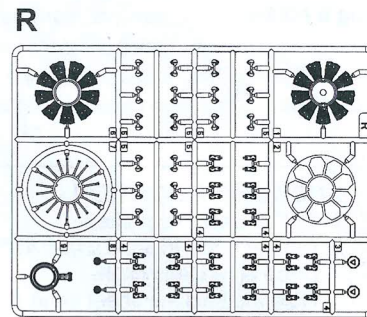
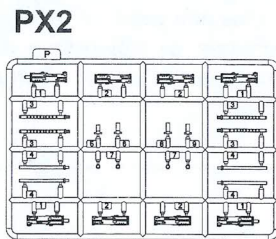
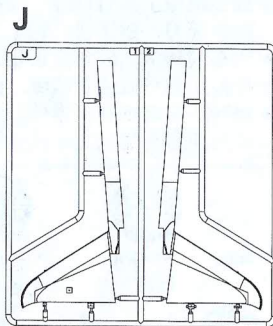
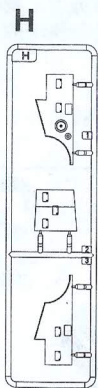
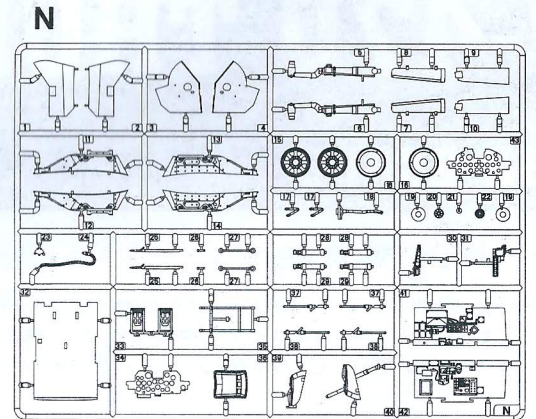
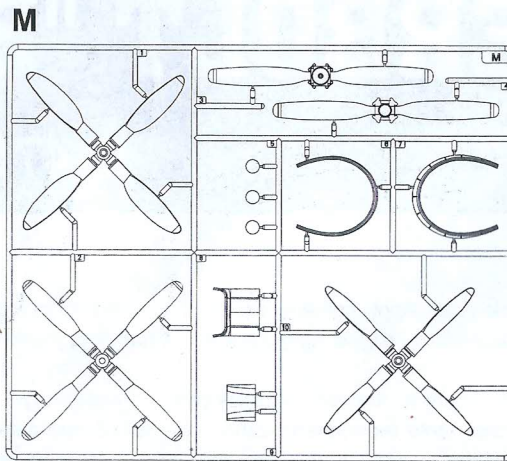
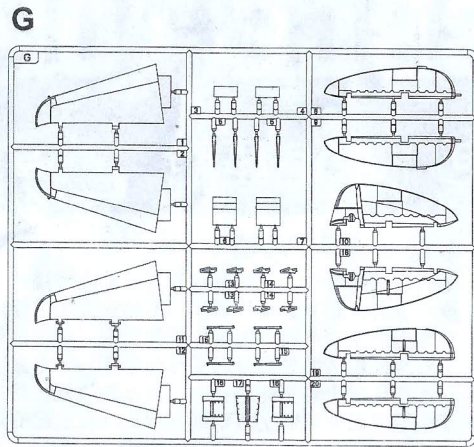
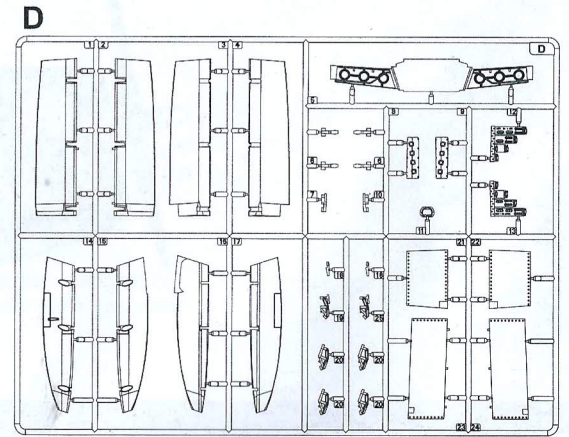
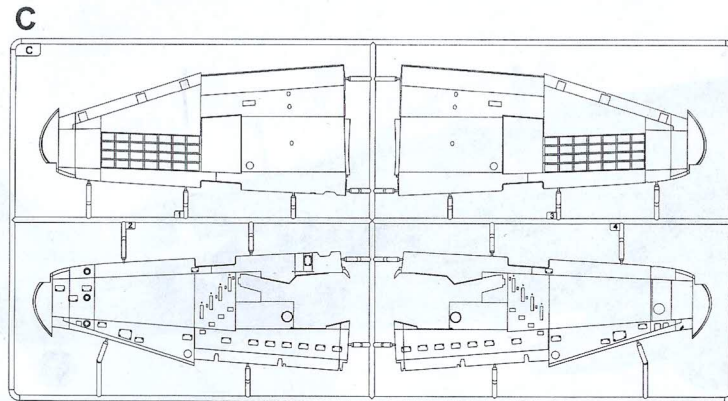
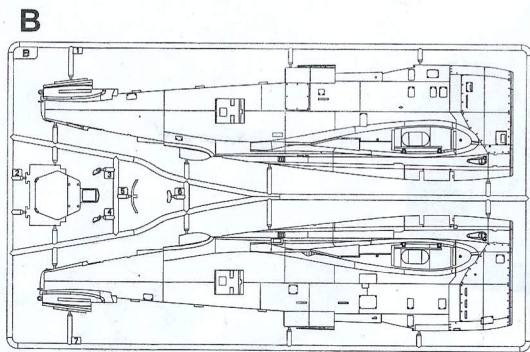

部品图

Parts

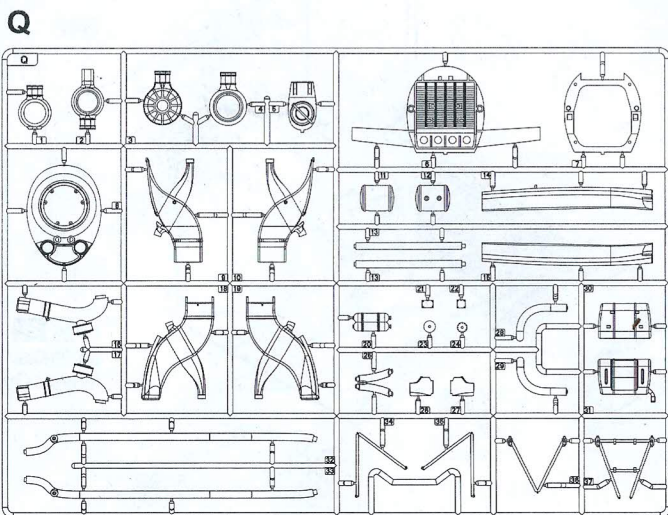

UX2

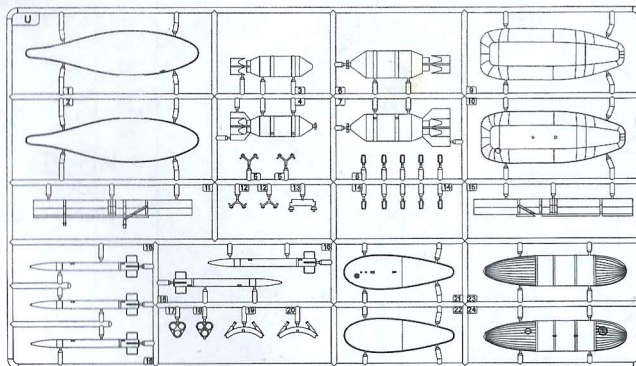

T

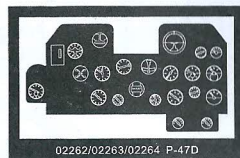
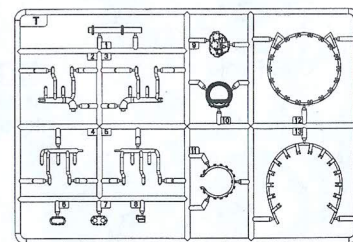

<<菲林片>>
Film Part:

Photo etched parts(PE)

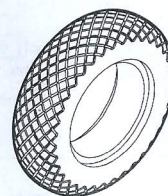

<<主轮胎>>
Main tyre

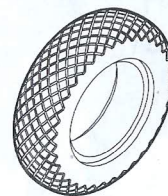

<<尾轮>>
Tail tyre

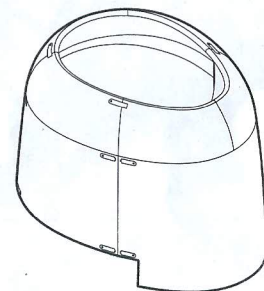

<<引擎罩>>
Cowling

X

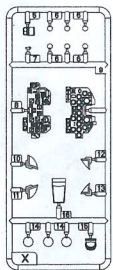

Z

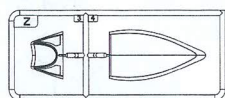

W

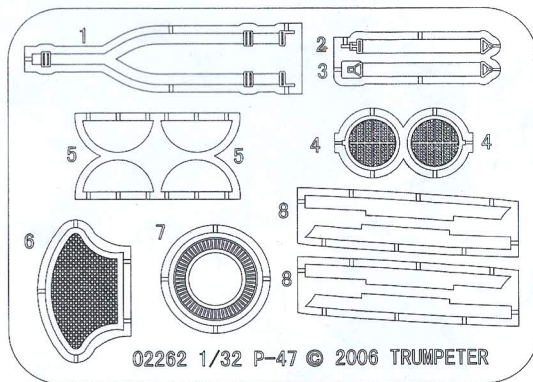
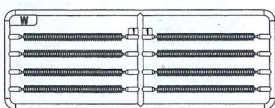

<<水贴 A>>
Decal A



<<水贴>>
Decal

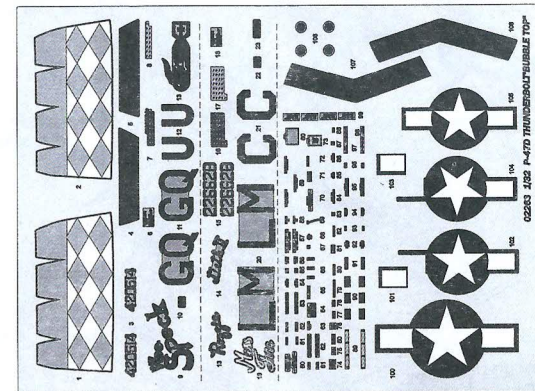

不用的部件: N43 U11 U15 U17 U18 X9 X10 X11 X16
unused parts:

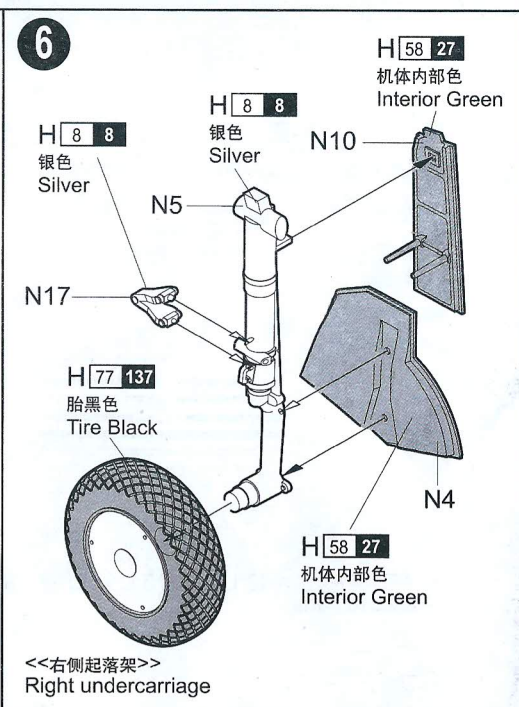
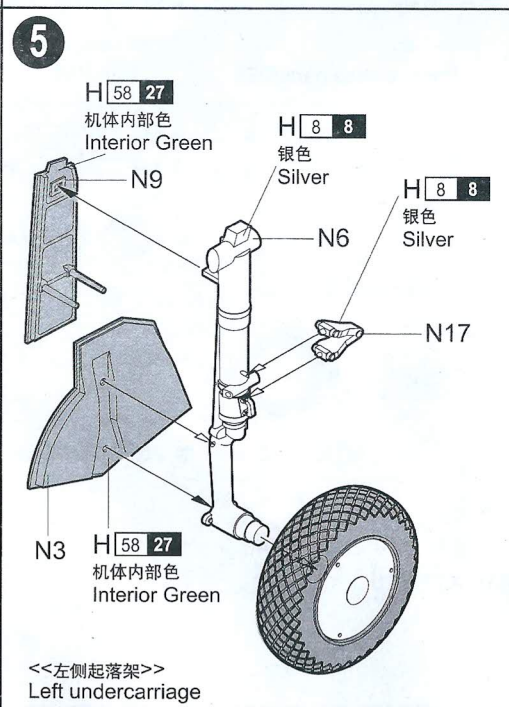
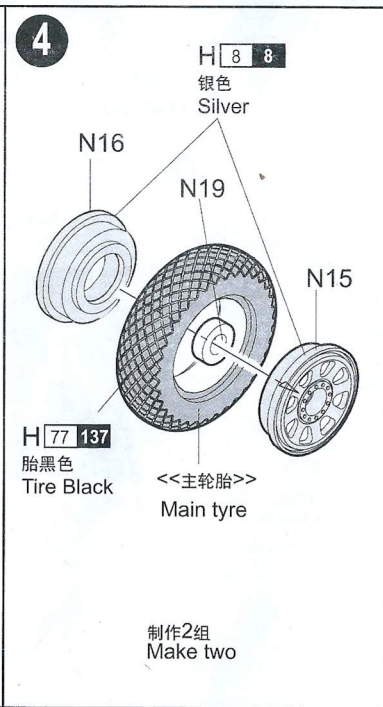
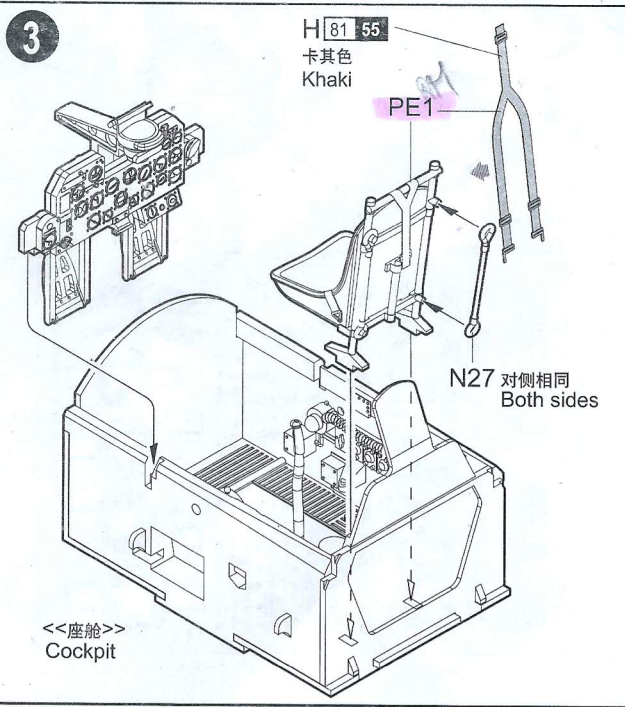
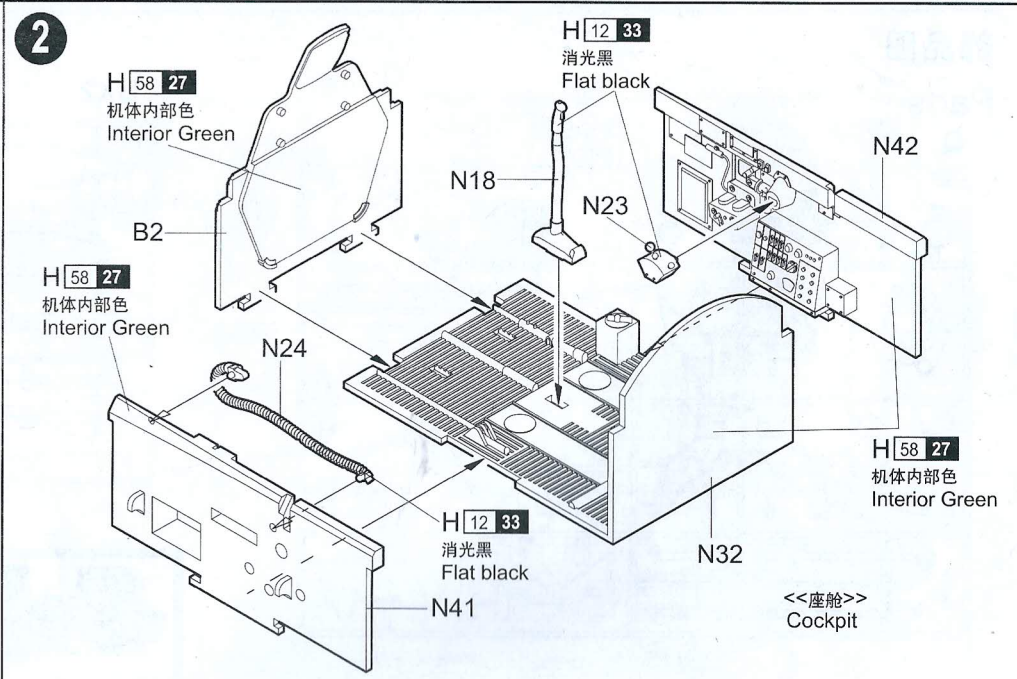
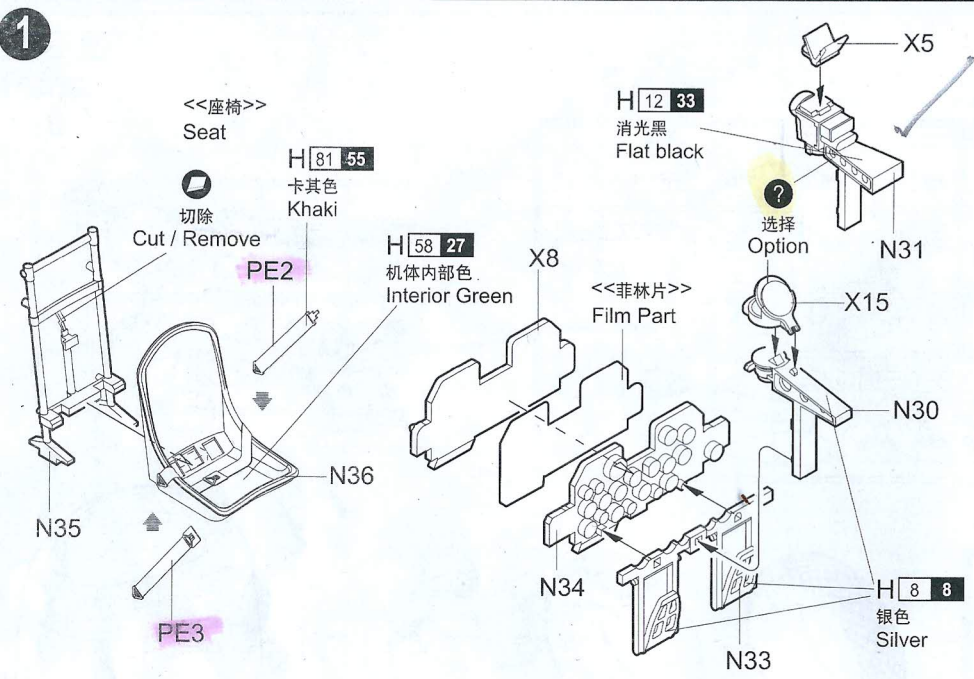

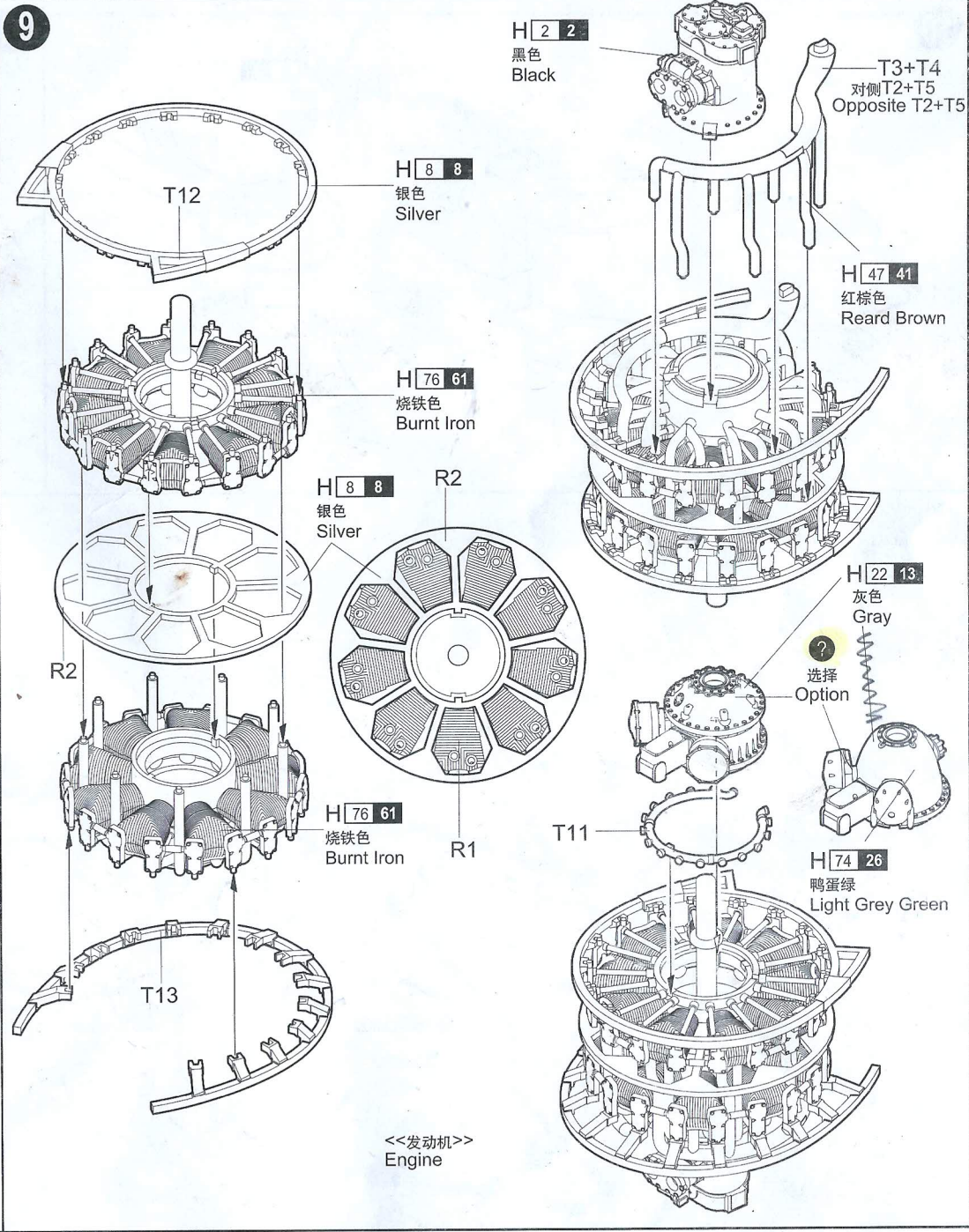
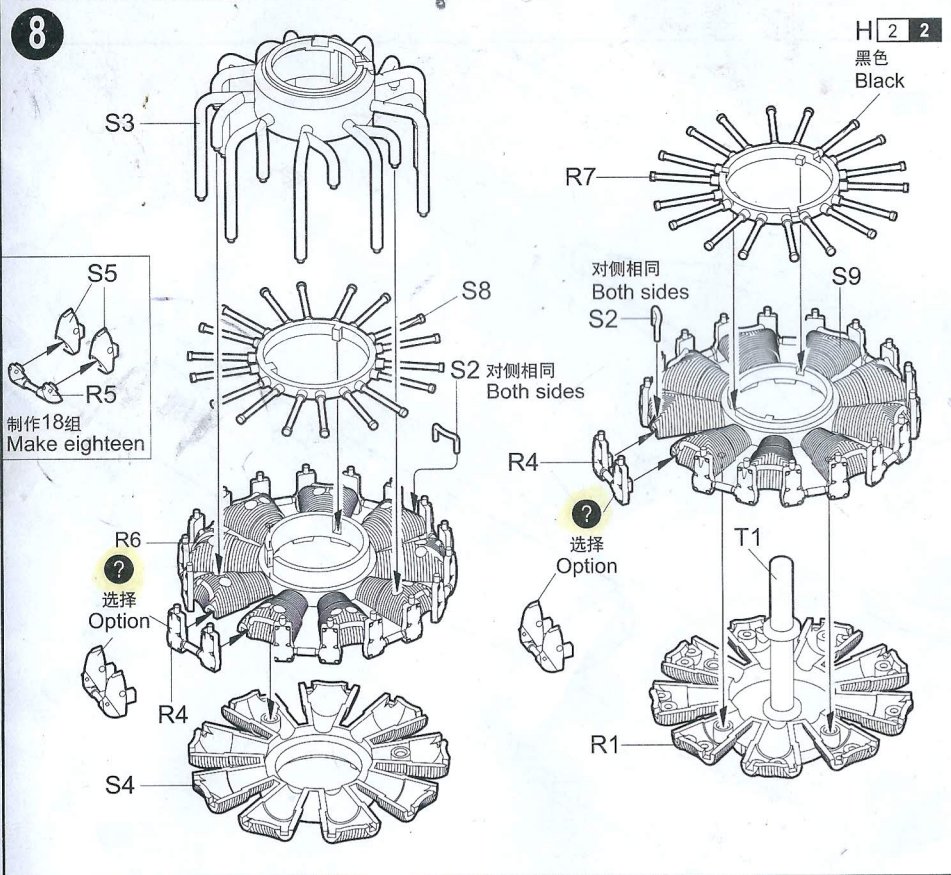
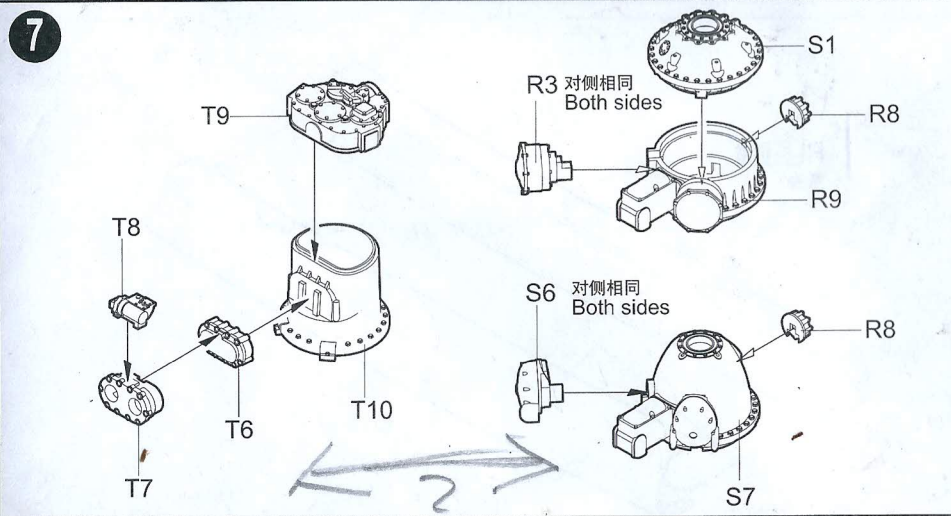

10

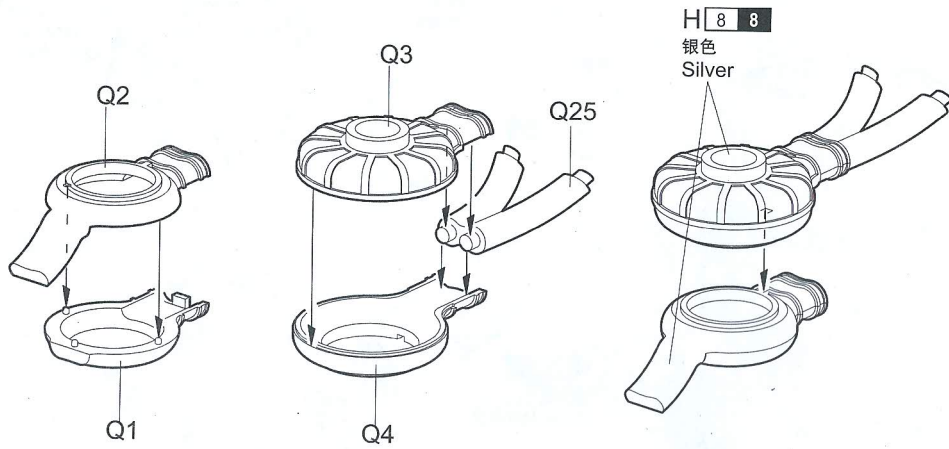

11

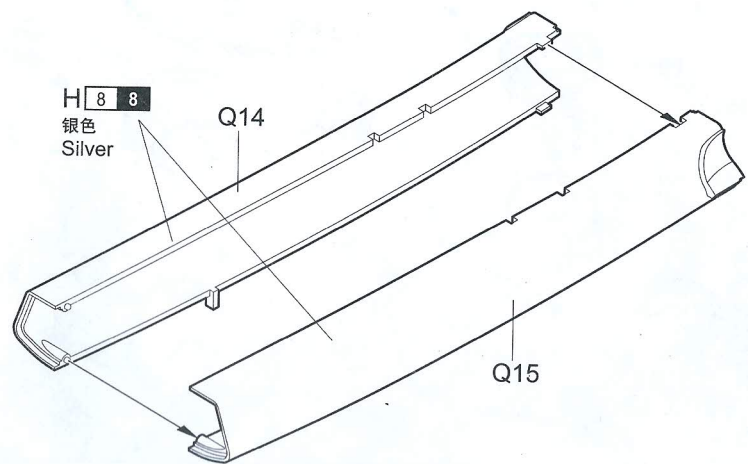

12

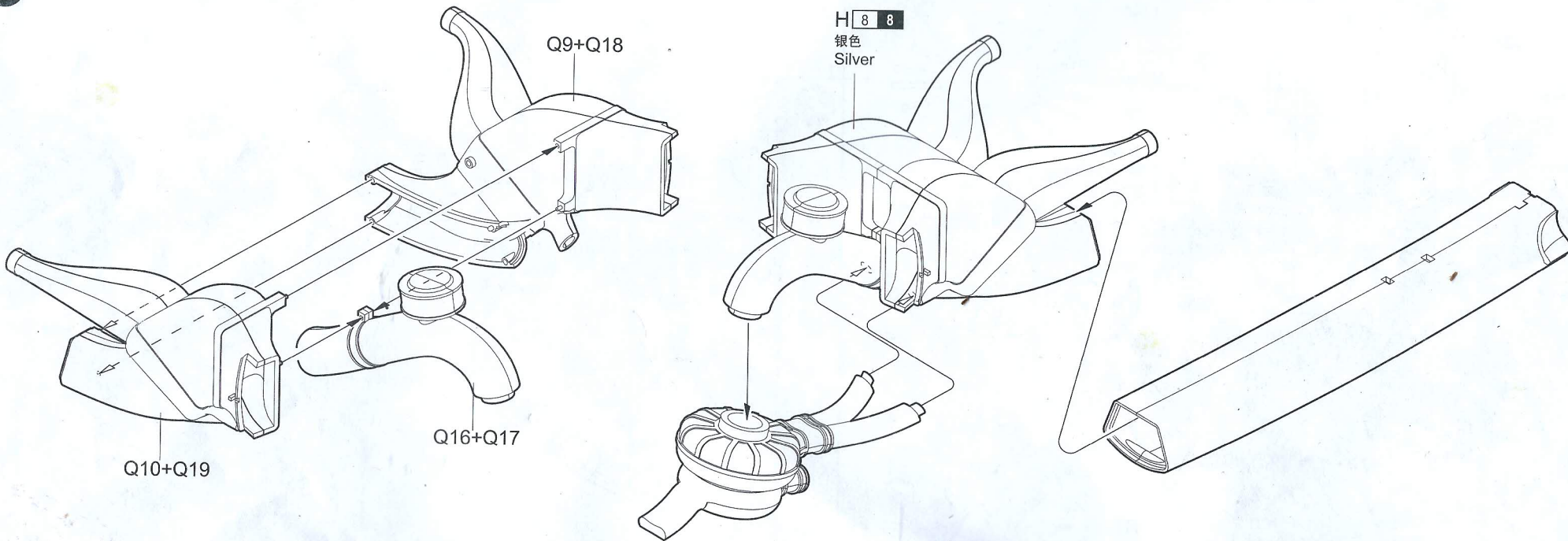

13

14

<<座舱>>
Cockpit

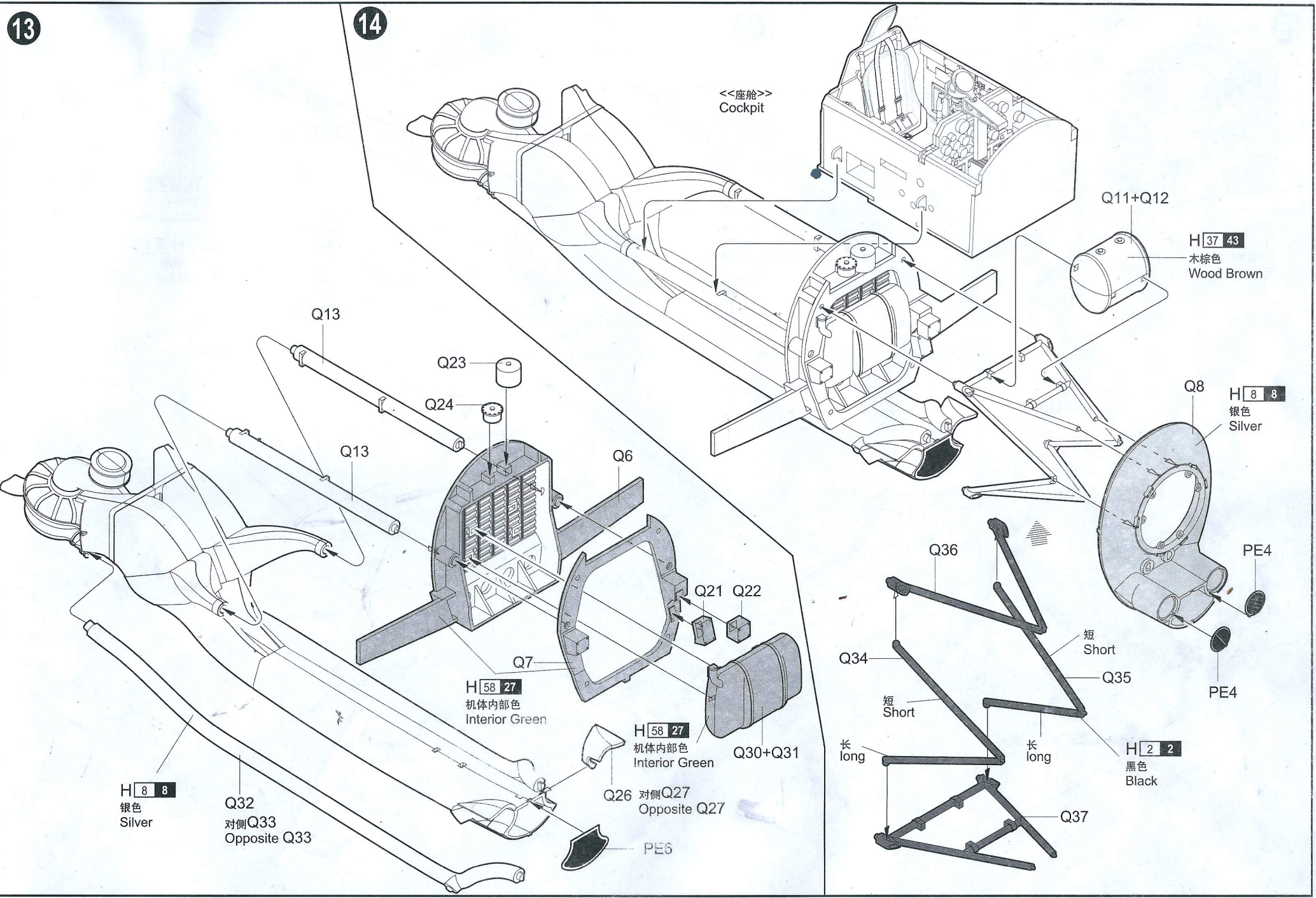

H 37 43
木棕色
Wood Brown

H 8 8
银色
Silver

PE4

PE4

H 2 2
黑色
Black

H 58 27
机体内部色
Interior Green

H 58 27
机体内部色
Interior Green

H 8 8
银色
Silver

Q32
对侧Q33
Opposite Q33

Q26 对侧Q27
Opposite Q27

短 Short

短 Short

短 Short

长 long

长 long

Q37

15

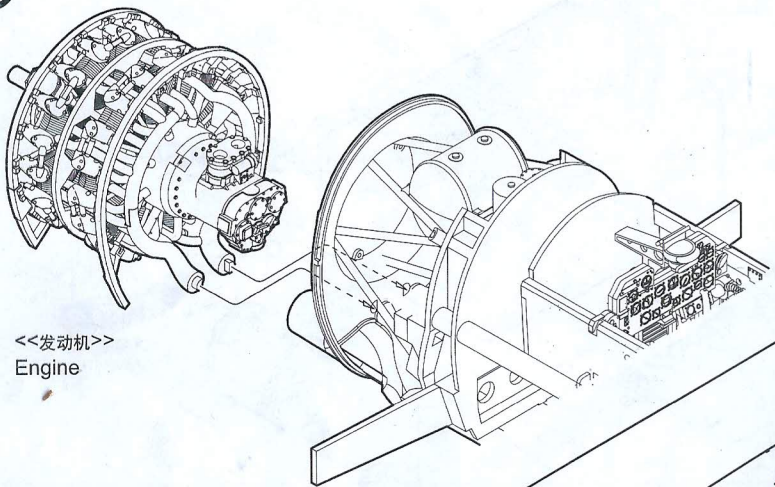

<<发动机>>
Engine

Q29 对侧 Q28
Opposite Q28

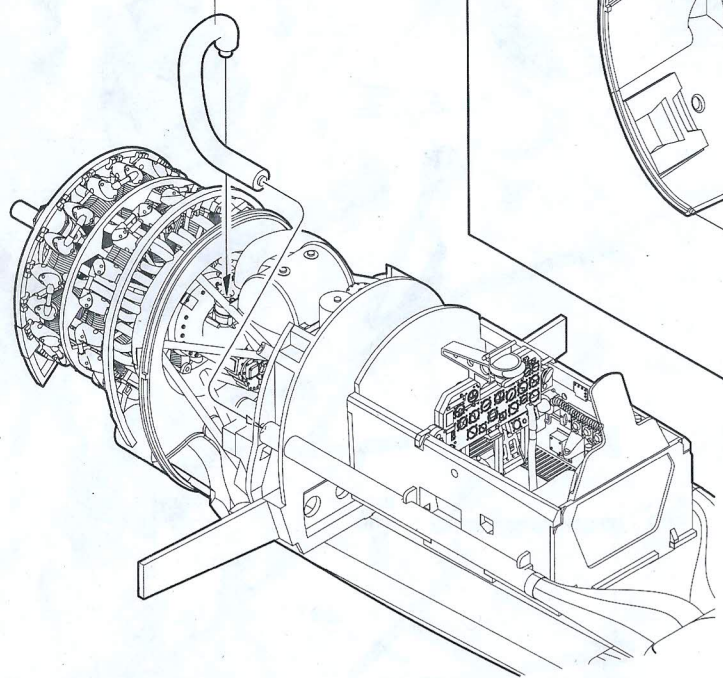

16

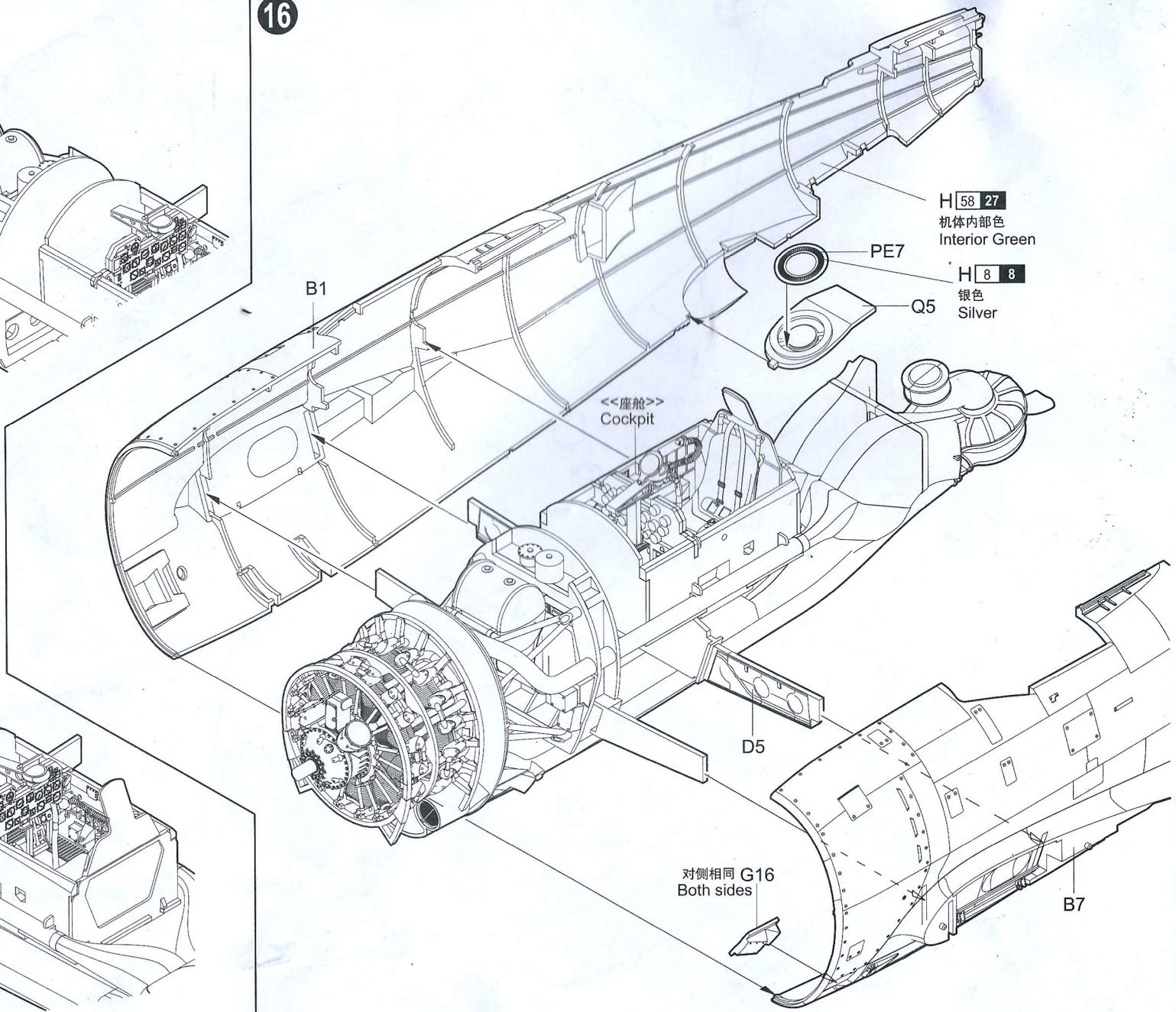

H 58 27
机体内部色
Interior Green

H 8 8
银色
Silver

<<座舱>>
Cockpit

对侧相同 G16
Both sides

17

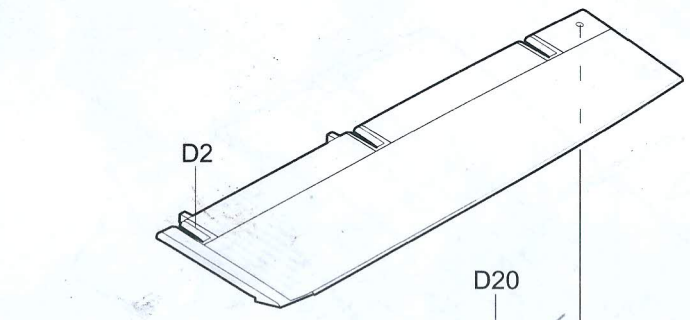
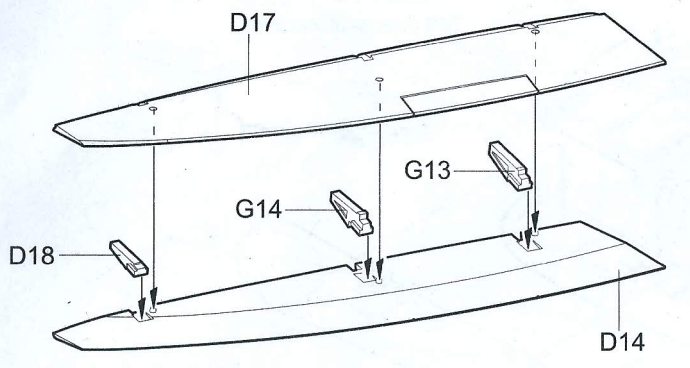

打开状态时装D25 D20
Attaching D25 & D20 when open

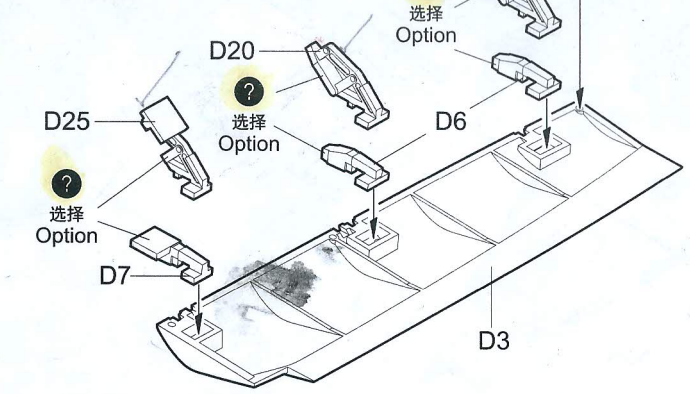

18

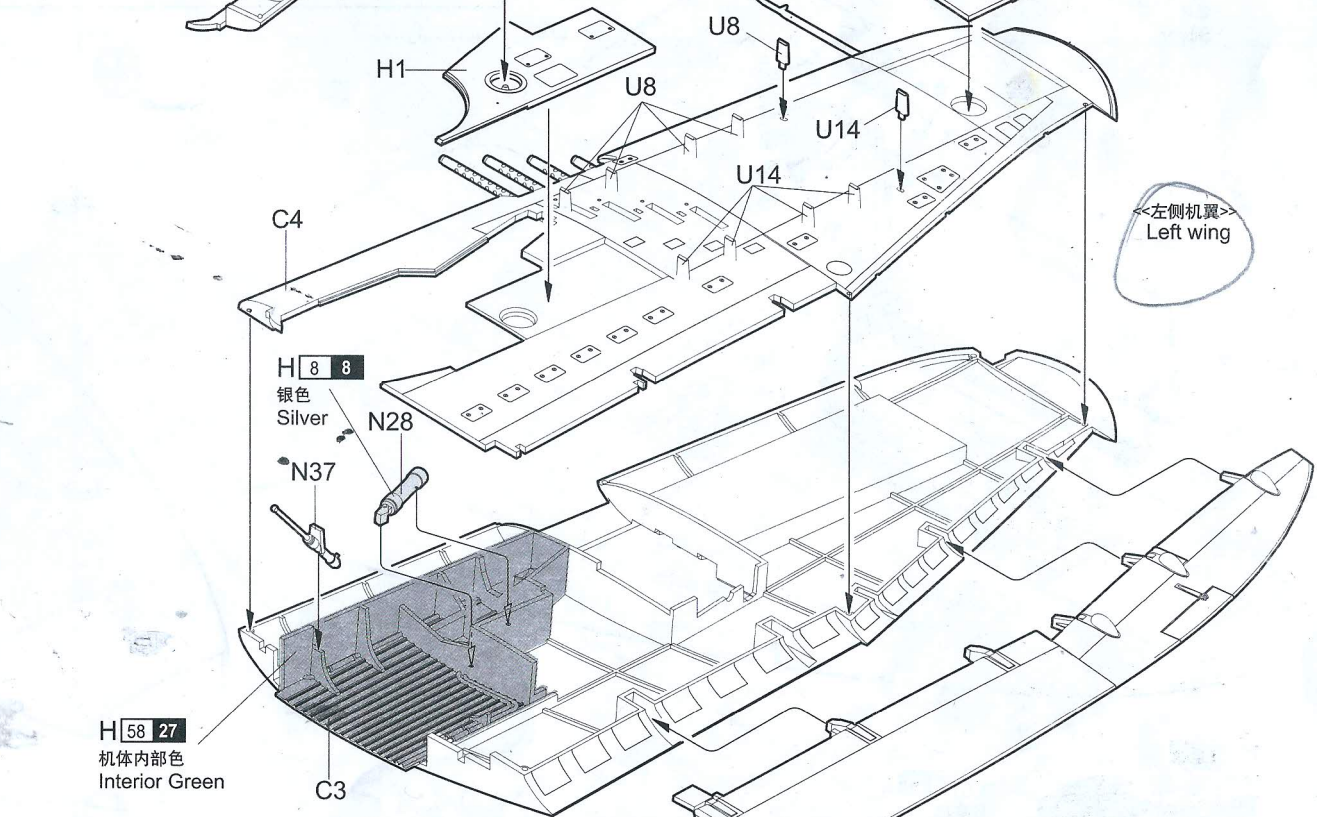
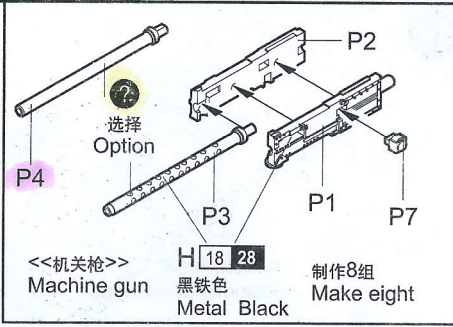
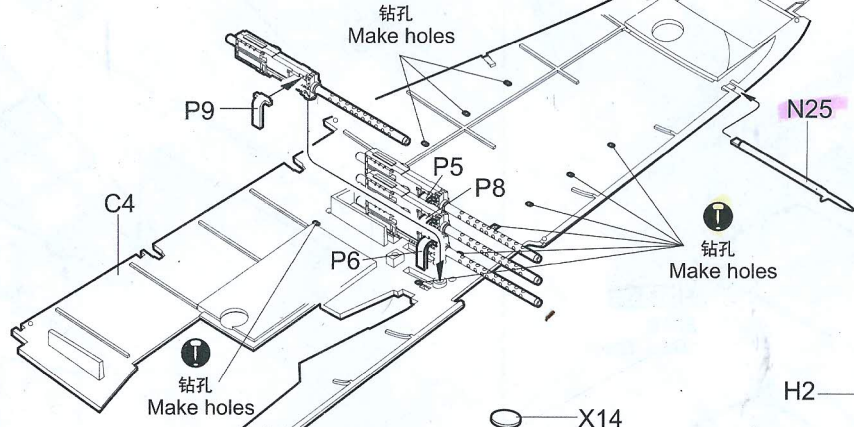

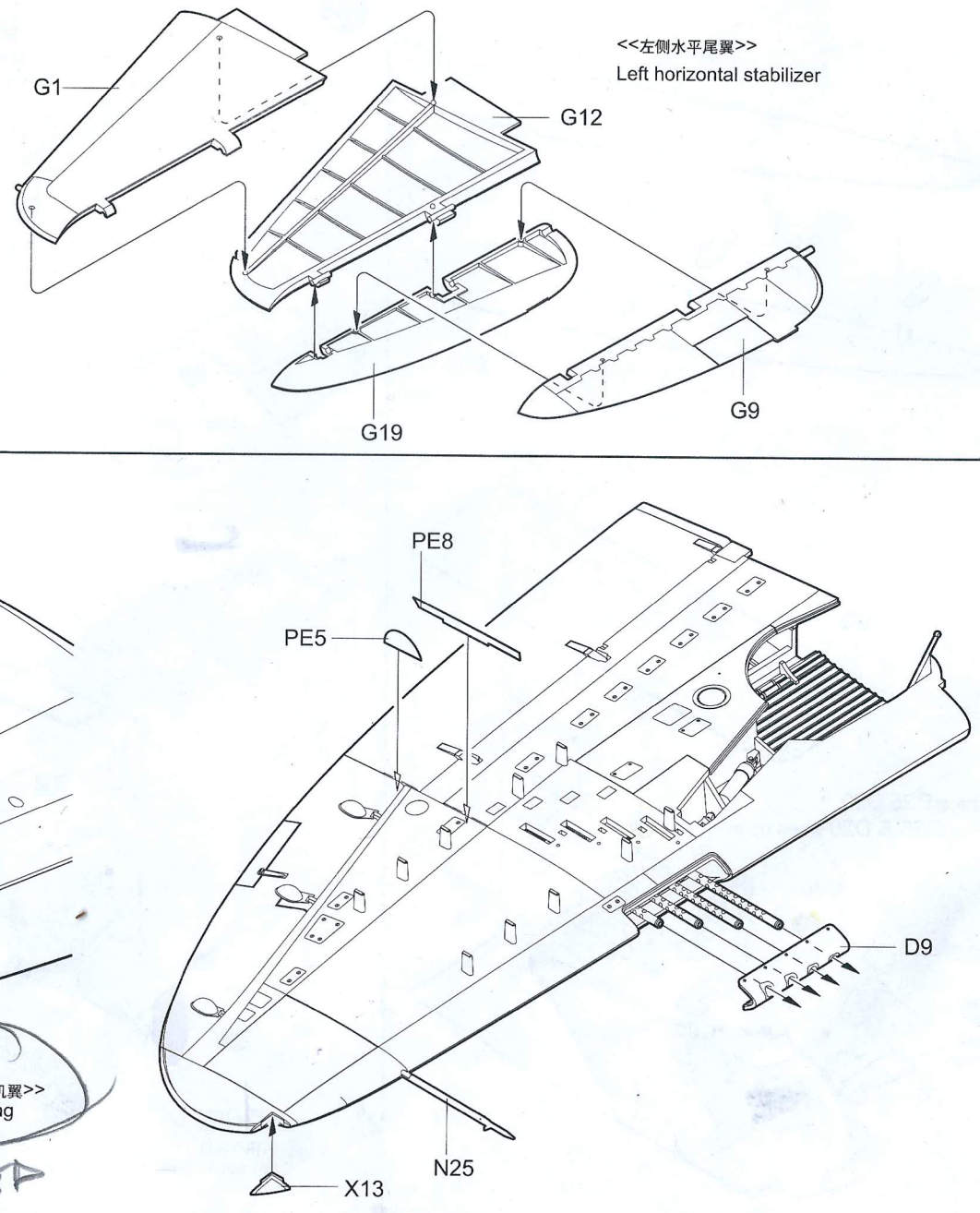
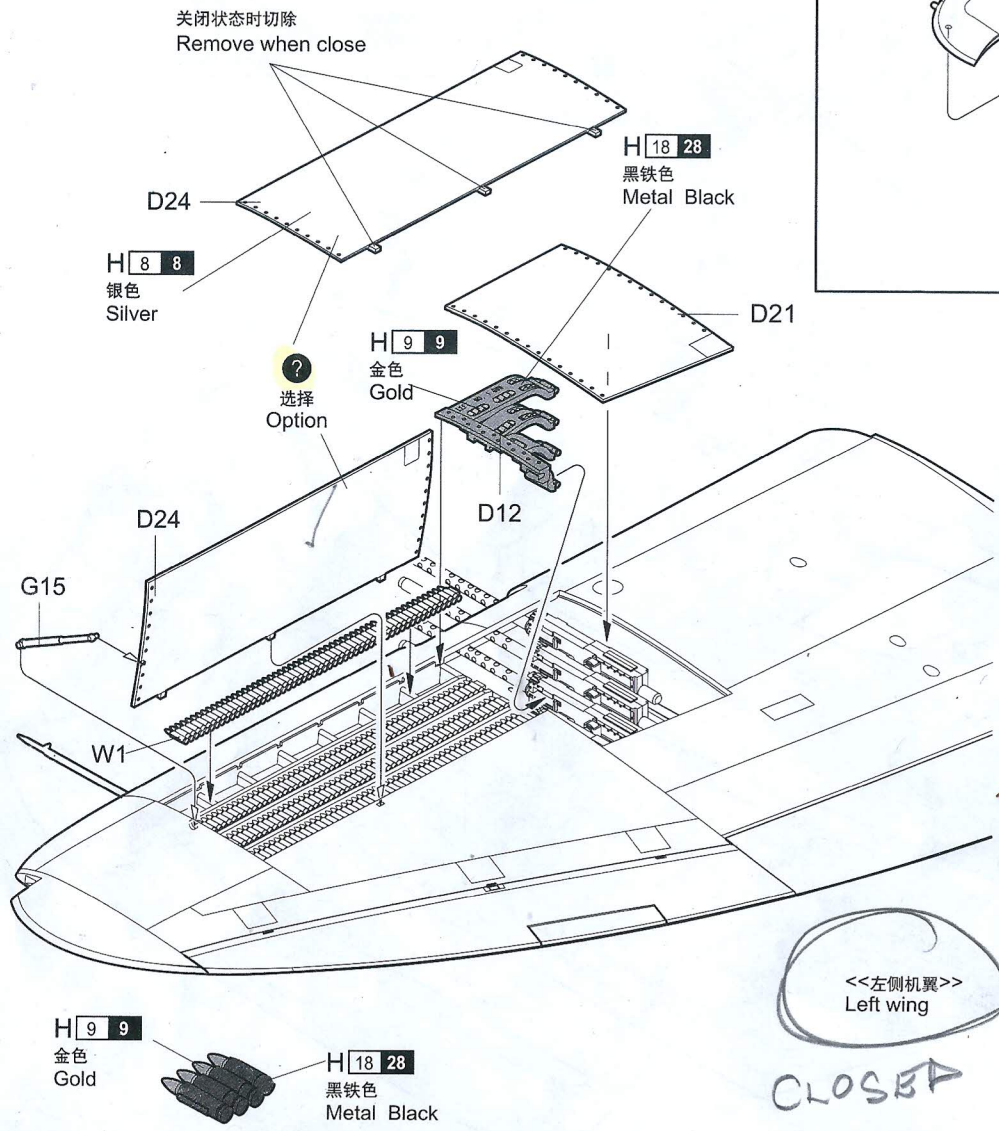

21

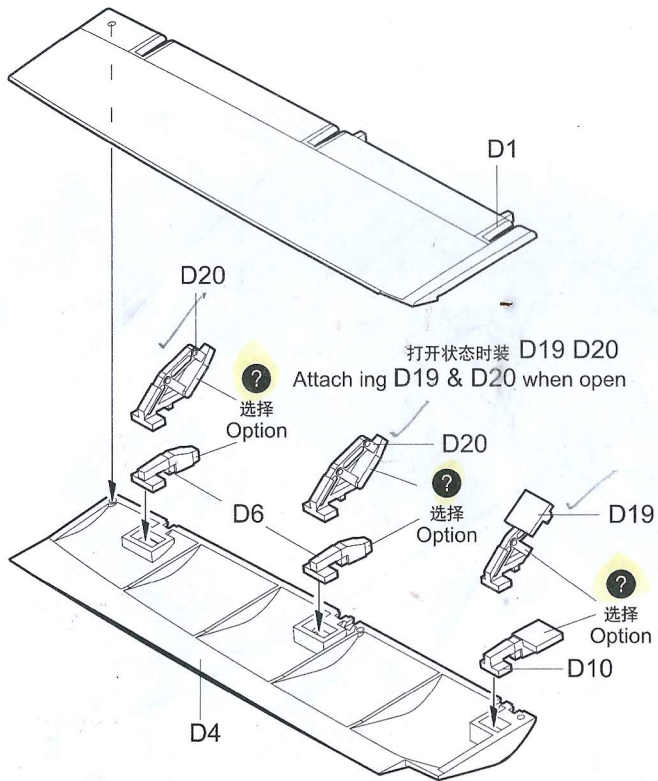
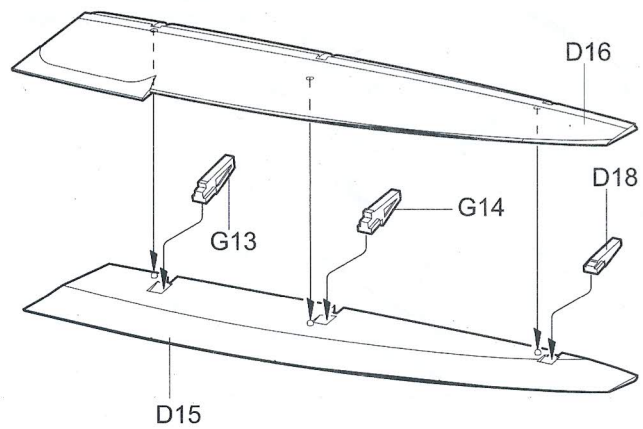

22

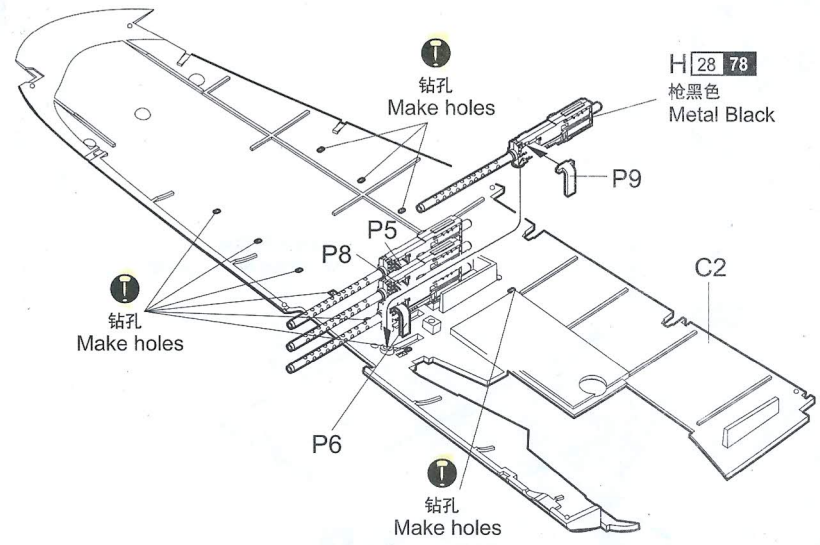

23

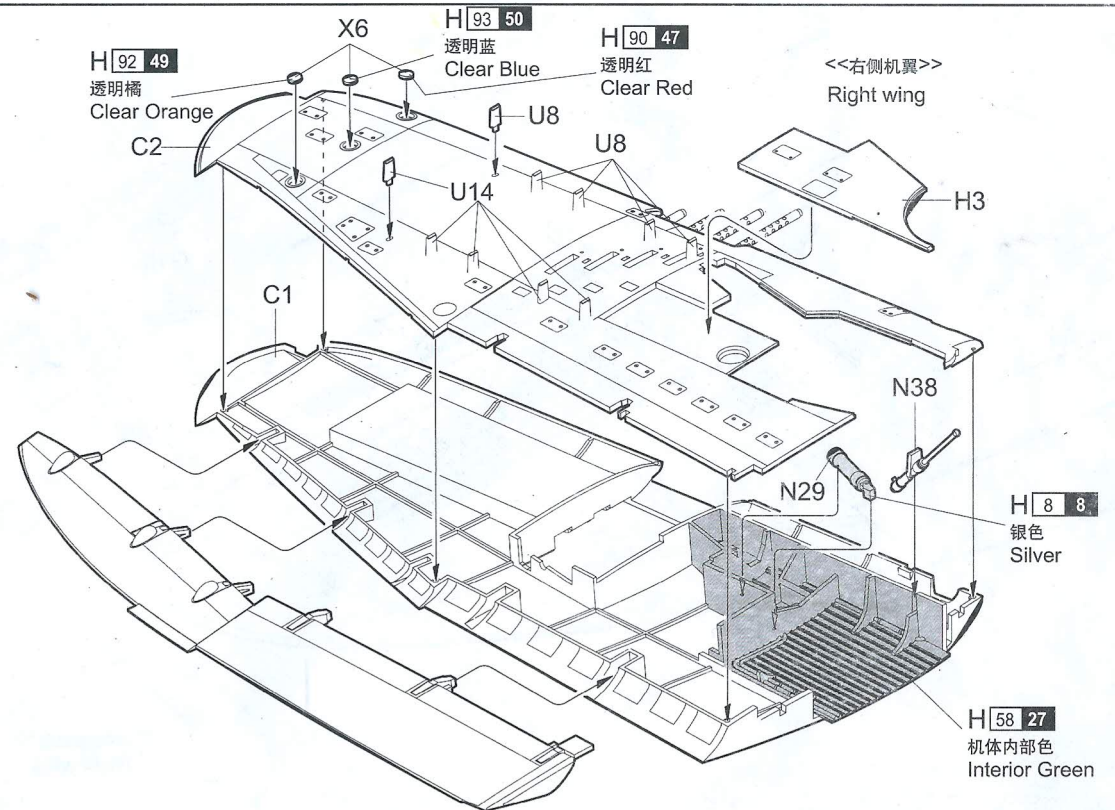

24

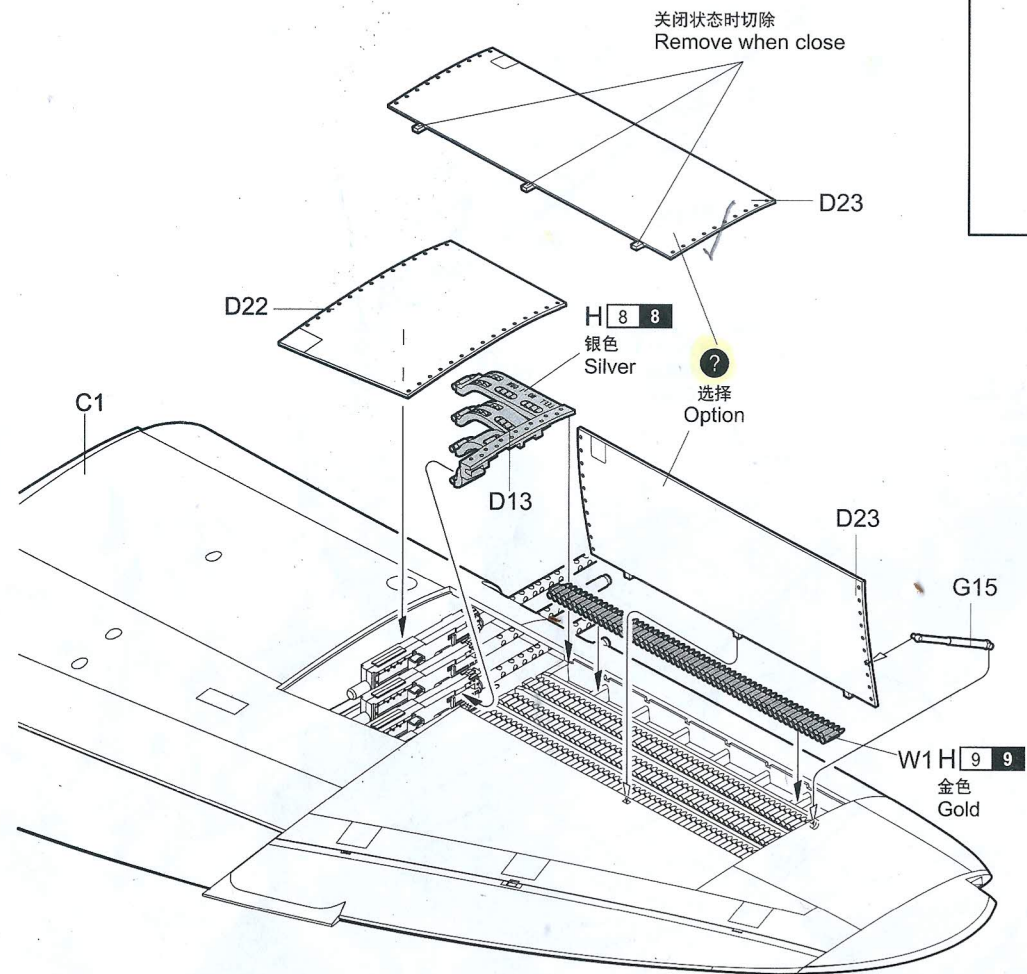

25

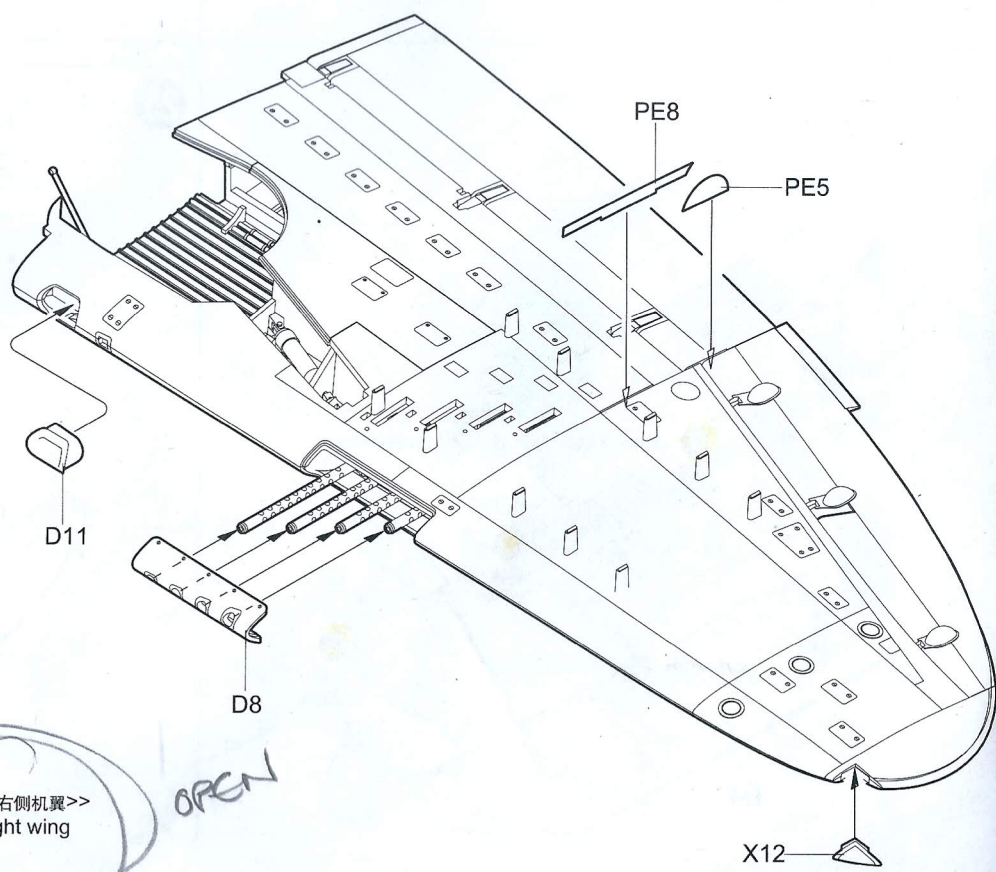
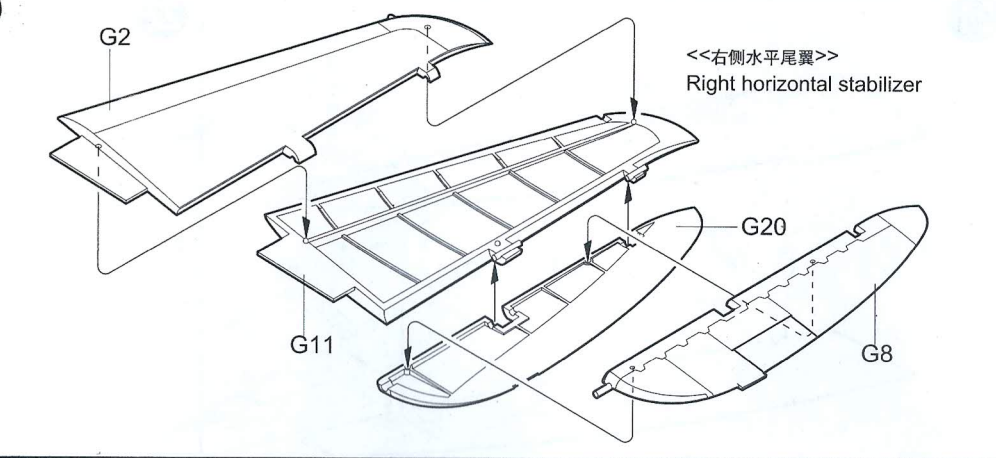

<<右侧机翼>>
Right wing

<<右侧机翼>>
Right wing

J1

J2

G10

X7

G18

H 90 47
透明红
Clear Red

H 8 8
银色
Silver

Q20

对侧G7
Opposite G7 G6

?
选择
Option

G3 对侧G4
Opposite G4

<<左侧机翼>>
Left wing

<<引擎罩>>
Cowling

M6

?
选择
Option

M8

M9

M7

H 58 27
机体内部色
Interior Green

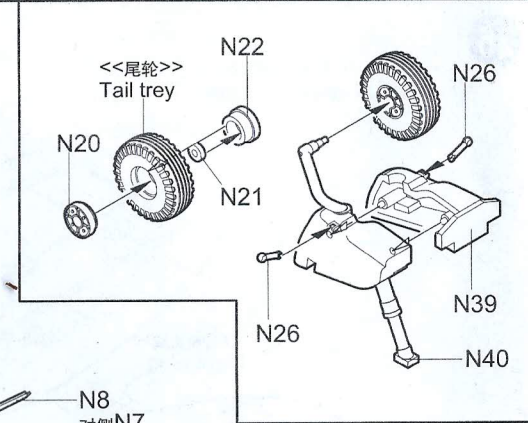
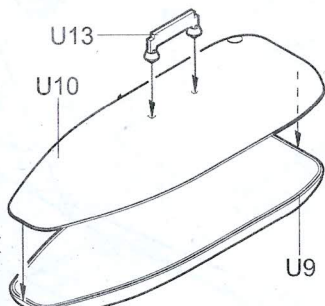
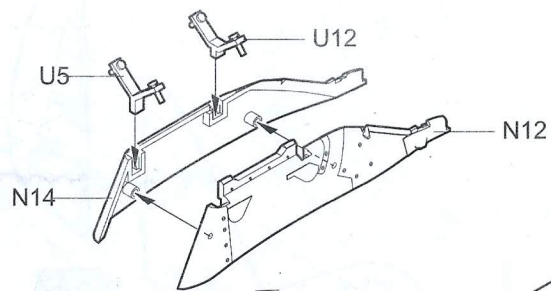

<<右侧起落架>>
Right undercarriage

对侧U20
Opposite U20

对侧N1
Opposite N1
N2

N8
对侧N7
Opposite N7

<<左侧起落架>>
Left undercarriage

U16
对侧相同
Both sides

<<引擎罩>>
Cowling

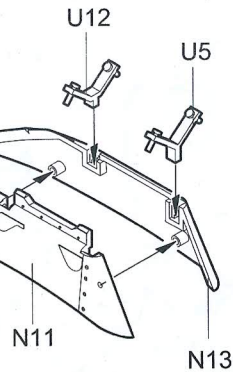

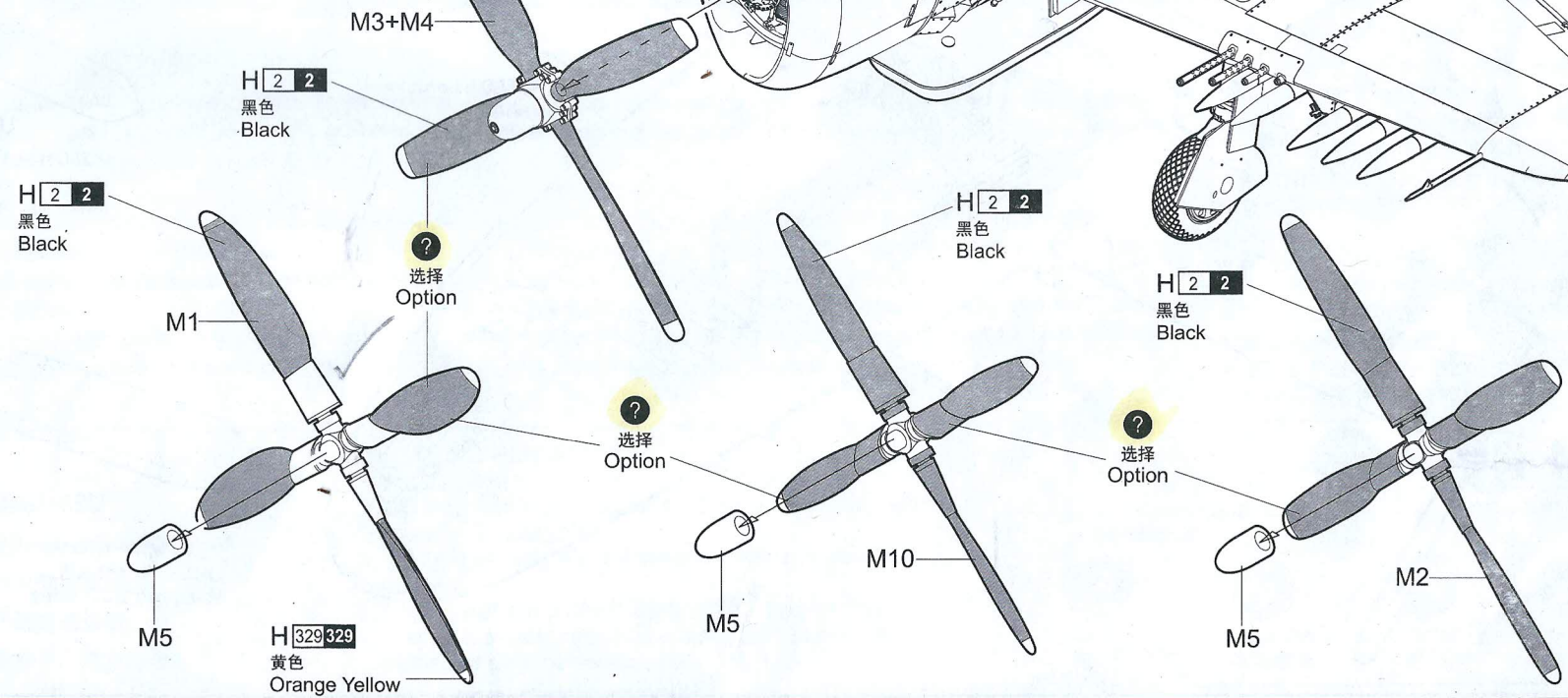
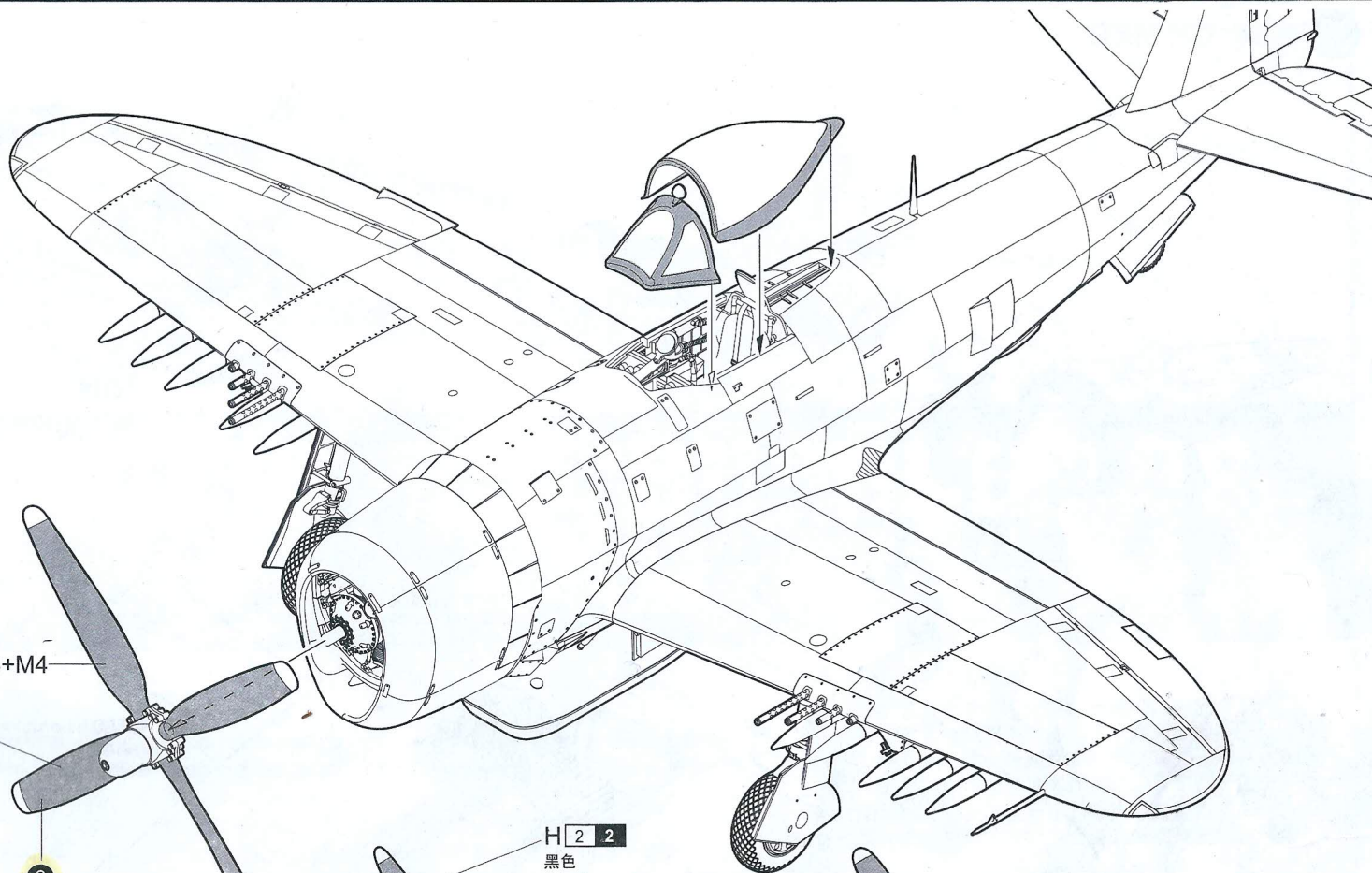
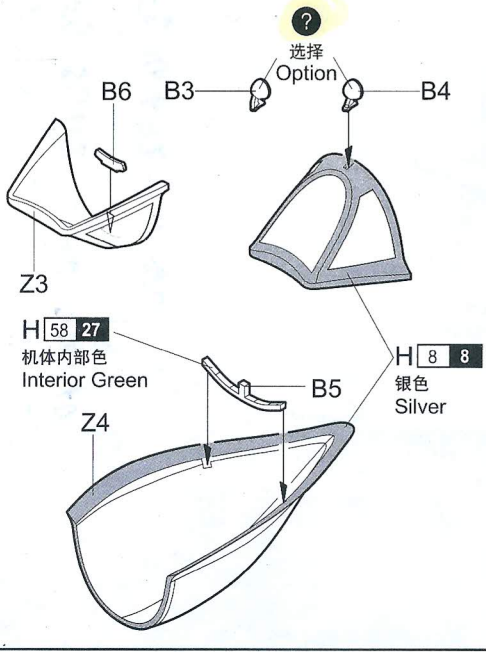

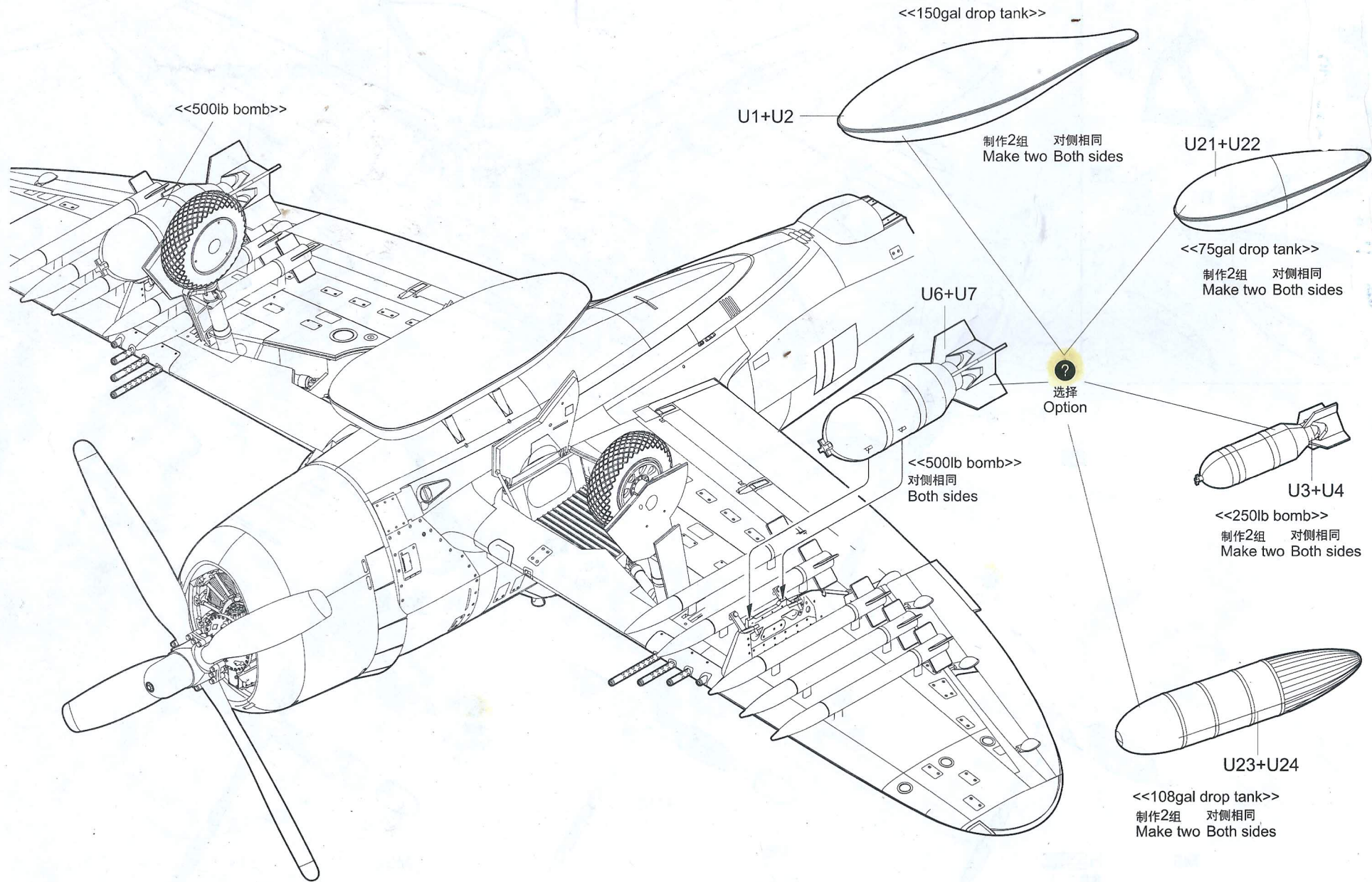

涂装同标贴指示 Painting & Marking guide

H 11 62	哑光白 Flat White	H 76 61	烧铁色 Burnt Iron	H 90 47	透明红 Clear Red
H 33 62	哑光黑 Flat Black	H 77 137	胎黑色 Tire Black	H 94	透明绿 Clear green
H 8 8	银色 Silver	H 71 21	土黄色 Middle Gray	H 304 304	橄榄色 Olive Drab
H 58 27	机体内部色 Interior Green				

A *Piot-Frederick Christensen.England,1944*

