

1:32 SCALE

Messerschmitt Bf 109E-3

德国BF109E-3战斗机

READ BEFORE ASSEMBLY:

Study and understand these instructions thoroughly before beginning assembly

When needed, remove photo-etch parts carefully using a modeling knife or photo etch sprue cutter, being careful not to damage or lose small parts.

Take extra care in handling photo etch parts in order to avoid injury

Apply instant cement sparingly to photo etch parts where instructed

- Tools recommended(not included in kit):Plastic and instant cements,sprue cutters,long nose pliers,modeling knife, small files, tweezers, pin vise & scissors. Soft cloth and sandpaper will also assist in construction
- Glue and paint are not included in the kit. Use plastic cement and hobby paints only. Color guide for purchasing paint is included in the kit.

装配之前仔细阅读

- 小心用模型锉刀锉平所有零件表面的注射浇口。
- 小心用刀片切下蚀刻片零件，不要遗失小零件。
- 用强力快干胶水粘合蚀刻片零件和金属轴。过量快干胶水使用可能导致可动零件会粘住，小心涂胶。
- 取蚀刻片时应特别注意安全，防止利边划伤手指。
- 某些零件表面需贴水上贴纸，请选择在装配的同时进行。
- 推荐模型工具(自备)：胶水，水口剪刀，长咀钳，刀片，锉刀，镊子，钳，钻，剪刀，瞬间快干胶。
- 软布同砂纸同时也应该是必备工具。
- 请使用塑料胶水和油漆，模型内不含。

水贴纸的使用:

1. 从水贴上剪下印花;

2. 将印花放入温水中浸10秒, 然后放在干净布上。

3. 拿着印花纸板将印花移到模型上;

4. 手指蘸水将印花移到适当的位置;

5. 用软布轻压印花直至水干, 汽泡消失。

DECAL APPLICATION:

1. Cut decals from sheet as needed
2. Dip the decal in warm water for about 10 seconds and then place on soft clean cloth.
3. Hold the decal backing sheet edge and gently slide the decal onto the model in its proper position.

4. While still wet, decal can be adjusted for better fit on model by dampening it gently with your finger.

5. When placed in the proper position, gently press decal down with a soft cloth until excess water and air bubbles are gone.

6. Allow decal to dry completely before handling model



cyanoacrylate glue
使用强力胶



weight
配重



make hole
钻孔



cut / remove
切除



option
选择



no cement
不涂胶水



decal
贴纸



bend
弯曲



file / sand
锉平

部品图 Parts

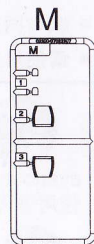
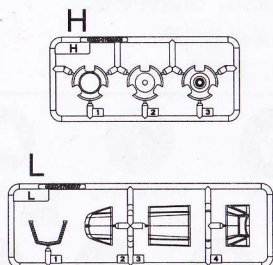
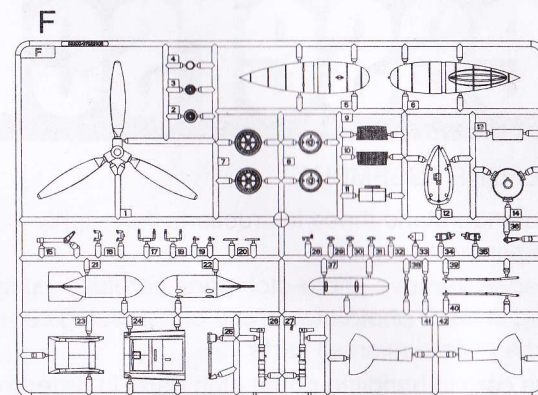
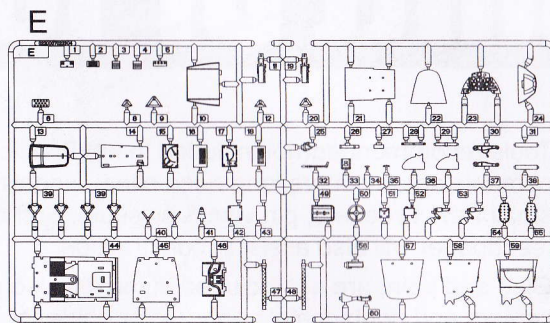
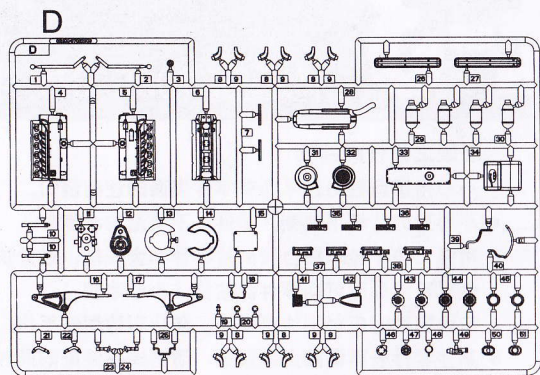
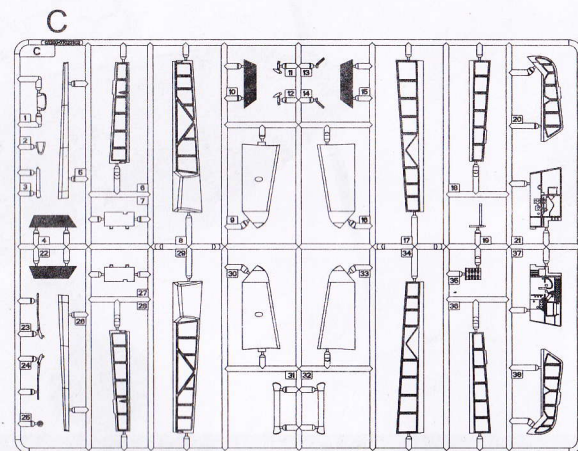
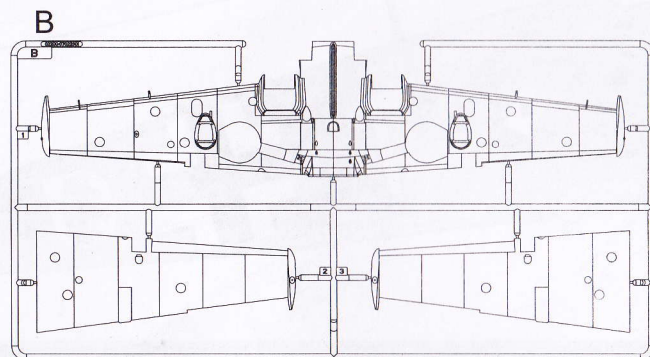
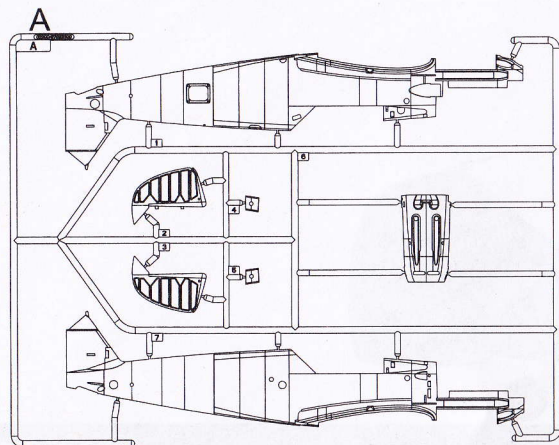

《主轮胎》
Main tyre



《尾轮胎》
Tail tyre



《蚀刻片》
PE

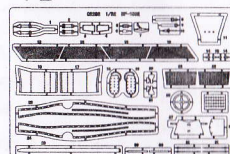

《水贴纸》
Decal

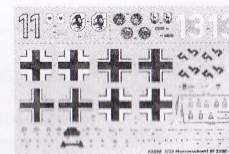

不用的部件: H1 PE11 PE20 PE21 PE27 PE28
Unused Parts

2

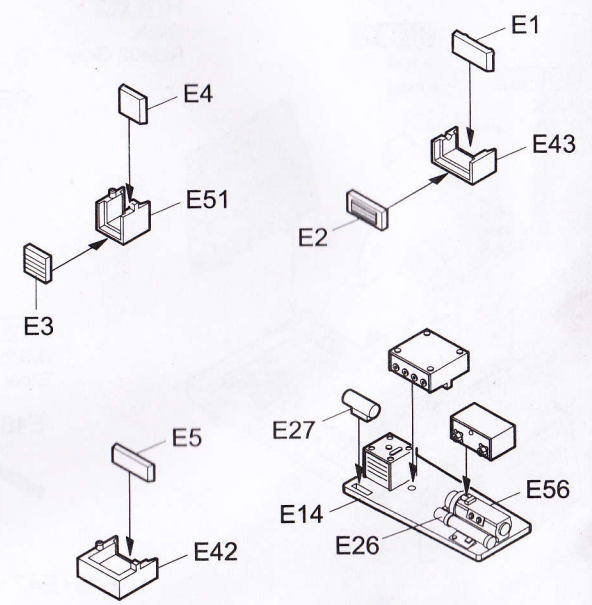
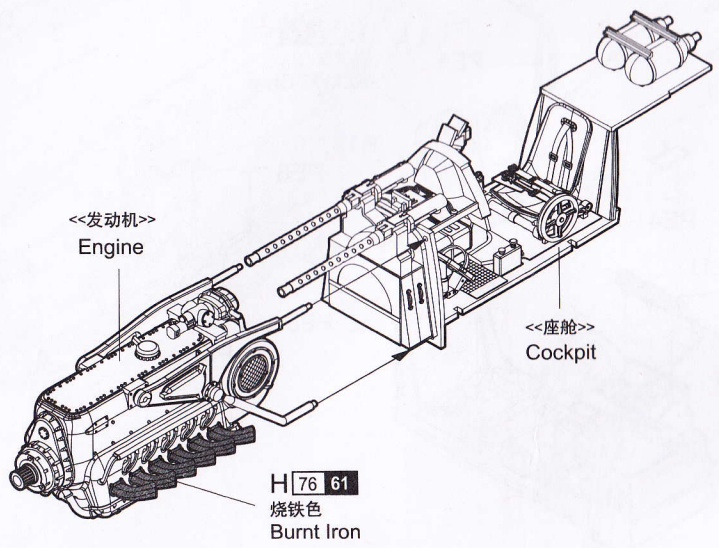
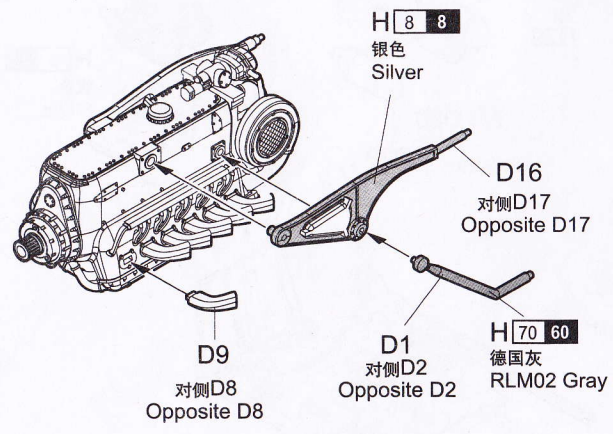
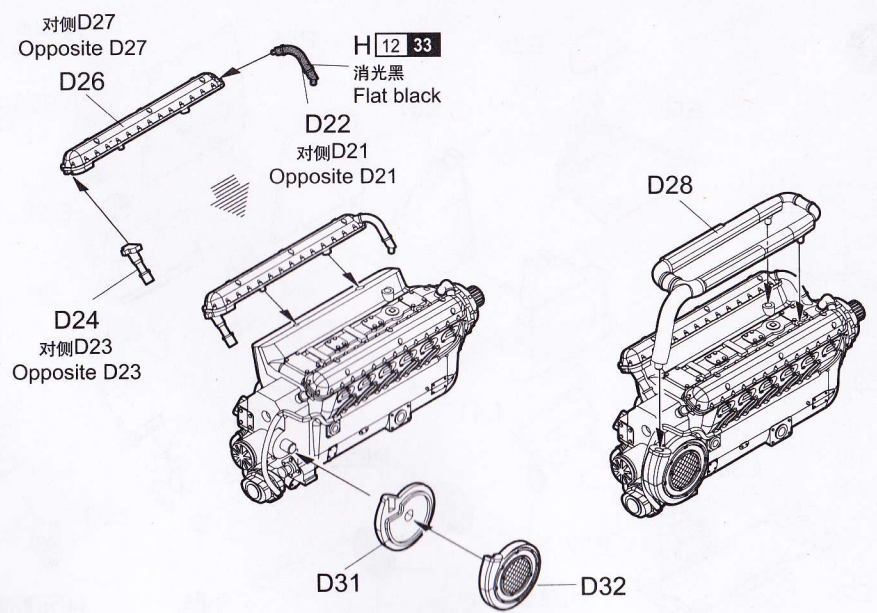
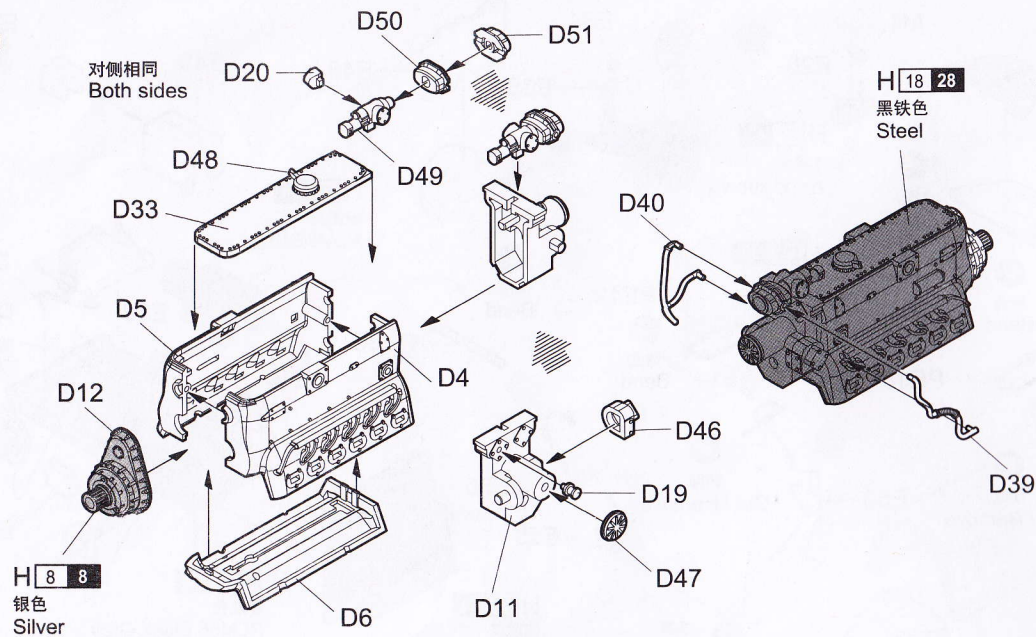

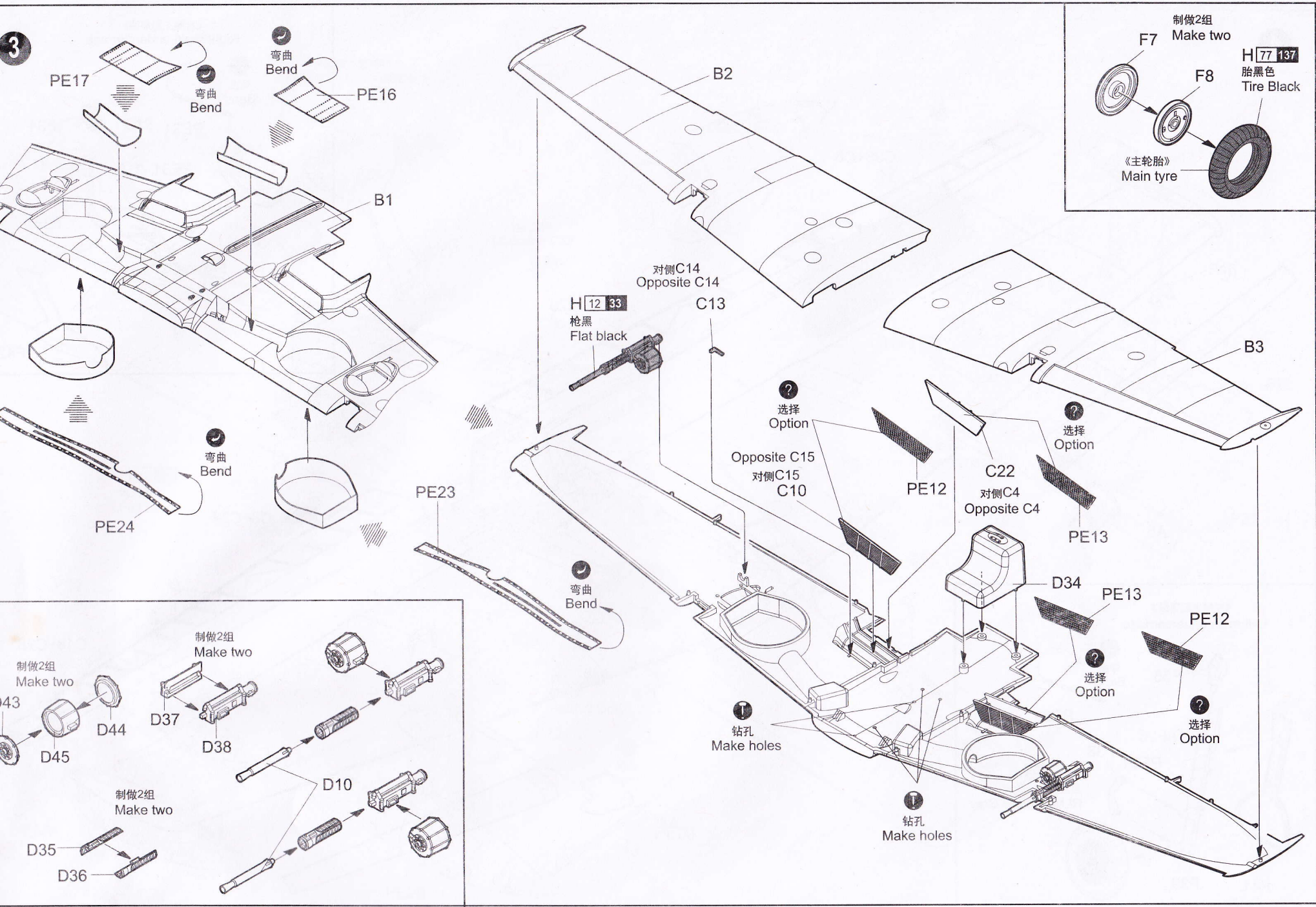

4

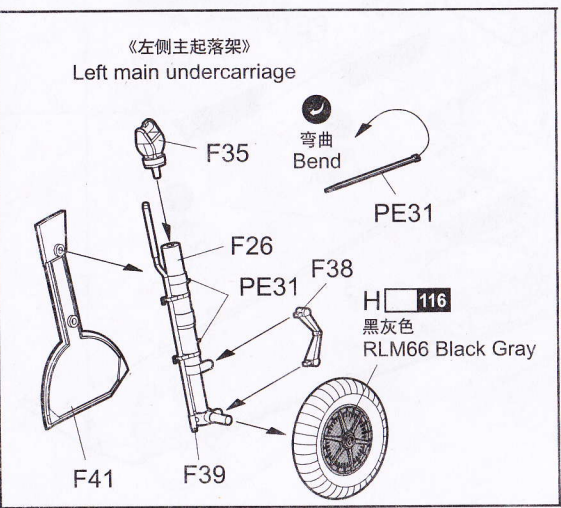
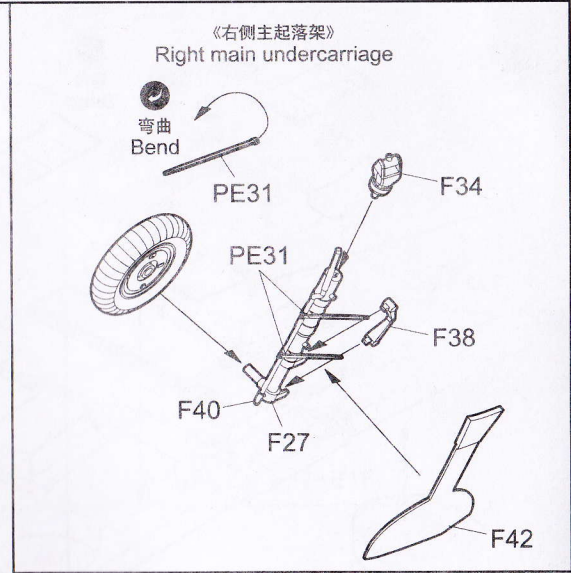
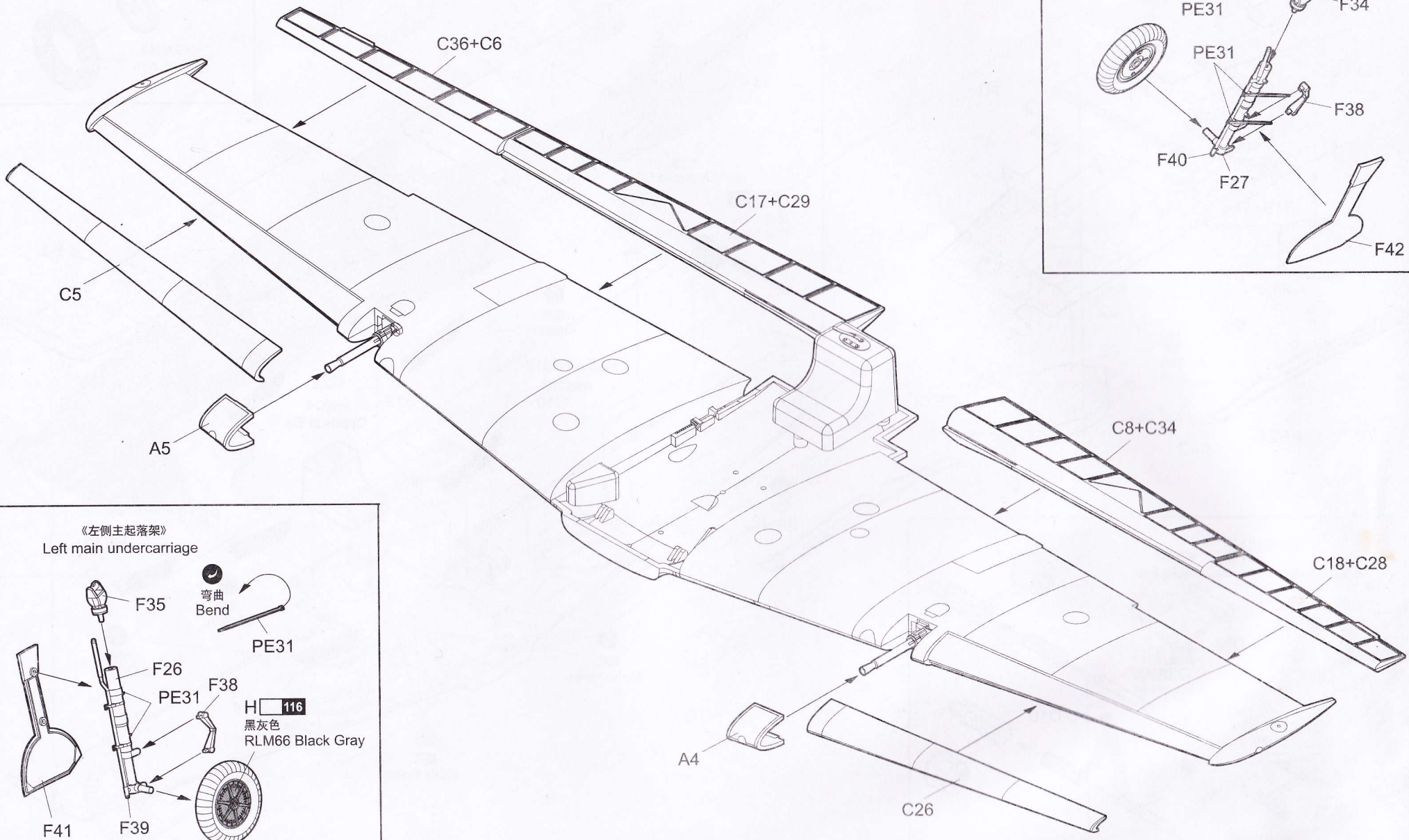

02288

6

<<左侧主起落架>>
Left main undercarriage

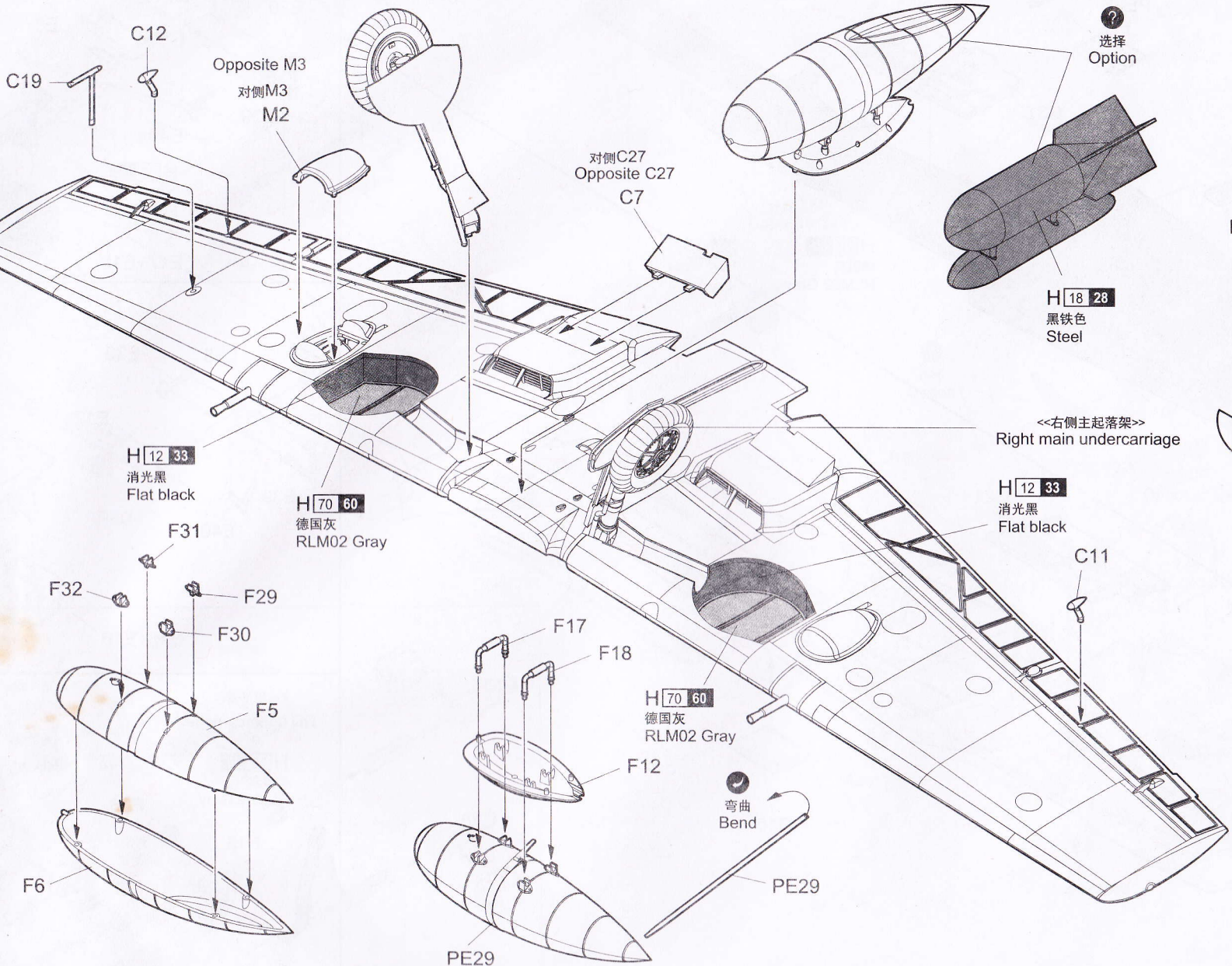

选择
Option

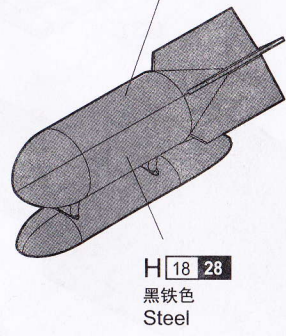

<<右侧主起落架>>
Right main undercarriage

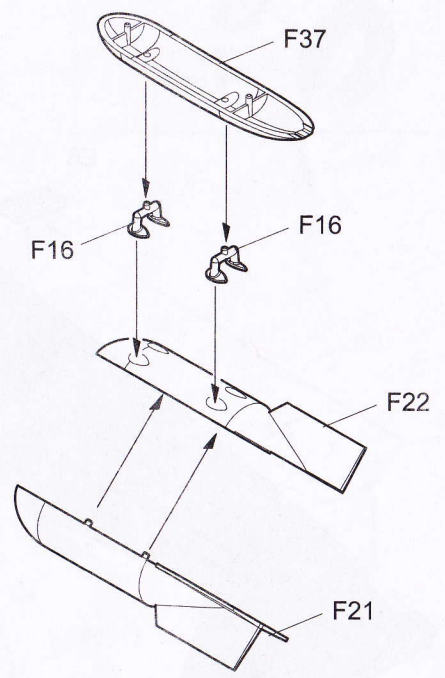

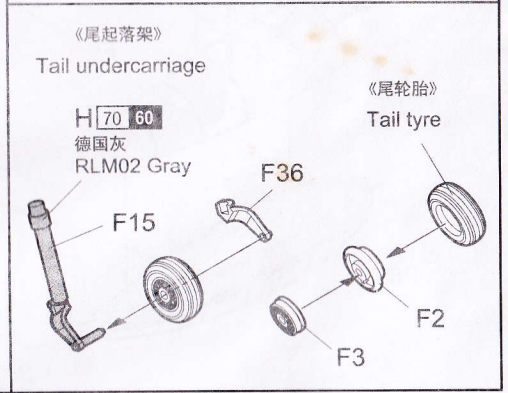
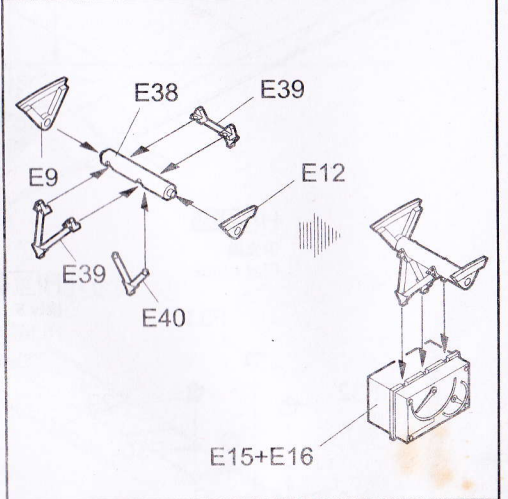
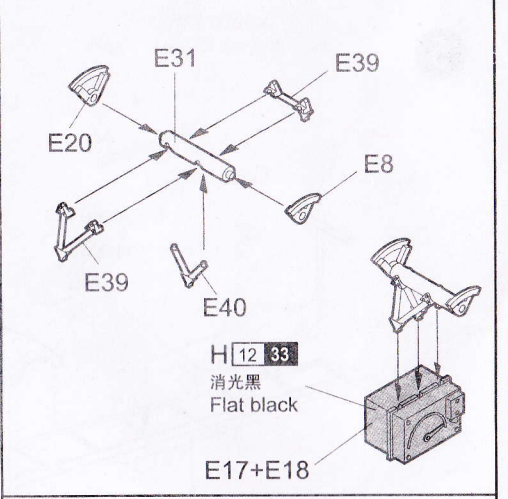
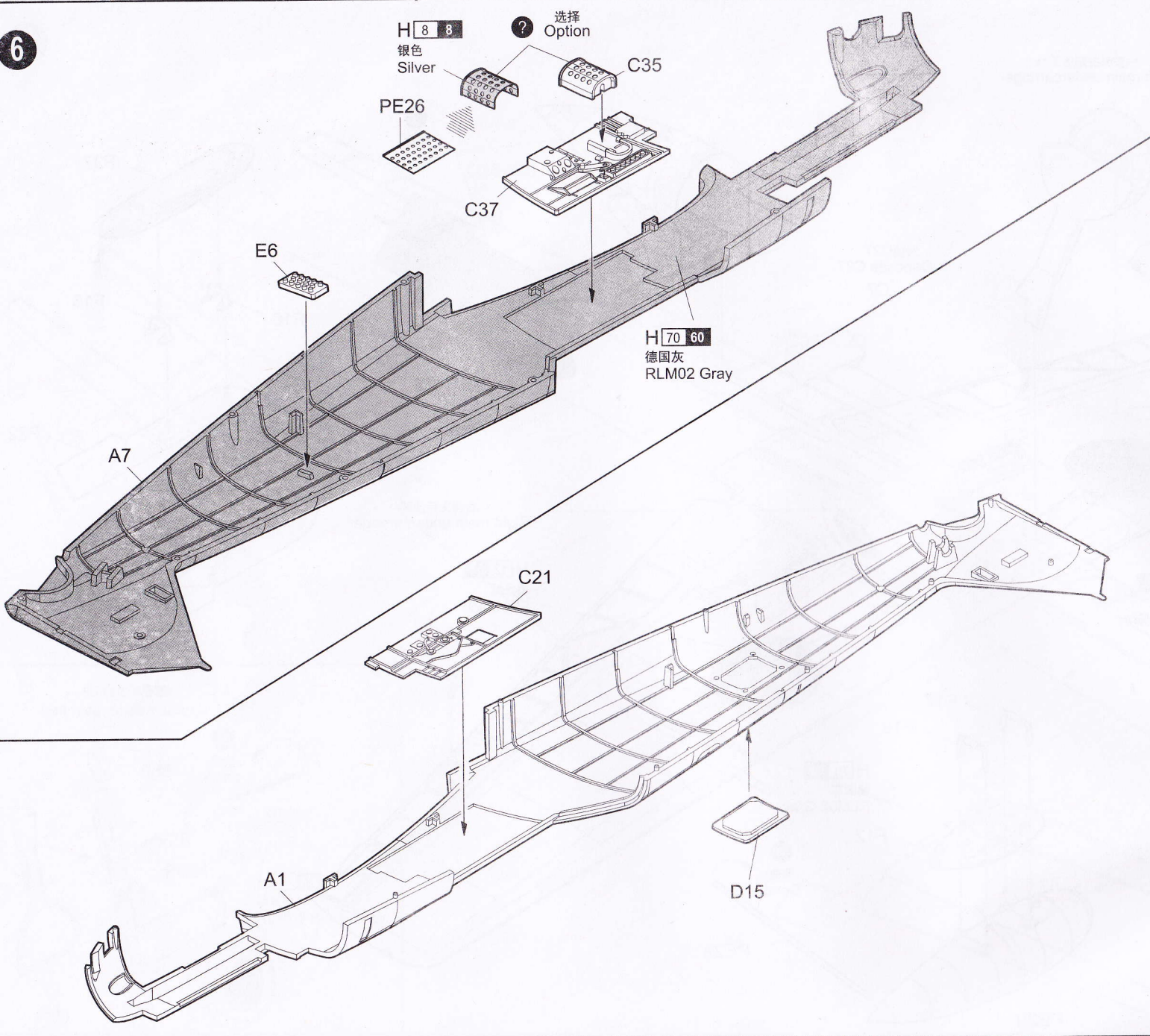

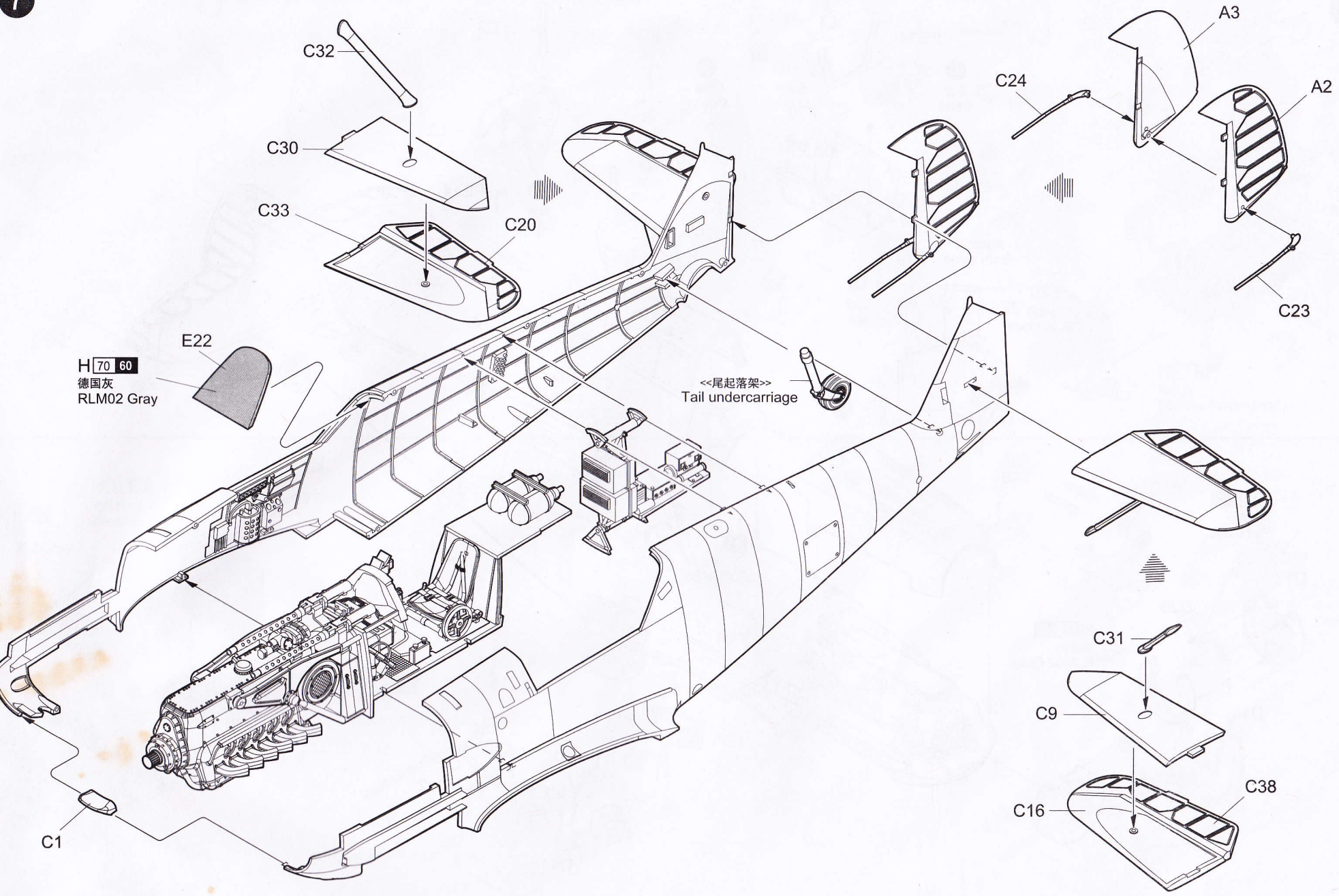

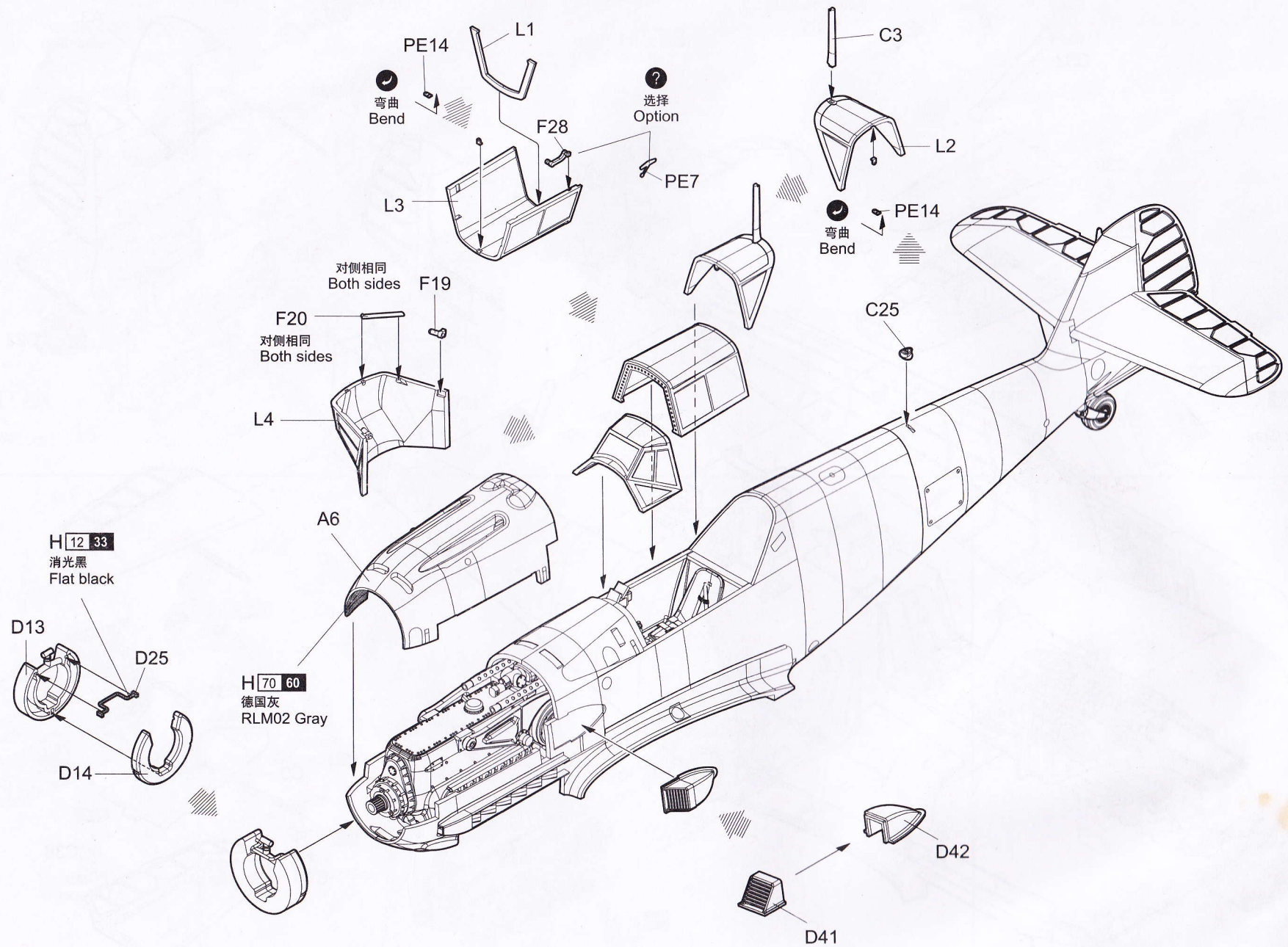

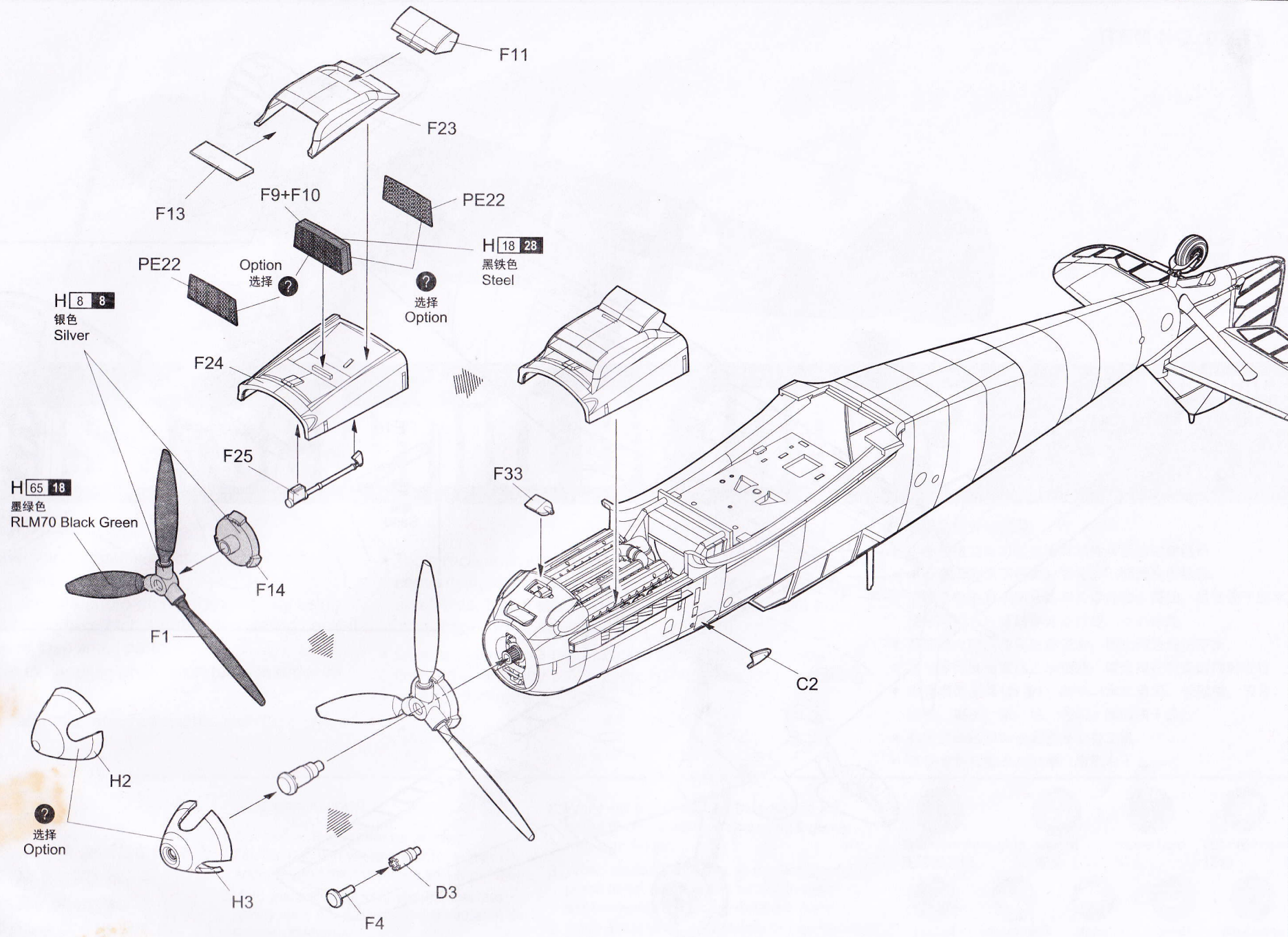

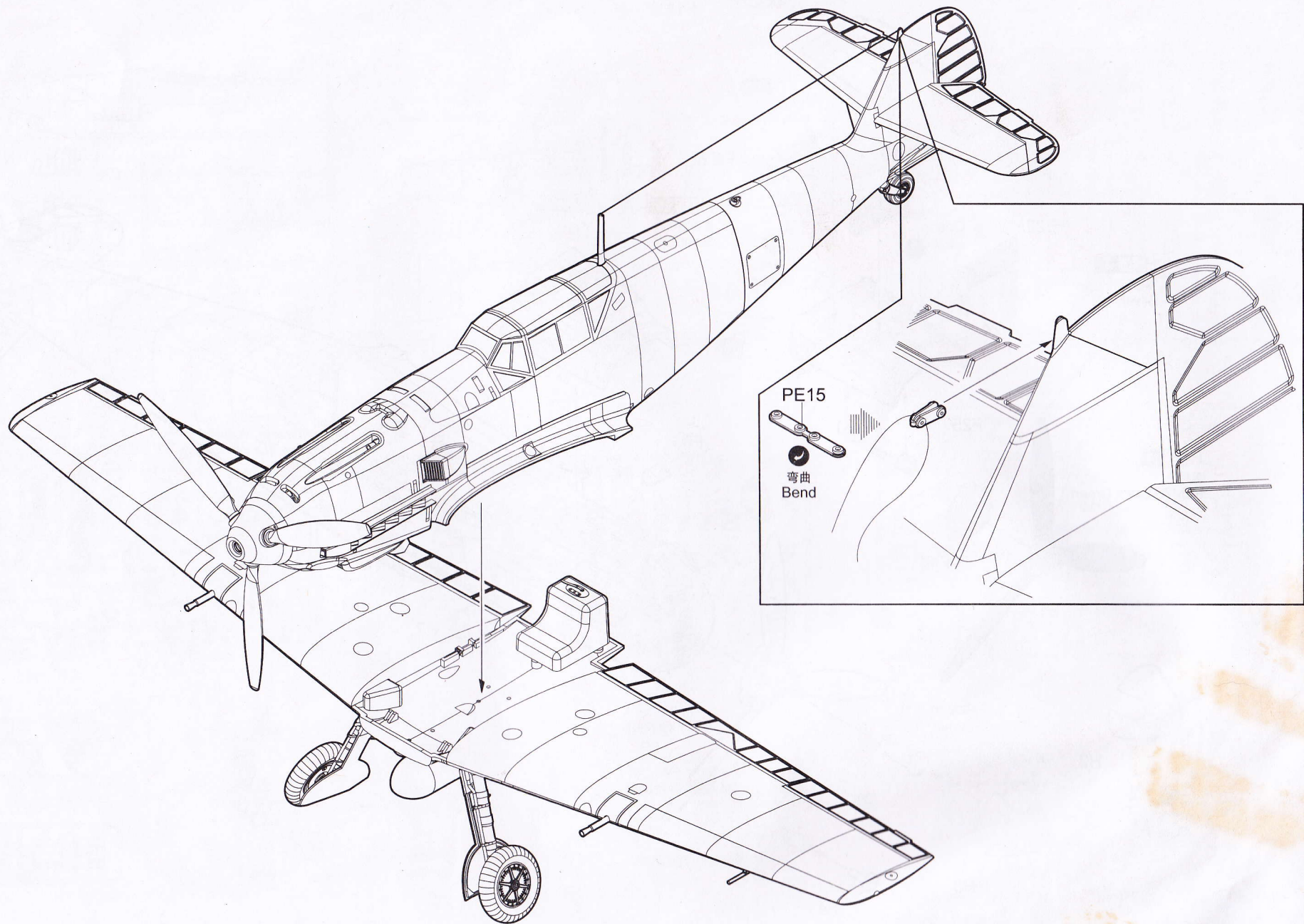

涂装同标贴指示 Painting & Marking guide

A Bf109E-3 Joseph Priller;6/JG51,Autumn 1940.

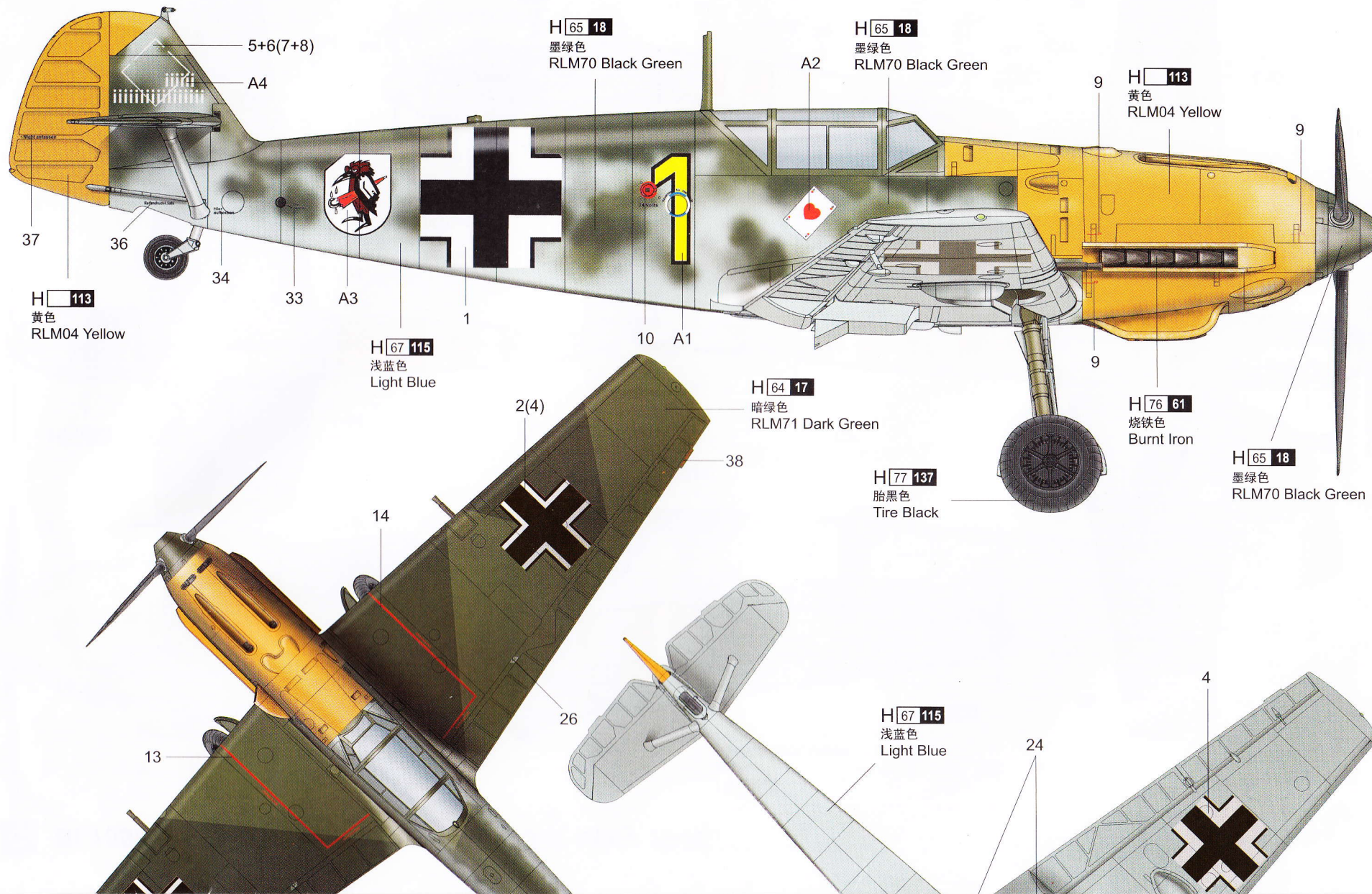

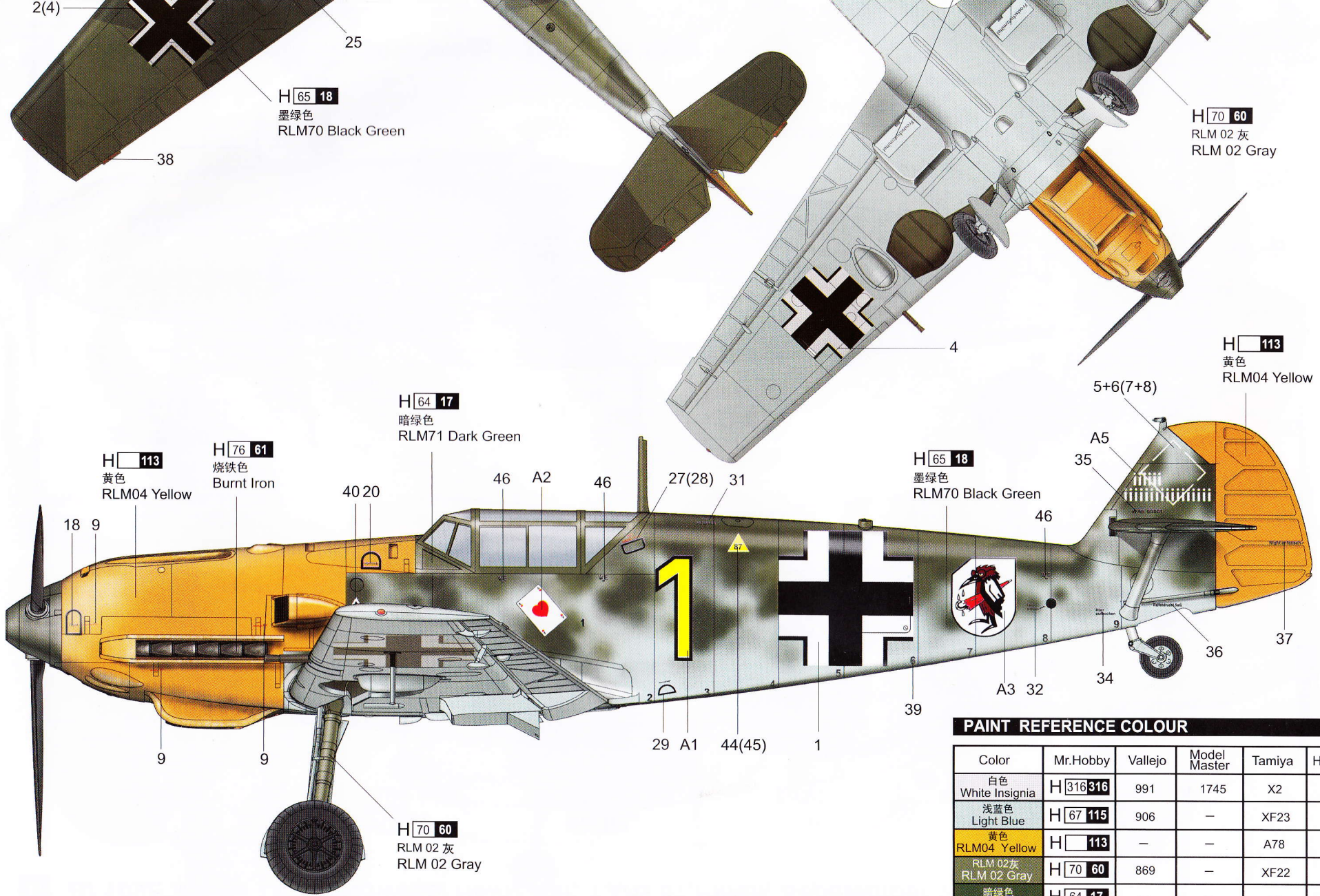

H AQUEOUS HOBBY COLOR X Mr. COLOR

PAINT REFERENCE COLOUR

Color	Mr.Hobby	Vallejo	Model Master	Tamiya	Humbrol
白色 White Insignia	H <input checked="" type="checkbox"/> 316 <input checked="" type="checkbox"/> 316	991	1745	X2	22
浅蓝色 Light Blue	H <input checked="" type="checkbox"/> 67 <input checked="" type="checkbox"/> 115	906	—	XF23	65
黄色 RLM04 Yellow	H <input checked="" type="checkbox"/> 113	—	—	A78	—
RLM 02灰 RLM 02 Gray	H <input checked="" type="checkbox"/> 70 <input checked="" type="checkbox"/> 60	869	—	XF22	—
暗绿色 RLM71 Dark Green	H <input checked="" type="checkbox"/> 64 <input checked="" type="checkbox"/> 17	—	—	—	—
墨绿色 RLM70 Black Green	H <input checked="" type="checkbox"/> 65 <input checked="" type="checkbox"/> 18	897	—	XF27	91
烧铁色 Burnt Iron	H <input checked="" type="checkbox"/> 76 <input checked="" type="checkbox"/> 61	863	1795	X10	53
胎黑色 Tire black	H <input checked="" type="checkbox"/> 77 <input checked="" type="checkbox"/> 137	—	—	—	—

02288 1/32 Messerschmitt Bf 109E-3

涂装同标贴指示 Painting & Marking guide

B Bf 109E' White 13' of feldwebel Heinz Bär, 1./JG 51, Pihen, Sepetember 1940.

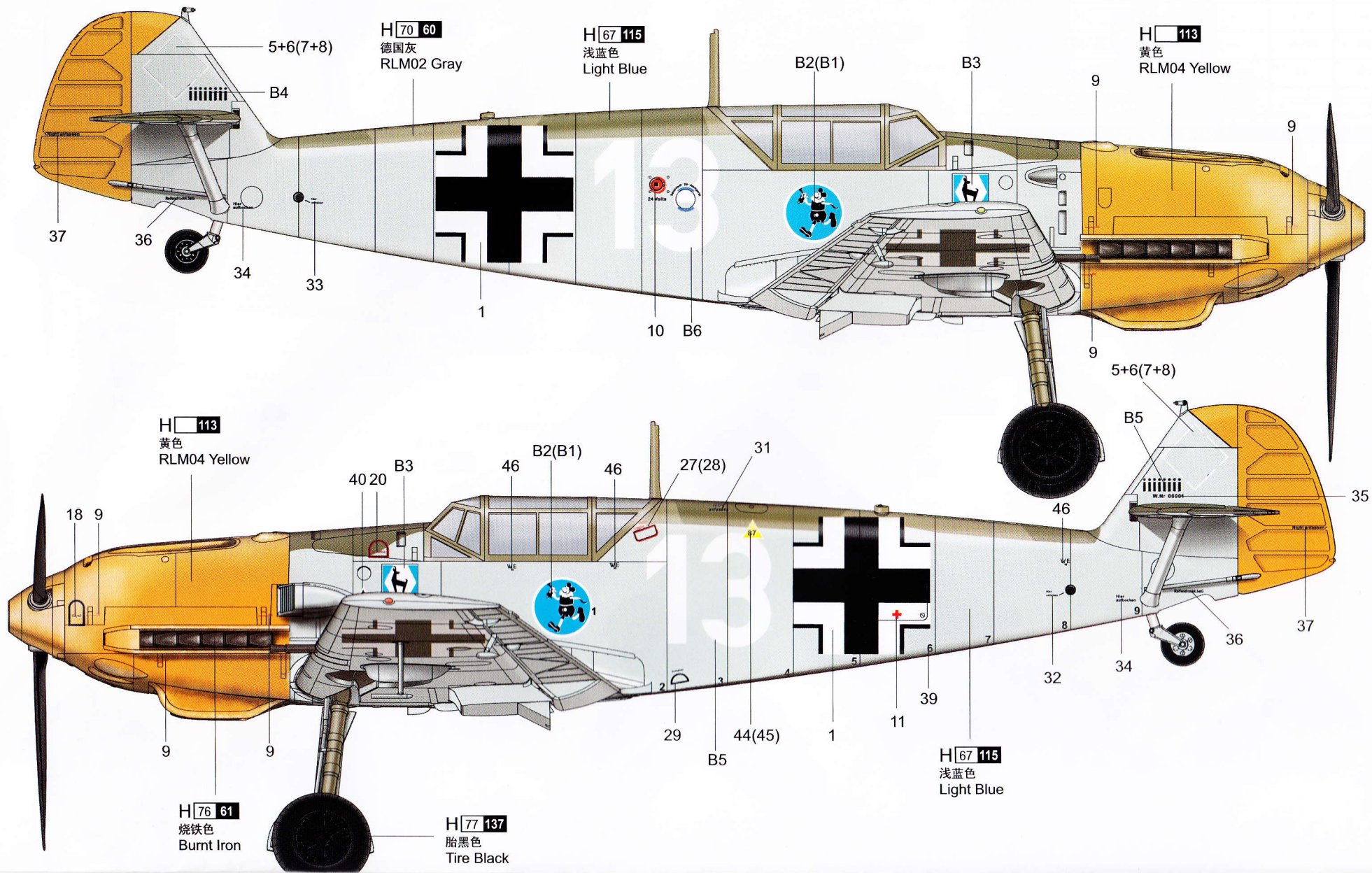

C Bf 109E-3, Swiss Fliegerkompanie J-371 early 1940.

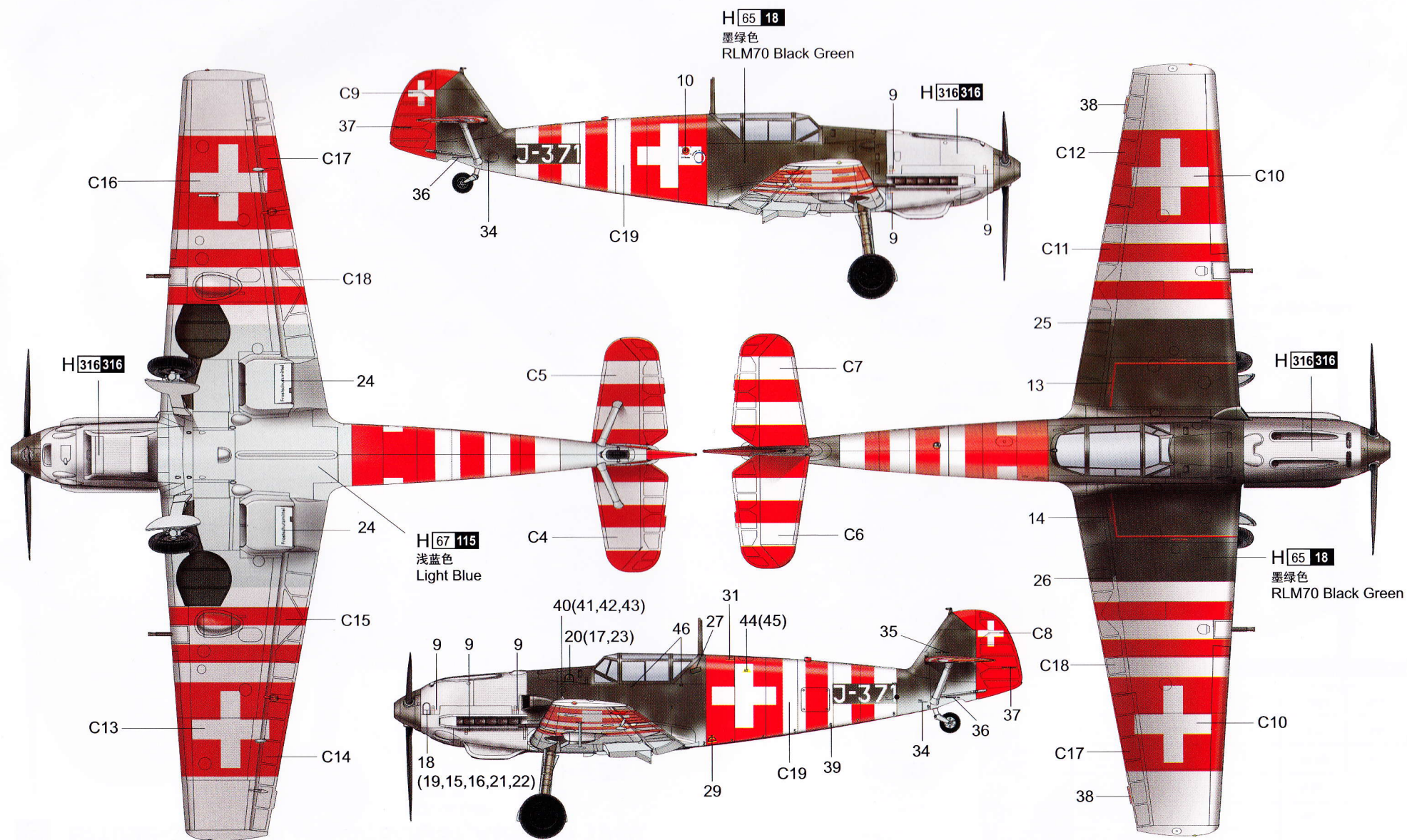

H X AQUEOUS HOBBY COLOR X Mr. COLOR

02288 1/32 Messerschmitt Bf 109E-3