

# PLA Type 63 107mm Rocket Launcher & BJ212 Military Jeep

中国63式火箭炮&北京212型军用吉普车

## READ BEFORE ASSEMBLY:

- Study and understand these instructions thoroughly before beginning assembly
- When needed, remove photo-etch parts carefully using a modeling knife or photo etch sprue cutter, being careful not to damage or lose small parts.
- Take extra care in handling photo etch parts in order to avoid injury
- Apply instant cement sparingly to photo etch parts where instructed
- Tools recommended(not included in kit):Plastic and instant cements, sprue cutters,long nose pliers,modeling knife, small files, tweezers, pin vise & scissors. Soft cloth and sandpaper will also assist in construction
- Glue and paint are not included in the kit. Use plastic cement and hobby paints only. Color guide for purchasing paint is included in the kit.

## 装配之前仔细阅读

- 小心用模型锉刀锉平所有零件表面的注射浇口。
- 小心用刀片切下蚀刻片零件，不要遗失小零件。
- 用强力快干胶水粘合蚀刻片零件和金属轴。过量快干胶水使用可能导致可动零件会粘住，小心涂胶。
- 取蚀刻片时应特别注意安全，防止利边划伤手指。
- 某些零件表面需贴上水贴纸，请选择在装配的同时进行。
- 推荐模型工具(自备)：胶水，水口剪刀，长咀钳，刀片，锉刀，镊子，钳，钻，剪刀，瞬间快干胶。
- 软布同砂纸同时也应该是必备工具。
- 请使用塑料胶水和油漆，模型内不含。



配重  
Weight



使用强力胶  
Cyanoacrylate glue



钻孔  
Make hole



切除  
Cut / Remove



贴纸  
Decal



锉平  
File / Sand



选择  
Option



不涂胶水  
No cement



弯曲  
Bend

## 水贴纸的使用:

- 1.从水贴纸上剪下印花;
- 2.将印花放入温水中浸10秒，然后放在干净布上。
- 3.拿着印花纸板将印花移到模型上;
- 4.手指蘸水将印花移到适当的位置;
- 5.用软布轻压印花直至水干，气泡消失

## DECAL APPLICATION

- 1.Cut decals from sheet as needed
- 2.Dip the decal in warm water for about 10 seconds and then place on soft clean cloth.
- 3.Hold the decal backing sheet edge and gently slide the decal onto the model in its proper position.

- 4.While still wet,decal can be adjusted for better fit on model by dampening it gently with your finger.
- 5.When placed in the proper position,gently press decal down with a soft cloth until excess water and air bubbles are gone.
- 6.Allow decal to dry completely before handling model

# 部品图 Parts

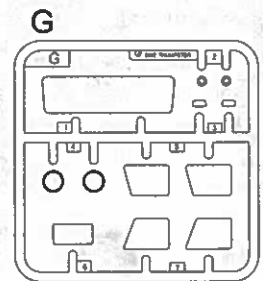
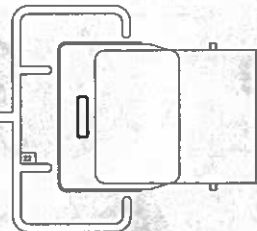
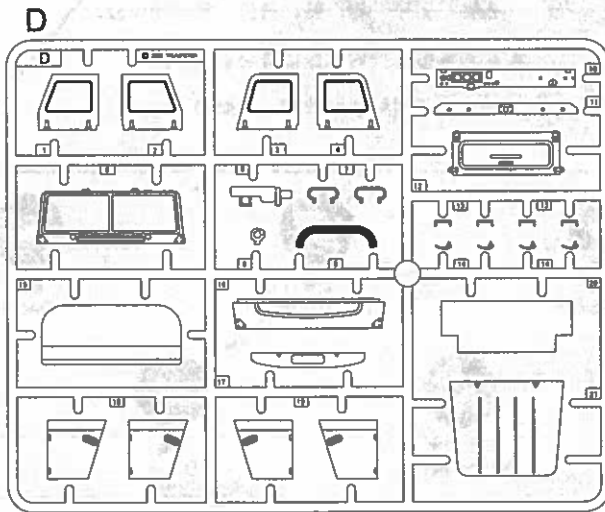
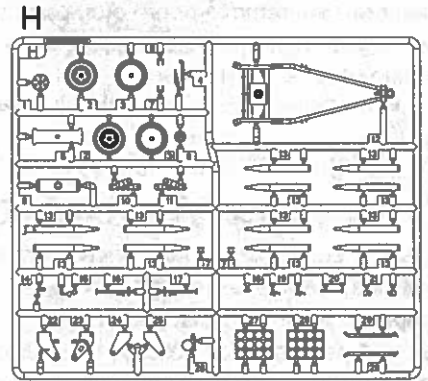
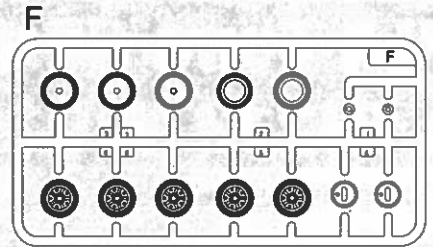
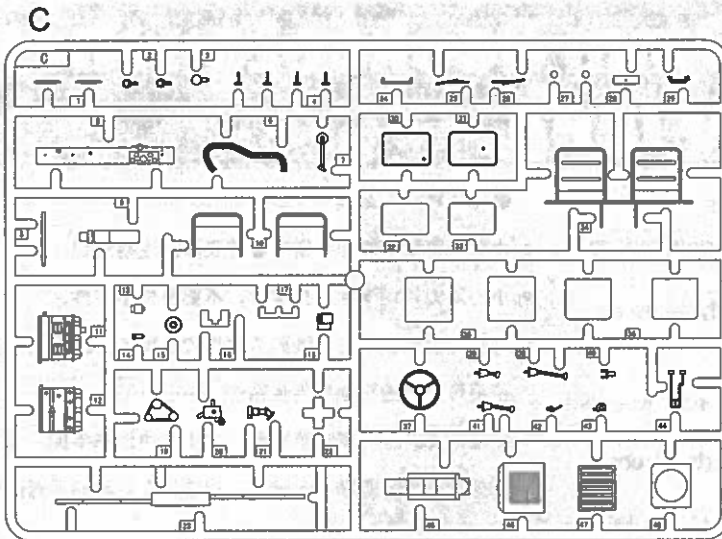
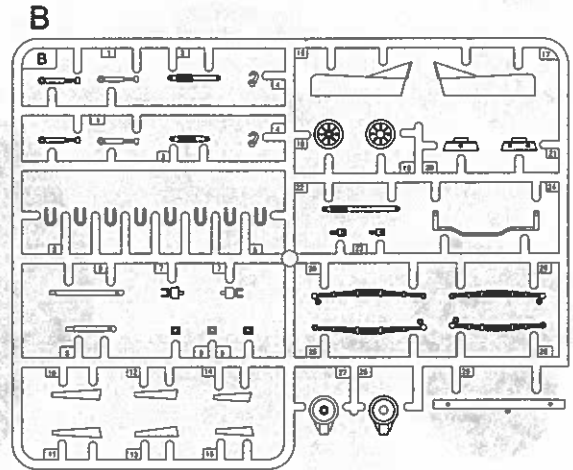
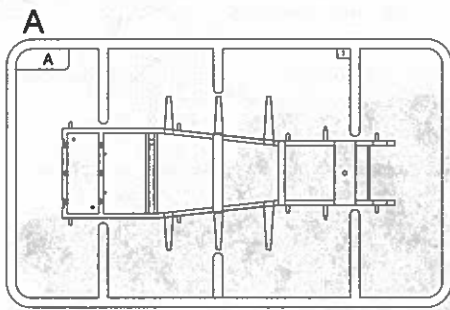

《金属轴》  
Metal shaft



∅3.4 《钢管》  
Metal duct X12



《轮胎I》  
Tyre X4



《轮胎II》  
Tyre X2



《蚀刻片》  
PE



《水贴》  
Decal

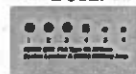

《车体》  
body

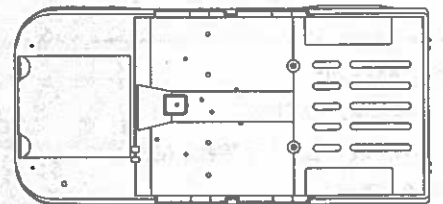

不用部品: C2, C5, C6, C9, C28, C29, C43  
Unused parts



5

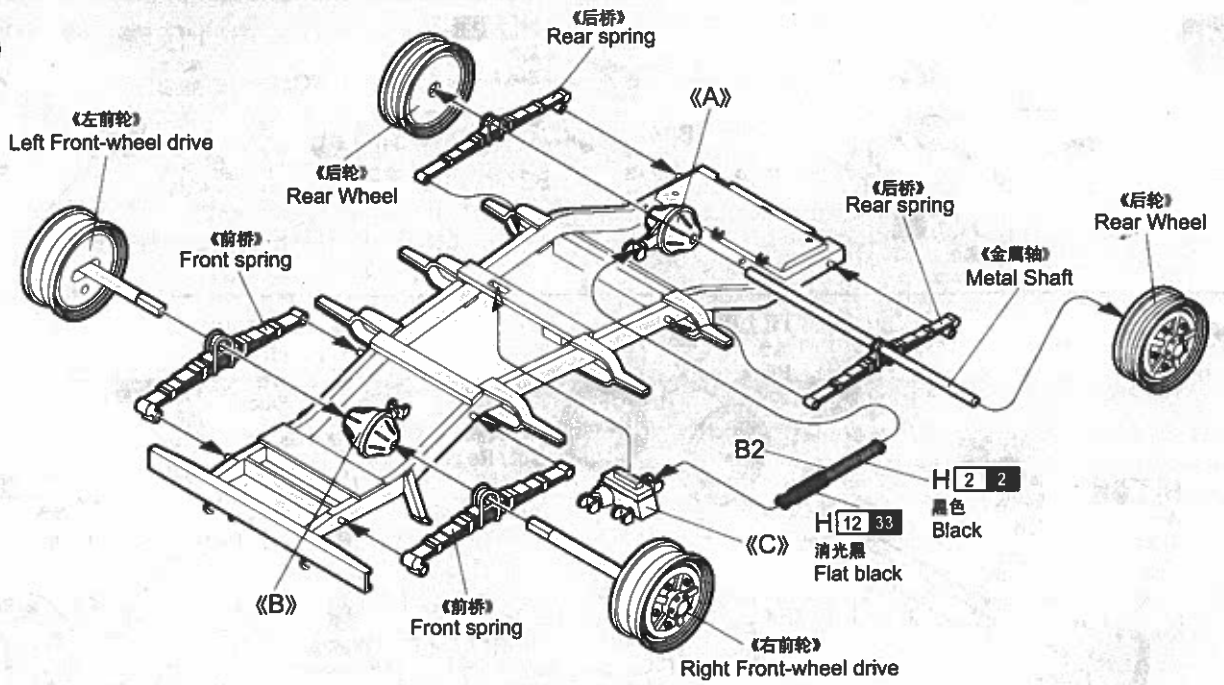

6

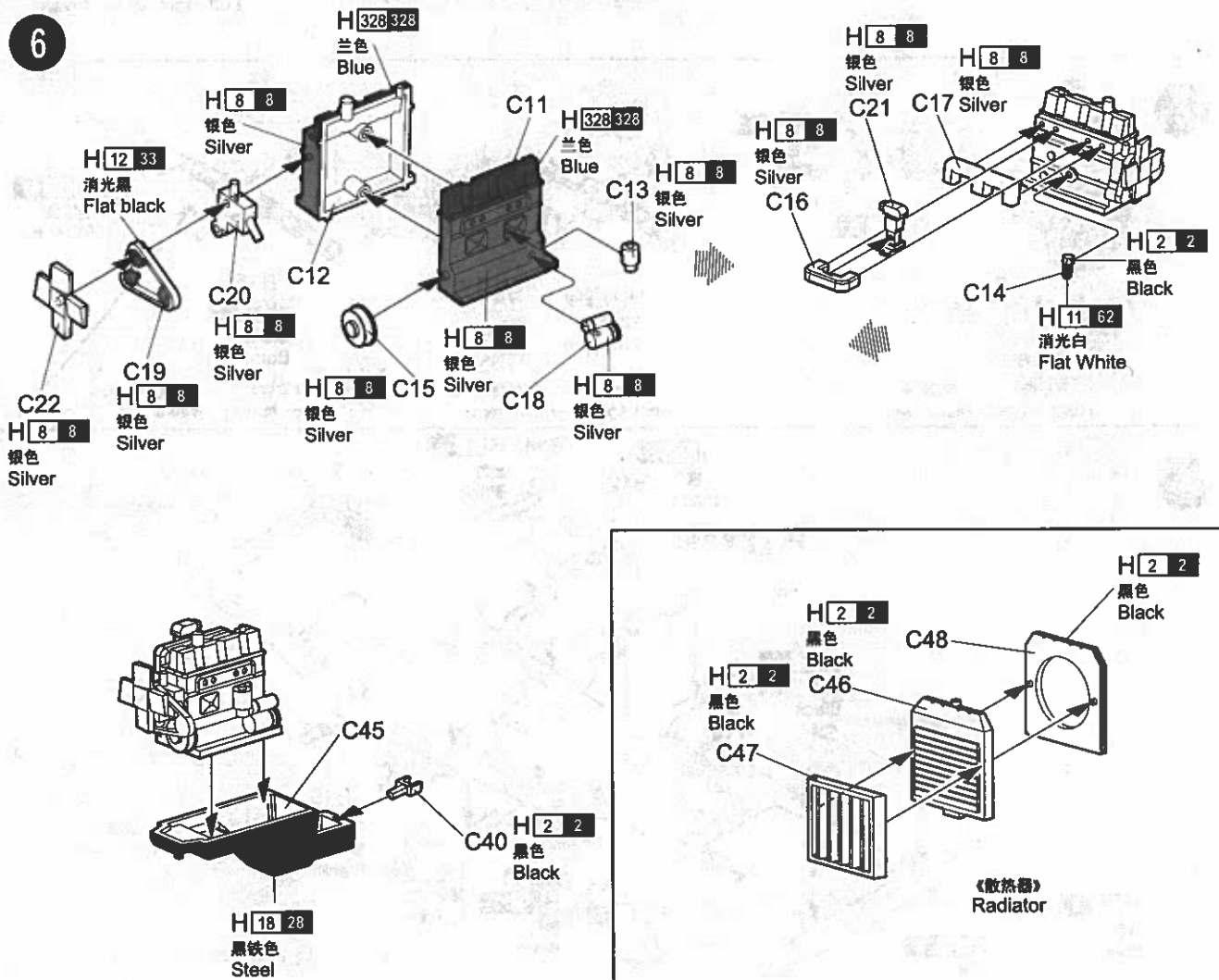

7

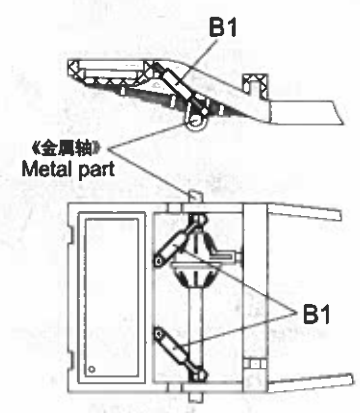
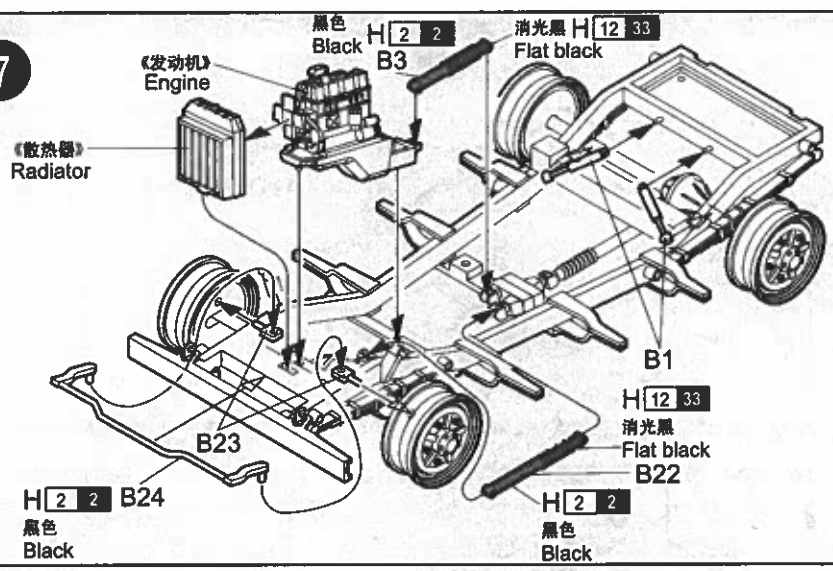

8

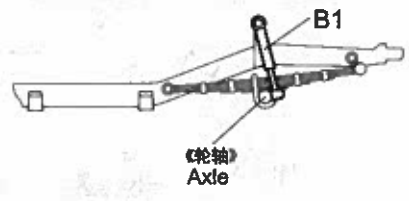
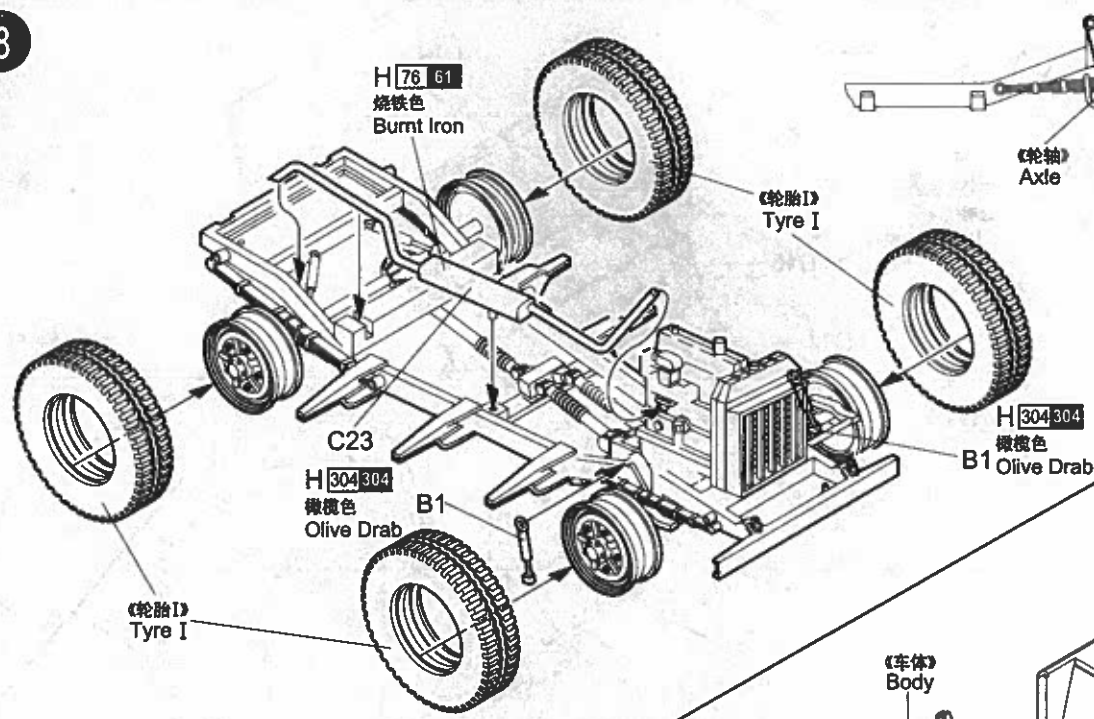

9

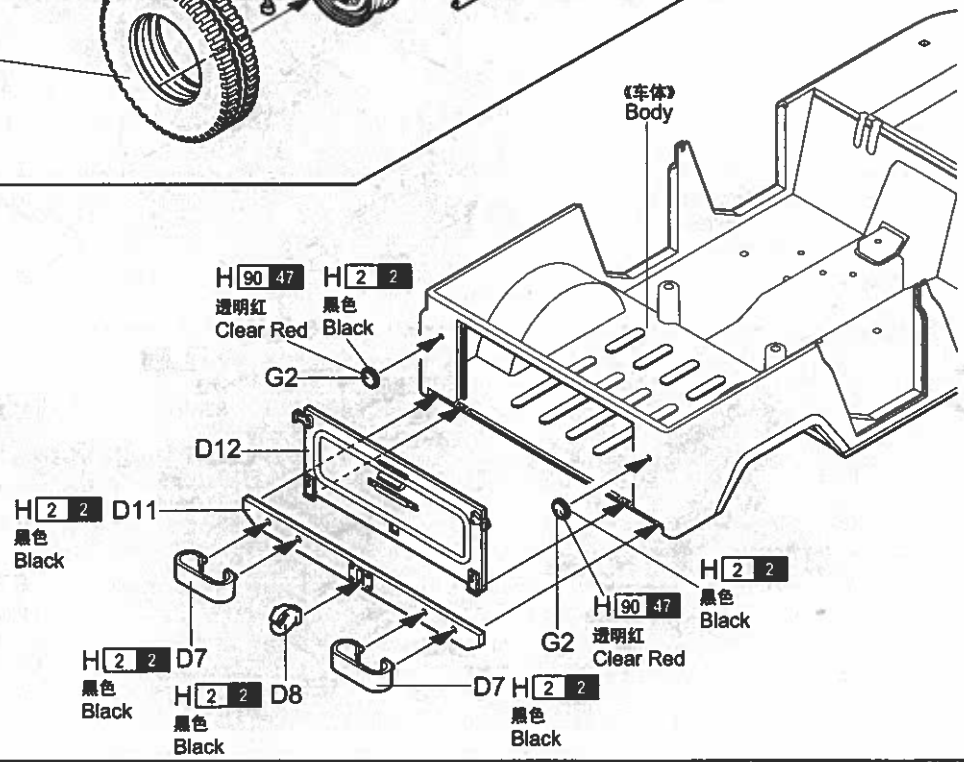

10

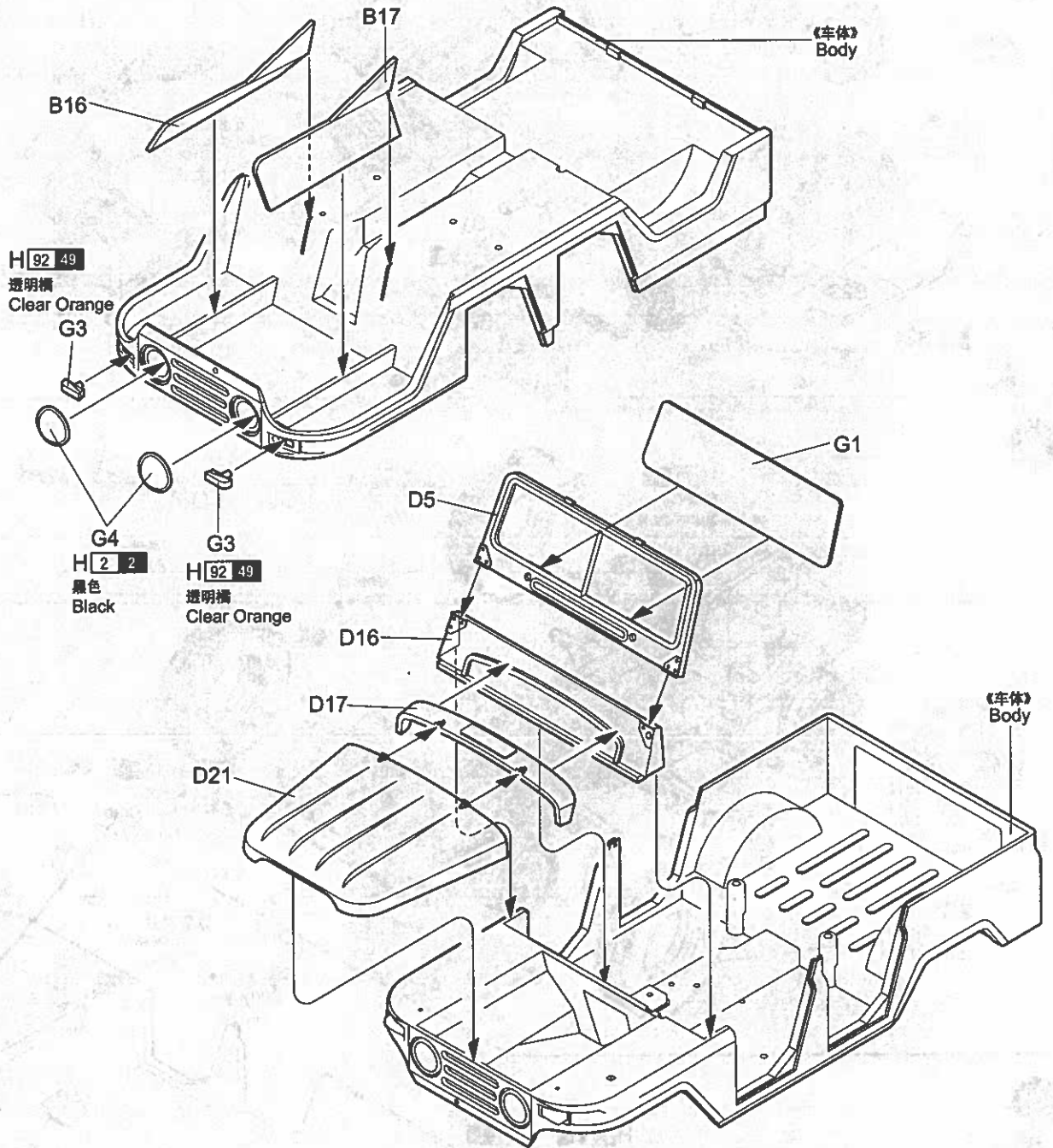

11

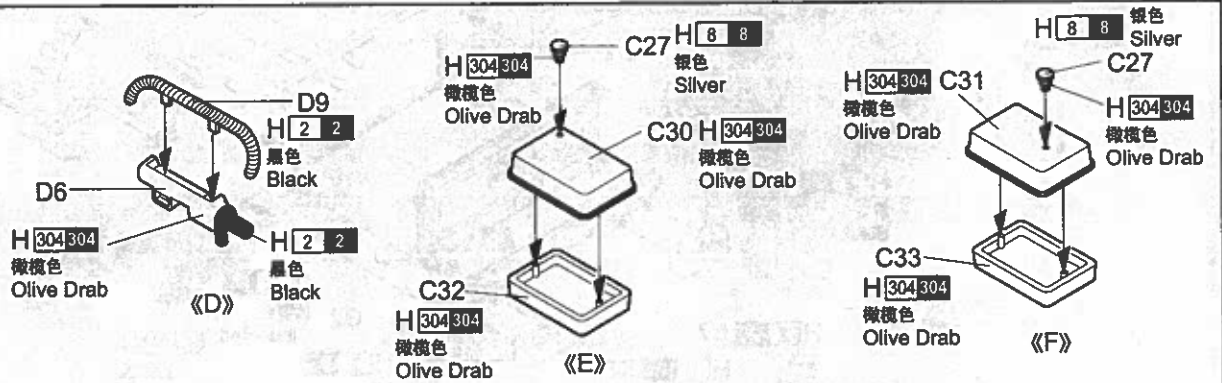

12

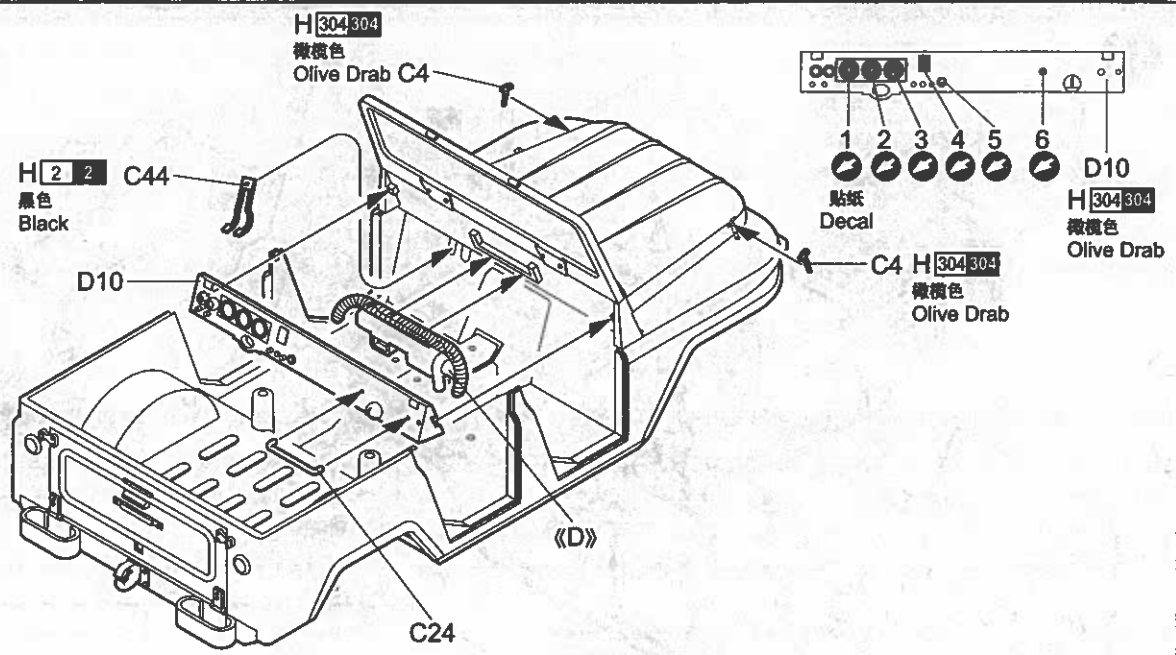

13

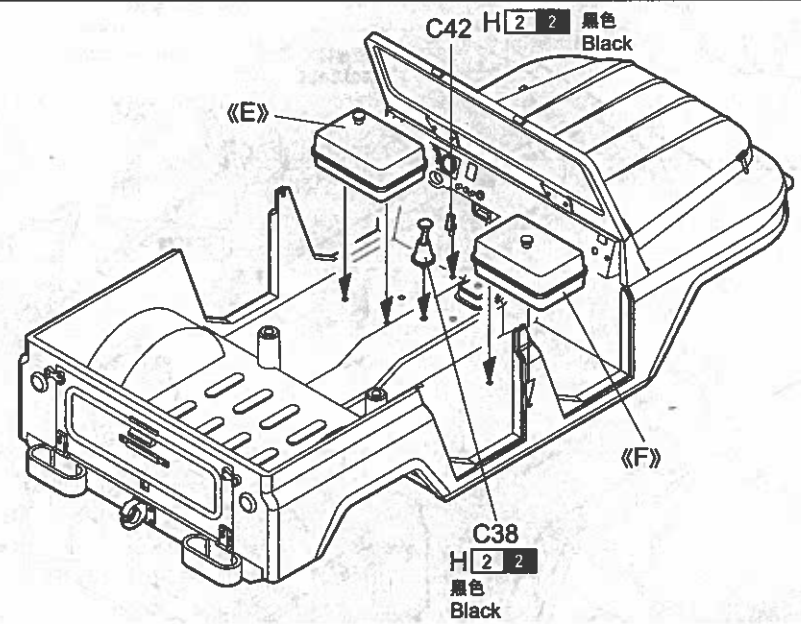

14

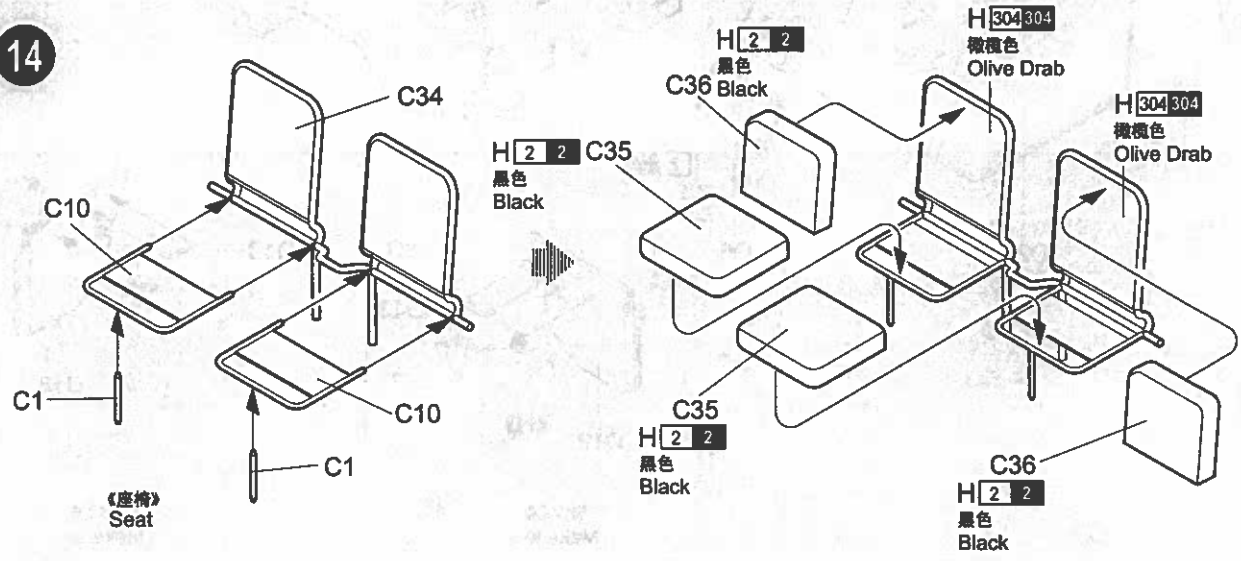

15

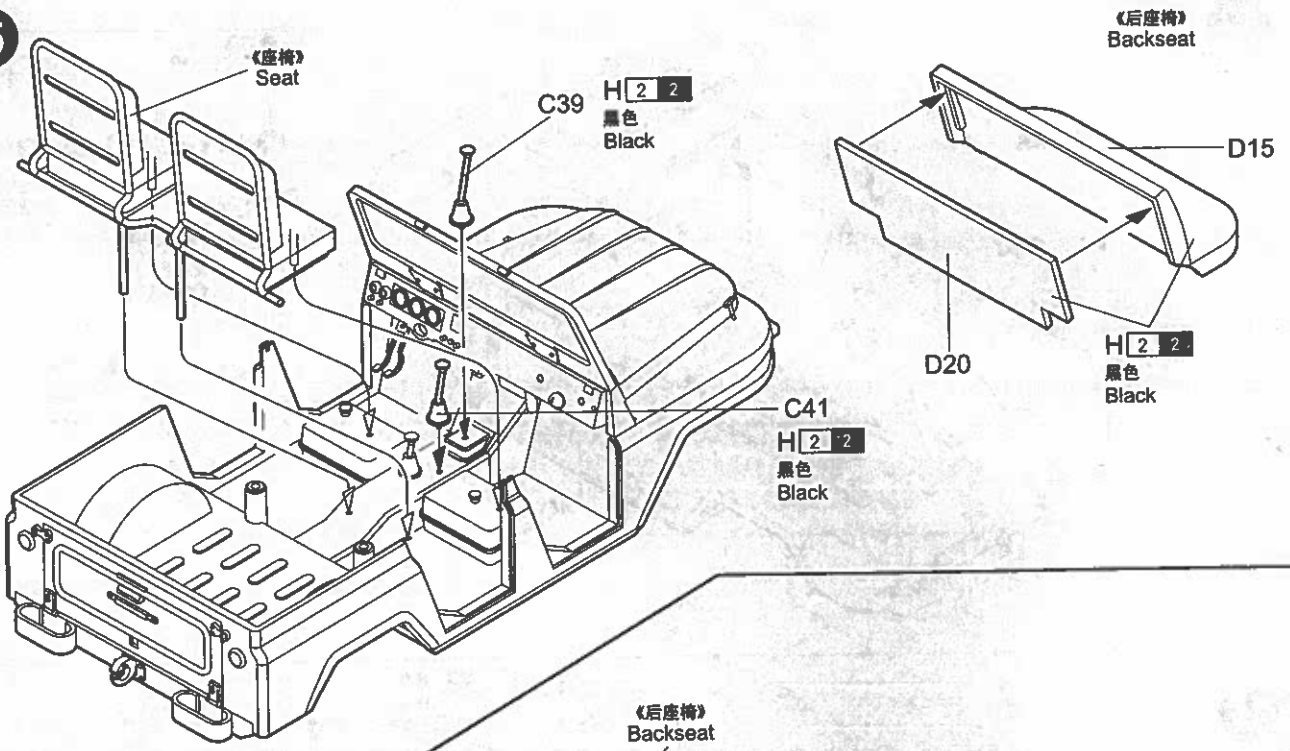

16

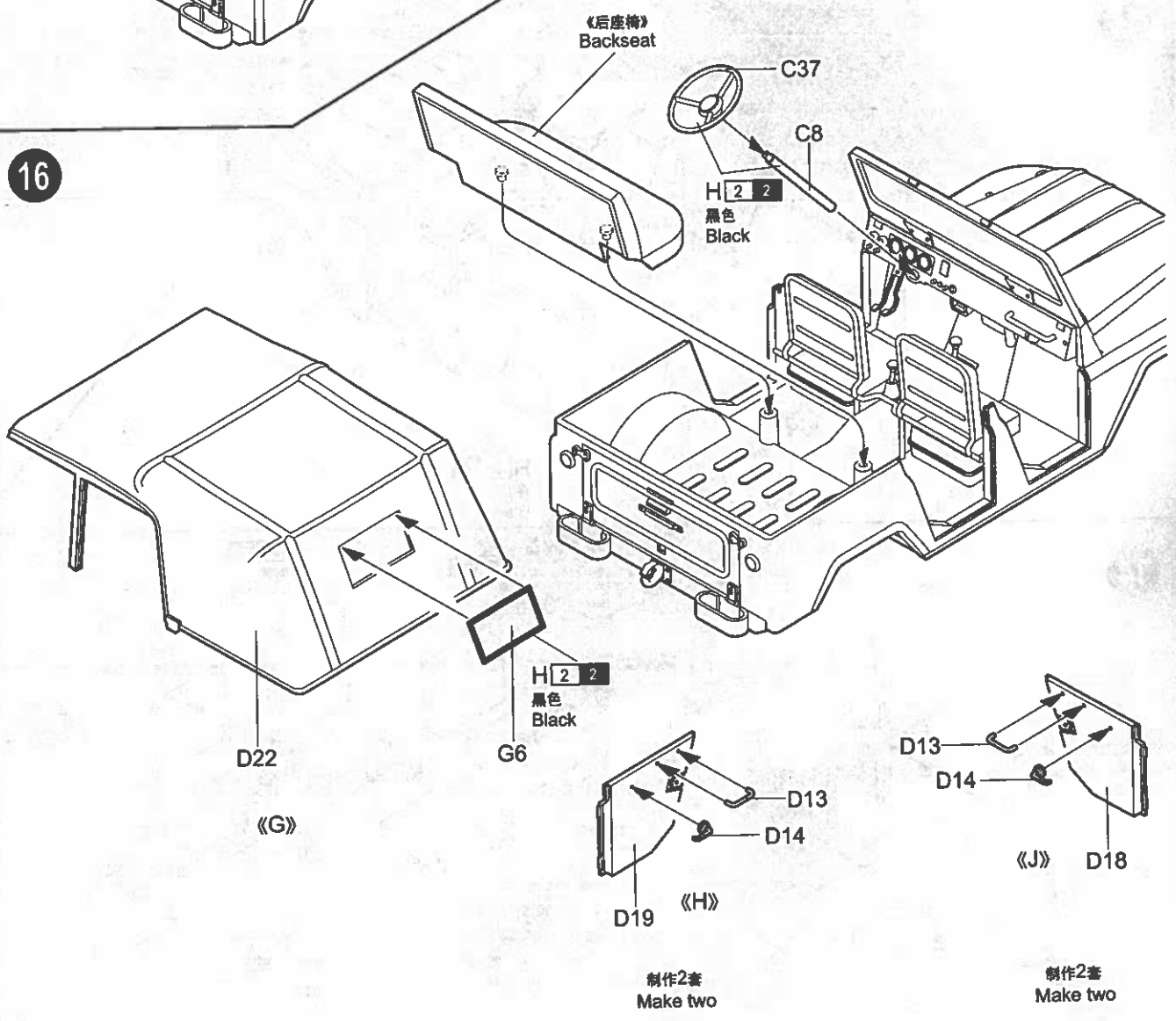

17

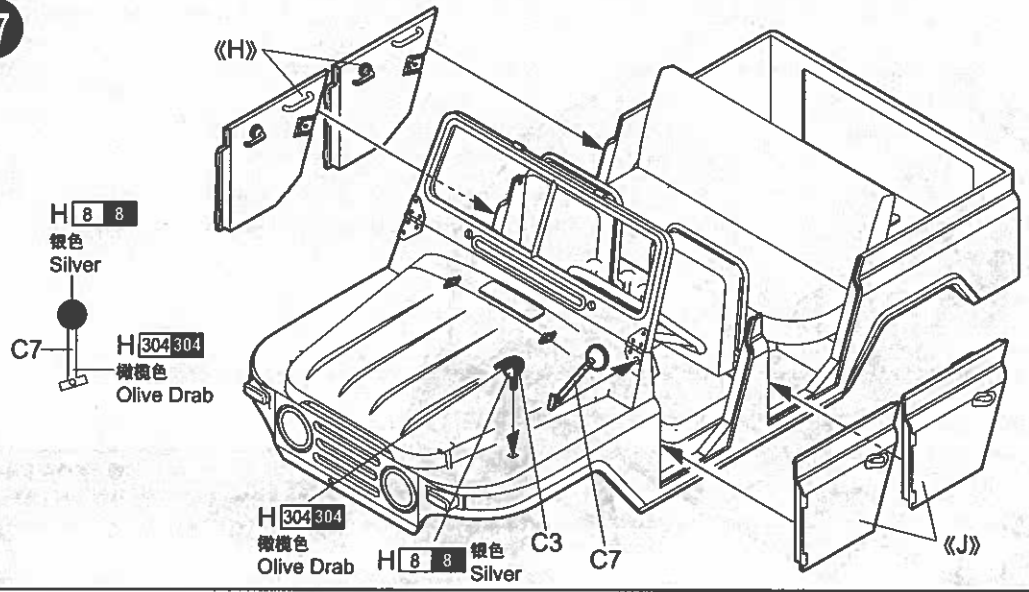

18

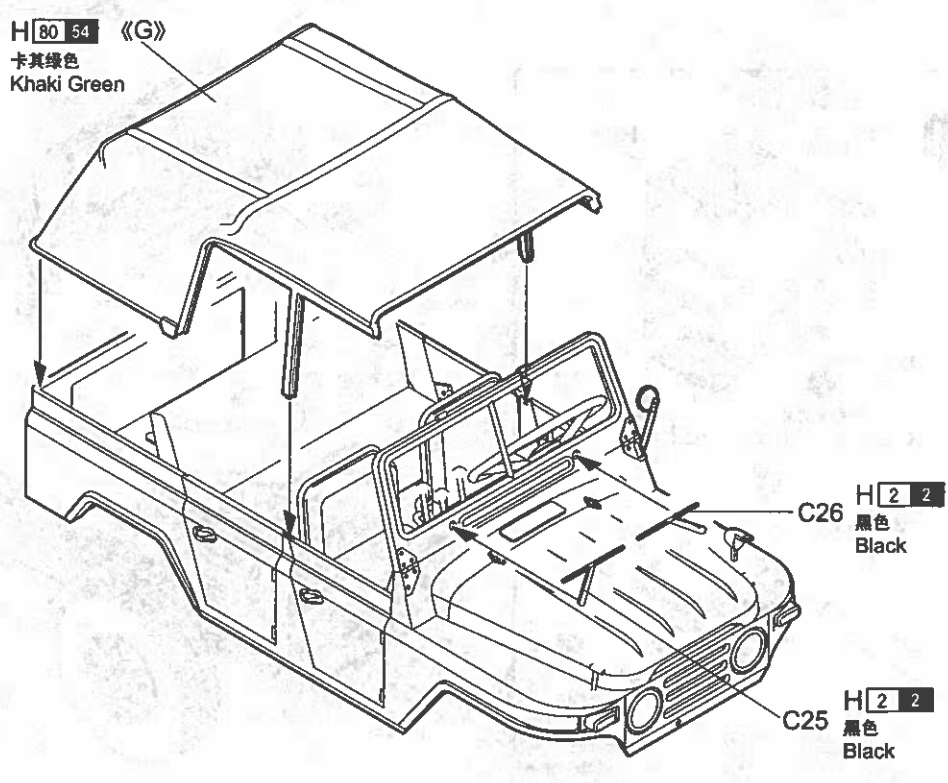

19

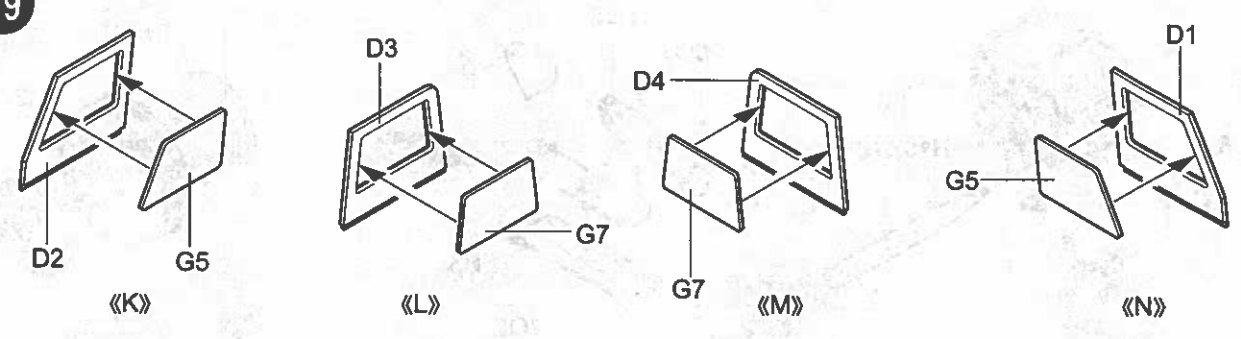

20

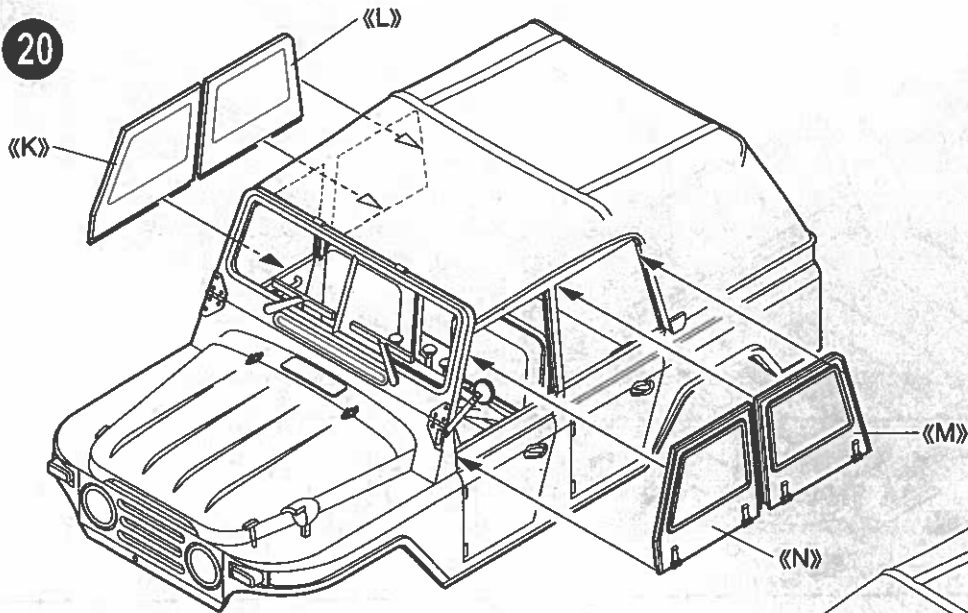

21

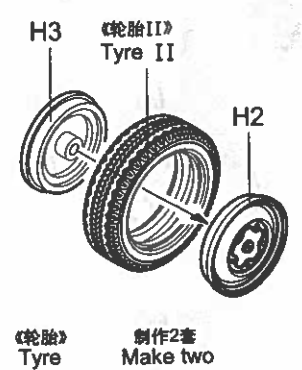
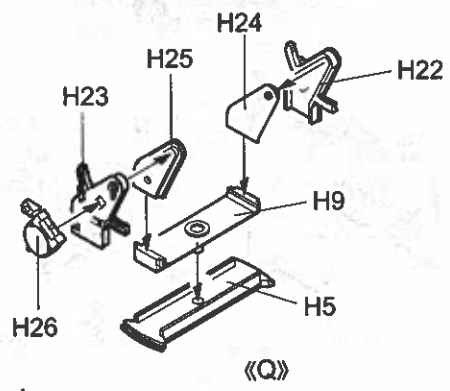
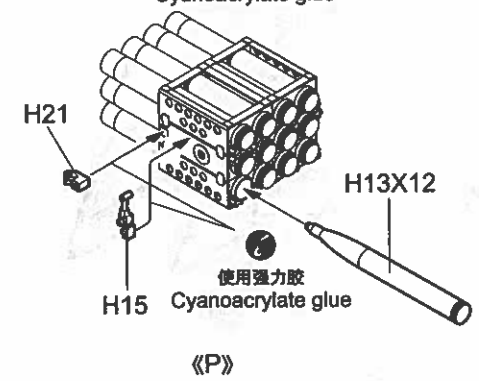
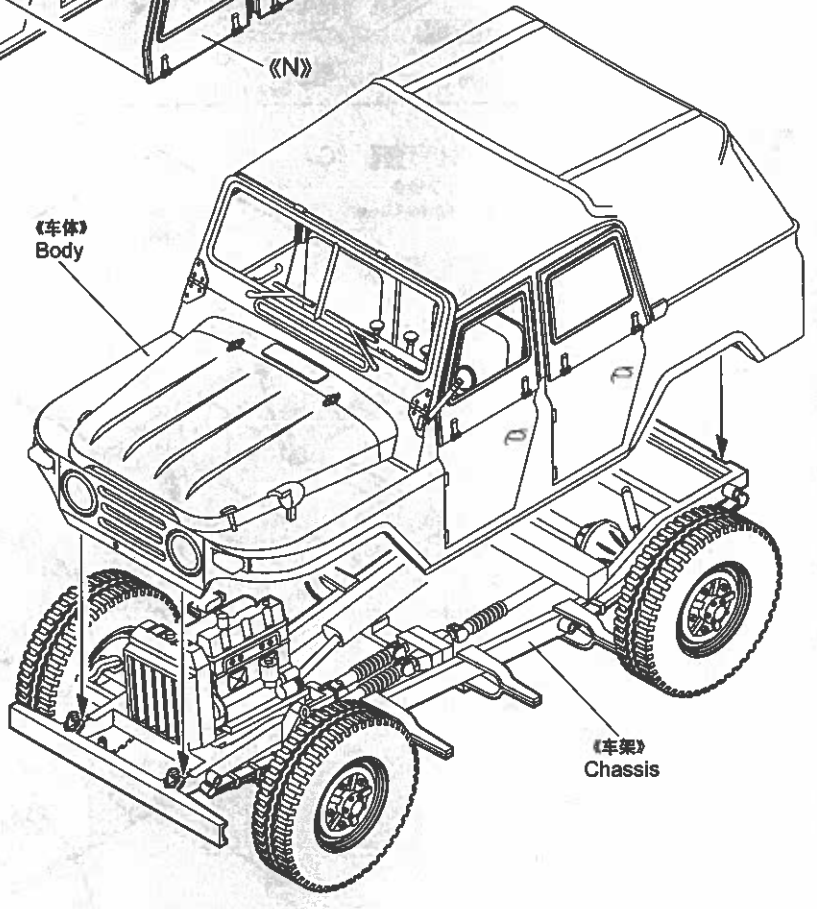
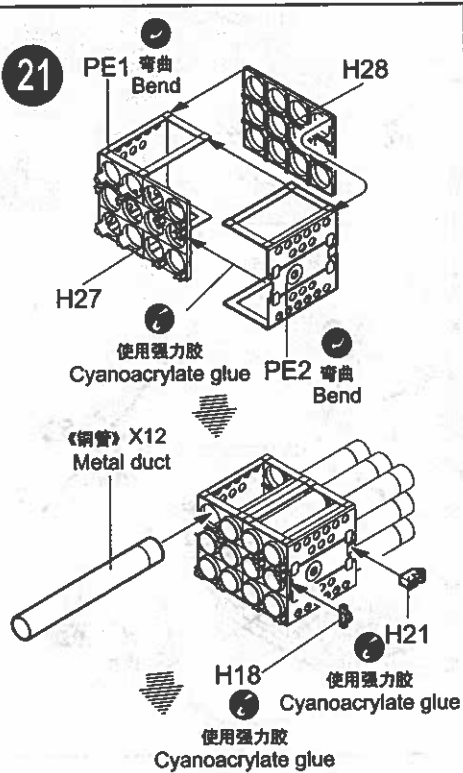

\*火箭炮可选择运输状态和战斗状态  
Rocket can be built in transport or combat position

\*战斗状态请参照步骤22、25、26  
Combat Position refer to Step 22、25、26

22

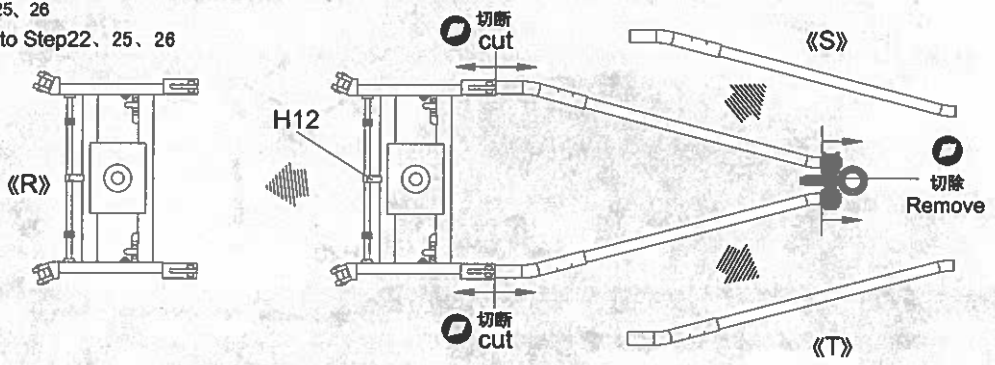

\*运输状态请参照步骤23、24  
Transport Position refer to Step 23、24

23

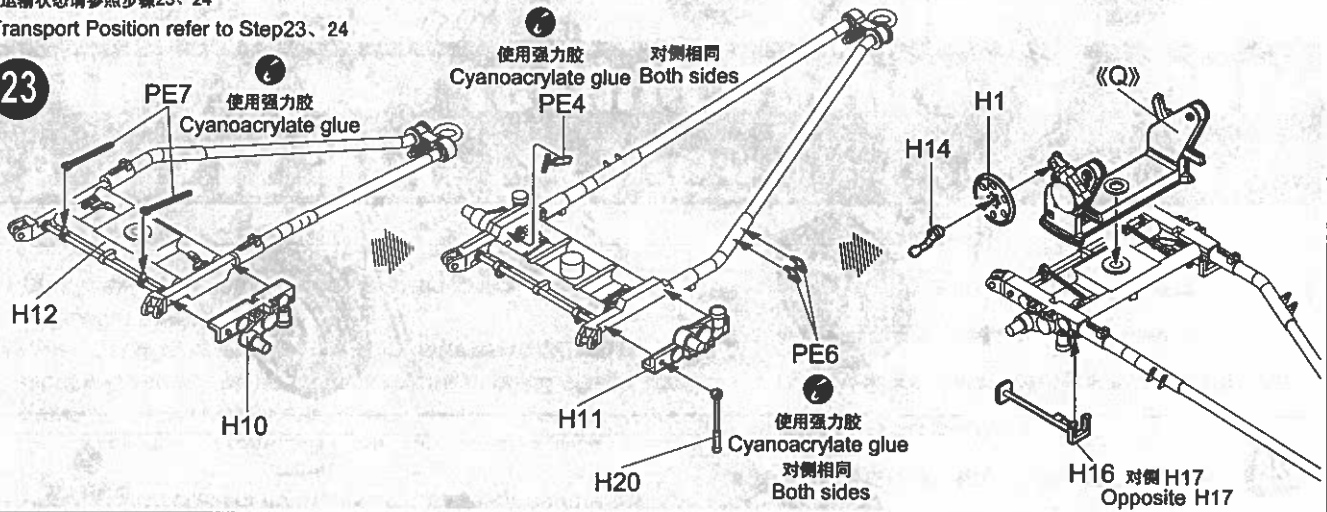

24

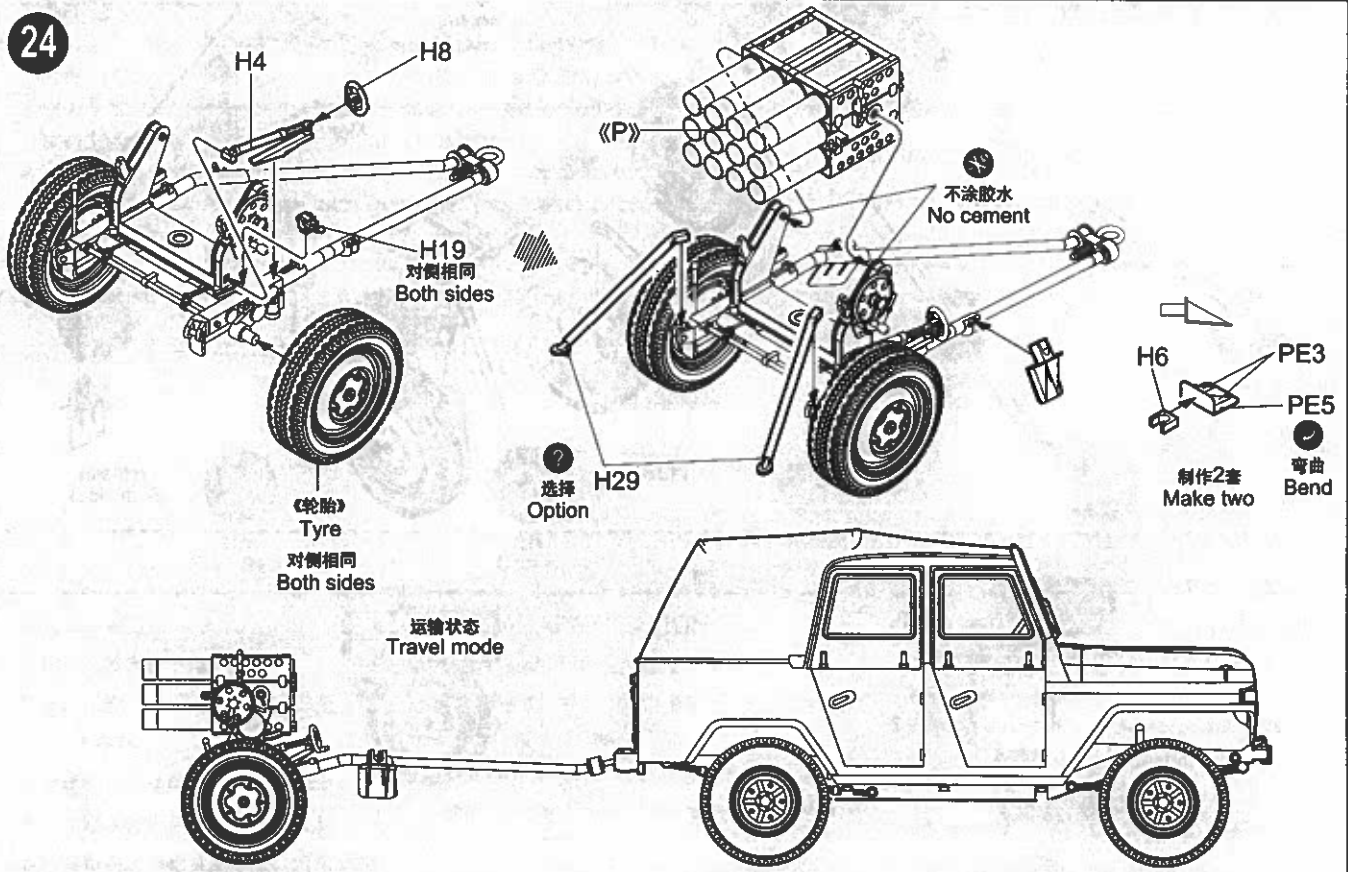

25

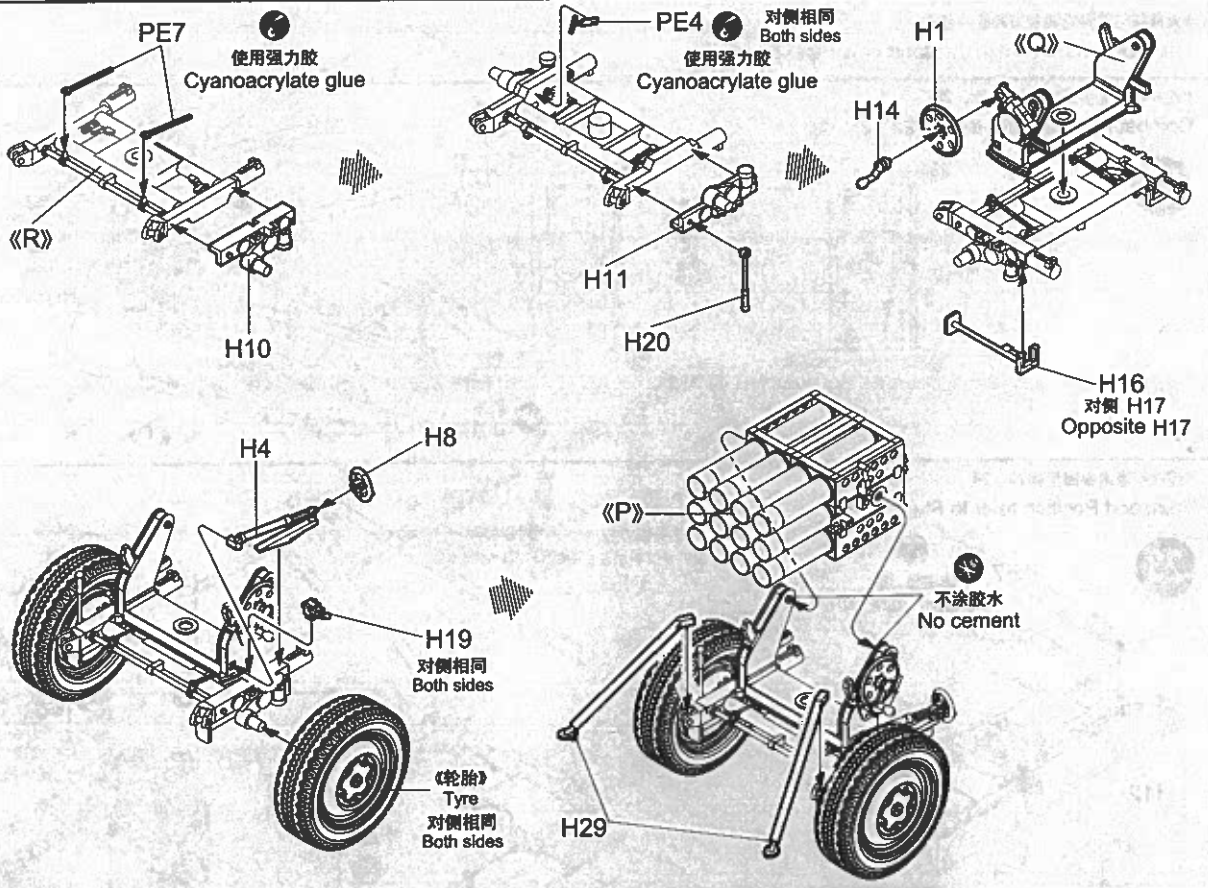

26

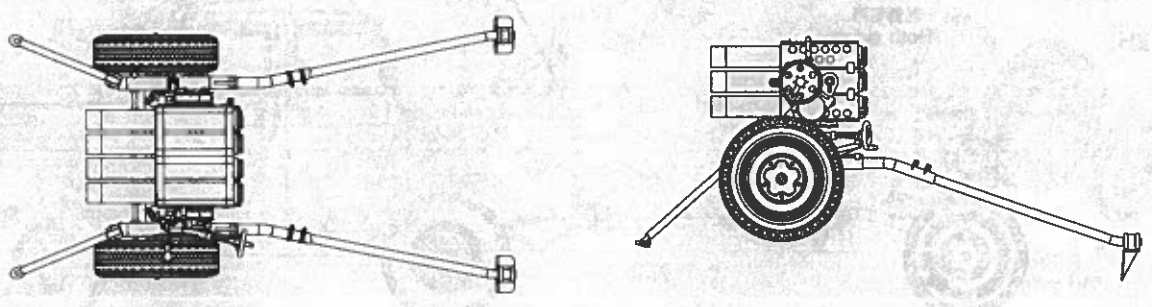
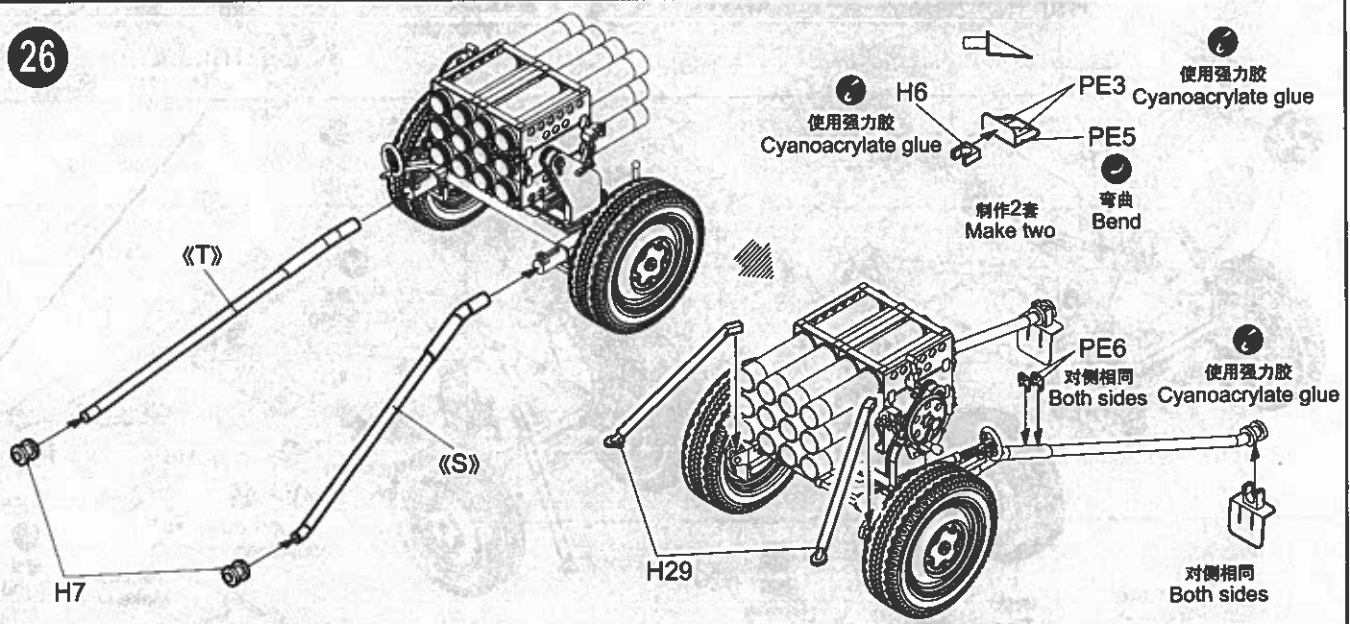

# 涂装同标贴指示

## Painting & Marking guide

### PAINT REFERENCE COLOUR

Color	Mr.Hobby	Vallejo	Model Master	Tamiya	Humbler
Flat Black	H[77] 137	—	—	—	—
Light Green	H[303] 303	—	1713	XE20	117
Dark Green	H[305] 305	883	1740	XF50	118
Shiny Silver	H[3] 3	987	1546	X11	11
Shiny Black	H[18] 18	884	1402	—	—

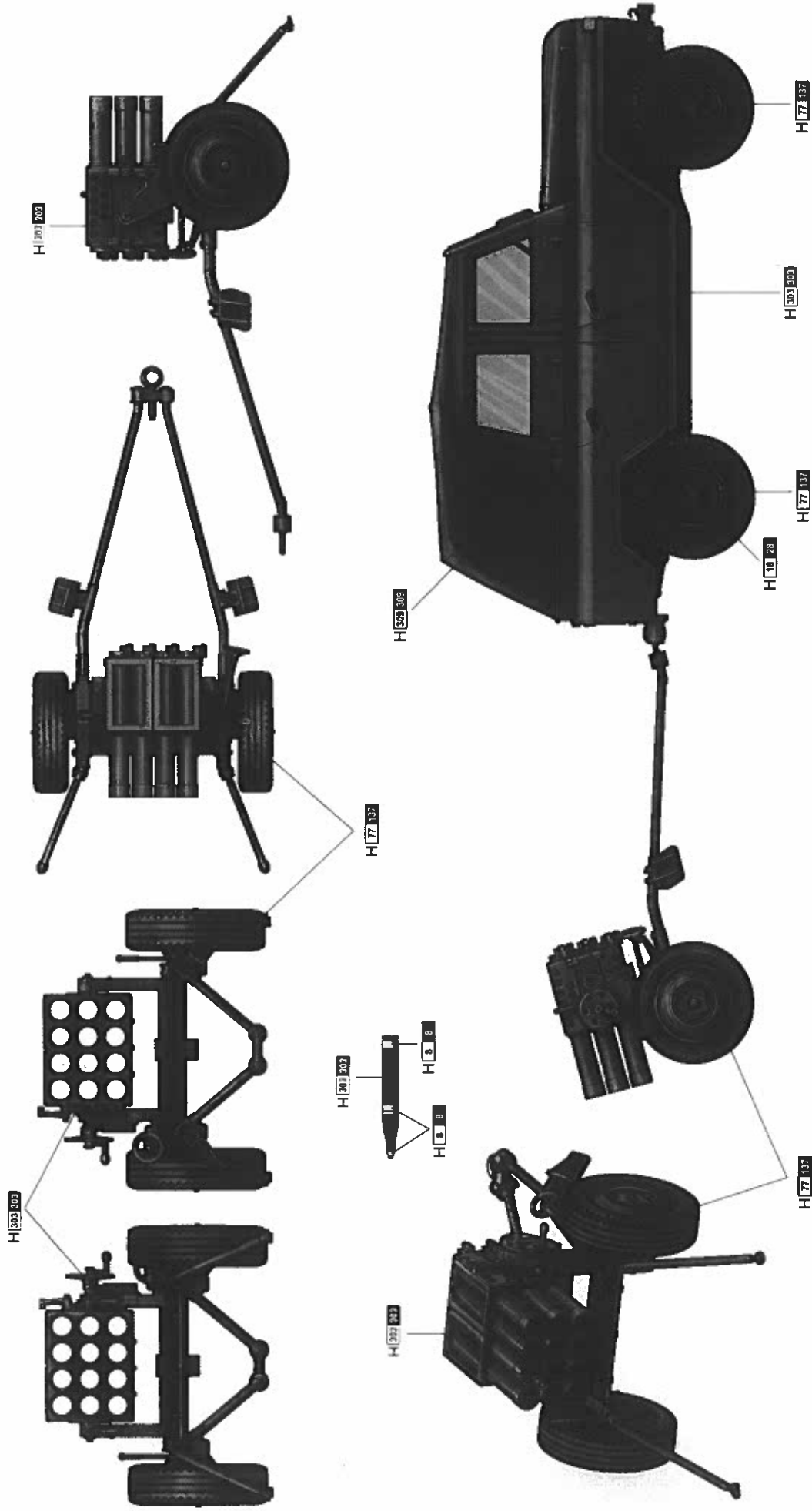

H[ ] AQUEOUS HOBBY COLOR ■ Mr. COLOR

02320 1/35 PLA Type 63 107mm Rocket Launcher & BJ212 Military Jeep