

US NAVY A-7E Corsair "II"

1:32 SCALE

美国海军A-7E"II"型舰载攻击机

READ BEFORE ASSEMBLY

- Study and understand these instructions thoroughly before beginning assembly. Make sure all parts are included by comparing them to those shown on pages 2 to 5 of these instructions.
- Remove parts from sprues as needed, and trim excess with a hobby knife. Be careful not to lose small parts.
- Remove photo-etch parts from sprue as needed using a hobby knife or photo etch cutter.
- Apply cement to photo etch parts as shown on instructions. Applying too much cement will restrict the operation of these

movable parts. Apply cement carefully! Removed photo etch parts can have sharp edges. Take care when handling these to avoid injury.

- Apply decals to necessary parts prior to assembly.
- Additional tools recommended(not included):Sprue cutter, Long nose pliers, hobby knife, file, tweezers, pin vise, scissors, cement, sandpaper, soft cloth, glue and paint.
- Keep all parts out of reach of children, as they pose a choking hazard. Discard all unnecessary bags and sprues when model is completed to avoid accidental injury.

装配之前仔细阅读

- 小心用模型锉刀锉平所有零件表面的注射浇口。
- 小心用刀片切下蚀刻片零件，不要遗失小零件。
- 用强力快干胶水粘合蚀刻片零件和金属轴。过量的快干胶水使用可能导致可动零件会粘住，小心涂胶。
- 取蚀刻片时应特别注意安全，防止利边划伤手指。
- 某些零件表面需贴上水贴纸，请选择在装配的同时进行。
- 推荐模型工具(自备)：胶水，水口剪刀，长咀钳，刀片，锉刀，镊子钳，钻，剪刀，瞬间快干胶。
- 软布同砂纸同时也应该是必备工具。
- 请使用塑料胶水和油漆，模型内不含。
- 谨防小孩吮吸塑料零件，或者将塑料袋套在头上，制作时应将套材远离小孩接触。

水贴纸的使用:

1. 从水贴纸上剪下印花;
2. 将印花放入温水中浸10秒, 然后放在干净布上。
3. 拿着印花纸板将印花移到模型上;
4. 手指蘸水将印花移到适当的位置;
5. 用软布轻压印花直至水干, 汽泡消失。

DECAL APPLICATION

1. Cut off decal from sheet.
2. Dip the decal in tepid water 40°C for about 10 sec. and place on a clean cloth.
3. Hold the backing sheet edge and slide decal onto the model.
4. Move decal into position by wetting decal with finger.
5. Press decal gently down with a soft cloth until excess water and air bubbles are gone.



cyanoacrylate glue
使用强力胶



weight
配重



make hole
钻孔



cut / remove
切除



option
选择



no cement
不涂胶水



decal
贴纸



bend
弯曲



file / sand
锉平

部品图 Parts

A × 1

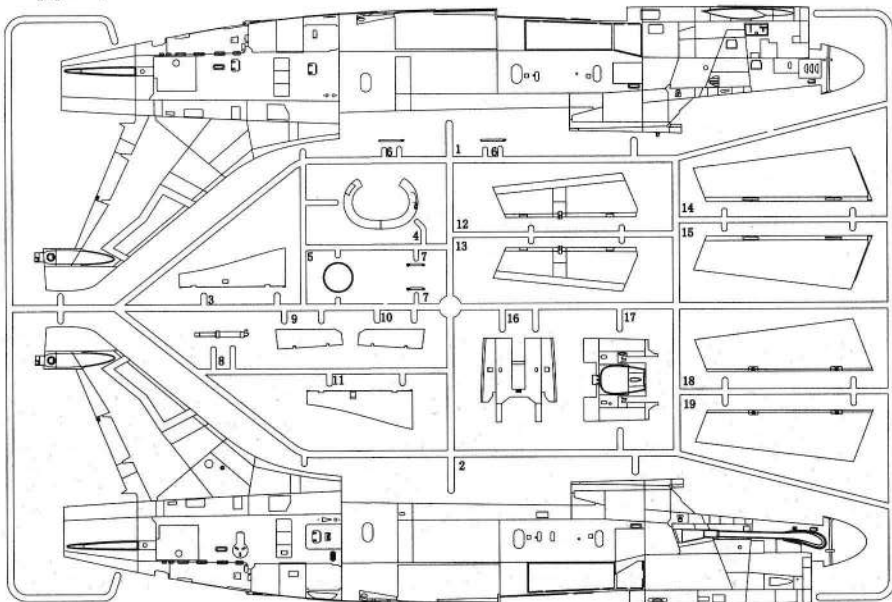

B × 1

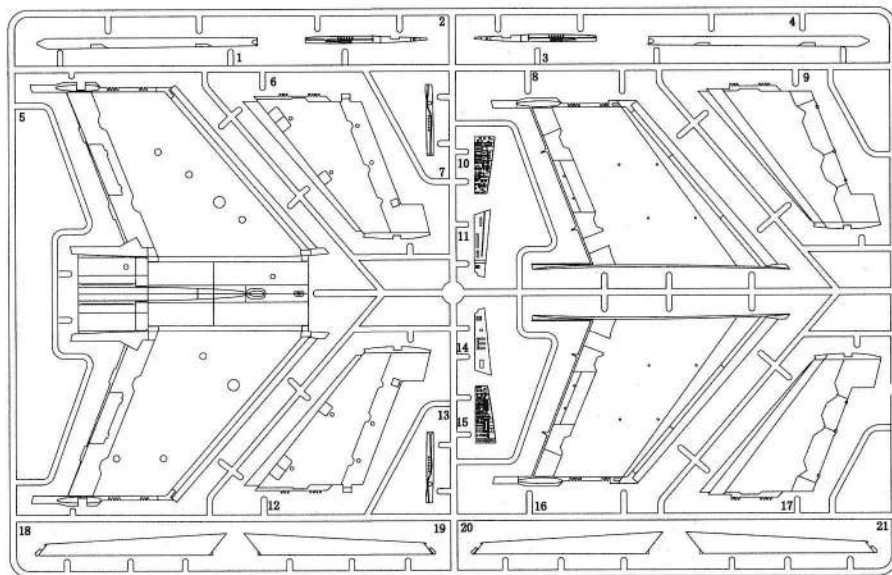

C × 1

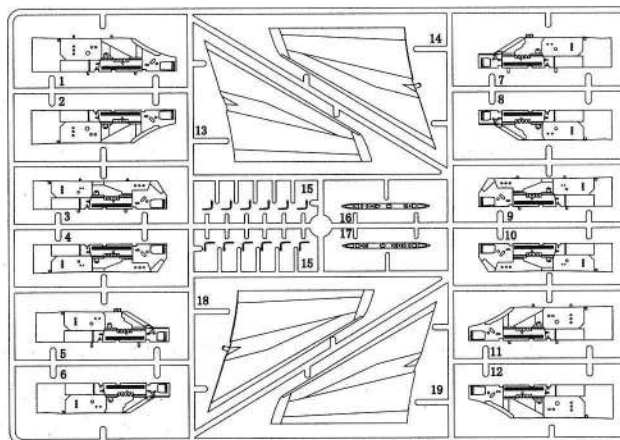

D × 1

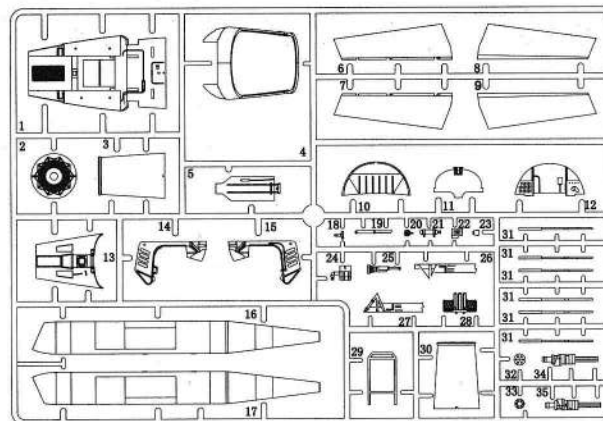

K × 1

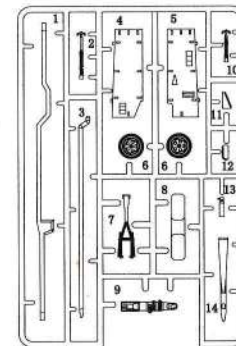

J1 × 2

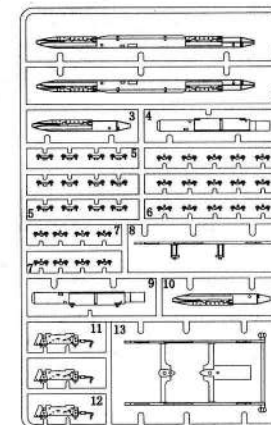

J2 × 2

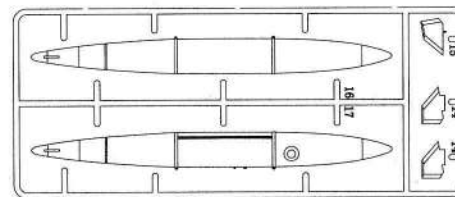

风挡
Windscreen



座舱罩
Canopy



L × 1

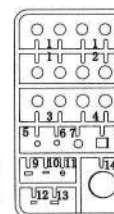

E × 1

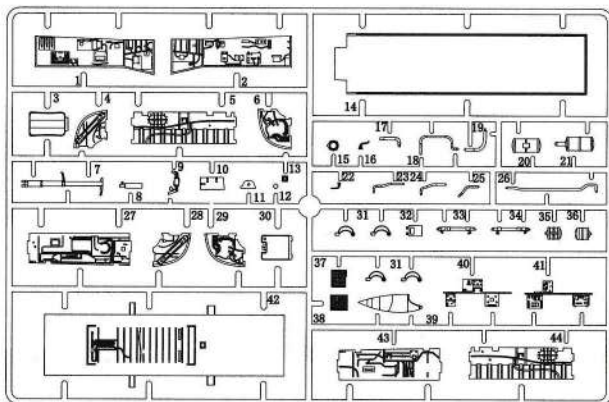

F × 1

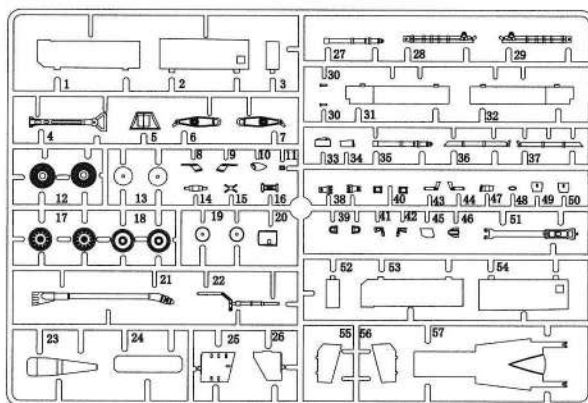

G × 2

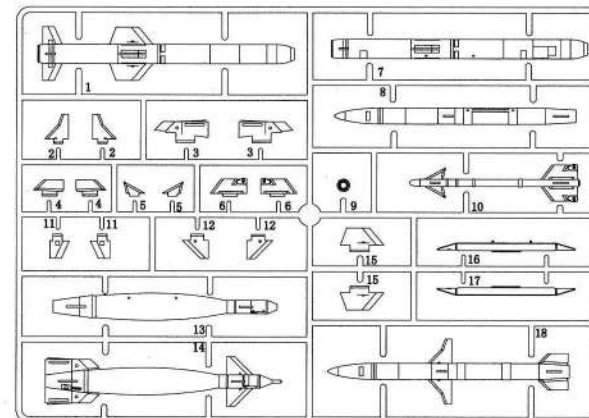

H × 6

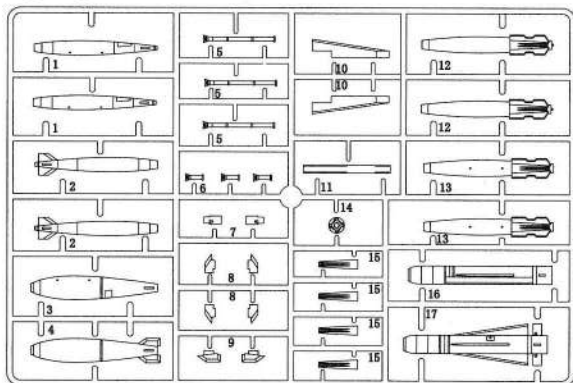

I × 2

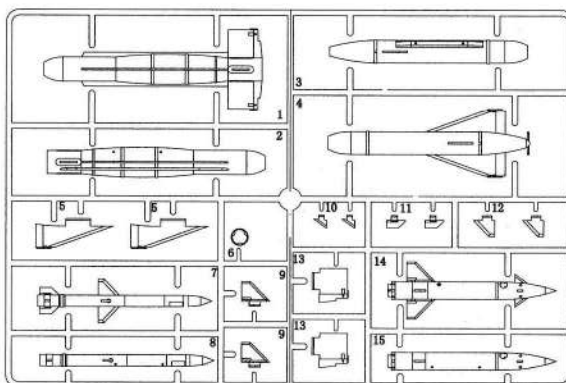

不用部件 : D5,D14,D15,D20,D29,E3,E30,G1,G2,G4,G7,G8,G11,
Unused parts G15,G18,J4,J9,K8,K14,L3,PE1,PE2,PE3,PE4,F24

主轮胎
Main tire



前轮胎
Nose tire



菲林片
Film part

《贴纸》
Decal

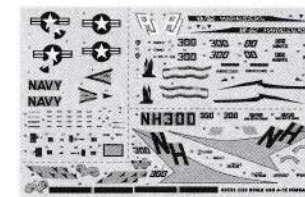

N

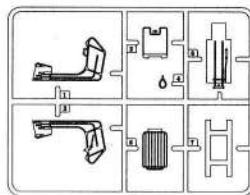

蚀刻片
Photo Etched Parts(PE)

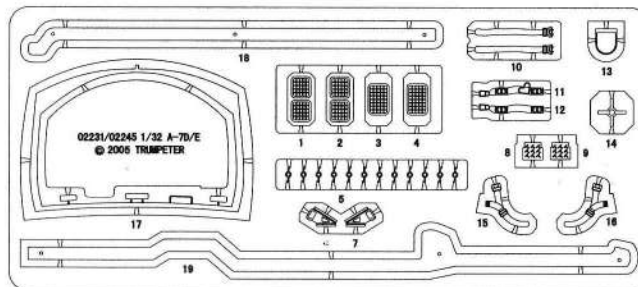

1 座椅的组装
Pilot seat assembly

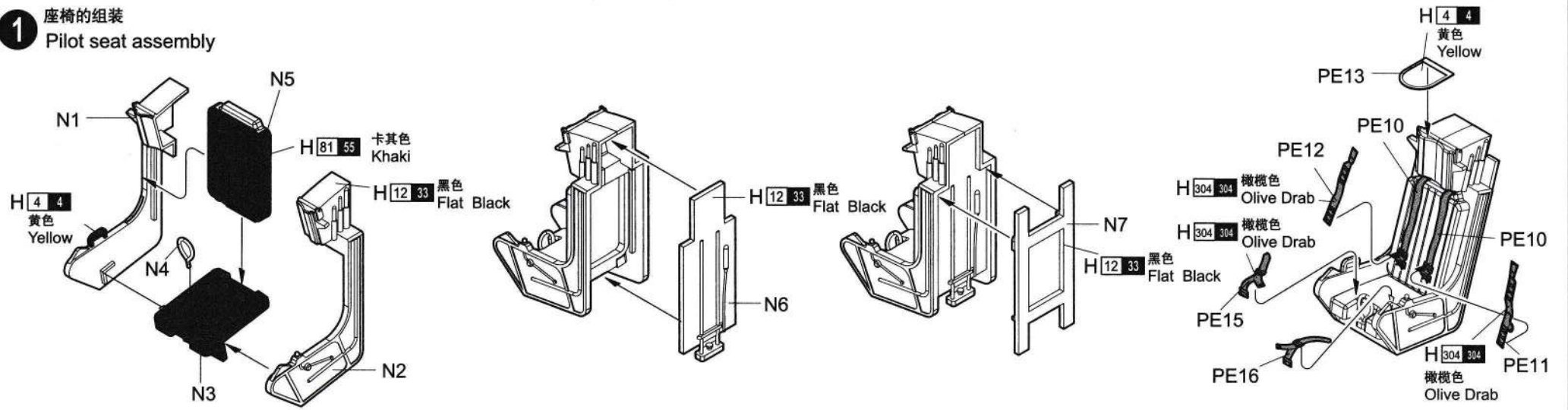

2 座舱的组装
Cockpit assembly

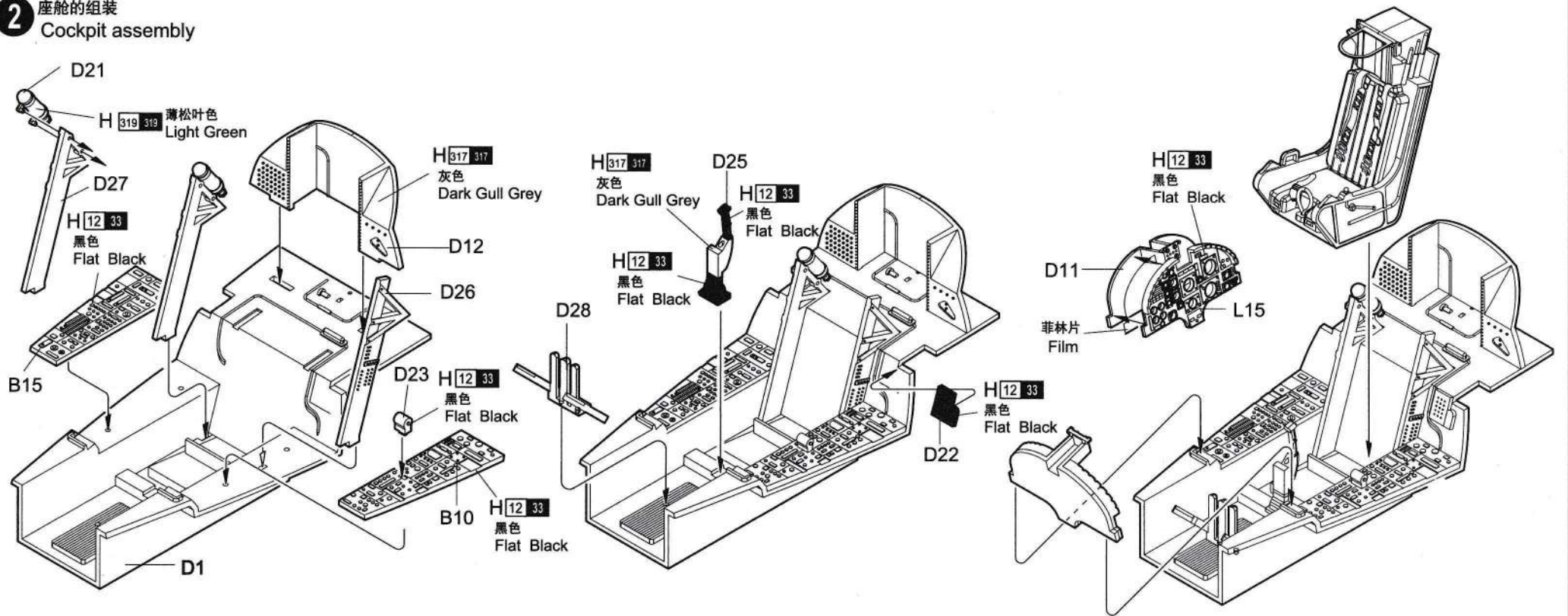

3 左侧主轮舱的组装
Left main gear cabin assembly

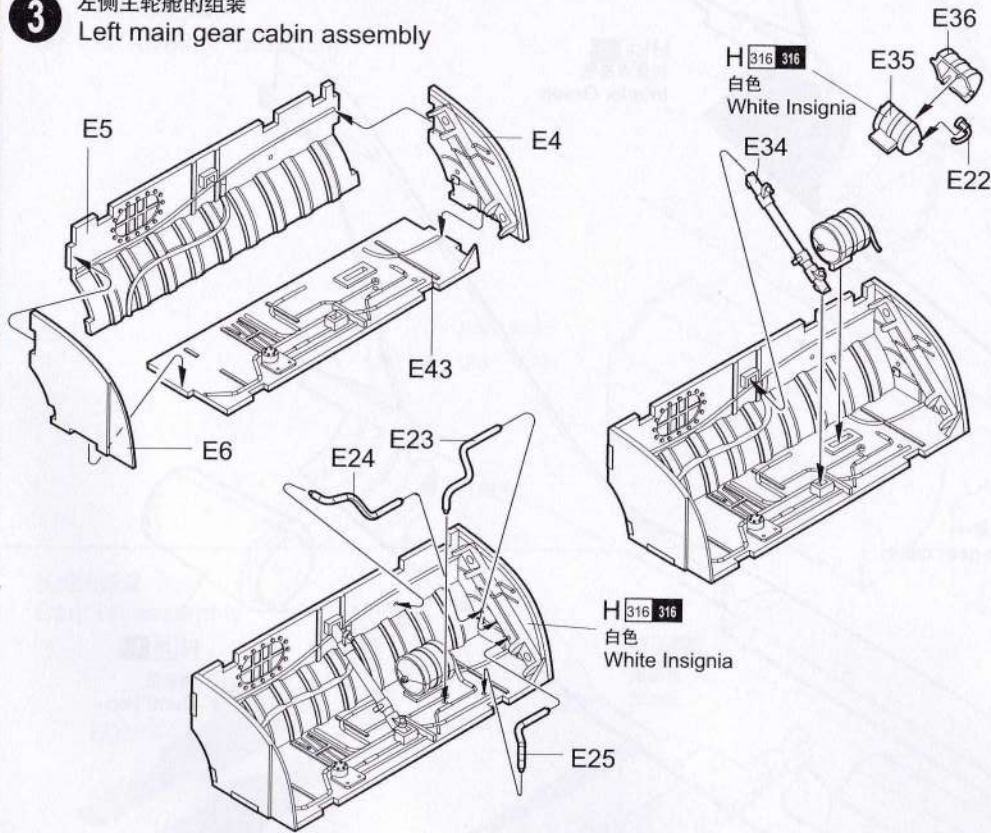

4 右侧主轮舱的组装
Right main gear cabin assembly

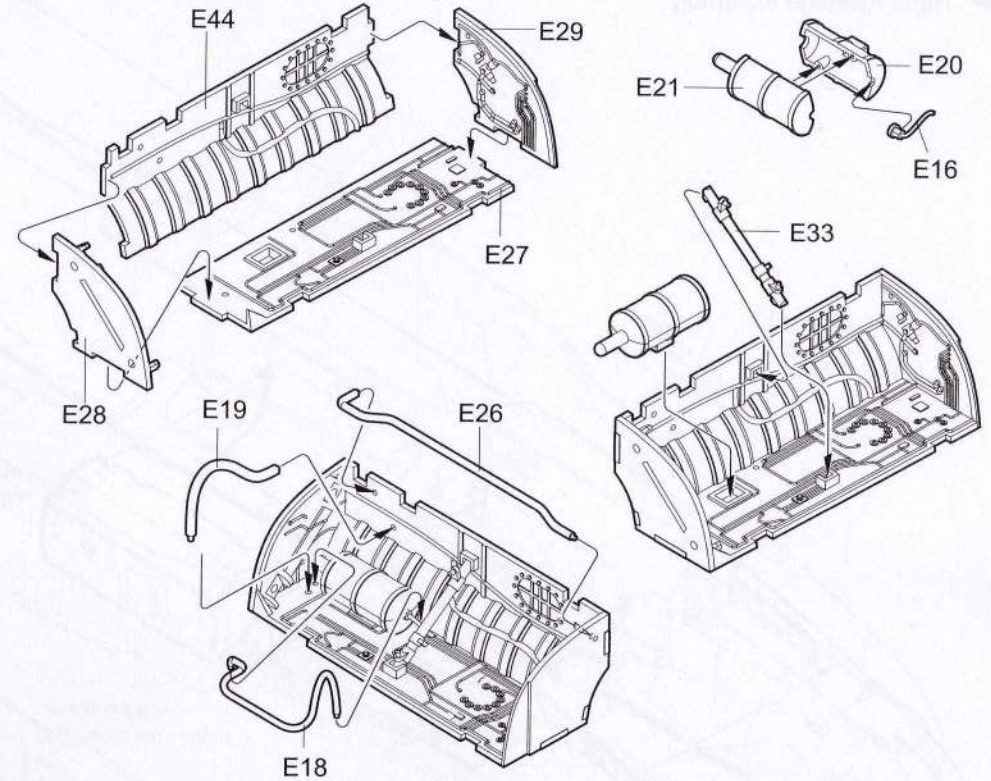

5 左侧主轮舱的组装
Left equipment cabin assembly

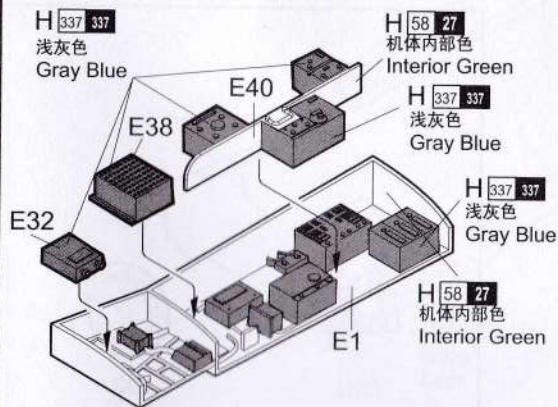

6 右侧主轮舱的组装
Right equipment cabin assembly

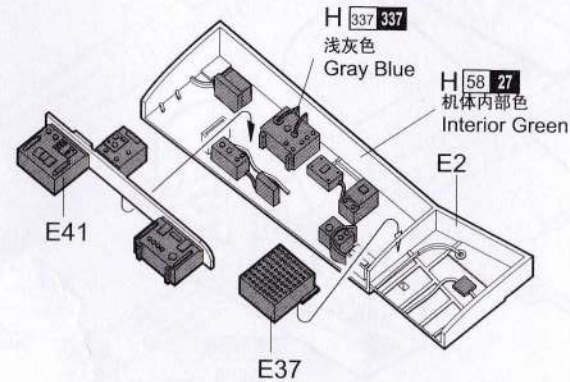

7 前轮舱的组装
Nose gear cabin assembly

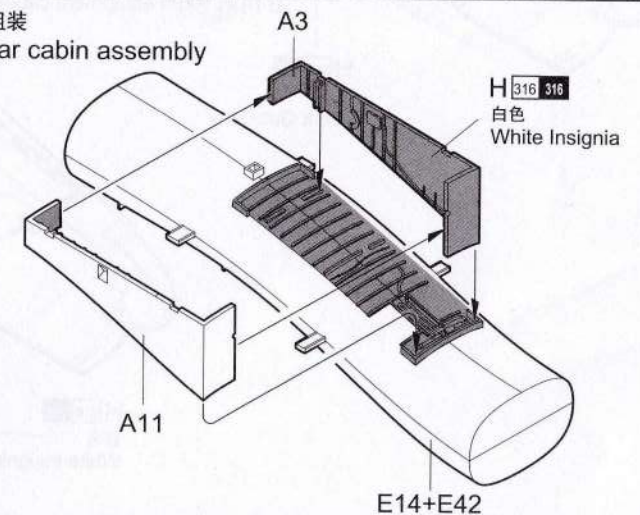

8 右侧机身的组装
Right fuselage assembly

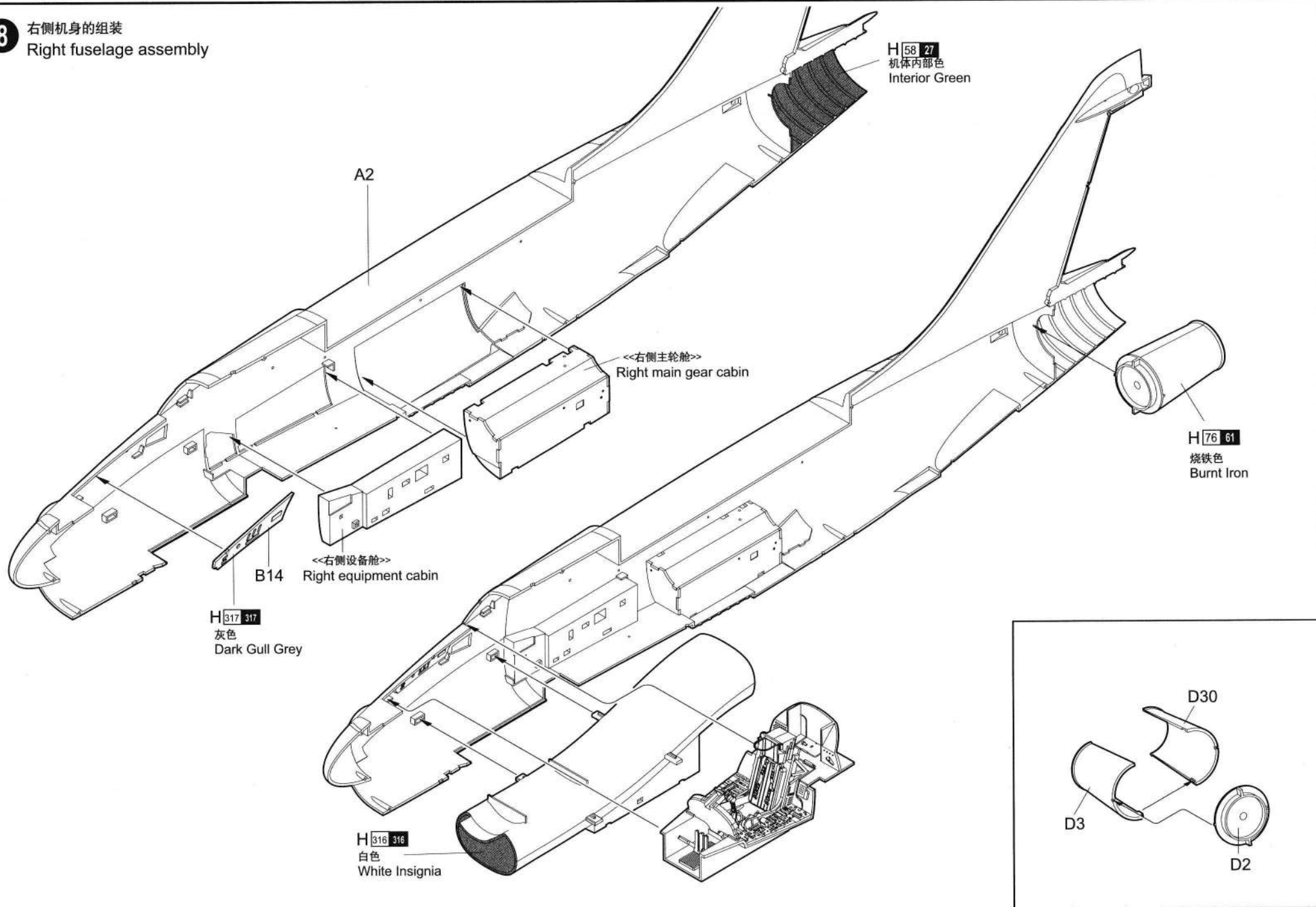

9 左侧机身的组装
Left fuselage assembly

<<左侧主轮舱>>
Left main gear cabin

A1

H 317 317
灰色
Dark Gull Grey

B11

<<左侧设备舱>>
Left equipment cabin

机炮的组装
Cannon assembly

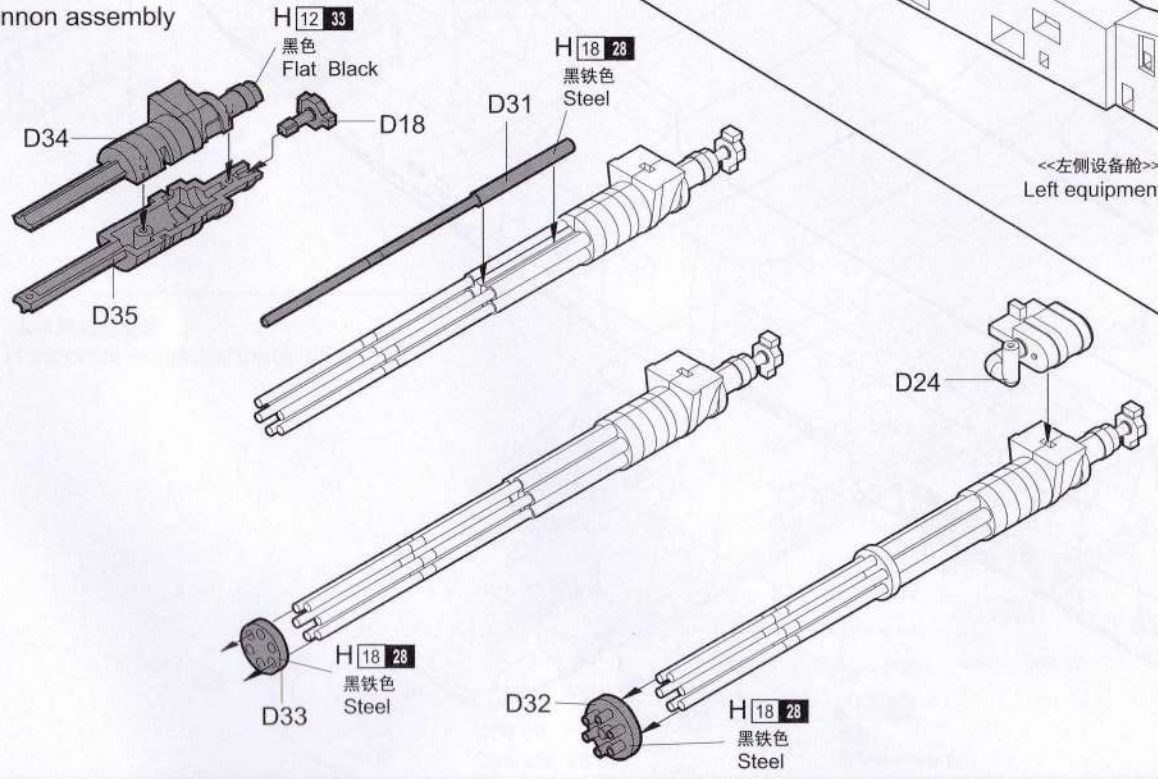

10 机身的组装
Fuselage assembly

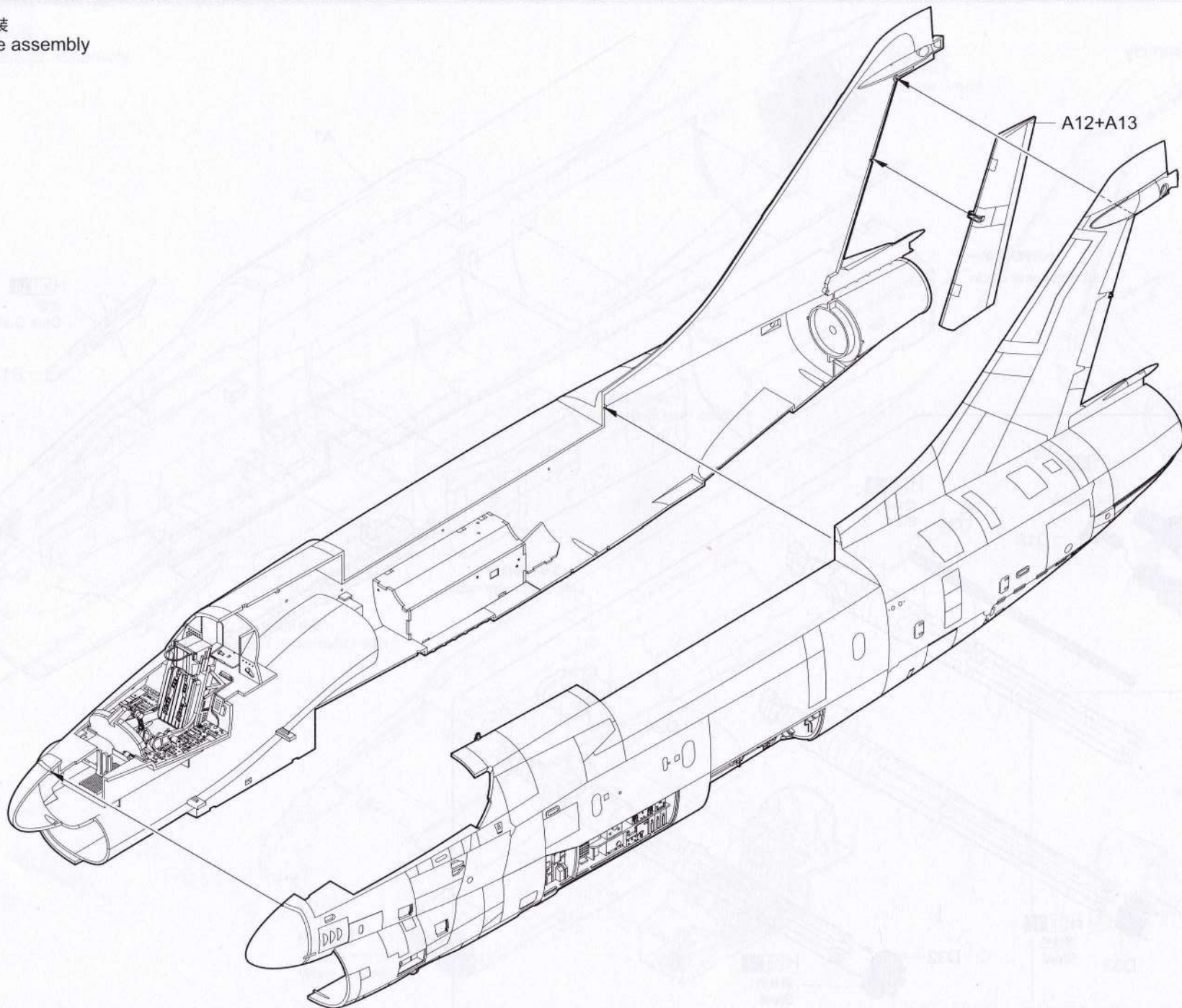

11 机腹
Lower fuselage

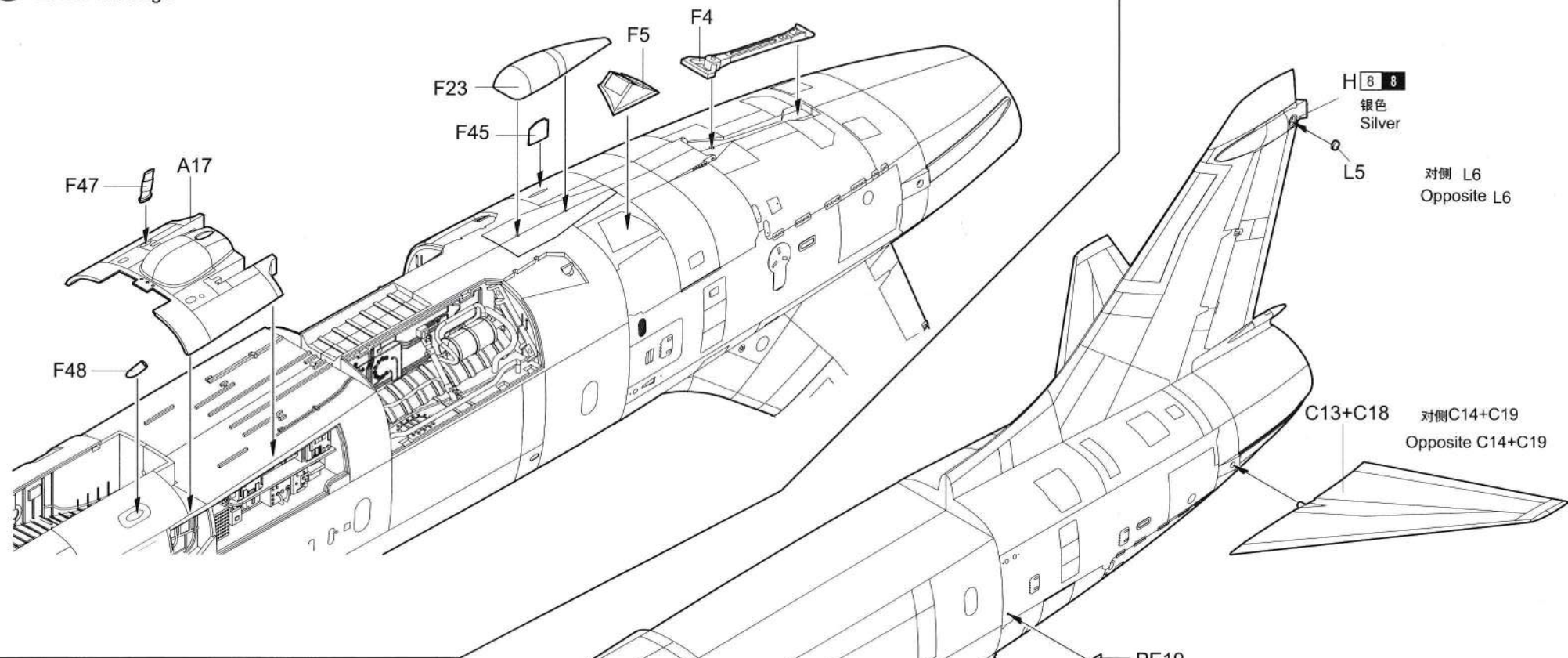

12 水平尾翼的安装
Horizontal stabilizer installation

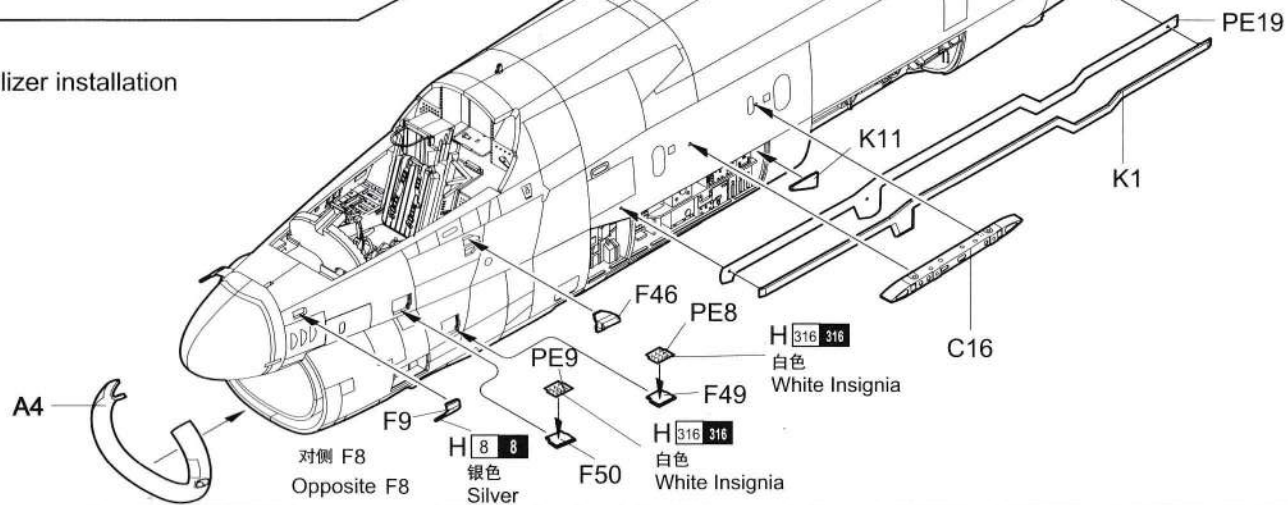

13 右侧机身
Right fuselage

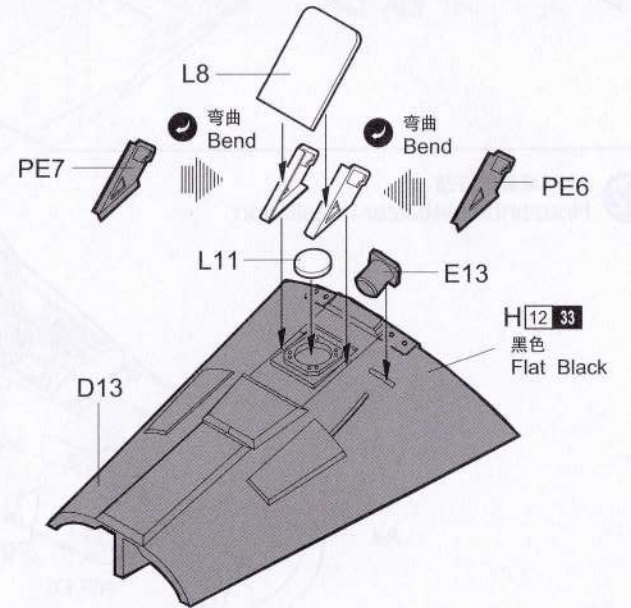
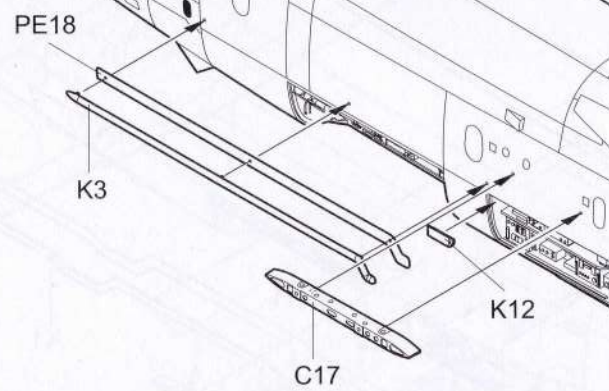
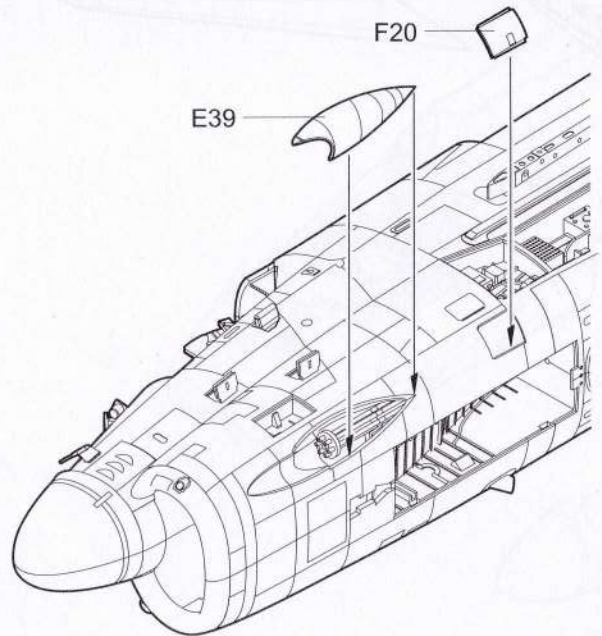
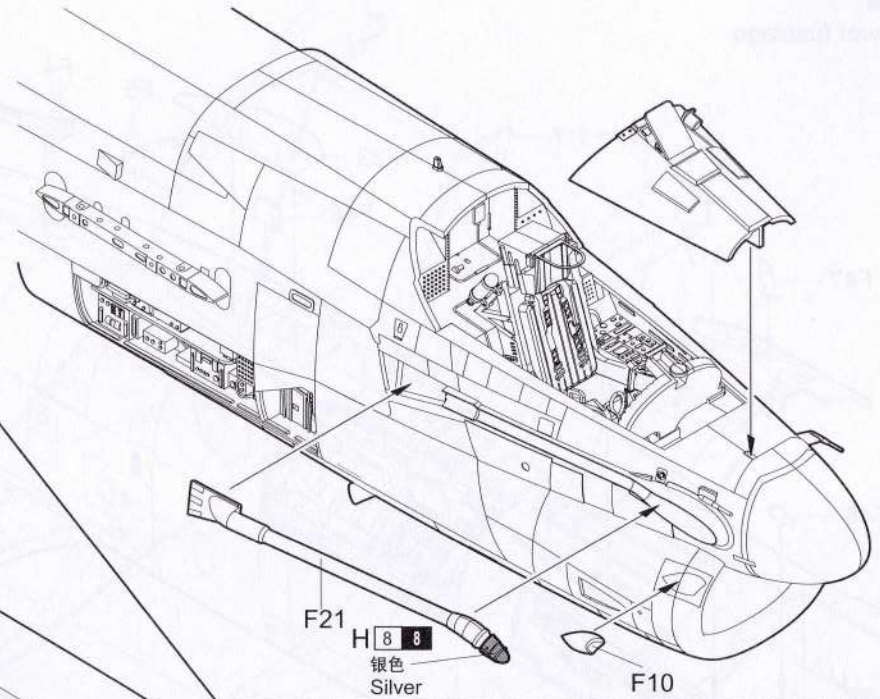
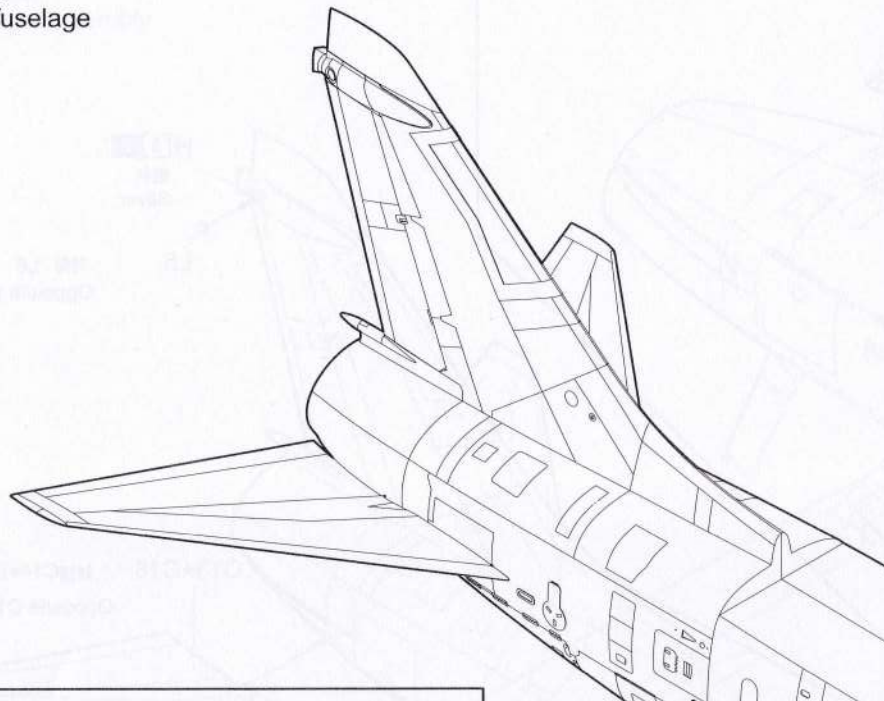

14 机翼的组装
Wing assembly

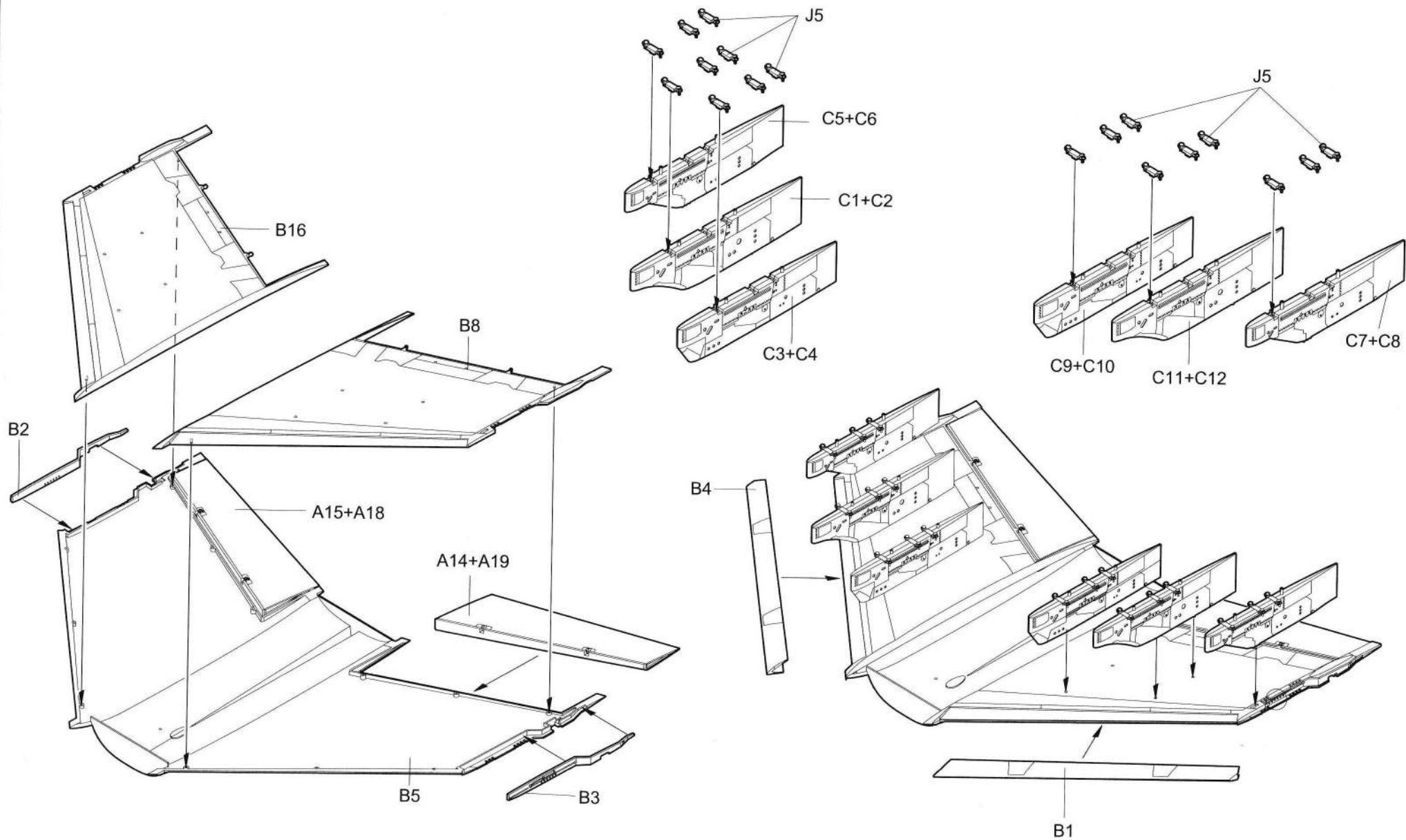

15

机翼的安装
Wing installation

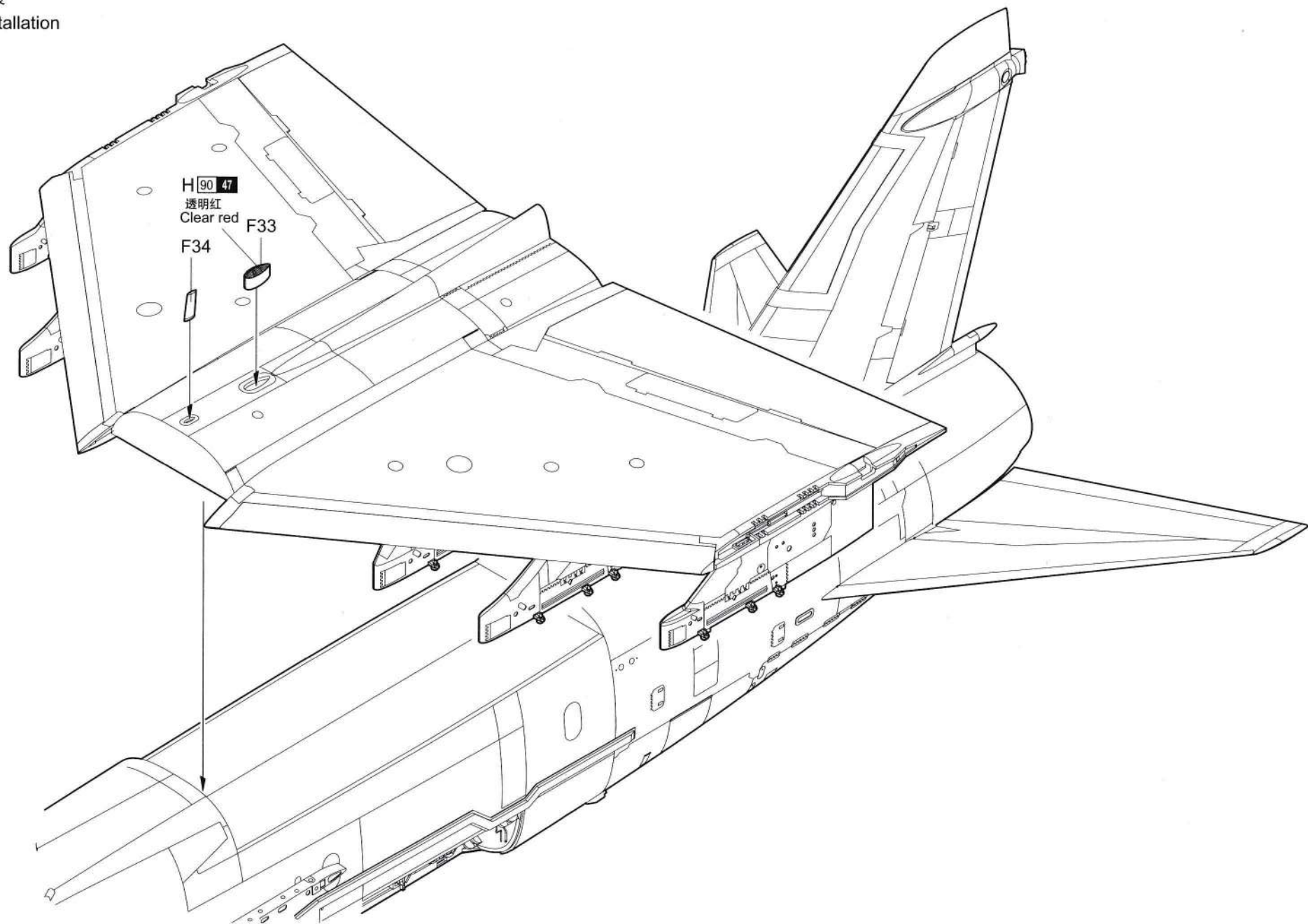

1

1

16 左侧主起落架的组装
Left main undercarriage assembly

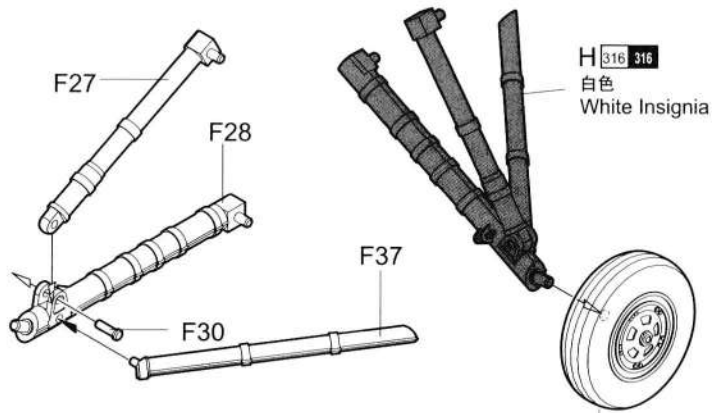

主轮的组装
Main gear assembly

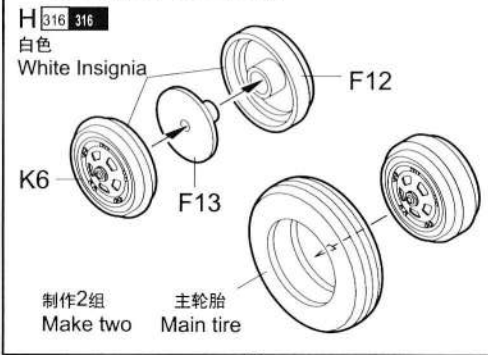

17 右侧主起落架的组装
Right main undercarriage assembly

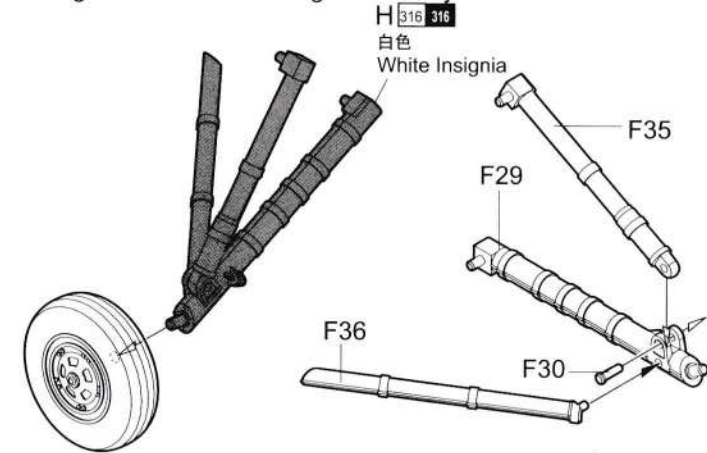

18 前起落架的组装
Nose undercarriage assembly

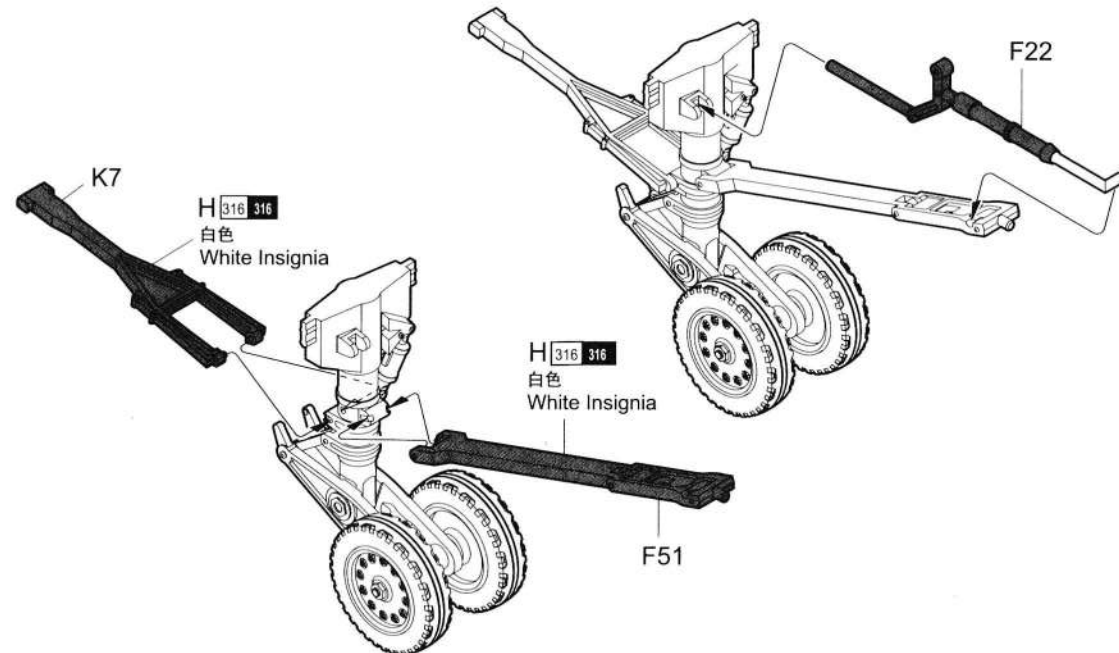
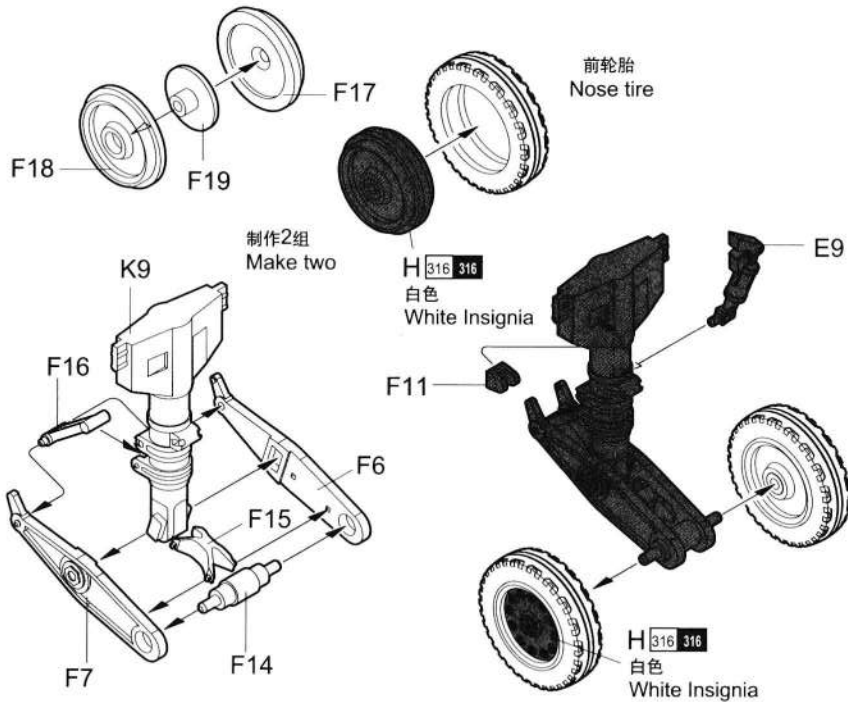

19 起落架的组装
Undercarriages installation

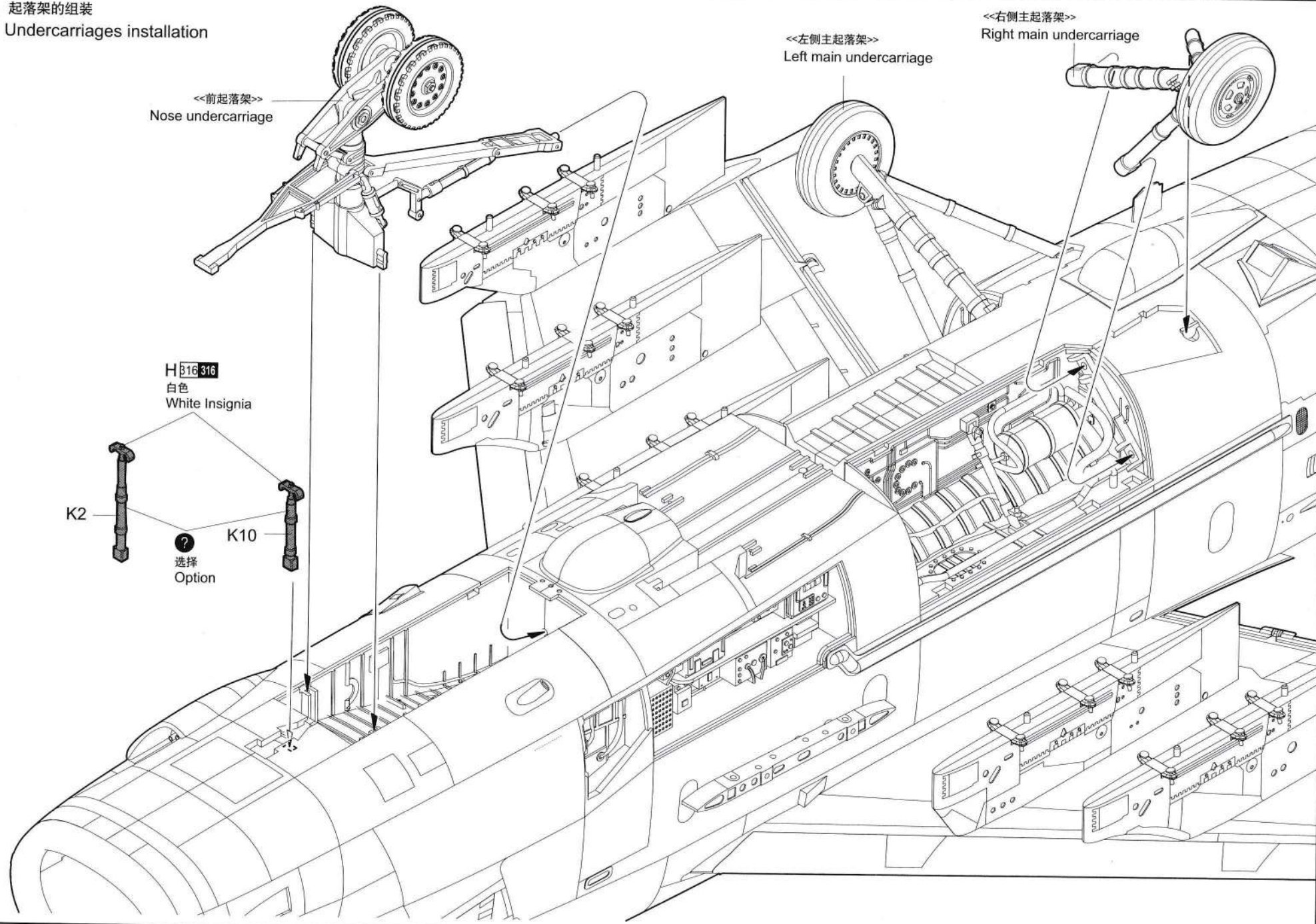

20 减速板的安装
Air brake installation

减速板打开状态
Open

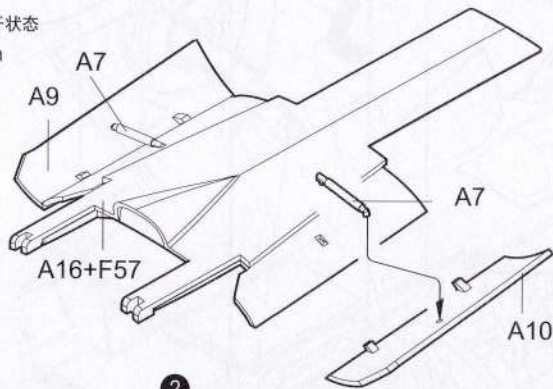

选择
Option

减速板关闭状态
Close

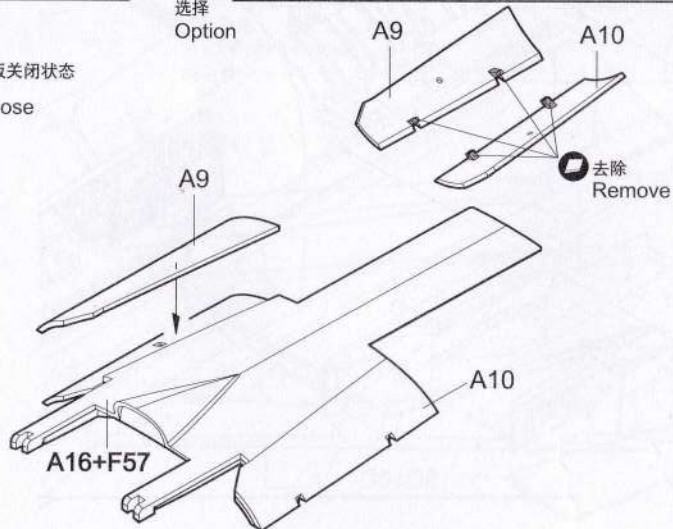

选择
Option

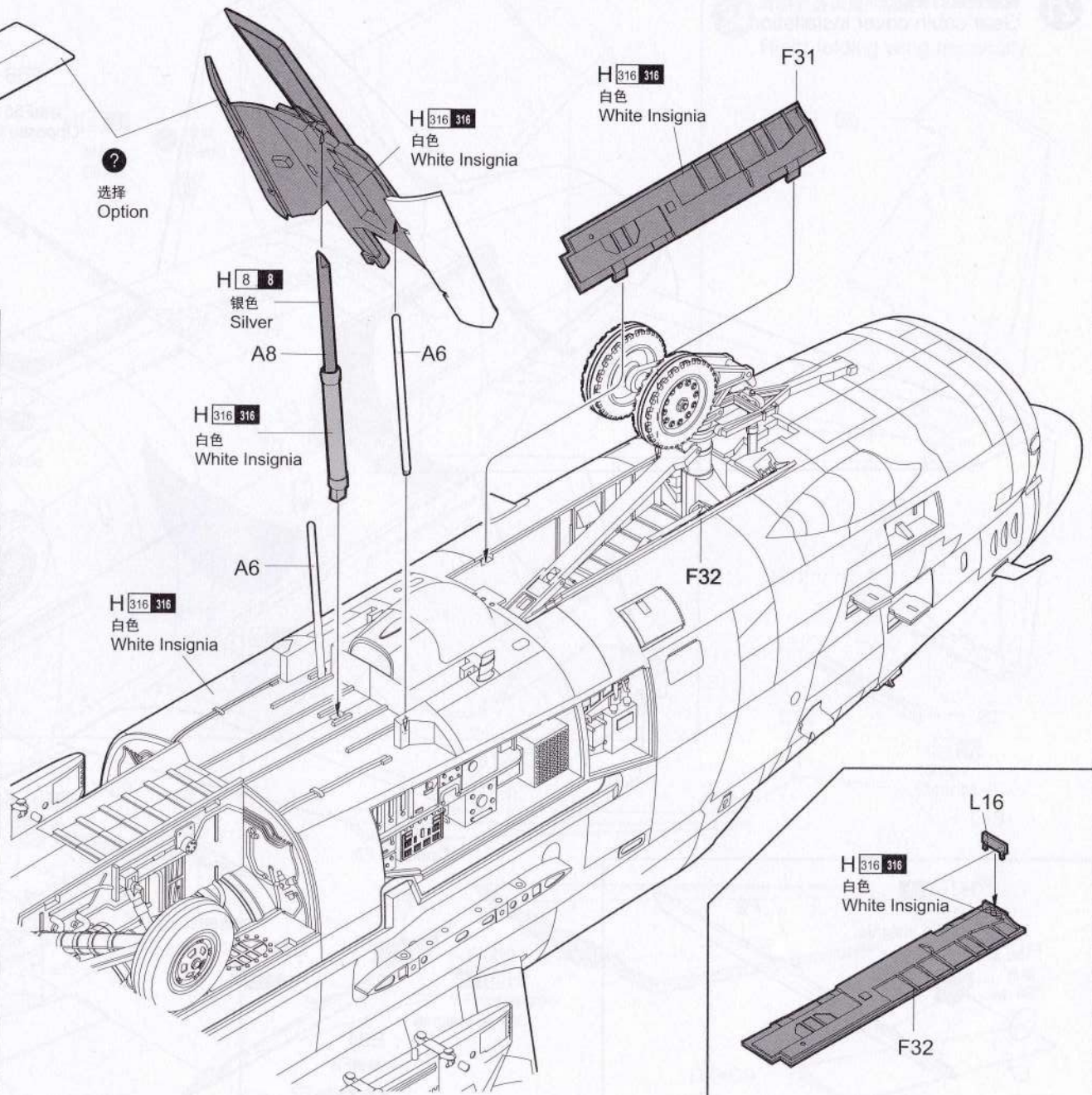

21 轮舱盖板的安装
Gear cabin cover installation

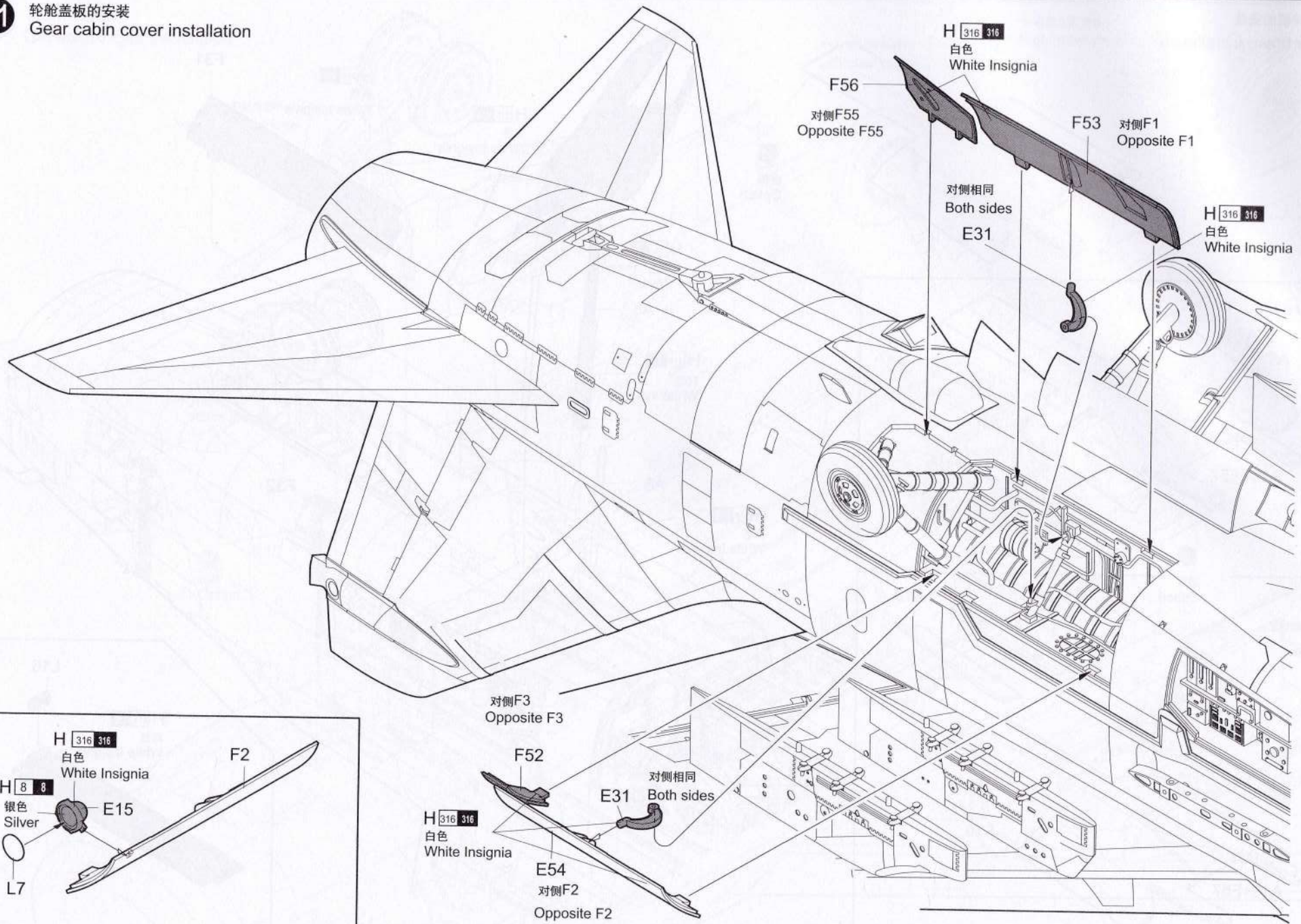

22 左侧折叠机翼的组装
Left folding wing assembly

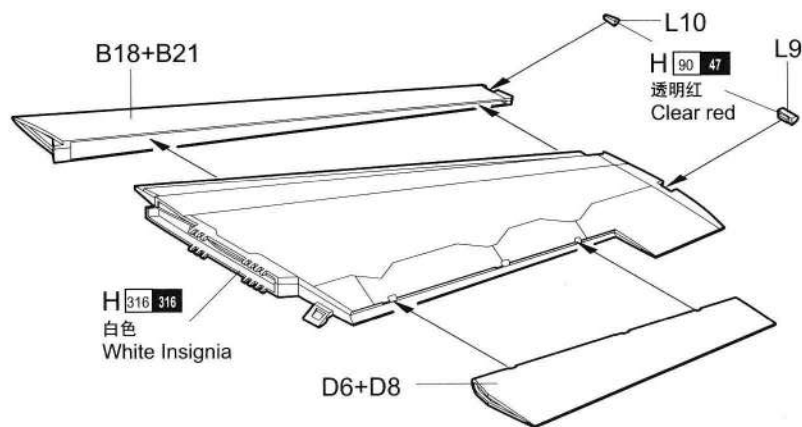
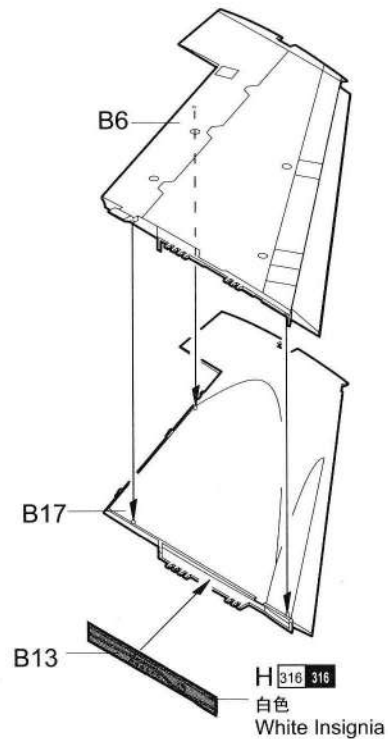

23 座舱罩的组装
Canopy assembly

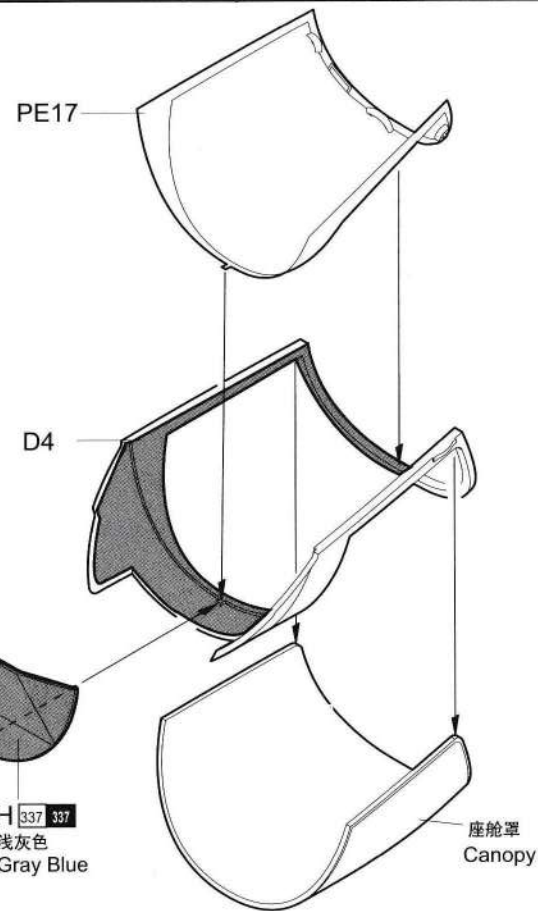
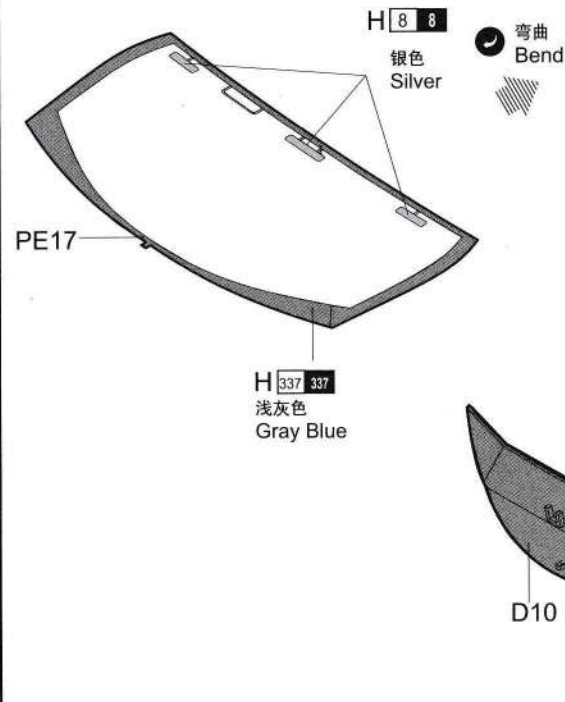

24 右侧折叠机翼的组装
Right folding wing assembly

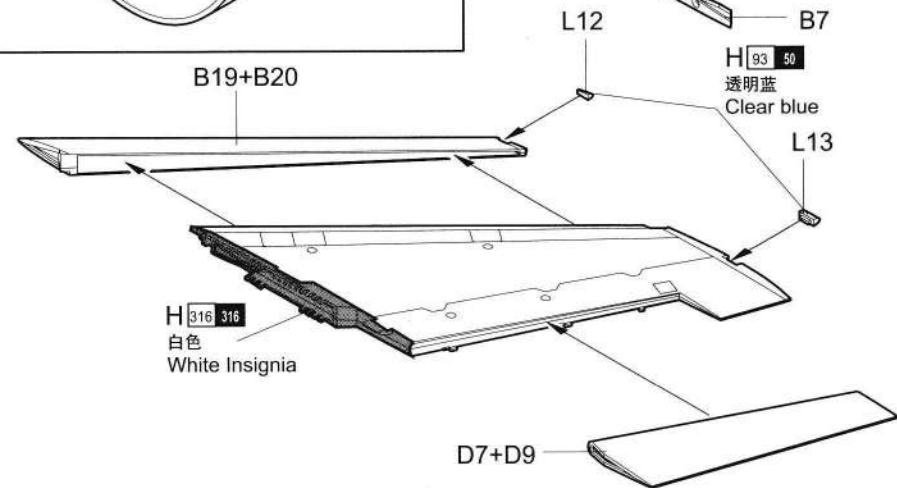
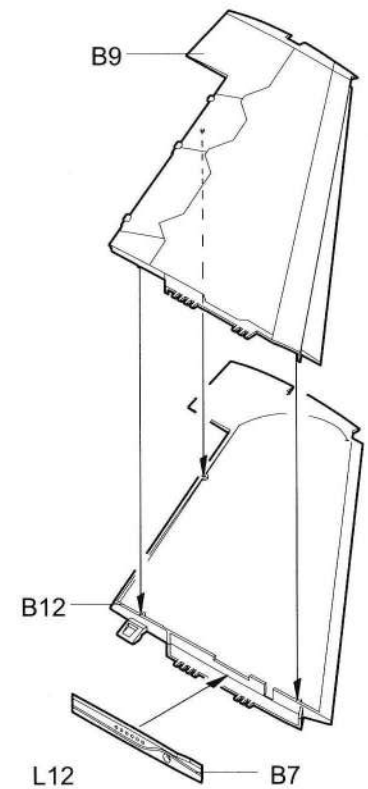

25 座舱罩的安装
Canopy installation

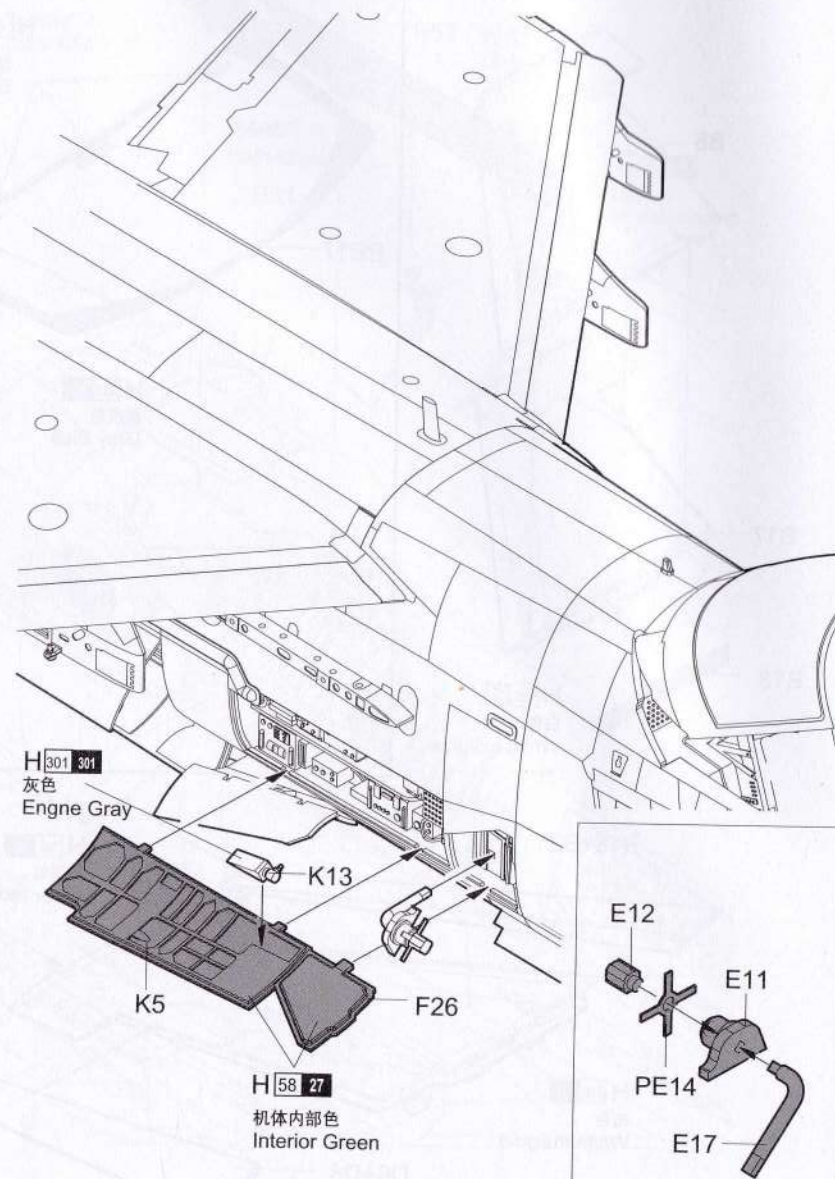
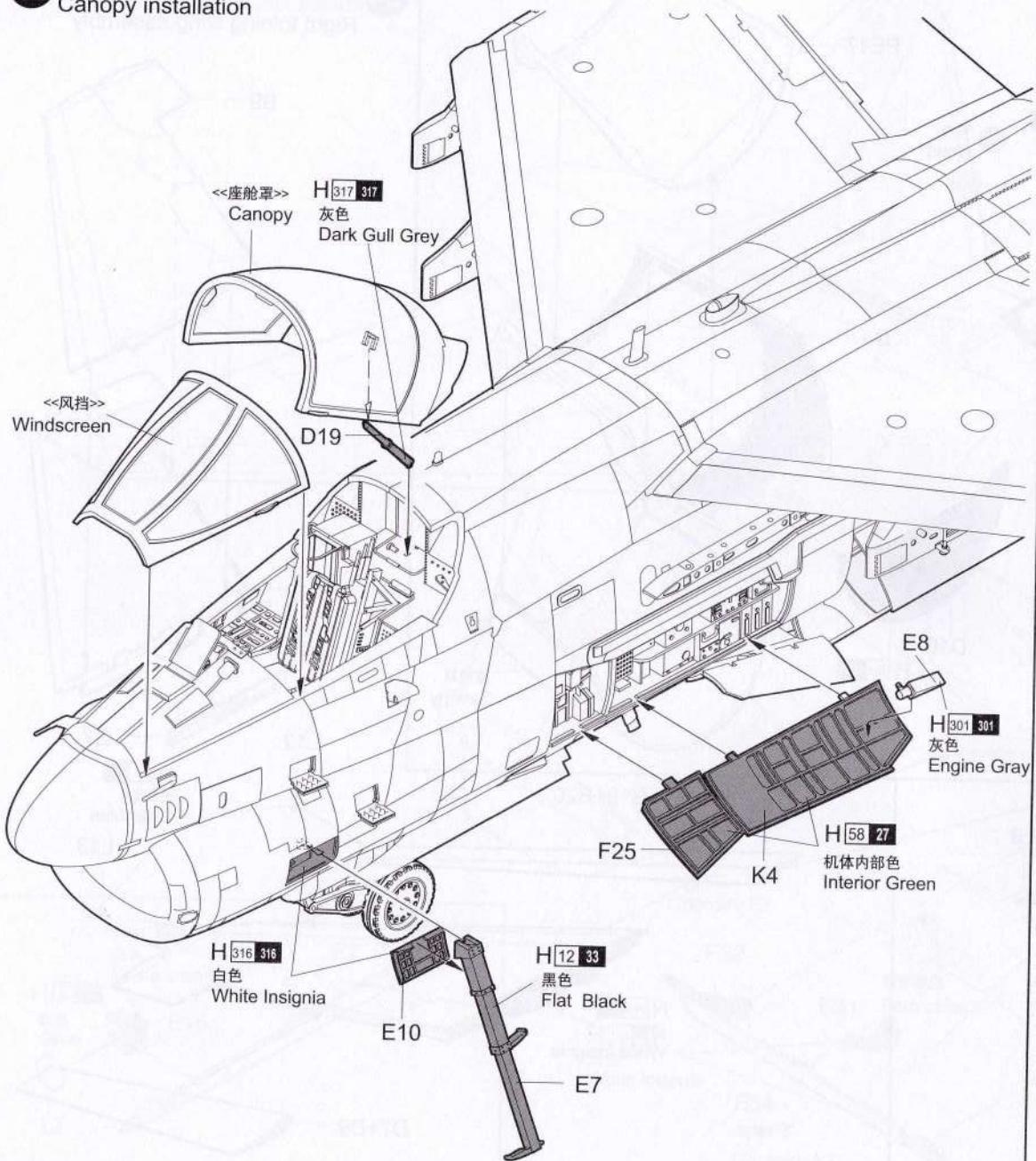

26 机翼的安装-折叠
Wing installation-folding

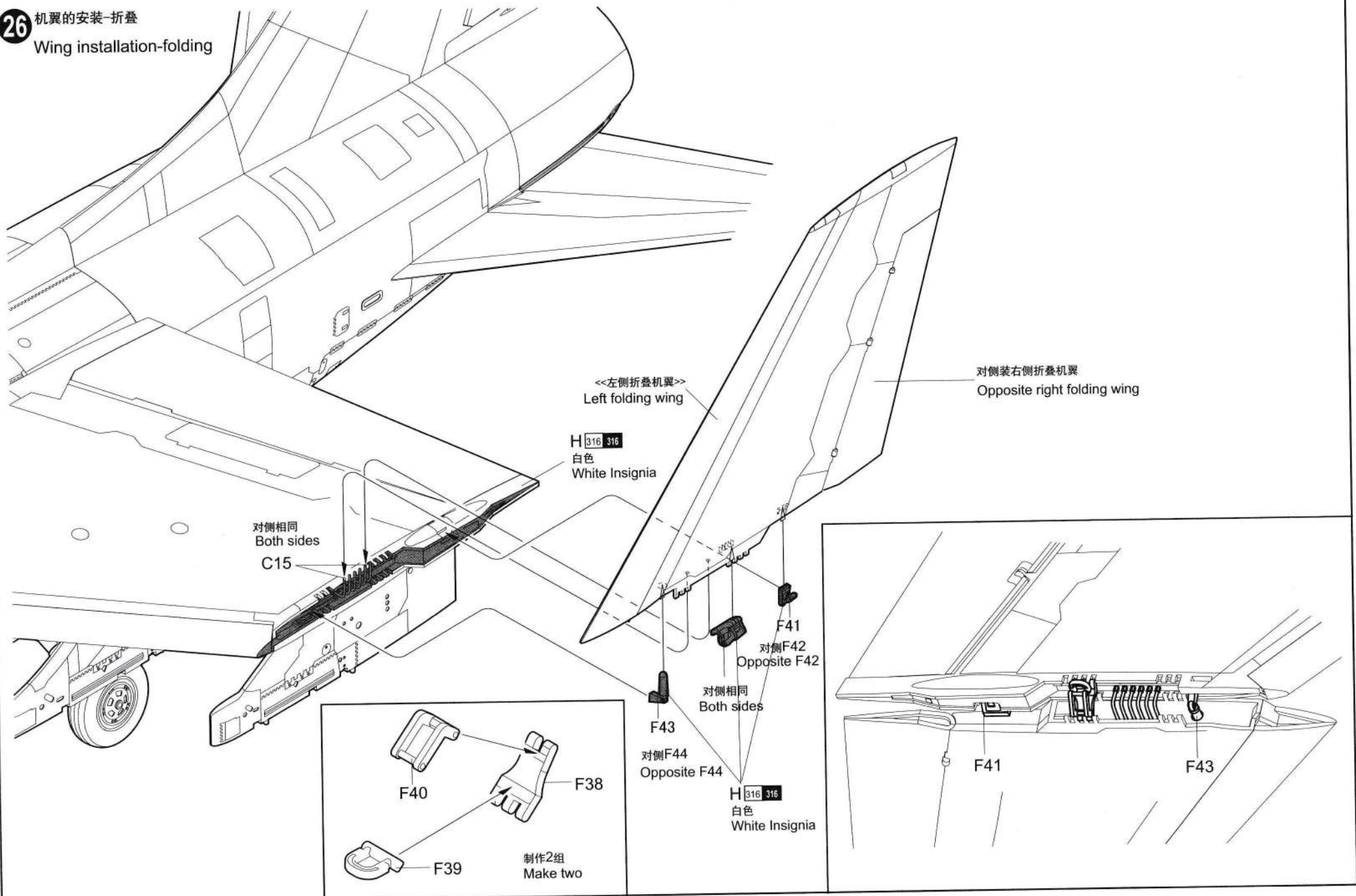

AGM12

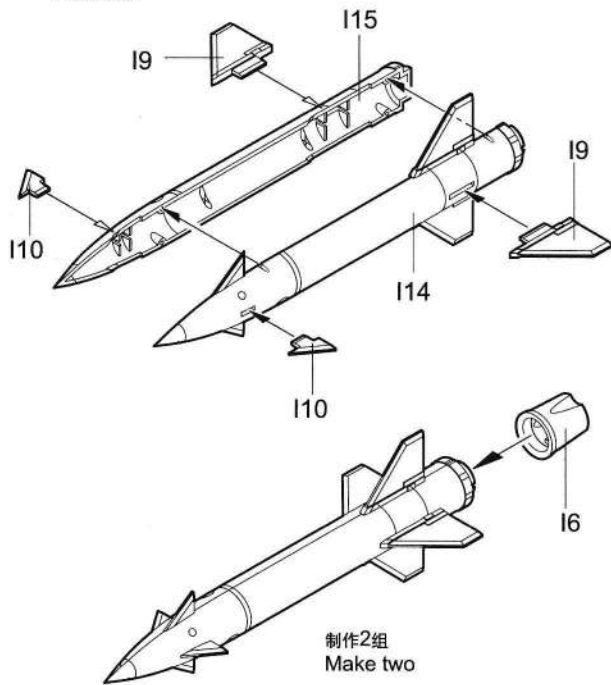

AGM45

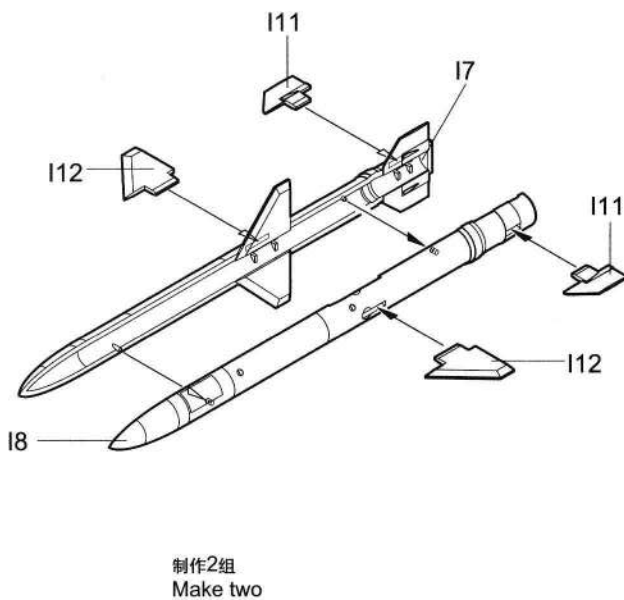

AIM9B

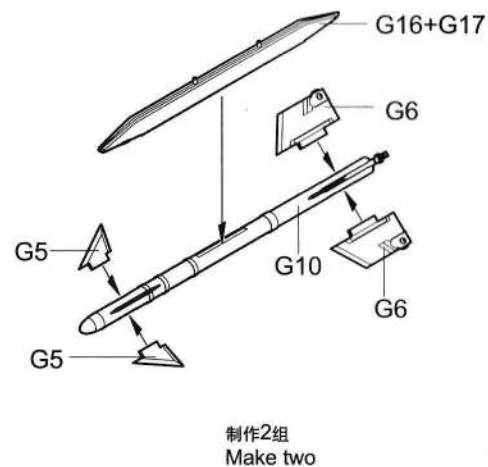

AGM65

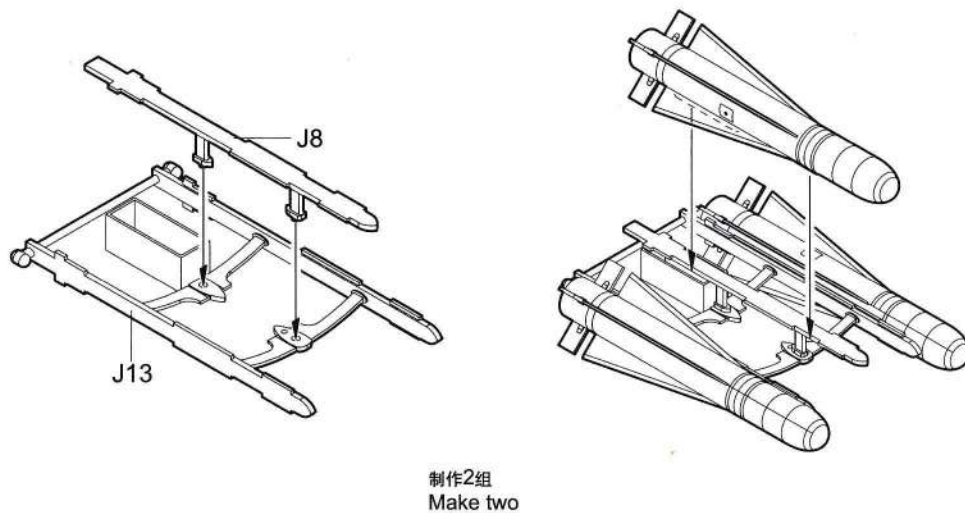
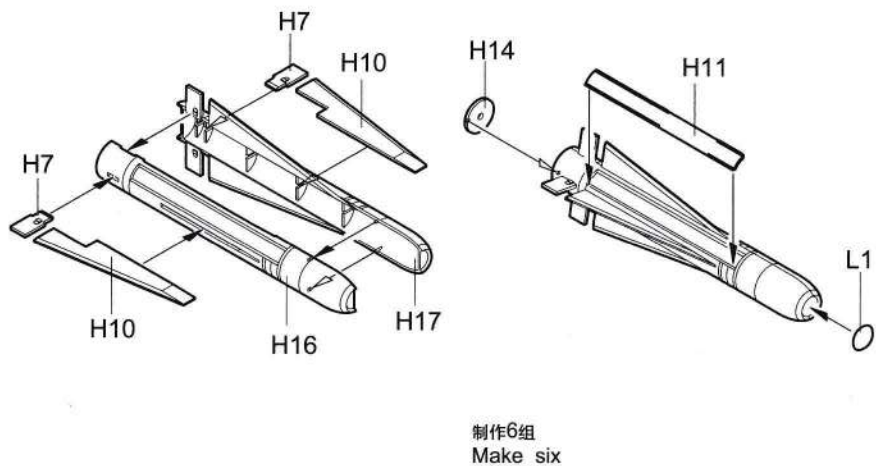

MK82

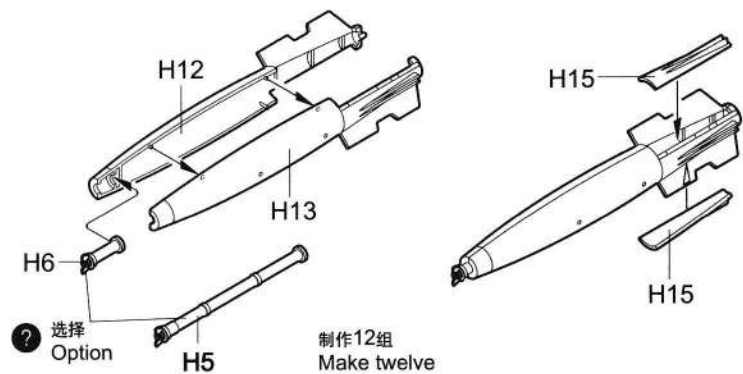
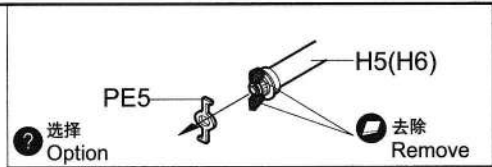

MK82

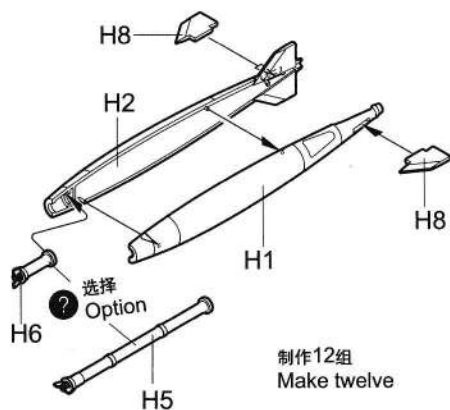

M117

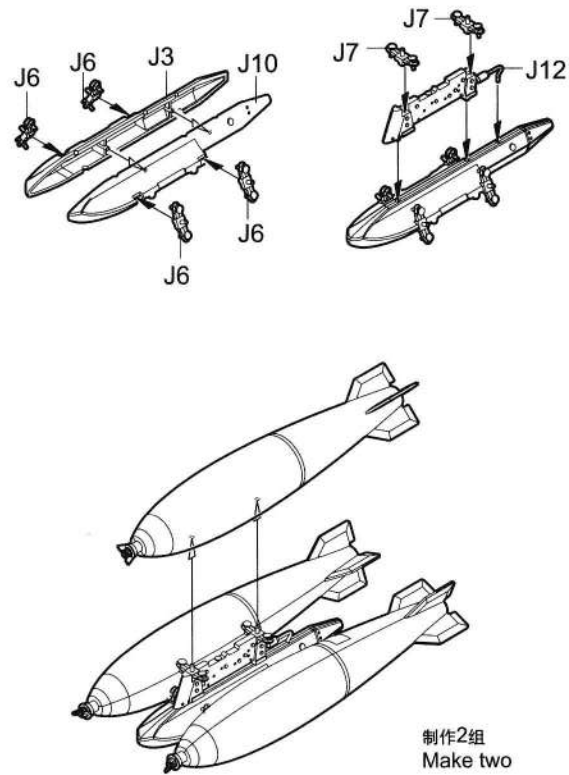
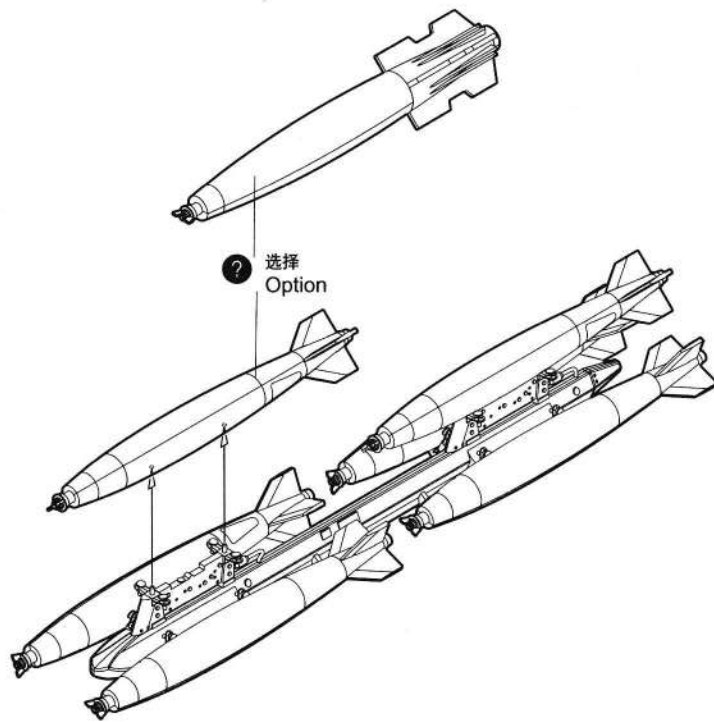
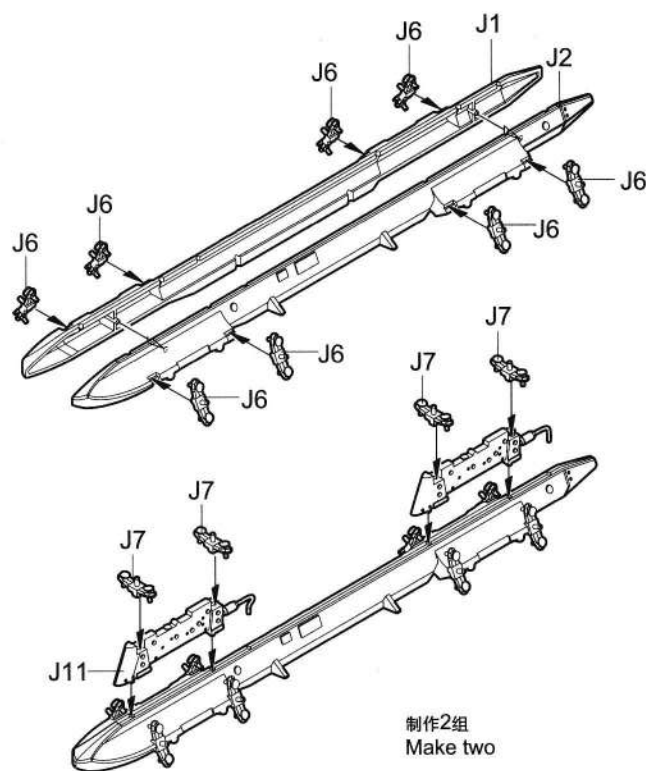
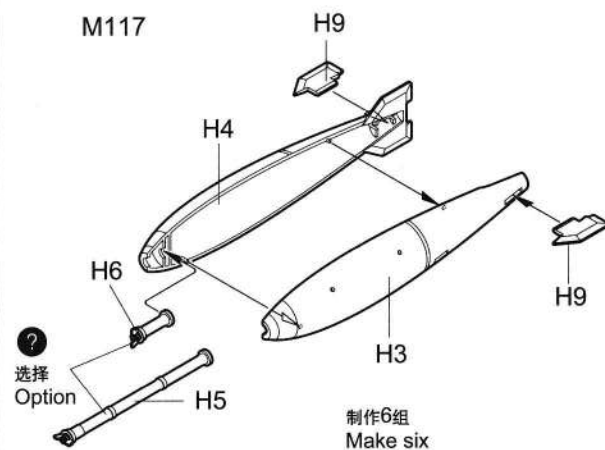

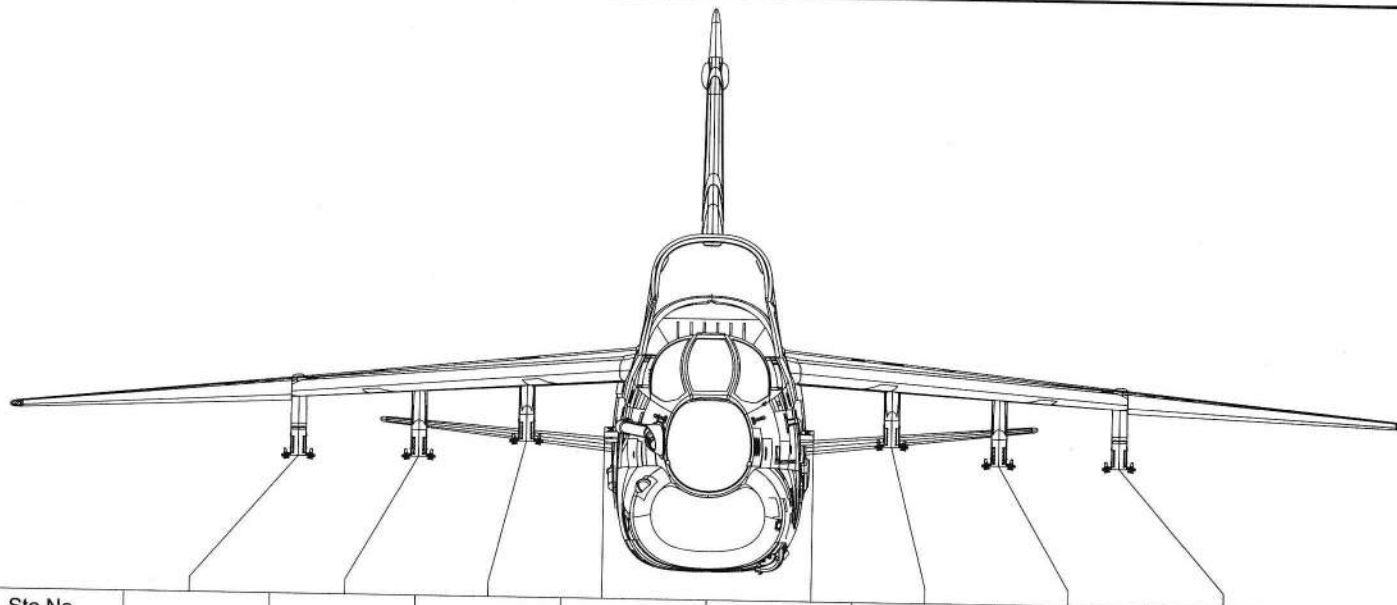

Sta.No.	1	2	3	4	5	6	7	8
Missile/Tank								
FUEL TANK	•		•			•		•
MK82	•••••	•••••					•••••	•••••
M117	•••	•••					•••	•••
AGM45	•	•					•	•
AGM12	•	•					•	•
AGM62A	•	•					•	•
AGM65		•••					•••	
FLIR						•		
AIM9B				•	•			
GBU-8		•					•	
GBU-10		•					•	

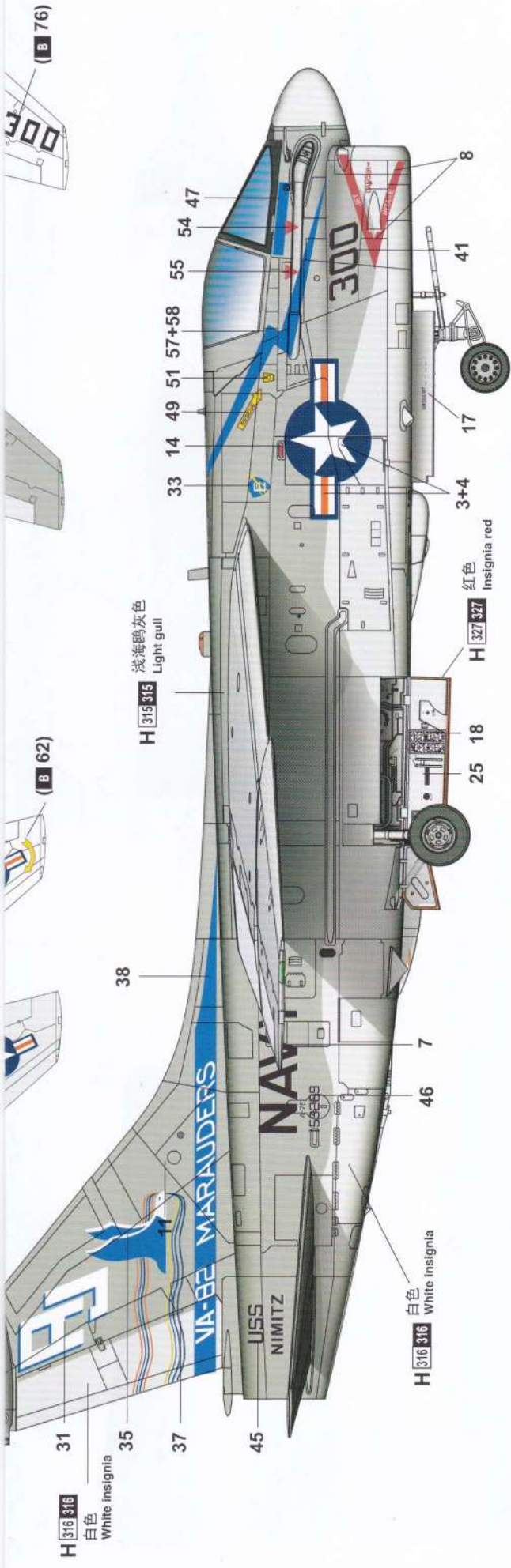

B

VA-192 CVW-11, USS Kitty Hawk 1972

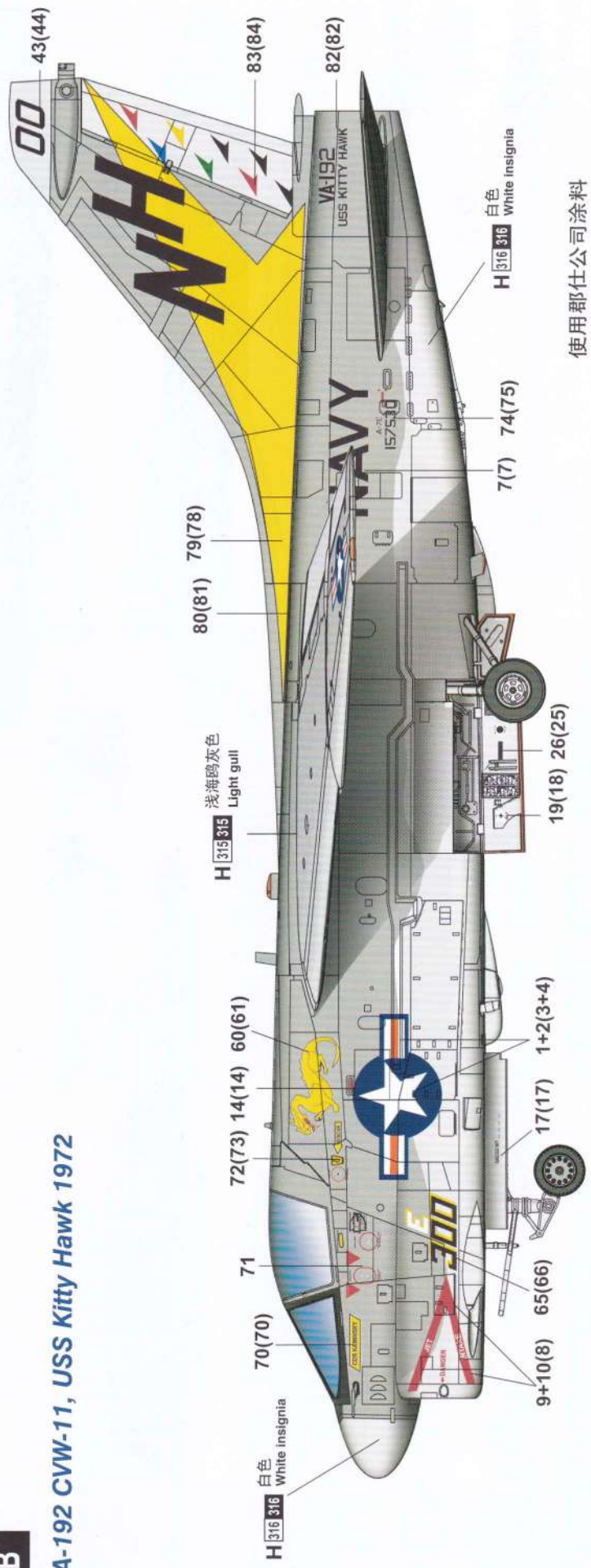

H 8 GUNZE SANGYO AQUEOUS HOBBY COLOUR

8 GUNZE SANGYO MR. COLOUR

使用郡仕公司塗料

GUNZE SANGYO Mr. Color used

涂装同标贴指示 Painting & Marking guide

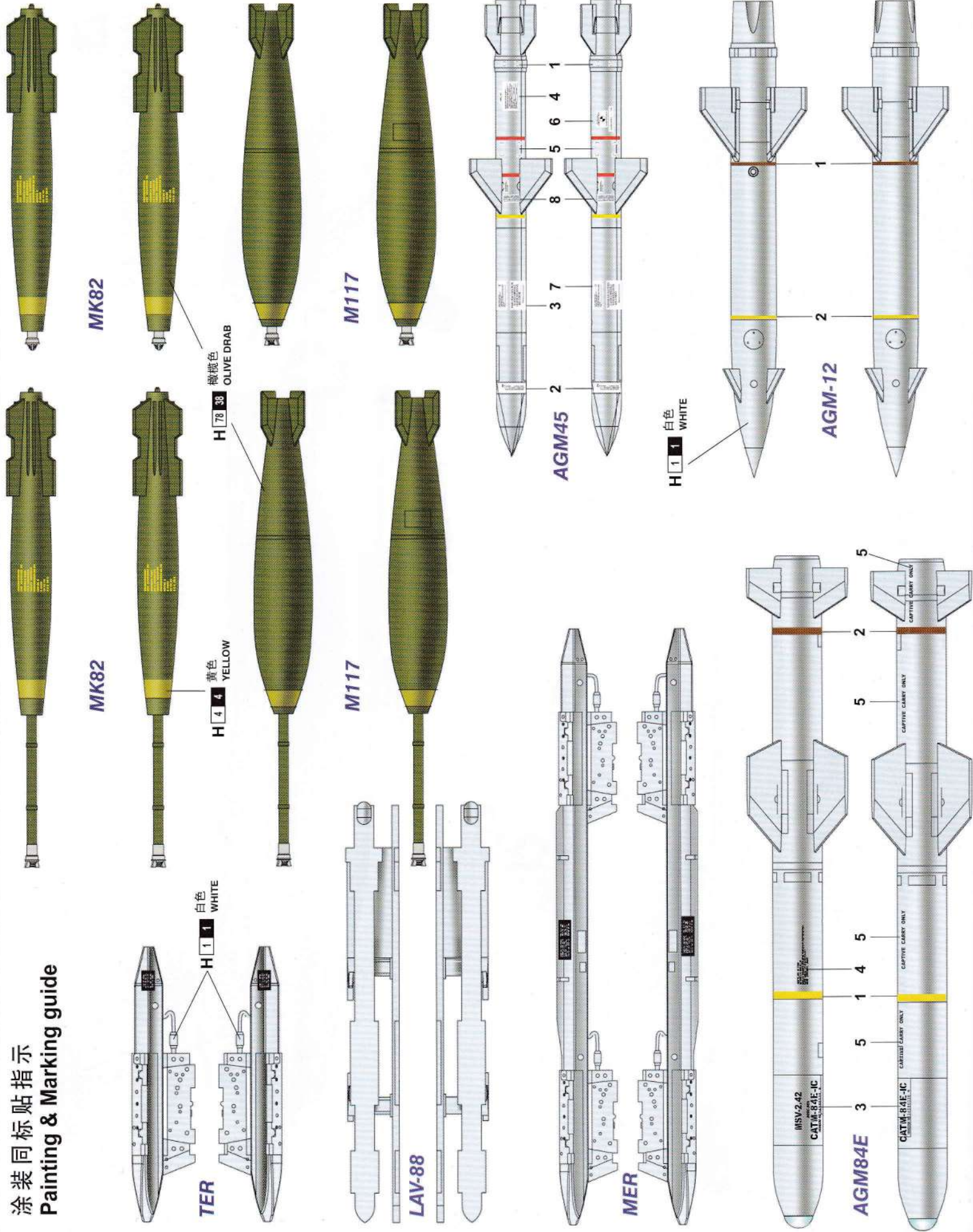

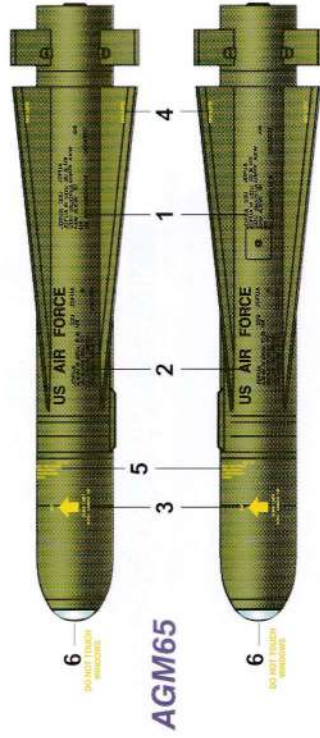

AGM65

H 78 38 橄榄色 OLIVE DRAB



GBU-10

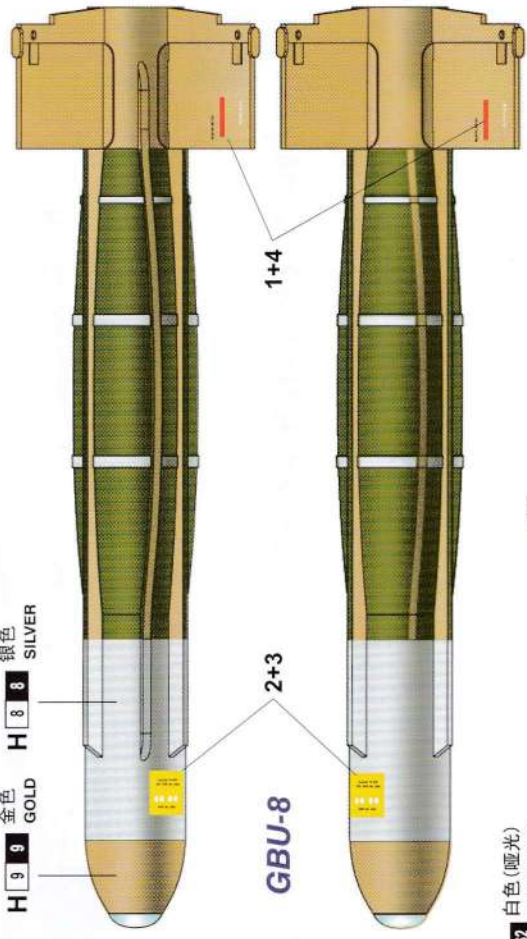

GBU-8

H 9 9 金色 GOLD
H 8 8 银色 SILVER

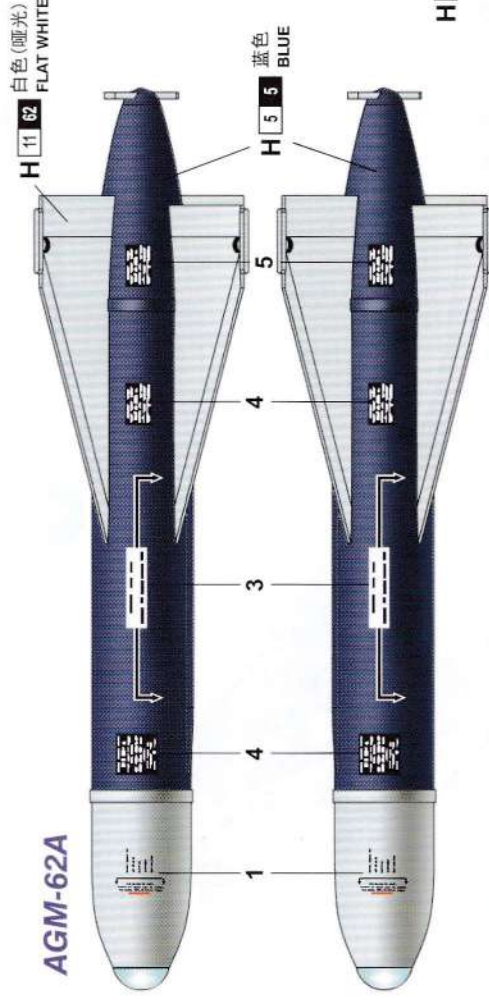

AGM-62A

H 11 62 白色(哑光) FLAT WHITE
H 5 5 蓝色 BLUE

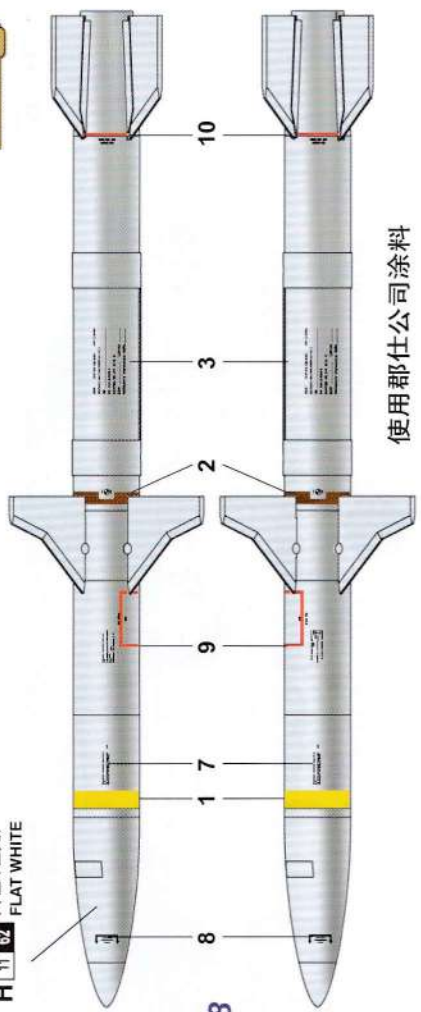

AGM88

H 11 62 白色(哑光) FLAT WHITE
H 18 28 黑色(哑光) FLAT BLACK
H 12 33 黑色(哑光) FLAT BLACK
H 4 4 黄色 YELLOW
H 18 28 黑铁色 METAL BLACK

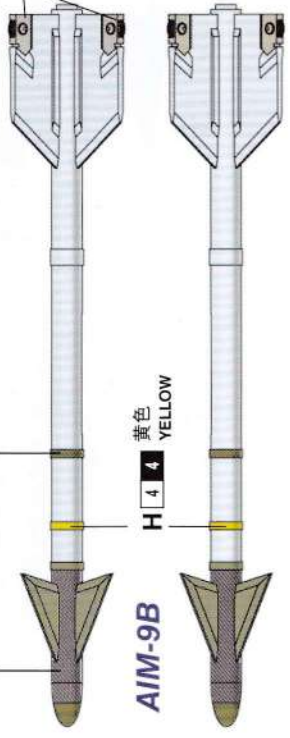

AIM-9B

使用郡仕公司涂料

GUNZE SANGYO Mr. Color used

H 8 GUNZE SANGYO MR. COLOUR

H 8 GUNZE SANGYO AQUEOUS HOBBY COLOUR