

CH-47A “CHINOOK”

CH-47A “支努干”

READ BEFORE ASSEMBLY

- Study and understand these instructions thoroughly before beginning assembly. Make sure all parts are included by comparing them to those shown on pages 2 & 3 of these instructions.
- Remove parts from sprues as needed, and trim excess with a hobby knife. Be careful not to lose small parts.
- Remove photo-etch parts from sprue as needed using a hobby knife or photo etch cutter.
- Apply cement to photo etch parts as shown on instructions. Applying too much cement will restrict the operation of these

水贴纸的使用:

1. 从水贴纸上剪下印花;
2. 将印花放入温水中浸10秒, 然后放在干净布上。
3. 拿着印花纸板将印花移到模型上;
4. 手指蘸水将印花移到适当的位置;
5. 用软布轻压印花直至水干, 汽泡消失。

DECAL APPLICATION

1. Cut off decal from sheet.
2. Dip the decal in tepid water 40°C for about 10 sec. and place on a clean cloth.
3. Hold the backing sheet edge and slide decal onto the model.
4. Move decal into position by wetting decal with finger.
5. Press decal gently down with a soft cloth until excess water and air bubbles are gone.

movable parts. Apply cement carefully! Removed photo etch parts can have sharp edges. Take care when handling these to avoid injury.

- Apply decals to necessary parts prior to assembly.
- Additional tools recommended(not included):Sprue cutter, Long nose pliers, hobby knife, file, tweezers, pin vise, scissors, cement, sandpaper, soft cloth, glue and paint.
- Keep all parts out of reach of children, as they pose a choking hazard. Discard all unnecessary bags and sprues when model is completed to avoid accidental injury.

装配之前仔细阅读

- 小心用模型锉刀锉平所有零件表面的注射浇口。
- 小心用刀片切下蚀刻片零件, 不要遗失小零件。
- 用强力快干胶水粘合蚀刻片零件和金属轴。过量的快干胶水使用可能导致可动零件会粘住, 小心涂胶。
- 取蚀刻片时应特别注意安全, 防止利刃划伤手指。
- 某些零件表面需贴水上贴纸, 请选择在装配的同时进行。推荐模型工具(自备): 胶水, 水口剪刀, 长嘴钳, 刀片, 镊子钳, 钻, 剪刀, 瞬间快干胶。
- 软布同砂纸同时也应该是必备工具。
- 请使用塑料胶水和油漆, 模型内不含。
- 谨防小孩吸吮塑料零件, 或者将塑料袋套在头上, 制作时应将套材远离小孩接触。



Cyanoacrylate glue
使用强力胶



weight
配重



make hole
钻孔



cut / remove
切除



option
选择



no cement
不涂胶水



decal
贴纸



bend
弯曲



file / sand
锉平

部品图
Parts

《左机身》
Left fuselage x1

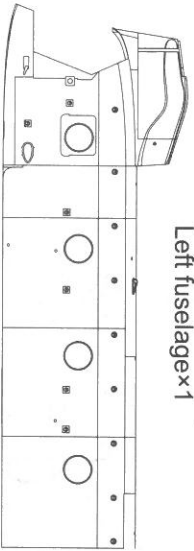

《右机身》
Right fuselage x1

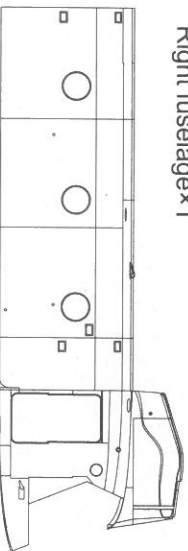

《右侧后机身》
Right tail fuselage x1

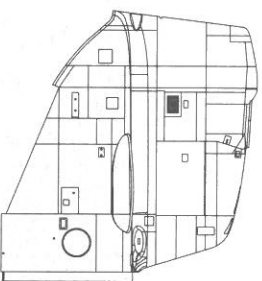

《左侧后机身》
Left tail fuselage x1

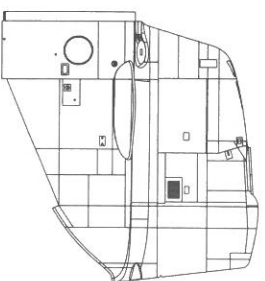

A x1

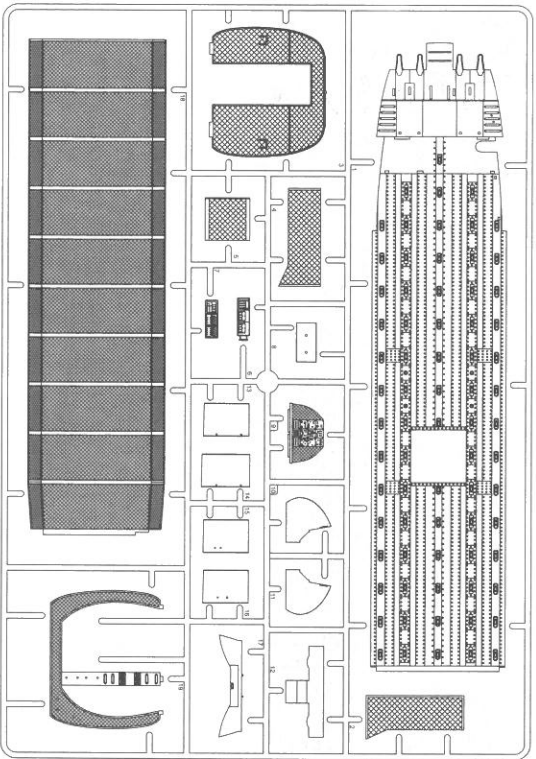

B x1

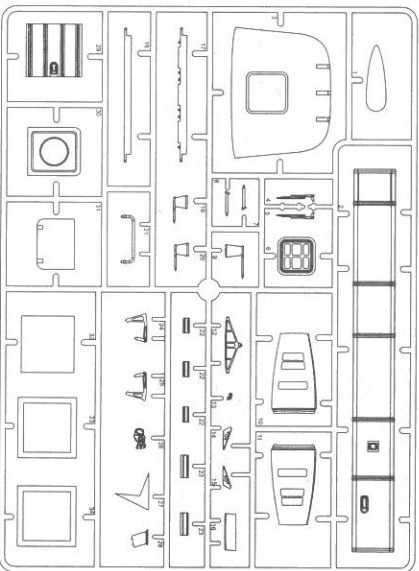

D x2

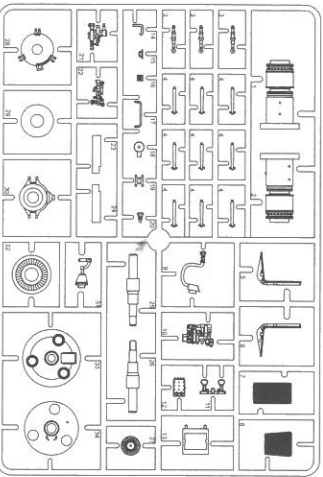

C x1

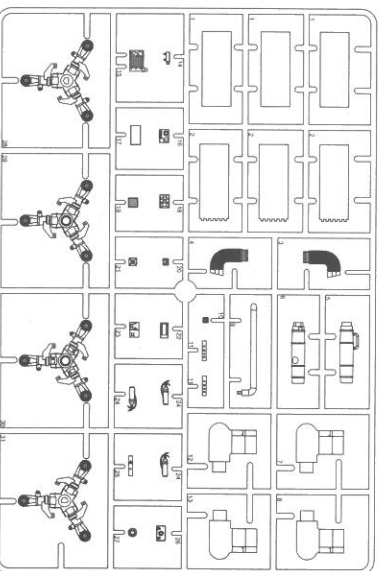

Hx1

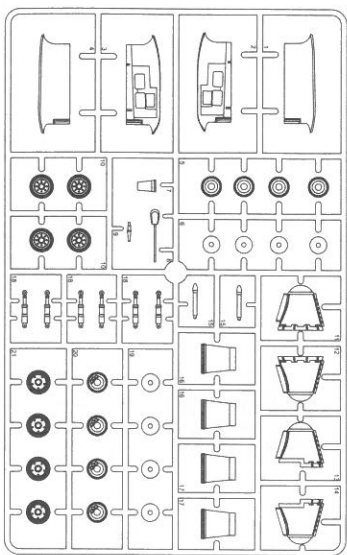

Jx1

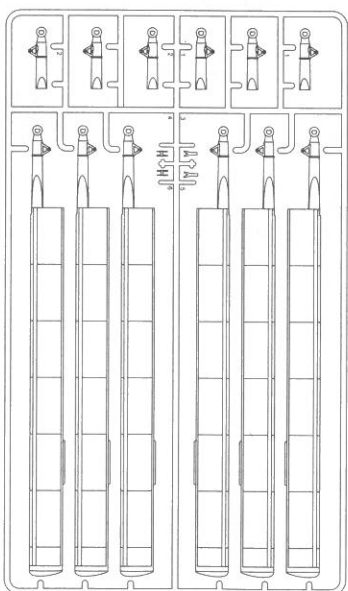

《金属部件》
Metal Parts(MP)

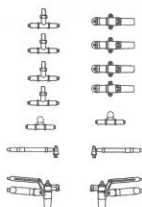

《前轮胎》
Fore tires



《后轮胎》
Rear tires



Gx1

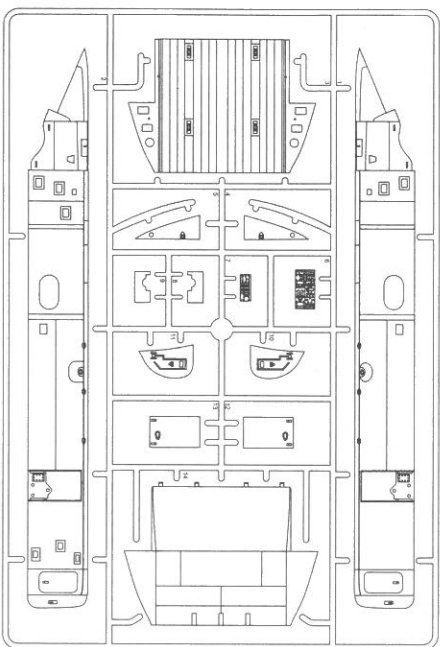

Lx1

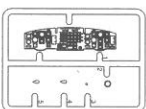

《座舱罩》
Canopy



《菲林片》
Film



《蚀刻片》
Photo Etched Parts(PE)

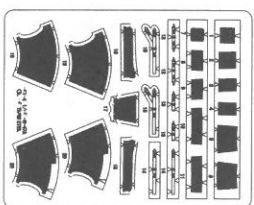

《水贴纸》
Decal

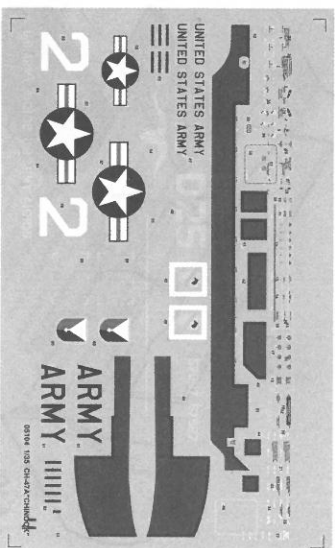

Kx1

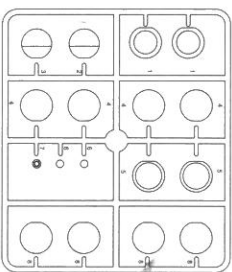

1

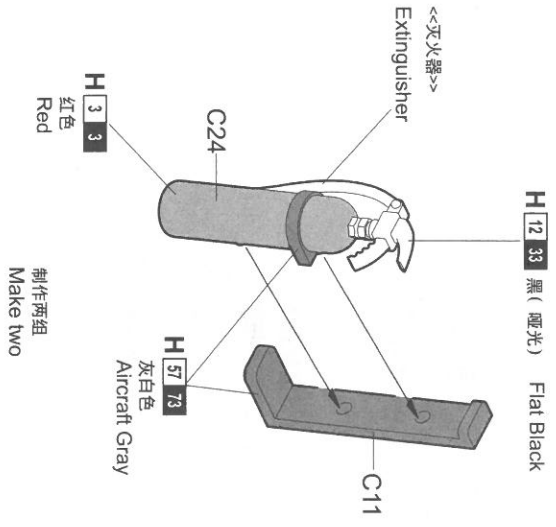

2

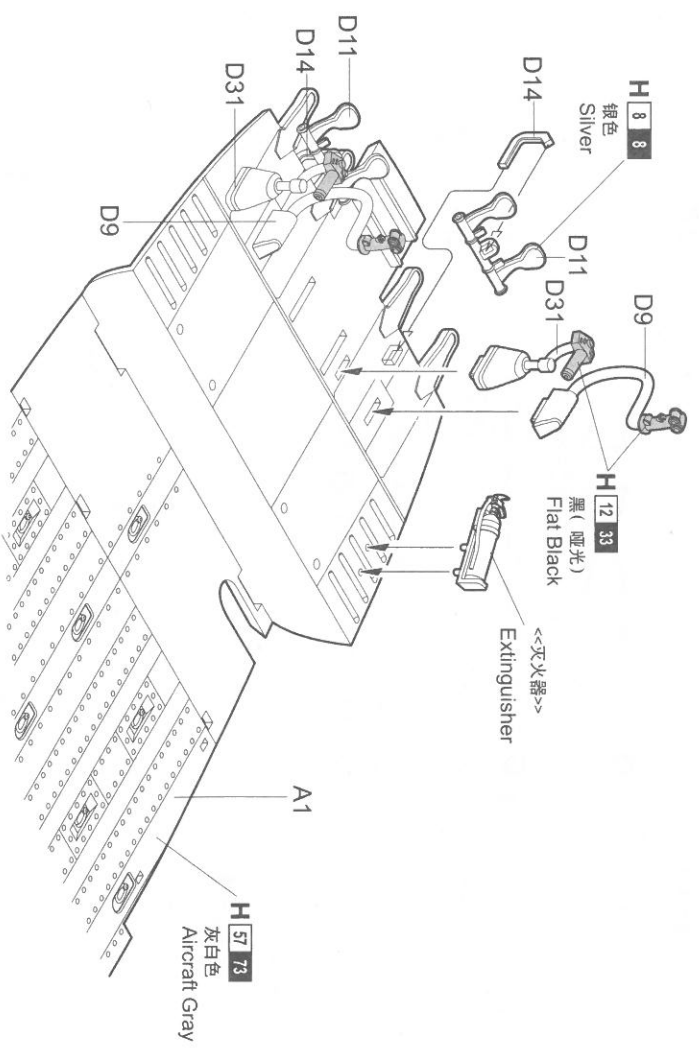

3

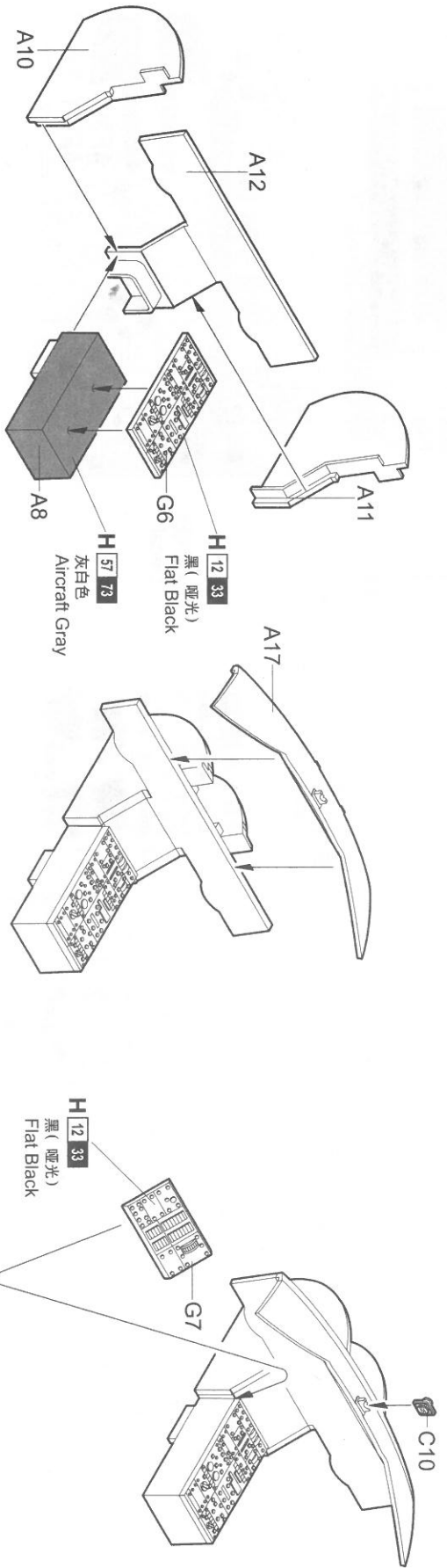

4

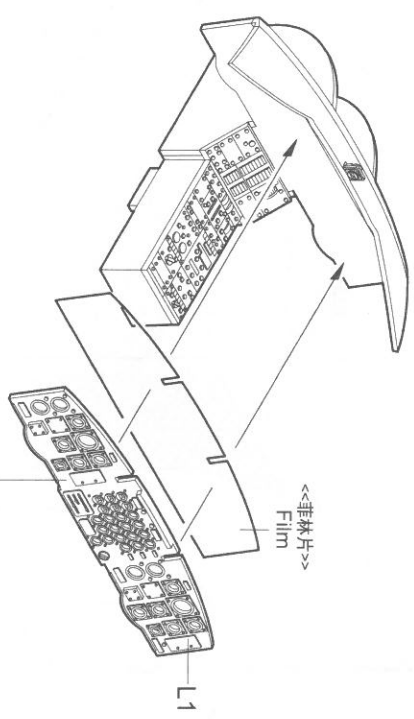

H 12 33
黑 (哑光)
Flat Black

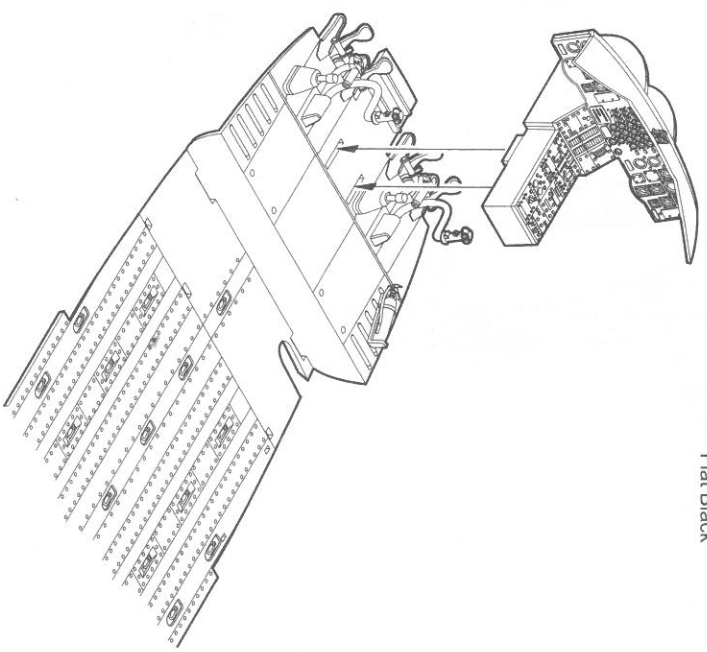

5

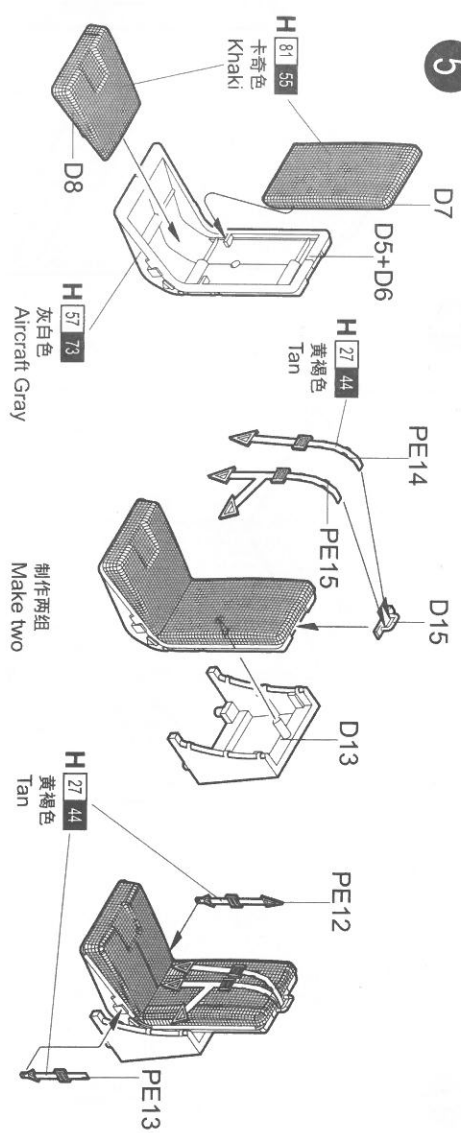

6

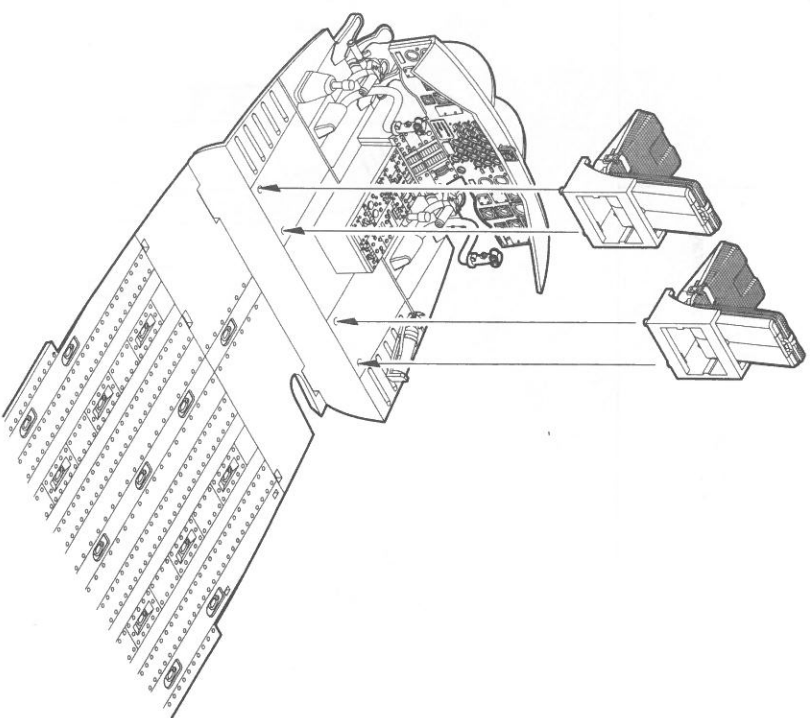

7

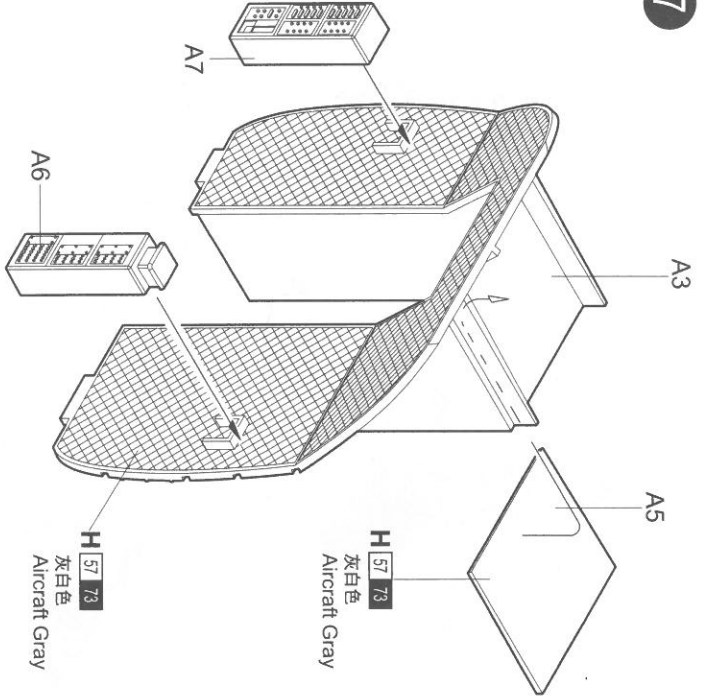

9

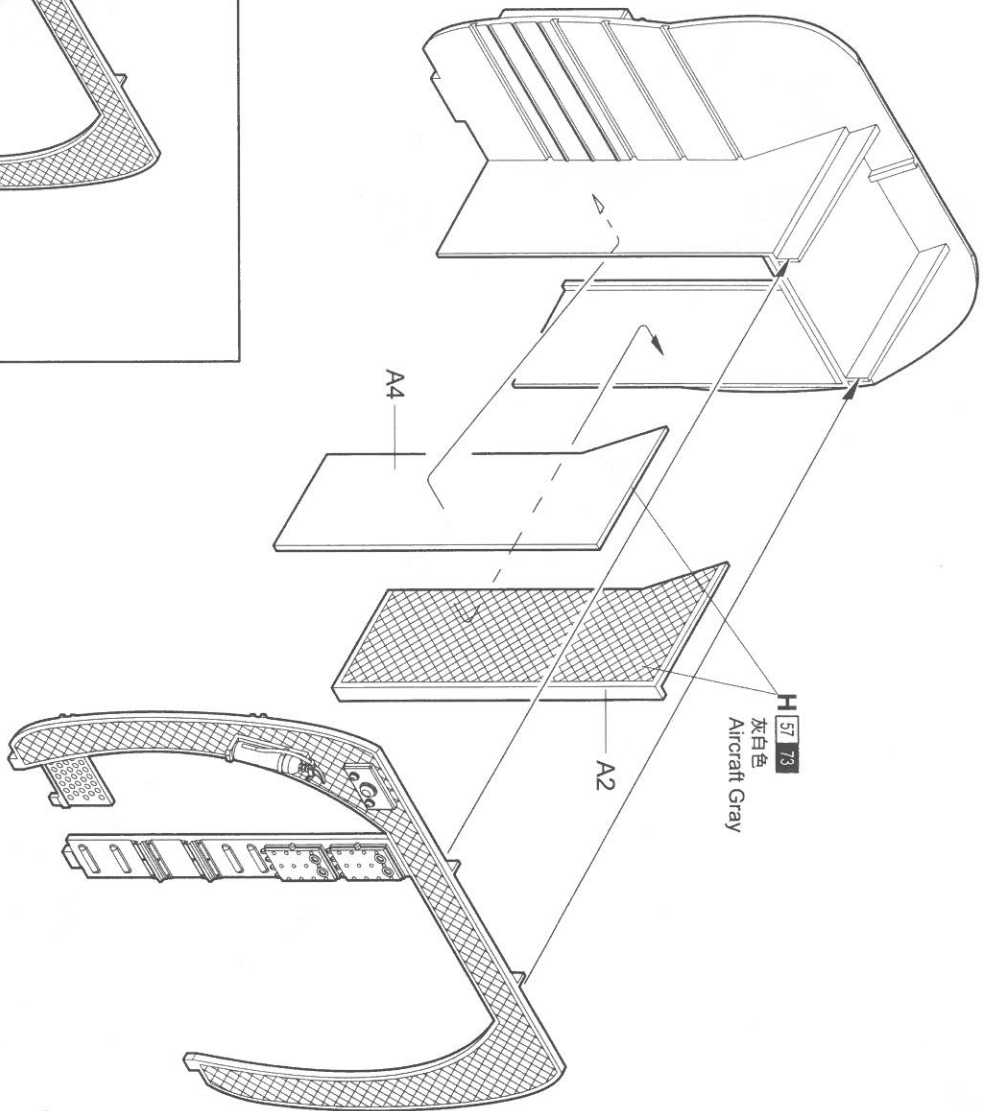

8

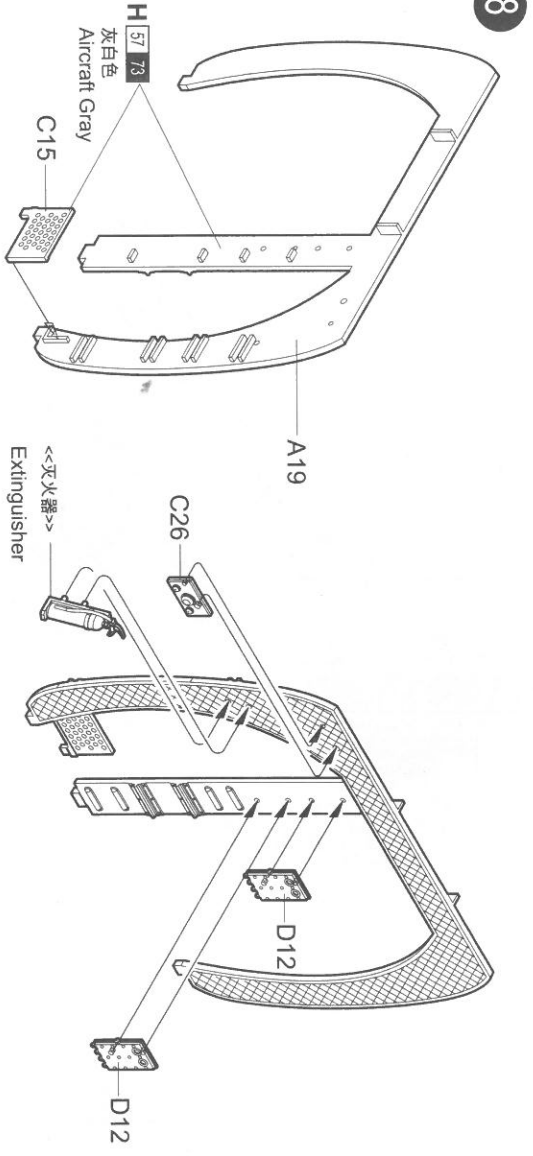

10

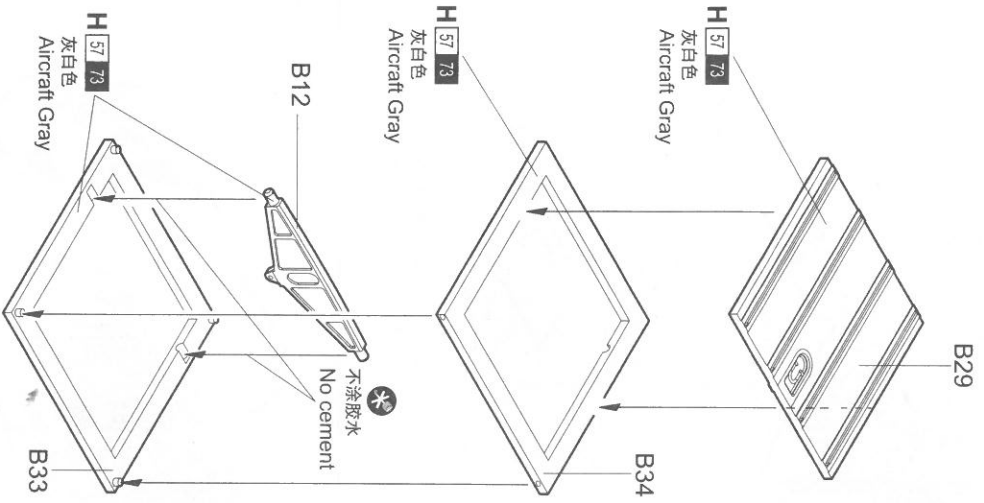

11

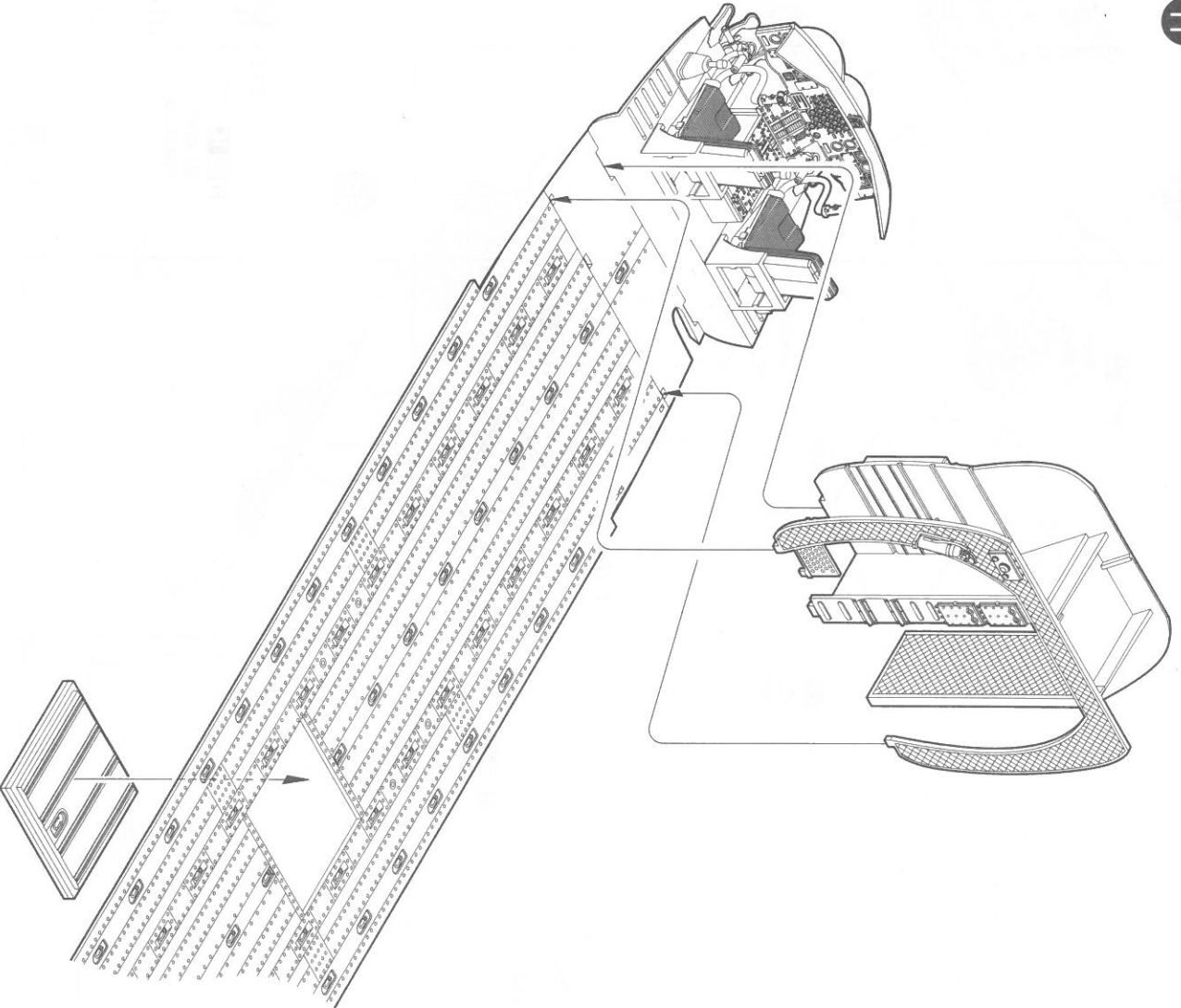

12

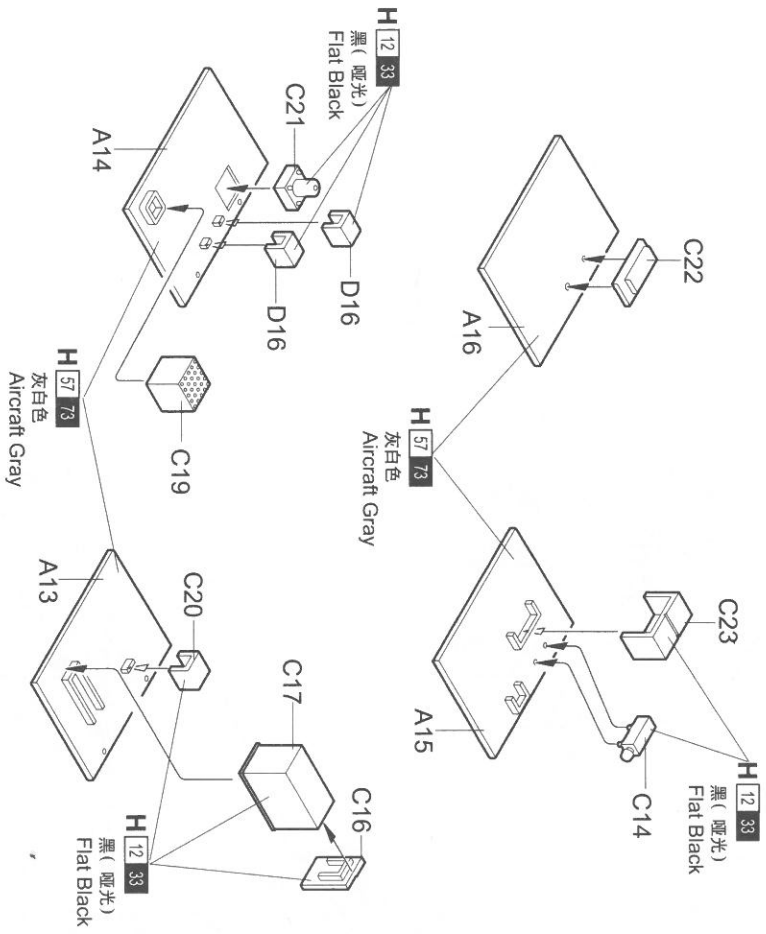

13

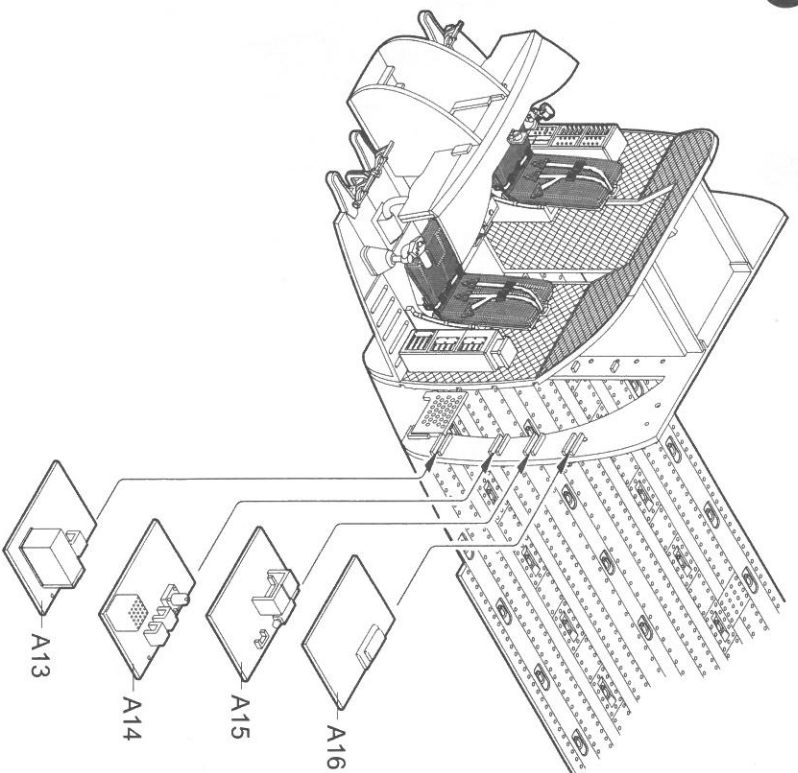

14

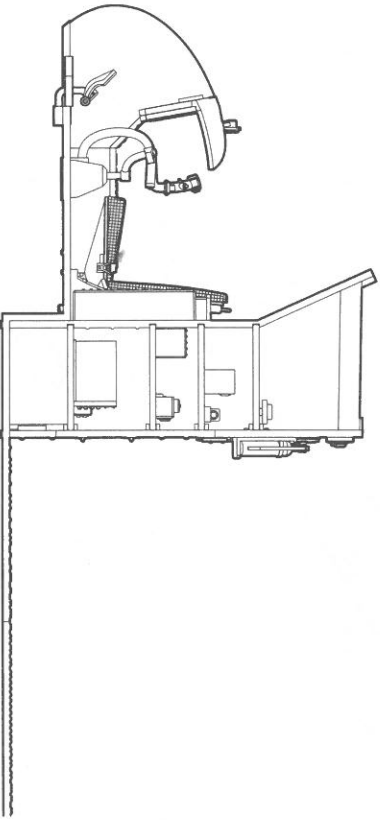
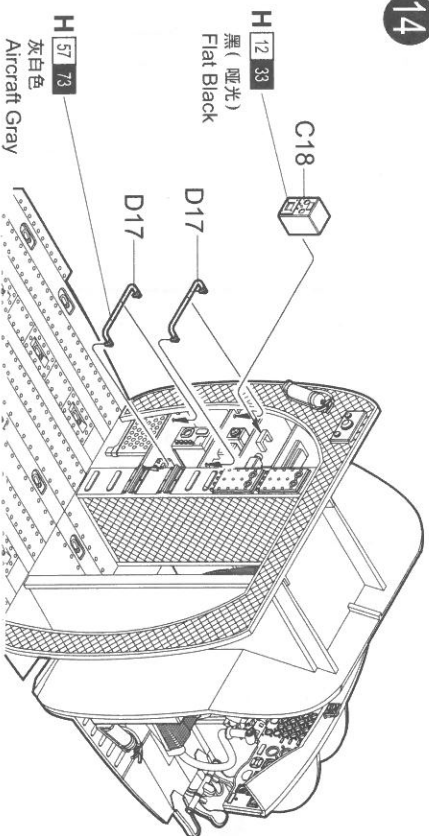

15

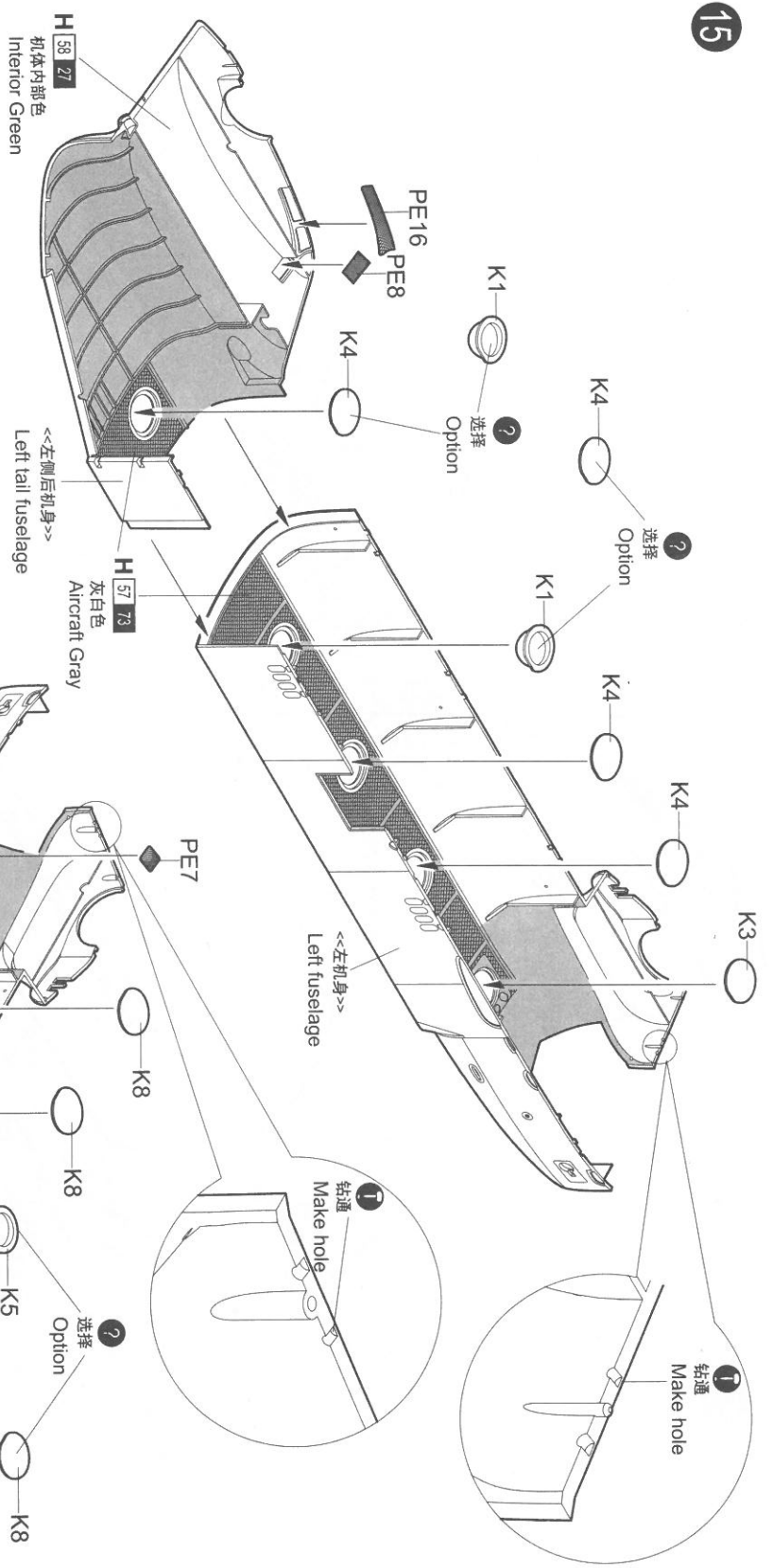

16

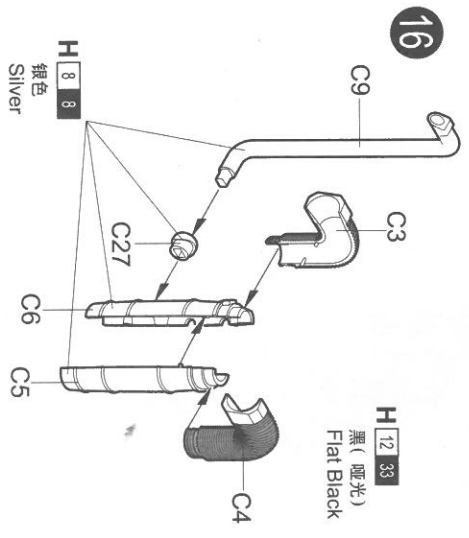

17

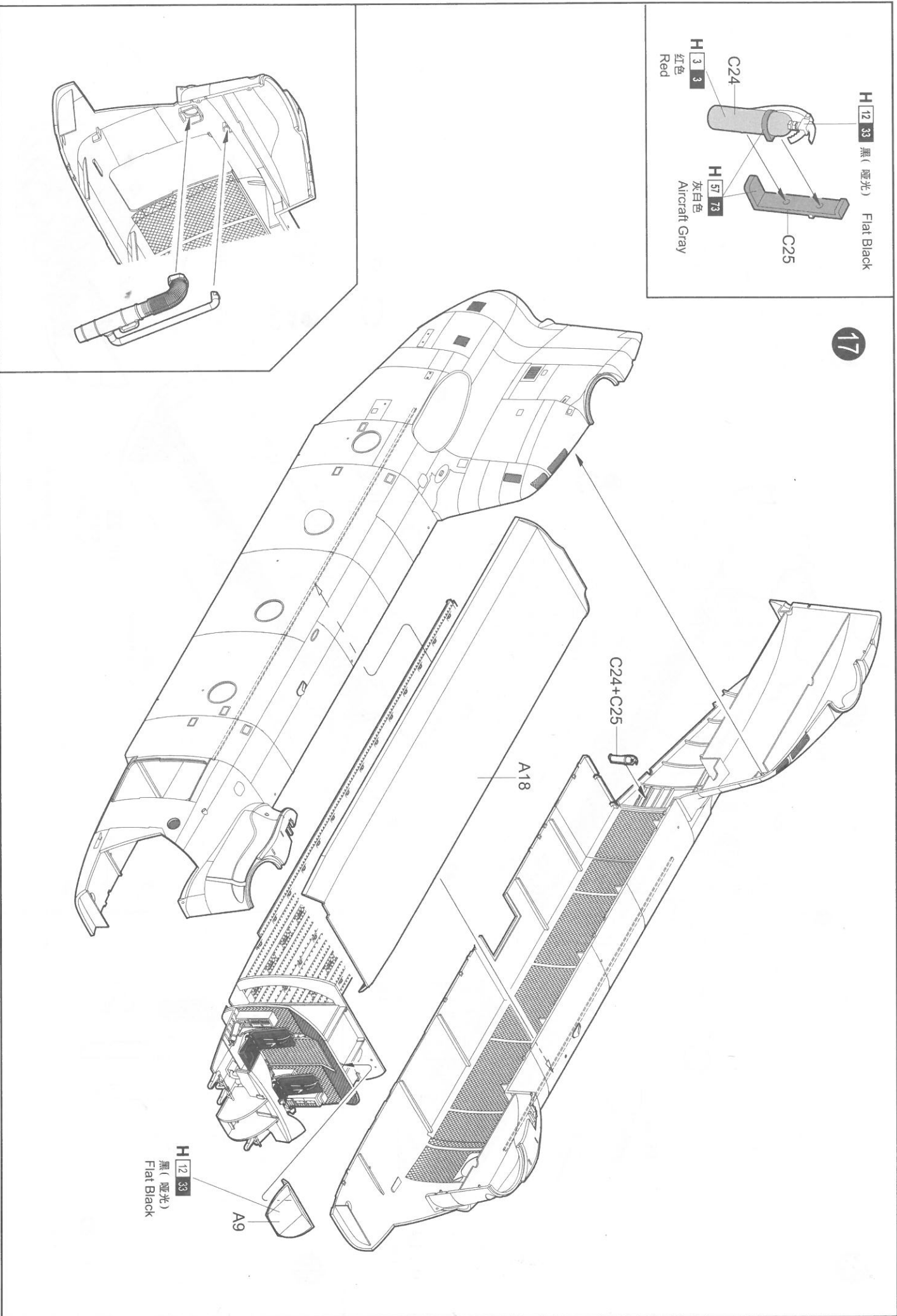
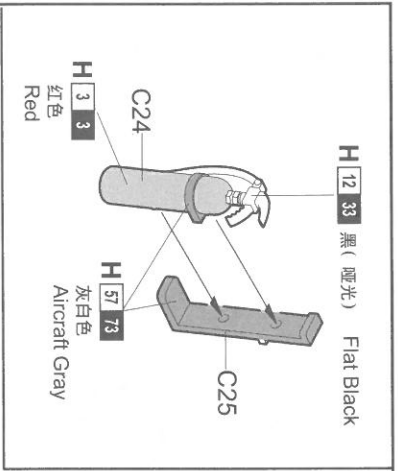

H 12 33 黑 (哑光) Flat Black

18

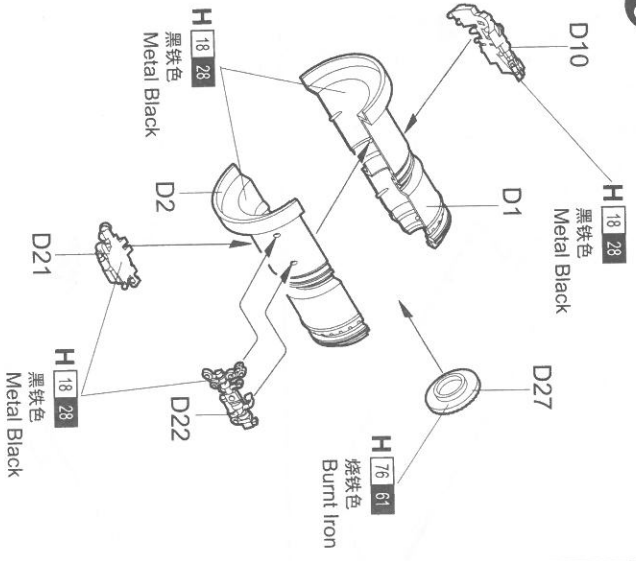

19

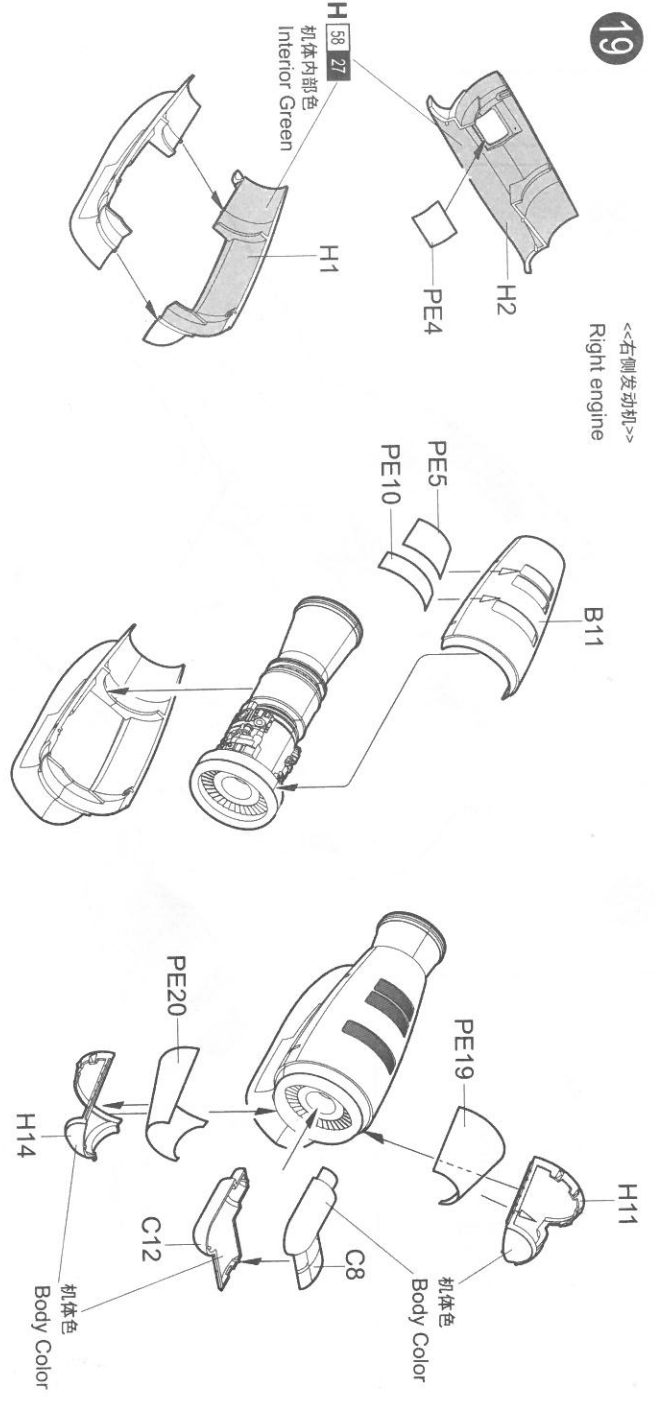

20

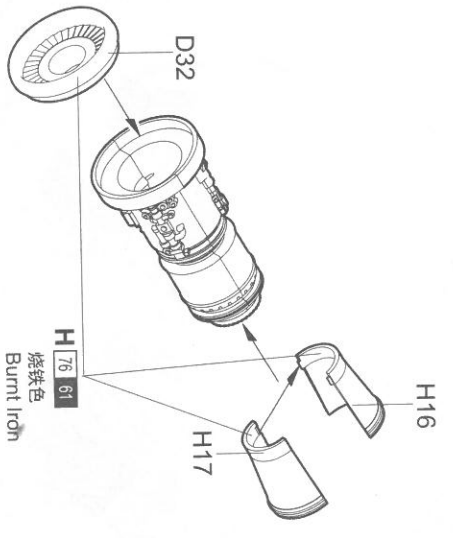
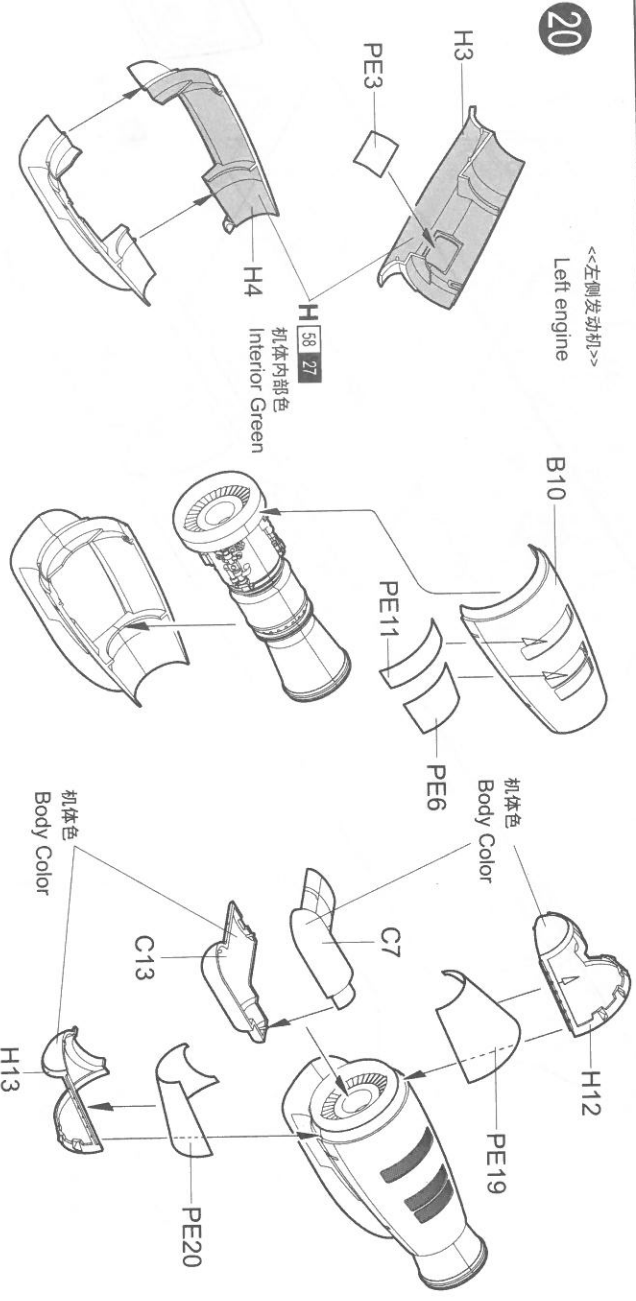

制作两组
Make two

21

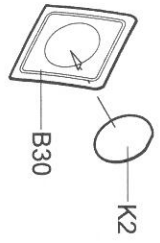

<<右侧发动机>>
Right engine

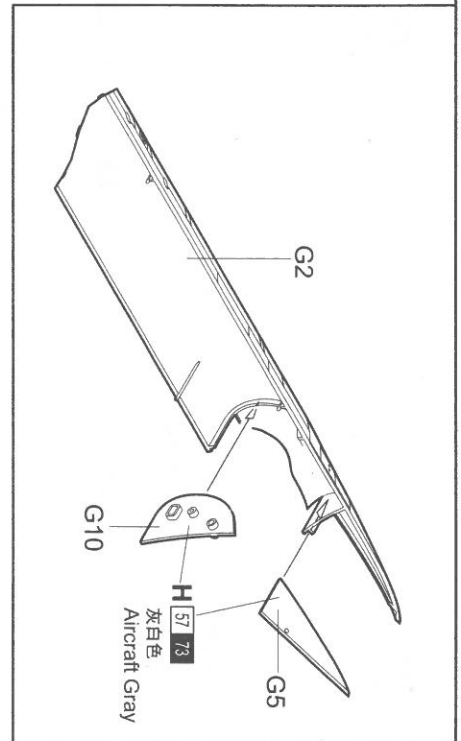
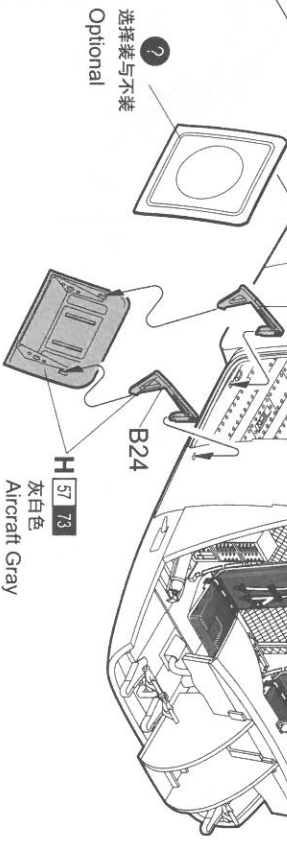
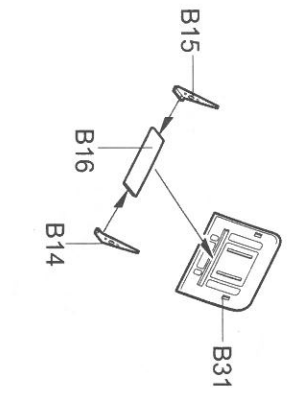
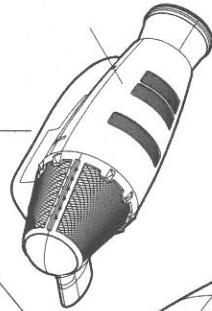

选择装与不装
Optional

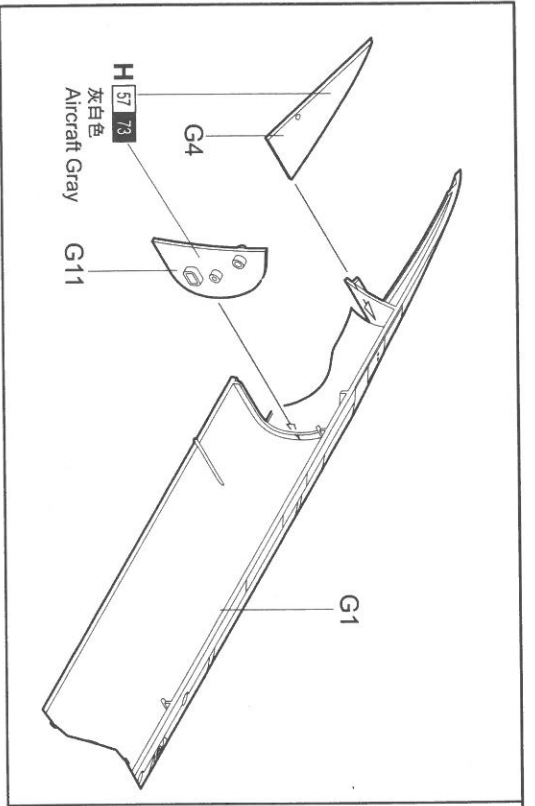

22

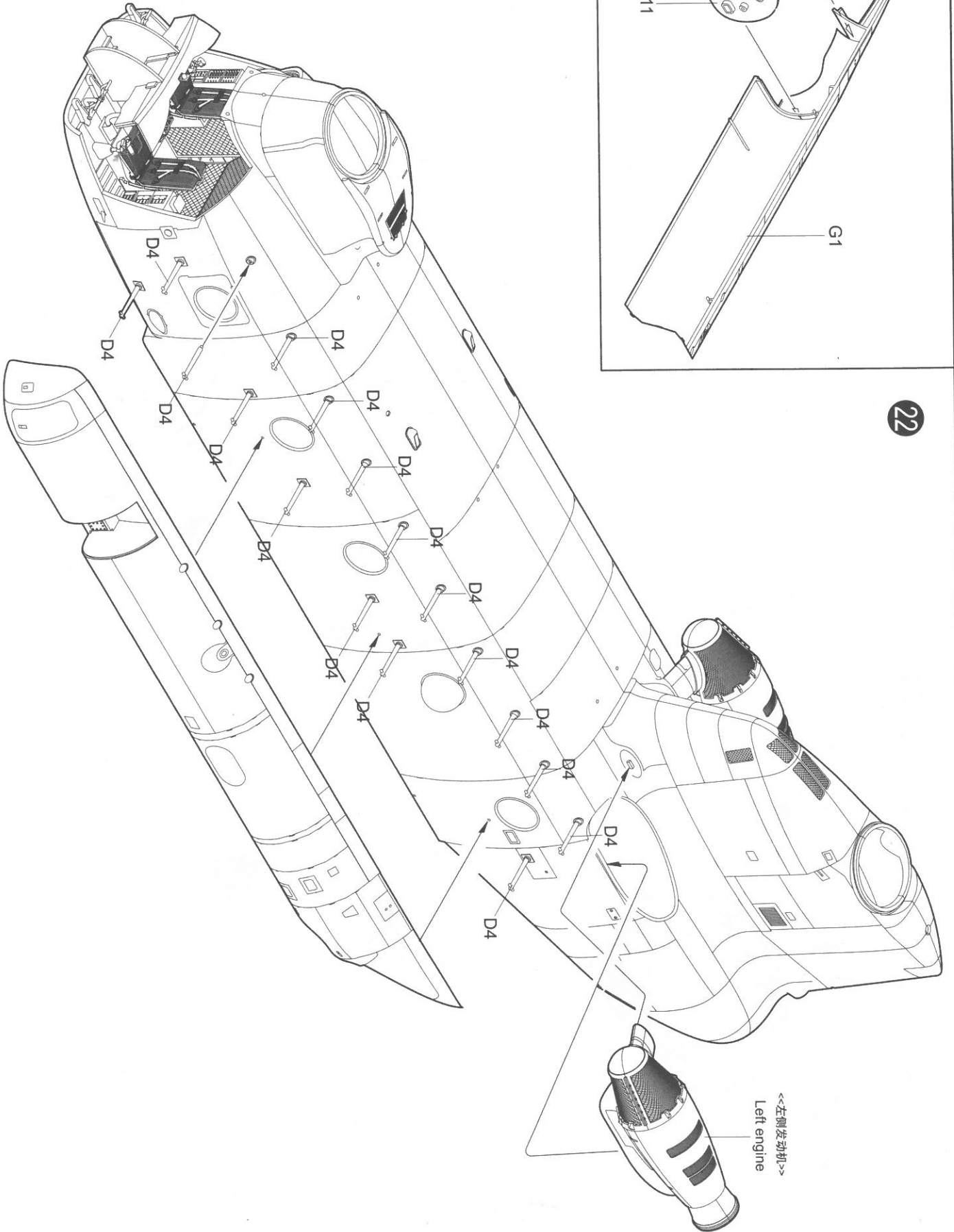

13

23

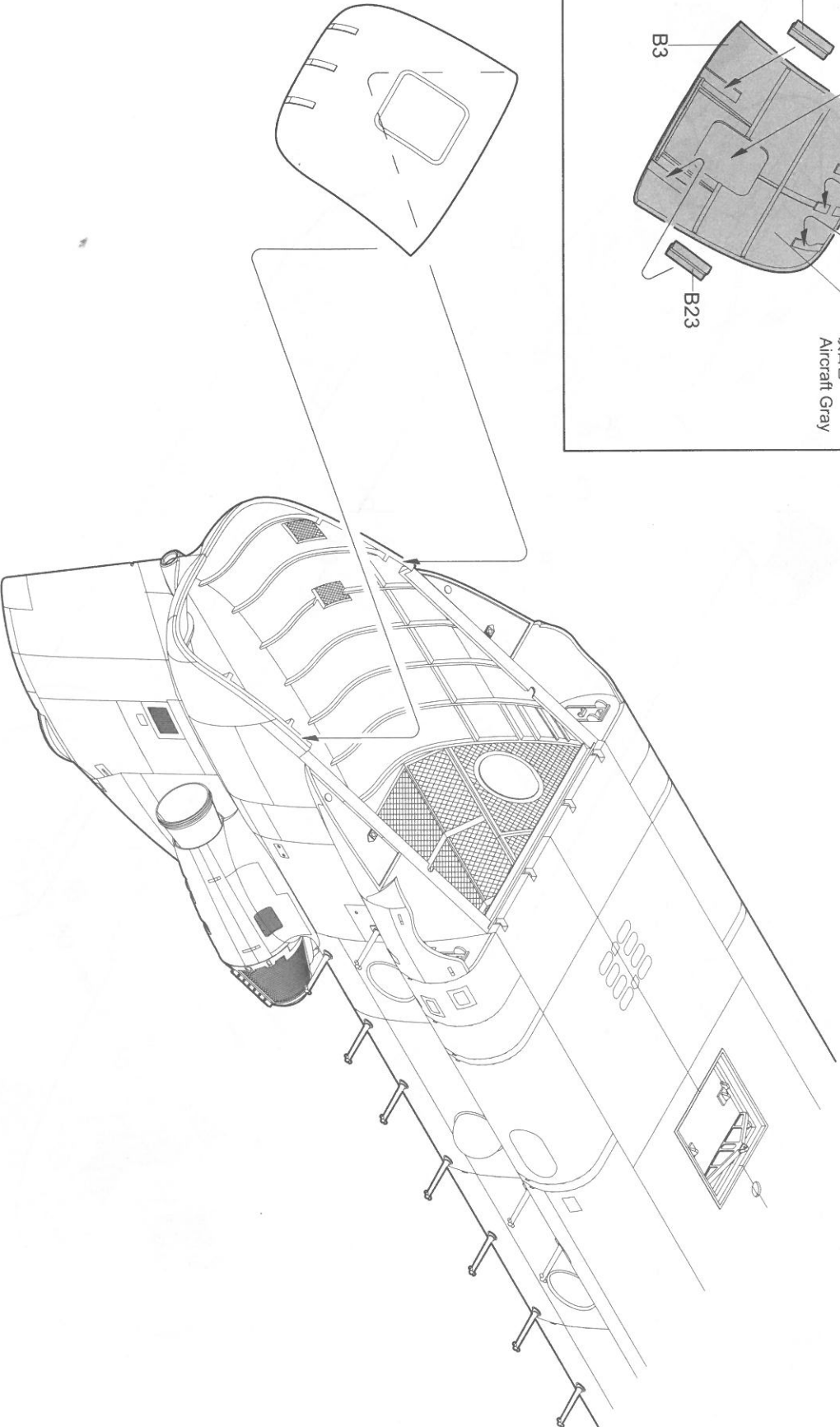
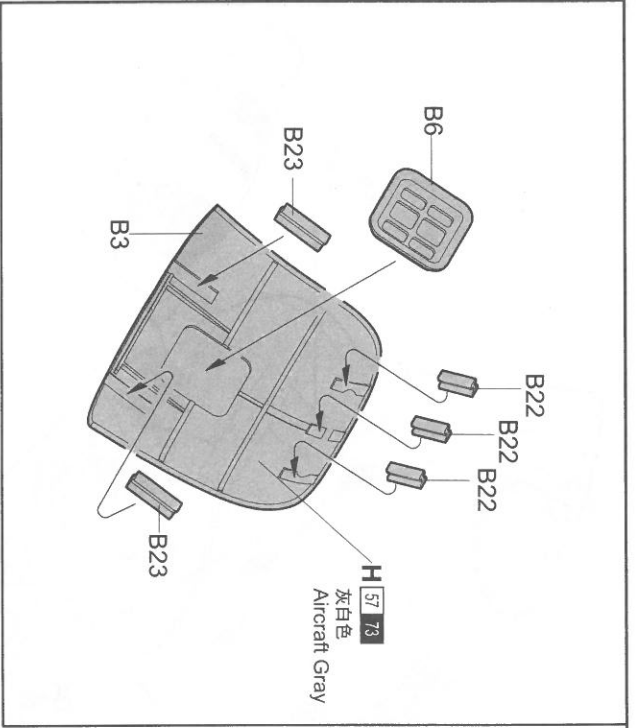

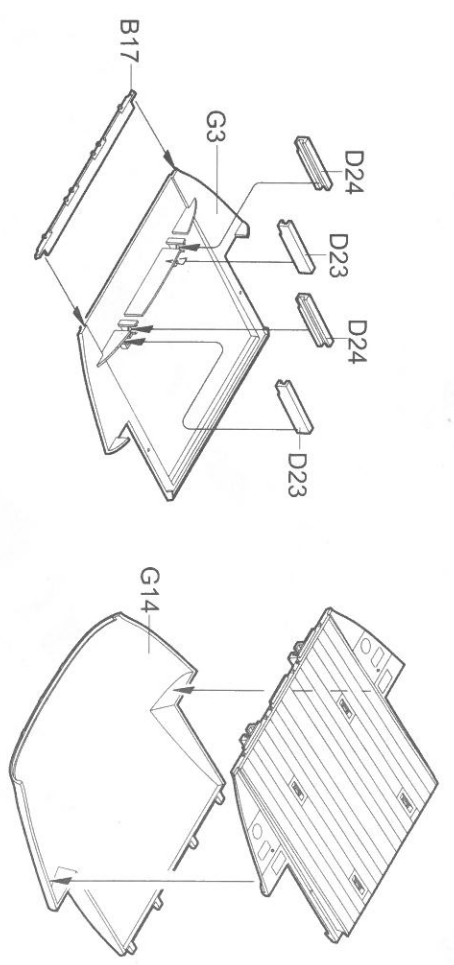
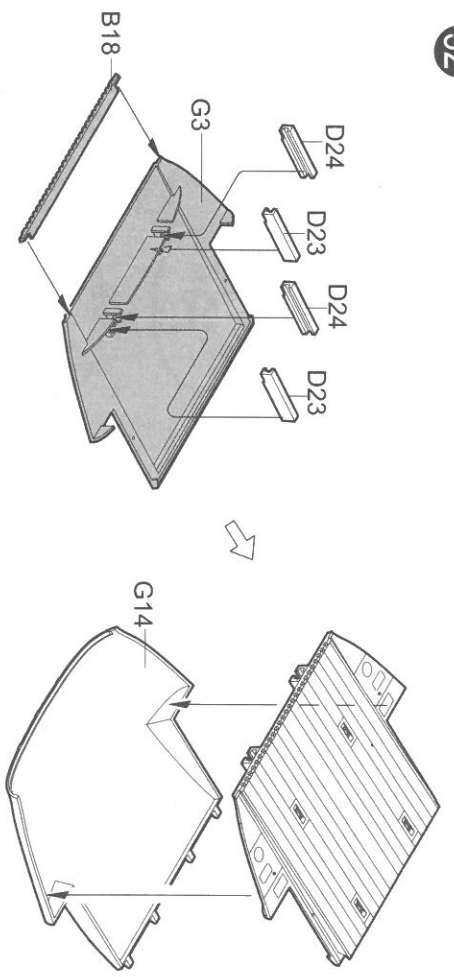

②
可选择
Optional

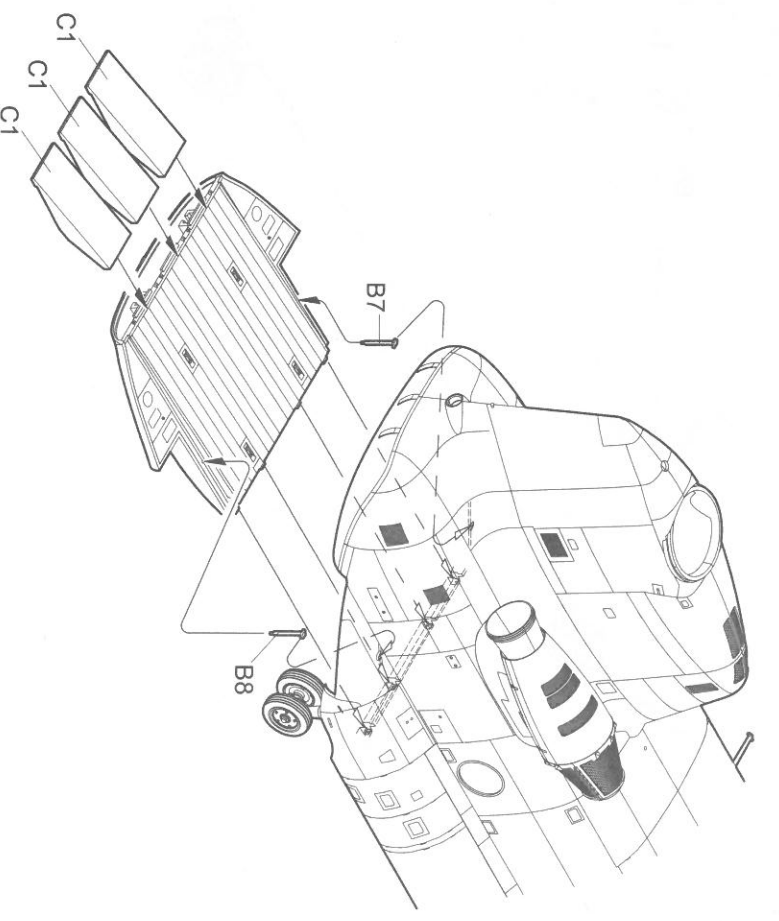
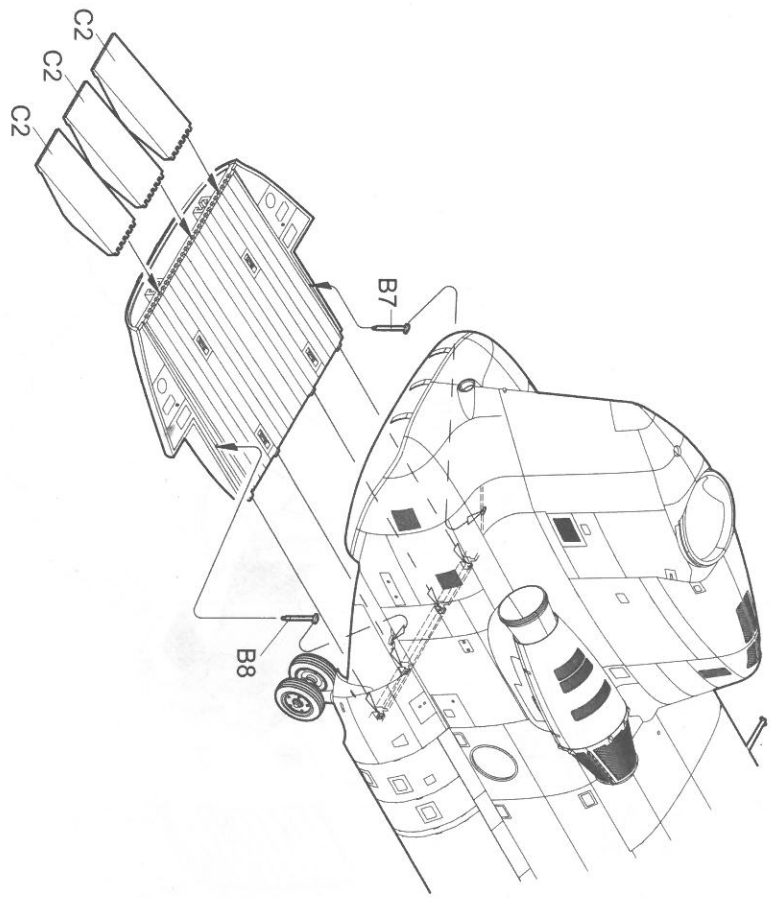

33

L2
H 90 47
透明红
Clear Red

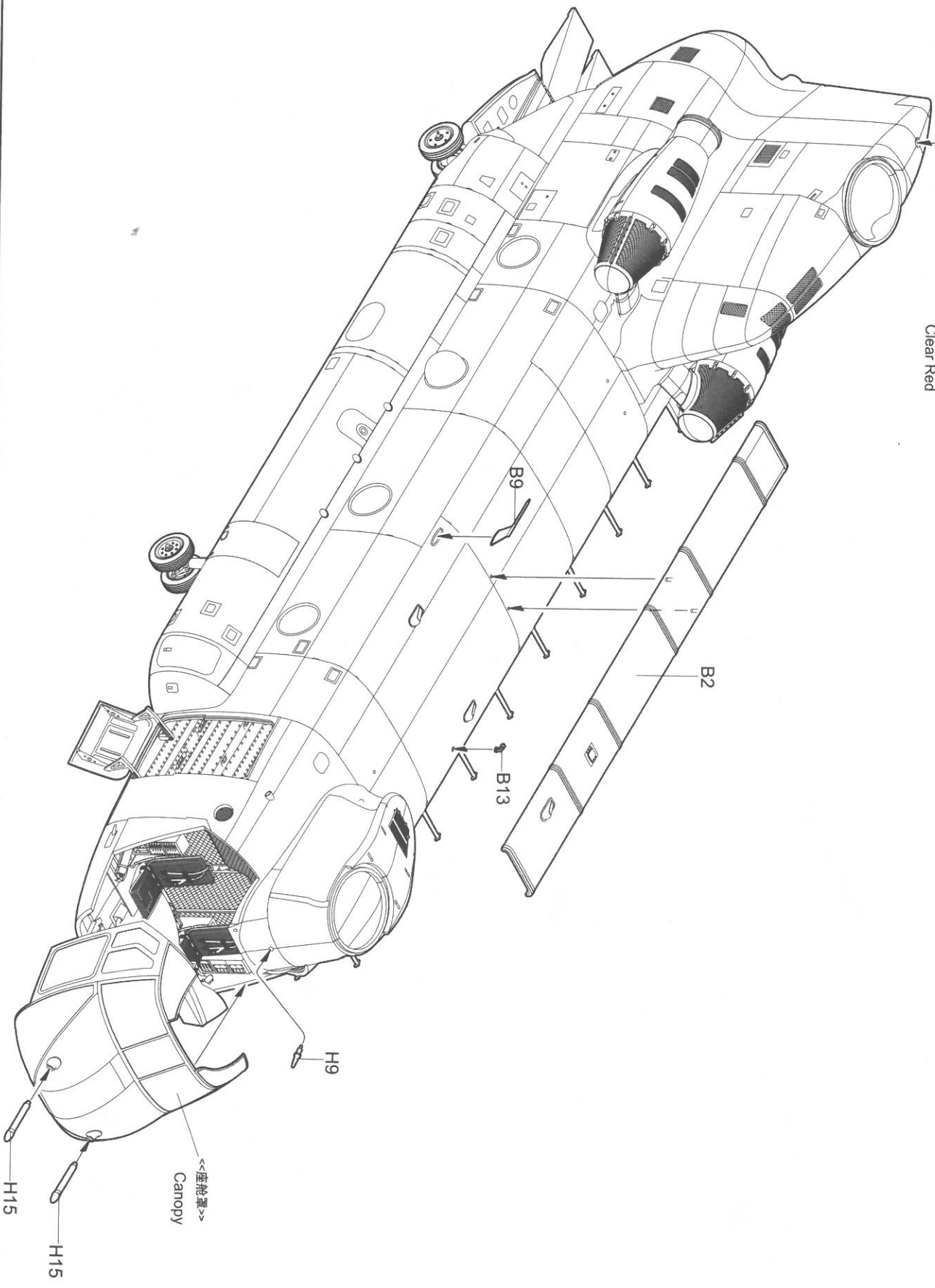

34

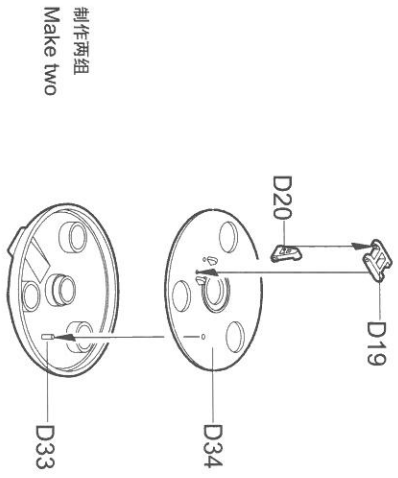

制作两组
Make two

36

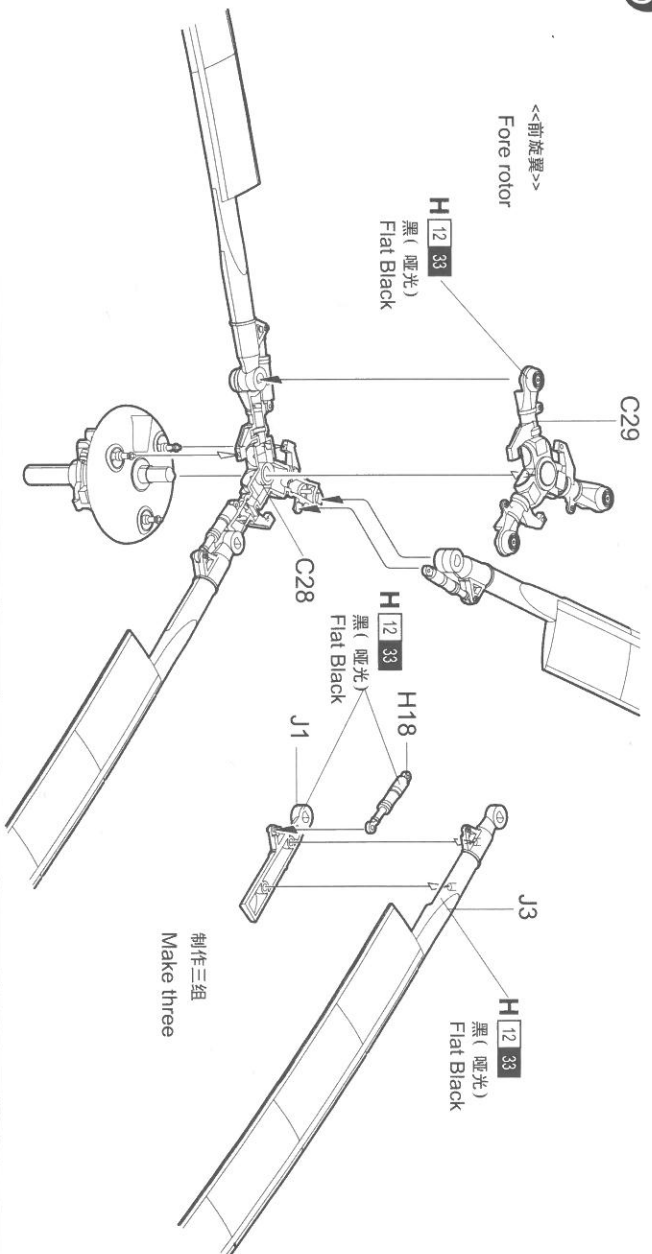

<<前旋翼>>
Fore rotor

制作三组
Make three

35

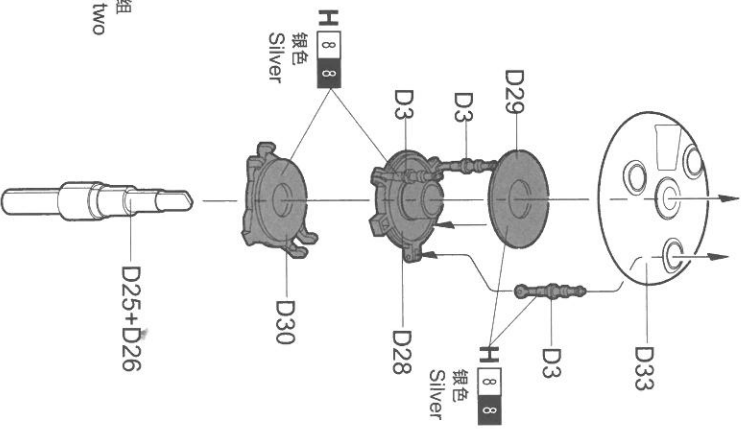

制作两组
Make two

37

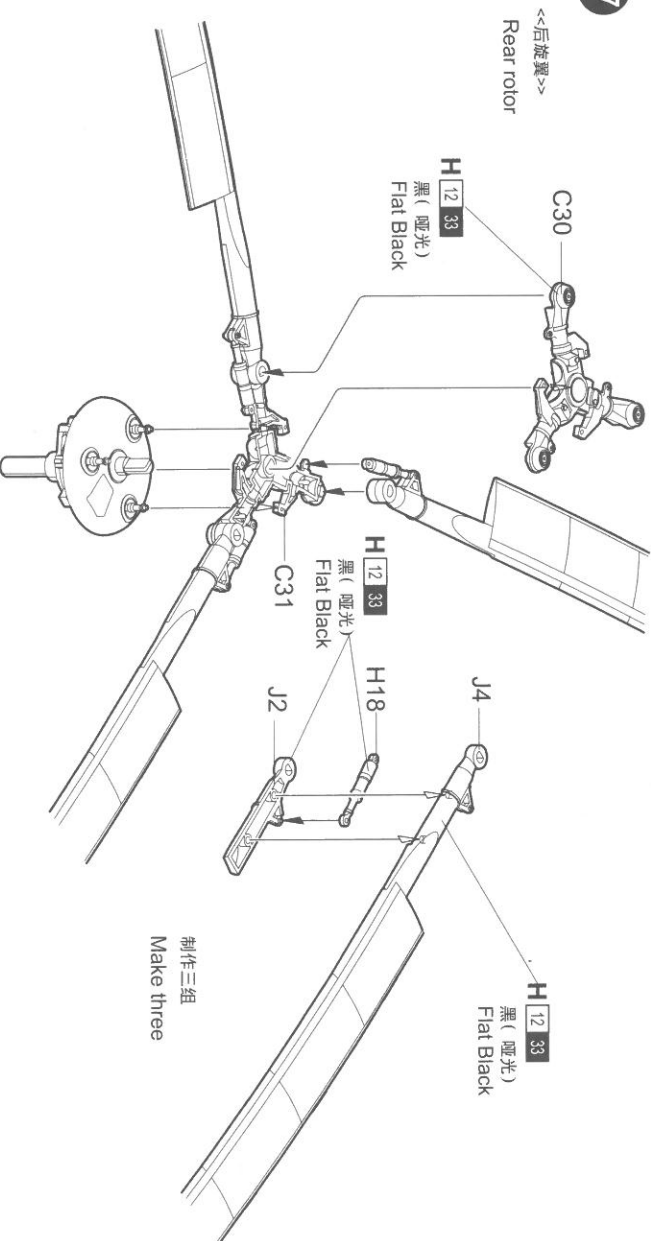

<<后旋翼>>
Rear rotor

制作三组
Make three

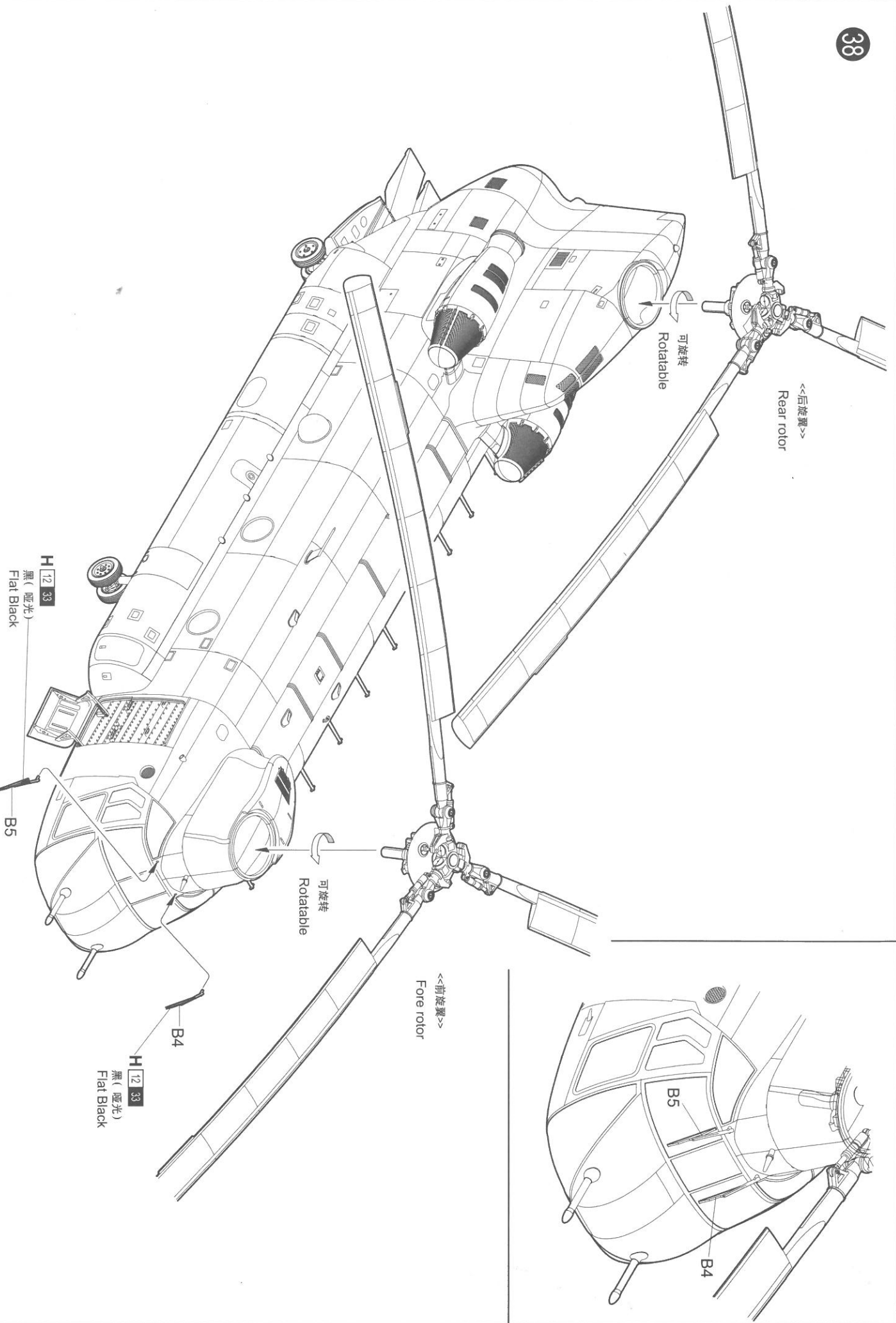

涂装同标贴指示
Painting & Marking guide

使用郡仕公司涂料
GUNZE SANGYO Mr. Color used

