

1:48 Scale

"威灵顿" Mk. I C

"WELLINGTON" Mk.I C

READ BEFORE ASSEMBLY:

- This kit is not recommended for inexperienced modelers or for children under 14 years of age
- Study and understand these instructions thoroughly before beginning assembly
- When needed, remove photo-etch parts carefully using a modeling knife or photo etch sprue cutter, being careful not to damage or lose small parts.
- Take extra care in handling photo etch parts in order to avoid injury
- Apply instant cement sparingly to photo etch parts where instructed

- Tools recommended(not included in kit):Plastic and instant cements,sprue cutters,long nose pliers,modeling knife, small files, tweezers, pin vise & scissors. Soft cloth and sandpaper will also assist in construction
- Glue and paint are not included in the kit. Use plastic cement and hobby paints only. Color guide for purchasing paint is included in the kit.
- Keep out of reach of small children. They must not be allowed to ingest small parts or handle plastic bags in any way.

装配之前仔细阅读

- 小心用模型锉刀锉平所有零件表面的注射浇口。
- 小心用刀片切下蚀刻片零件，不要遗失小零件。
- 用强力快干胶水粘合蚀刻片零件和金属轴。过量的快干胶水使用可能导致可动零件会粘住，小心涂胶。
- 取蚀刻片时应特别注意安全，防止利边划伤手指。
- 某些零件表面需贴上水贴纸，请选择在装配的同时进行。
- 推荐模型工具(自备)：胶水，水口剪刀，长咀钳，刀片，锉刀，镊子钳，钻，剪刀，瞬间快干胶。
- 软布同砂纸同时也应该是必备工具。
- 请使用塑料胶水和油漆，模型内不含。
- 谨防小孩吸吮塑料零件，或者将塑料袋套在头上，制作时应将套材远离小孩接触。
- 本产品不适合14岁以下没有经验的模型爱好者。

水贴纸的使用:

1. 从水贴上剪下印花;
2. 将印花放入温水中浸10秒, 然后放在干净布上。
3. 拿着印花纸板将印花移到模型上;
4. 手指蘸水将印花移到适当的位置;
5. 用软布轻压印花直至水干, 汽泡消失。

DECAL APPLICATION:

1. Cut decals from sheet as needed
2. Dip the decal in warm water for about 10 seconds and then place on soft clean cloth.
3. Hold the decal backing sheet edge and gently slide the decal onto the model in its proper position.

4. While still wet, decal can be adjusted for better fit on model by dampening it gently with your finger.
5. When placed in the proper position, gently press decal down with a soft cloth until excess water and air bubbles are gone.
6. Allow decal to dry completely before handling model



cyanoacrylate glue
使用强力胶



weight
配重



make hole
钻孔



cut / remove
切除



option
选择



no cement
不涂胶水



decal
贴纸



bend
弯曲



file / sand
锉平

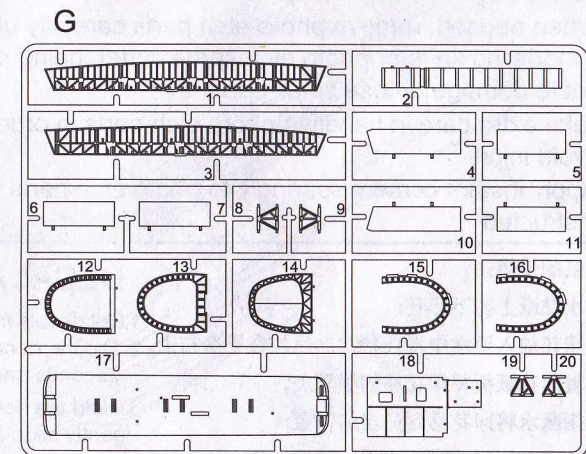
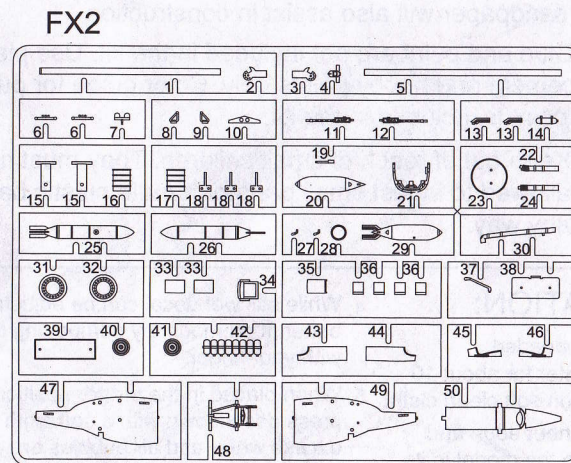
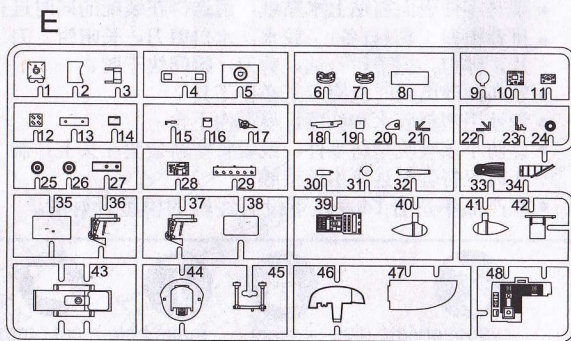
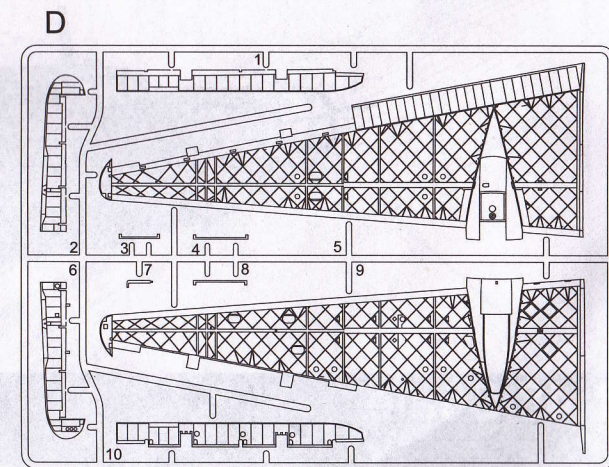
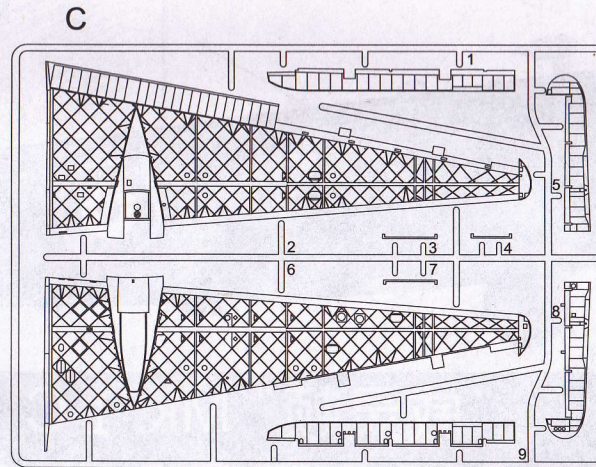
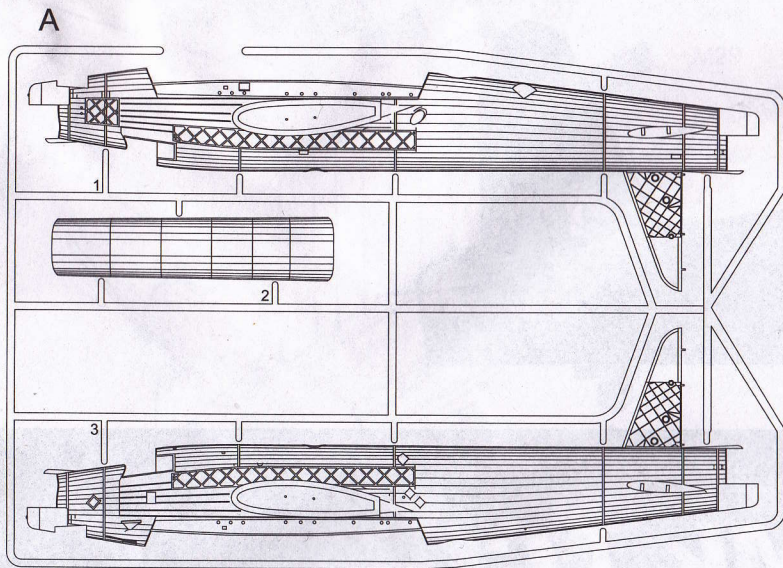

H

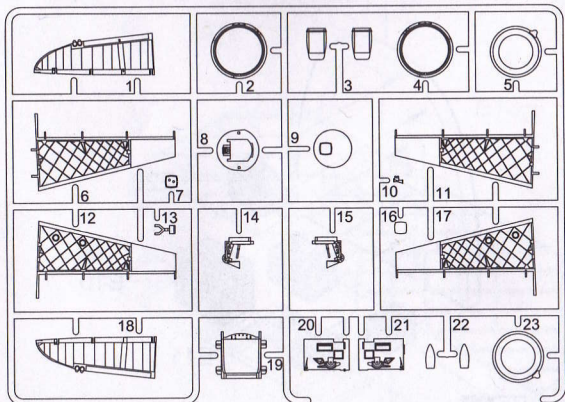

K X3

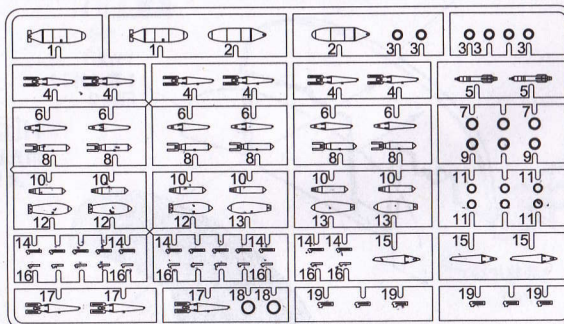

蚀刻片
Photo Etched parts(PE)

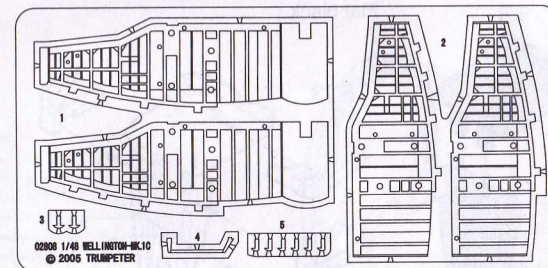

菲林片
Film parts

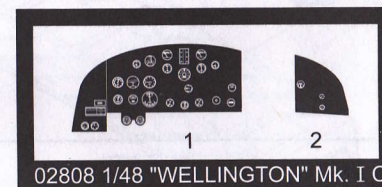

M

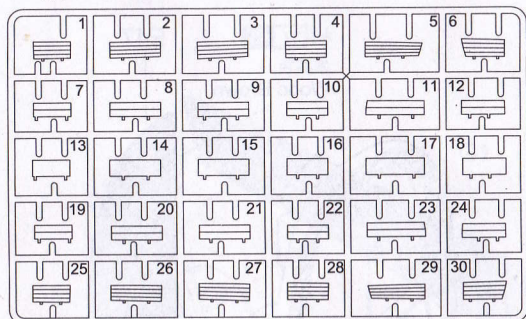

P X2

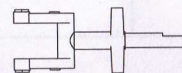
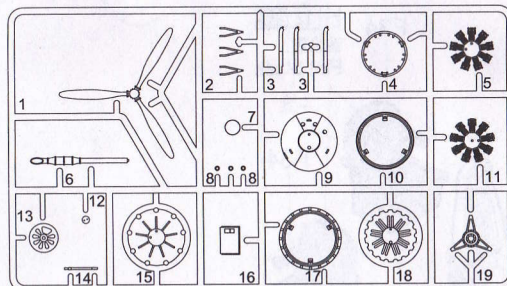

后起落架
Tail undercarriage



尾轮胎
Tail tire

主轮胎
Main tires

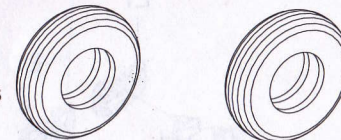

R

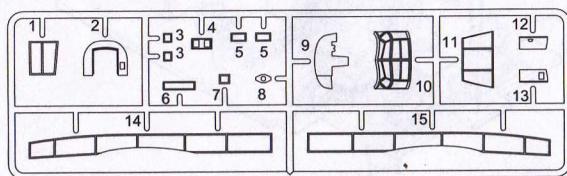

T

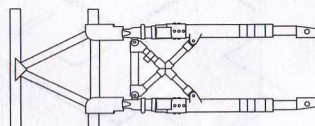
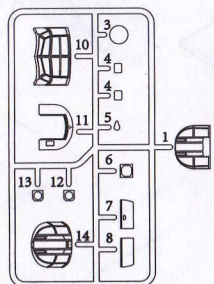

主起落架
Main undercarriage X2

水贴纸
Decal



轴: \varnothing 1.0X10.0mm 2PCS
Shaft: \varnothing 1.0X8.0mm 1PCS

1

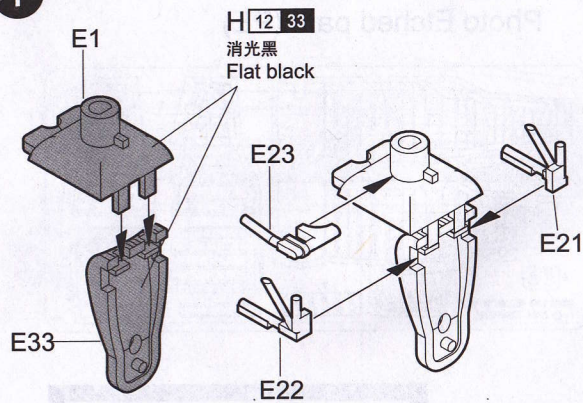

2

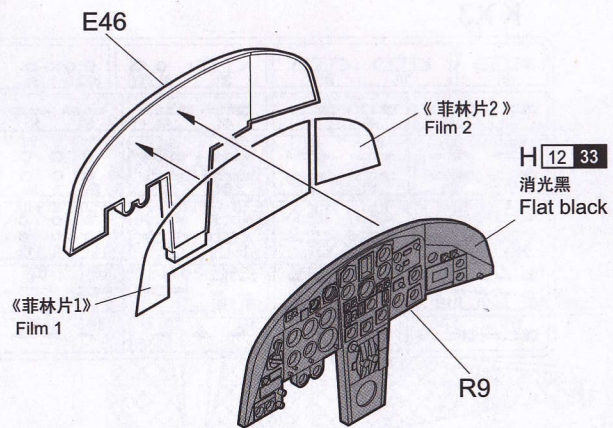

3

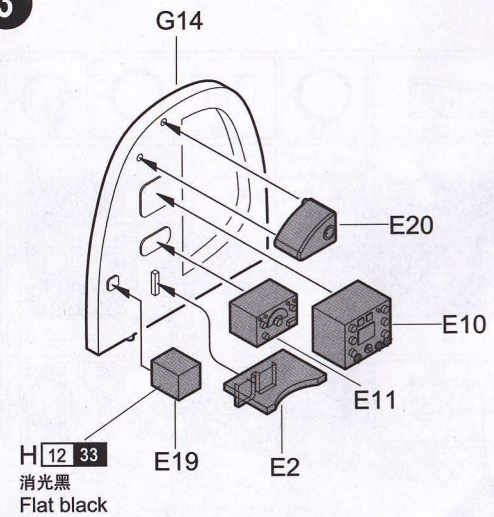

4

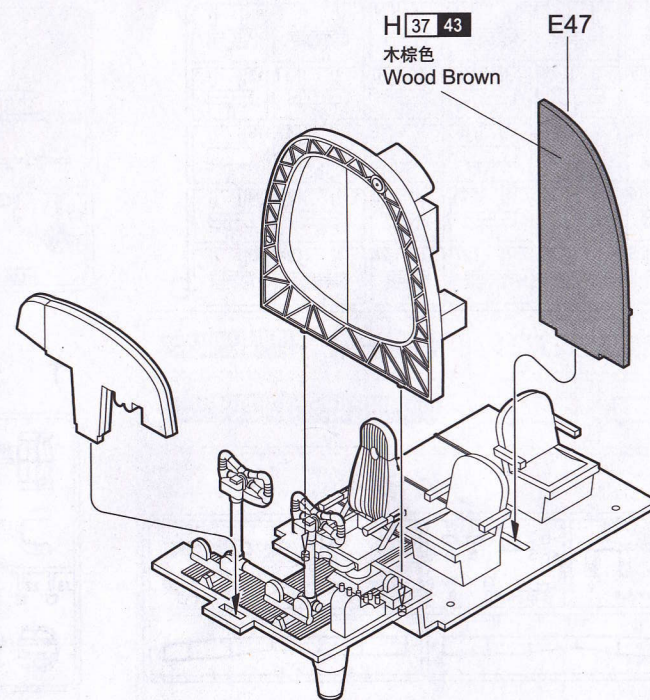
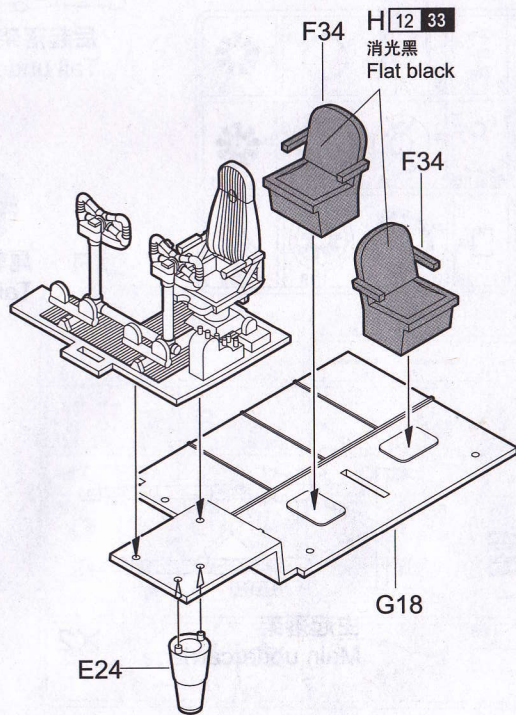
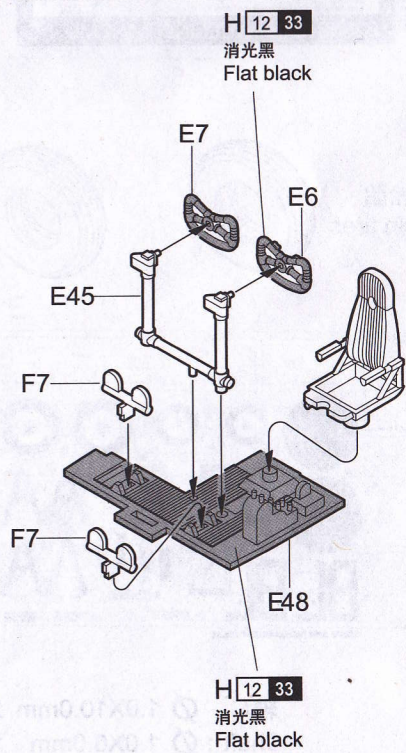

5

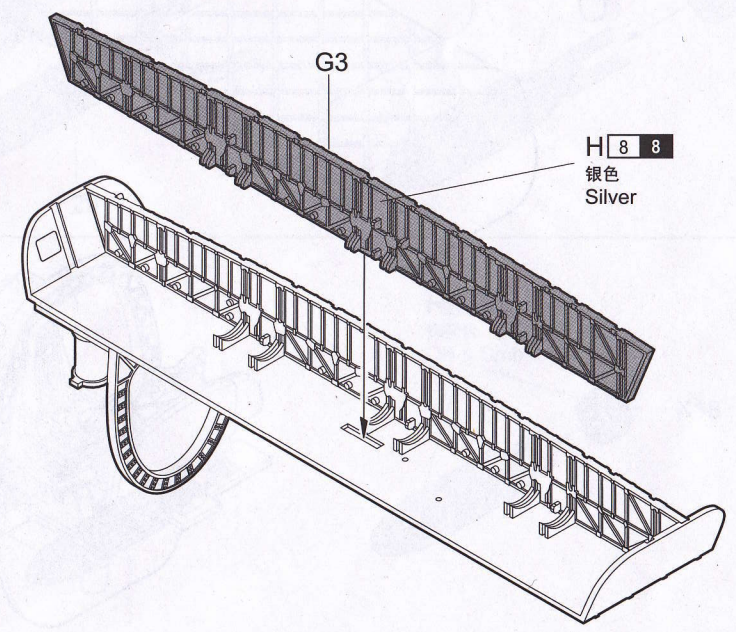
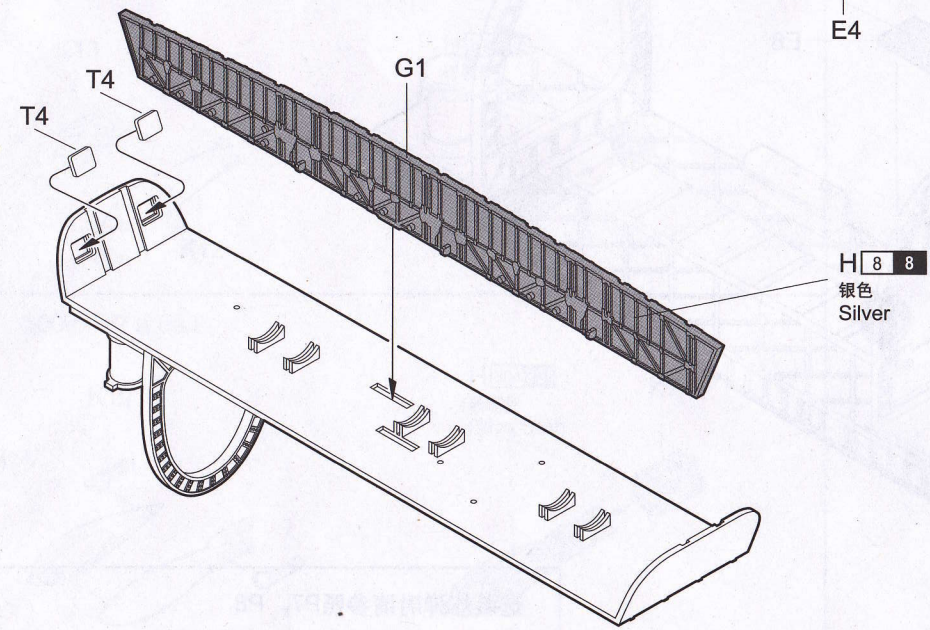
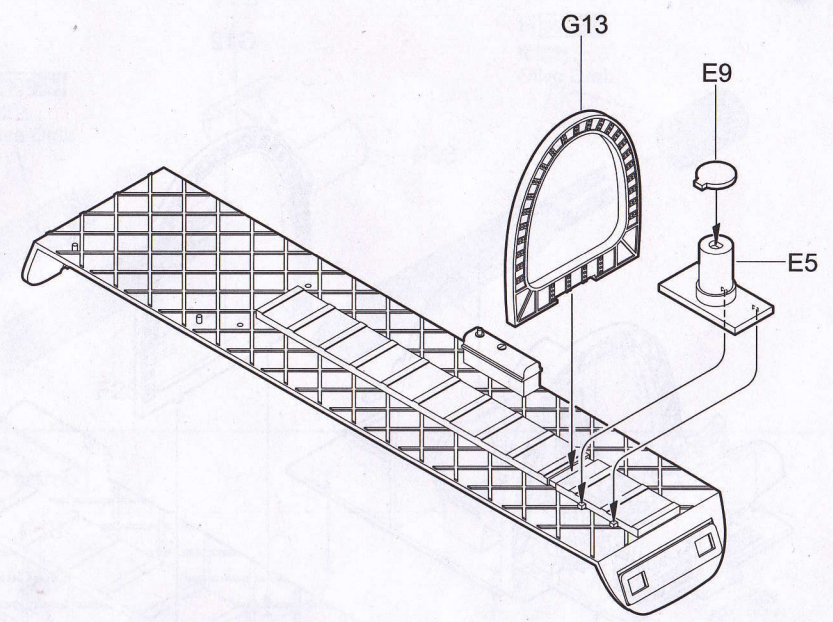
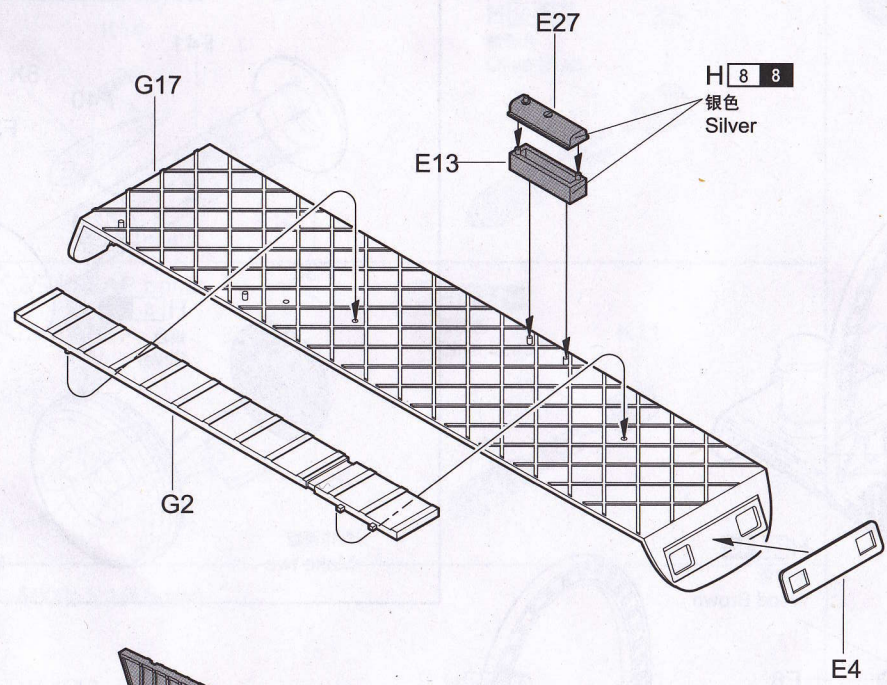

6

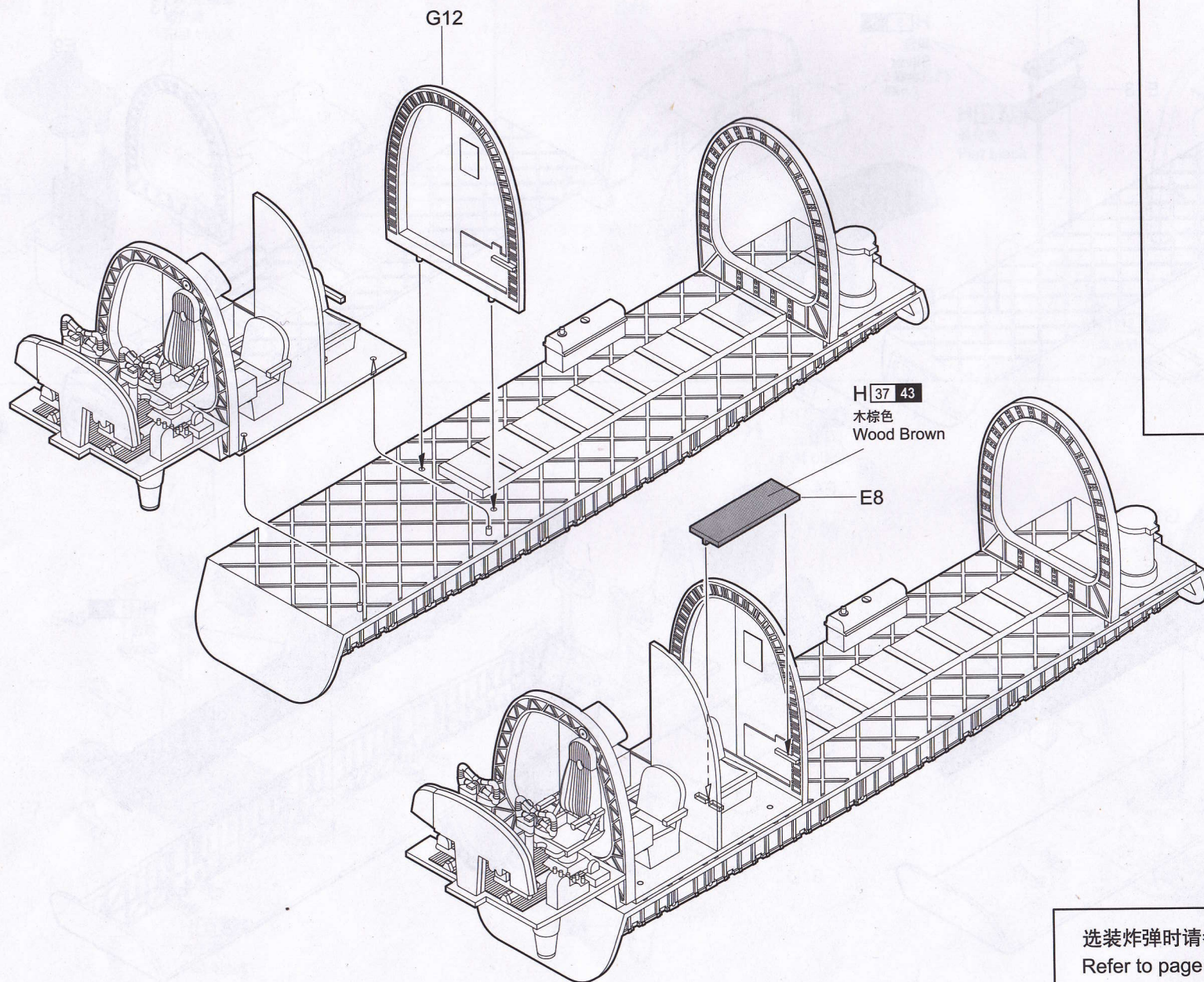

《主轮》
Main gear

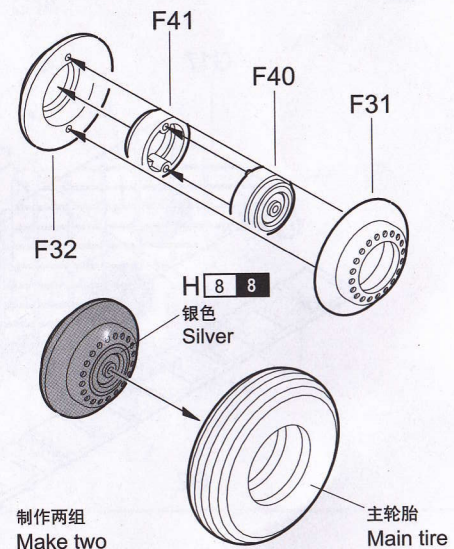

选装炸弹时请参照P7, P8
Refer to page 7 & page 8 if attaching bombs

7 250lb GP bomb

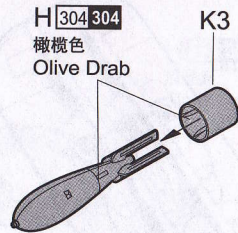
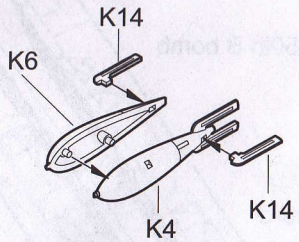

8 250lb SAP bomb

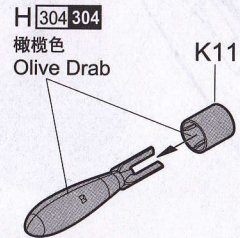
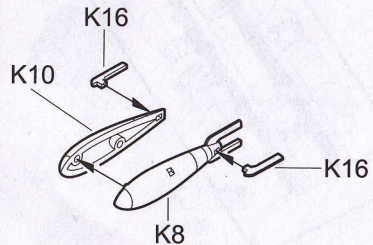

9 500lb SAP bomb

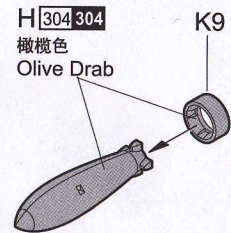
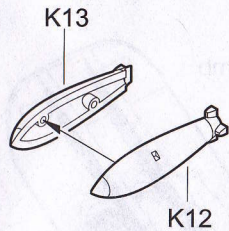

10 500lb GP bomb

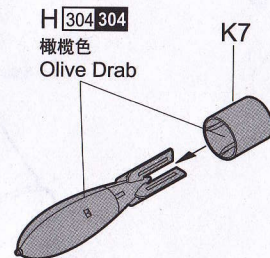
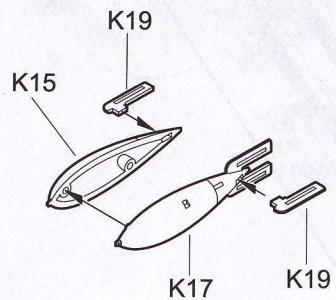

11 2000lb AP bomb

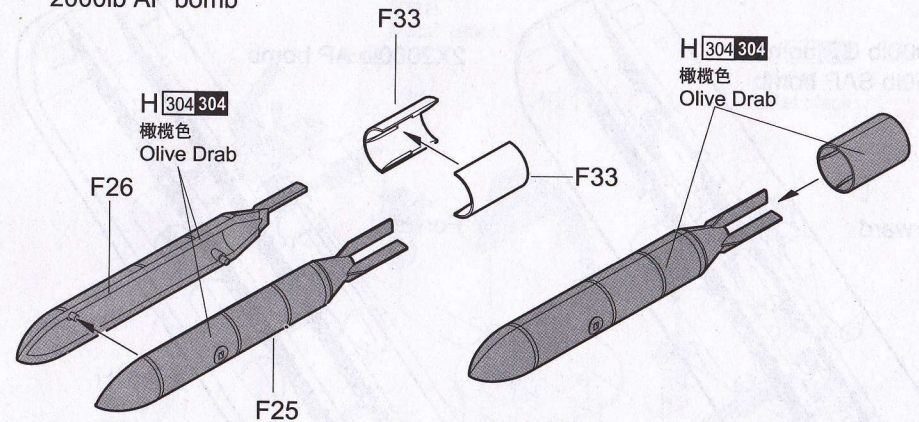

12 1000lb GP bomb

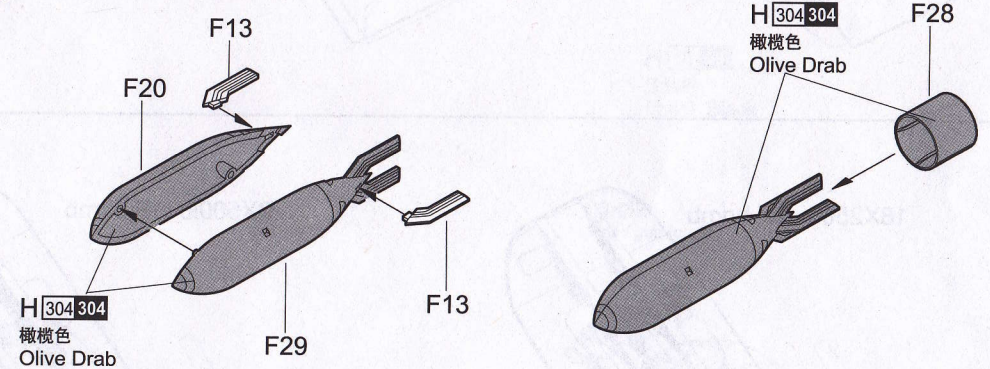

13 250lb B bomb

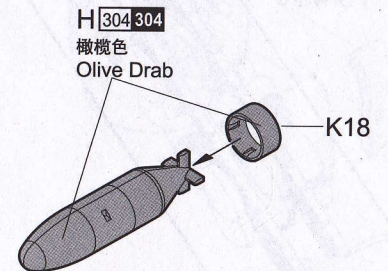
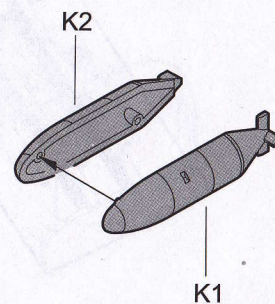

14

2X1000lb GP bomb,
6X250lb SAP bomb

Forward

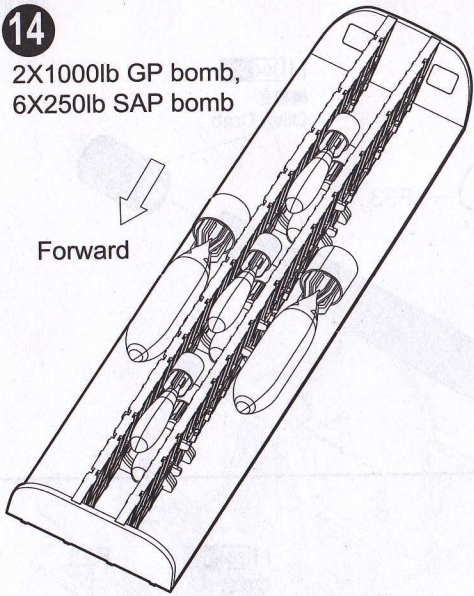

2X2000lb AP bomb

Forward

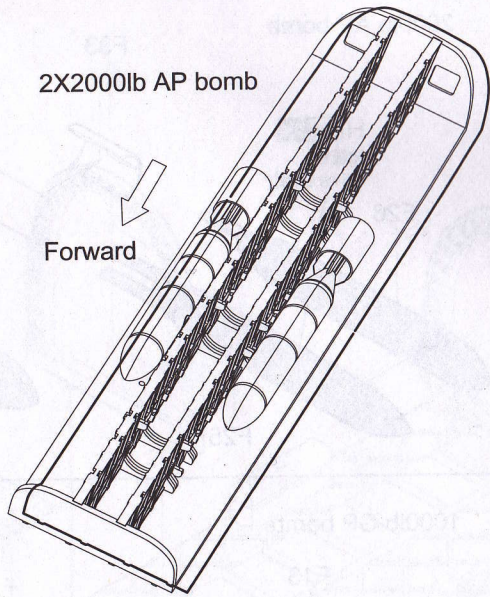

18X250lb SAP bomb

Forward

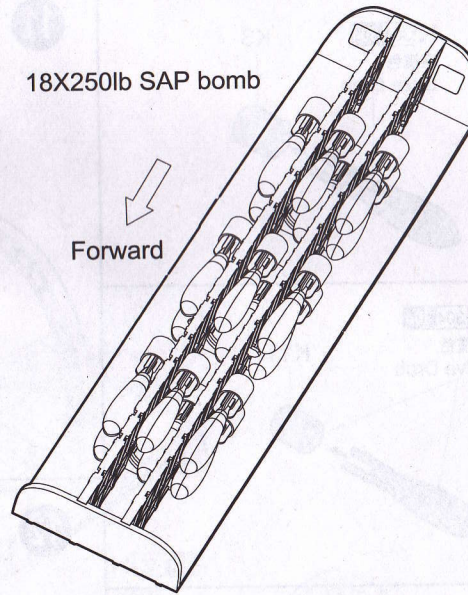

6X250lb B bomb

Forward

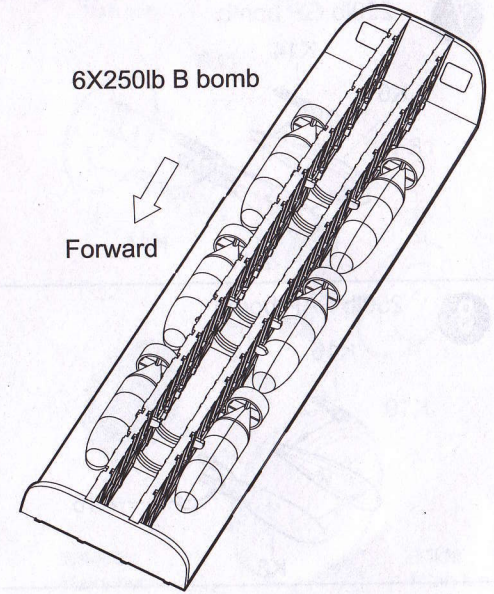

18X250lb GP bomb

Forward

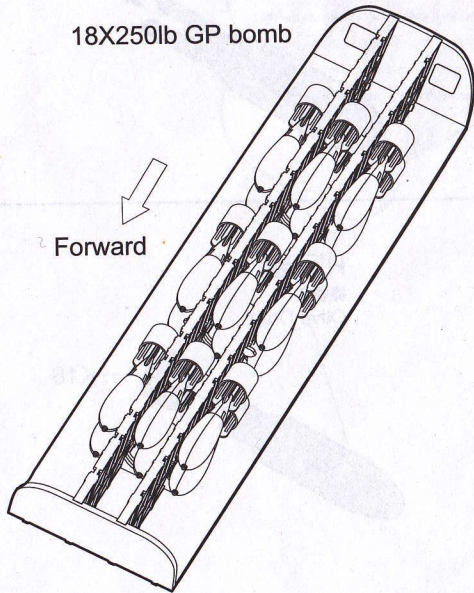

9X500lb GP bomb

Forward

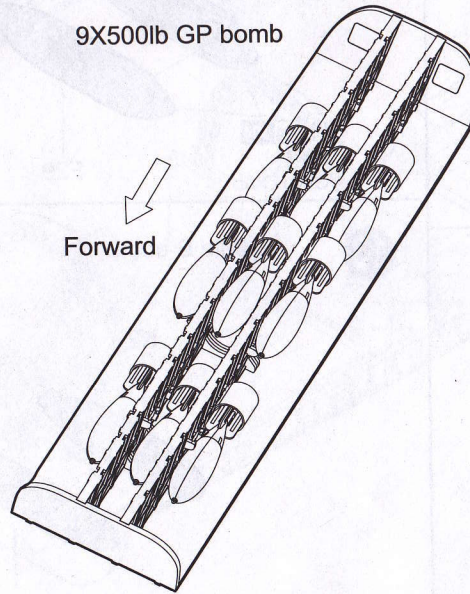

9X500lb SAP bomb

Forward

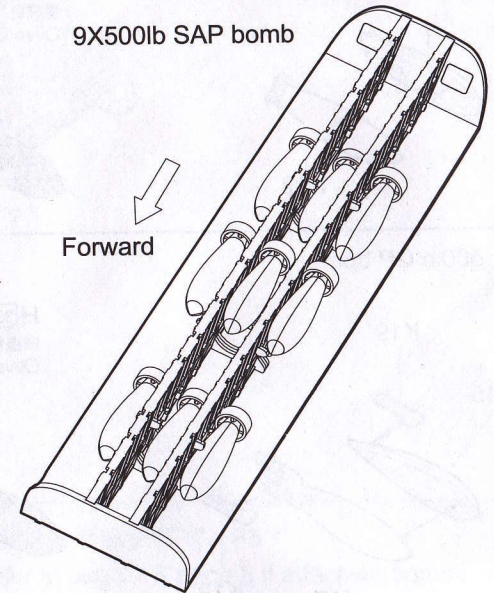

15

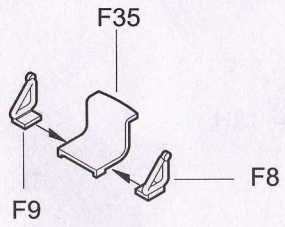

制作2套
Make two

H 12 33
消光黑
Flat black

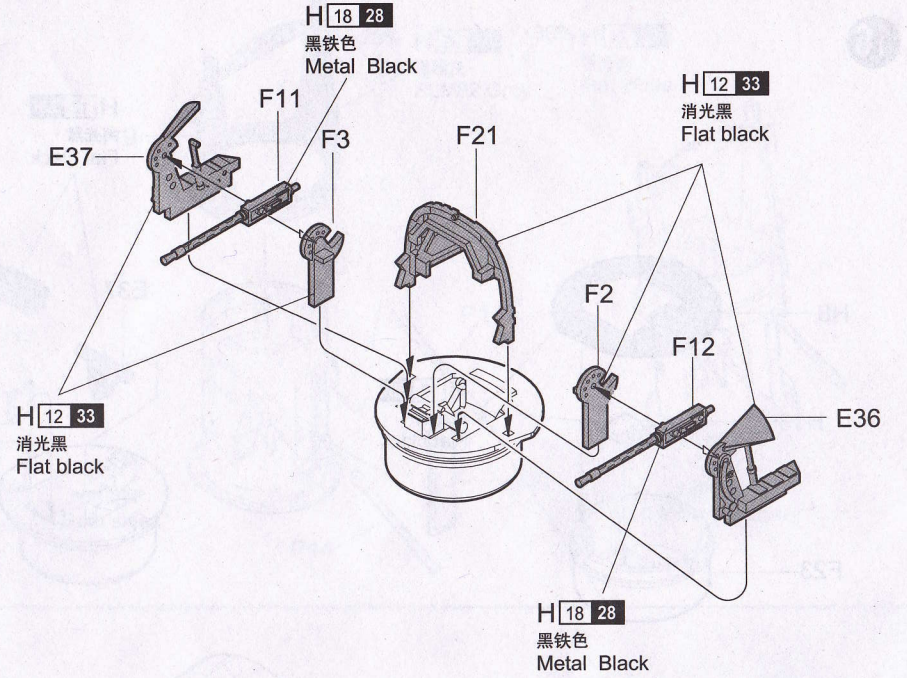
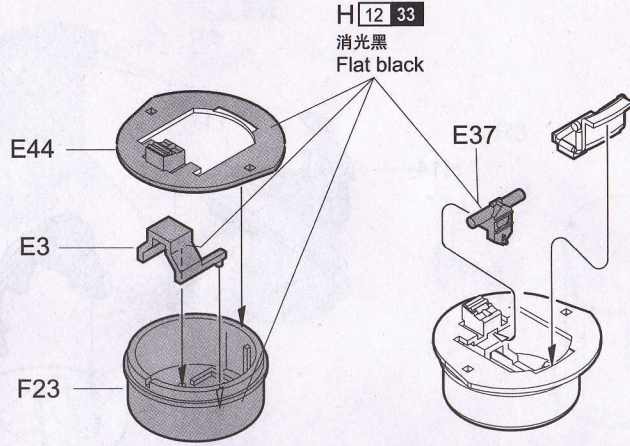

《前炮塔》
Nose gun turret

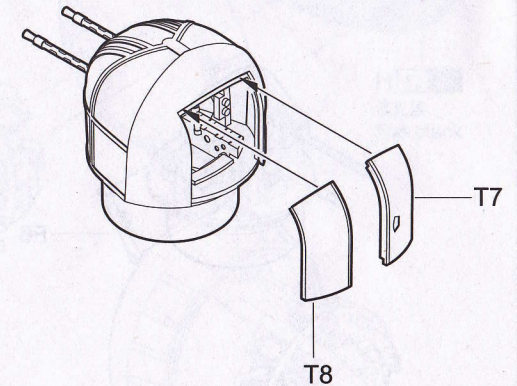
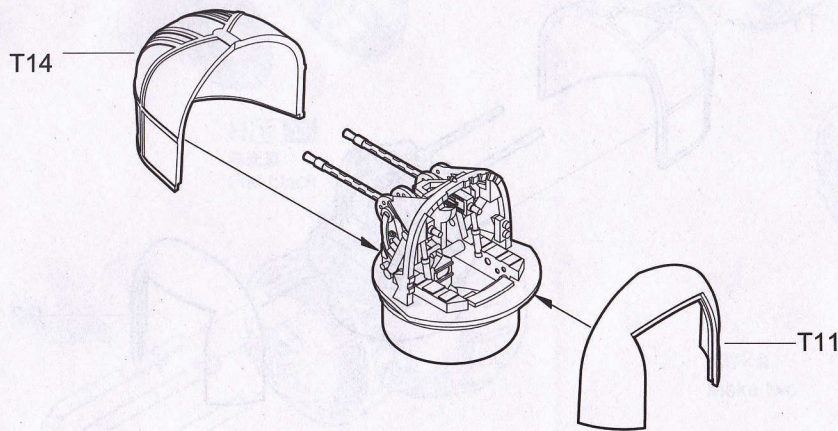
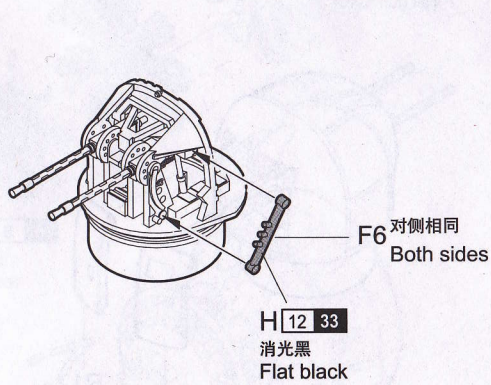

16

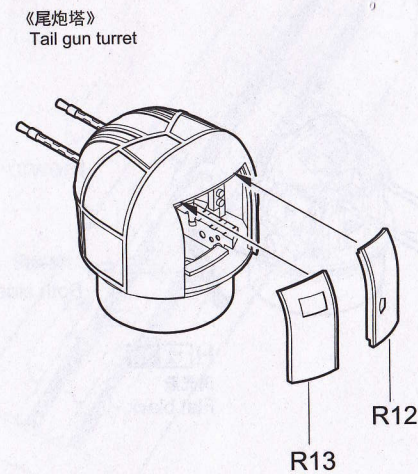
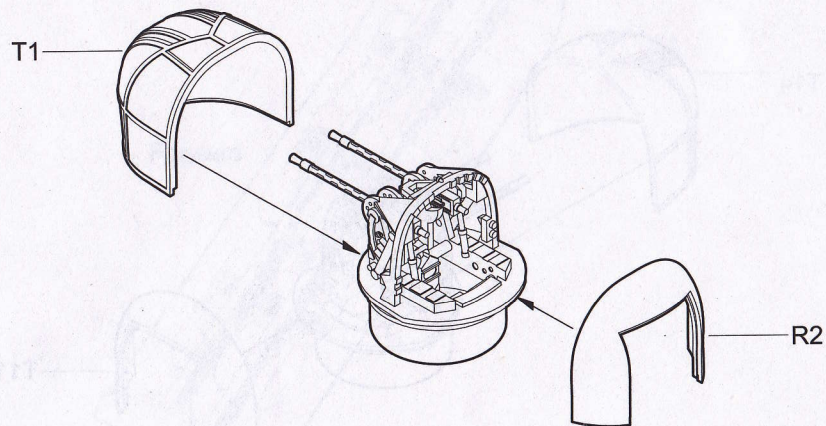
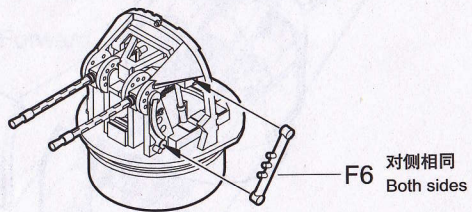
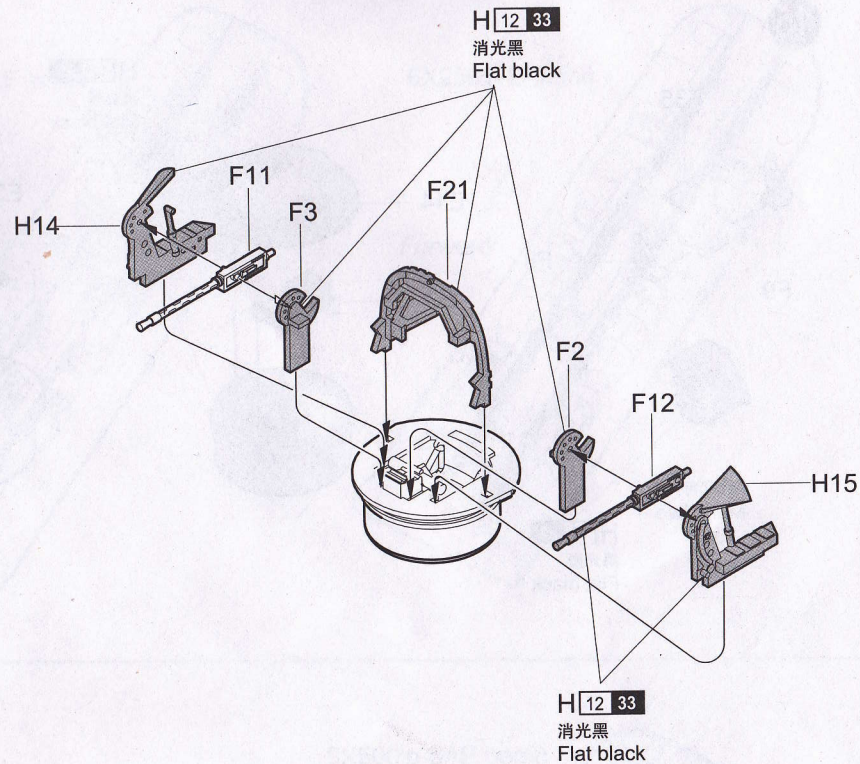
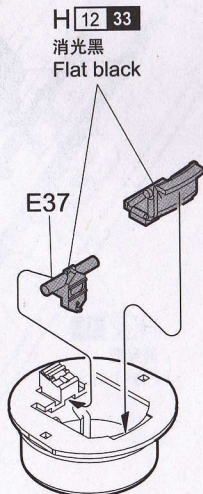

17

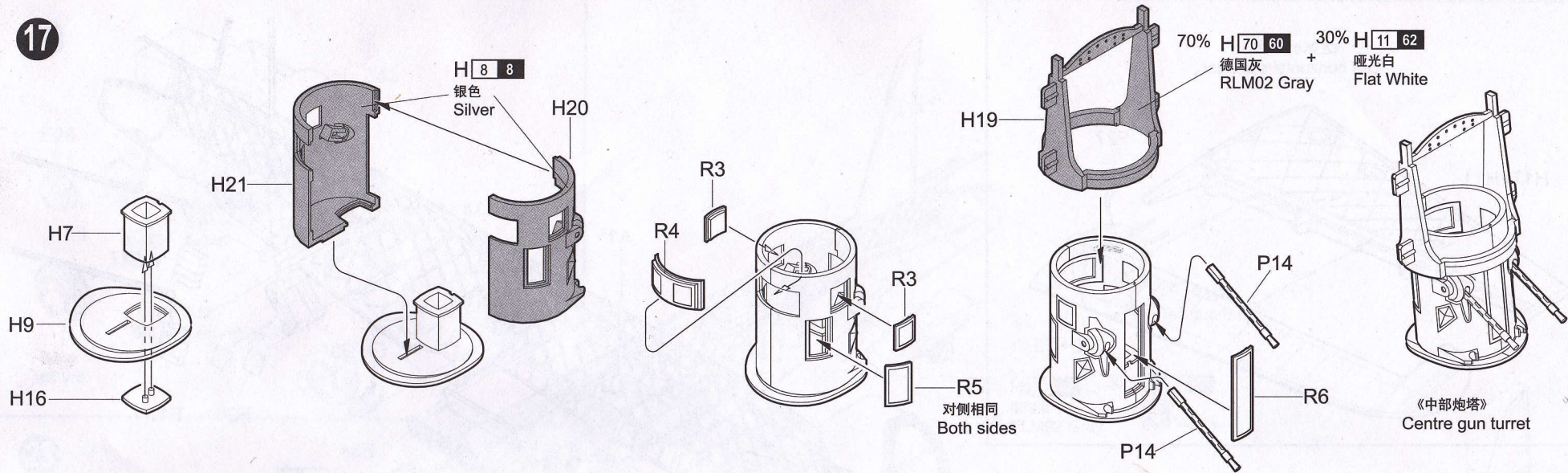

18

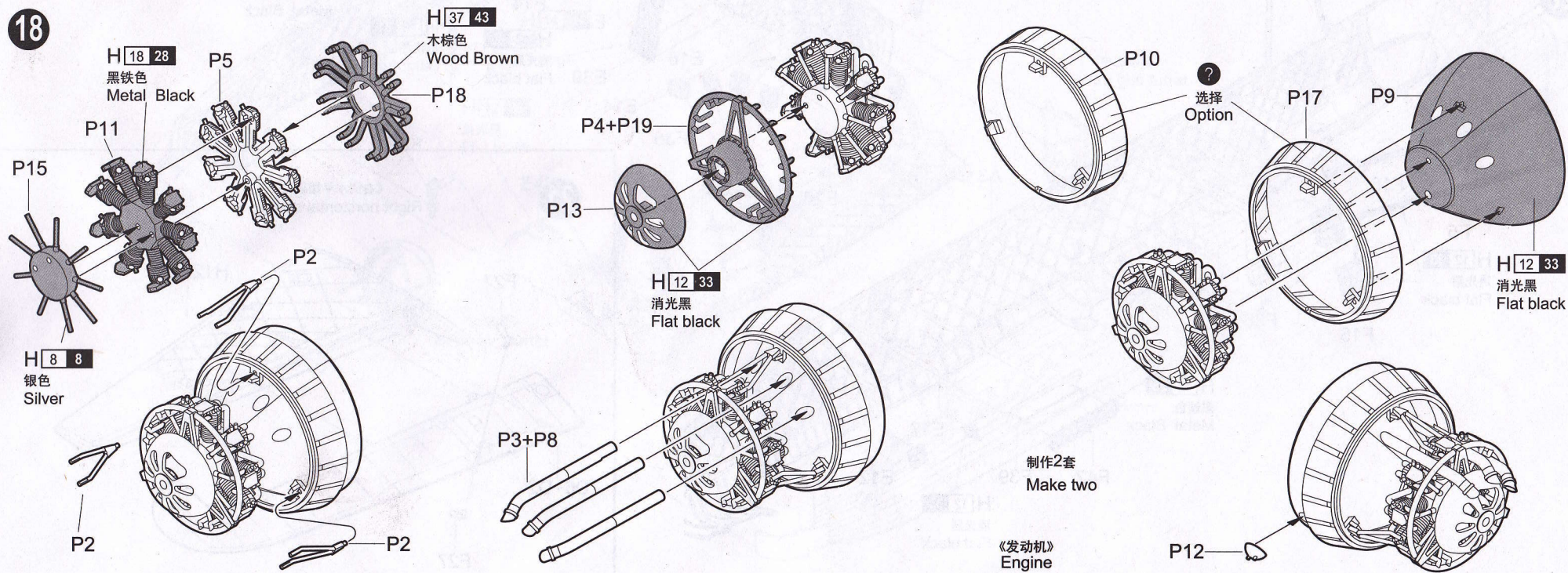

19

《左侧水平尾翼》
Left horizontal stabilizer

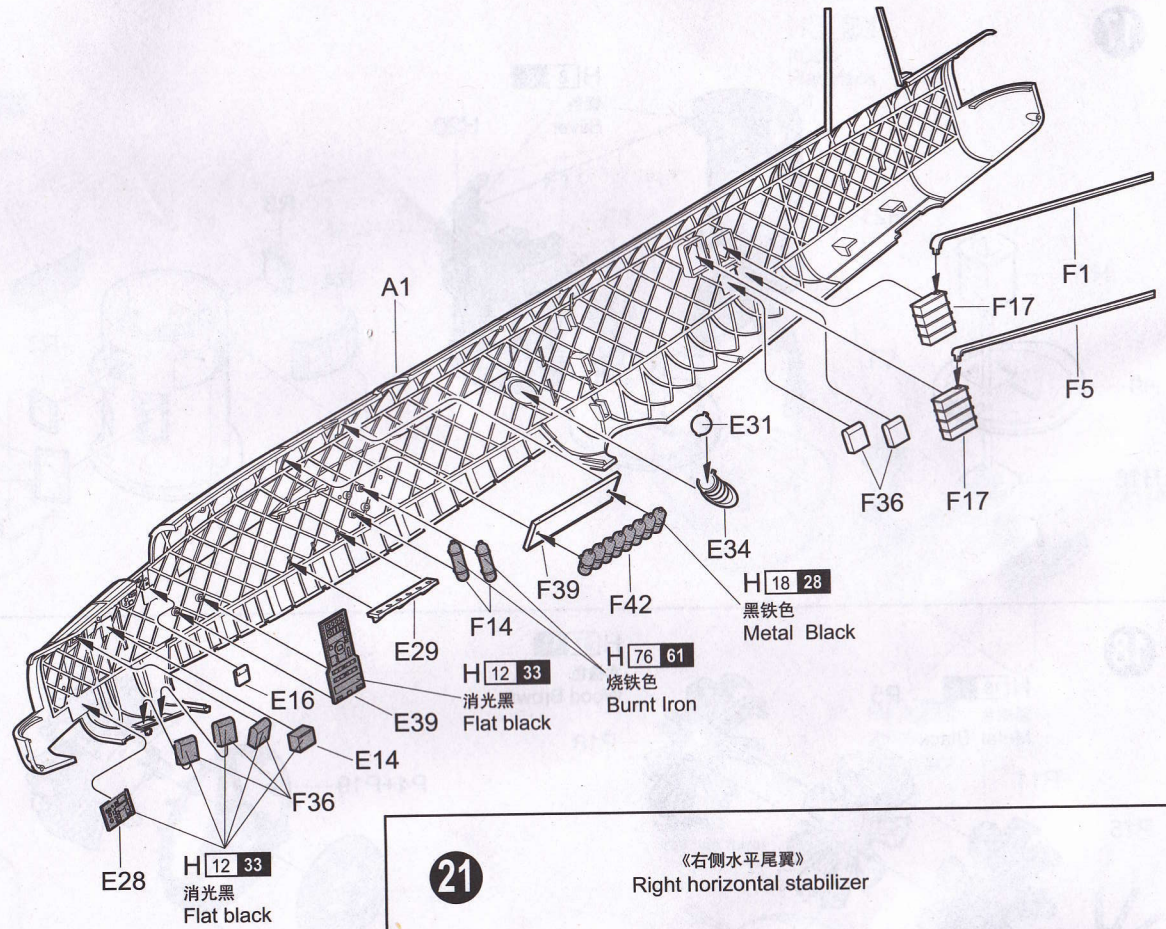
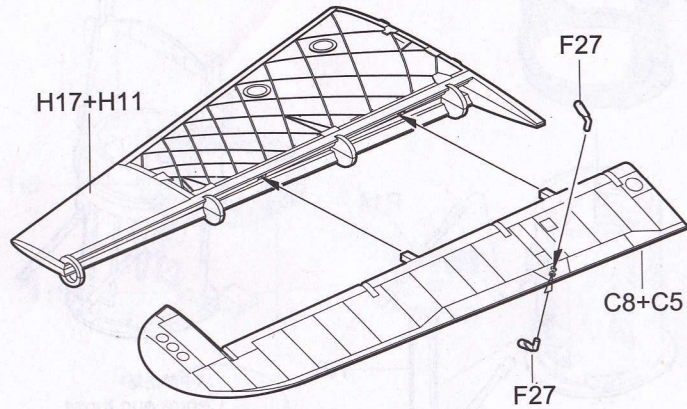

20

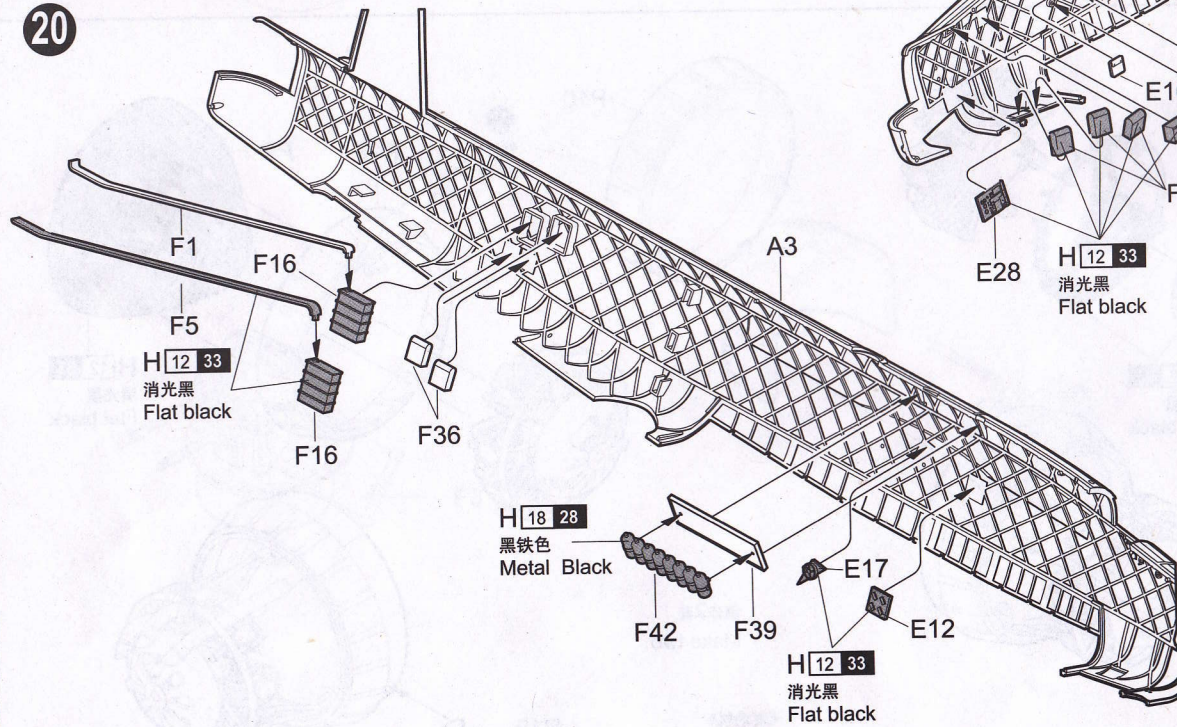

21

《右侧水平尾翼》
Right horizontal stabilizer

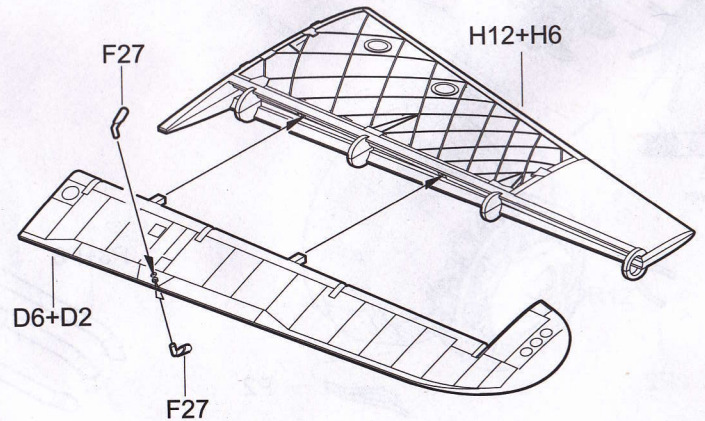

22

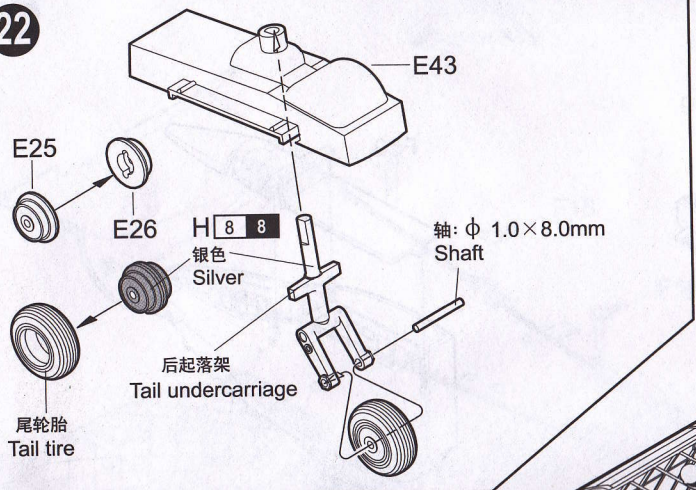

23

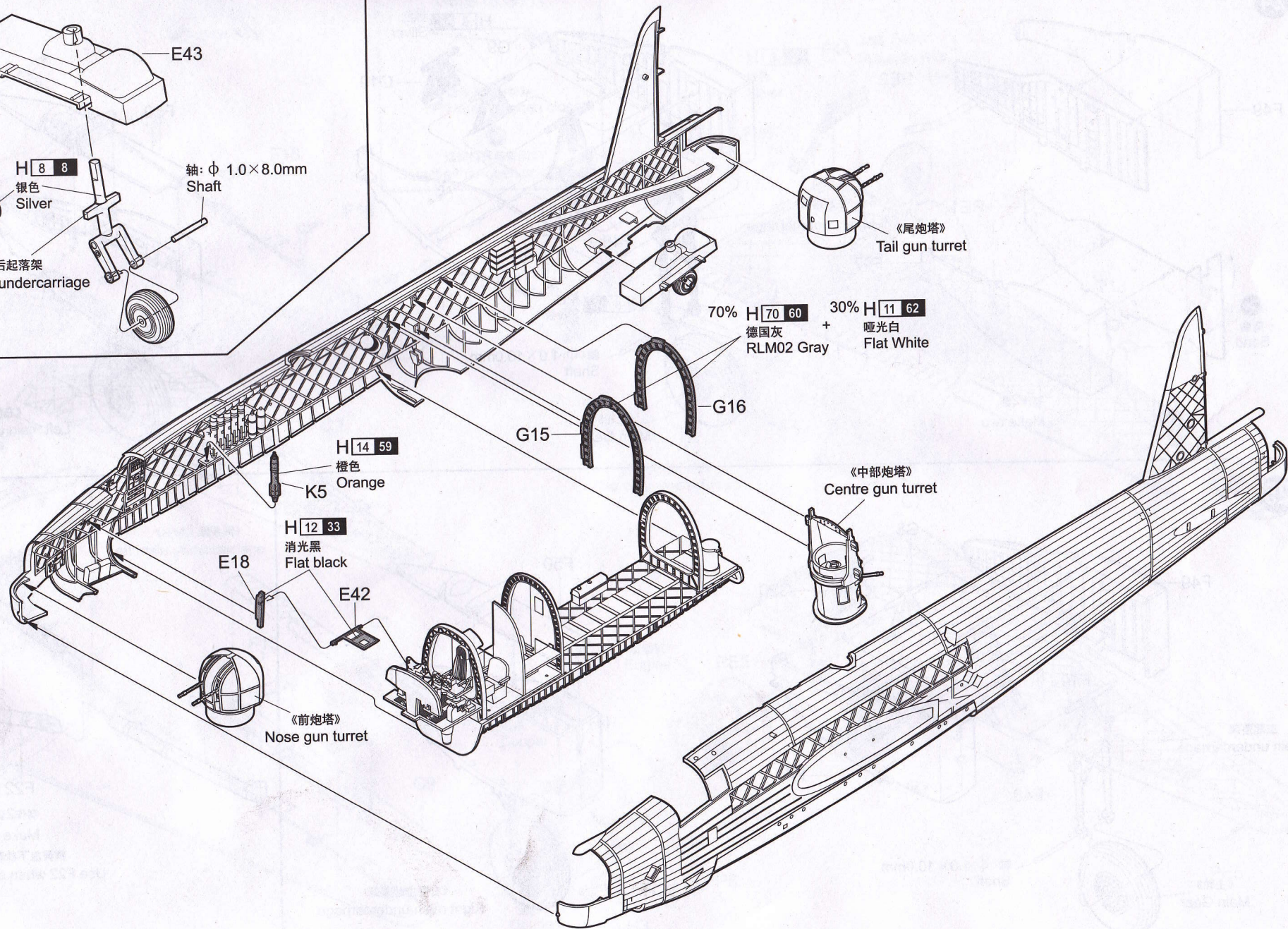

24

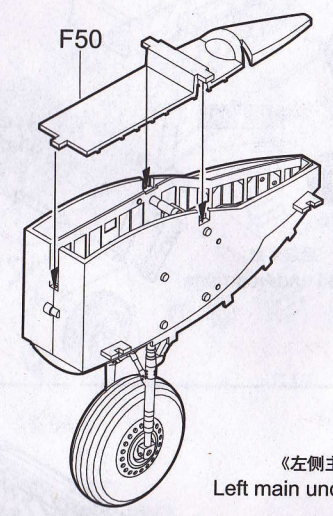
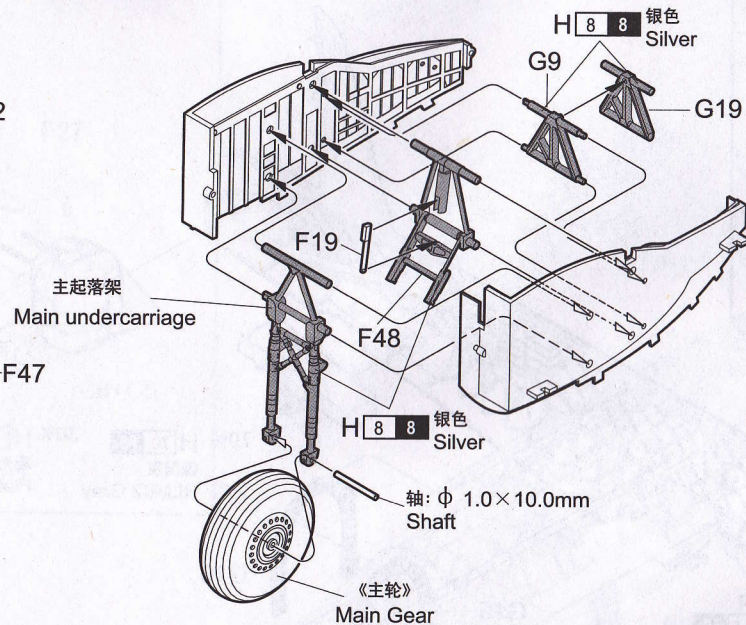
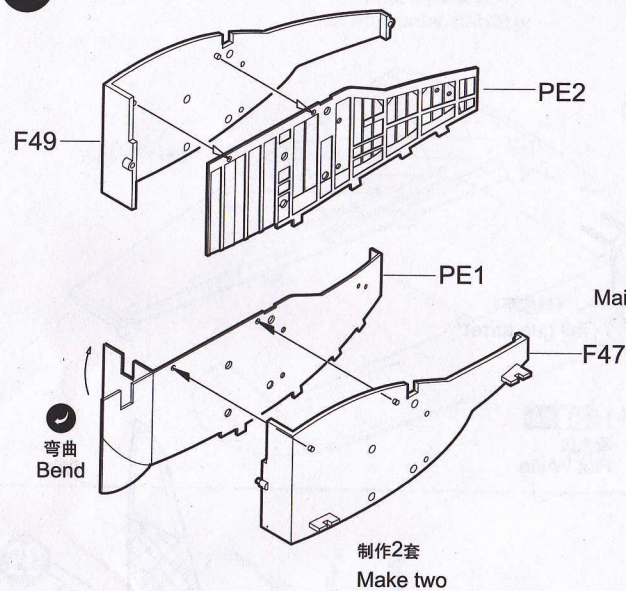

25

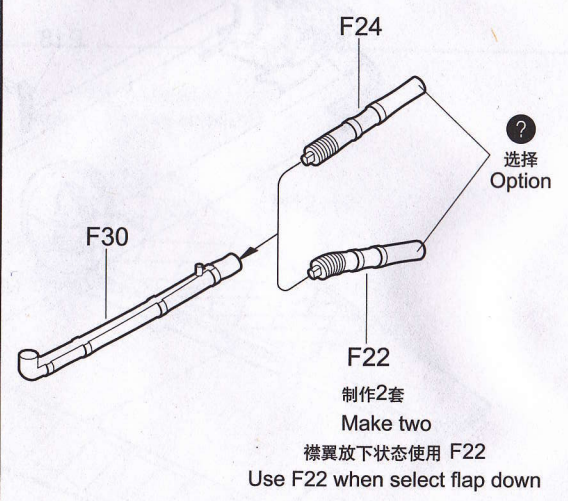
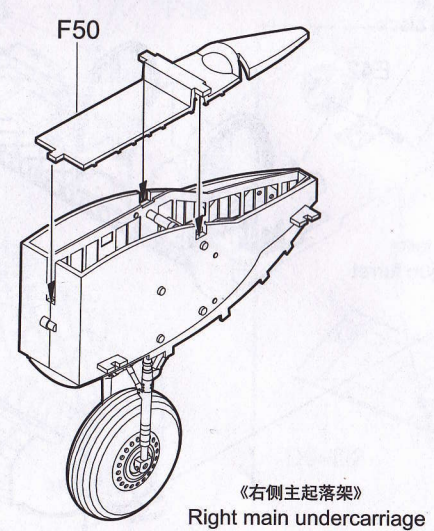
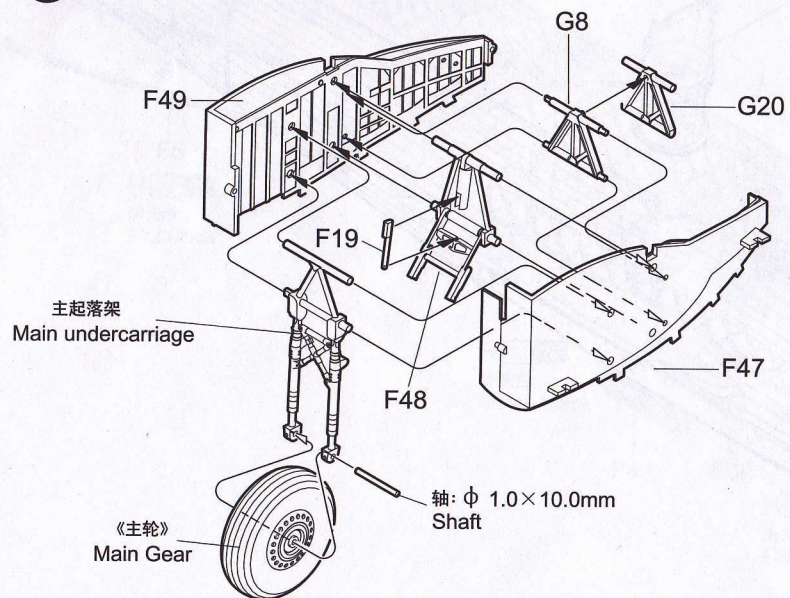

26

《左侧机翼》
Left main wing

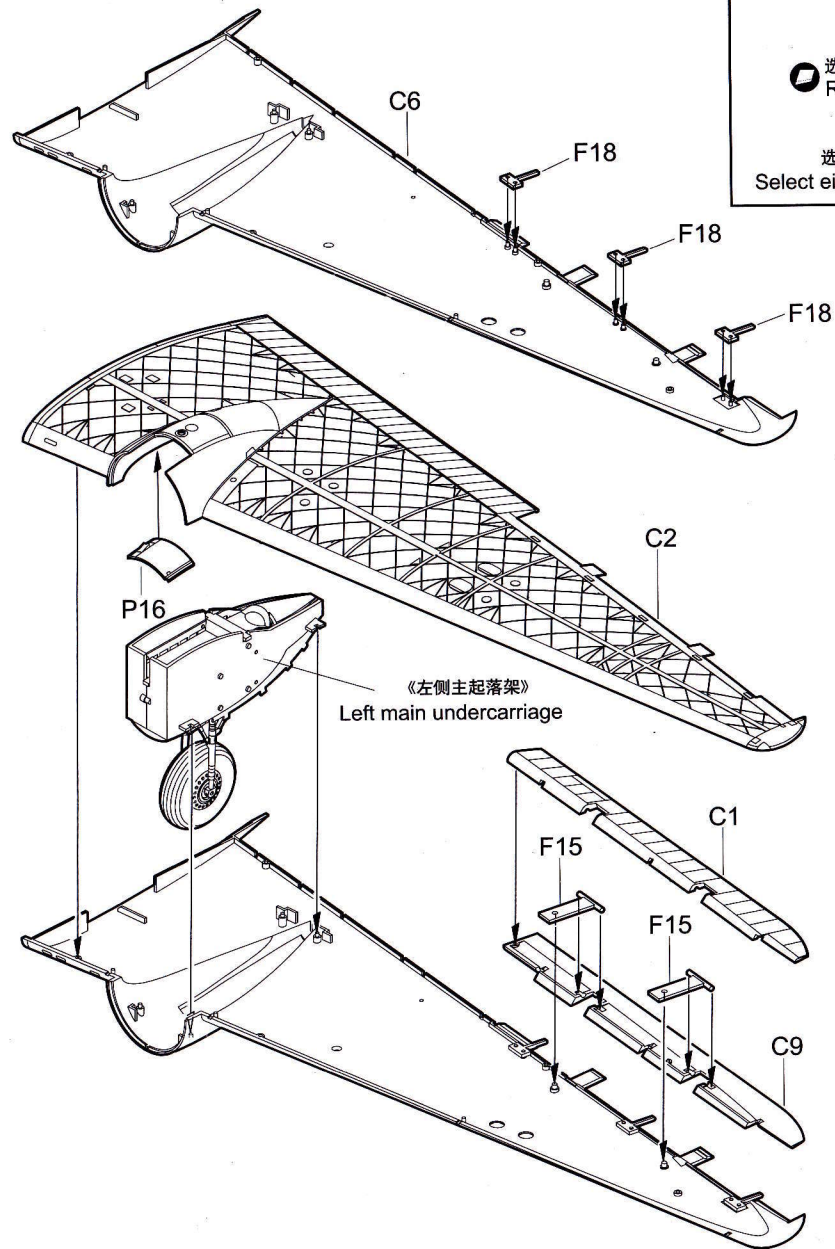

G6(G10,G11)



● 选择关闭时切除
Remove when closed

● 选择打开与关闭
Select either open or closed

● 选择
Option

选择关闭时安装
Use only when closed

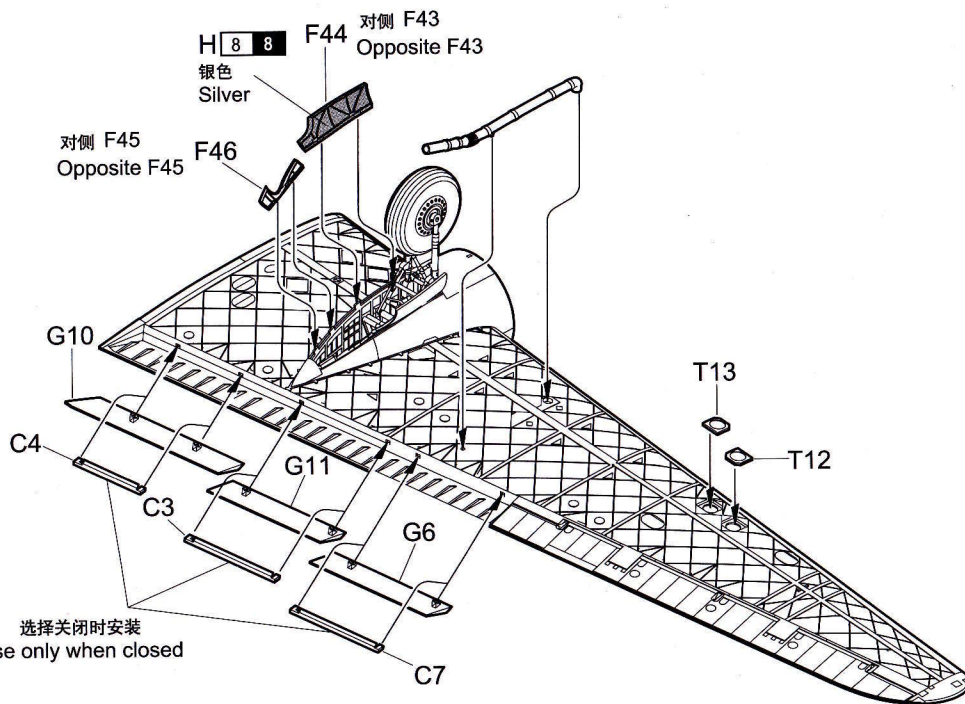

H 10 10
铜色
Copper

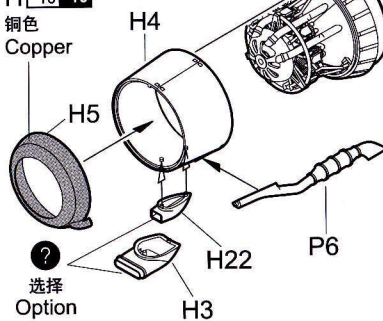

《发动机》
Engine

● 选择
Option

27

《右侧机翼》
Right main wing

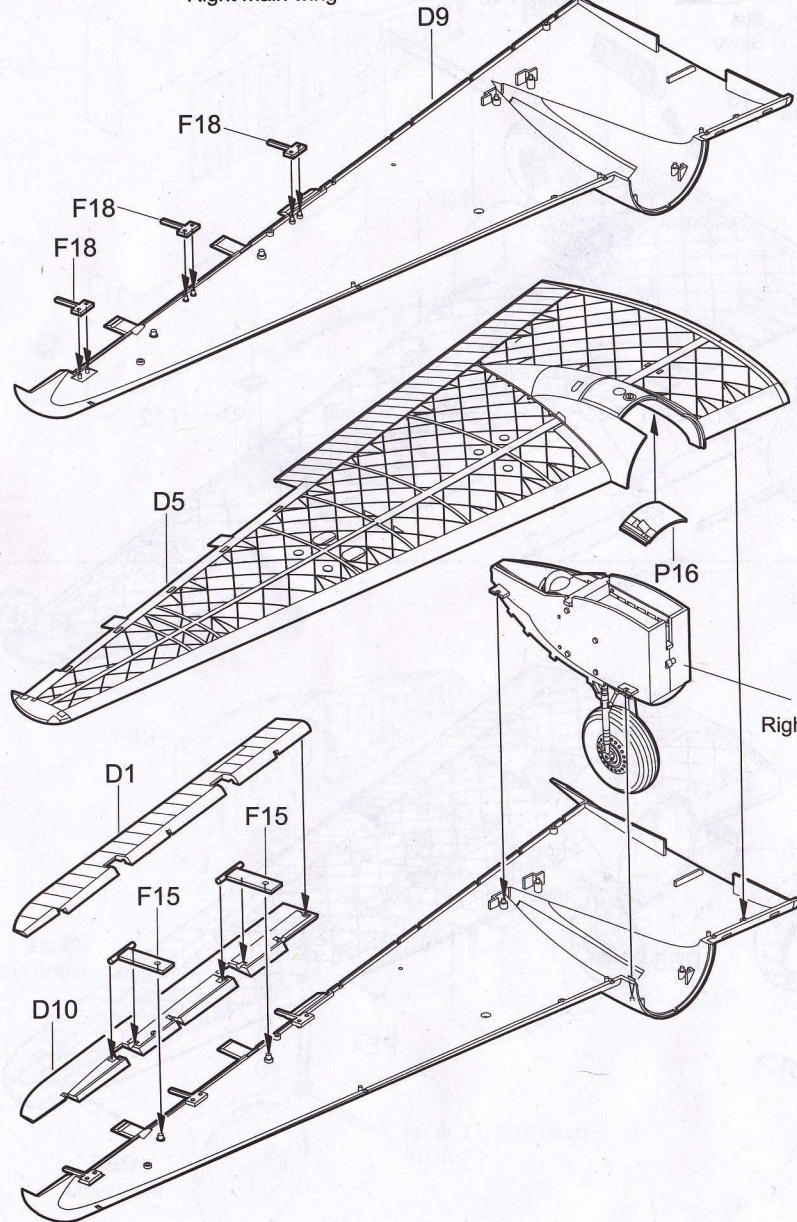

G4(G5,G7)



选择关闭时切除
Remove when closed

选择打开与关闭
Select either open or closed

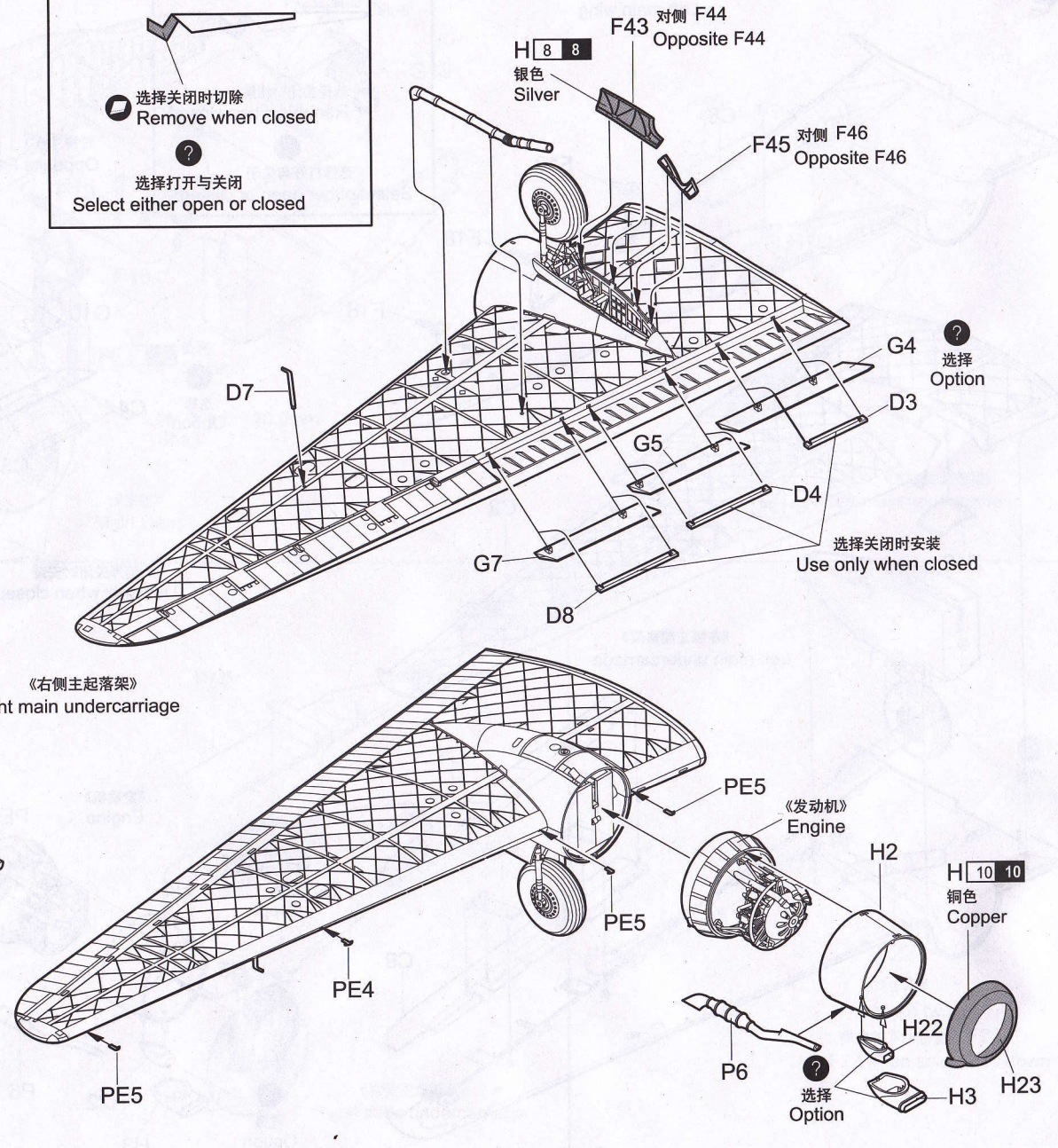

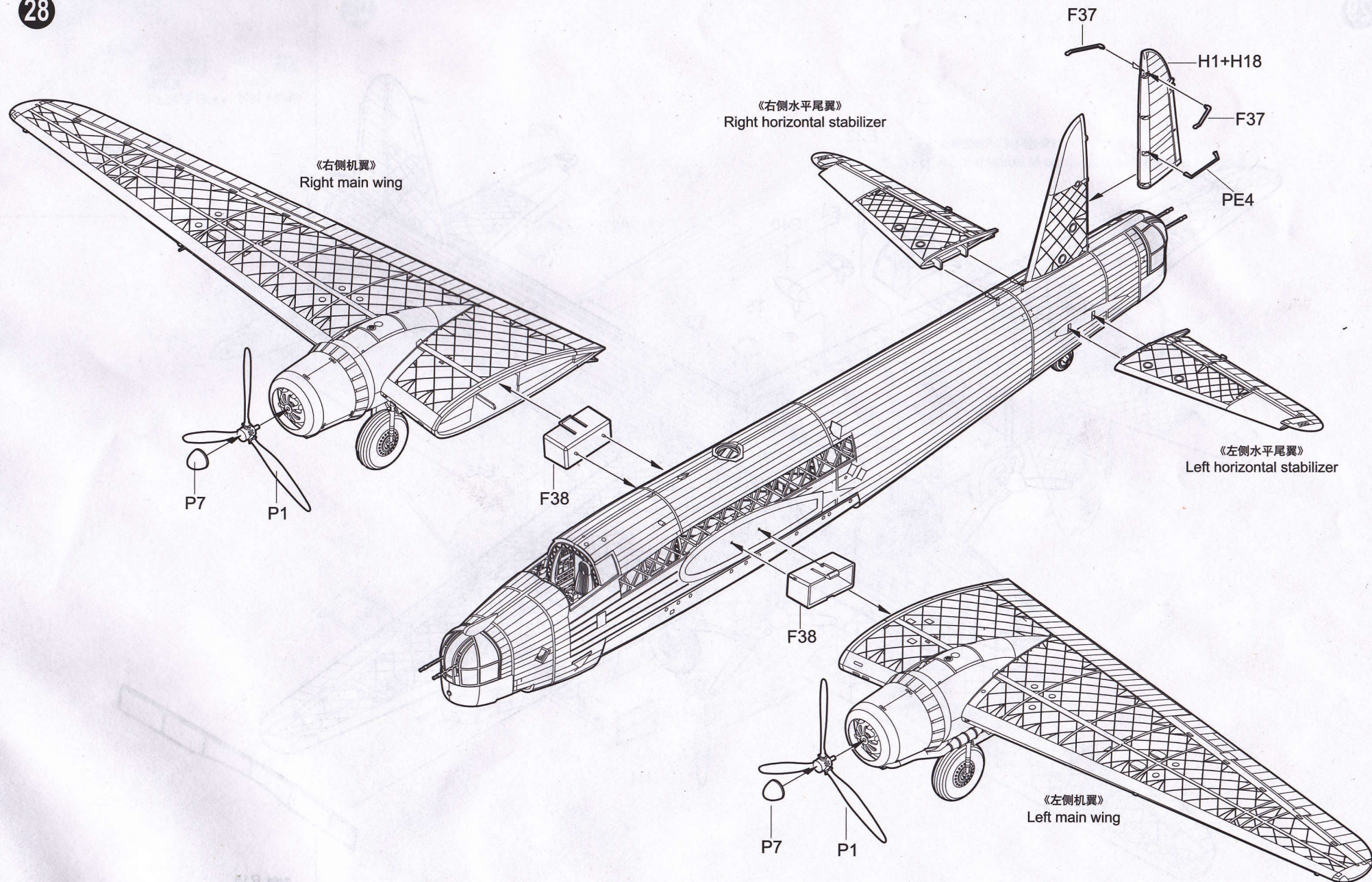

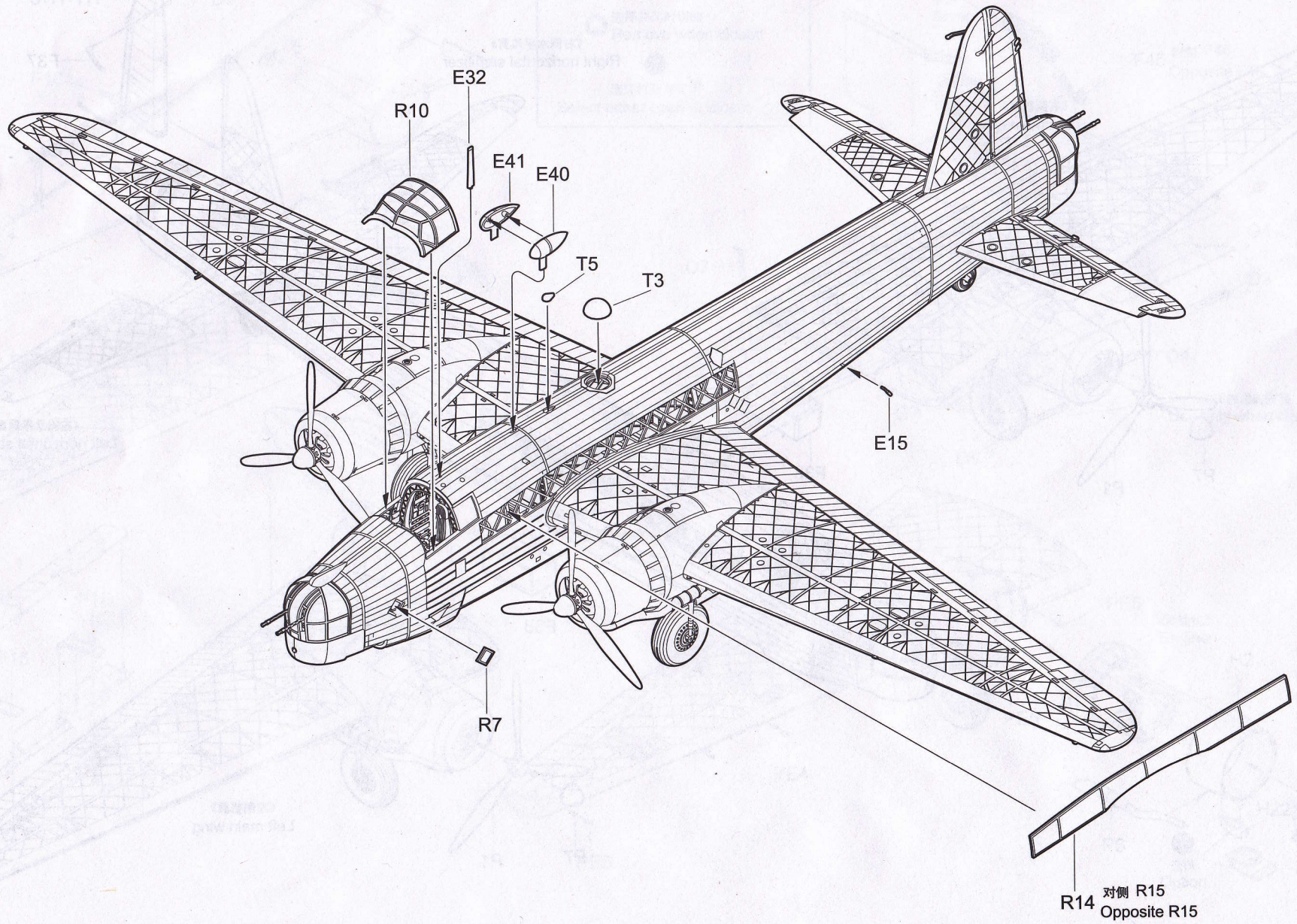

30

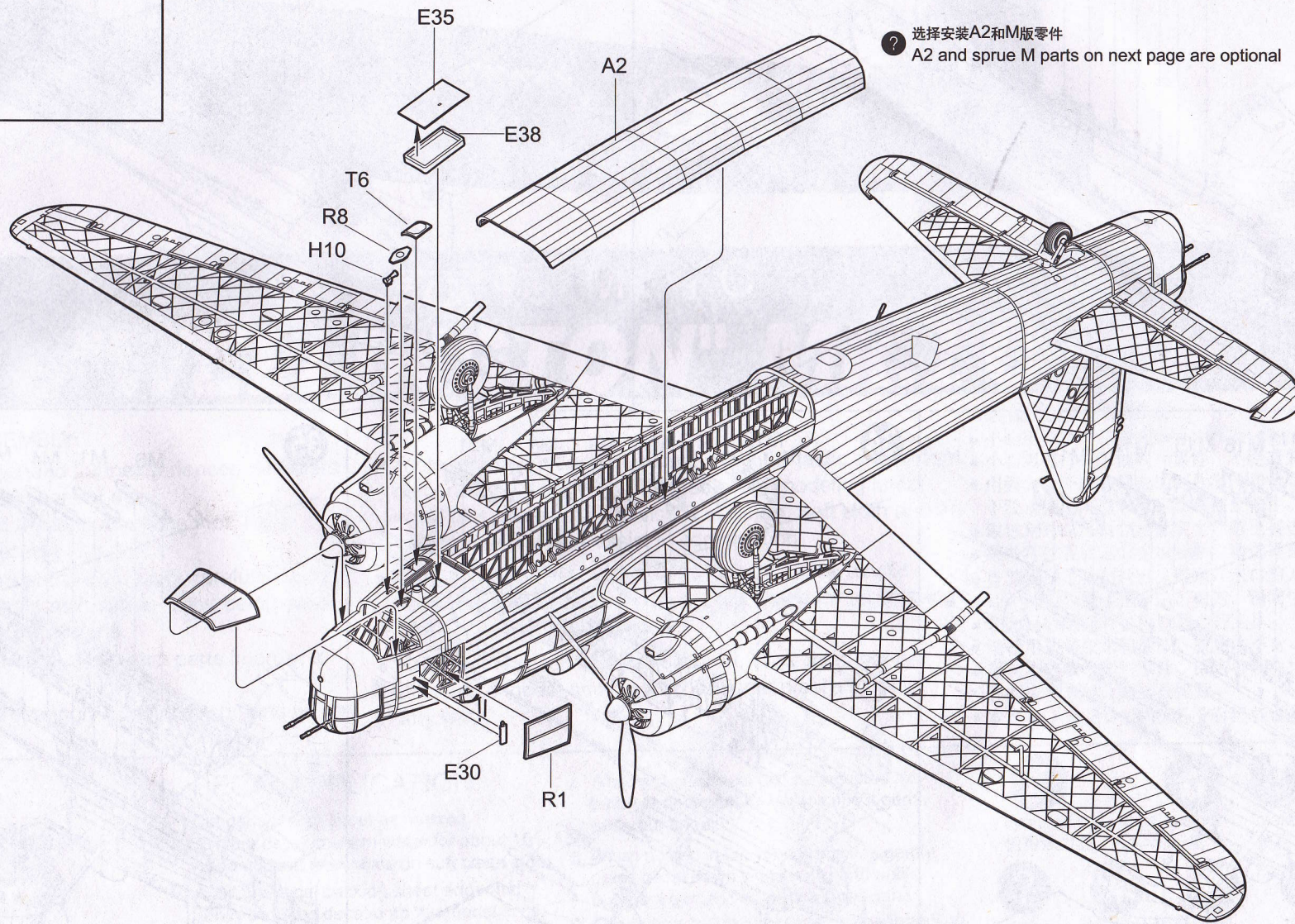
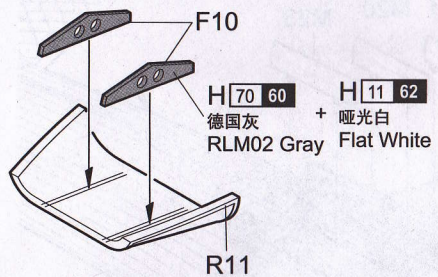

? 选择安装A2和M版零件
A2 and sprue M parts on next page are optional

H 12 33
黑色(哑光)
FLAT BLACK

H 93 50
透明蓝
CLEAR BLUE

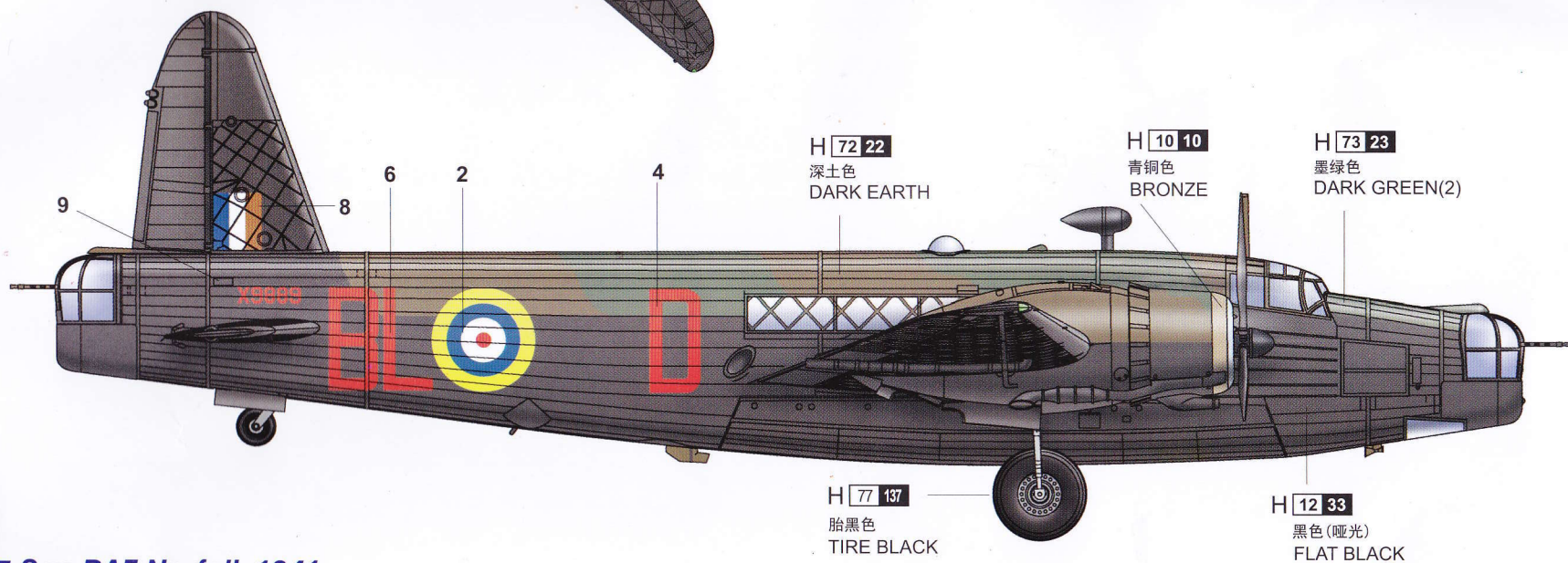

B
No.75 Sqn RAF Norfolk 1941

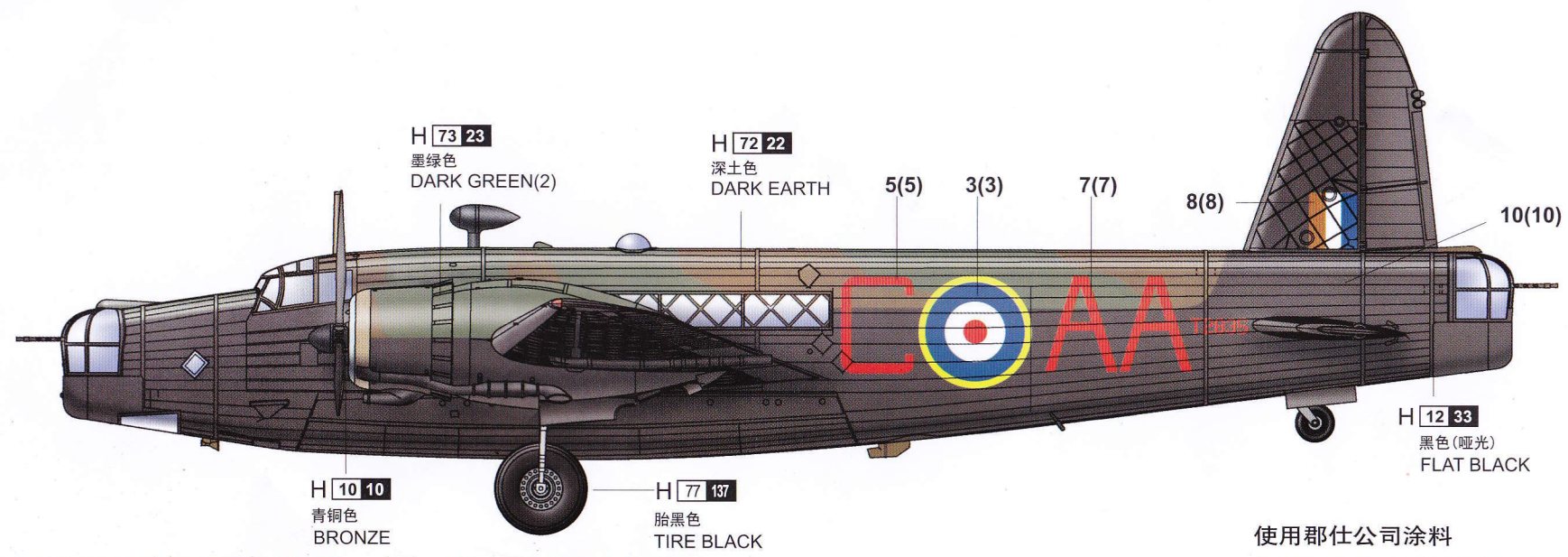

H 8 GUNZE SANGYO AQVEOUS HOBBY COLOUR 8 GUNZE SANGYO MR.COLOUR

使用郡仕公司涂料
GUNZE SANGYO Mr. Color used

涂装同标贴指示
Painting & Marking guide

A

No.40 Sqn RAF Malta 1941

