

P-47D THUNDERBOLT "DORSAL FIN"

1:32 SCALE

P-47D 雷电“背鳍型”战斗机

READ BEFORE ASSEMBLY:

- This kit is not recommended for inexperienced modelers or for children under 14 years of age
- Study and understand these instructions thoroughly before beginning assembly
- When needed, remove photo-etch parts carefully using a modeling knife or photo etch sprue cutter, being careful not to damage or lose small parts.
- Take extra care in handling photo etch parts in order to avoid injury
- Apply instant cement sparingly to photo etch parts where instructed

- Tools recommended(not included in kit):Plastic and instant cements,sprue cutters,long nose pliers,modeling knife, small files, tweezers, pin vise & scissors. Soft cloth and sandpaper will also assist in construction
- Glue and paint are not included in the kit. Use plastic cement and hobby paints only. Color guide for purchasing paint is included in the kit.
- Keep out of reach of children. They must not be allowed to ingest small parts or handle plastic bags in any way.

装配之前仔细阅读

- 小心用模型锉刀锉平所有零件表面的注射浇口。
- 小心用刀片切下蚀刻片零件，不要遗失小零件。
- 用强力快干胶水粘合蚀刻片零件和金属轴。过量的快干胶水使用可能导致可动零件会粘住，小心涂胶。
- 取蚀刻片时应特别注意安全，防止利边划伤手指。
- 某些零件表面需贴水上贴纸，请选择在装配的同时进行。
- 推荐模型工具(自备)：胶水，水口剪刀，长咀钳，刀片，锉刀，镊子钳，钻，剪刀，瞬间快干胶。
- 软布同砂纸同时也应该是必备工具。
- 请使用塑料胶水和油漆，模型内不含。
- 谨防小孩吮吸塑料零件，或者将塑料袋套在头上，制作时应将套材远离小孩接触。
- 本产品不适合14岁以下没有经验的模型爱好者。

水贴纸的使用:

1. 从水贴上剪下印花;
2. 将印花放入温水中浸10秒, 然后放在干净布上.
3. 拿着印花纸板将印花移到模型上;
4. 手指蘸水将印花移到适当的位置;
5. 用软布轻压印花直至水干, 汽泡消失.

DECAL APPLICATION:

1. Cut decals from sheet as needed
2. Dip the decal in warm water for about 10 seconds and then place on soft clean cloth.
3. Hold the decal backing sheet edge and gently slide the decal onto the model in its proper position.

4. While still wet,decal can be adjusted for better fit on model by dampening it gently with your finger.
5. When placed in the proper position,gently press decal down with a soft cloth until excess water and air bubbles are gone.
6. Allow decal to dry completely before handling model



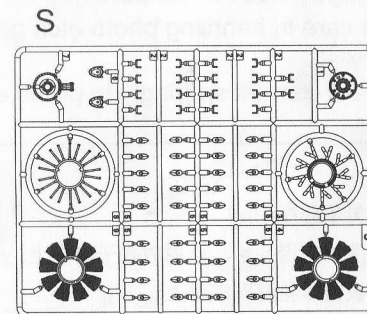
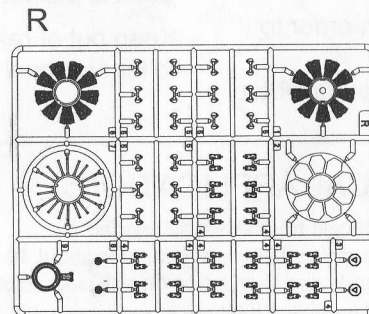
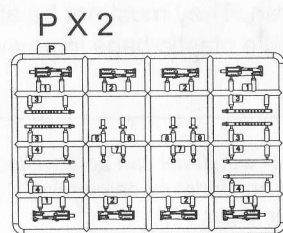
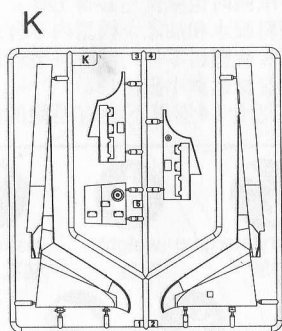
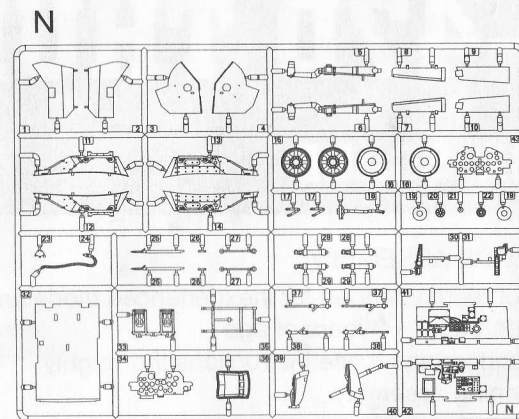
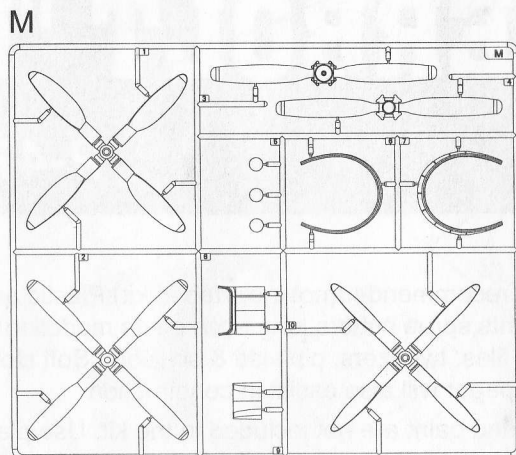
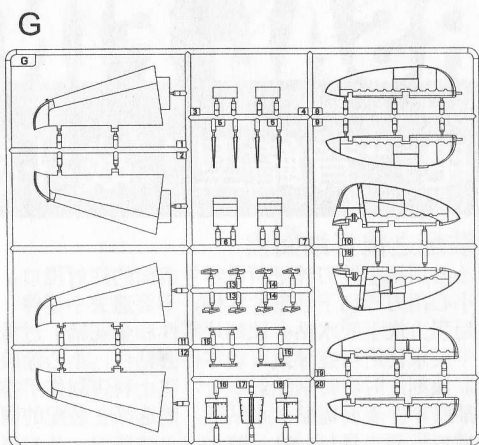
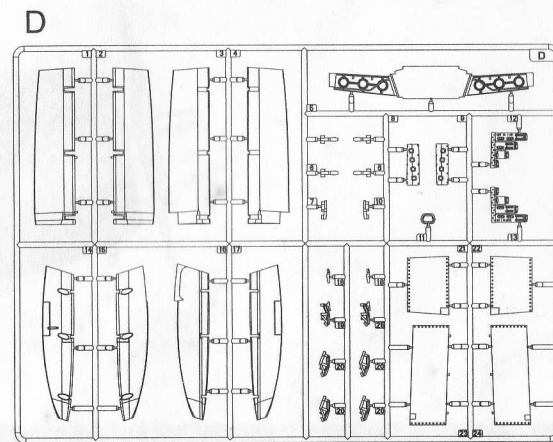
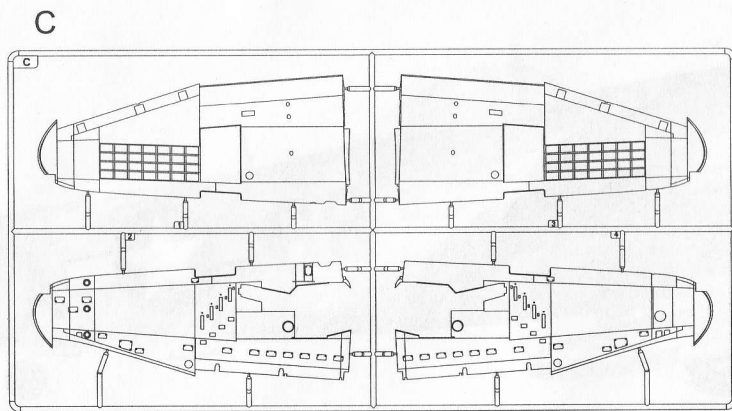
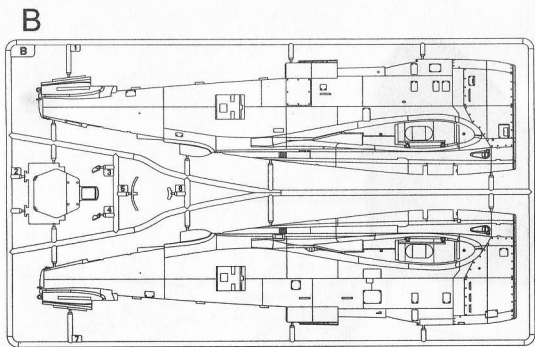

部品图

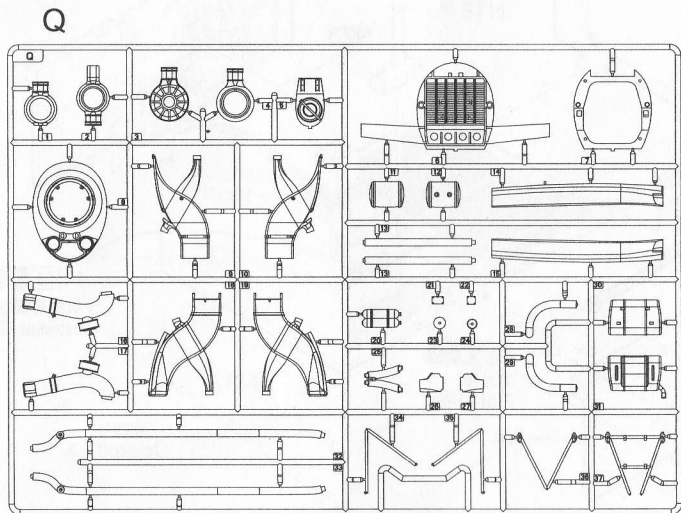

U×2

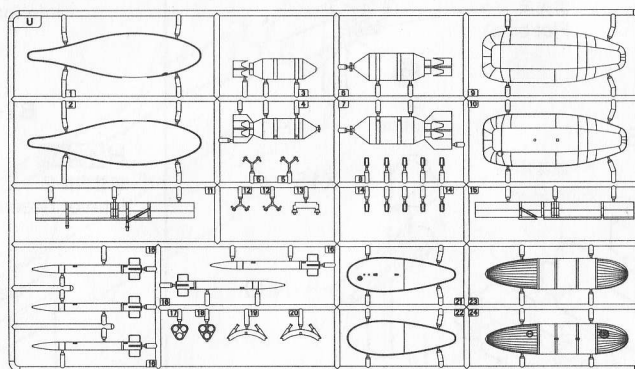

T

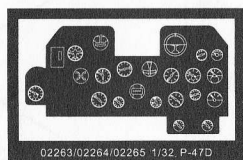
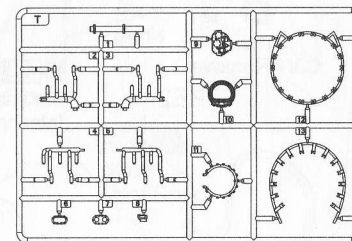

<<蚀刻片>>
Photo etched parts(PE)

<<菲林片>>
Film Part

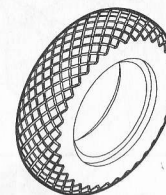
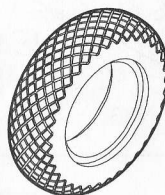

<<主轮胎>>
Main tyre



<<尾轮>>
Tail tyre

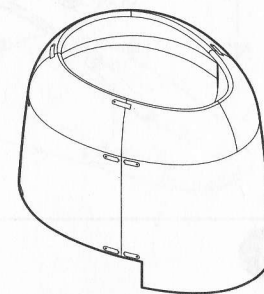

<<引擎罩>>
Cowling

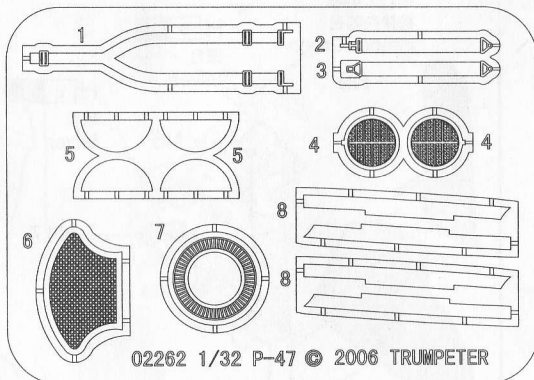
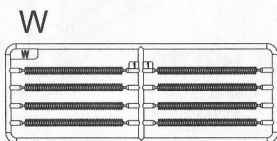
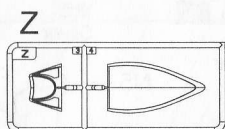
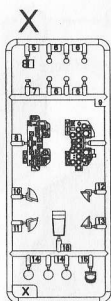

02262 1/32 P-47 © 2006 TRUMPETER

<<水贴 A>>
Decal A



<<水贴>>
Decal

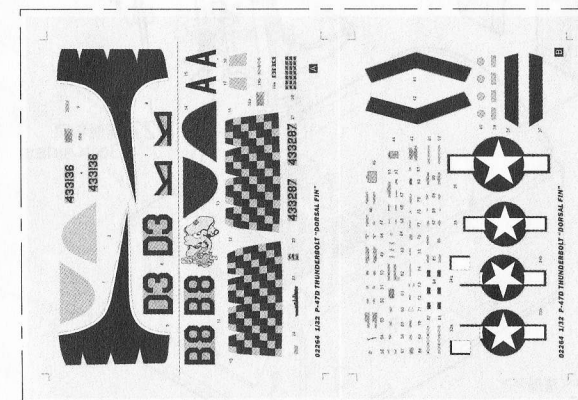

不用的部件: N43 U11 U15 U17 U18 X9 X10 X11 X16
unused parts

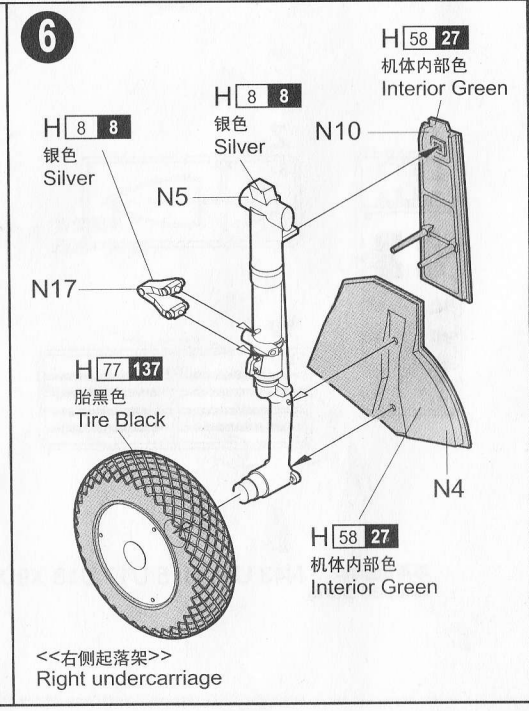
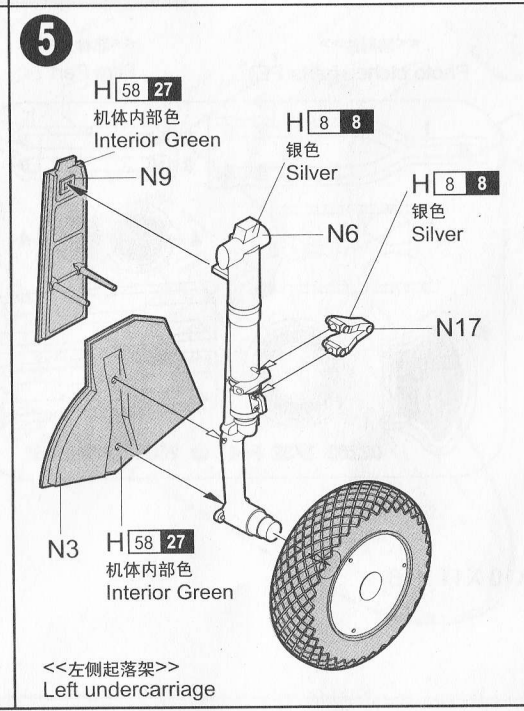
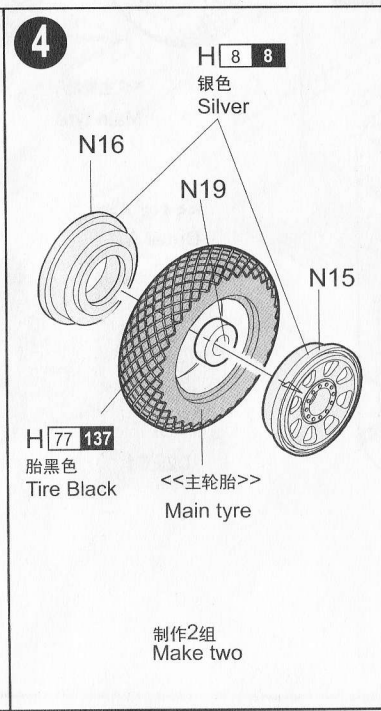
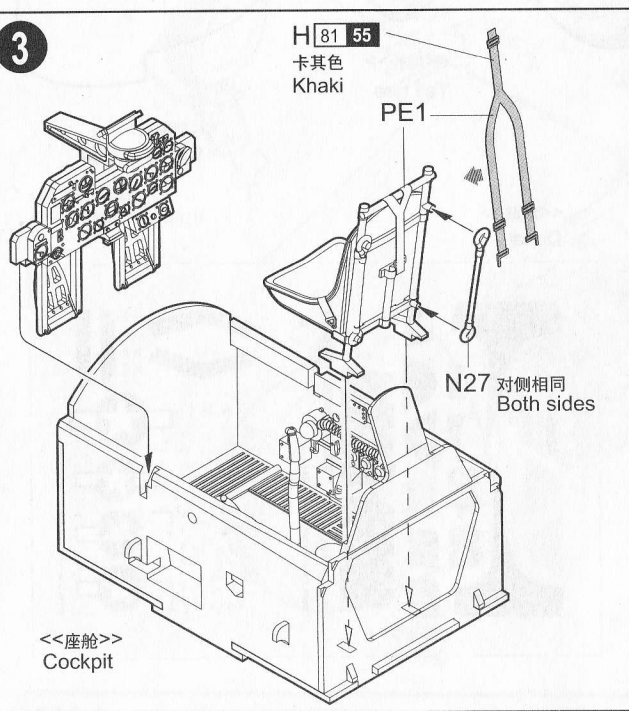
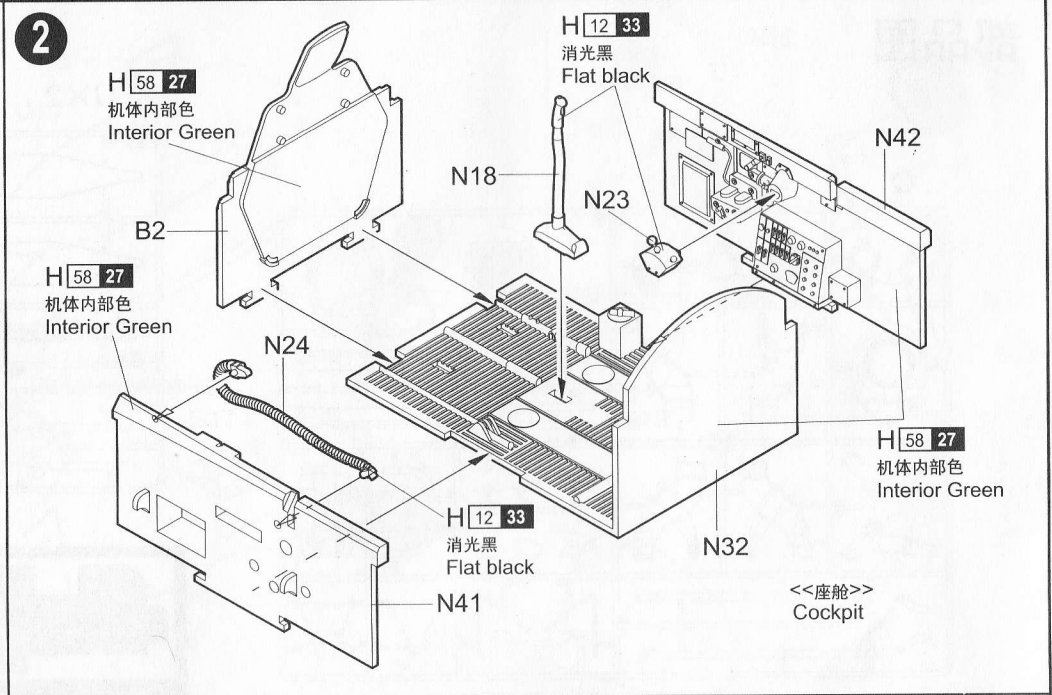
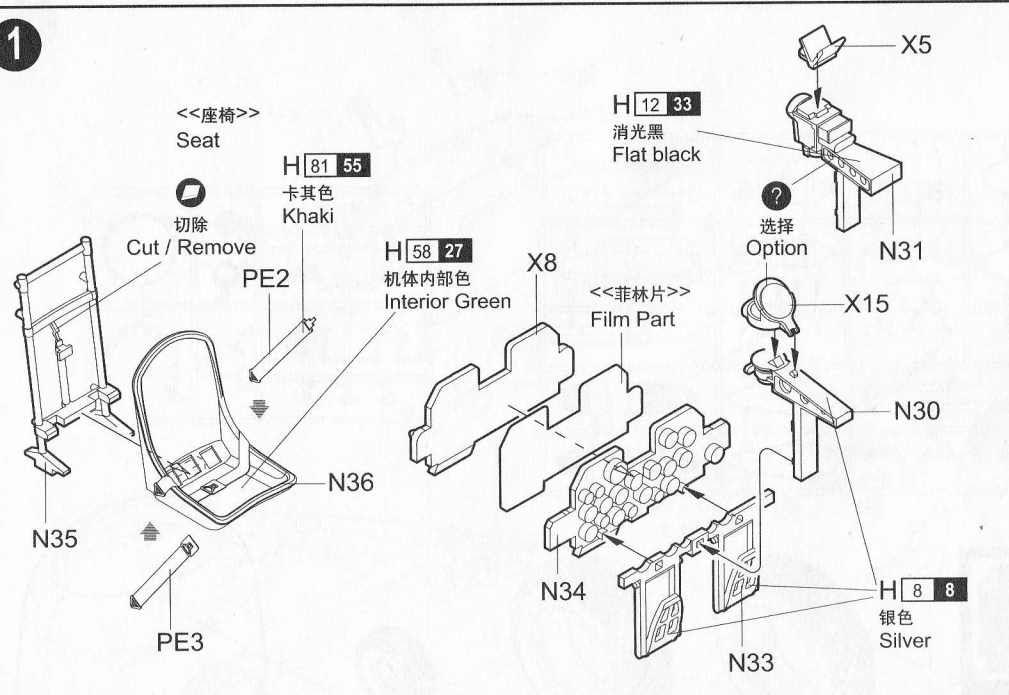

7

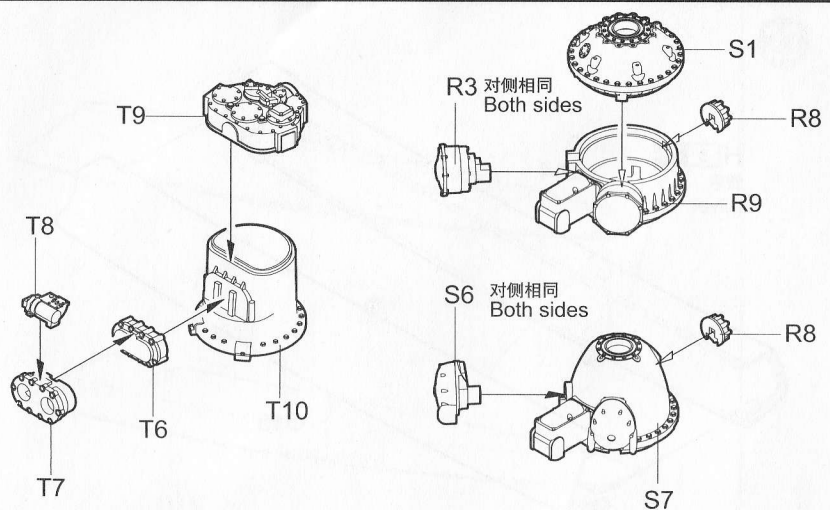

8

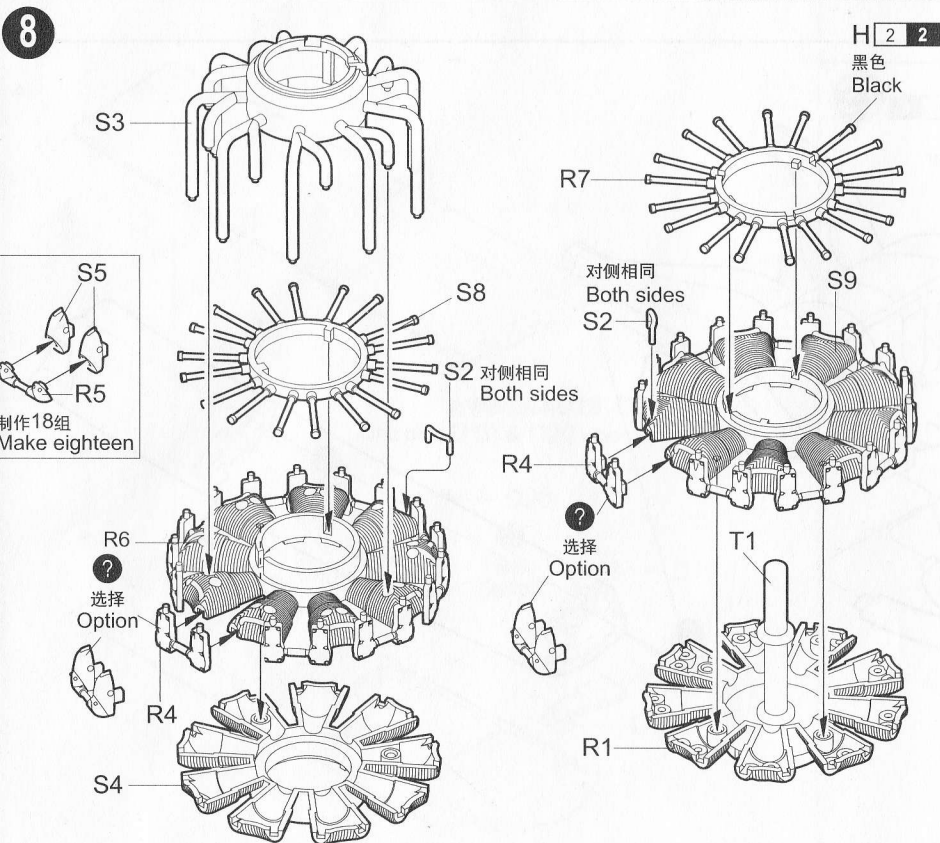

9

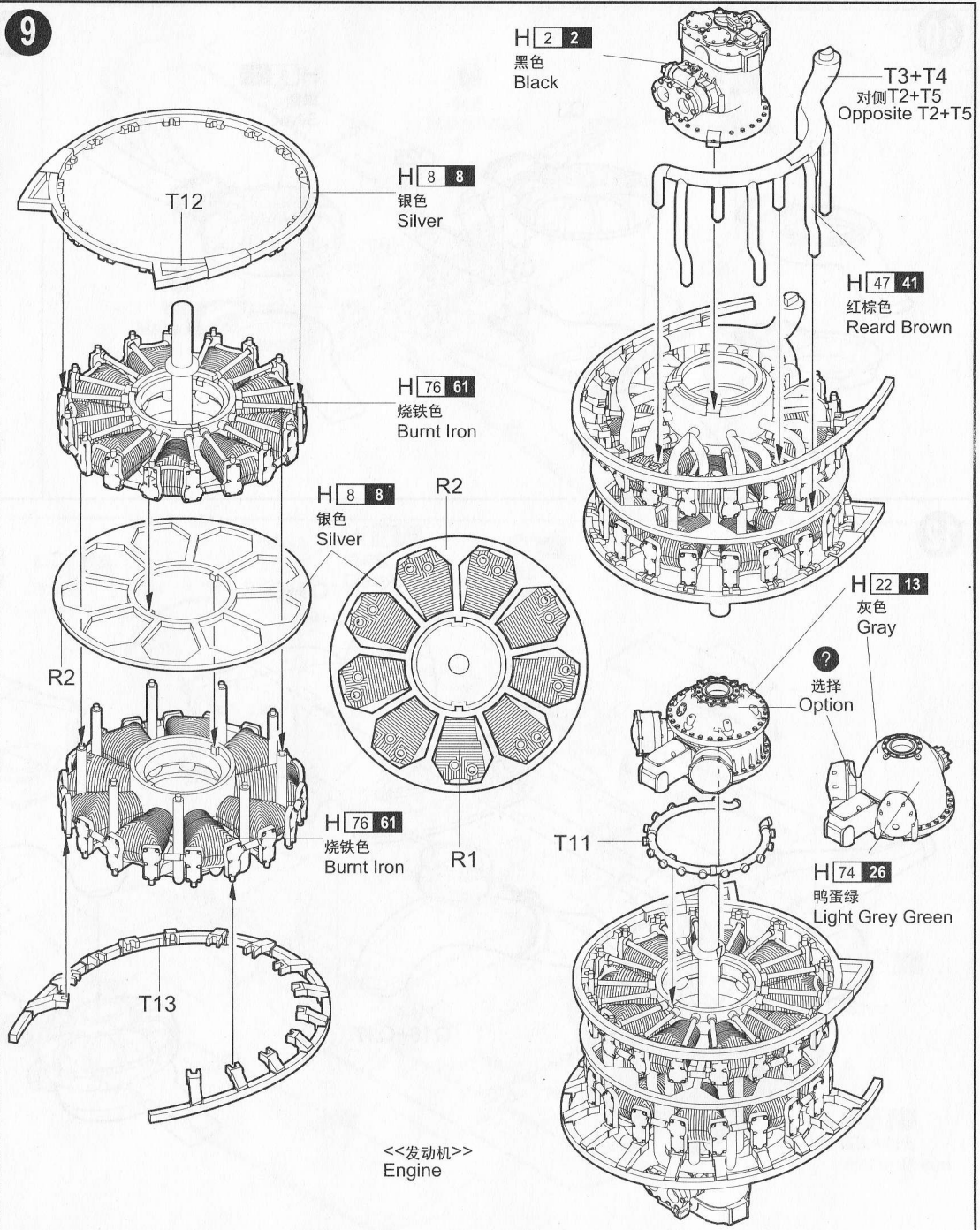

10

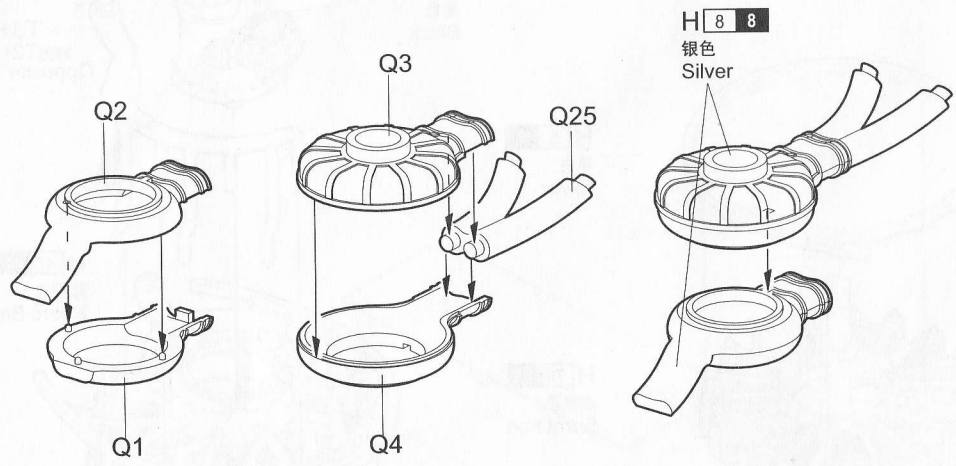

11

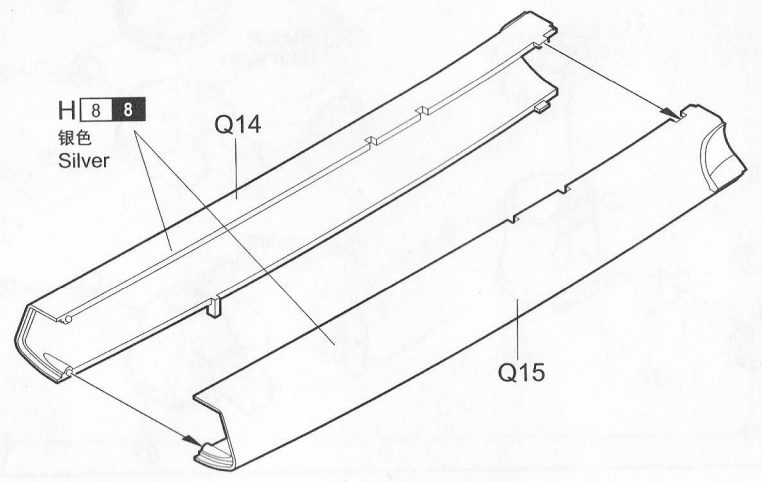

12

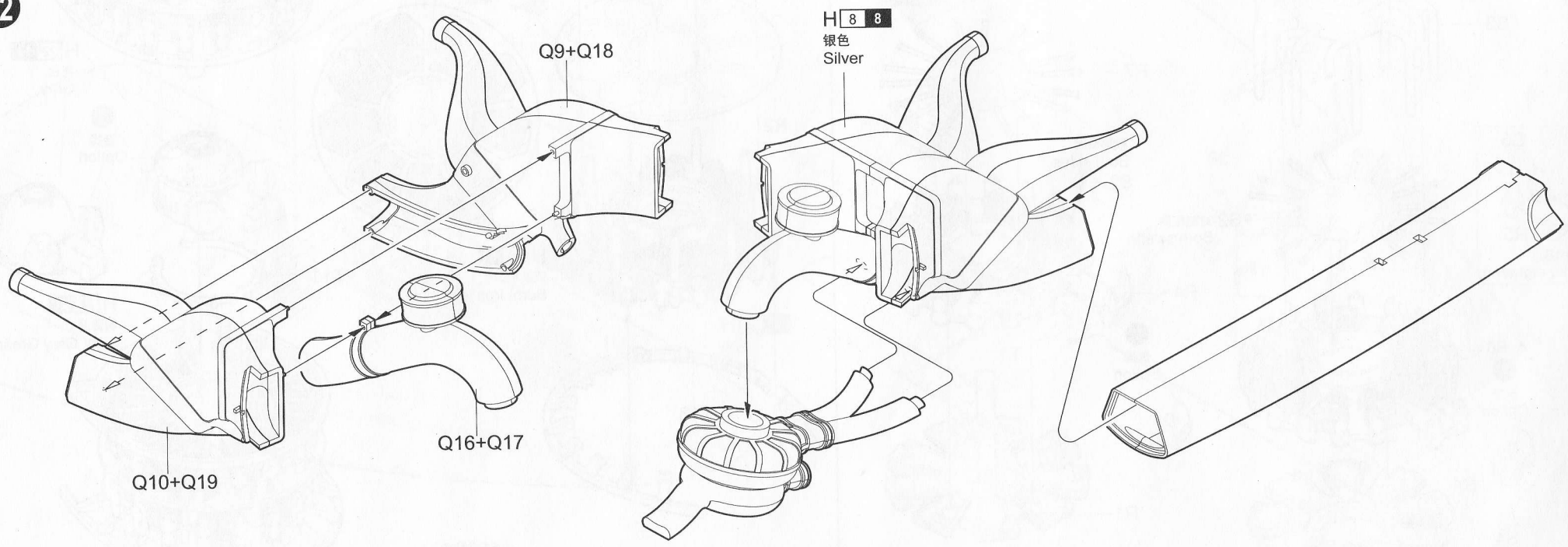

13

14

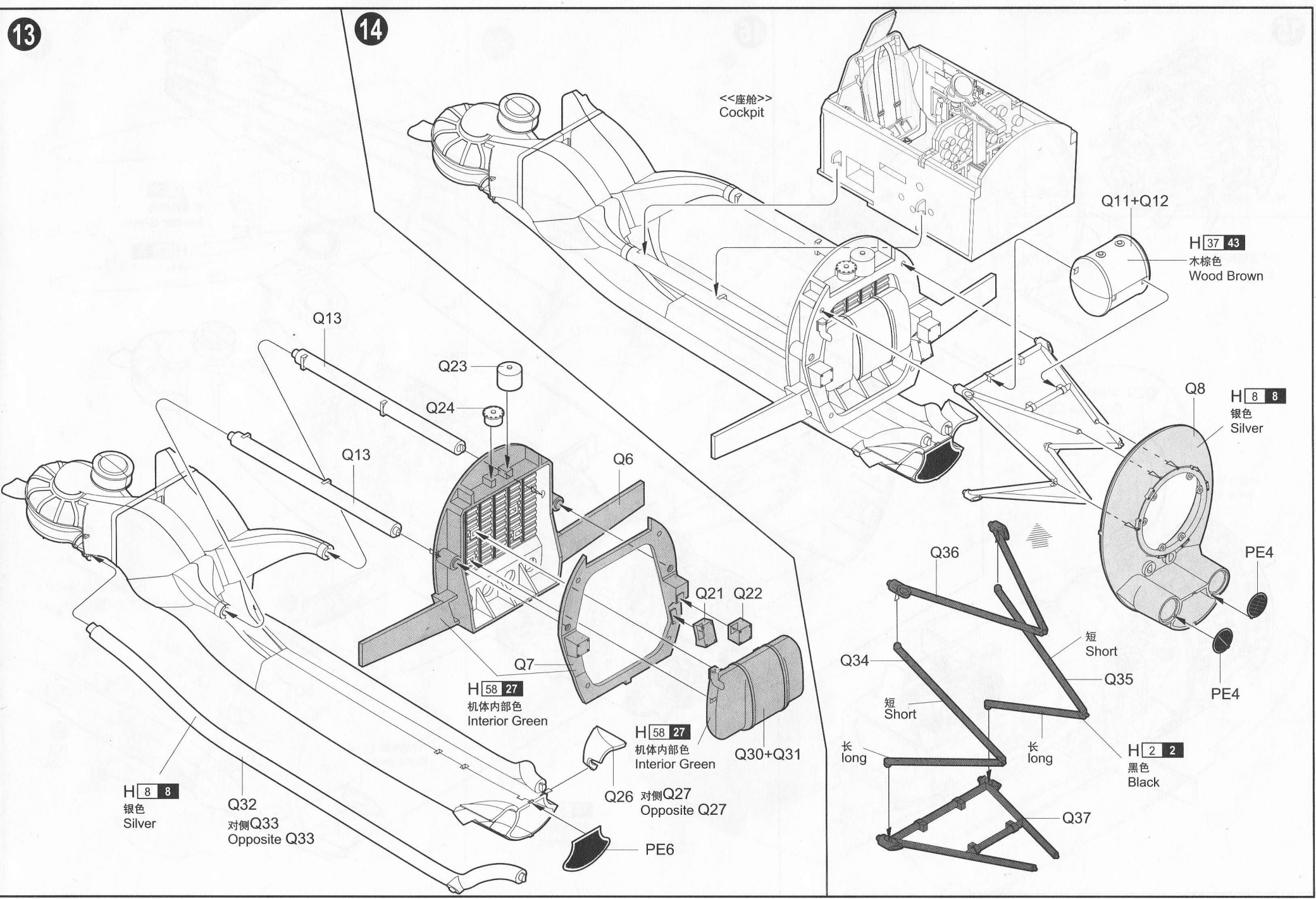

15

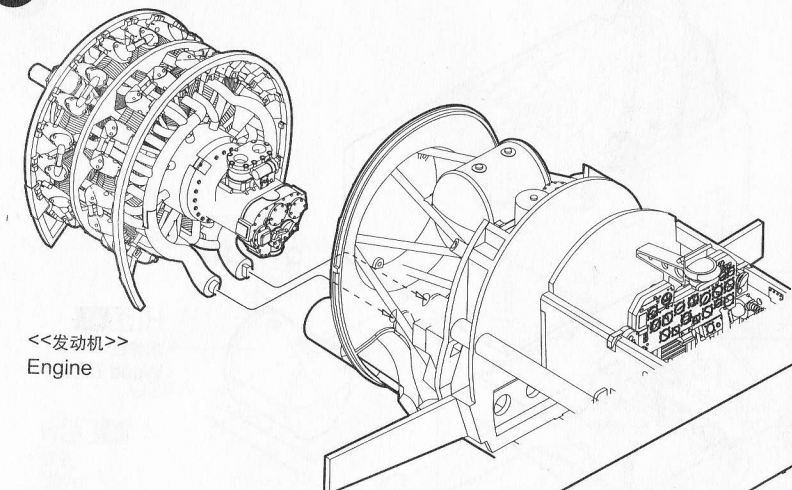

16

<<发动机>>
Engine

Q29 对侧 Q28
Opposite Q28

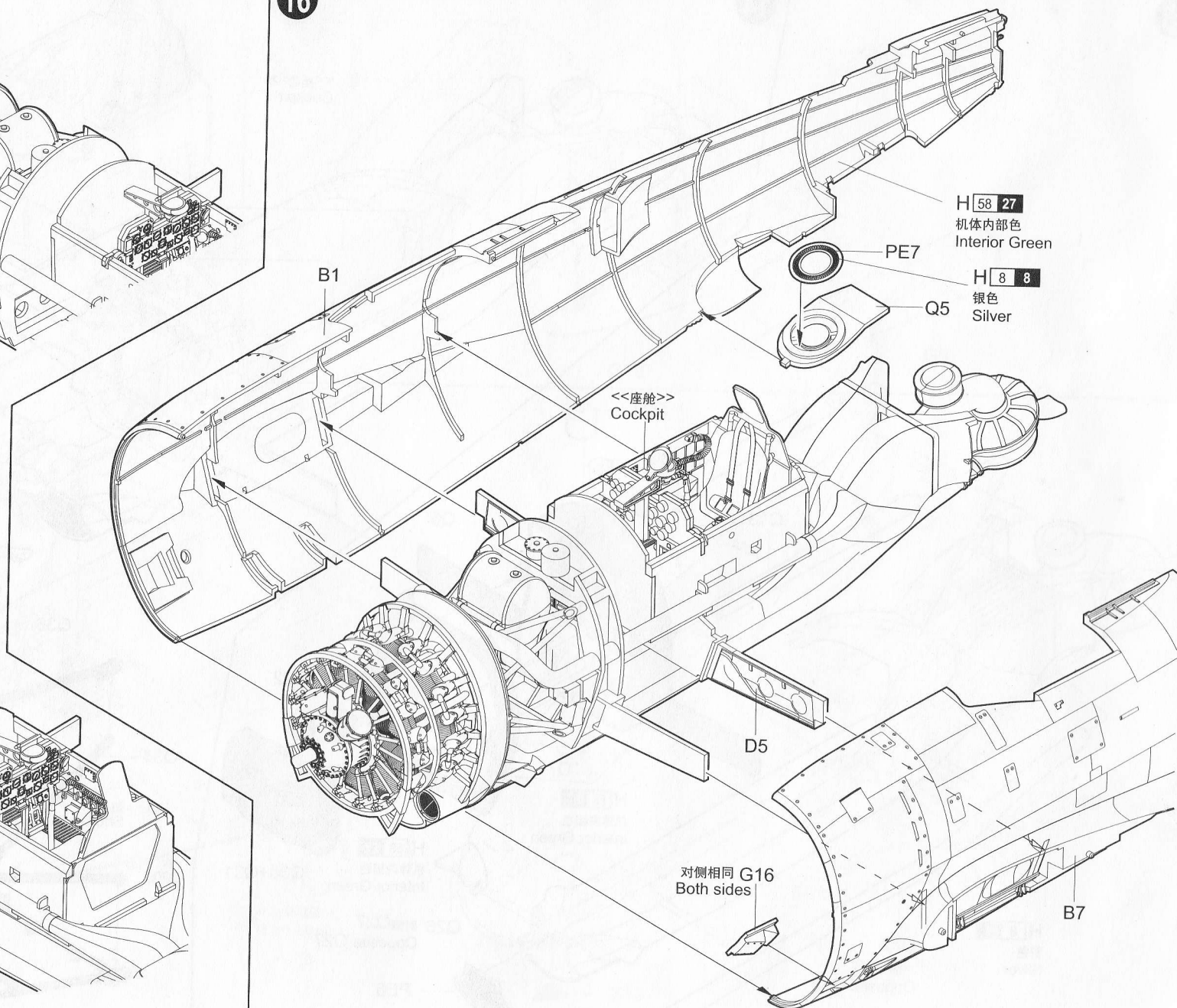
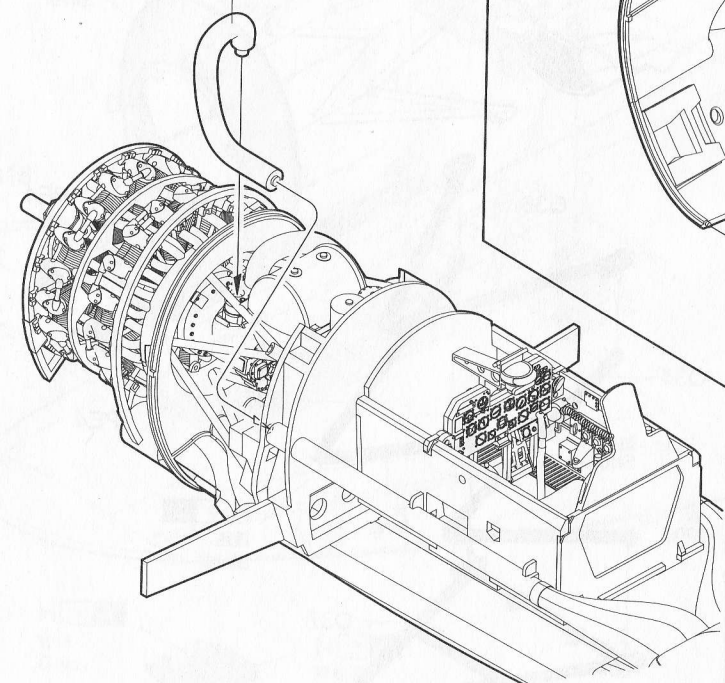

H 58 27
机体内部色
Interior Green

PE7

H 8 8
银色
Silver

Q5

<<座舱>>
Cockpit

B1

D5

对侧相同 G16
Both sides

B7

17

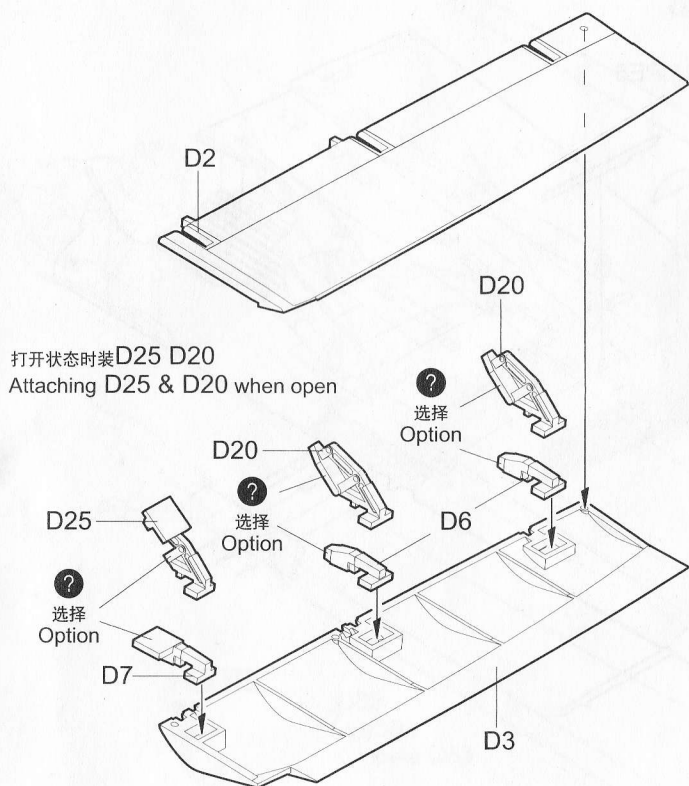
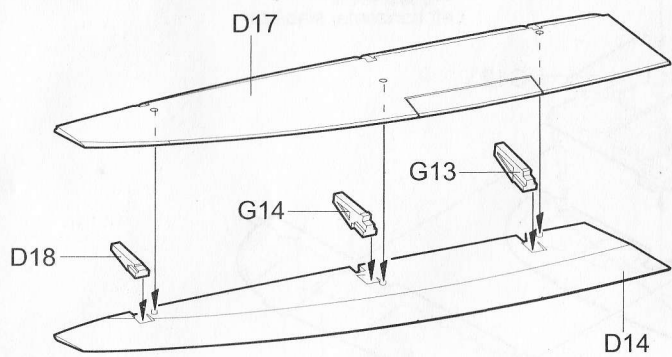

18

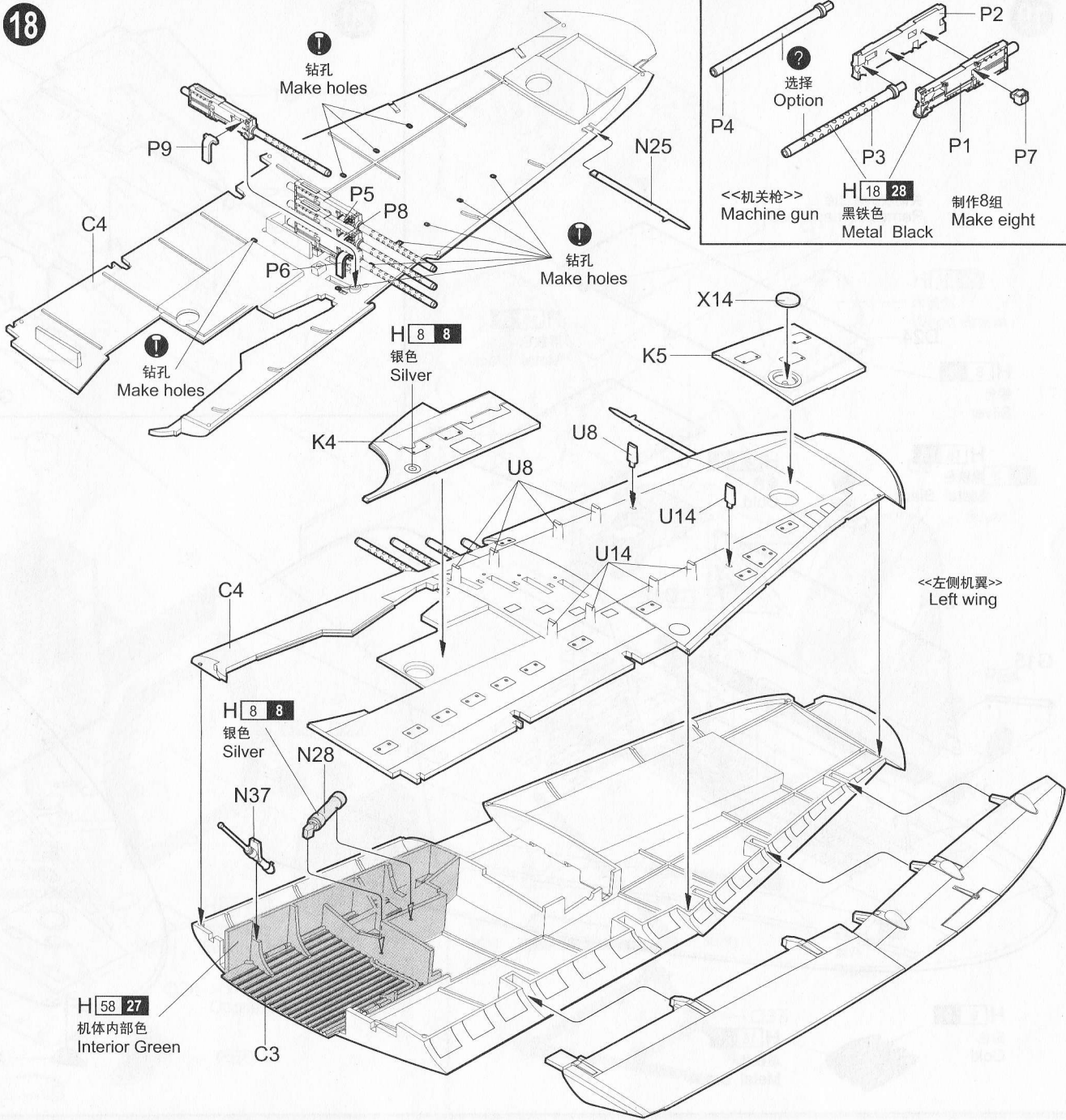

19

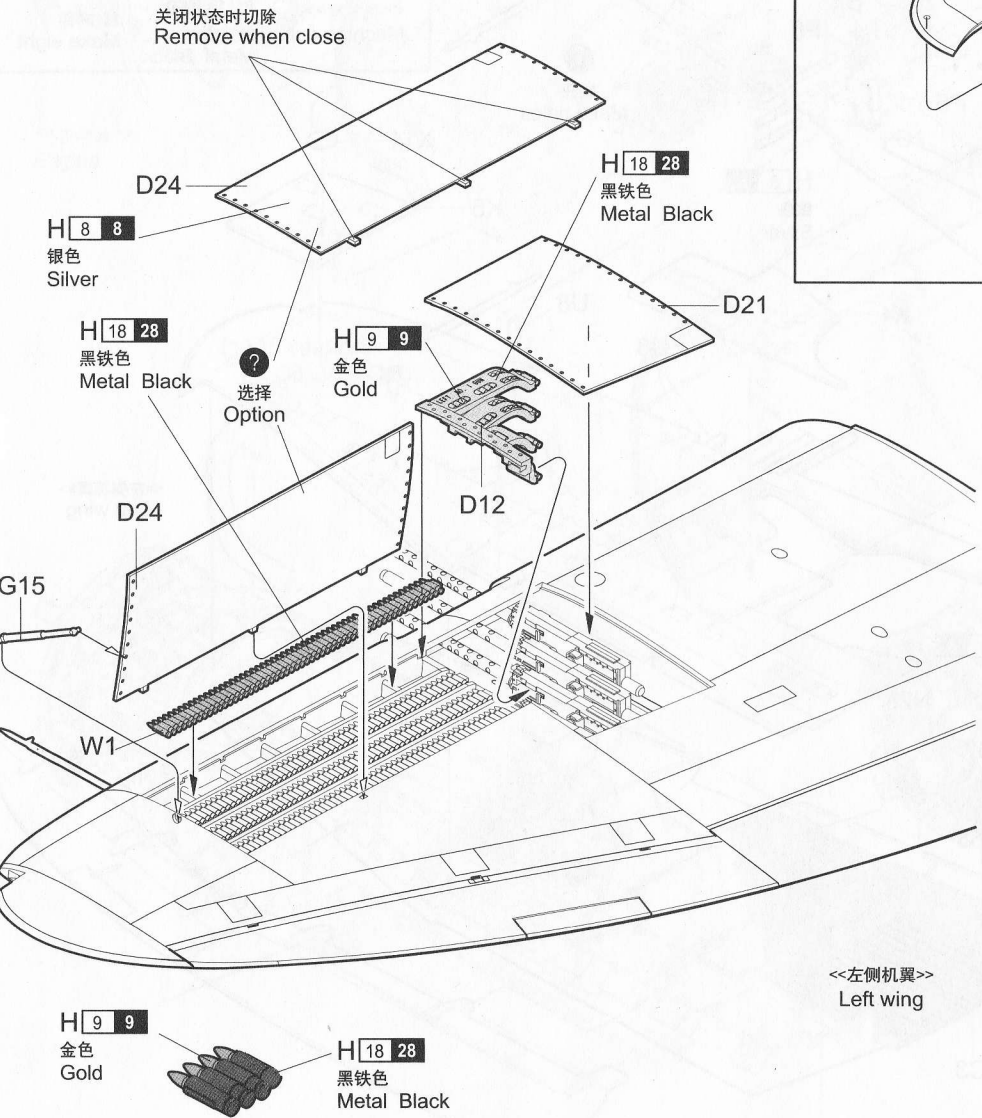

20

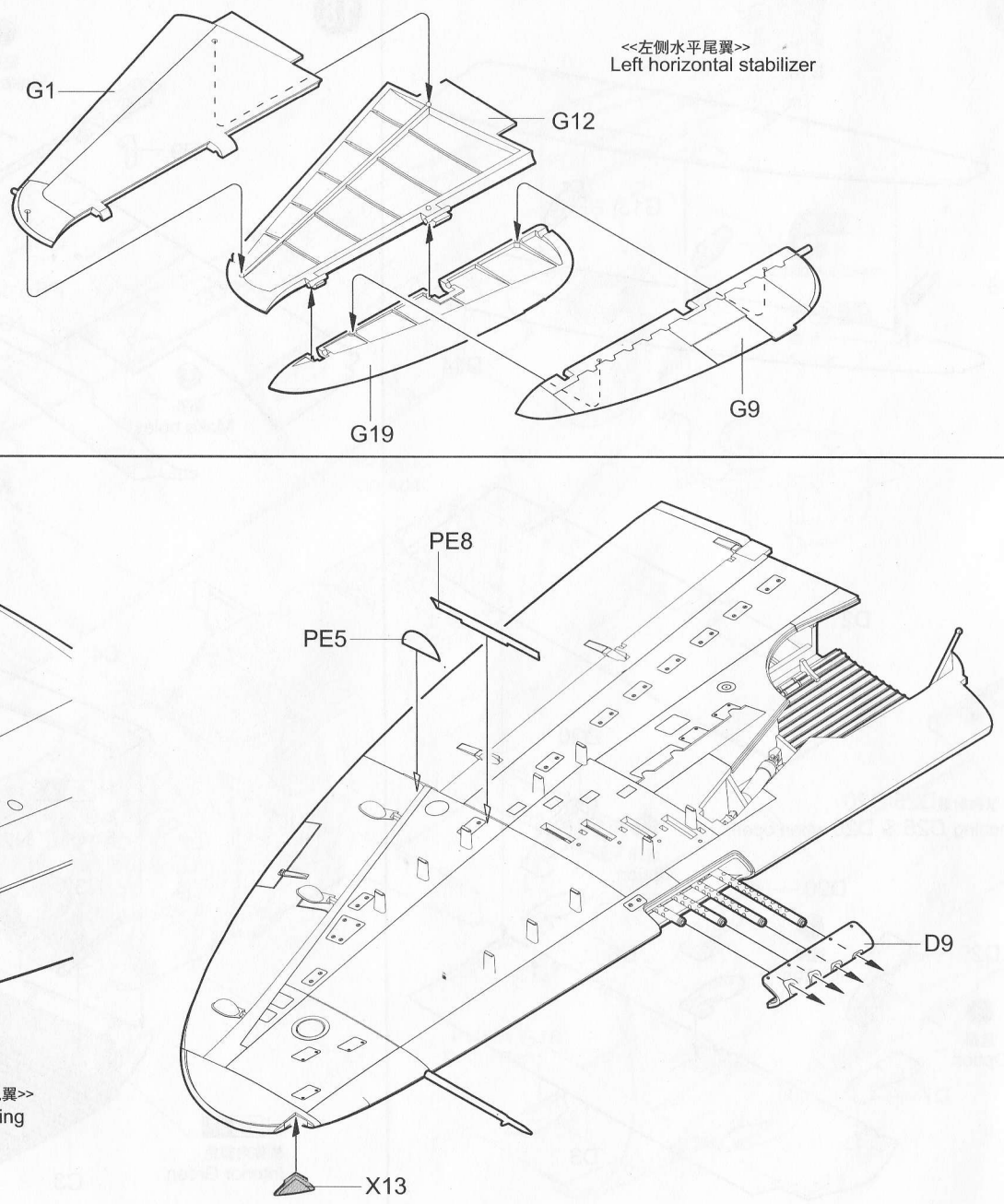

21

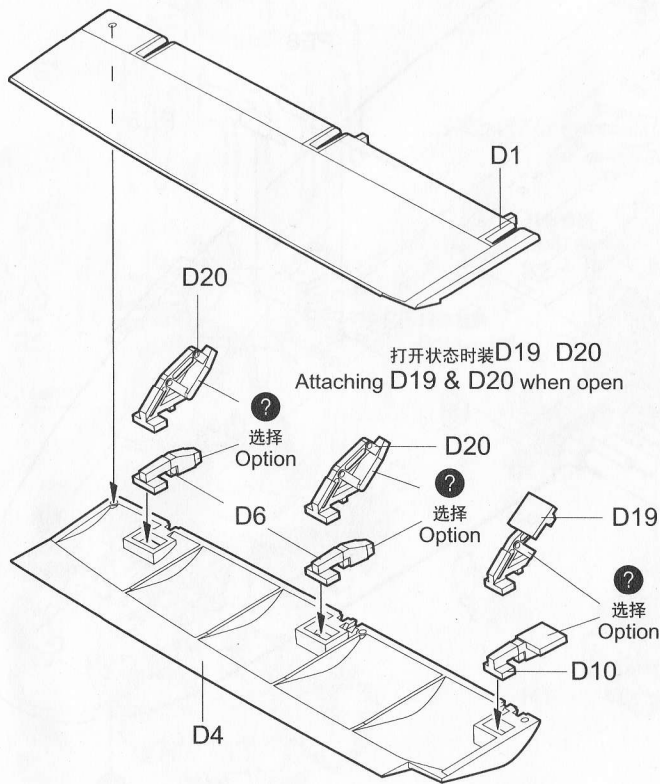
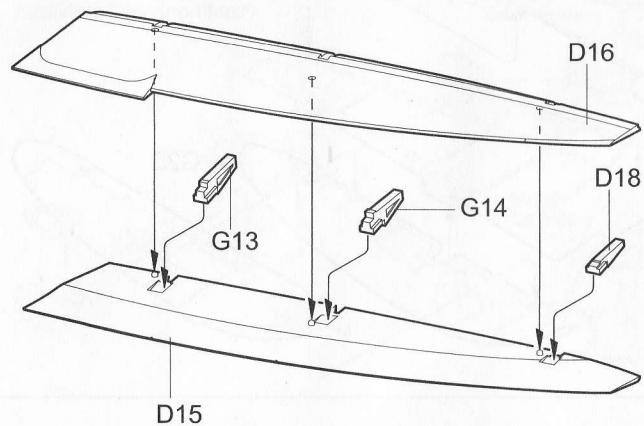

22

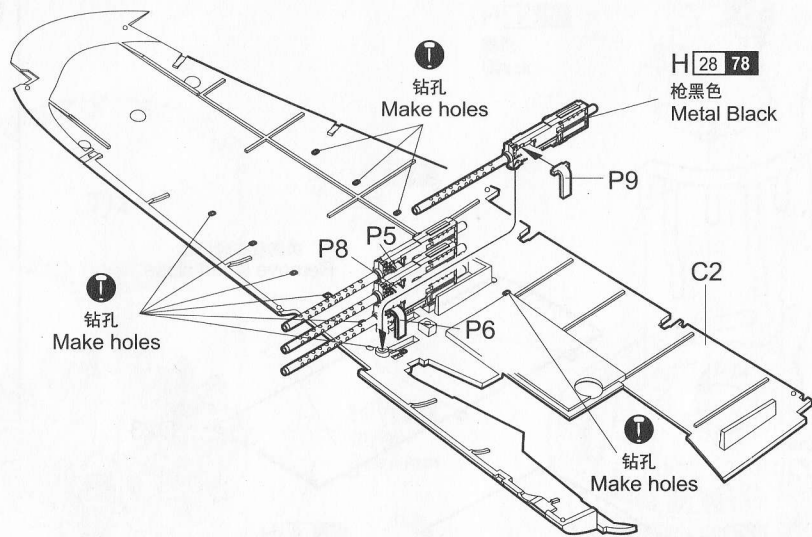

23

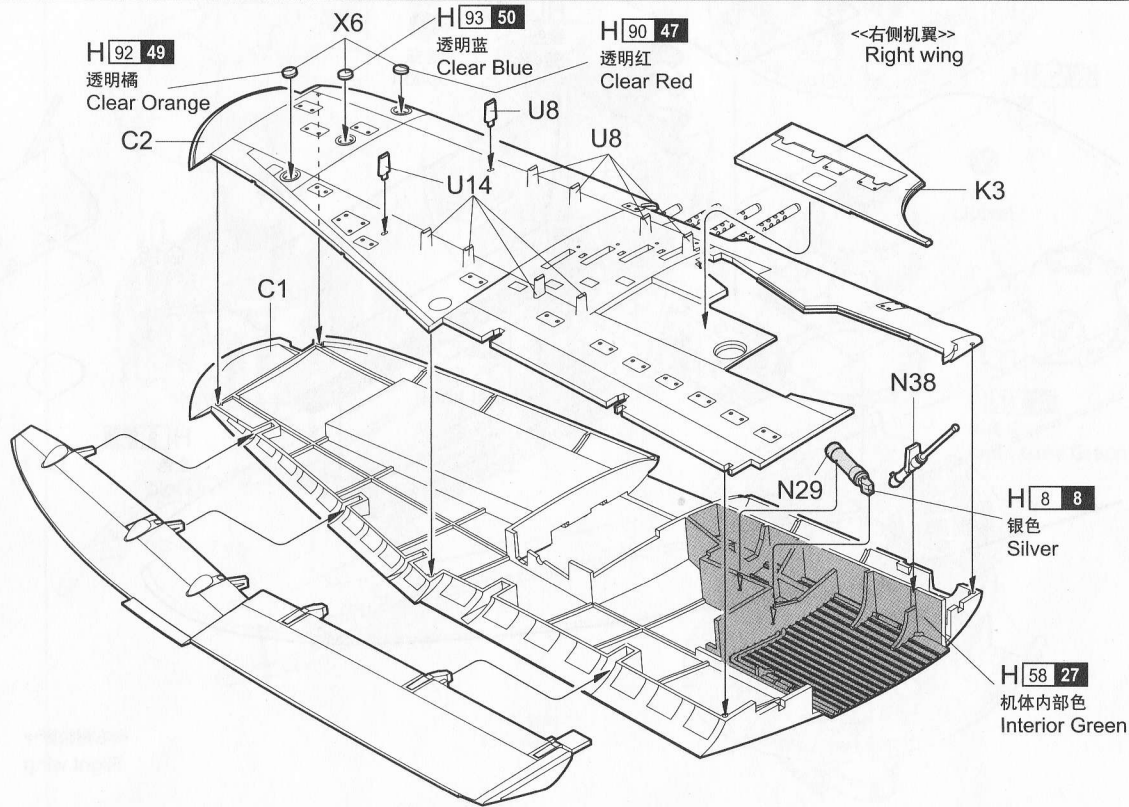

24

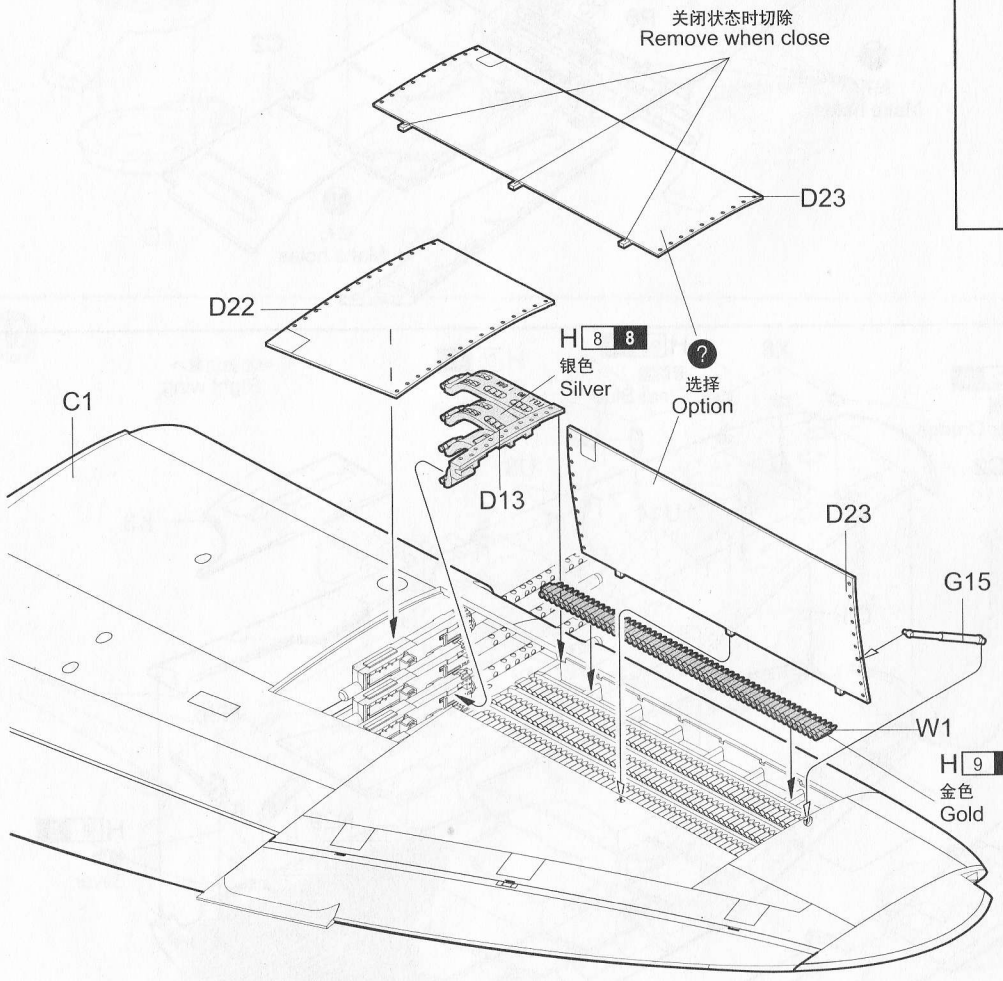

25

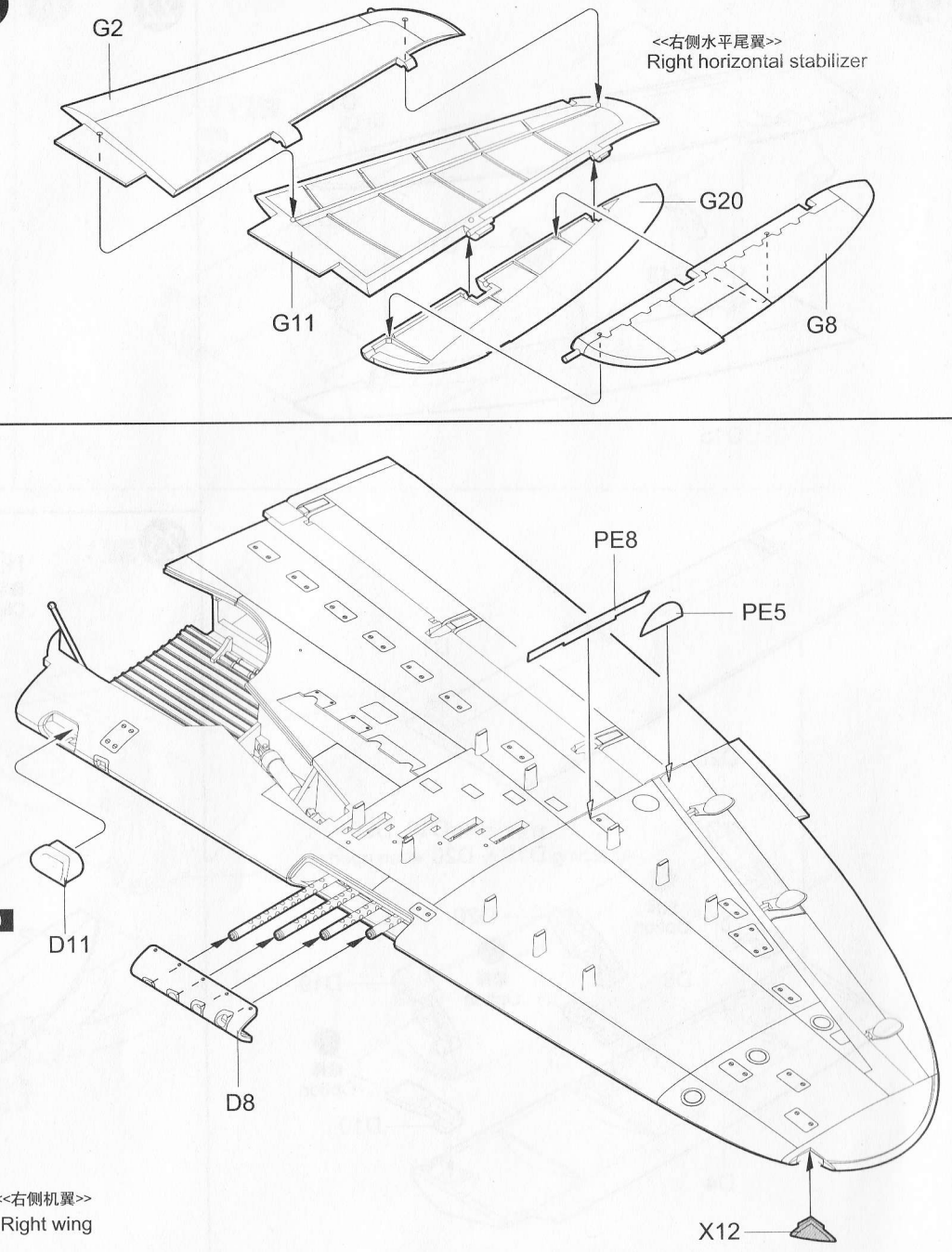

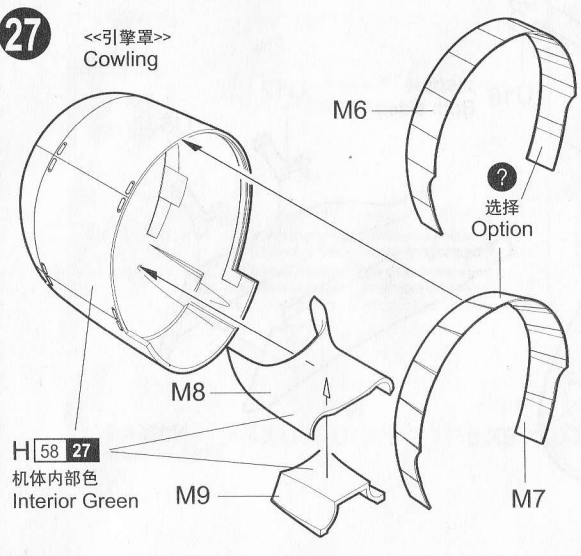
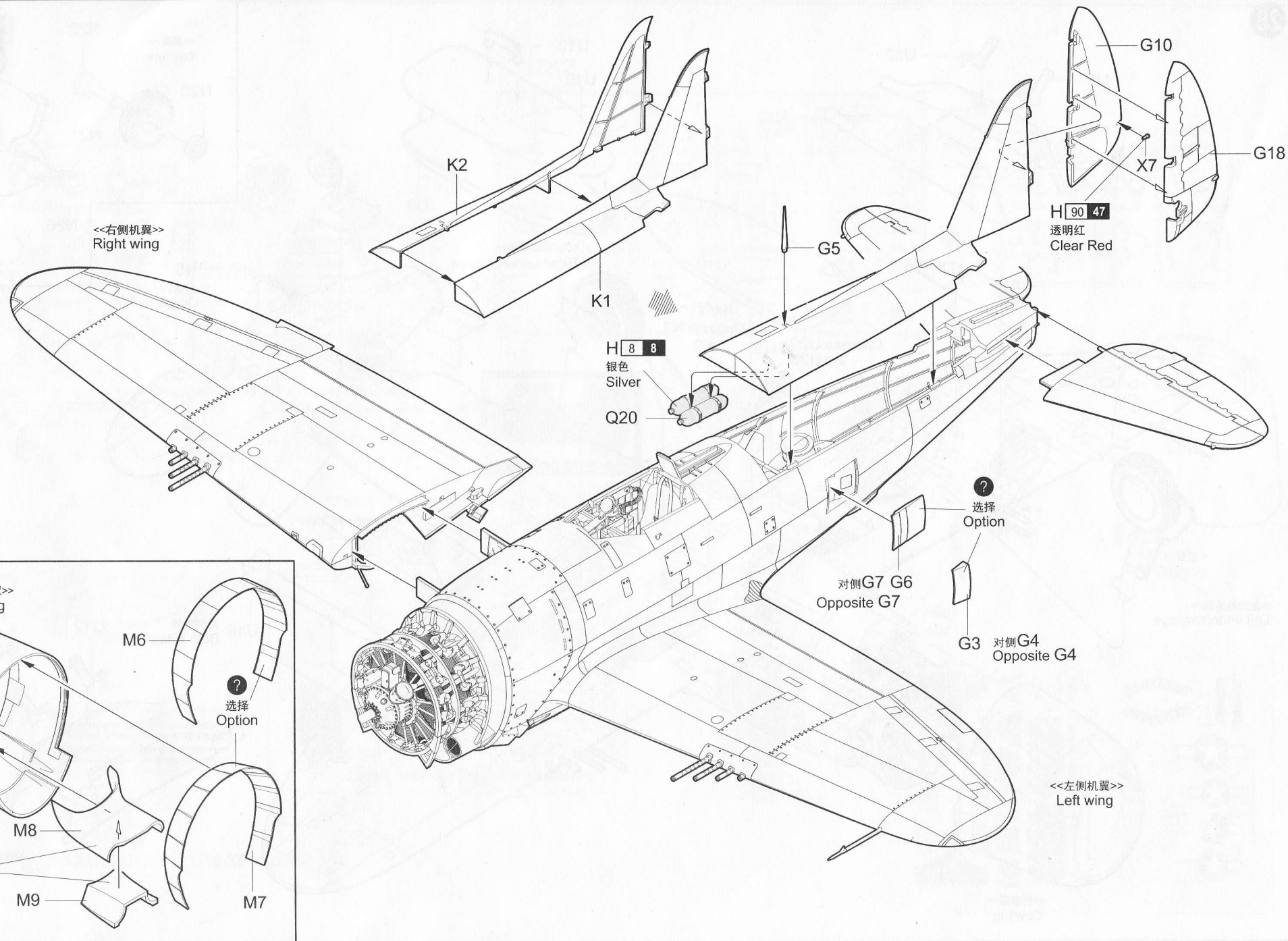

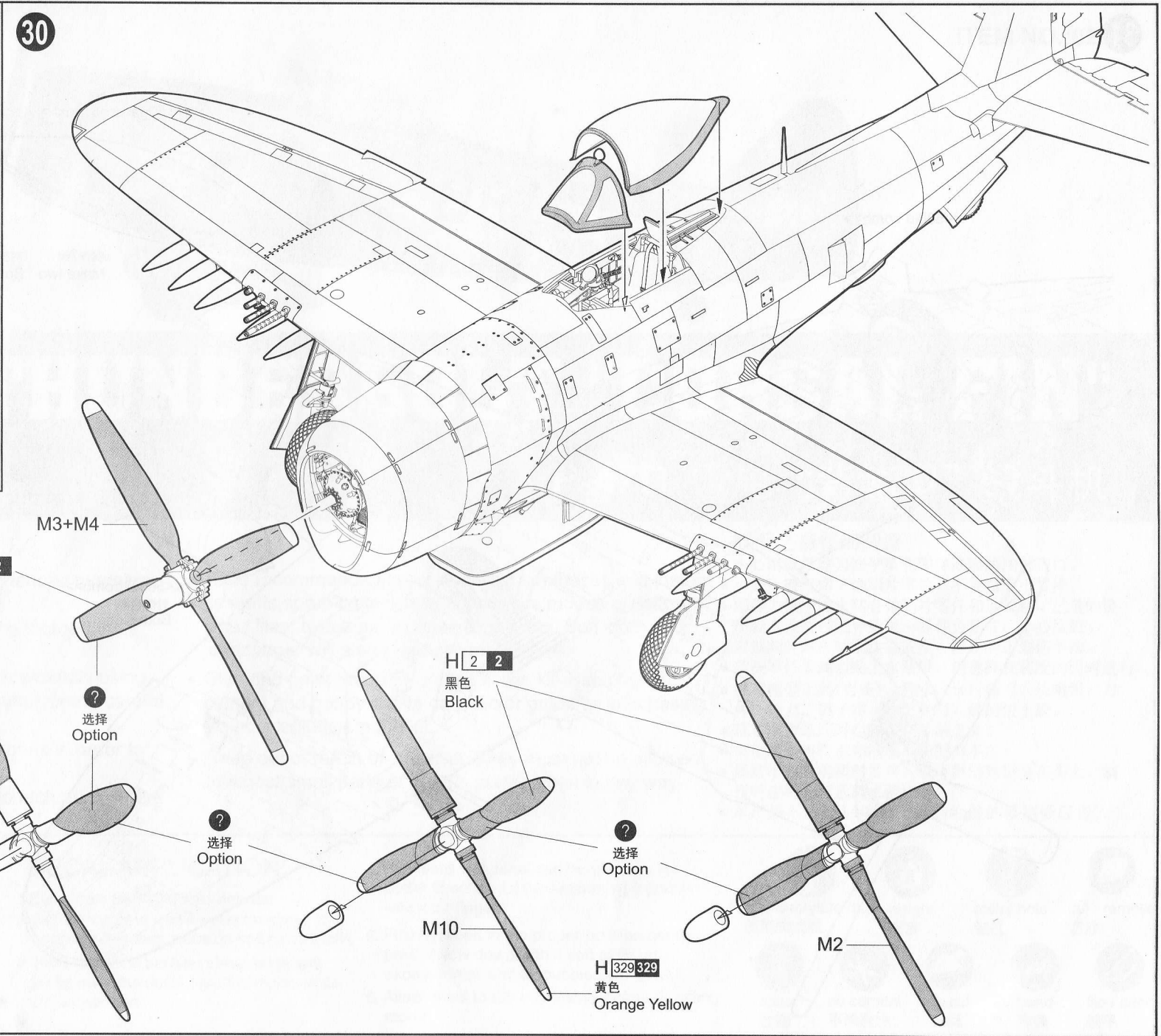
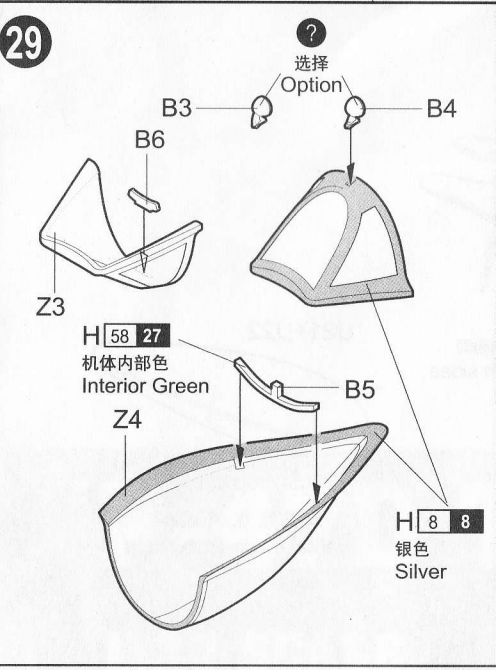

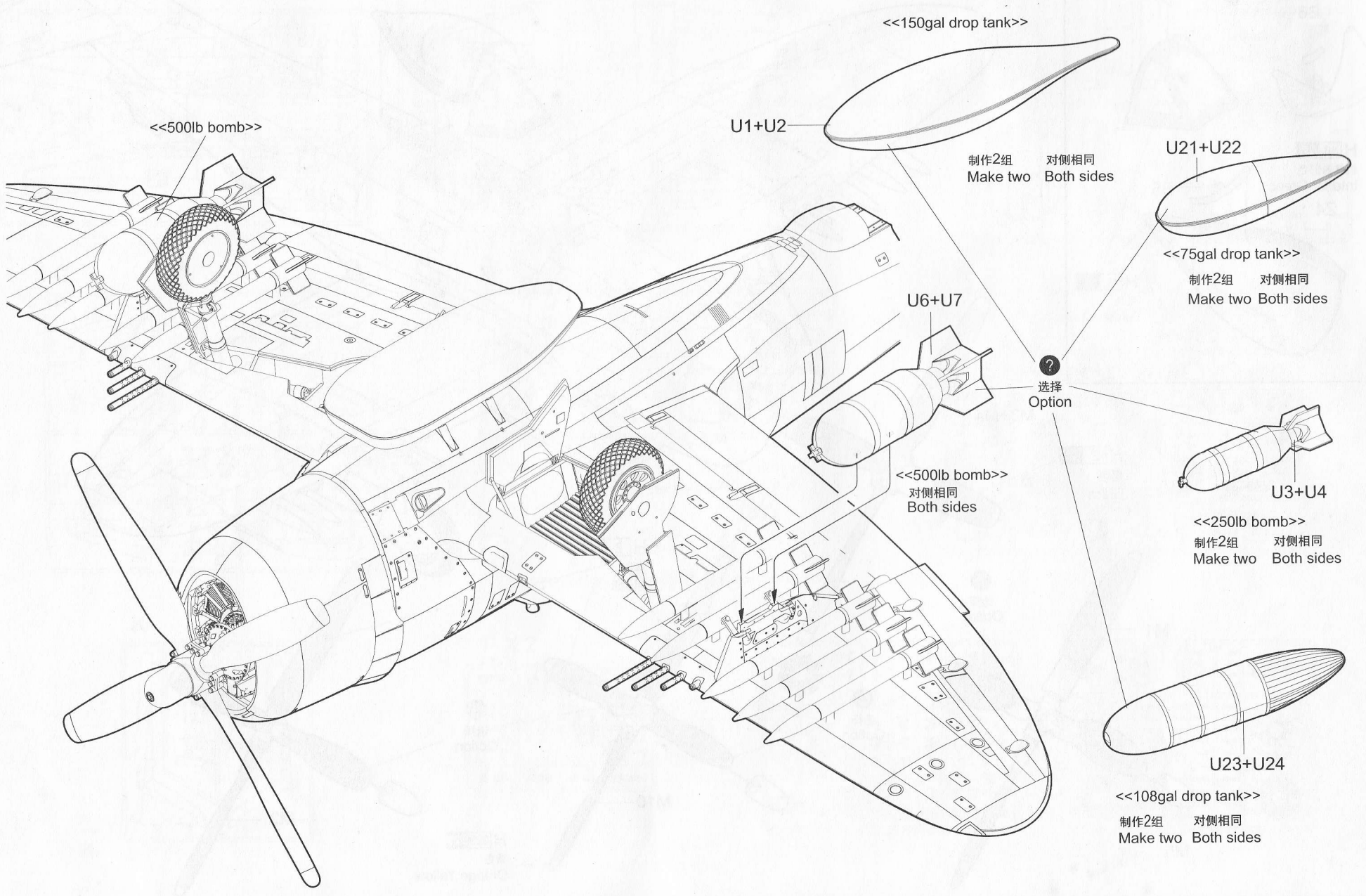

<<500lb bomb>>

<<150gal drop tank>>

U1+U2

制作2组 对侧相同
Make two Both sides

U21+U22

<<75gal drop tank>>

制作2组 对侧相同
Make two Both sides

U6+U7

?
选择
Option

<<500lb bomb>>
对侧相同
Both sides

U3+U4
<<250lb bomb>>
制作2组 对侧相同
Make two Both sides

U23+U24

<<108gal drop tank>>
制作2组 对侧相同
Make two Both sides

涂装同标贴指示 Painting & Marking guide

A

**COL JOE LAUGHLIN, THE COMMANDING
OFFICER OF THE 362nd FG.**

H 8 8	银色 Silver	H 76 61	烧铁色 Burnt Iron	H 304 304	橄榄色 Olive Drab
H 58 27	机体内部色 Interior Green	H 77 137	胎黑色 Tire Black	H 90 47	透明红 Clear Red
H 94	透明绿 Clear green				

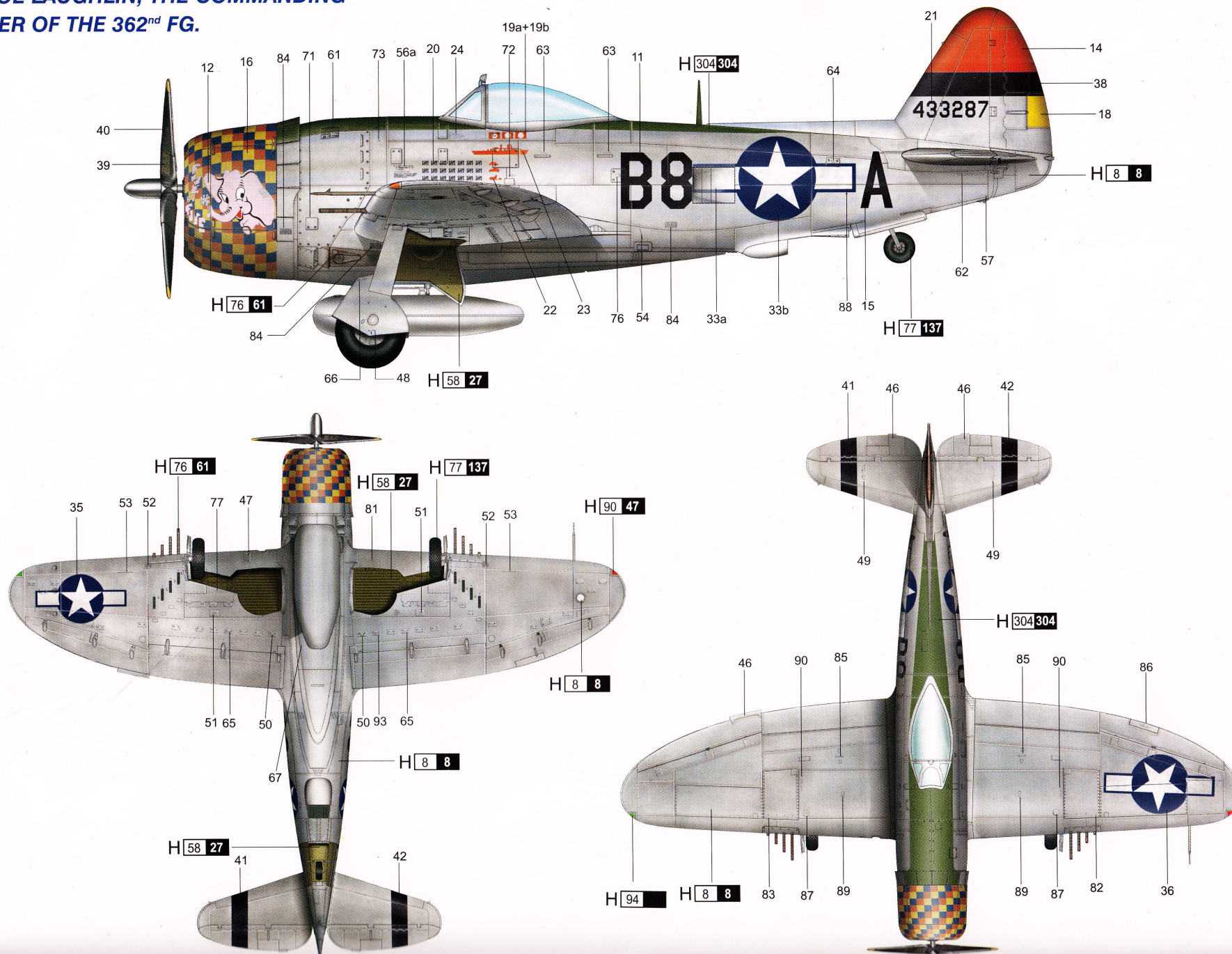

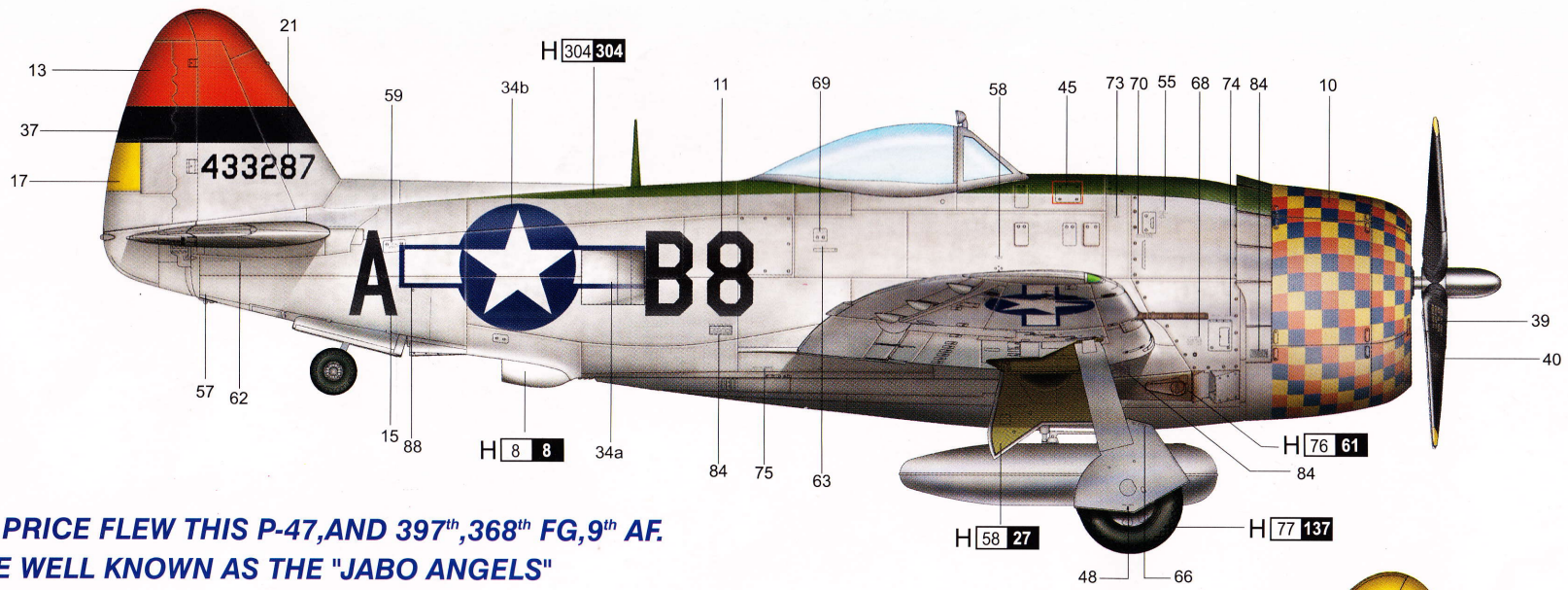

B

CLIFFORD PRICE FLEW THIS P-47, AND 397th, 368th FG, 9th AF. THEY WERE WELL KNOWN AS THE "JABO ANGELS"

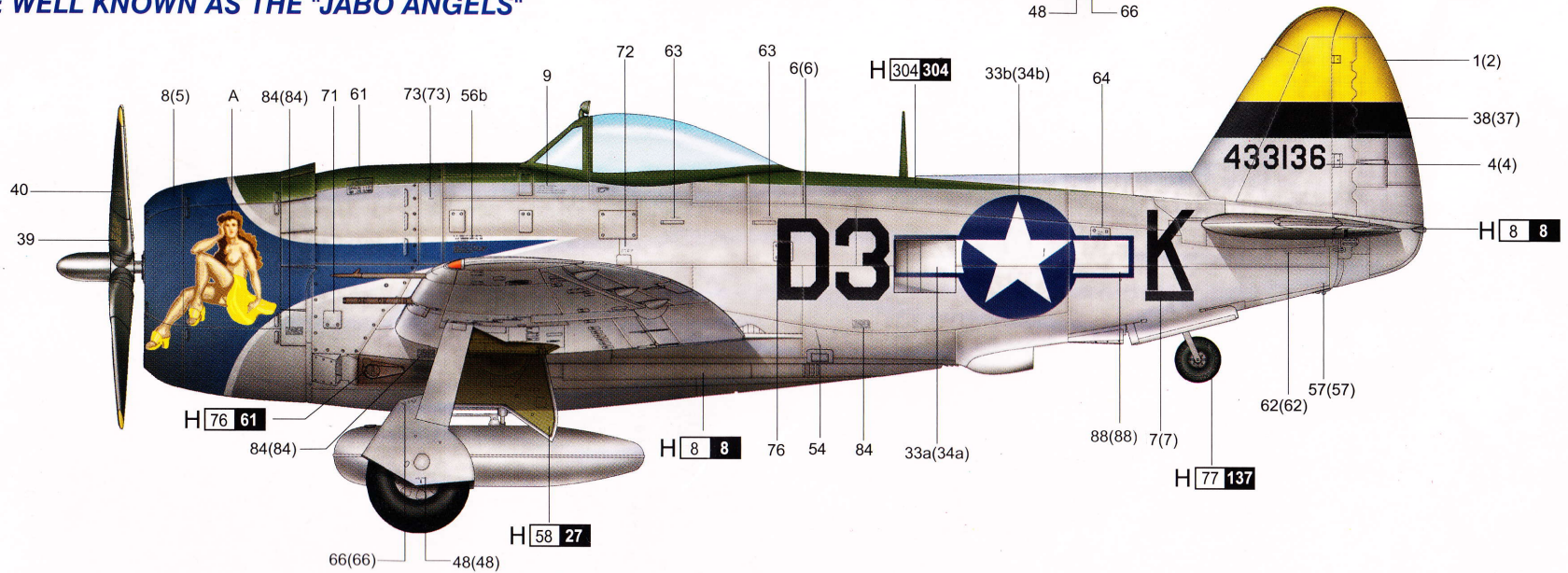

H [X] AQUEOUS HOBBY COLOR

[X] Mr. COLOR

使用 MR.HOBBY 涂料 Mr. Color Used

02264 1/32 P-47D THUNDERBOLT "DORSAL FIN"