

1:35 SCALE

ITEM NO.:01558

LAV III TUA (Tow-Under-Armour)

加拿大陆军LAV III TUA “陶”式导弹发射车



READ BEFORE ASSEMBLY:

- Study and understand these instructions thoroughly before beginning assembly
- When needed, remove photo-etch parts carefully using a modeling knife or photo etch sprue cutter, being careful not to damage or lose small parts.
- Take extra care in handling photo etch parts in order to avoid injury
- Apply instant cement sparingly to photo etch parts where instructed
- Tools recommended(not included in kit):Plastic and instant cements, sprue cutters,long nose pliers,modeling knife, small files, tweezers, pin vise & scissors. Soft cloth and sandpaper will also assist in construction
- Glue and paint are not included in the kit. Use plastic cement and hobby paints only. Color guide for purchasing paint is included in the kit.

装配之前仔细阅读

- 小心用模型锉刀锉平所有零件表面的注射浇口。
- 小心用刀片切下蚀刻片零件，不要遗失小零件。
- 用强力快干胶水粘合蚀刻片零件和金属轴。过量快干胶水使用可能导致可动零件会粘住，小心涂胶。
- 取蚀刻片时应特别注意安全，防止利边划伤手指。
- 某些零件表面需贴上水贴纸，请选择在装配的同时进行。
- 推荐模型工具(自备)：胶水，水口剪刀，长咀钳，刀片，锉刀，镊子，钳，钻，剪刀，瞬间快干胶。
- 软布同砂纸同时也应该是必备工具。
- 请使用塑料胶水和油漆，模型内不含。



配重
Weight



使用强力胶
Cyanoacrylate glue



钻孔
Make hole

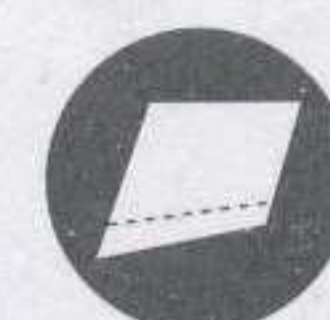

切除
Cut / Remove



贴纸
Decal



锉平
File / Sand



选择
Option



不涂胶水
No cement



弯曲
Bend

水贴纸的使用:

- 1.从水贴纸上剪下印花;
- 2.将印花放入温水中浸10秒，然后放在干净布上。
- 3.拿着印花纸板将印花移到模型上;
- 4.手指蘸水将印花移到适当的位置;
- 5.用软布轻压印花直至水干，汽泡消失

DECAL APPLICATION

- 1.Cut decals from sheet as needed
- 2.Dip the decal in warm water for about 10 seconds and then place on soft clean cloth.
- 3.Hold the decal backing sheet edge and gently slide the decal onto the model in its proper position.

- 4.While still wet,decal can be adjusted for better fit on model by dampening it gently with your finger.
- 5.When placed in the proper position,gently press decal down with a soft cloth until excess water and air bubbles are gone.
- 6.Allow decal to dry completely before handling model

部品图 Parts

Ax2

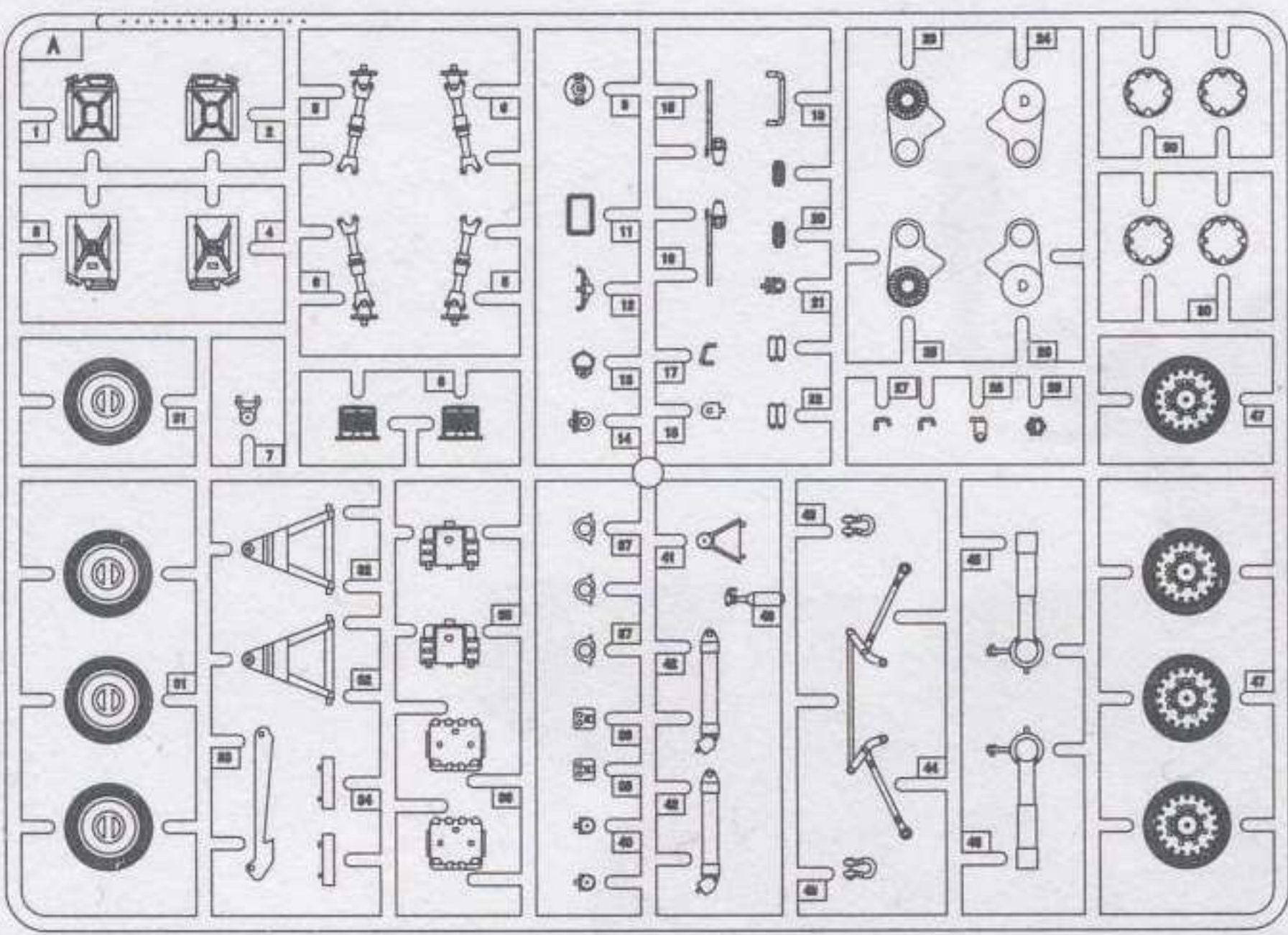

B

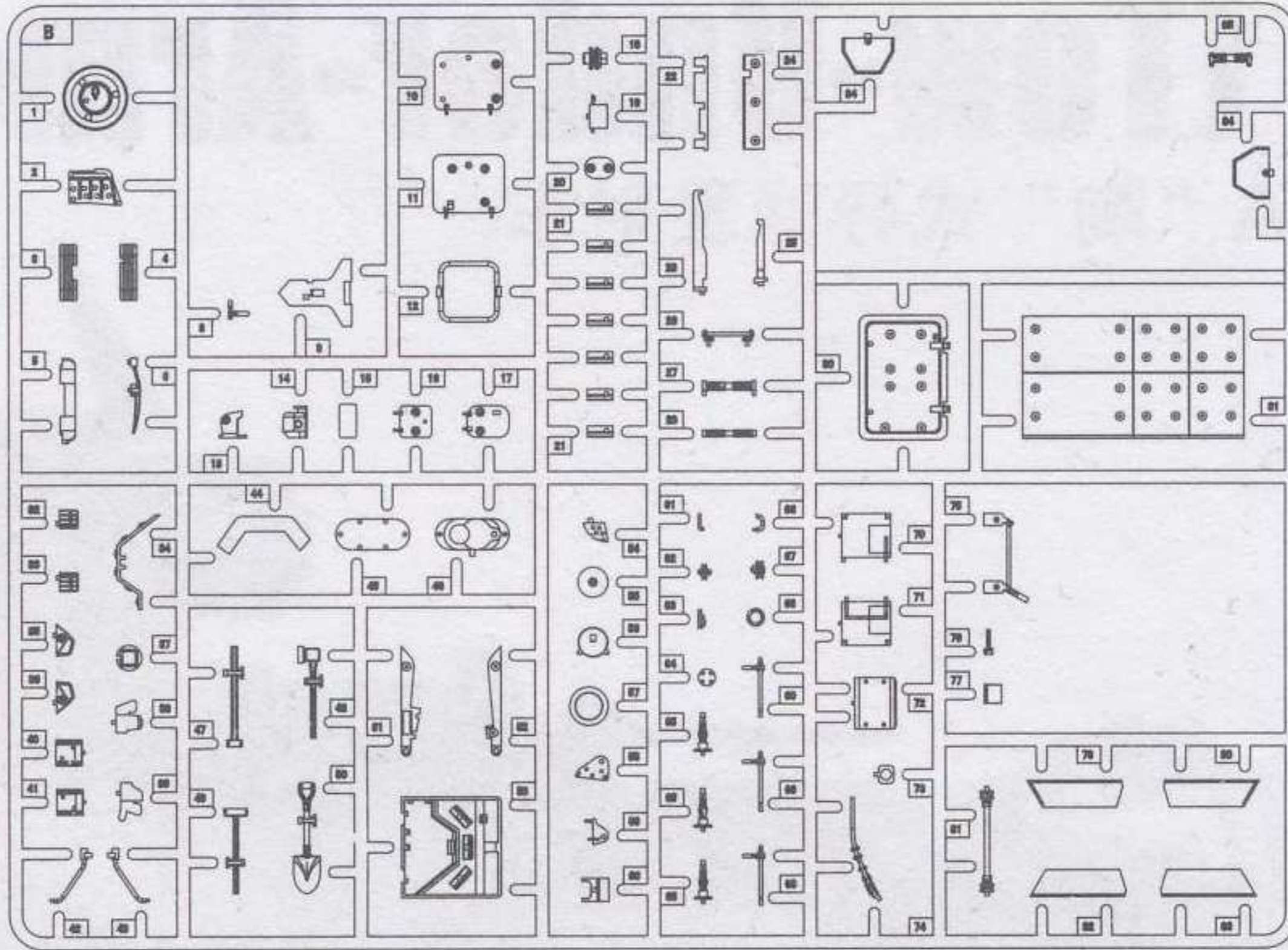

C

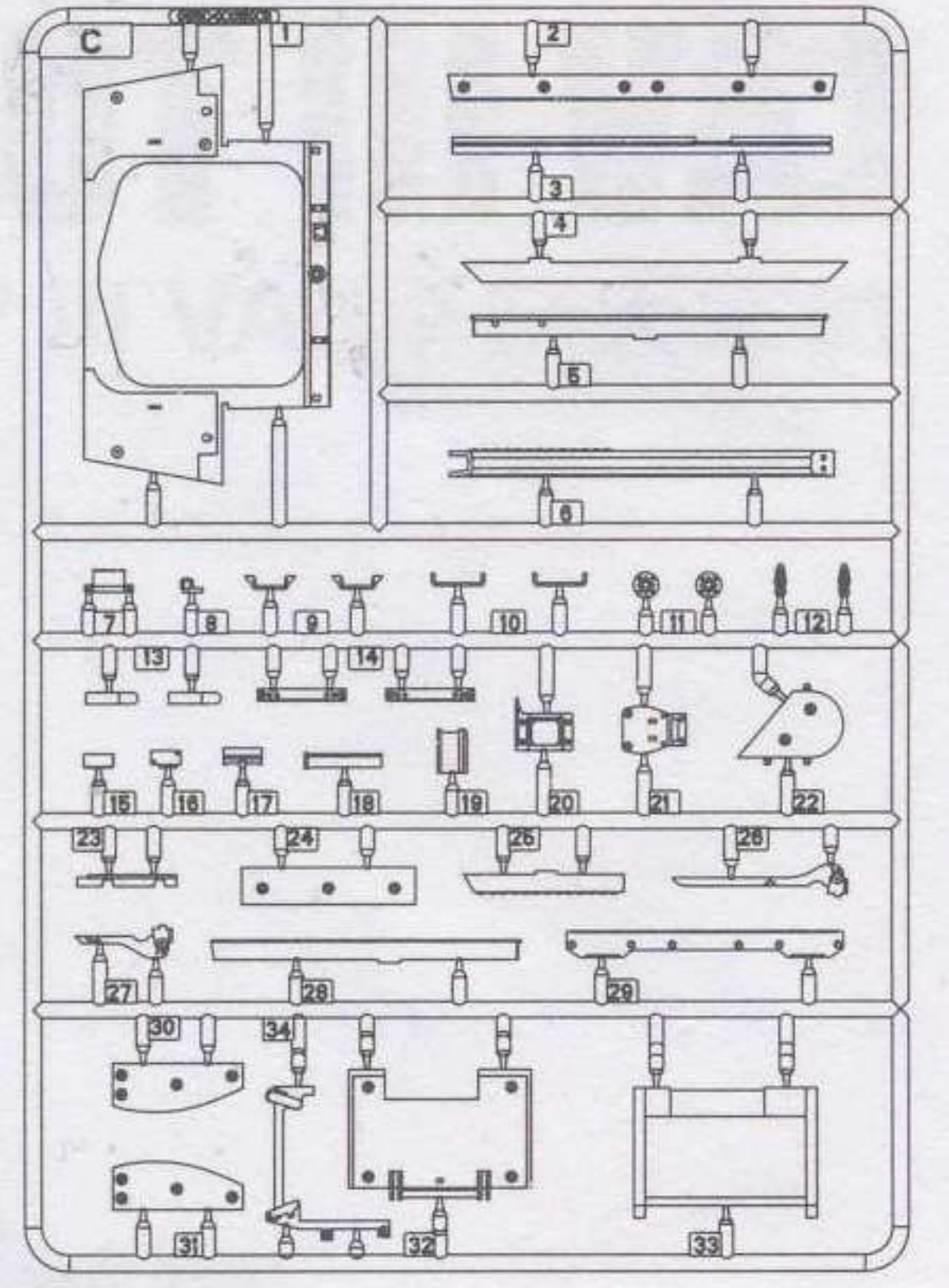

E

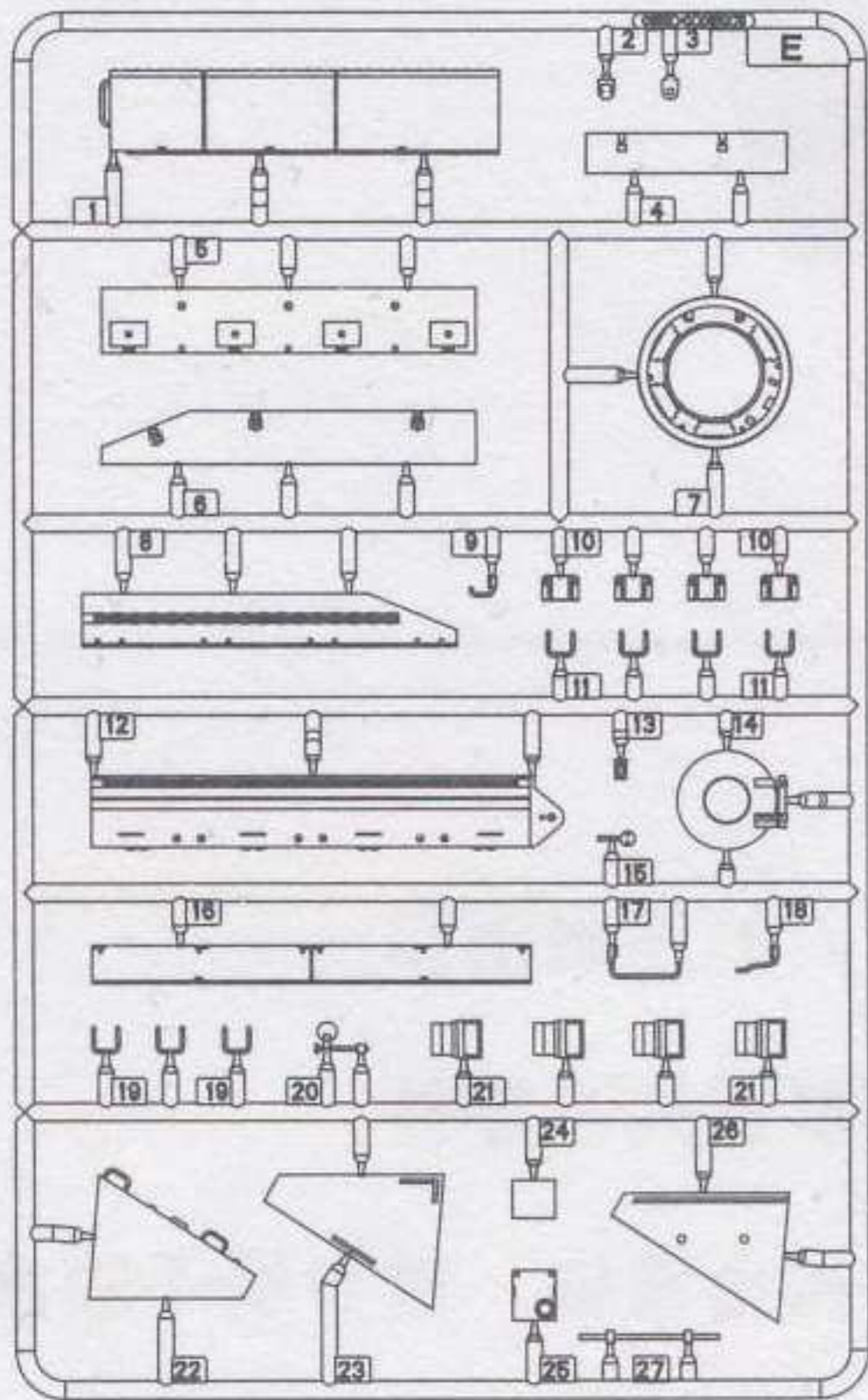

D

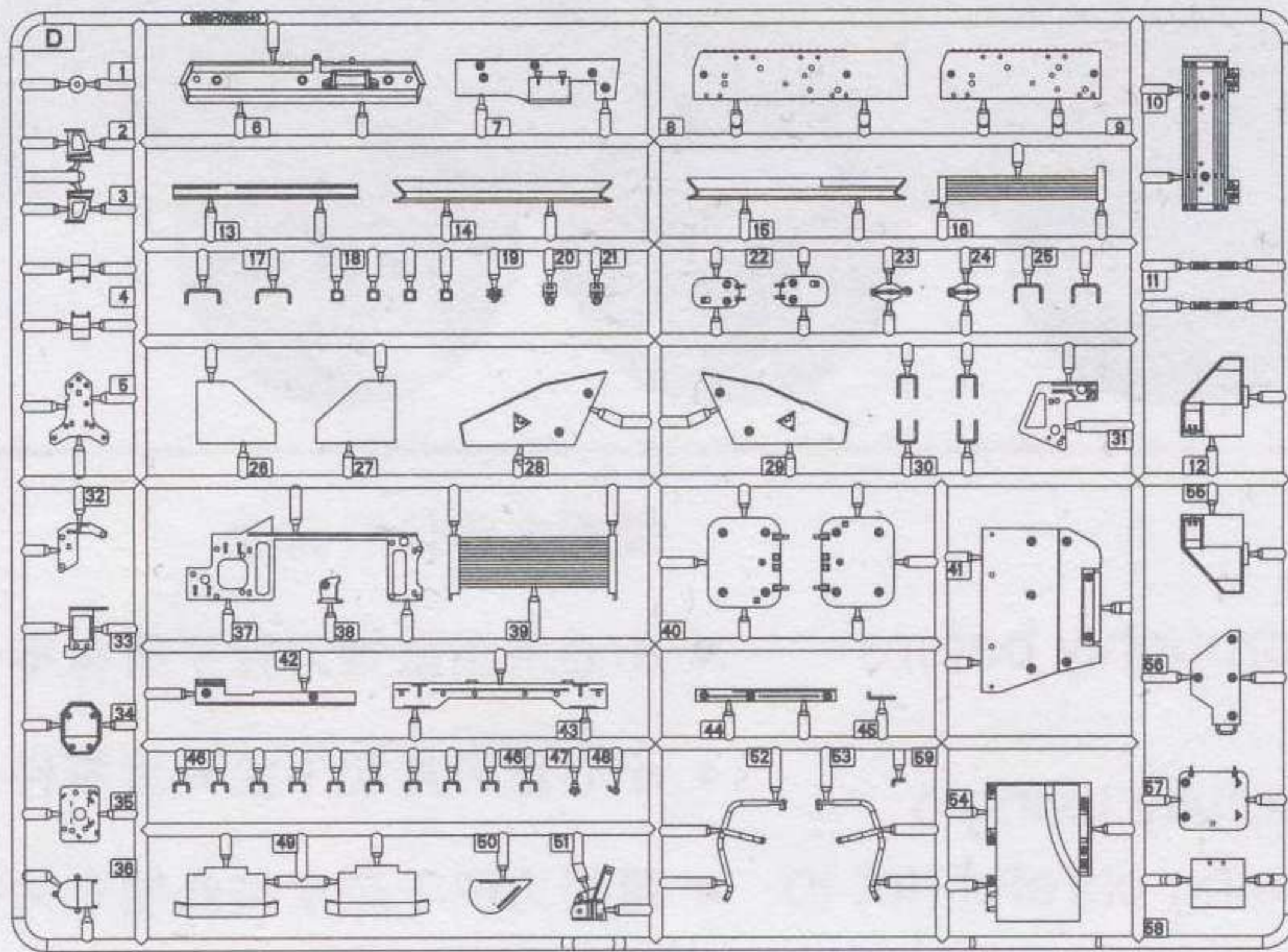

G

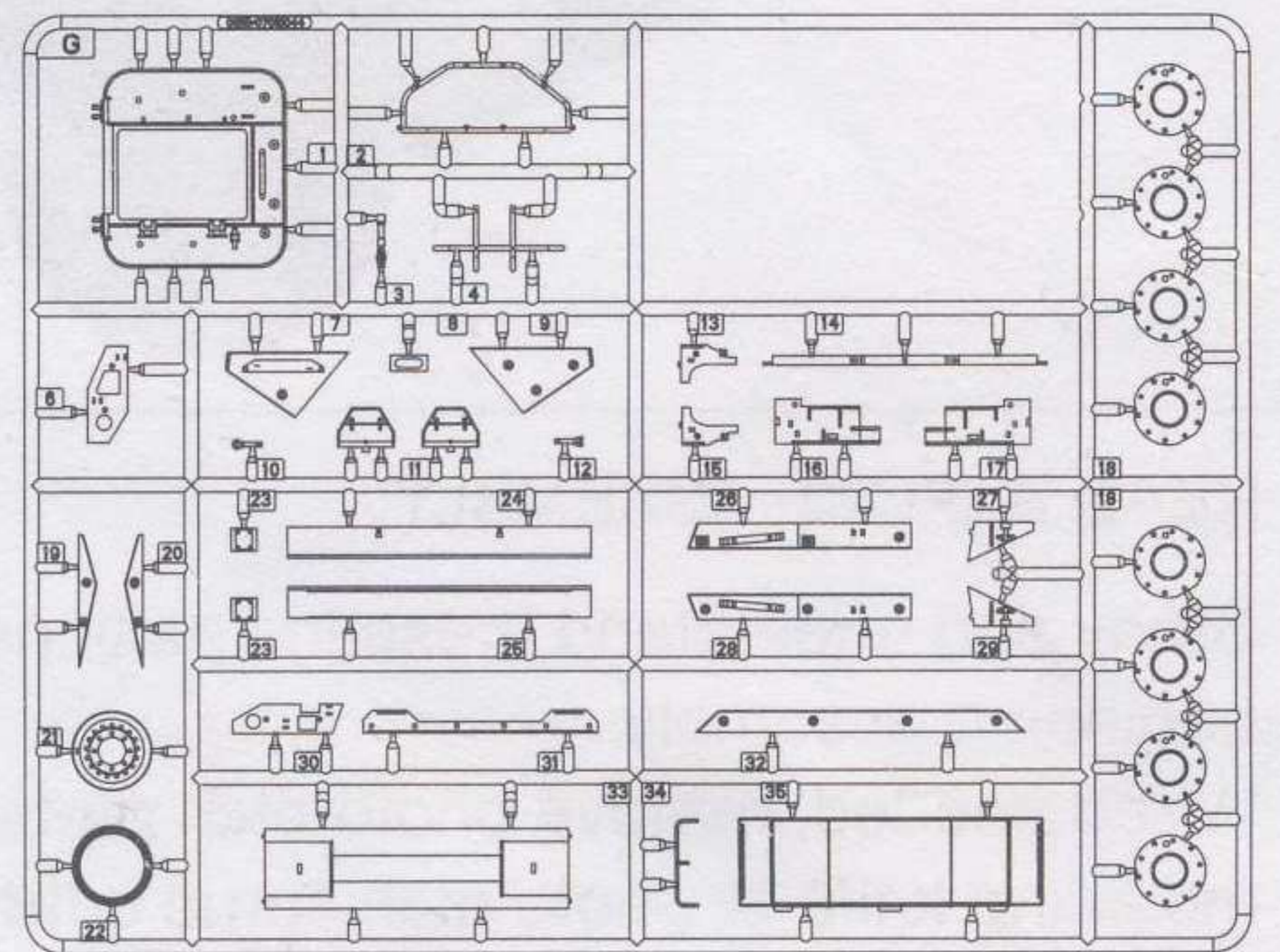

F

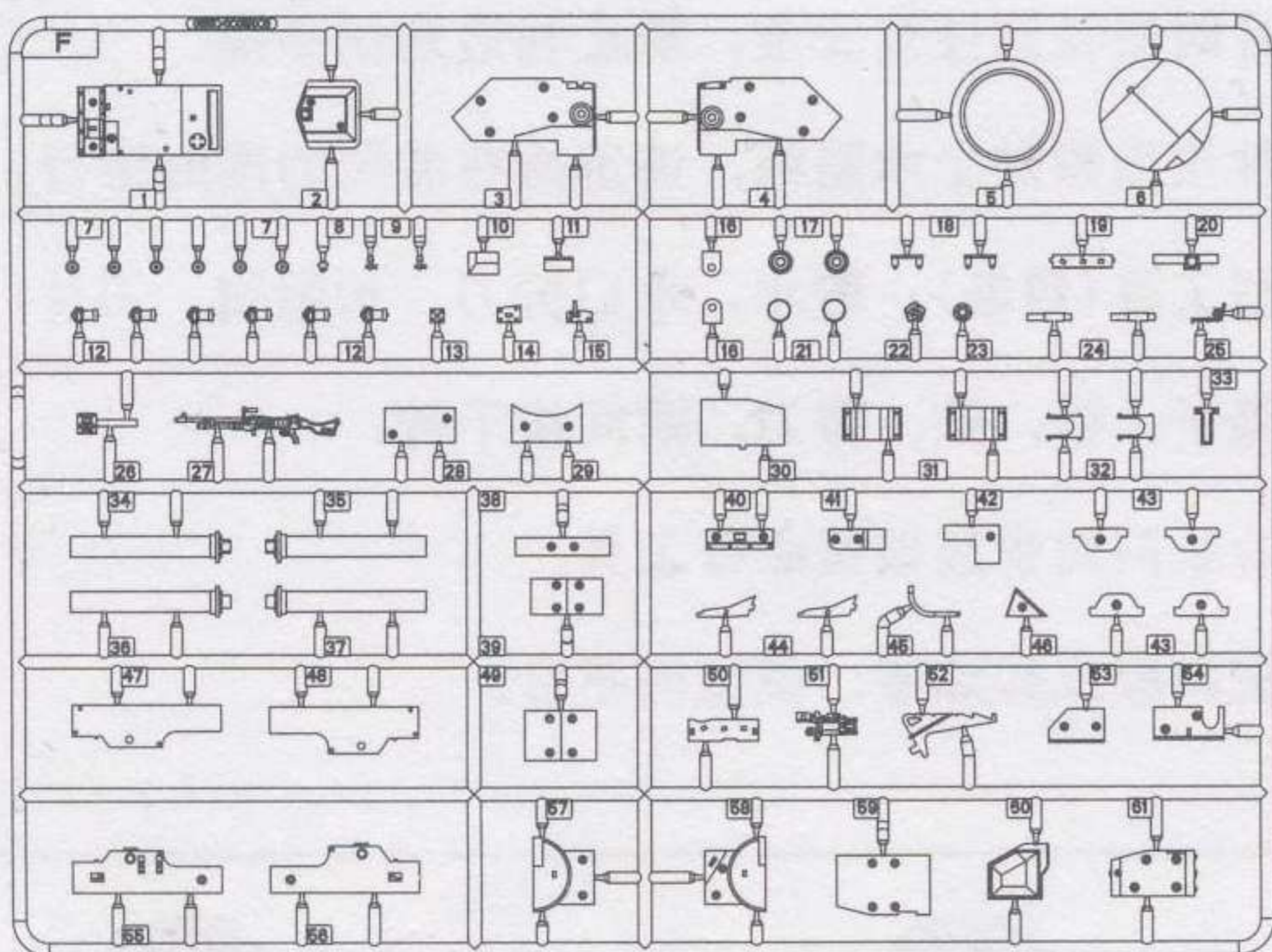

R

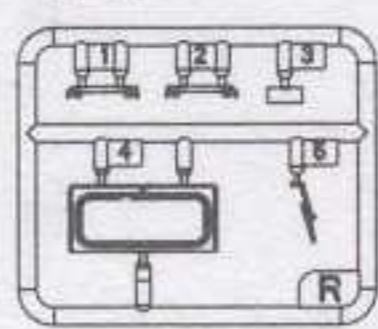

N

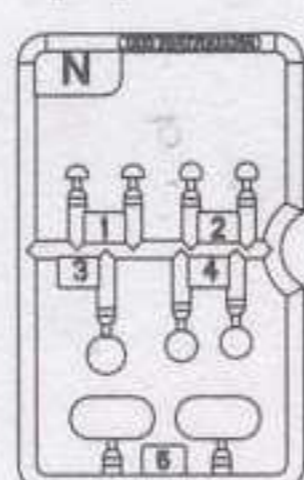

P

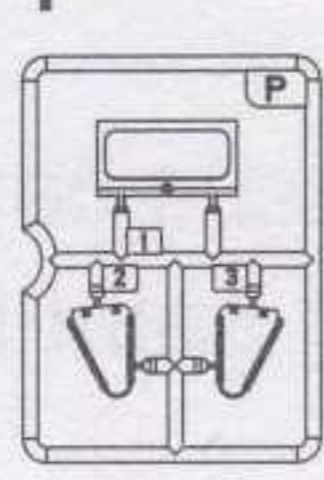

《车面》
Upper hull

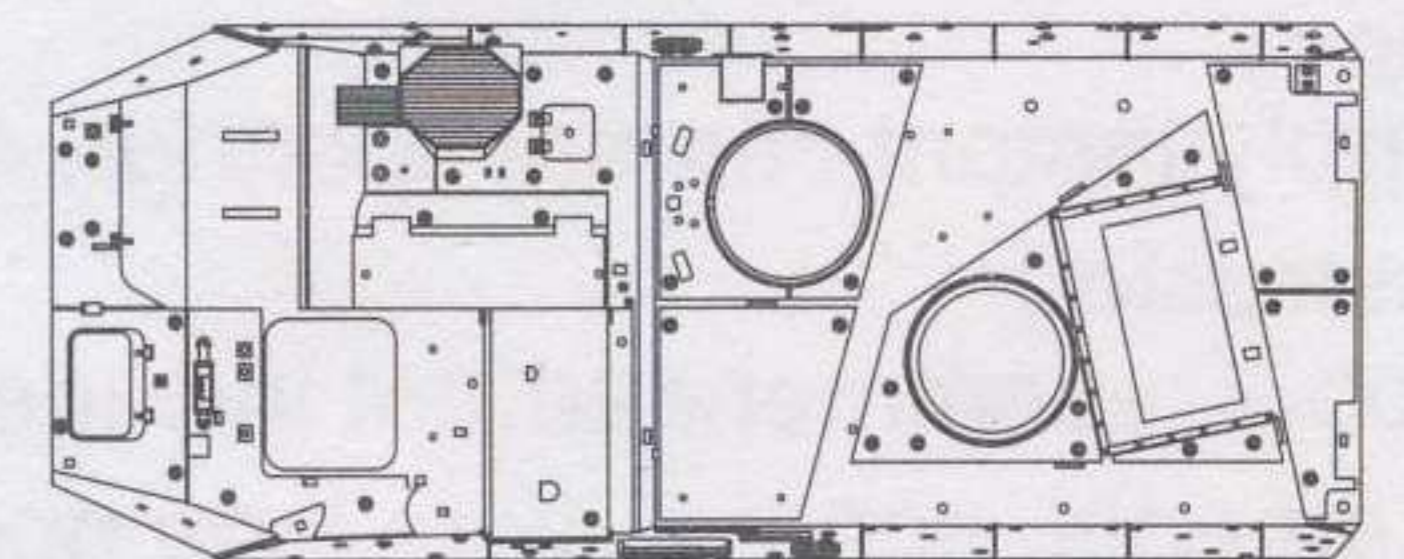

《车底》
Lower hull

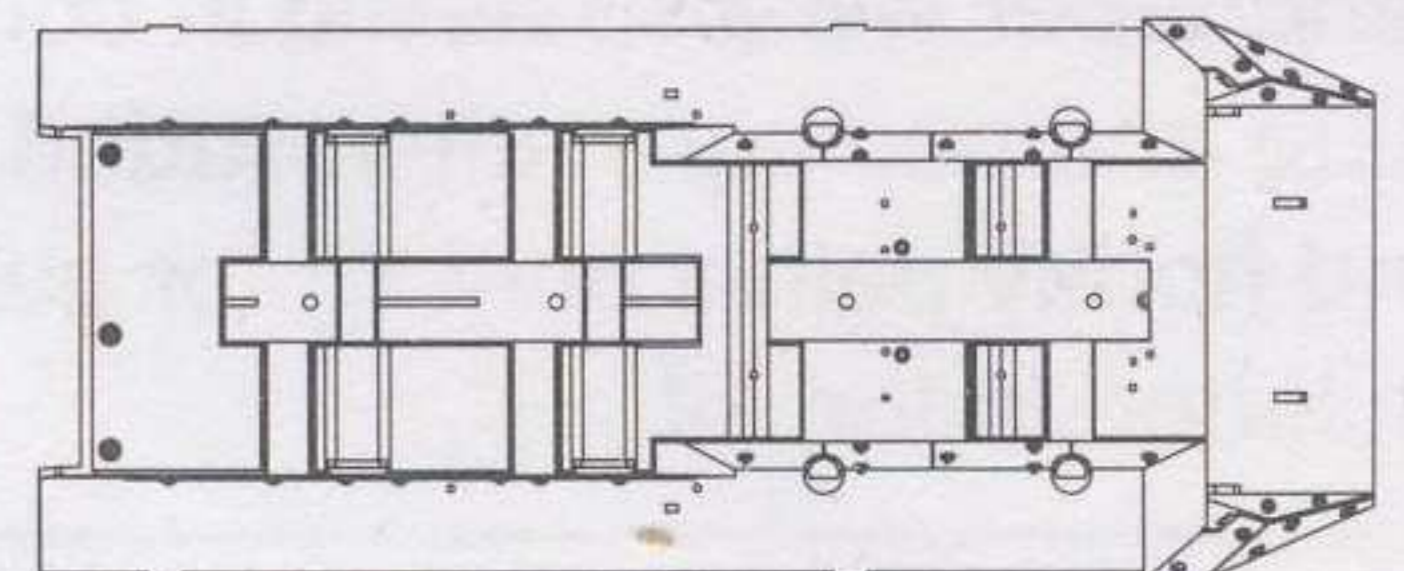

《铜缆》 \varnothing 0.8X500mm
Brass wire

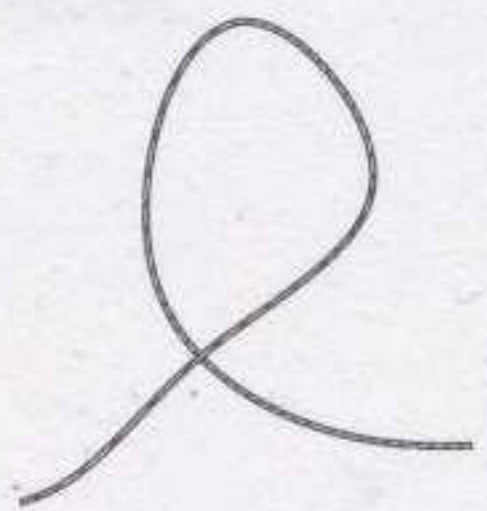

《轮胎》 $\times 9$
Tyre

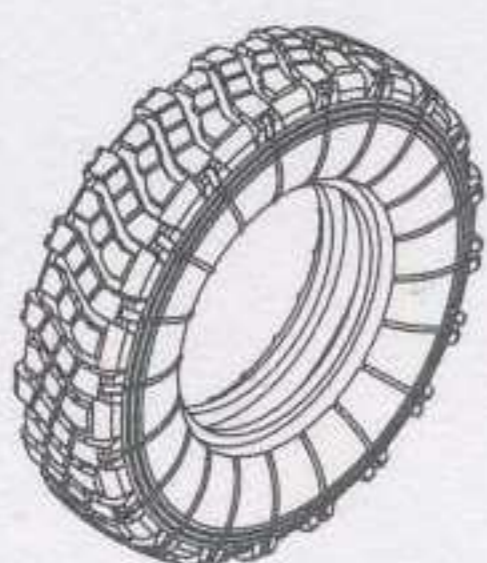

蚀刻片A
PE-A



蚀刻片D
PE-D

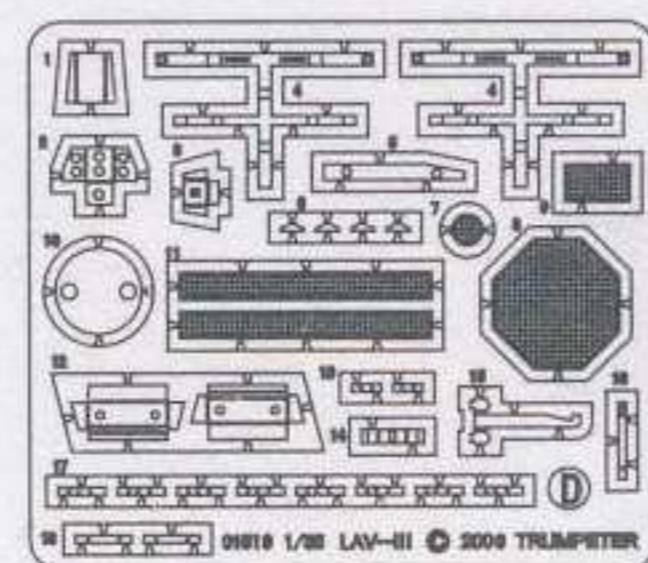

《铜丝》 \varnothing 1.0 \times 10mm
Copper-wire



《水贴》
Decal

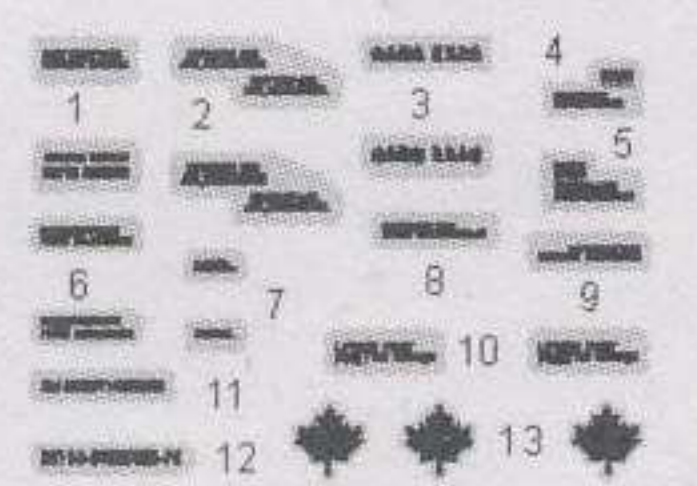

01558 1/35 LAV III TUA
(Tow-Güter-Anhänger)

《饮料箱》
Beverage Boxes

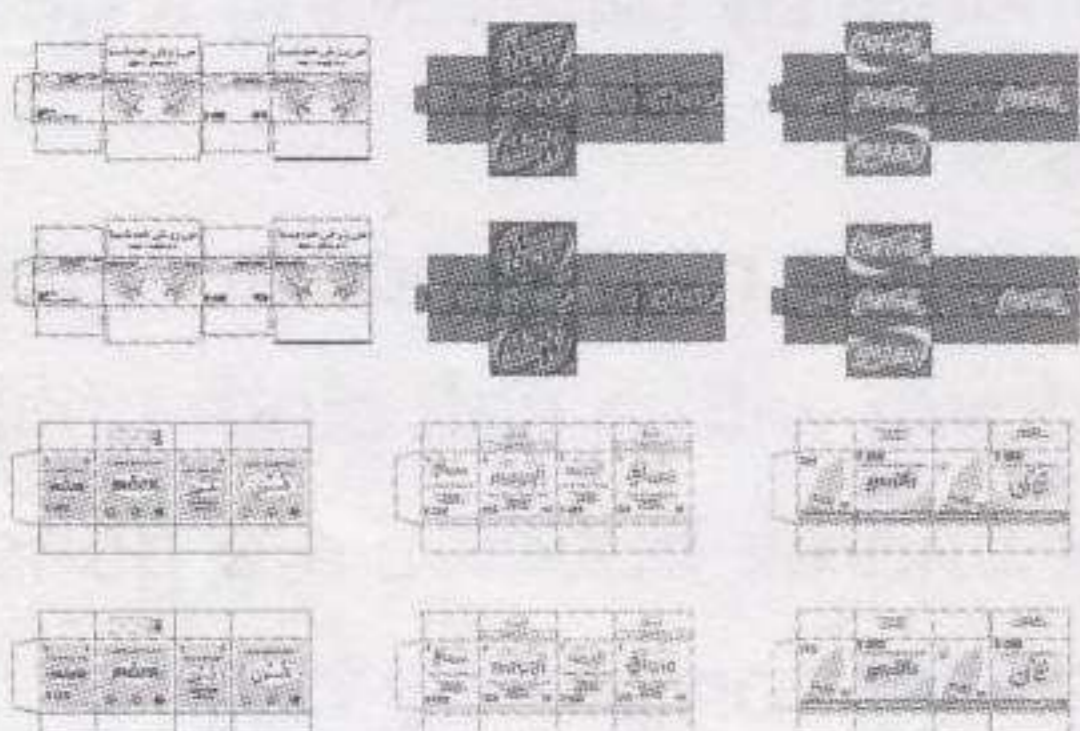

《食品箱》
MRE ration packs

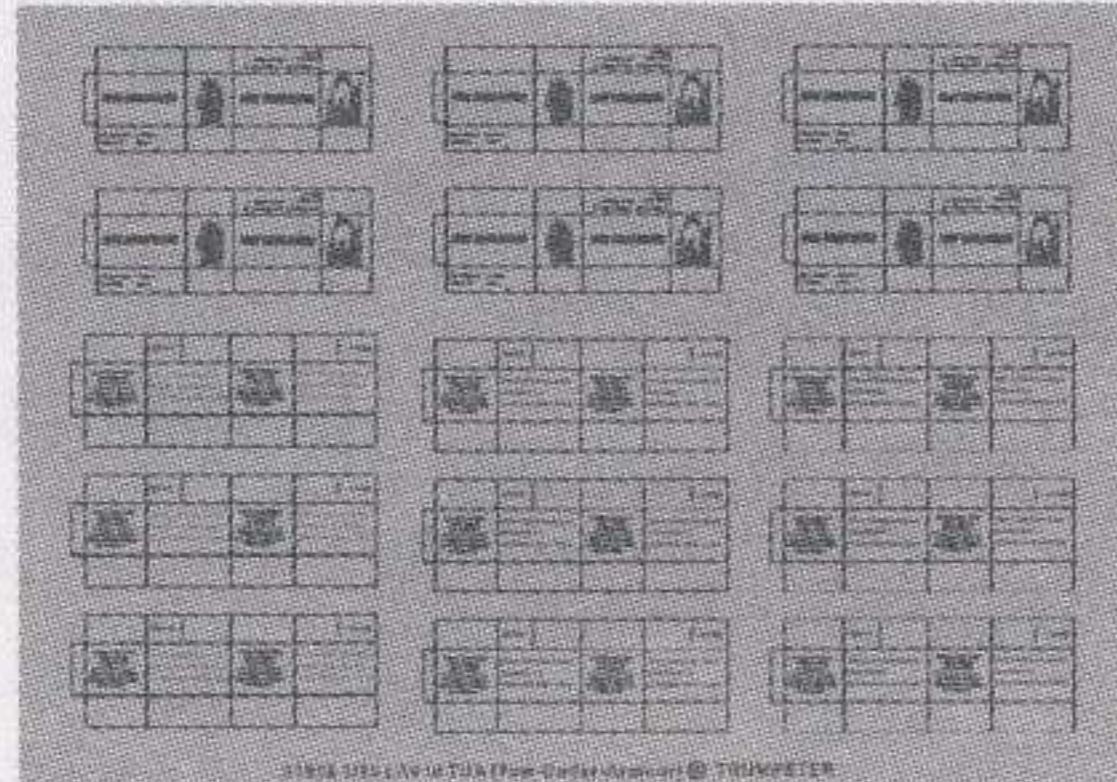

《遮盖纸》
Mask



不用部品: A22, A30, B5, B9, B10, B12, B13, B14, B17, B19, B21, B23, B27, B28, B32, B33, B35, B36, B47, B57, B64, B65, B67, B70, B71, B73, B76, B77, B84, B85, D9, D11, D14, D15, D17, D32, D36, D40, D42, G3, G14, G23, G26, G28, G31, G32, G34, N3, N5

1 车底组装
Lower hull assembly

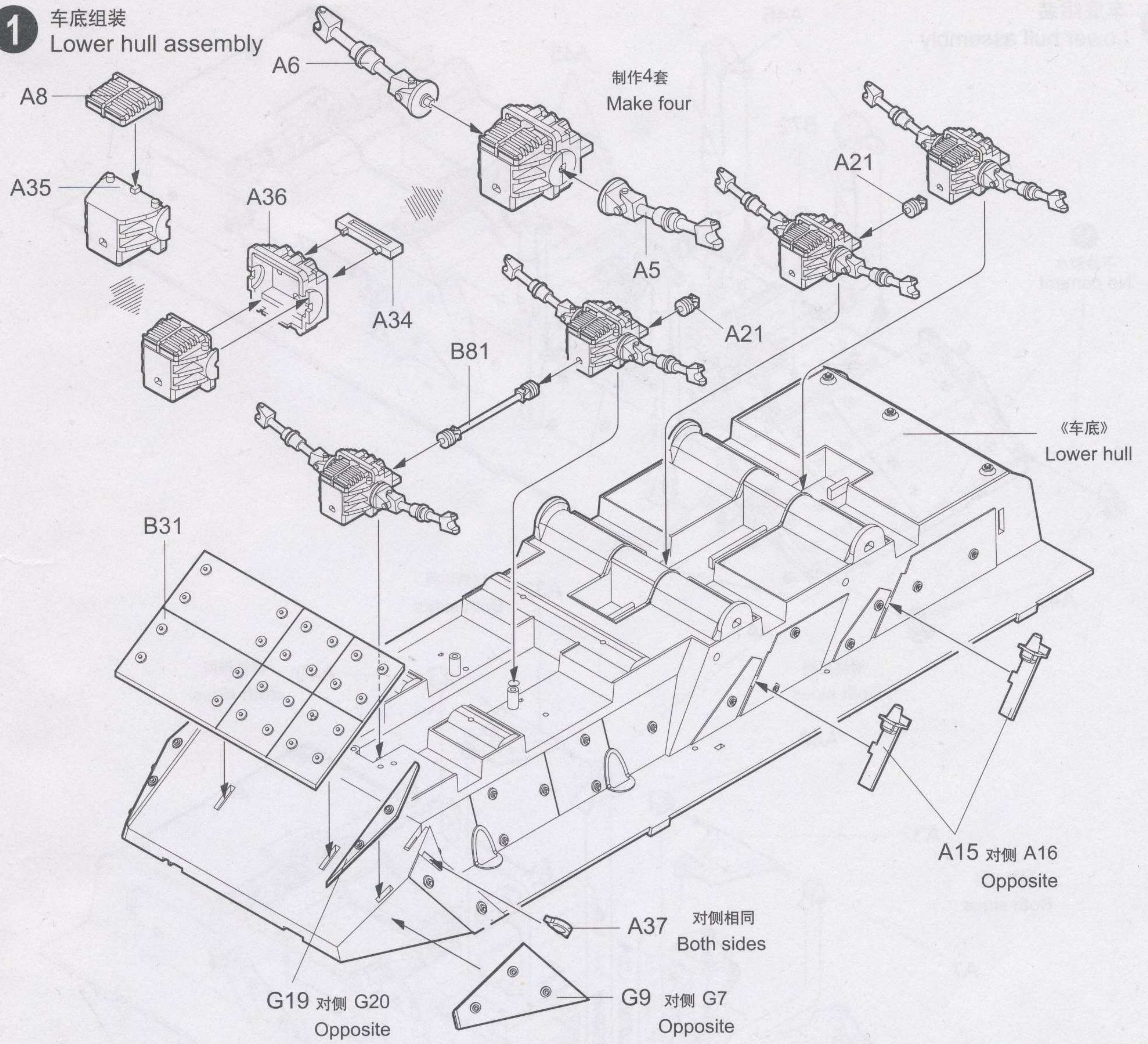

2 车底组装
Lower hull assembly

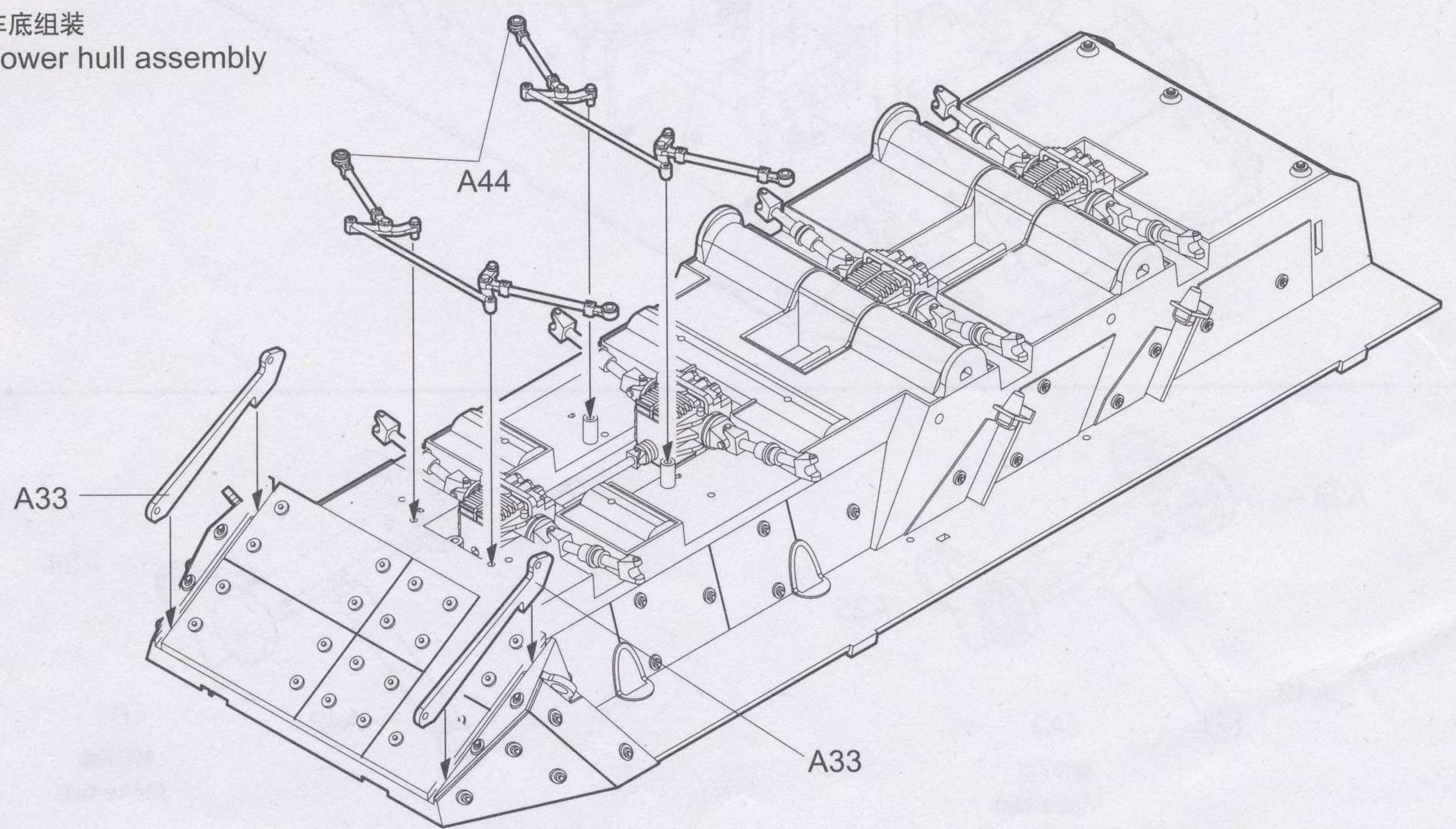

3 车底组装
Lower hull assembly

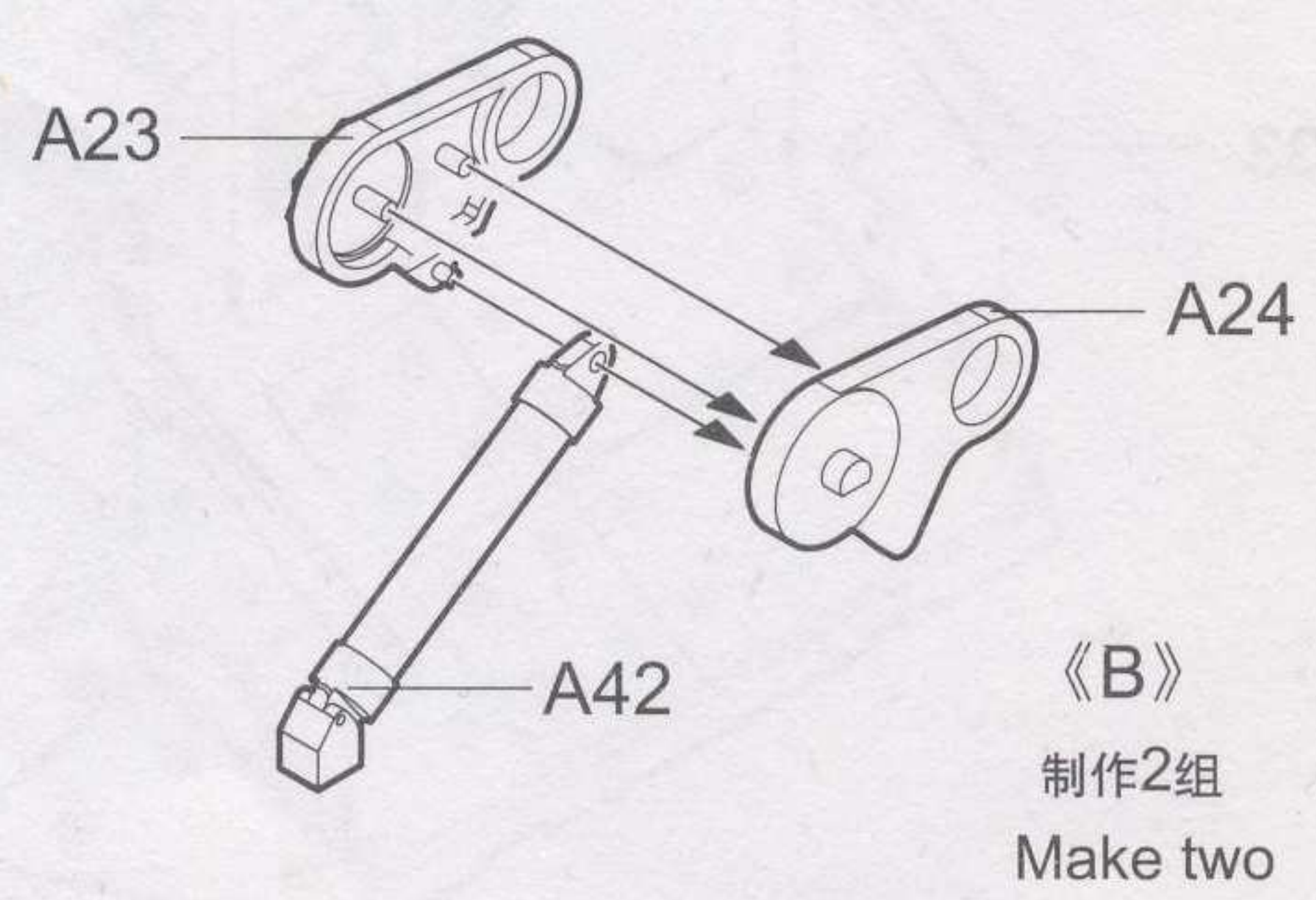
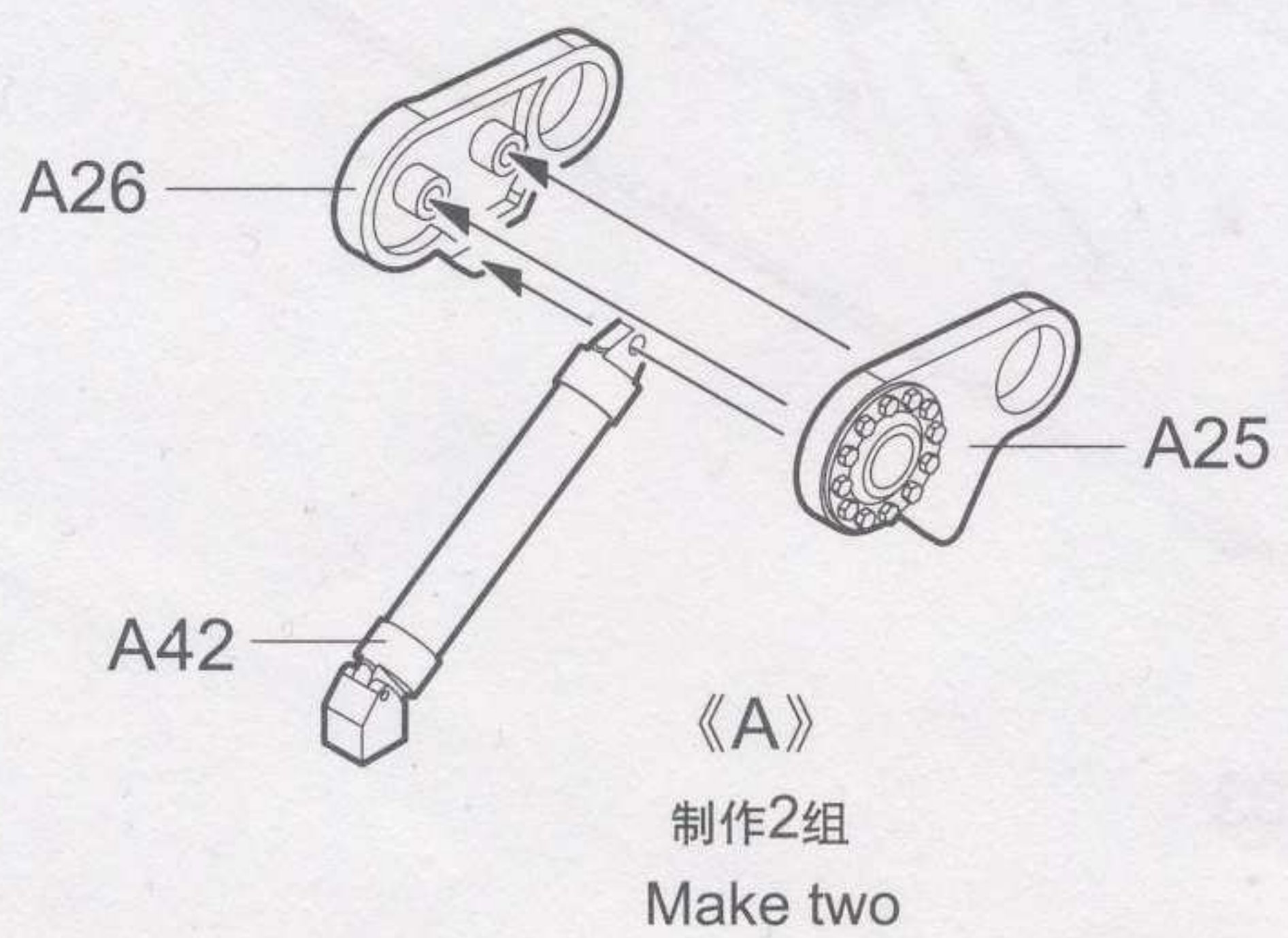
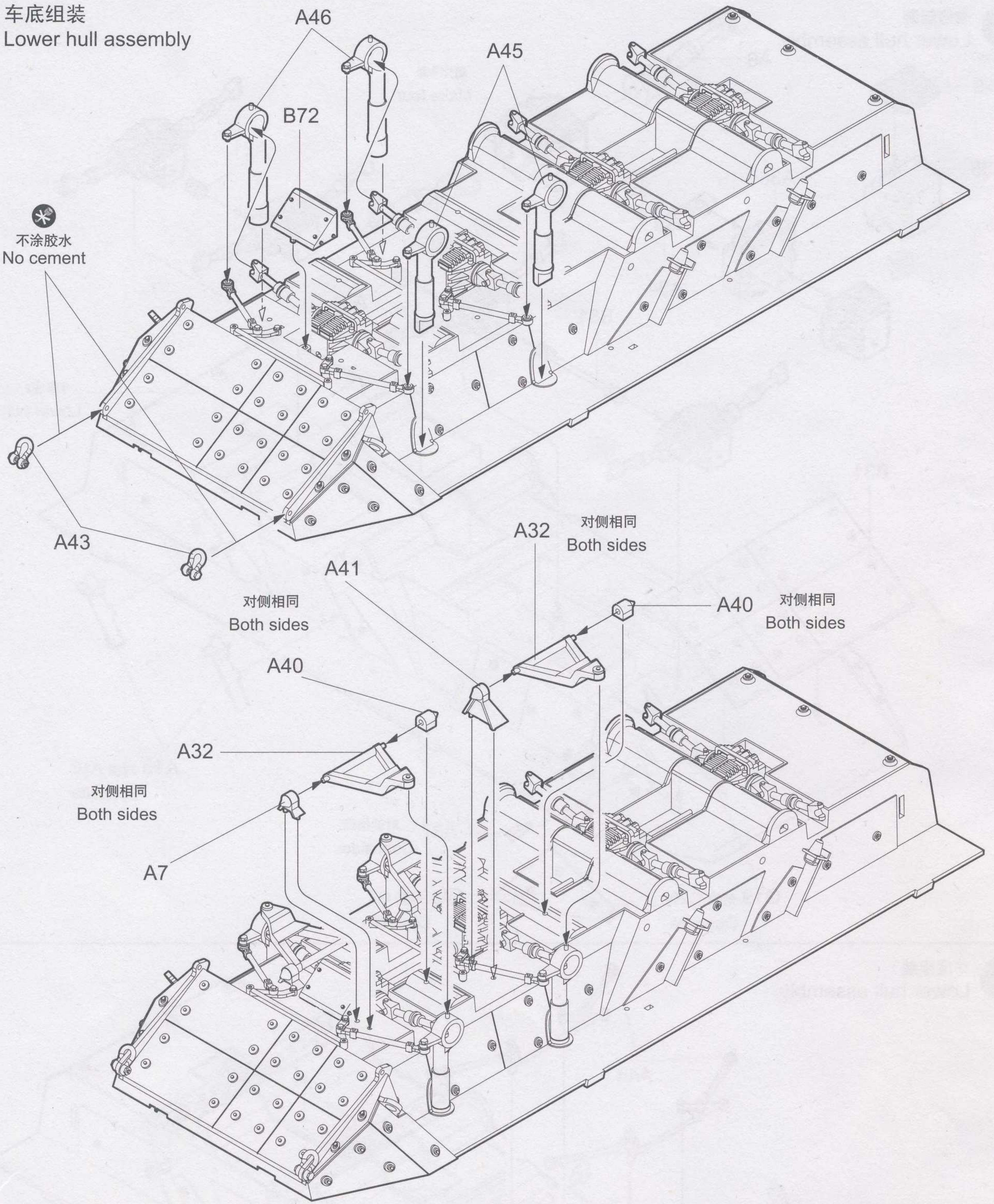

4

车底组装
Lower hull assembly

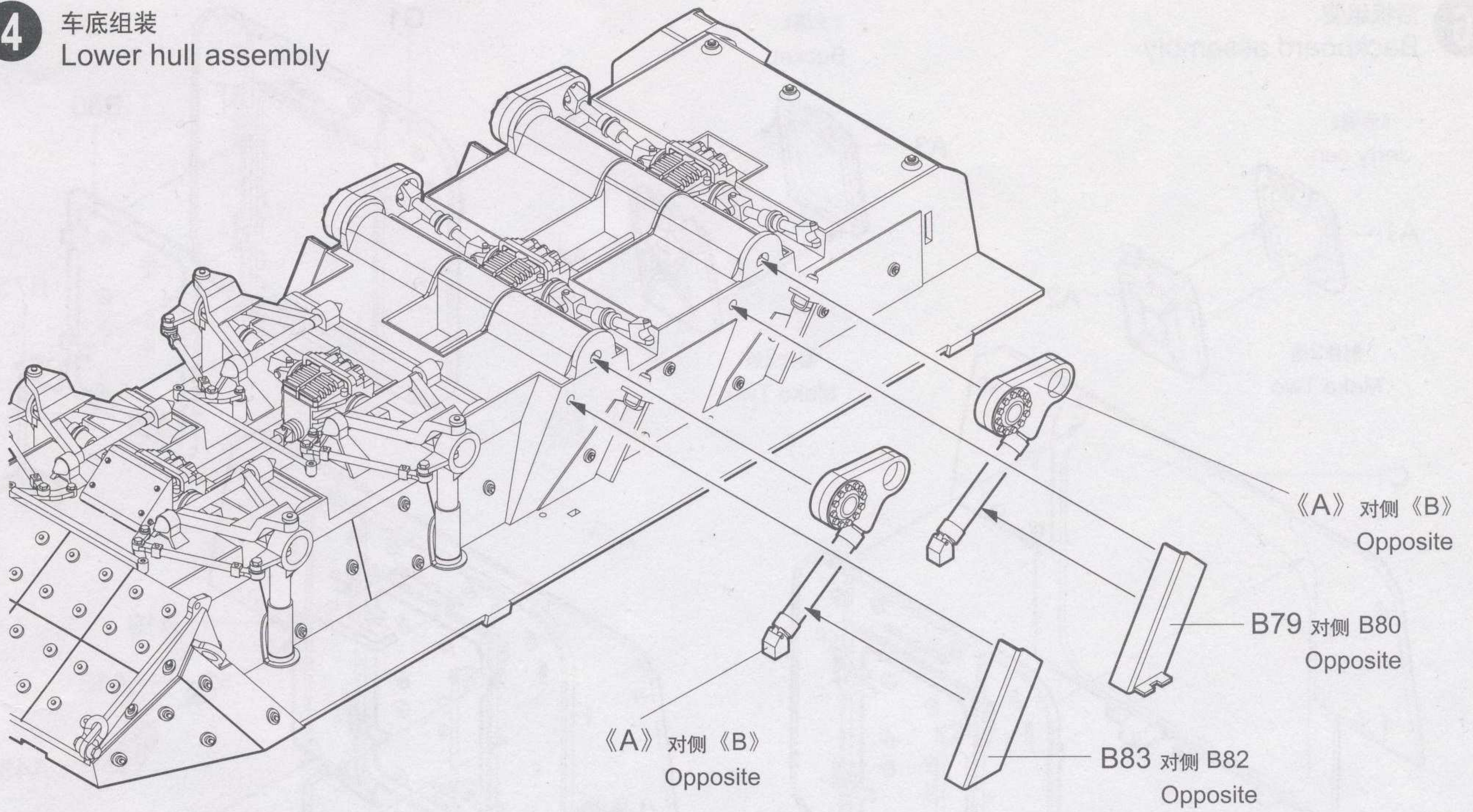

5

车轮安装
wheel installation

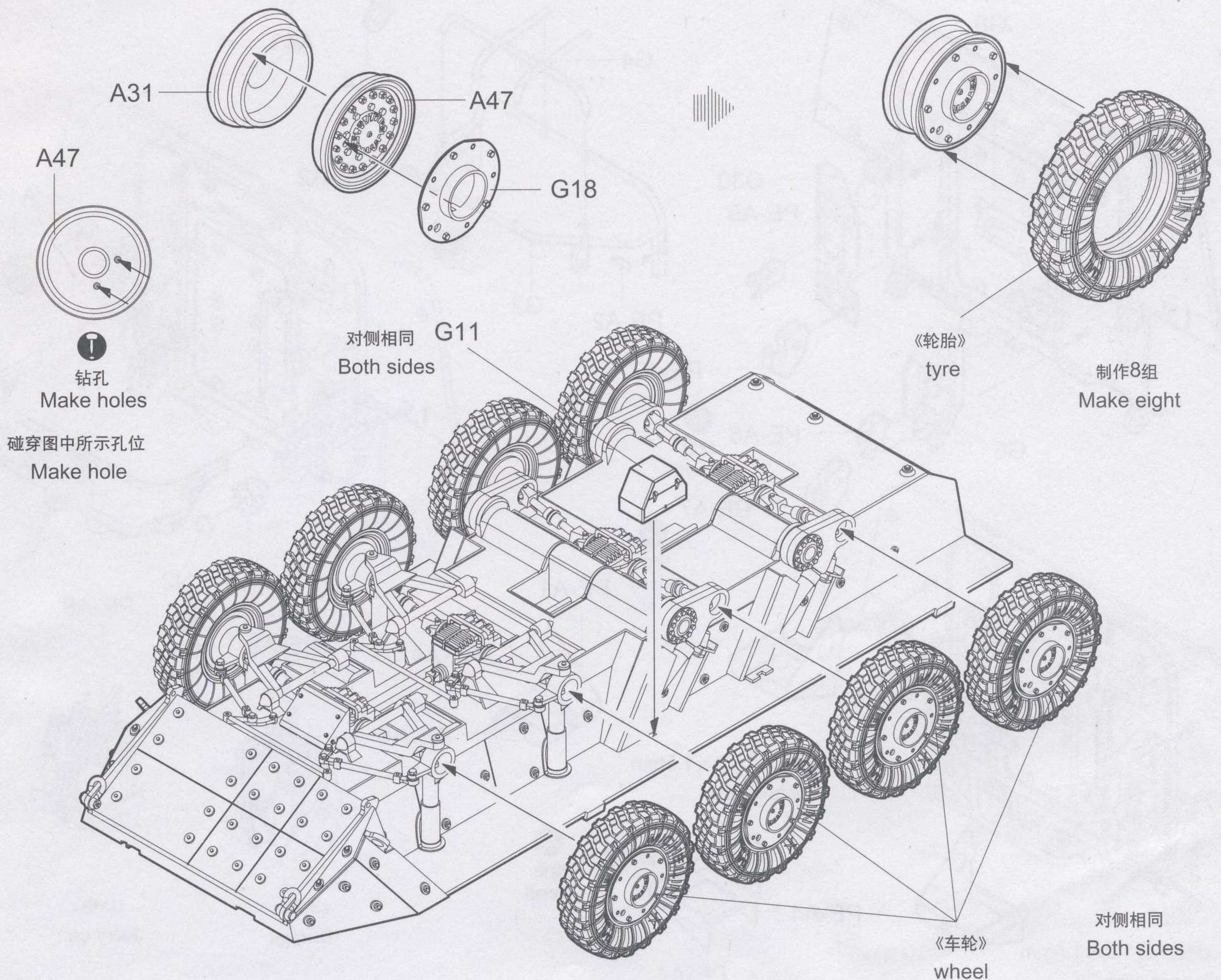

6

后板组装
Backboard assembly

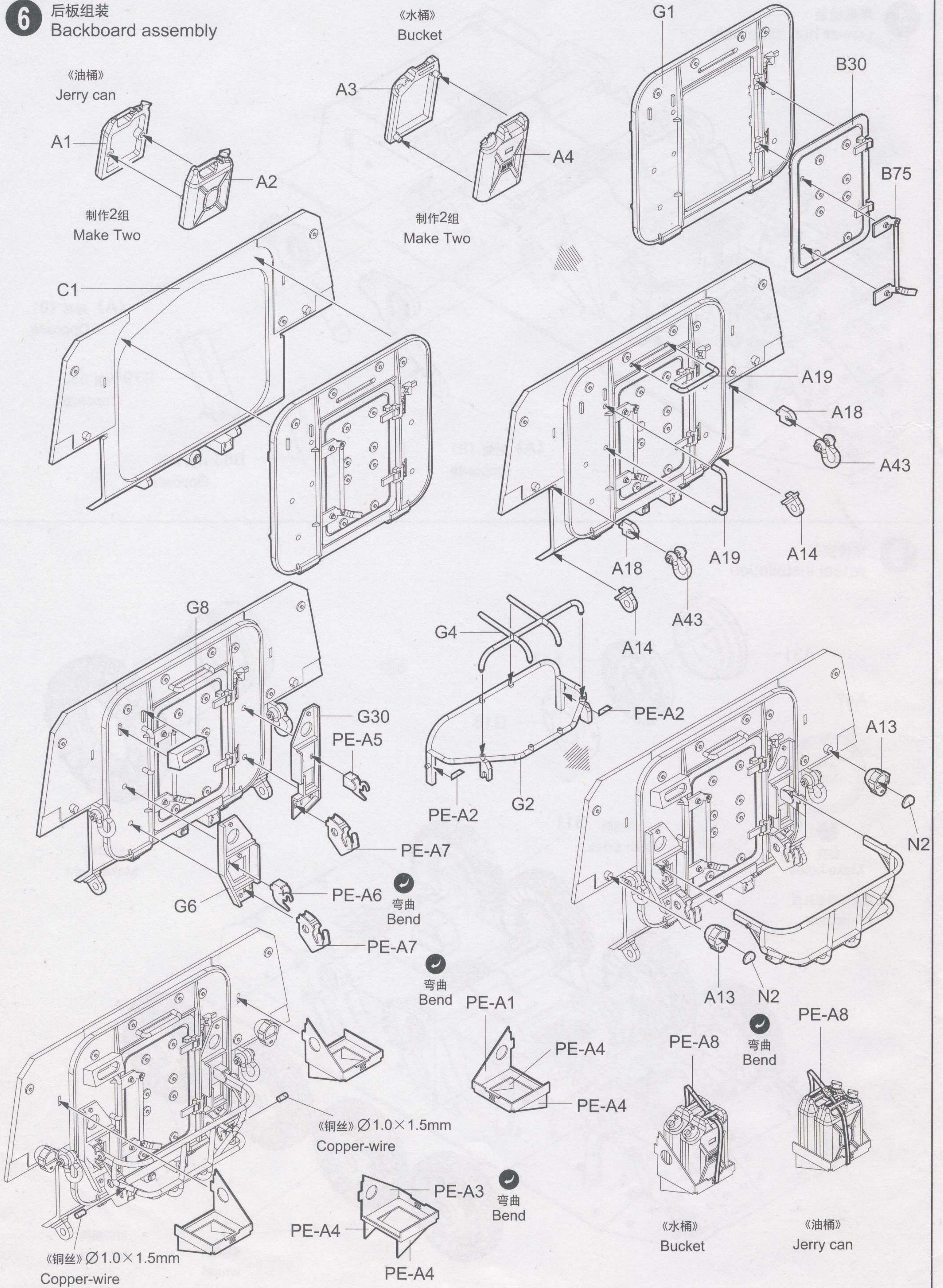

7 车底组装
Lower hull assembly

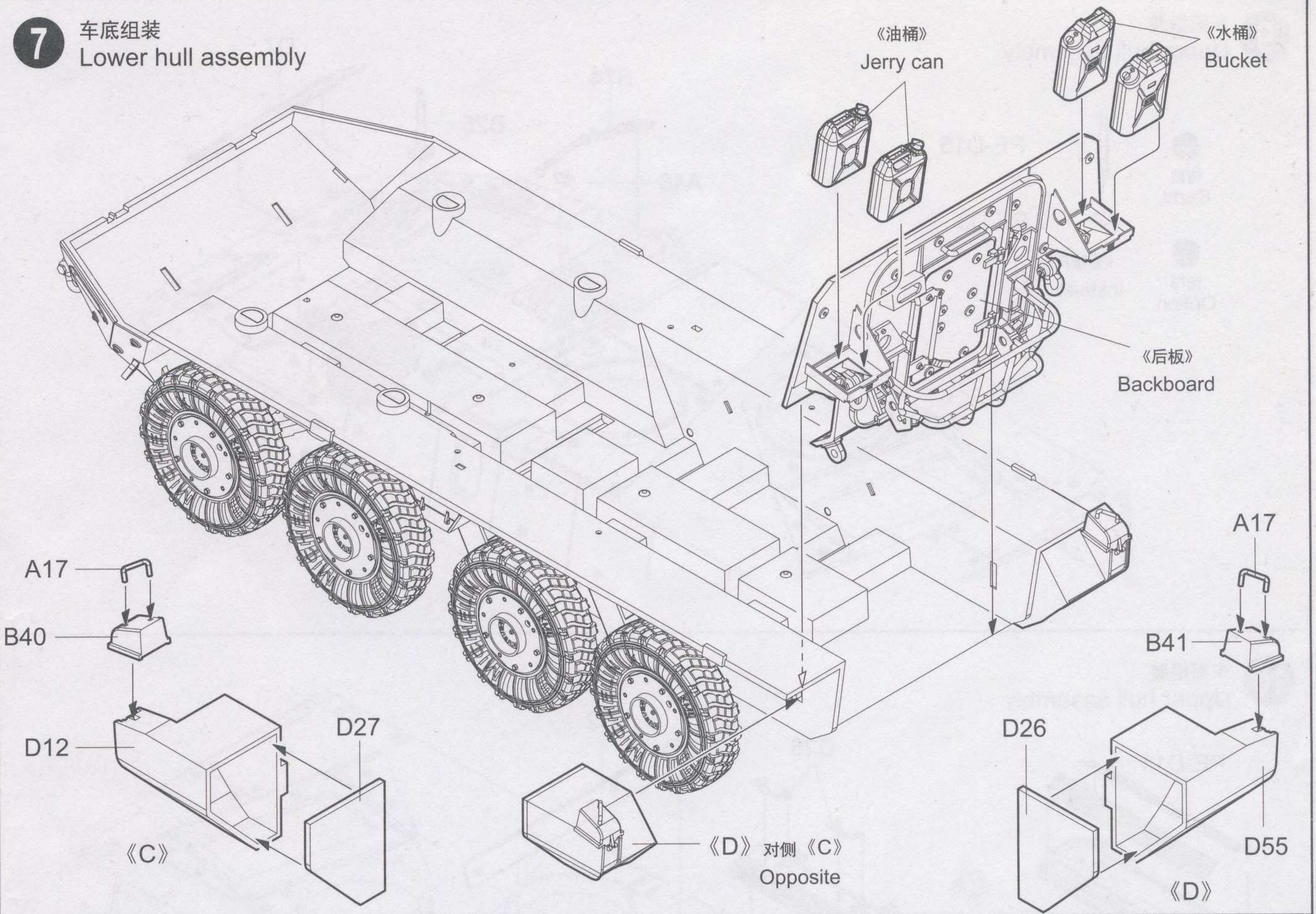

8 车面组装
Upper hull assembly

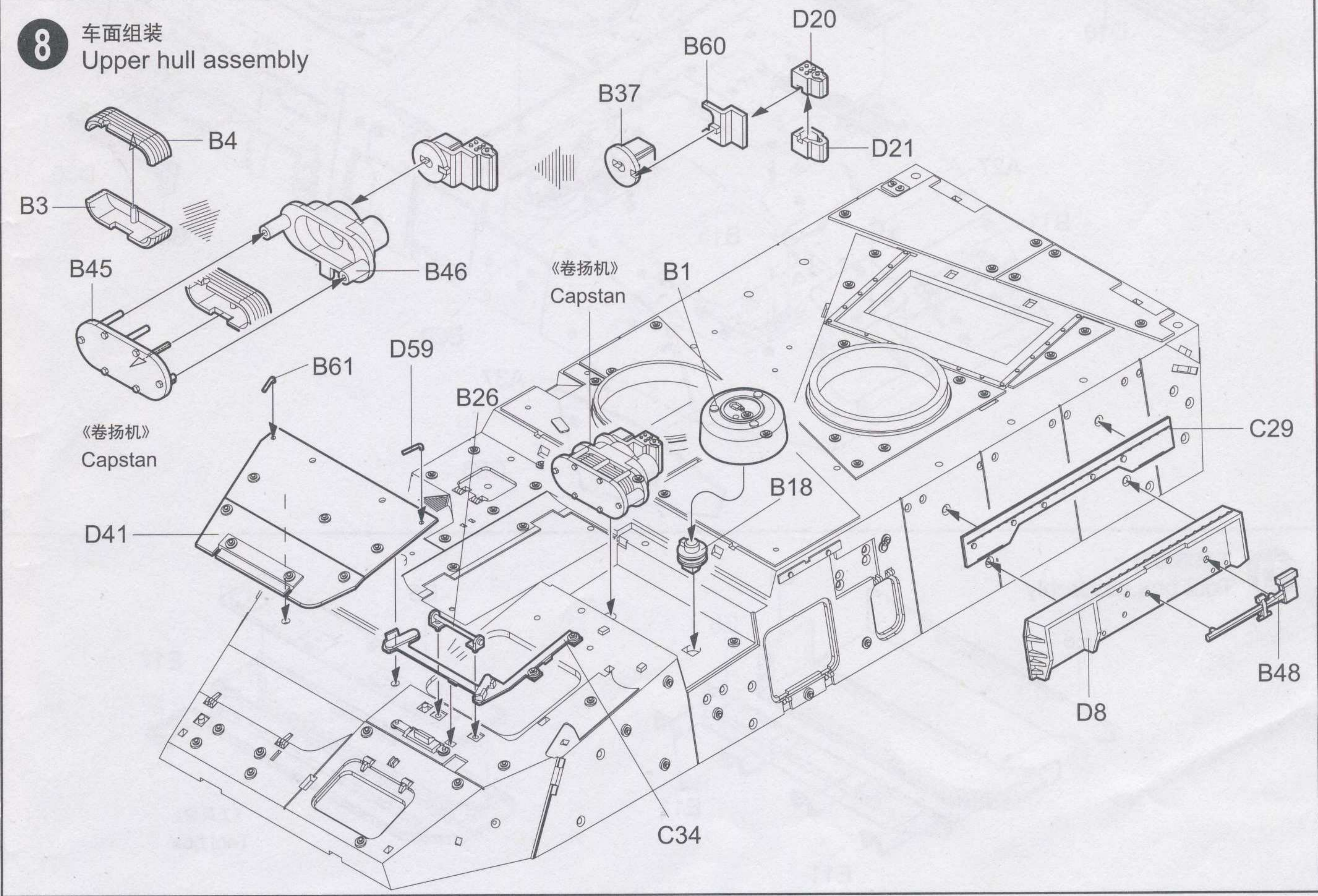

9 车面组装
Upper hull assembly

弯曲
Bend

选择
Option

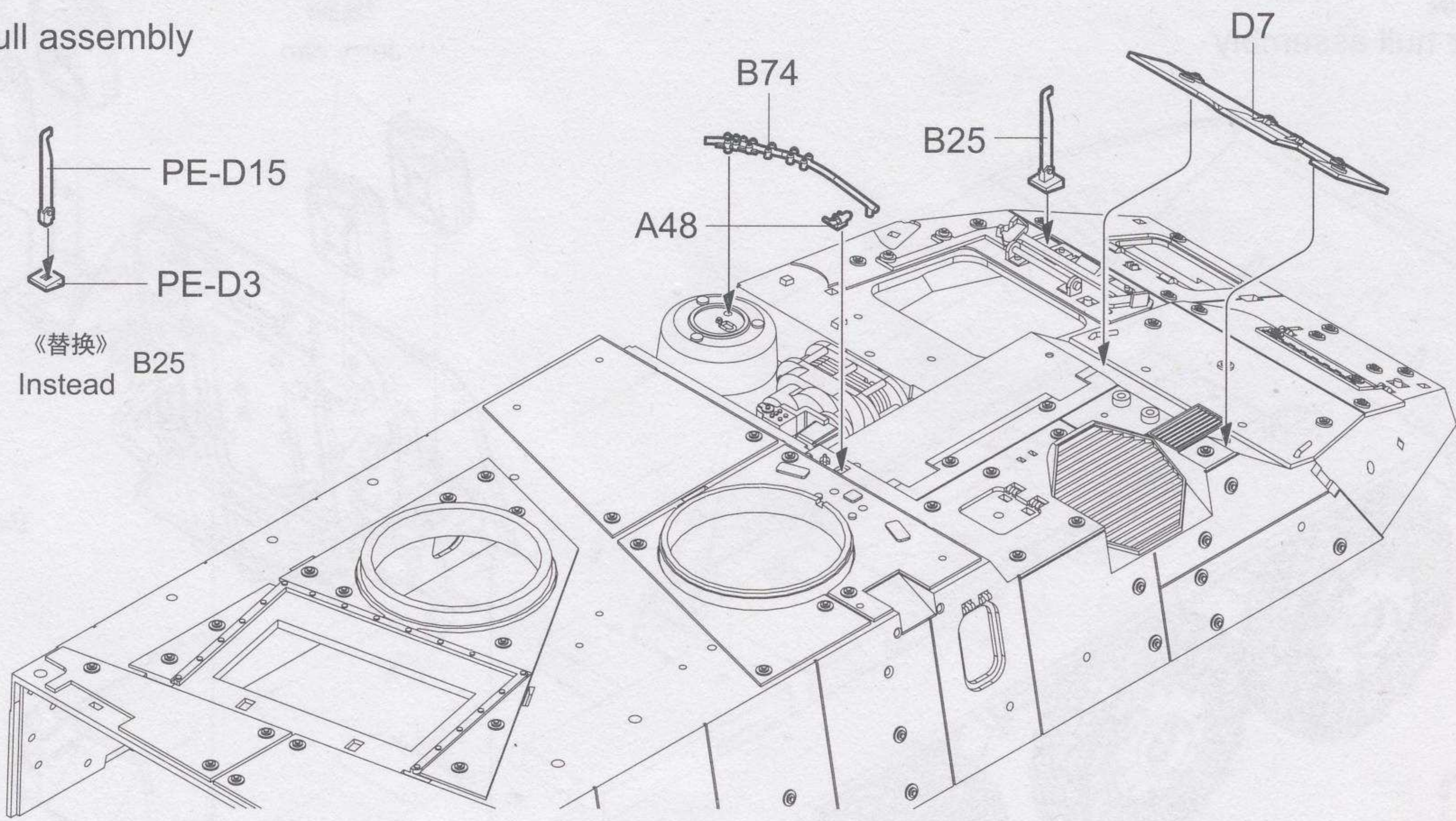

10 车面组装
Upper hull assembly

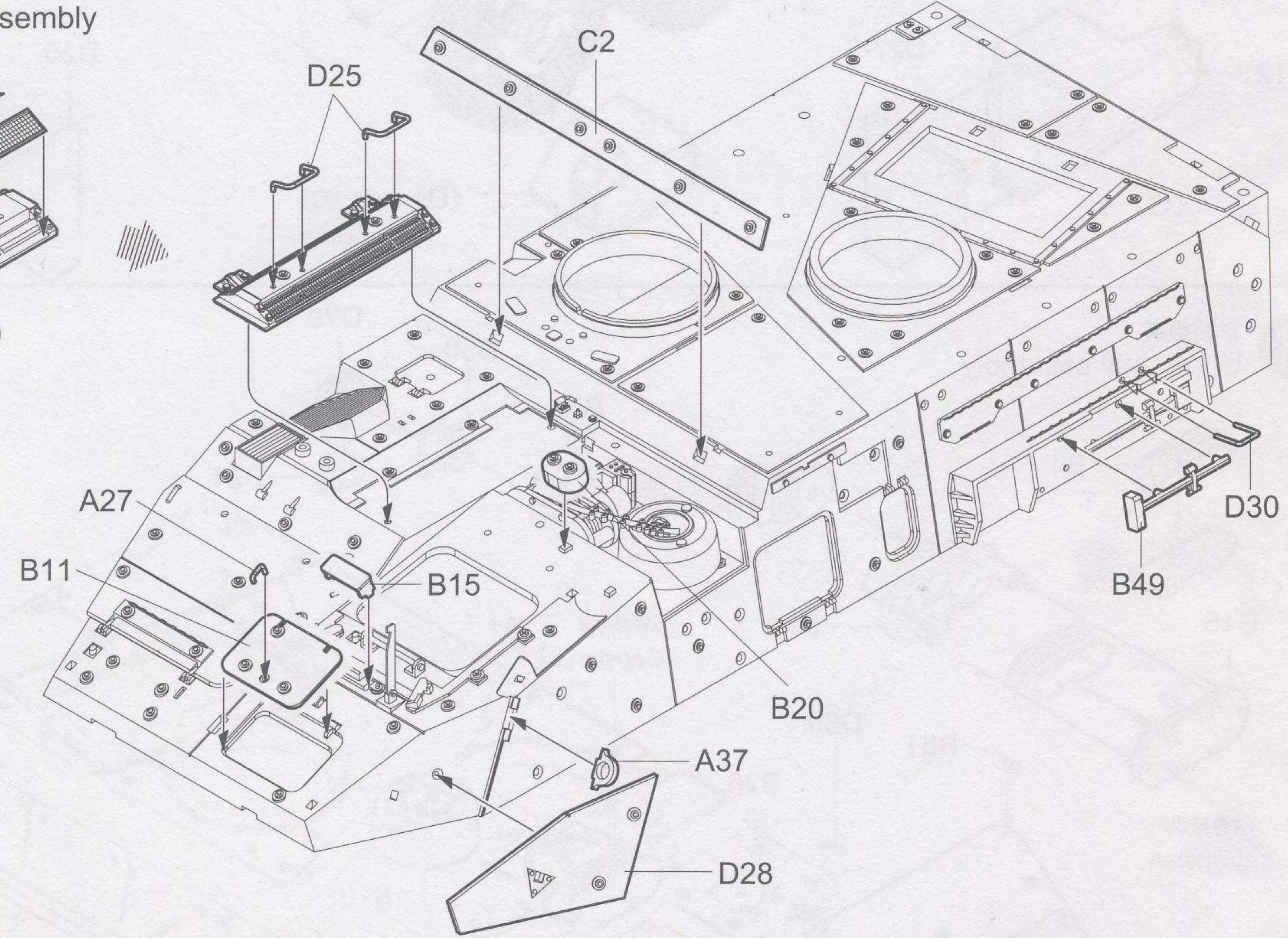
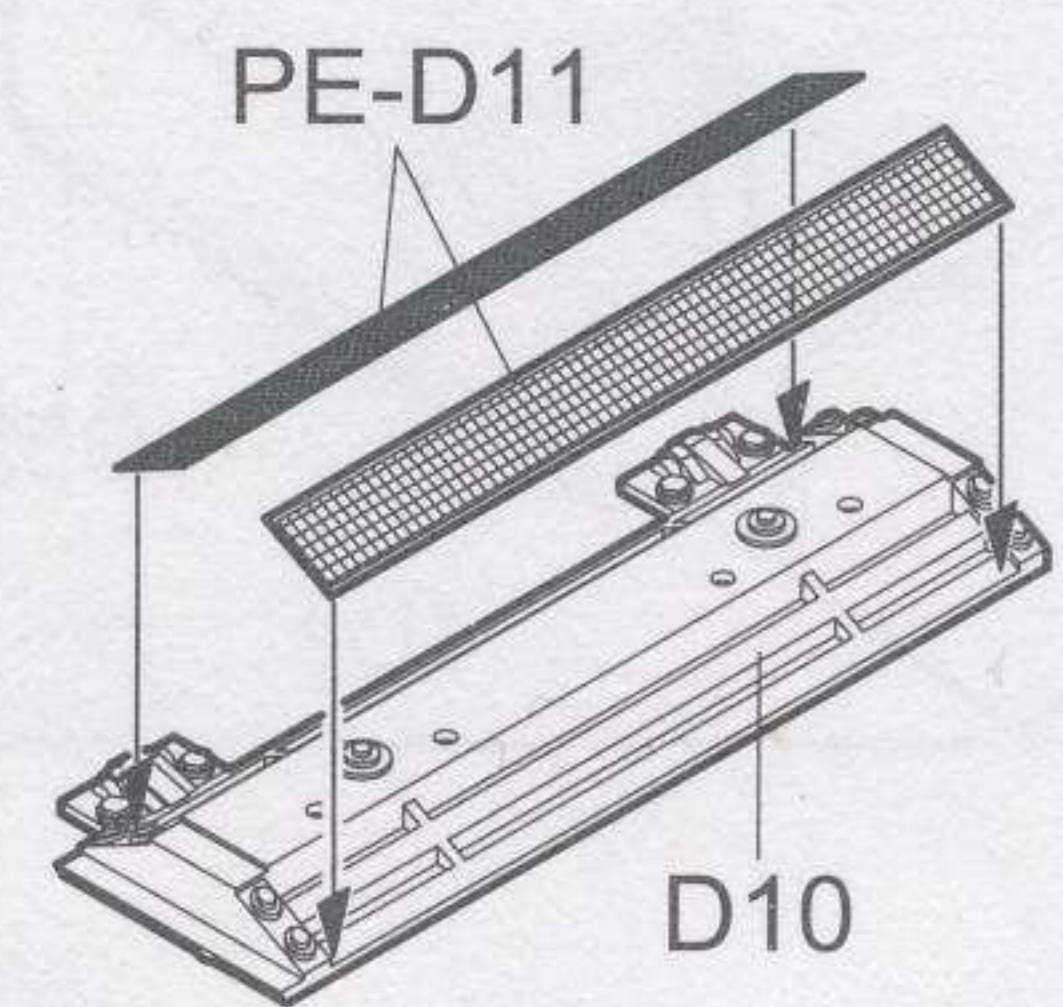

11 工具箱组装
Tool box assembly

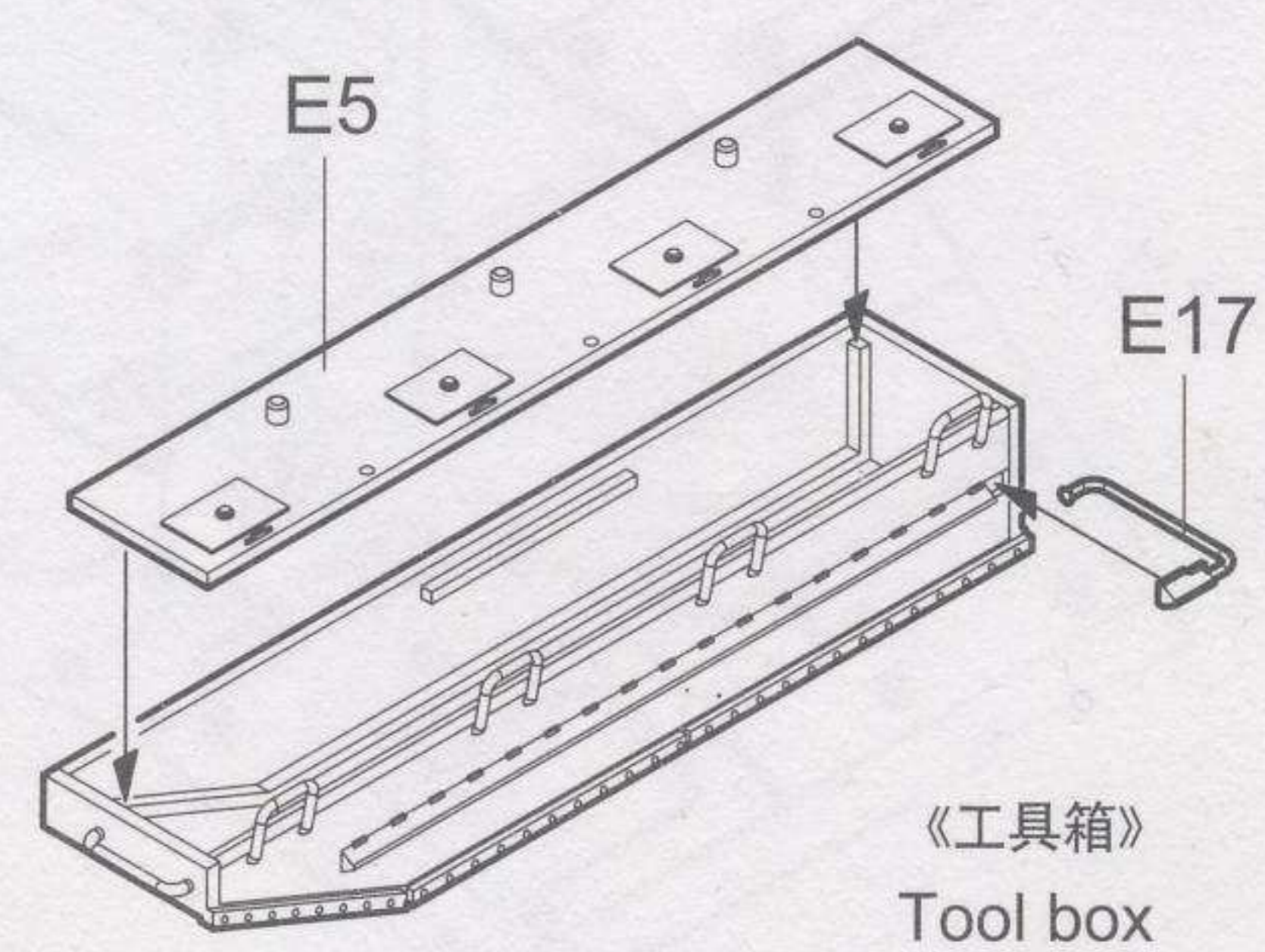
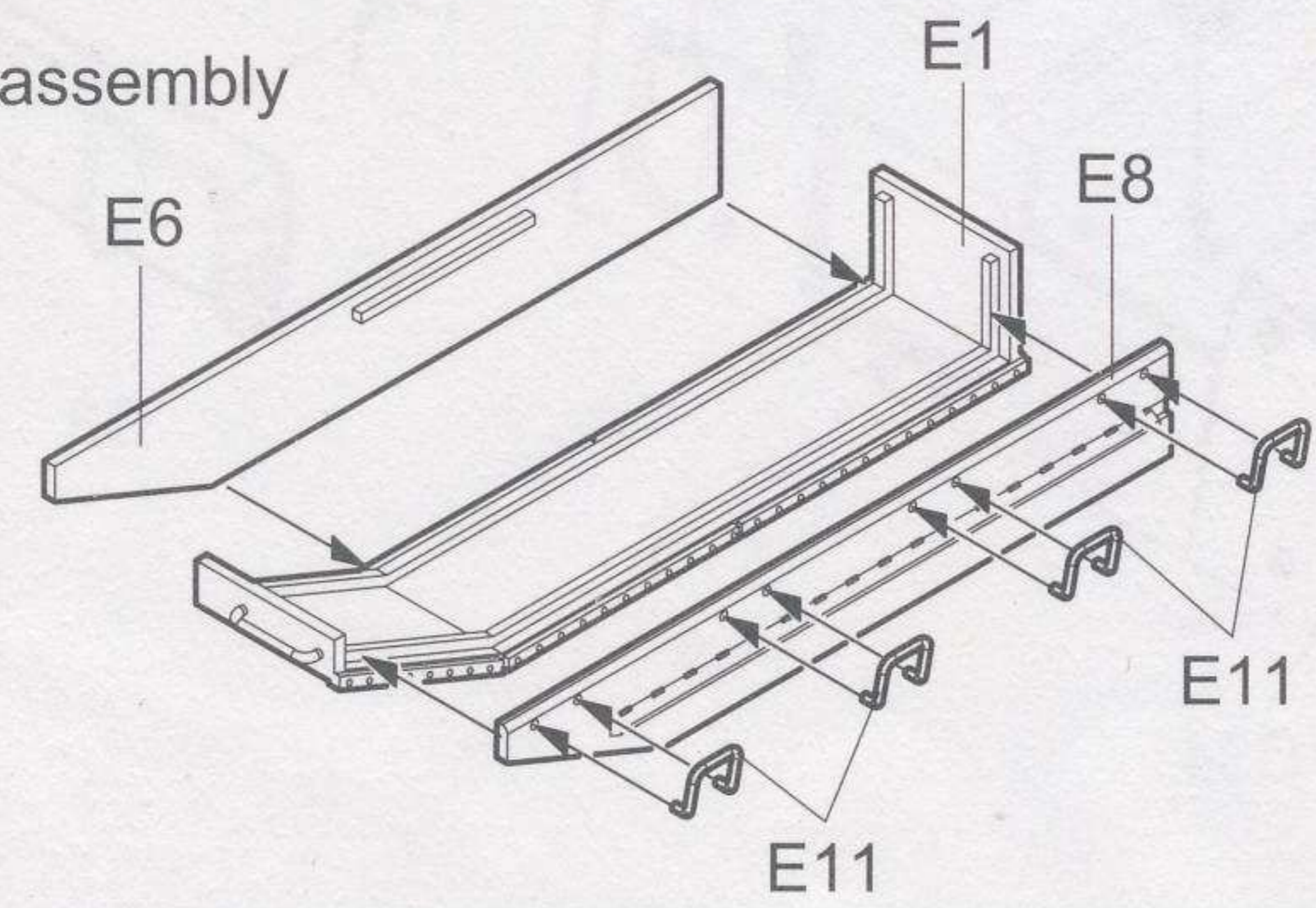

《工具箱》
Tool box

12 车面组装
Upper hull assembly

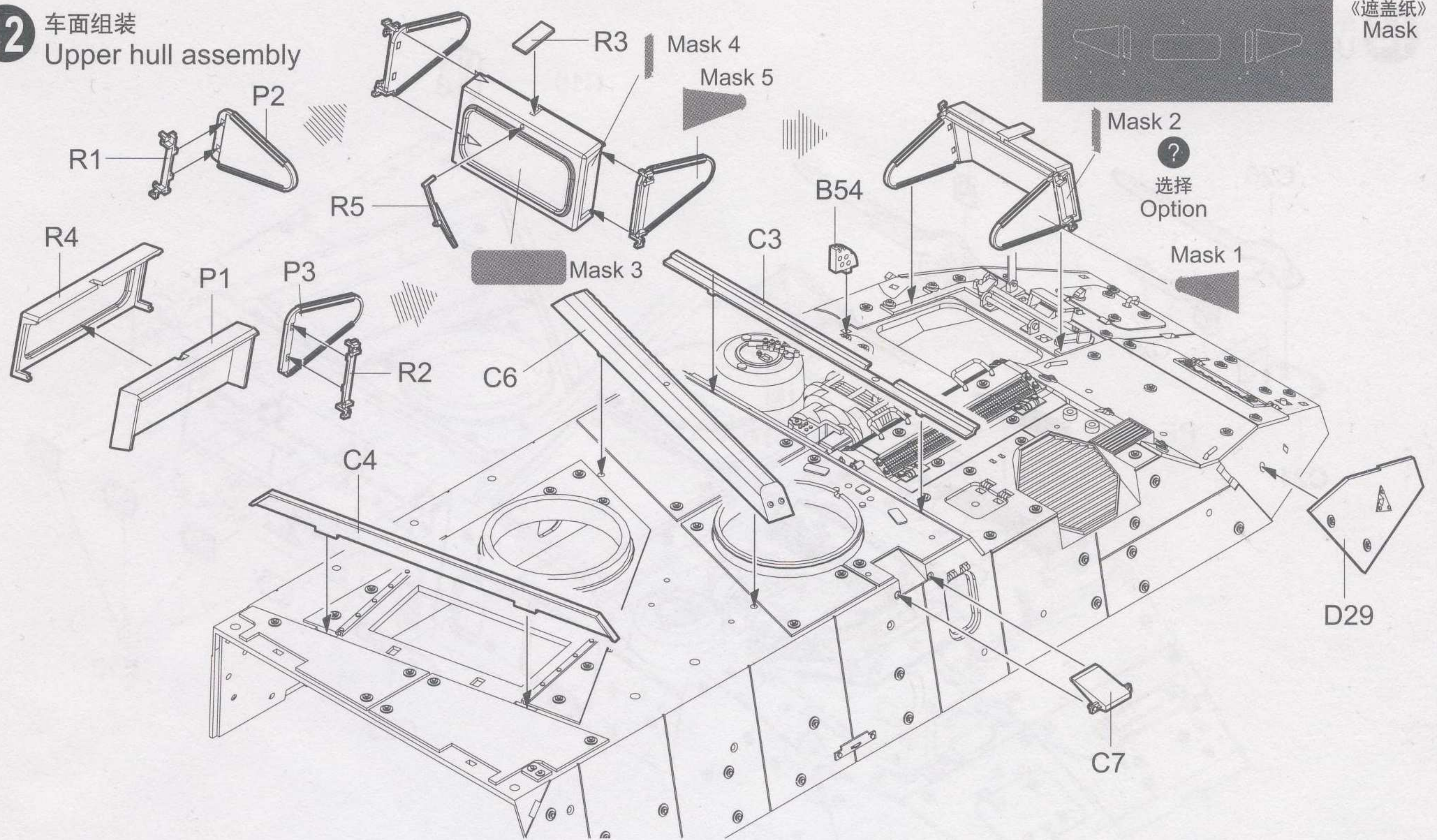

13 车面组装
Upper hull assembly

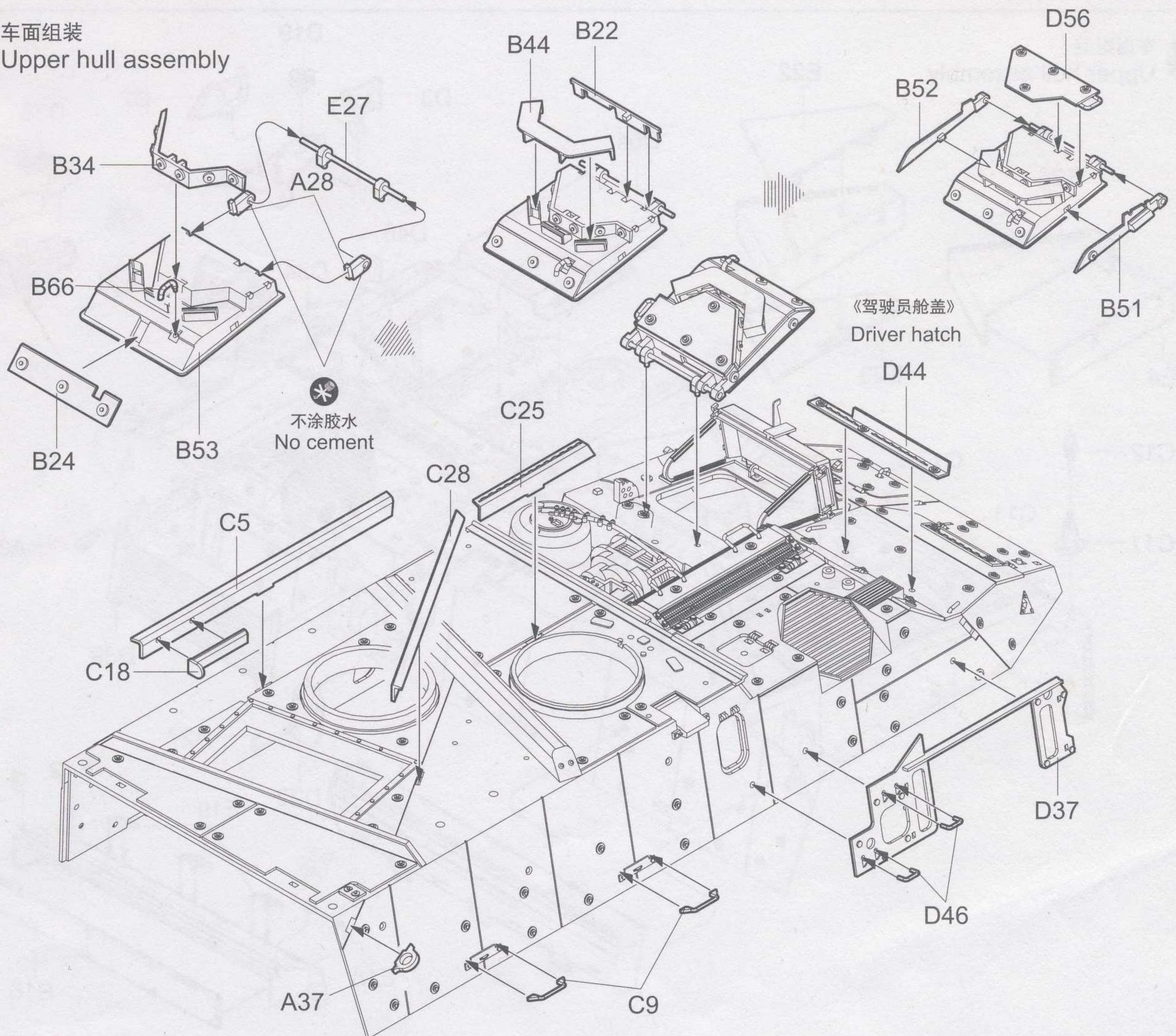

14 车面组装
Upper hull assembly

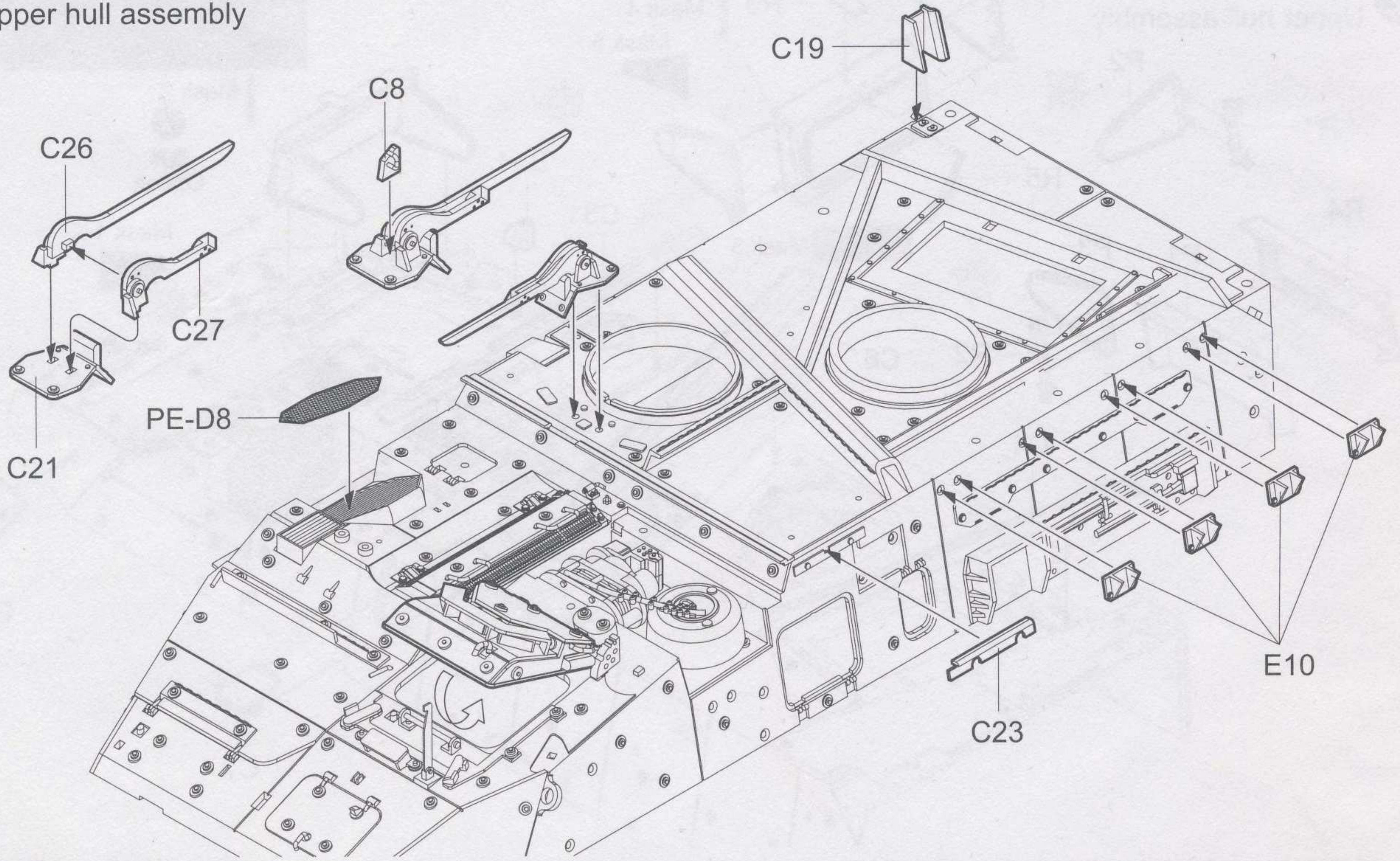

15 车面组装
Upper hull assembly

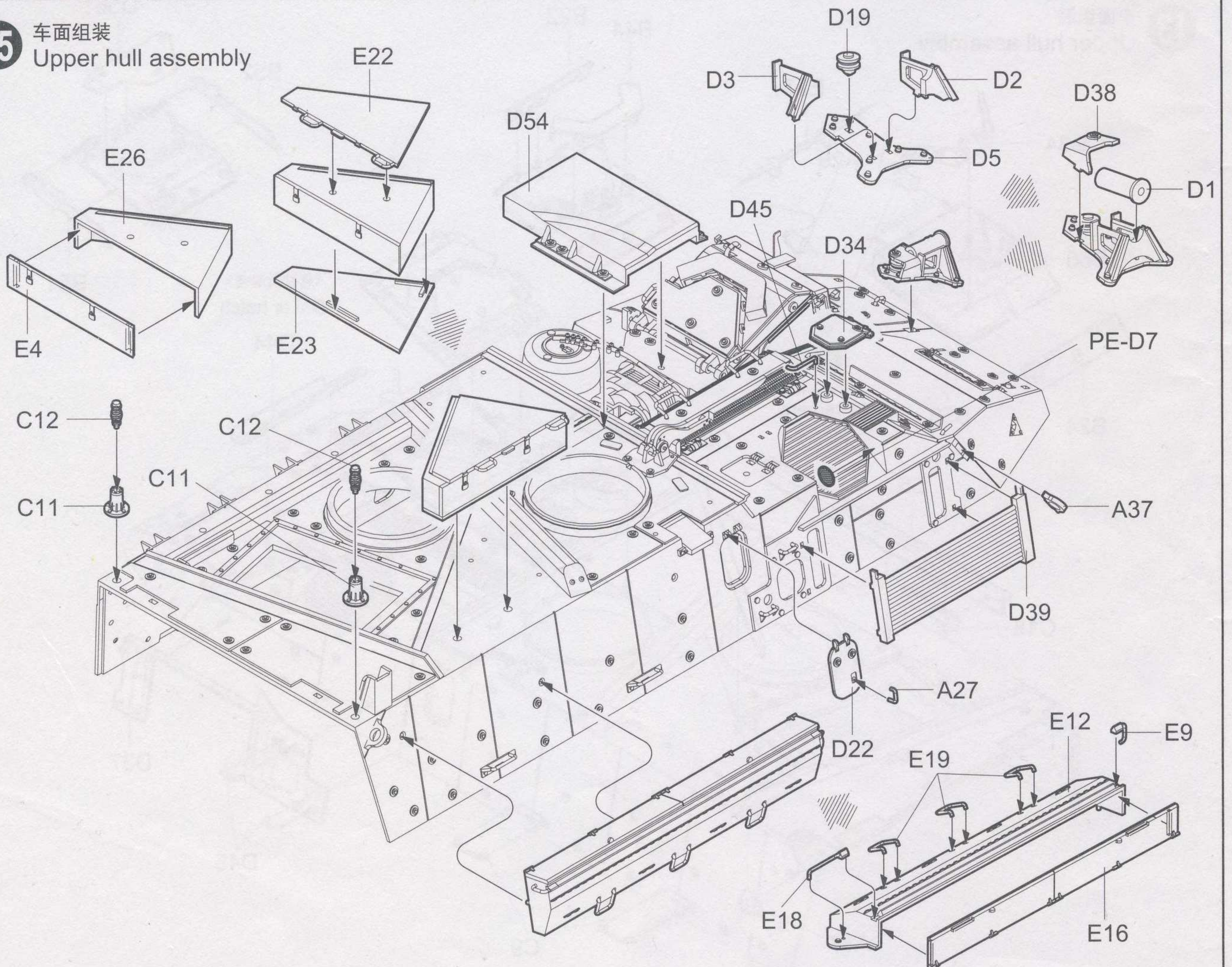

16 车灯组装
Head light assembly

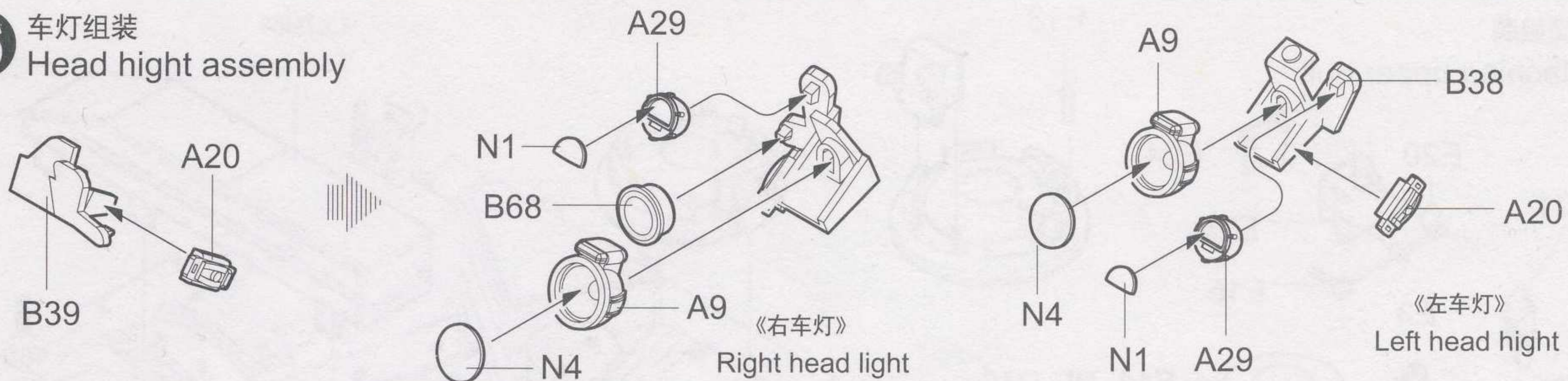

17 车面组装
Upper hull assembly

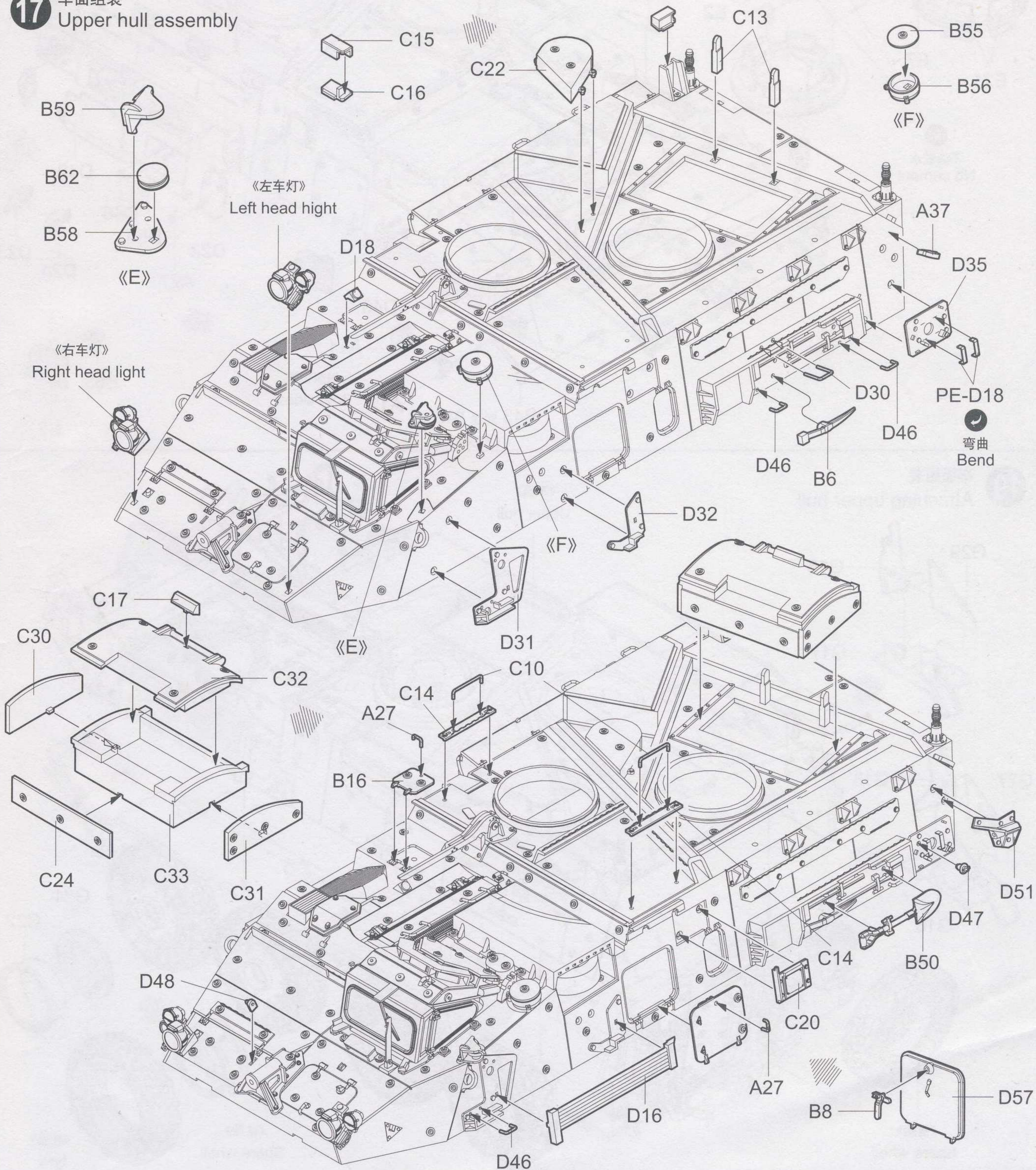

18

车面组装
Attaching upper hull

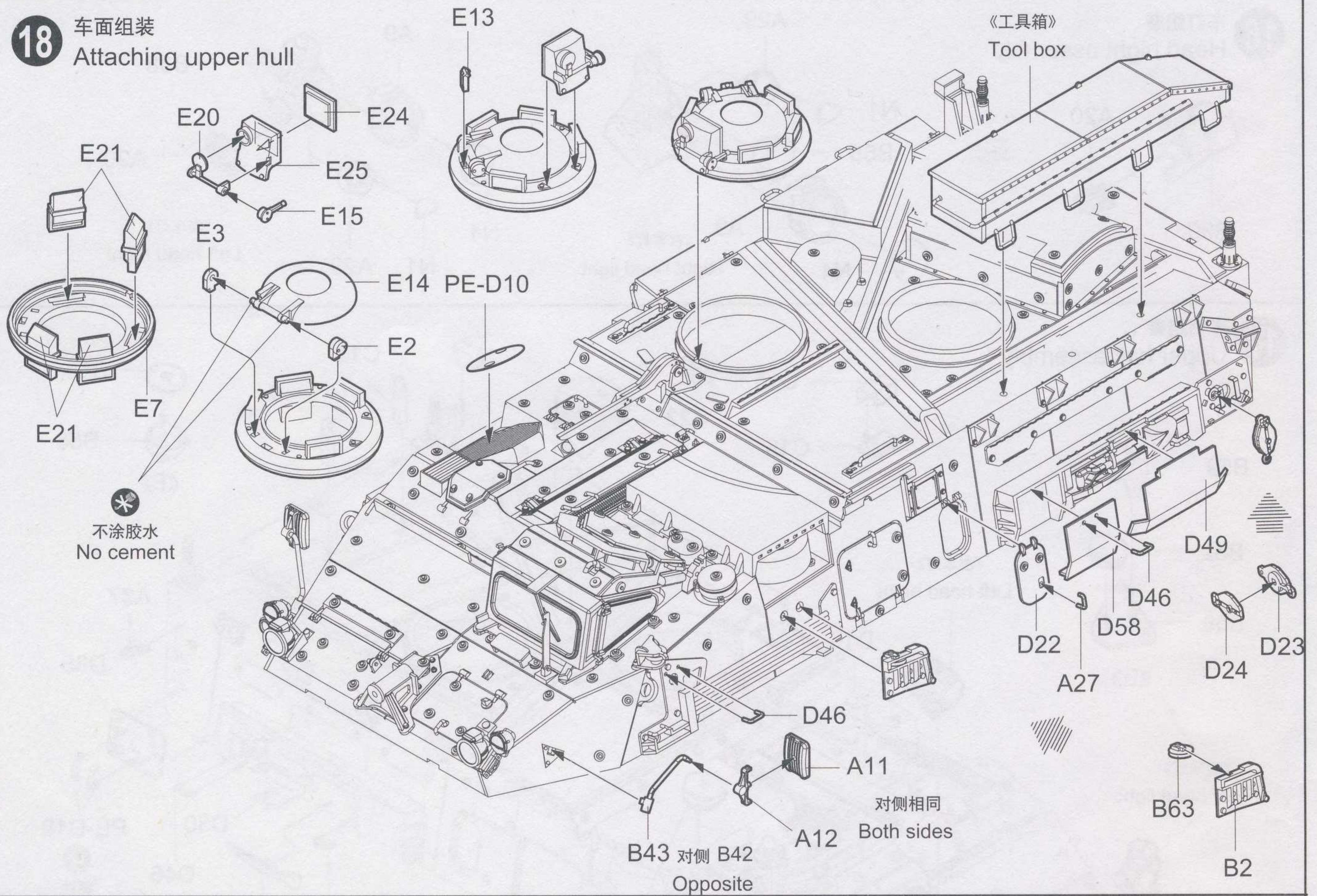

19

车面组装
Attaching upper hull

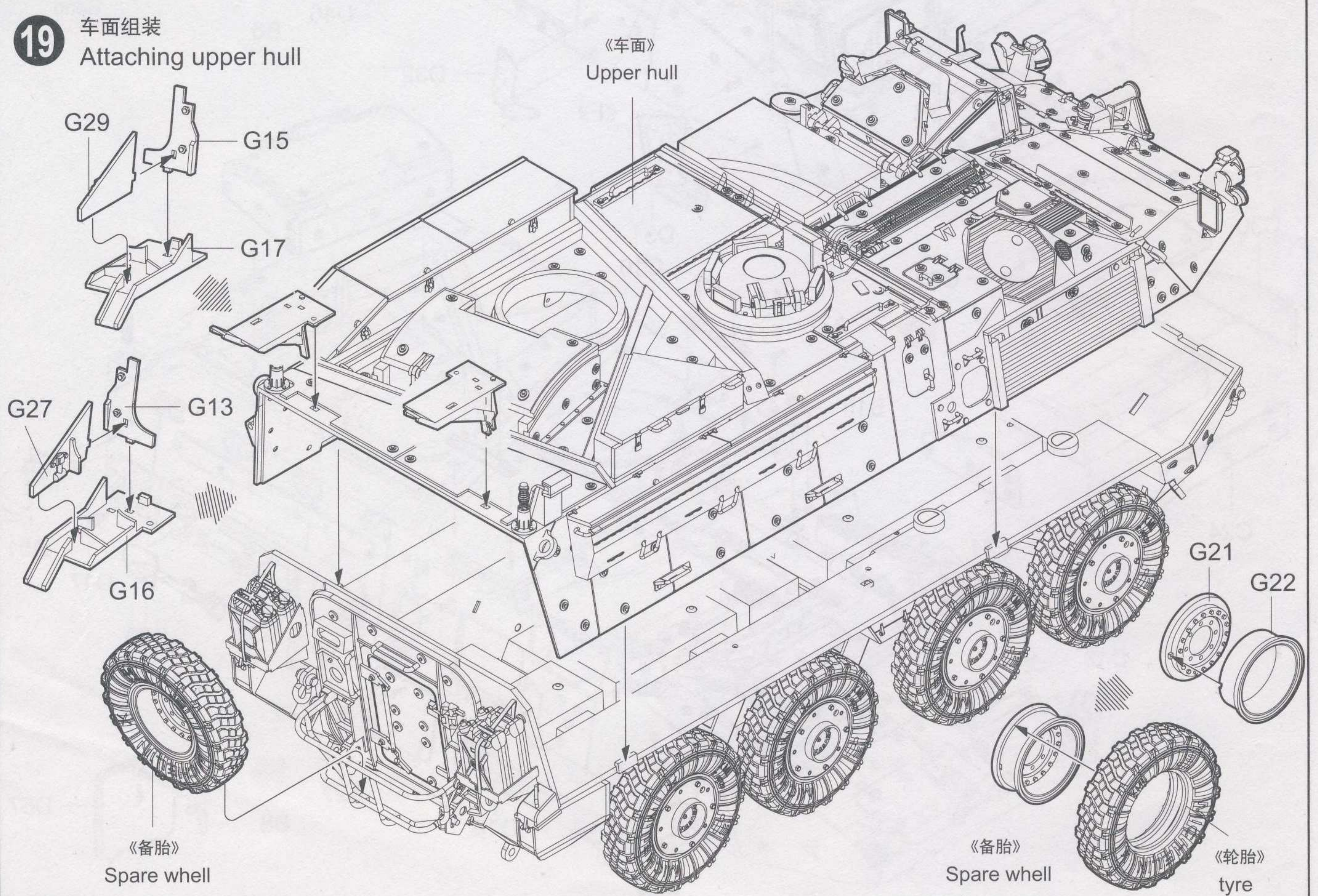

20 车面组装
Upper hull assembly

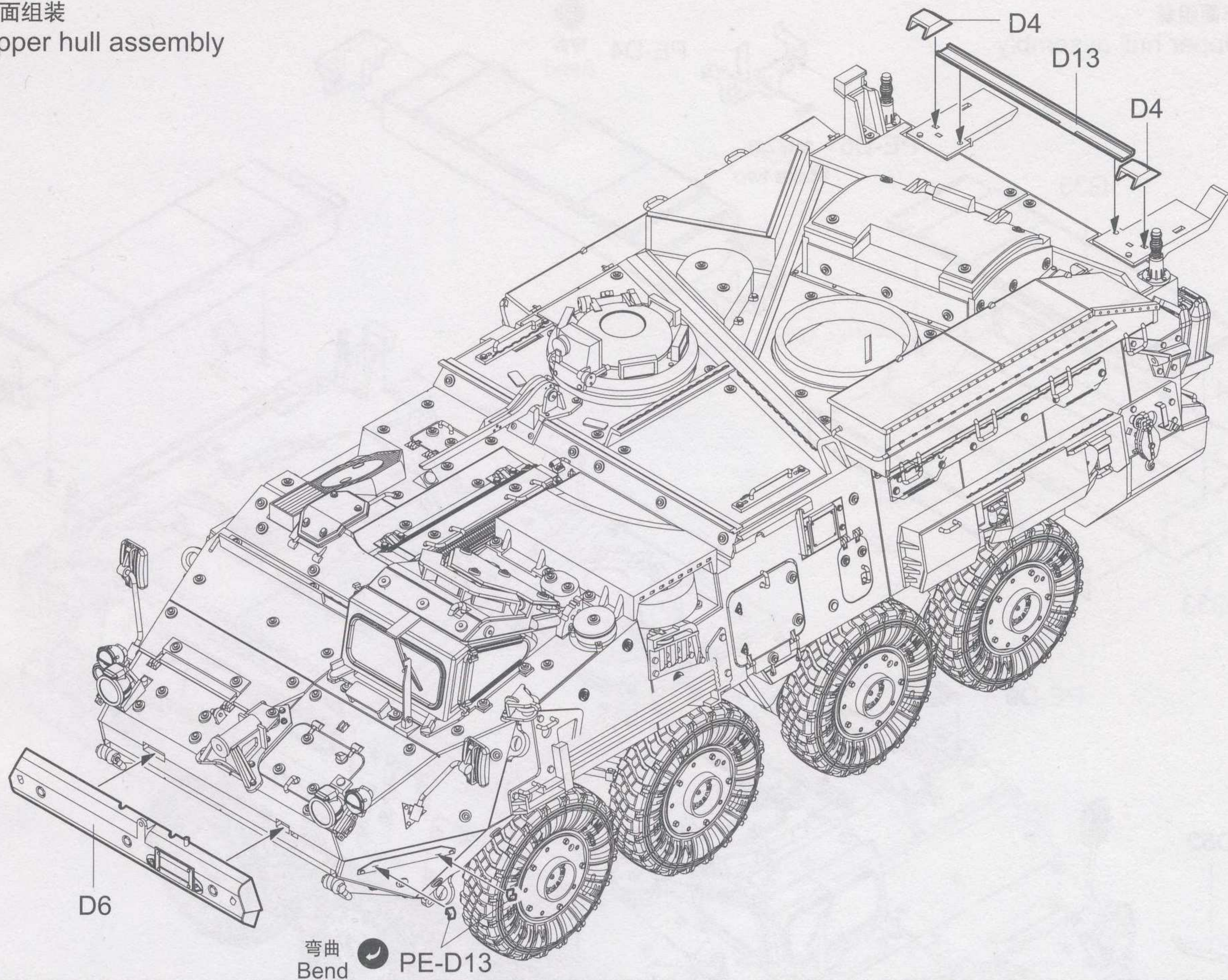

21 车面组装
Upper hull assembly

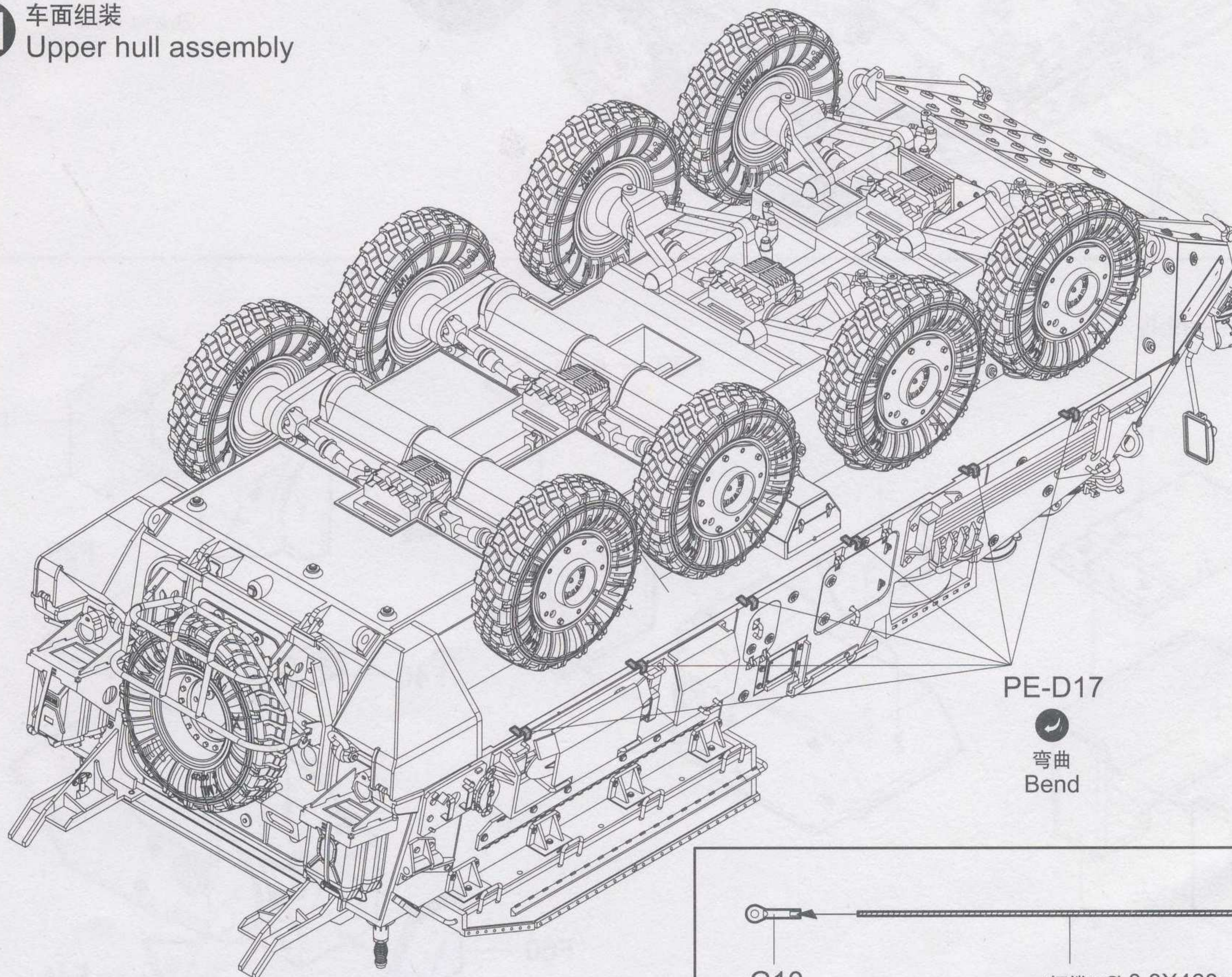

22 车面组装
Upper hull assembly

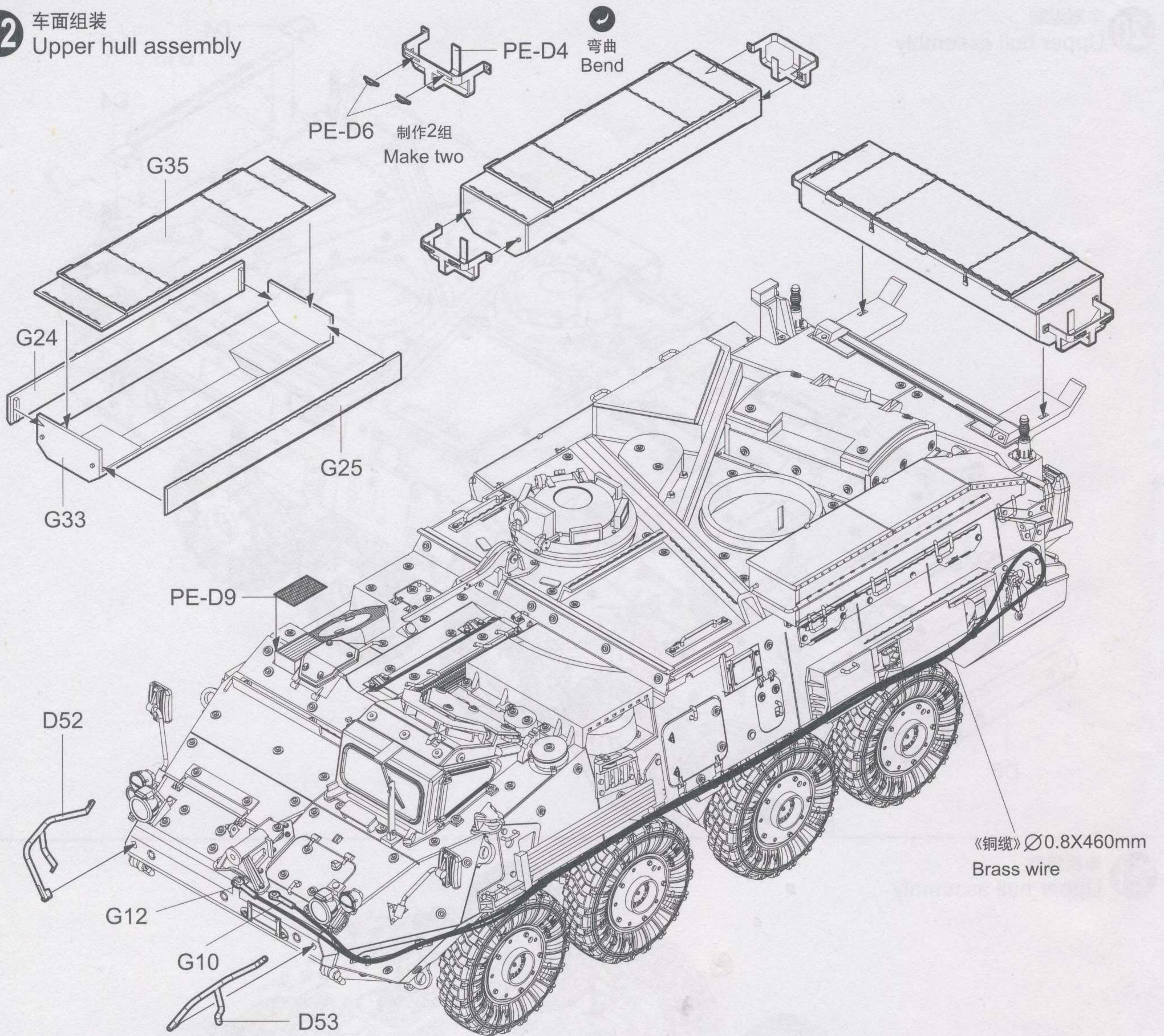

23 发射器组装
Launcher assembly

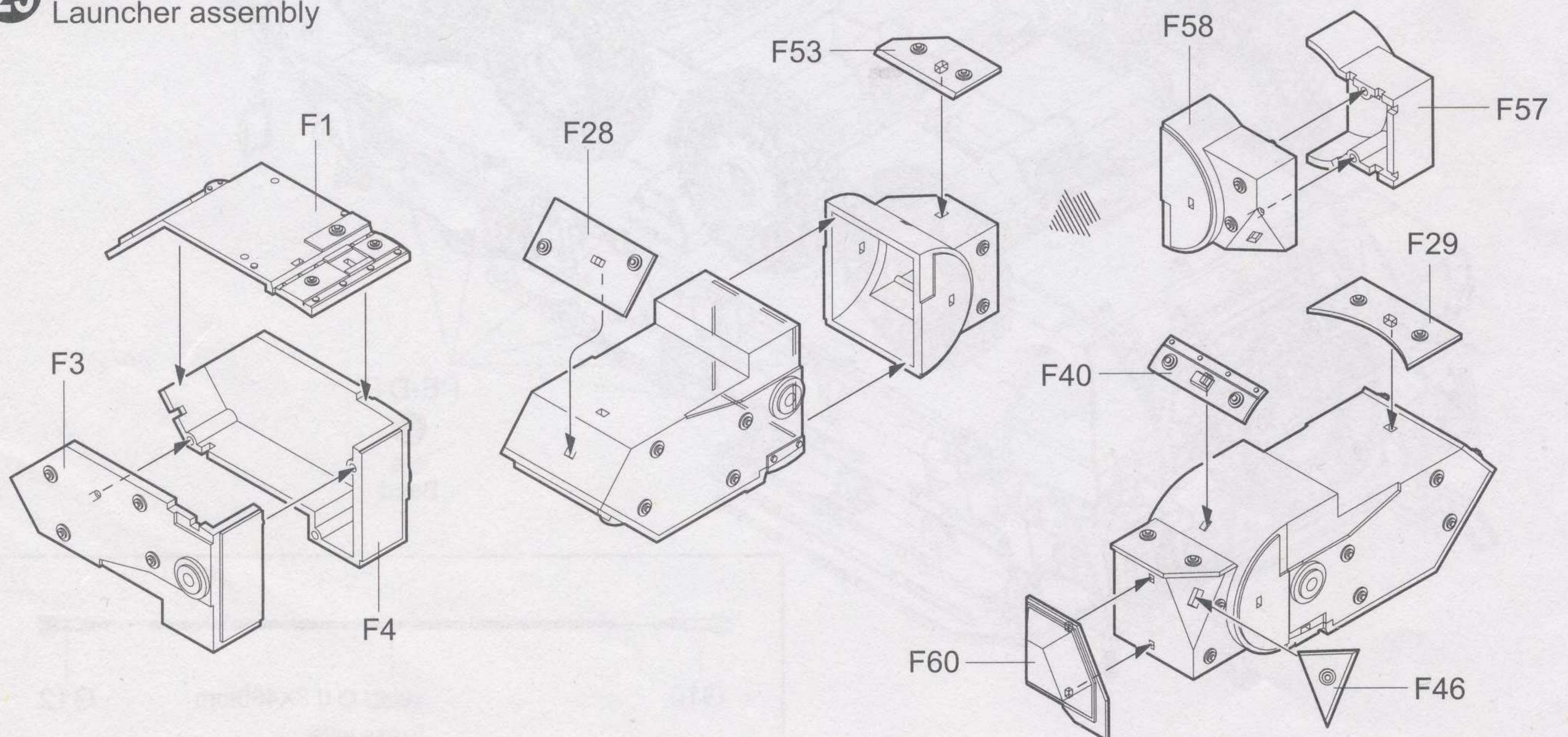

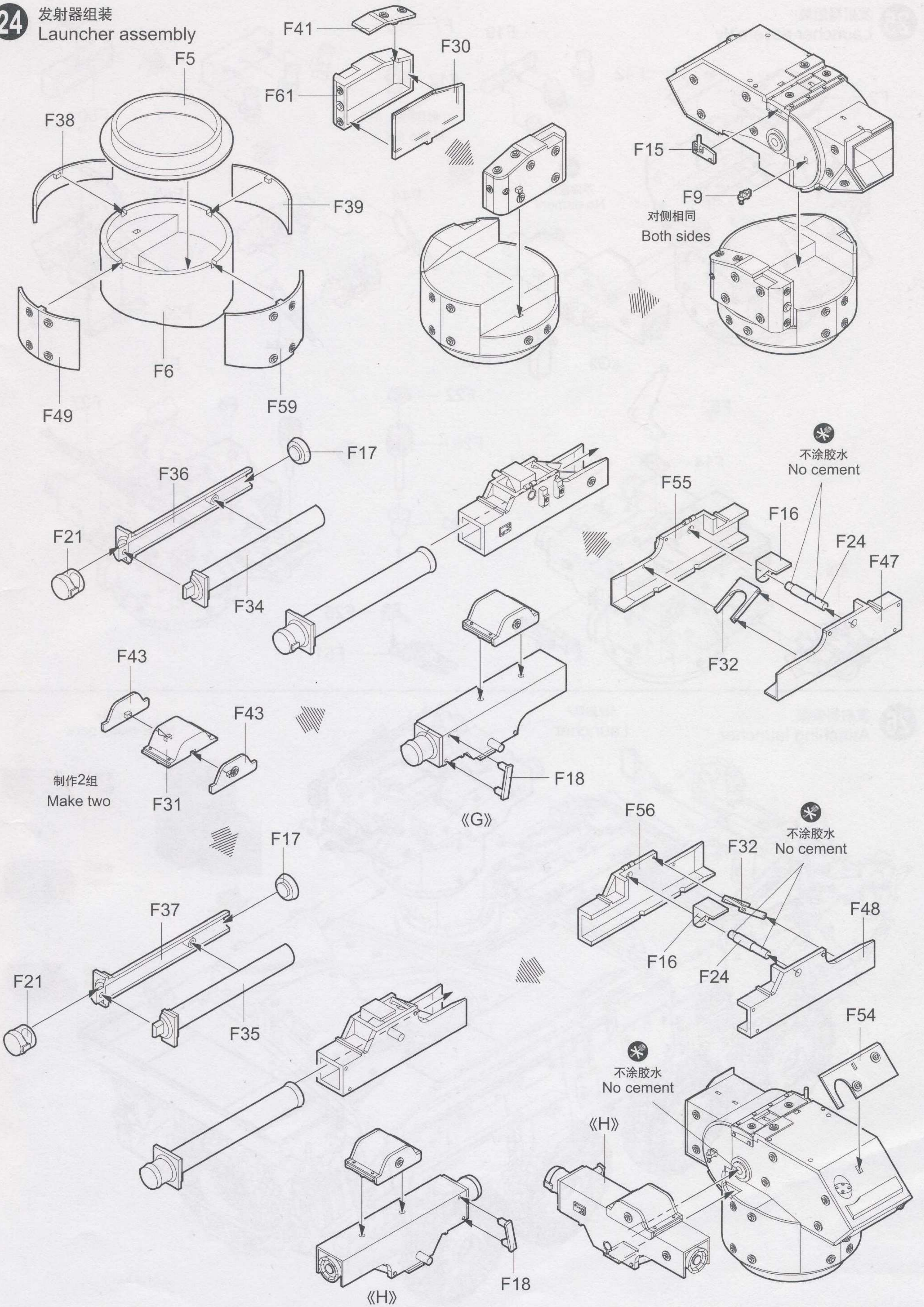

25 发射器组装
Launcher assembly

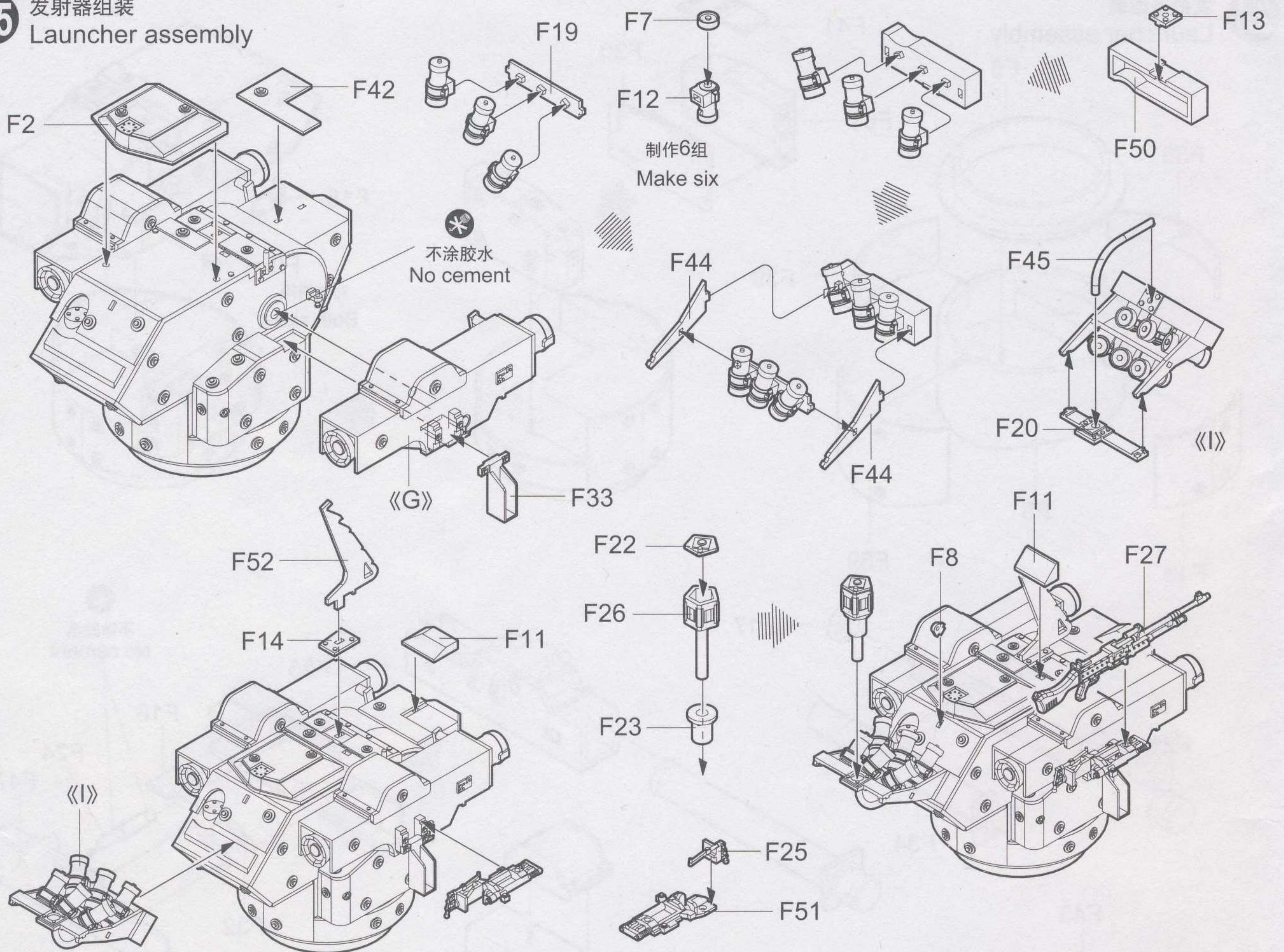

26 发射器安装
Attaching launcher

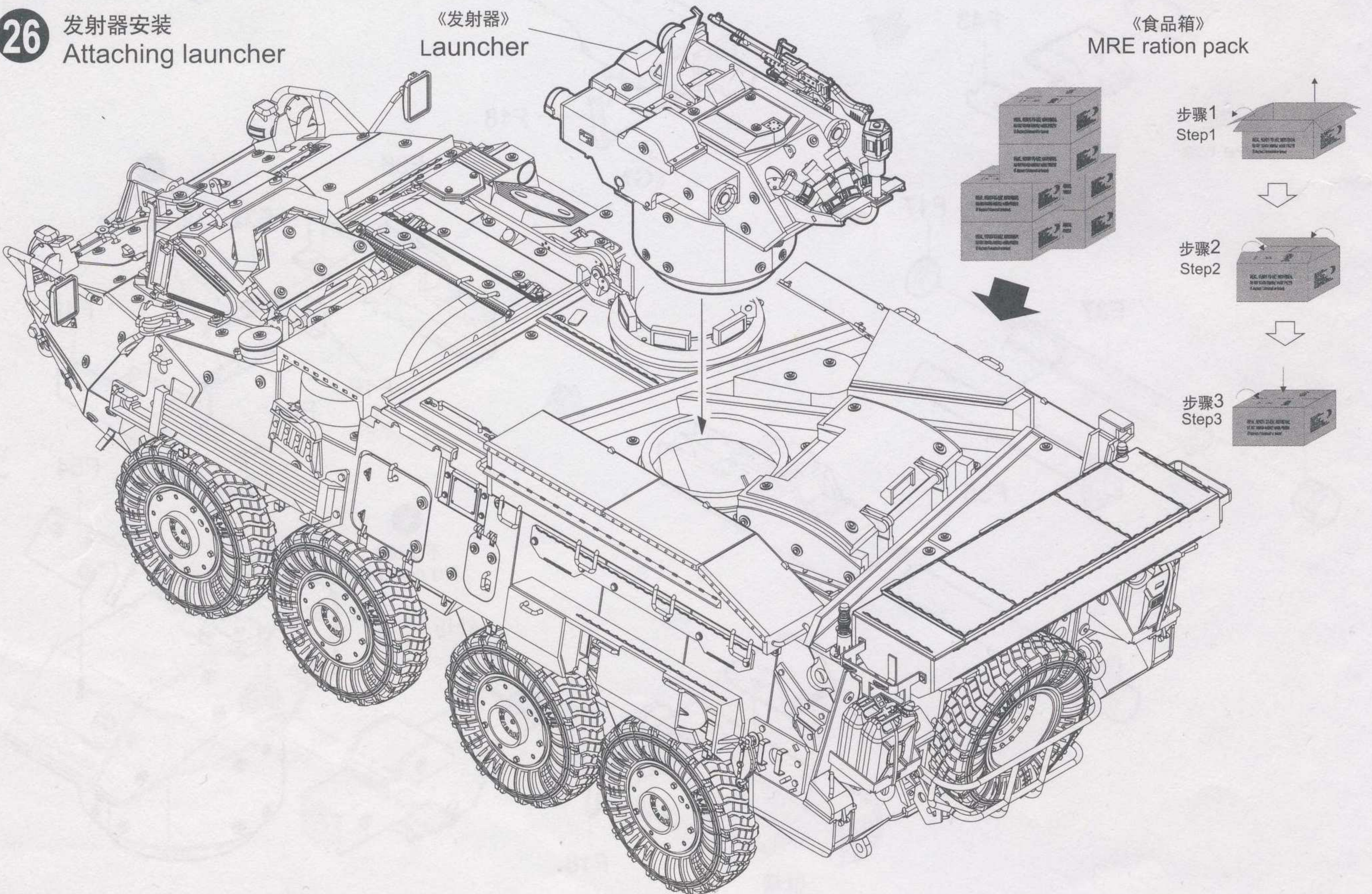

涂装同标贴指示

Painting & Marking guide

Color	Mr.Hobby	Vallejo	Model Master	Tamiya	Humbrol
Silver 银色	H 8 8	997	1546	X11	11
Metal Black 黑铁色	H 18 28	864	1402	-	-
Wood Brown 木棕色	H 37 43	983	1701	-	186
Red 红色	H 3 3	908	1503	X7	19
Light Green 橄榄绿色	H 303 303	-	1713	XF20	117
Tire Black 胎黑色	H 77 137	-	-	-	-
Flat black 消光黑	H 12 33	950	1749	XF1	33

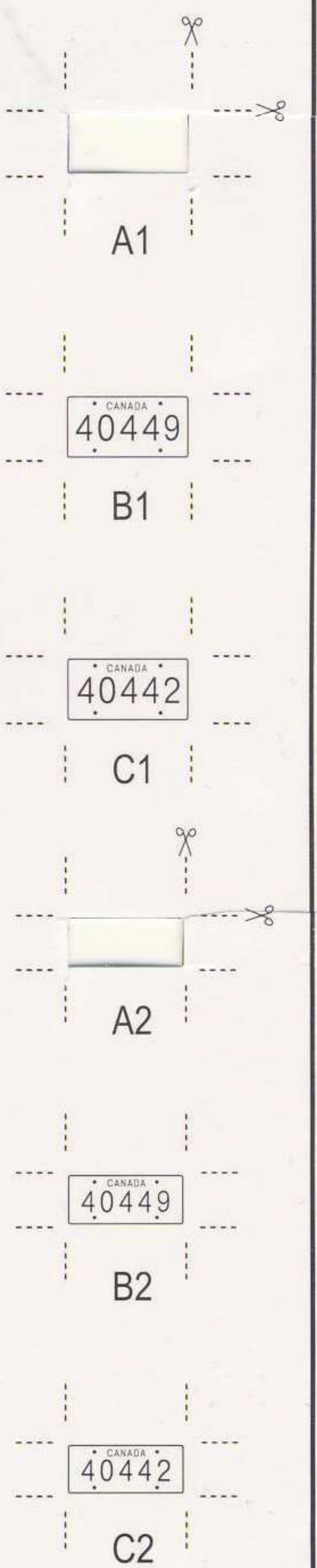
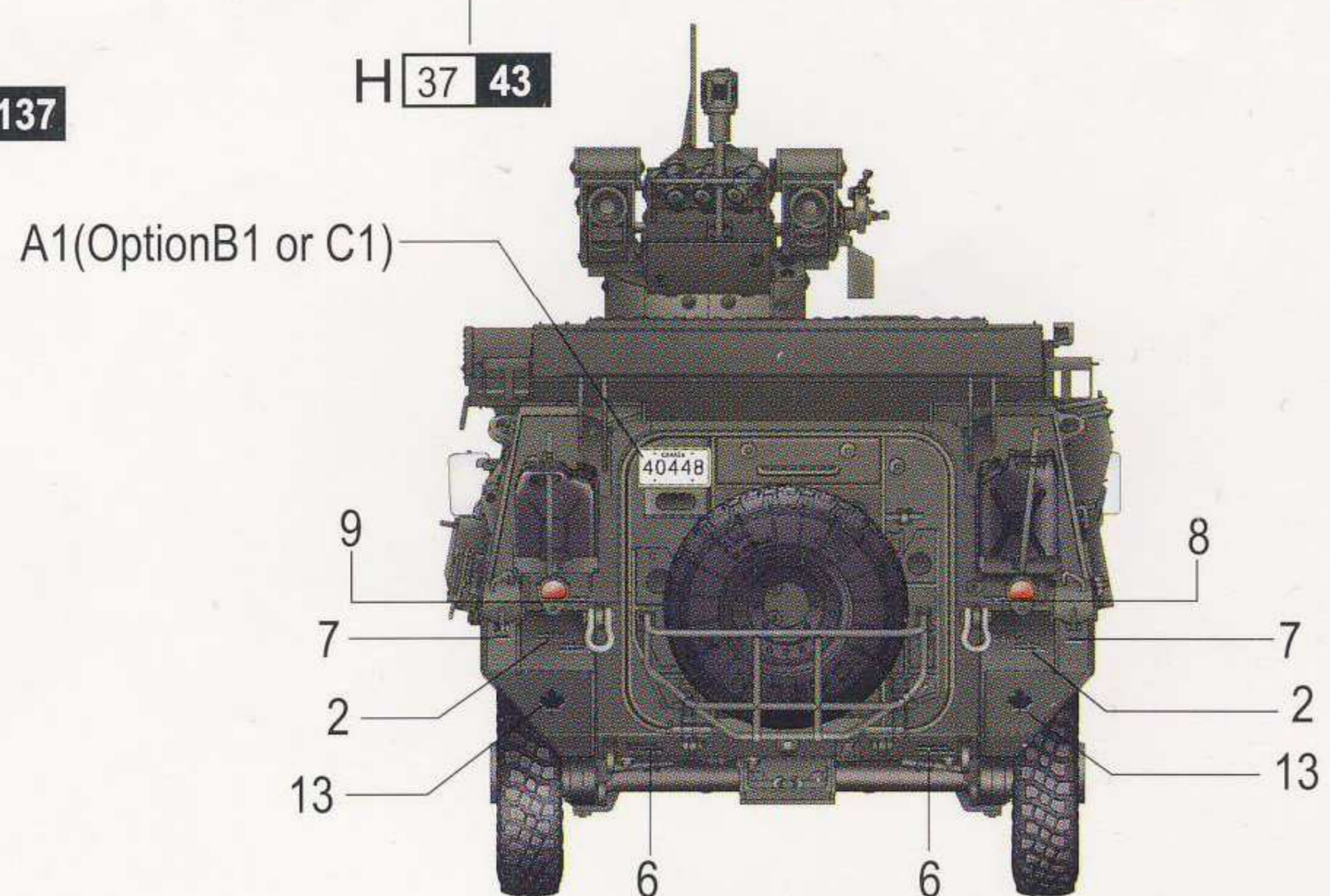
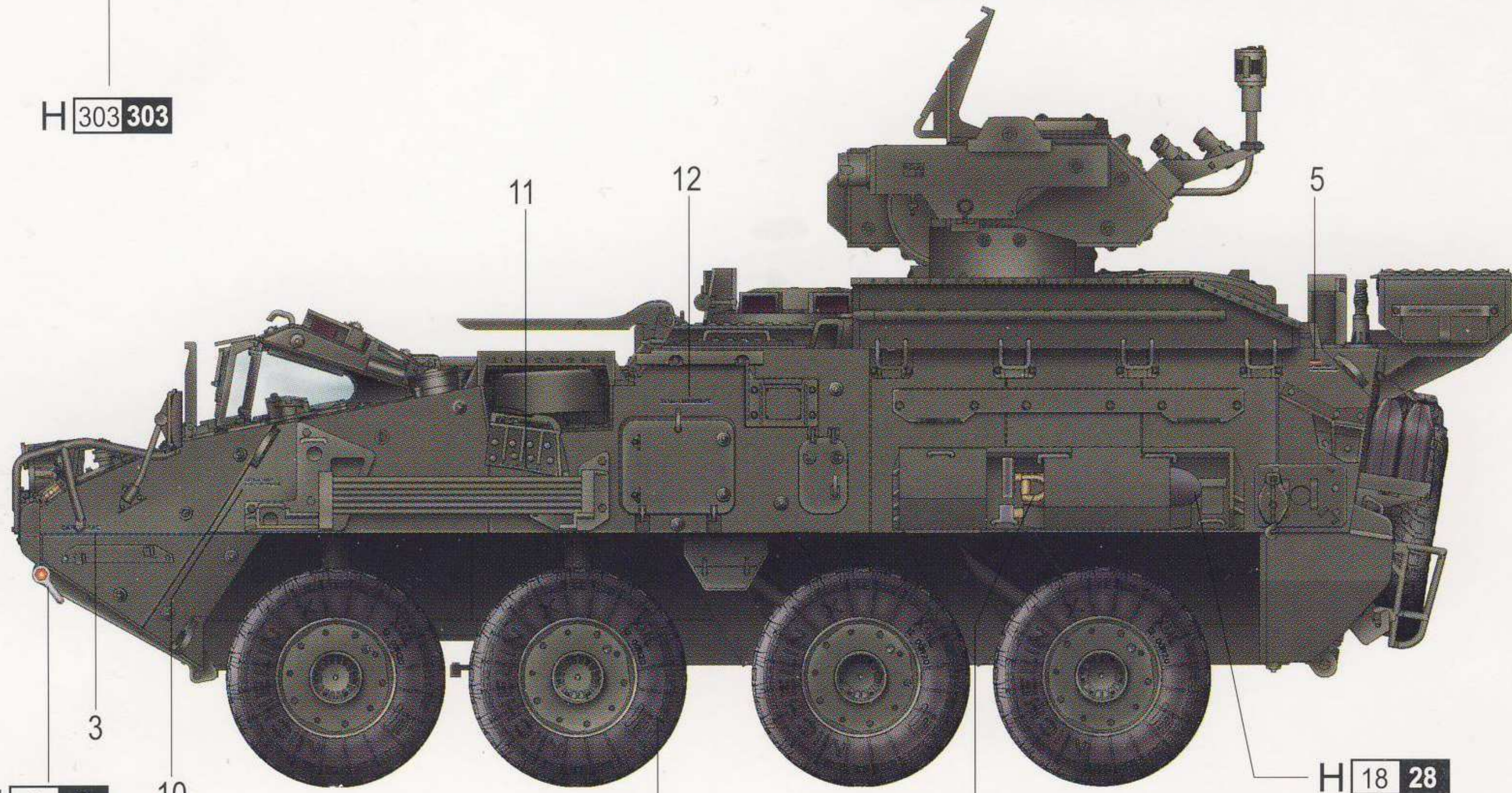
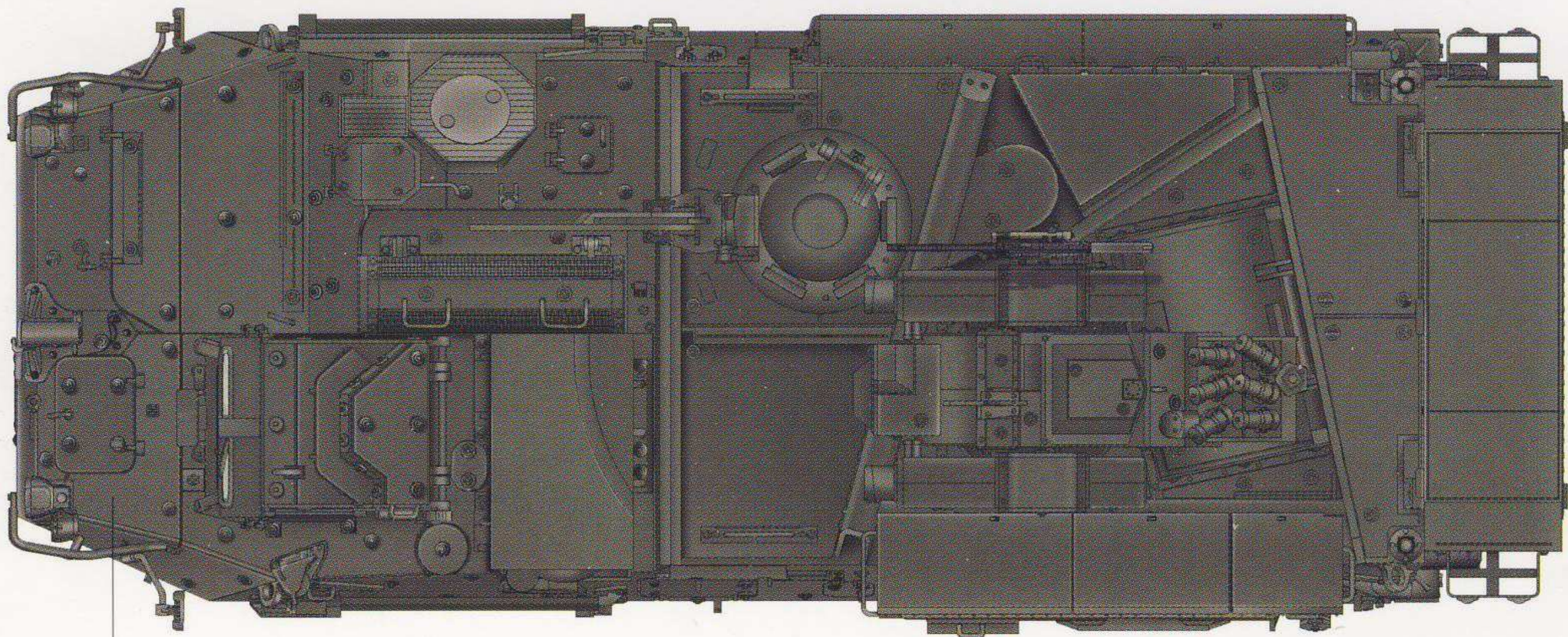
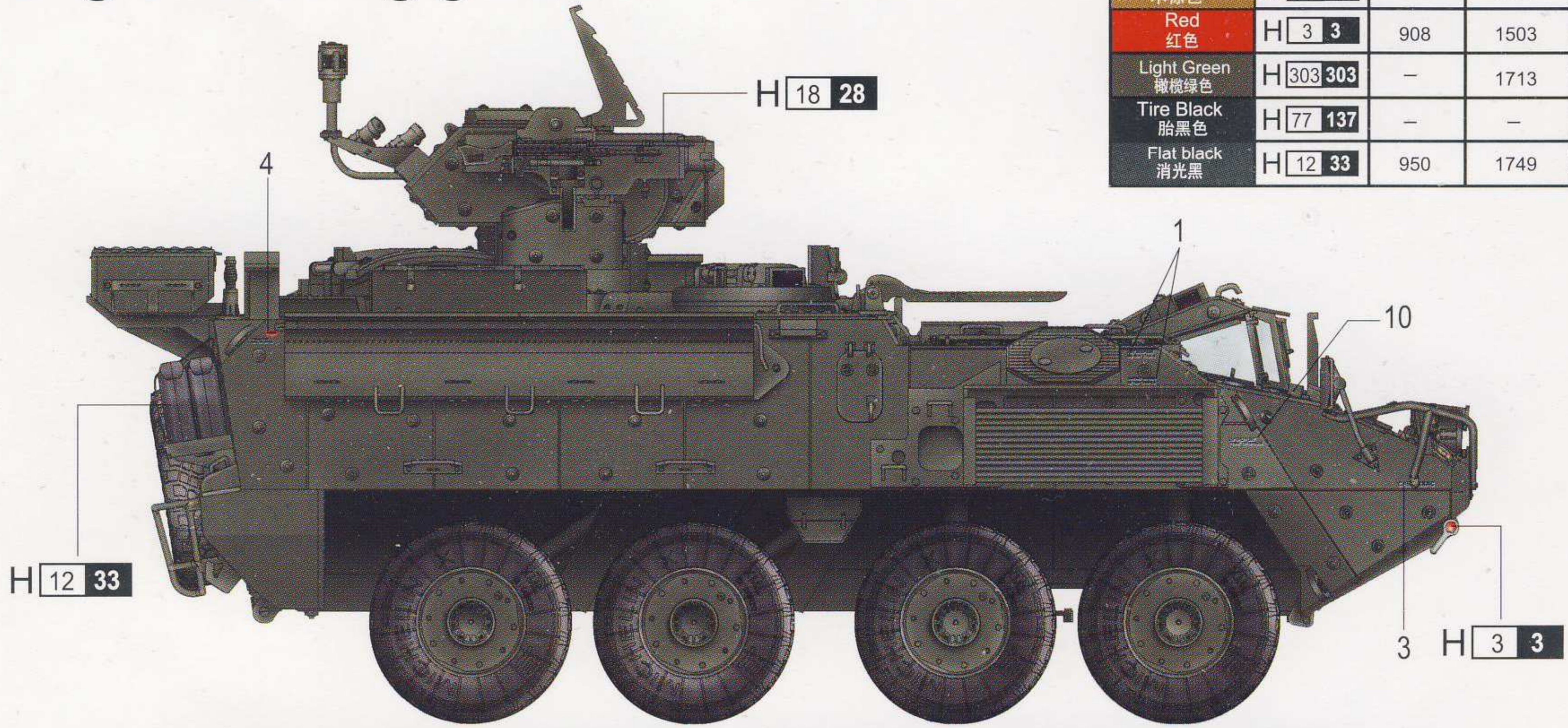

H AQUEOUS HOBBY COLOR

Mr. COLOR