

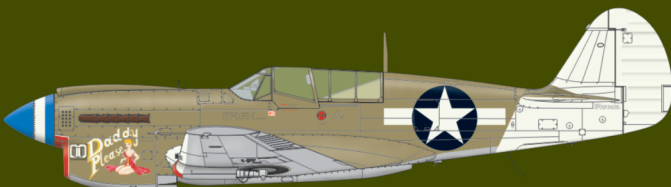

INSTRUCTION SHEET

WARHAWK P-40N

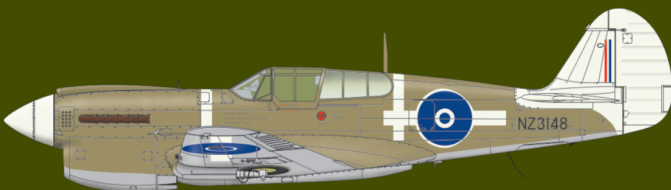

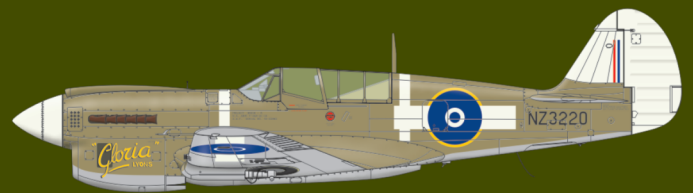

Carefully read instruction sheet before assembling. When you use glue or paint, do not use near open flame and use in well ventilated room. Keep out of reach of small children. Children must not be allowed to suck any part, or pull vinyl bag over the head.



Před započítím stavby si pečlivě prostudujte stavební návod. Při používání barev a lepidel pracujte v dobře větrané místnosti. Lepidla ani barvy nepoužívejte v blízkosti otevřeného ohně. Model není určen malým dětem, mohlo by dojít k požití drobných dílů.

INSTRUCTION SIGNS * INSTR. SYMBOLS * INSTRUKTION SINNBILDEN * SYMBOLES * 記号の説明



OPTIONAL
VOLBA



BEND
OHNOU



OPEN HOLE
VYVRTAT OTVOR



SYMMETRICAL ASSEMBLY
SYMETRICKÁ MONTÁŽ



REMOVE
ODŘÍZNOUT



REVERSE SIDE
OTOČIT



APPLY EDUARD MASK
AND PAINT
POUŽÍT EDUARD MASK
NABARVIT

PARTS



DÍLY



TEILE



PIĘCES



部品

A>

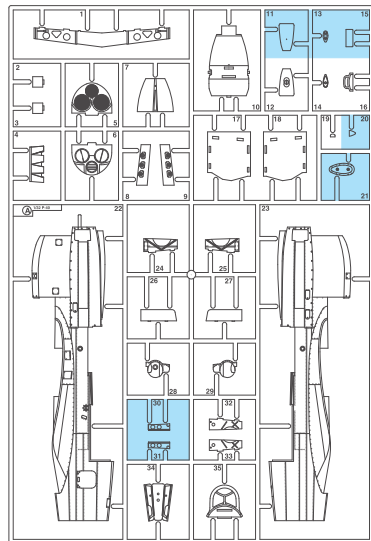

B>

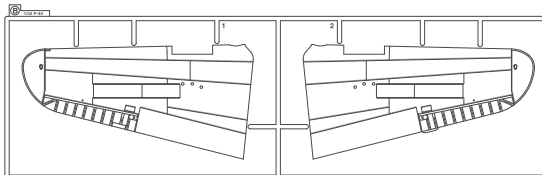

I>

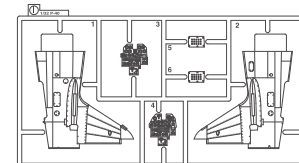

PLASTIC PARTS

C>

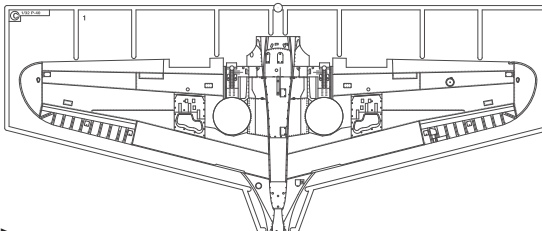

K>

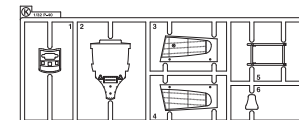

E>

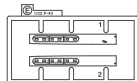

P>



Q> 2 pcs.

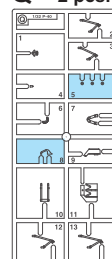

R> 2 pcs.

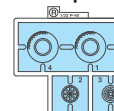

V>

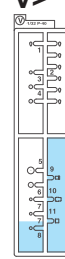

J>

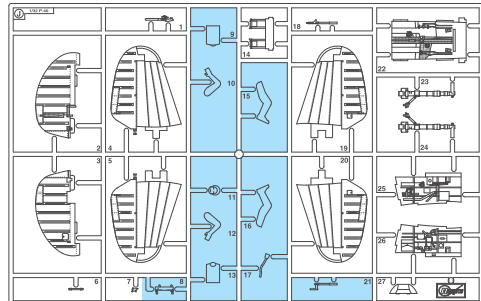

O>

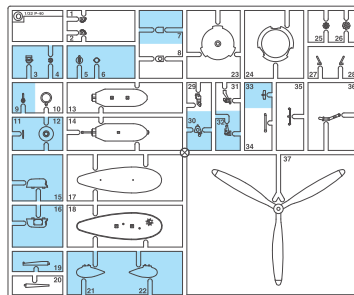

L>

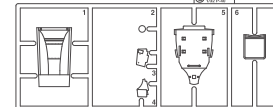

S> 2 pcs.

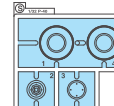

U> 2 pcs.

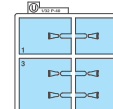

X>

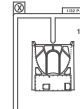

Y>

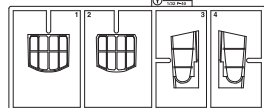

RP - RESIN PARTS



R13



R15



R17

R18
2 pcs.

R19

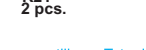

R20

R21
2 pcs.

R5

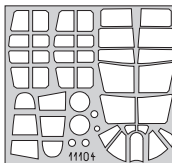
eduard
MASK

FILM



PE - PHOTO ETCHED DETAIL PARTS

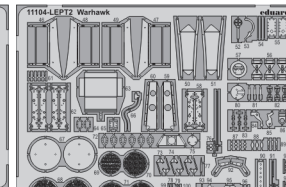
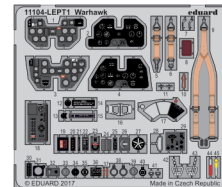

-Parts not for use. -Teile werden nicht verwendet. -Pièces à ne pas utiliser. -Tyto díly nepoužívejte při stavbě. - 使用しない部品

COLOURS



BARVY



FARBEN



PEINTURE



色

GSI Creos (GUNZE)		
AQUEOUS	Mr.COLOR	
H4	C4	YELLOW
H8	C8	SILVER
H11	C62	WHITE
H12	C33	FLAT BLACK
H25	C34	BLUE
H47	C41	RED BROWN
H52	C12	OLIVE DRAB
H53	C13	GRAY
H58	C351	ZINC CHROMATE
H84	C17	DARK GREEN

AQUEOUS	Mr.COLOR	
H77	C137	TIRE BLACK
H78	C38	OLIVE DRAB
H90	C47	CLEAR RED
H94	C138	CLEAR GREEN
H325	C325	GRAY
H327	C327	RED
H329	C329	YELLOW
H330	C330	DARK GREEN
Mr.METAL COLOR		
MC214		DARK IRON
MC218		ALUMINIUM

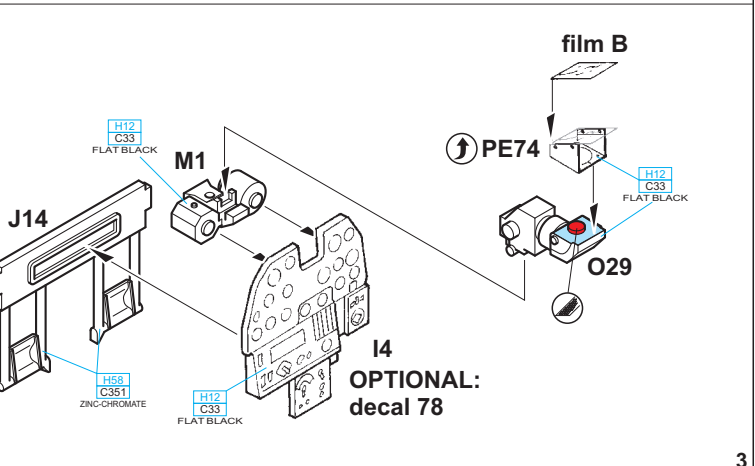
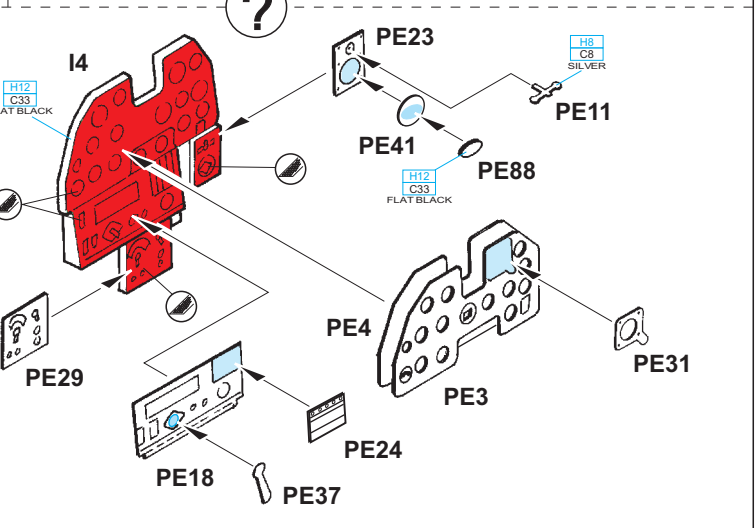
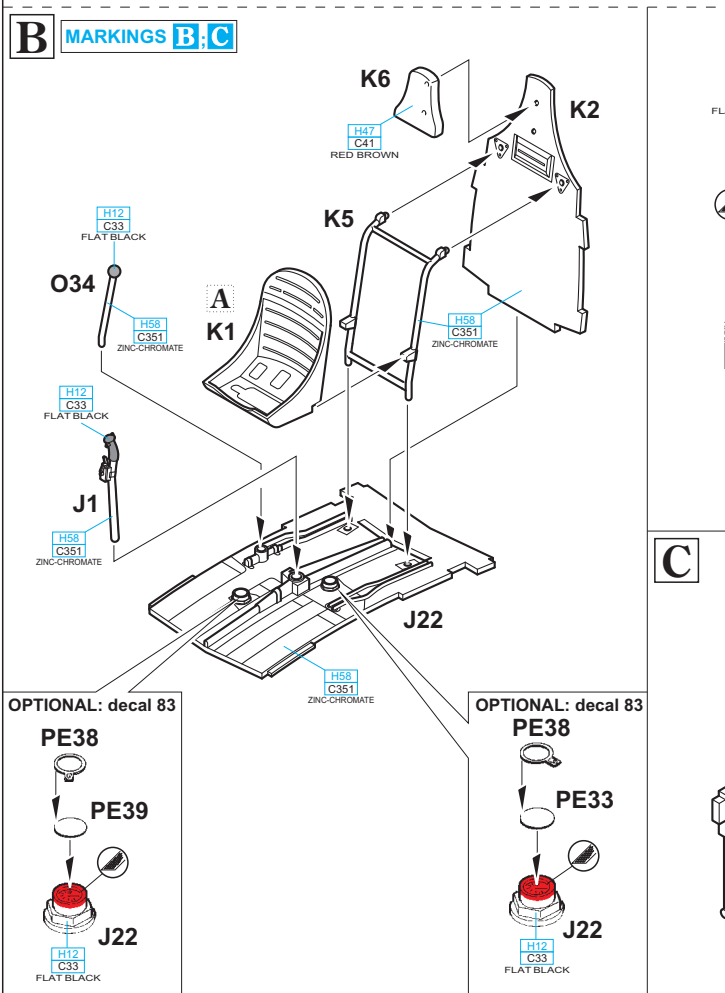
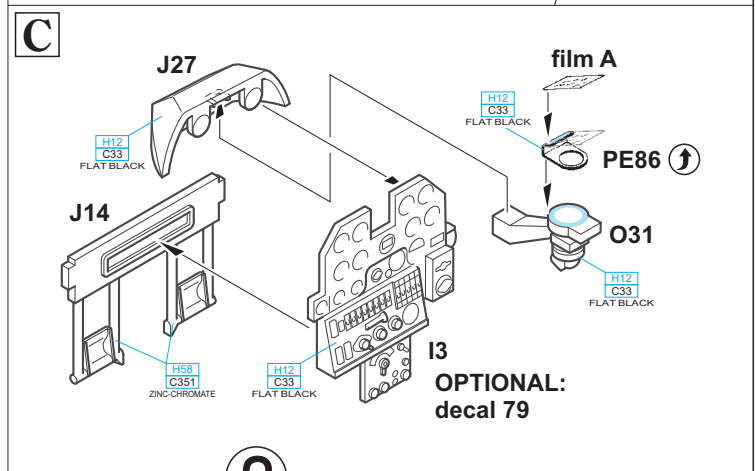
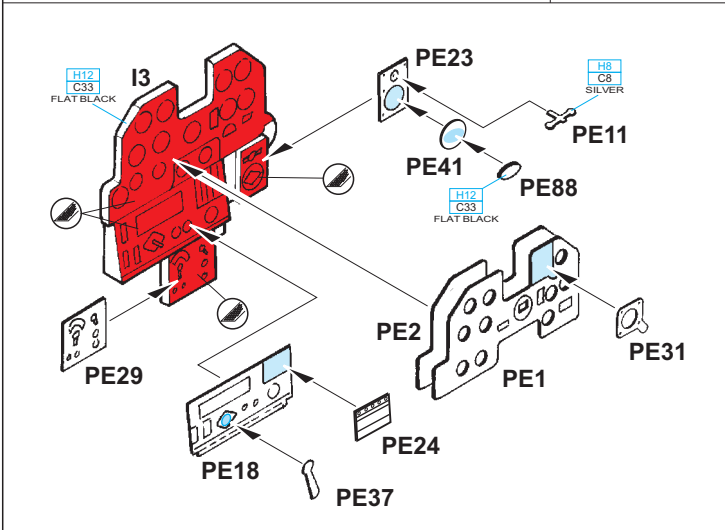
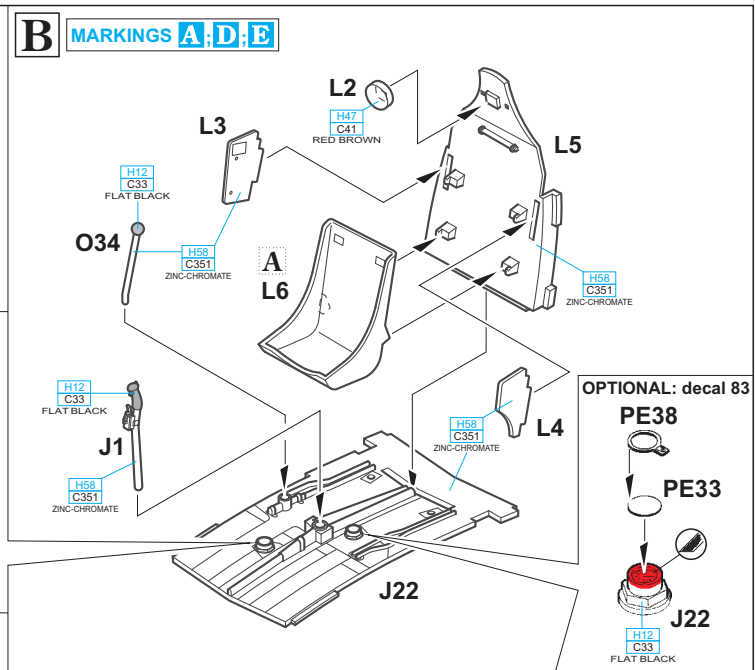
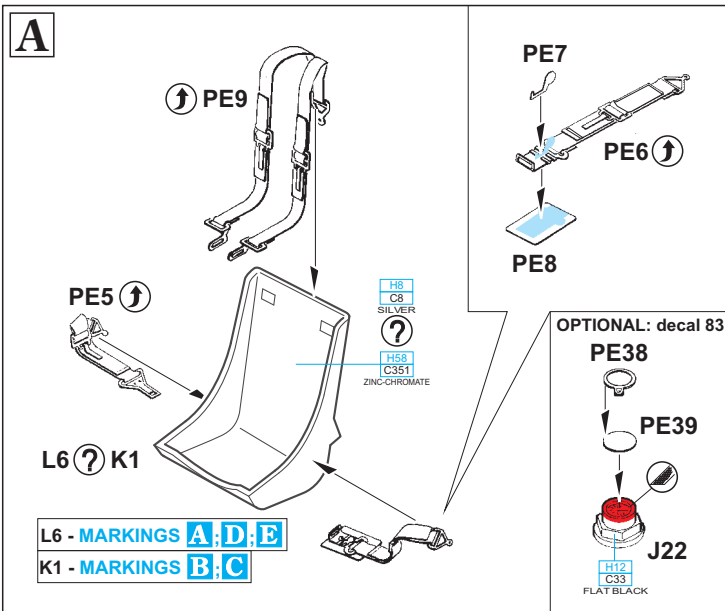

D

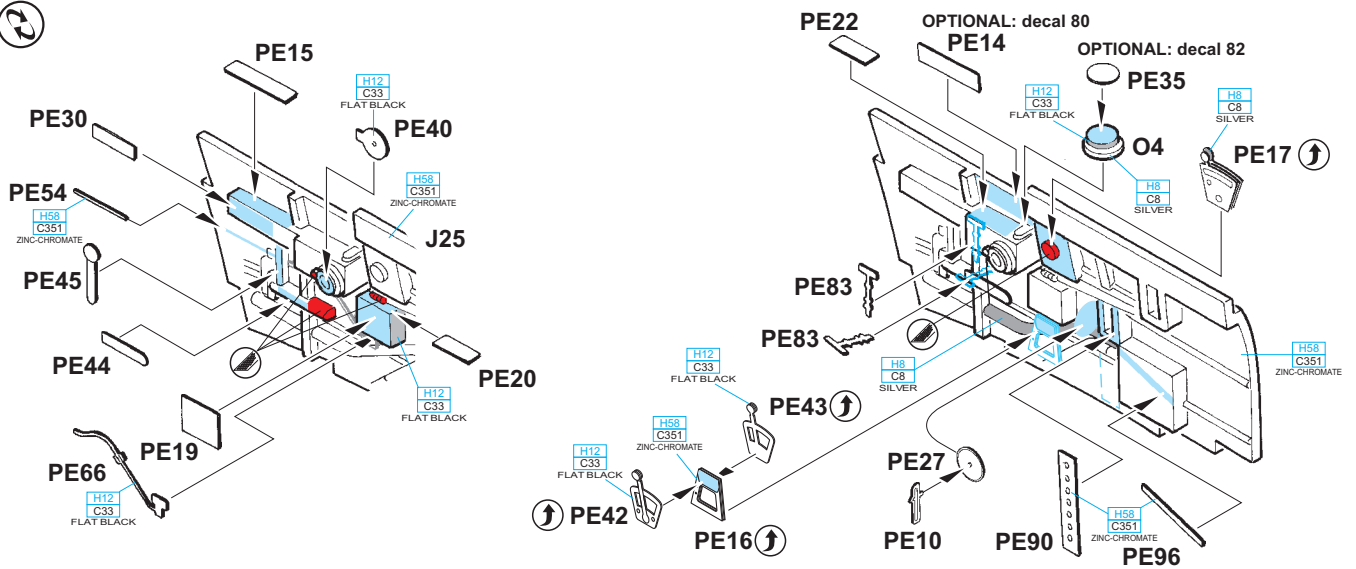

E

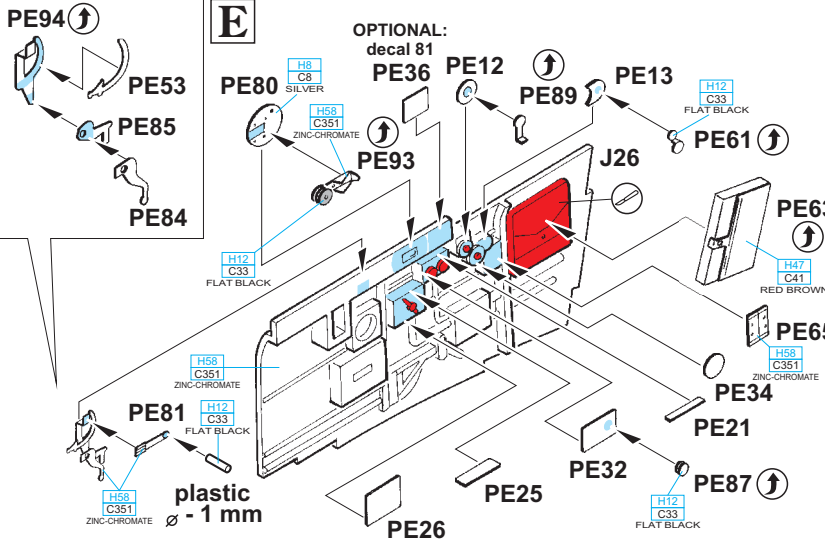

F

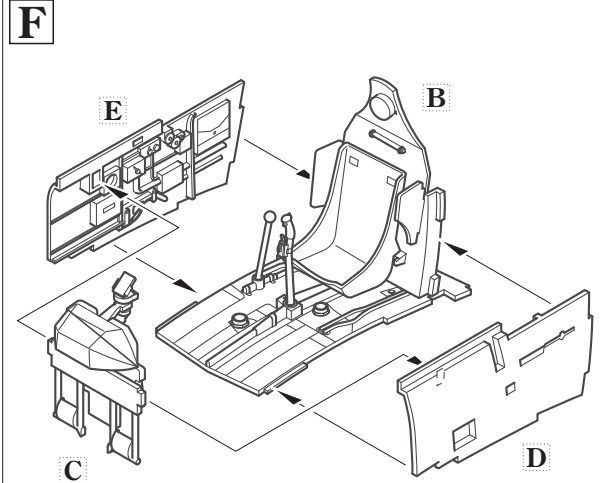

Z3

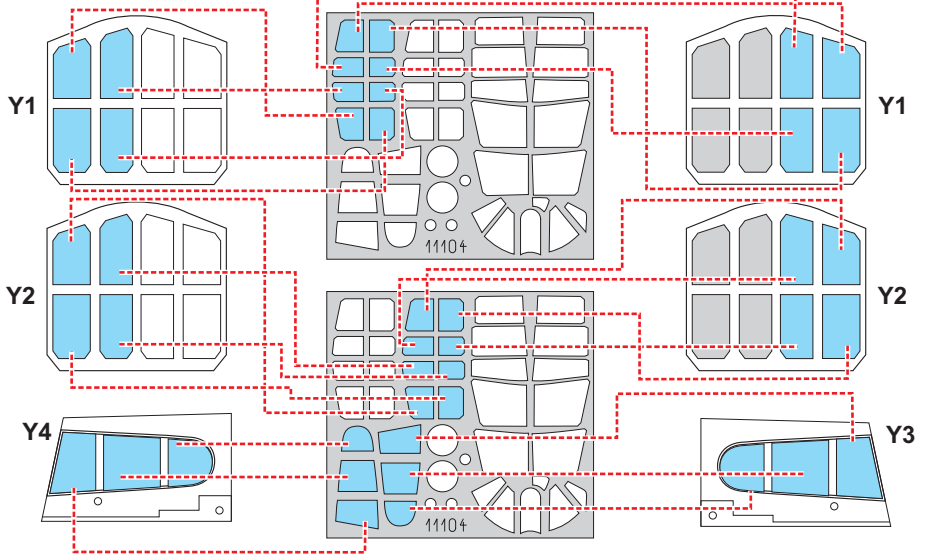
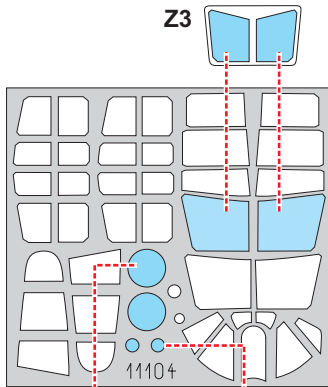

RP18
2 pcs.

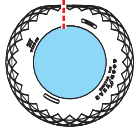

V5

V6

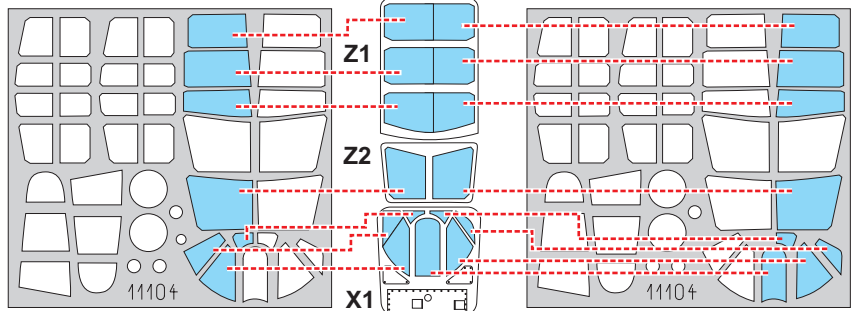
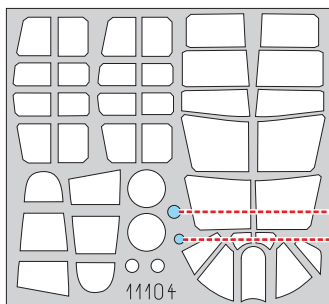

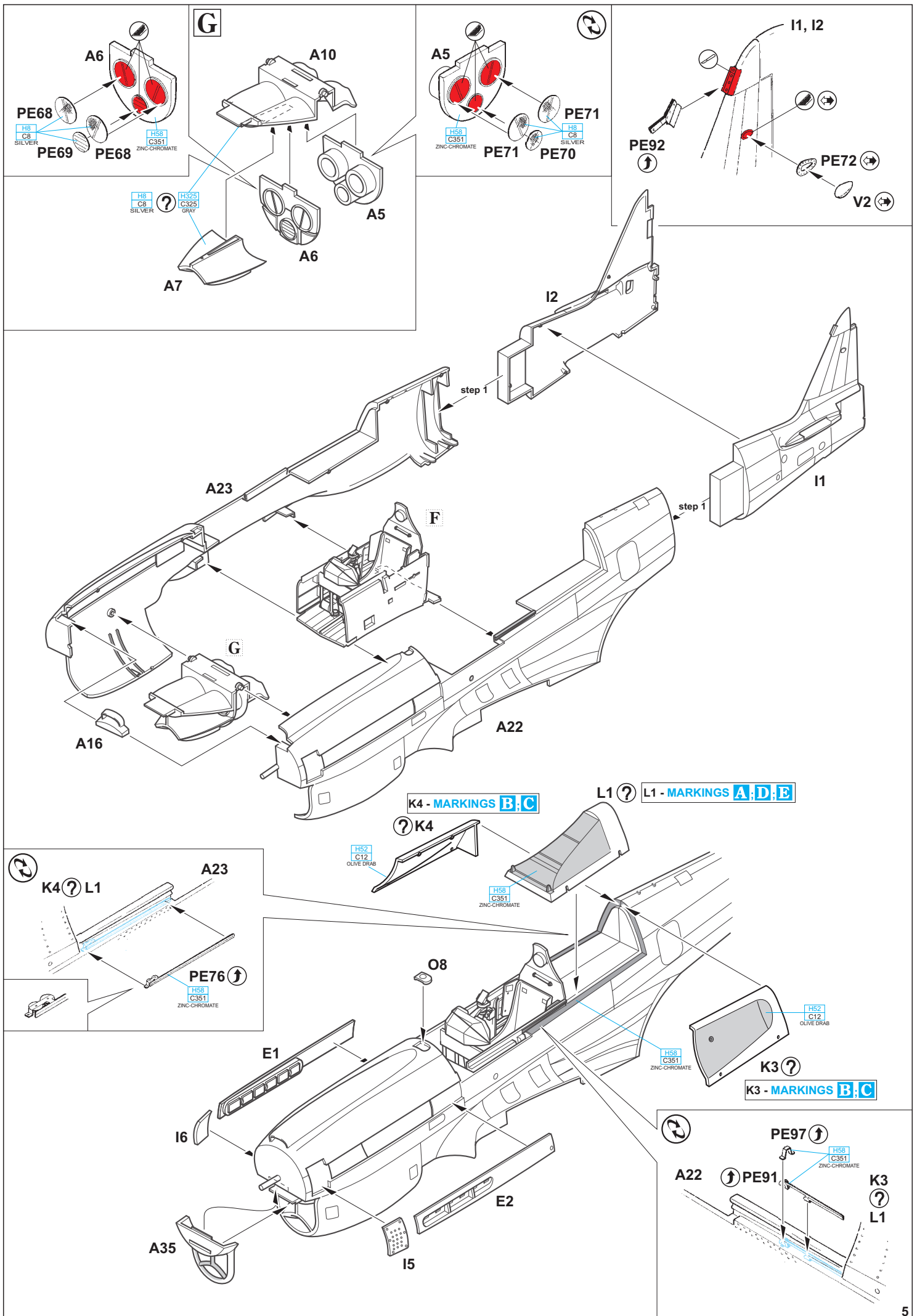

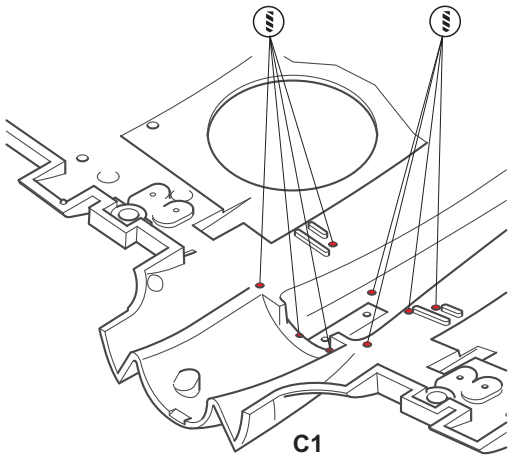

C1

H

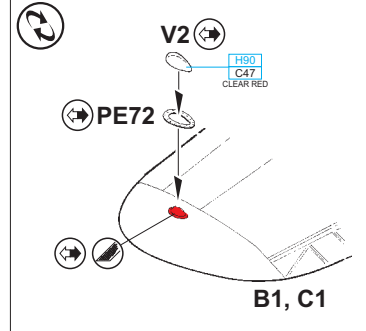
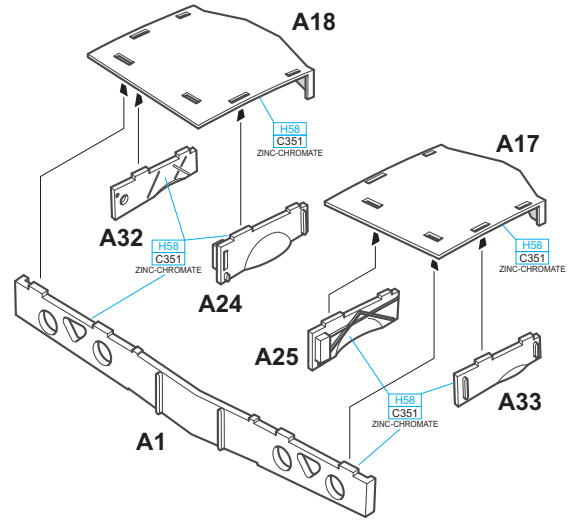

B1, C1

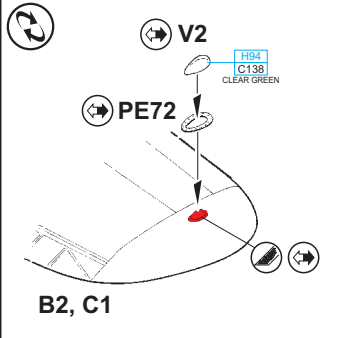

B2, C1

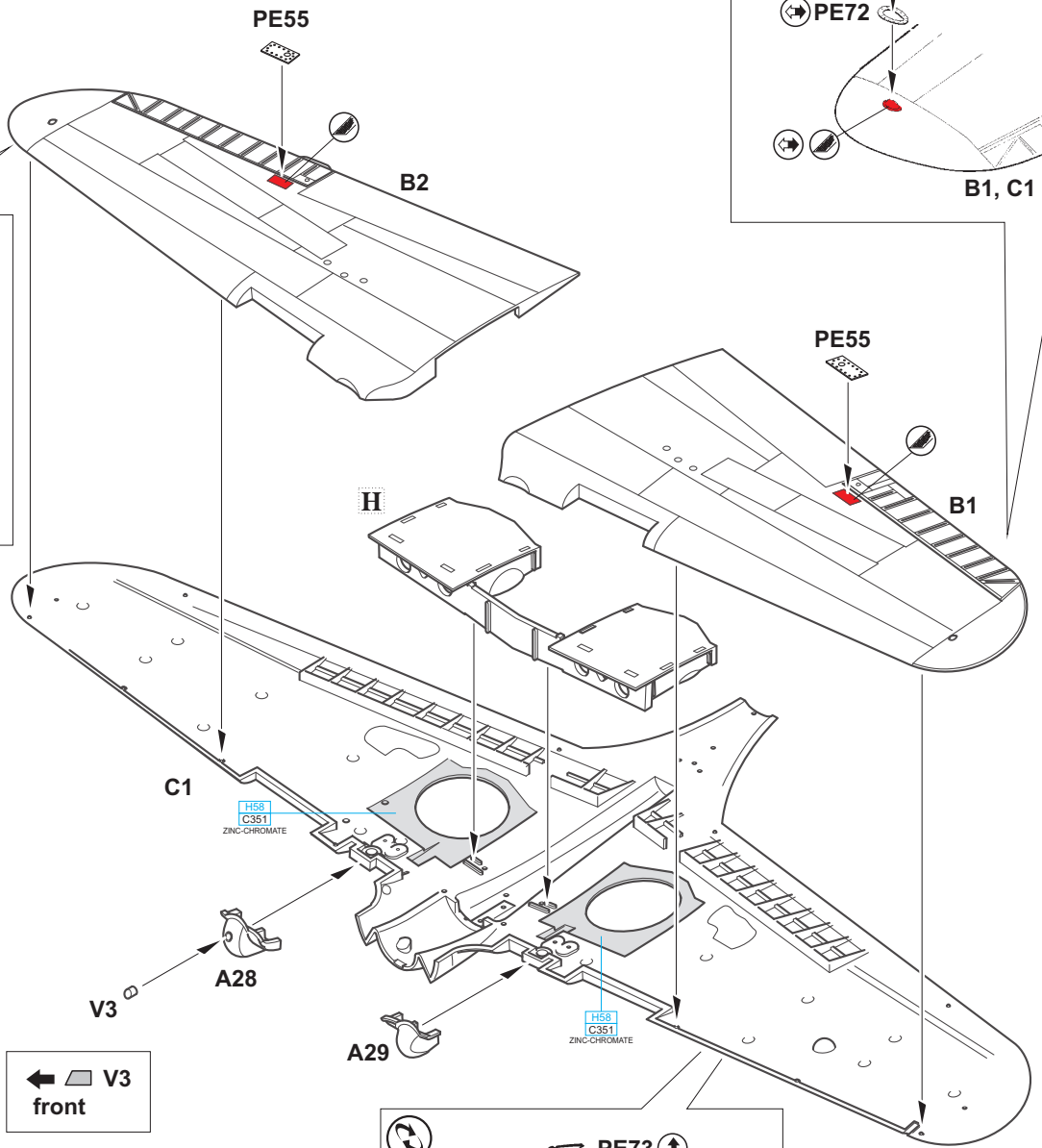

← V3 front

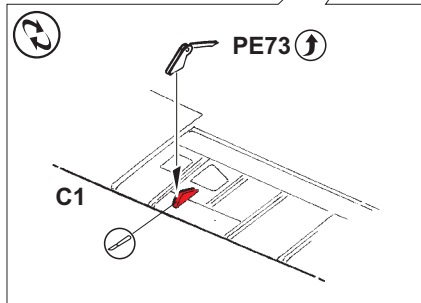

C1

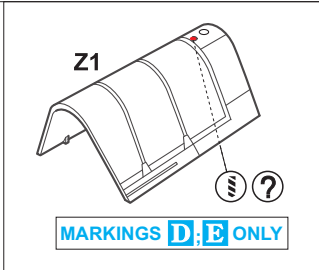
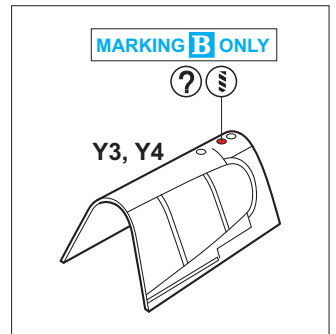
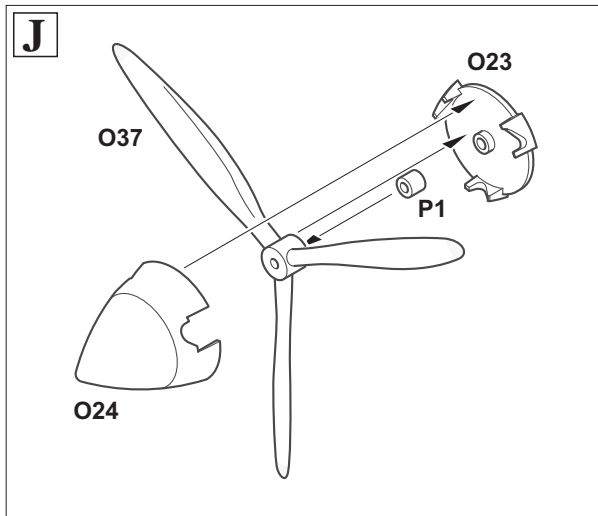
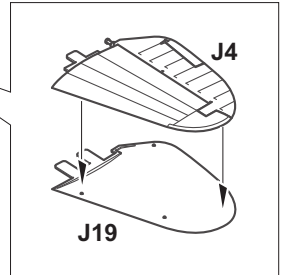
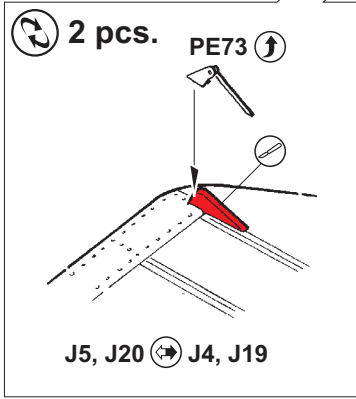
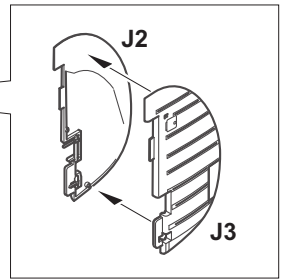
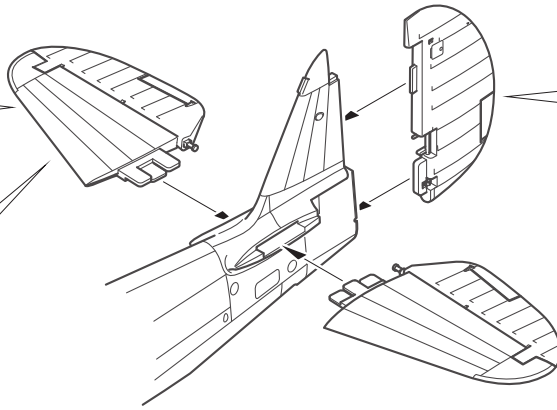
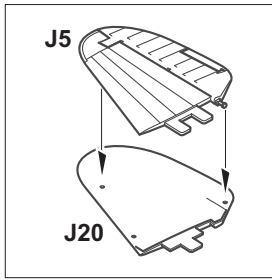

Z1 - MARKINGS A; D; E ONLY

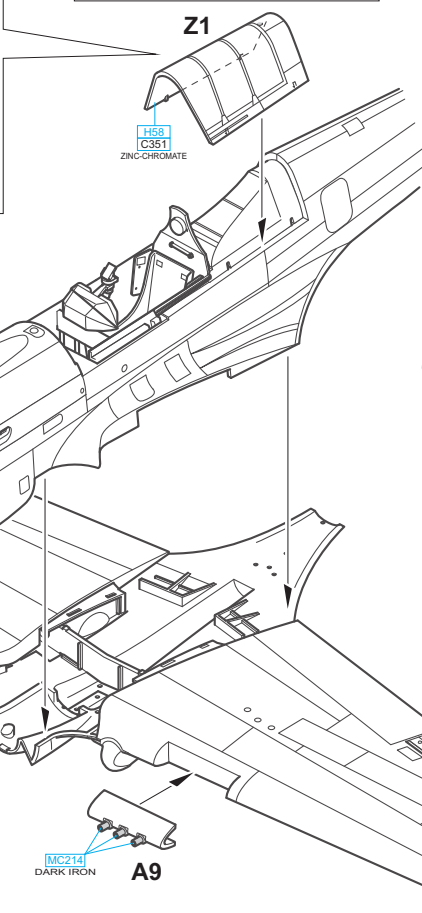

Y3, Y4 - MARKINGS B; C ONLY

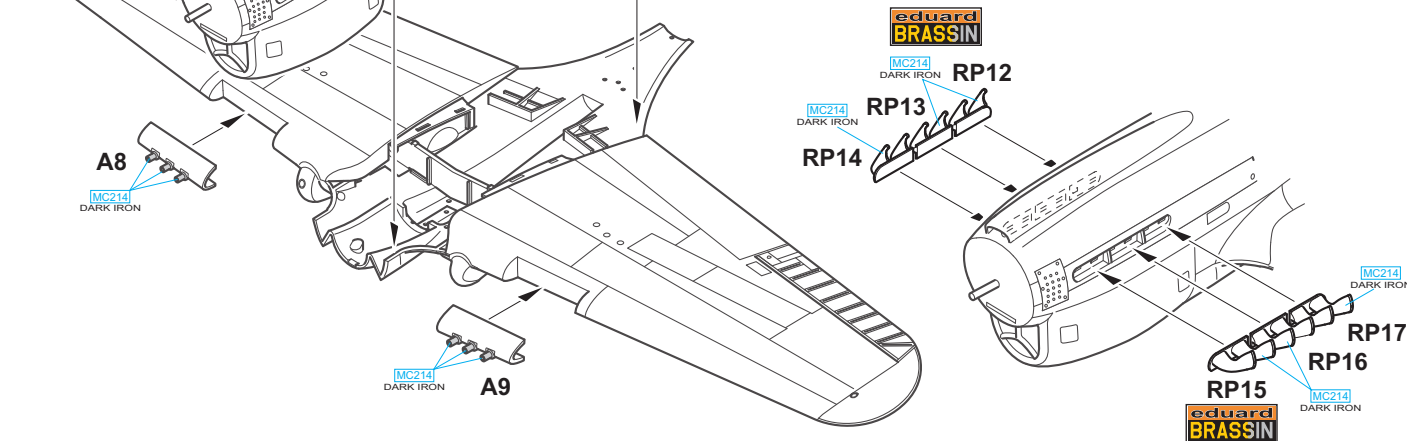
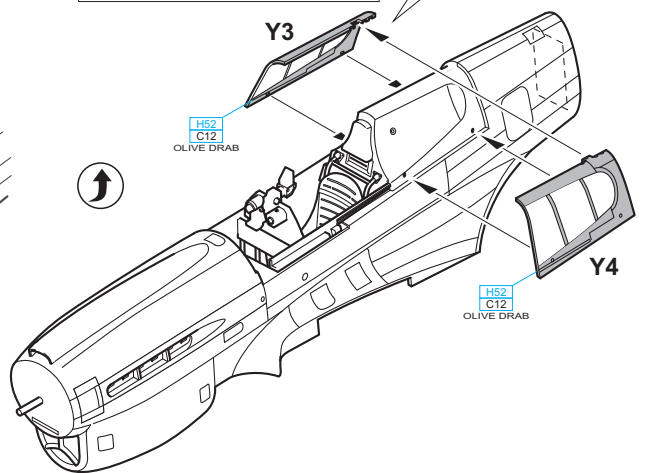

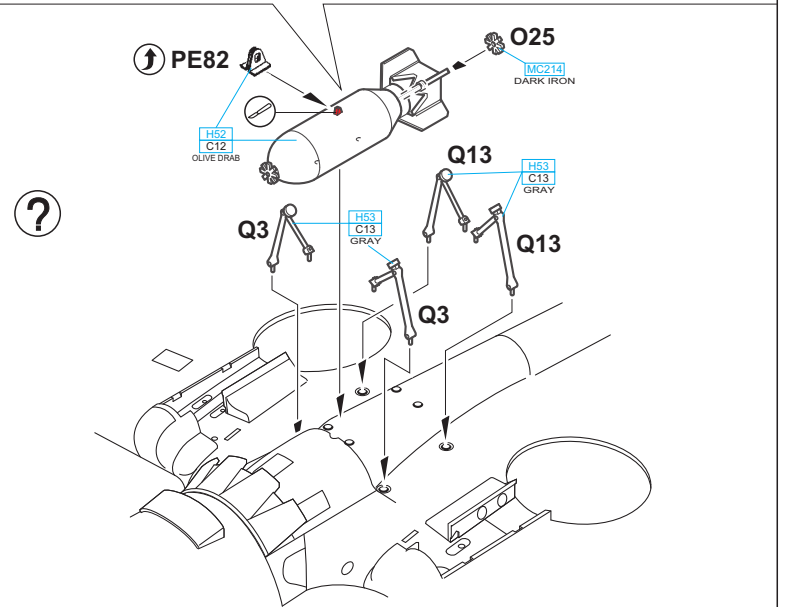
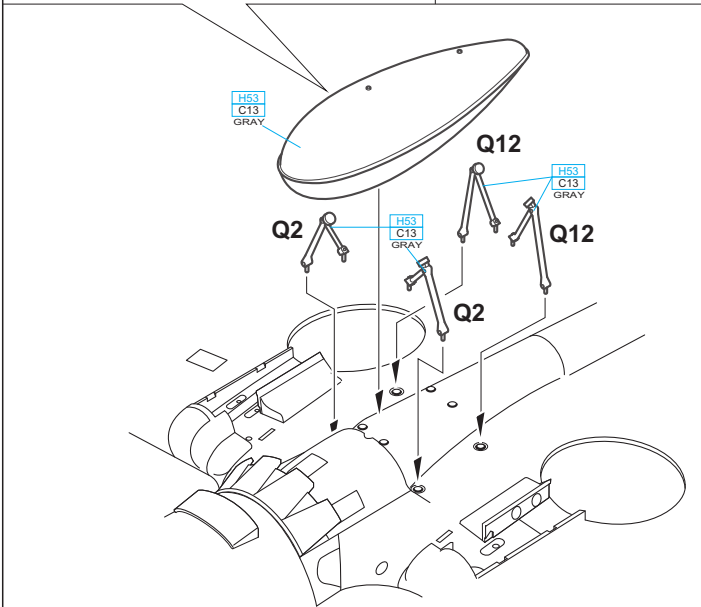
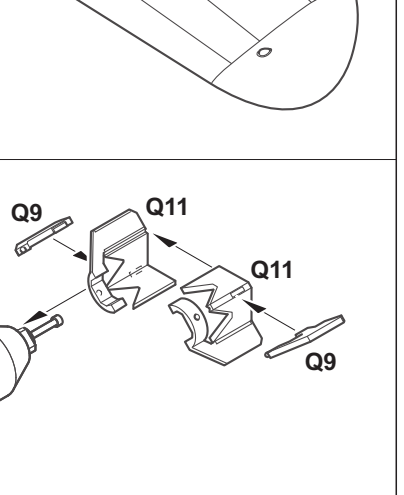
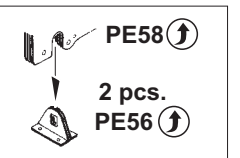
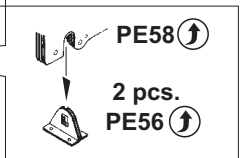
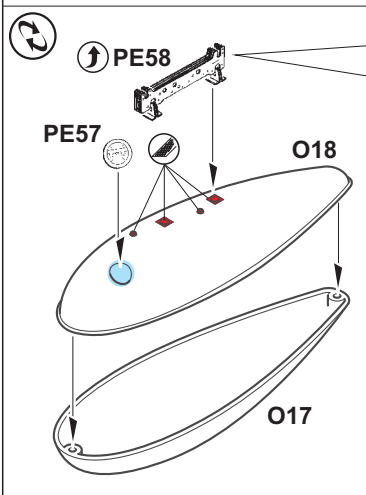
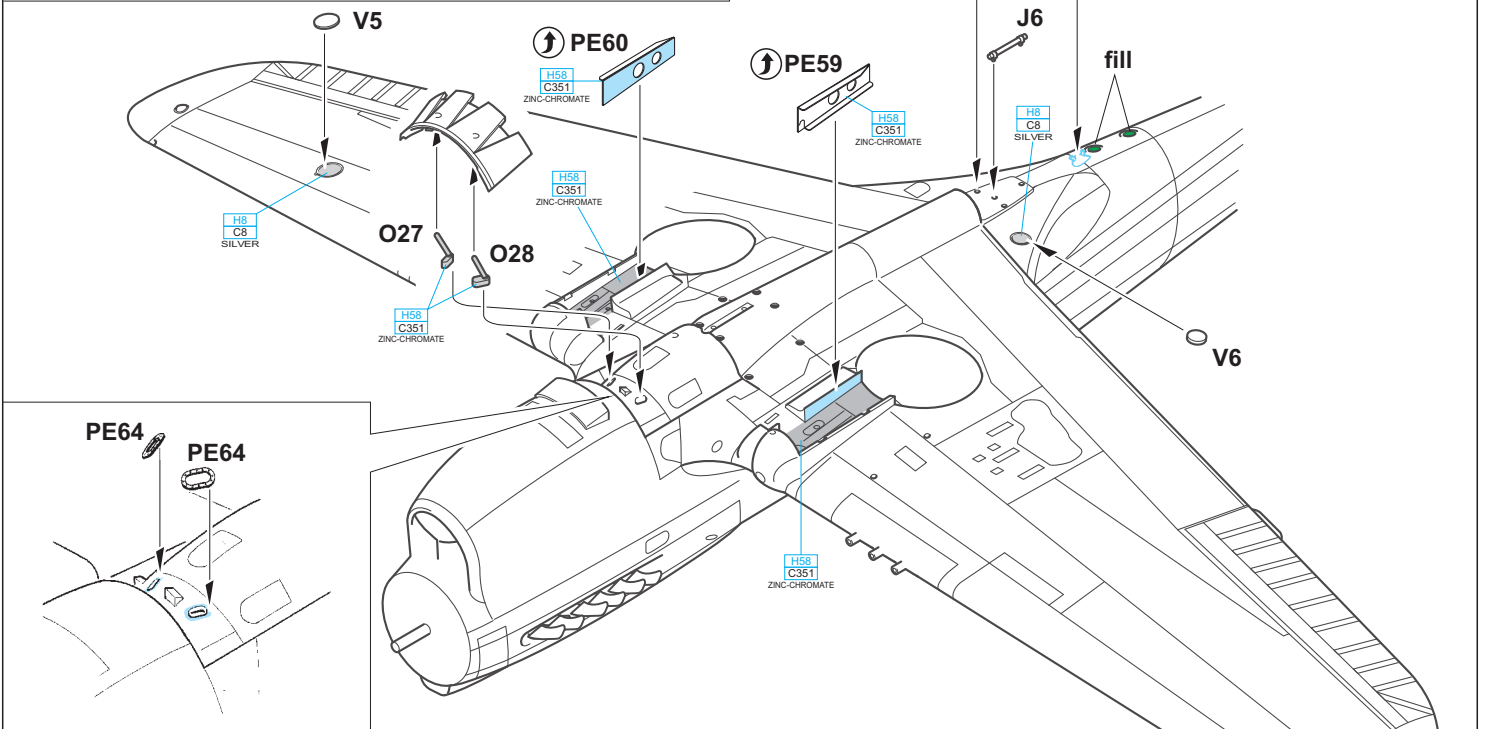
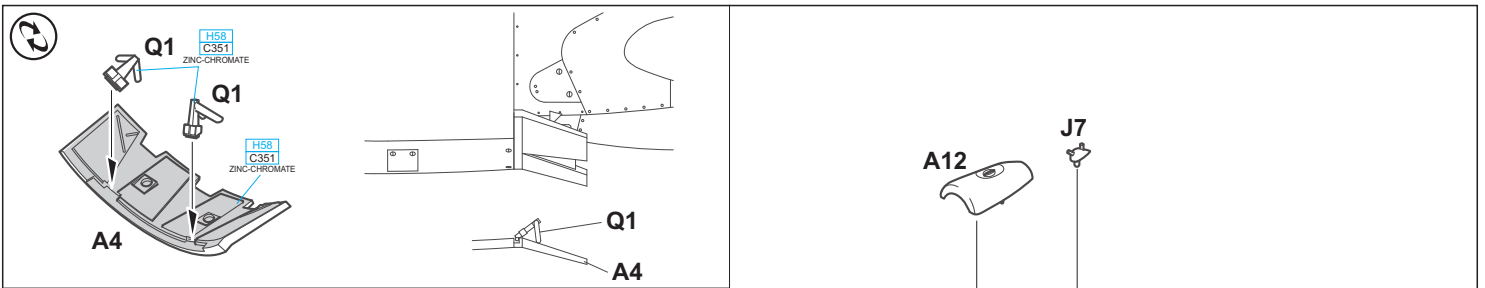

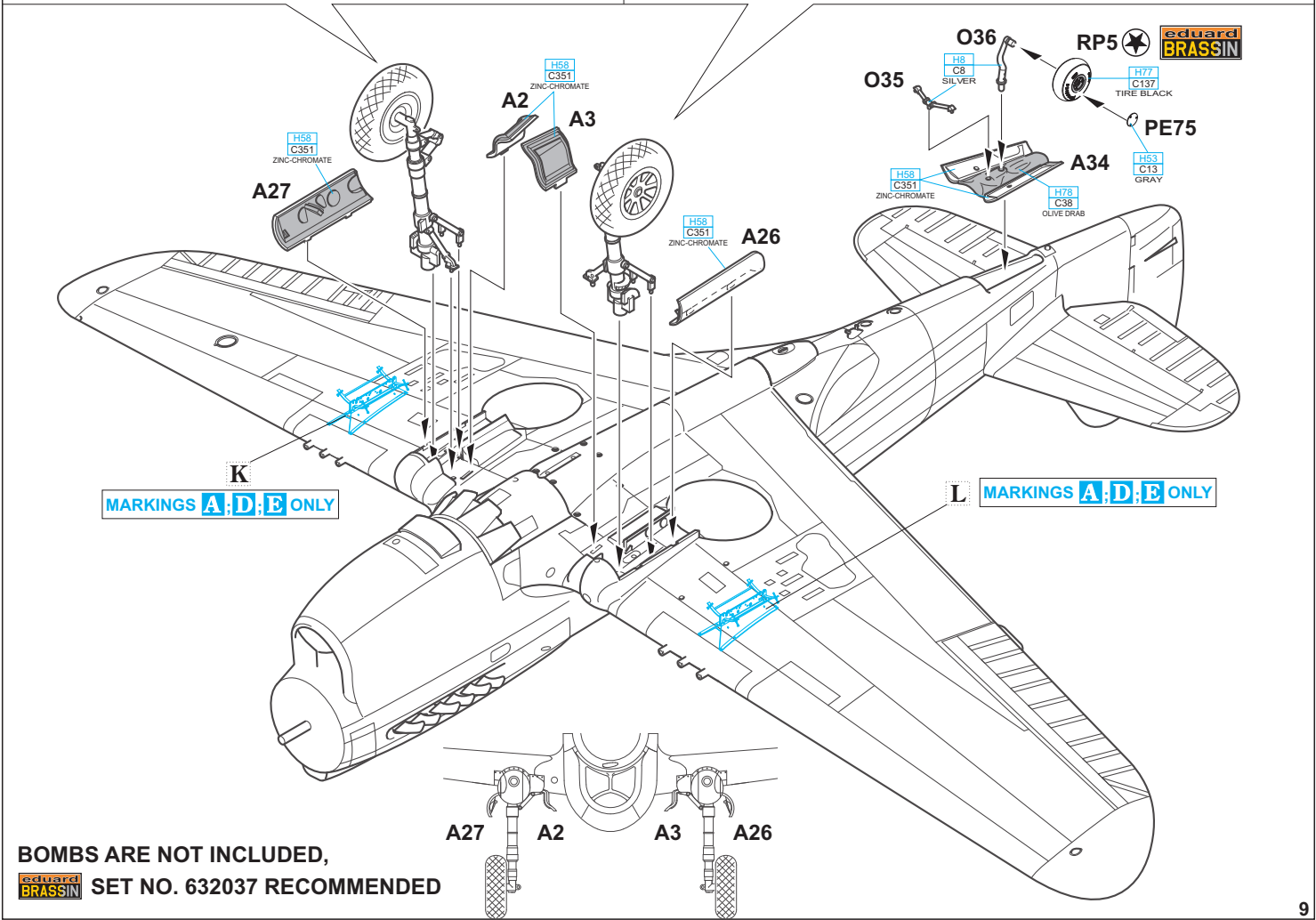
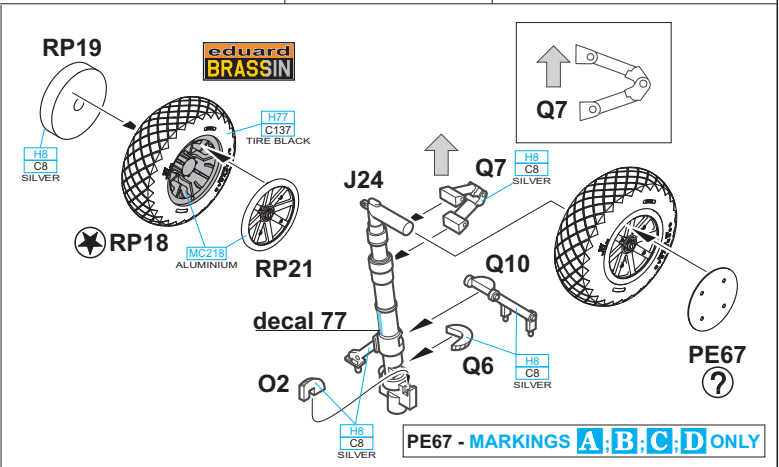
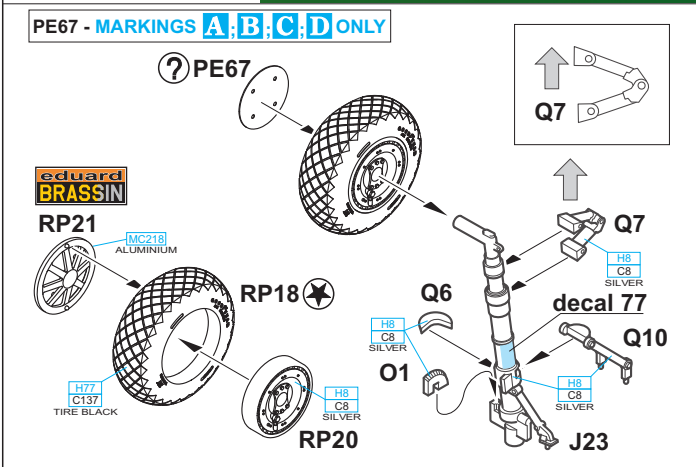
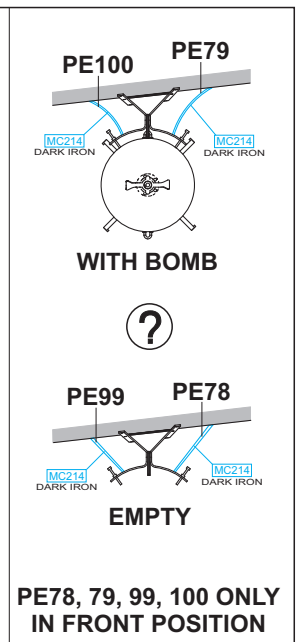
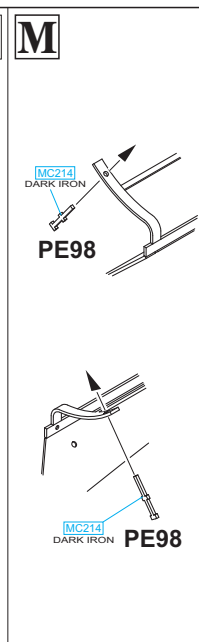
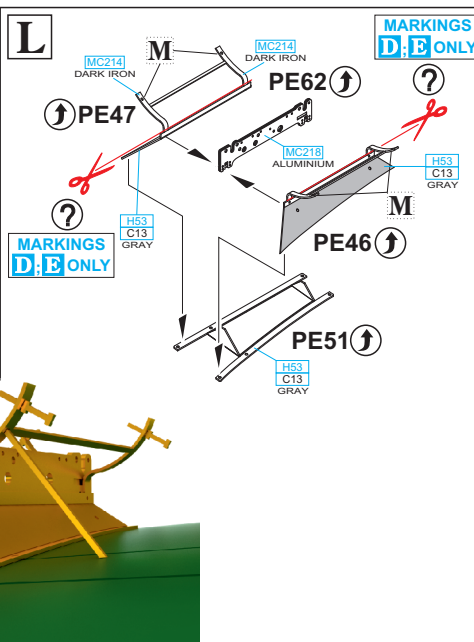
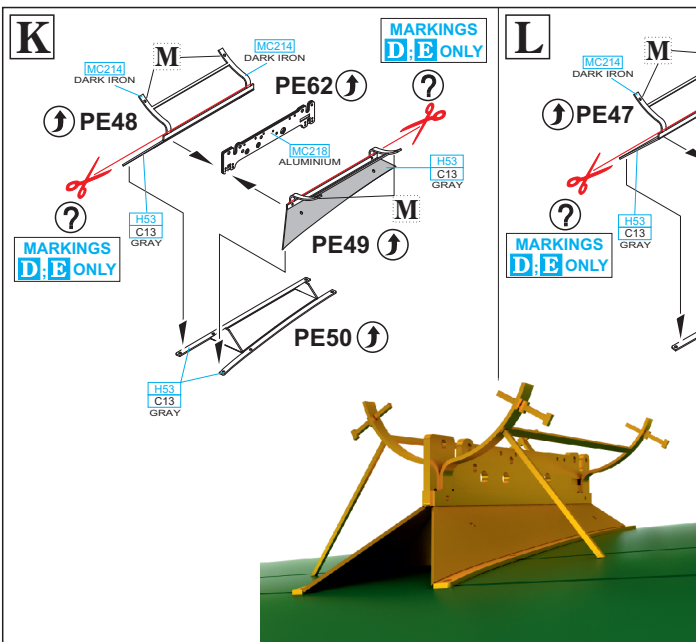

PE28 - MARKINGS
A; B; D; E ONLY

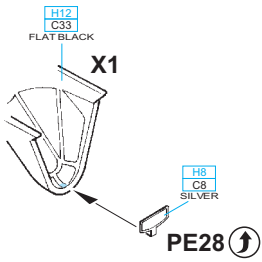

?

MARKINGS A; D; E ONLY

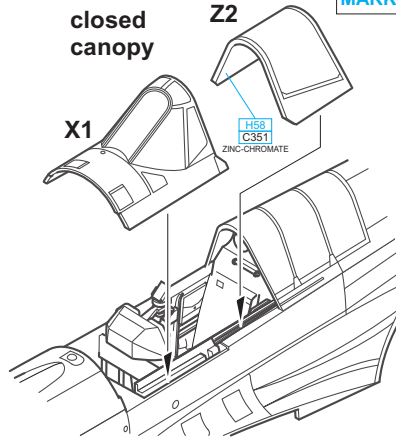

?

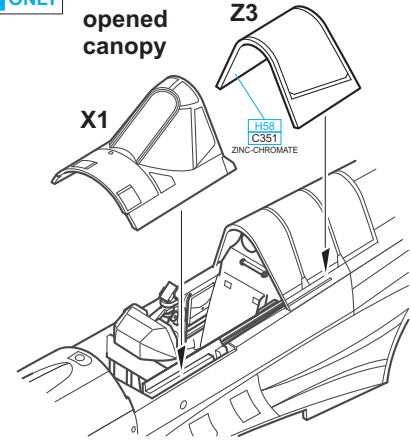

A19 - MARKING C ONLY

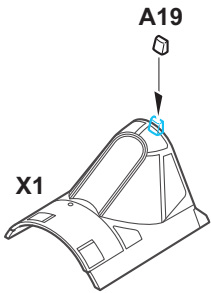

?

closed canopy Y2

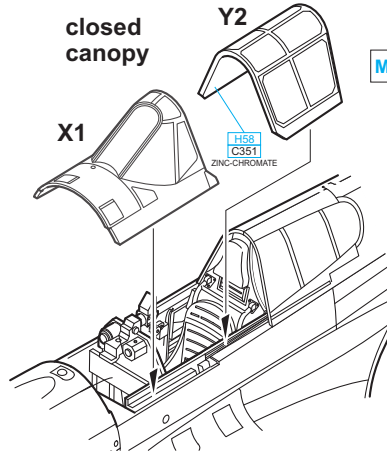

?

MARKINGS B; C ONLY

opened canopy Y1

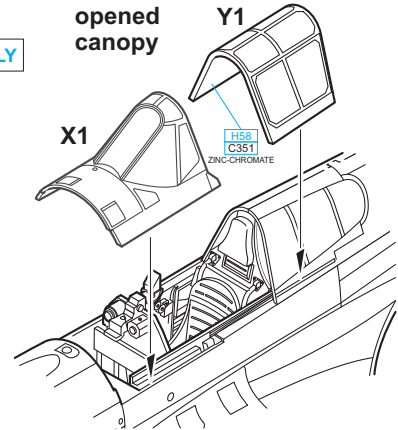

A14, O10 - MARKING C ONLY

O20 - MARKINGS B; D; E ONLY

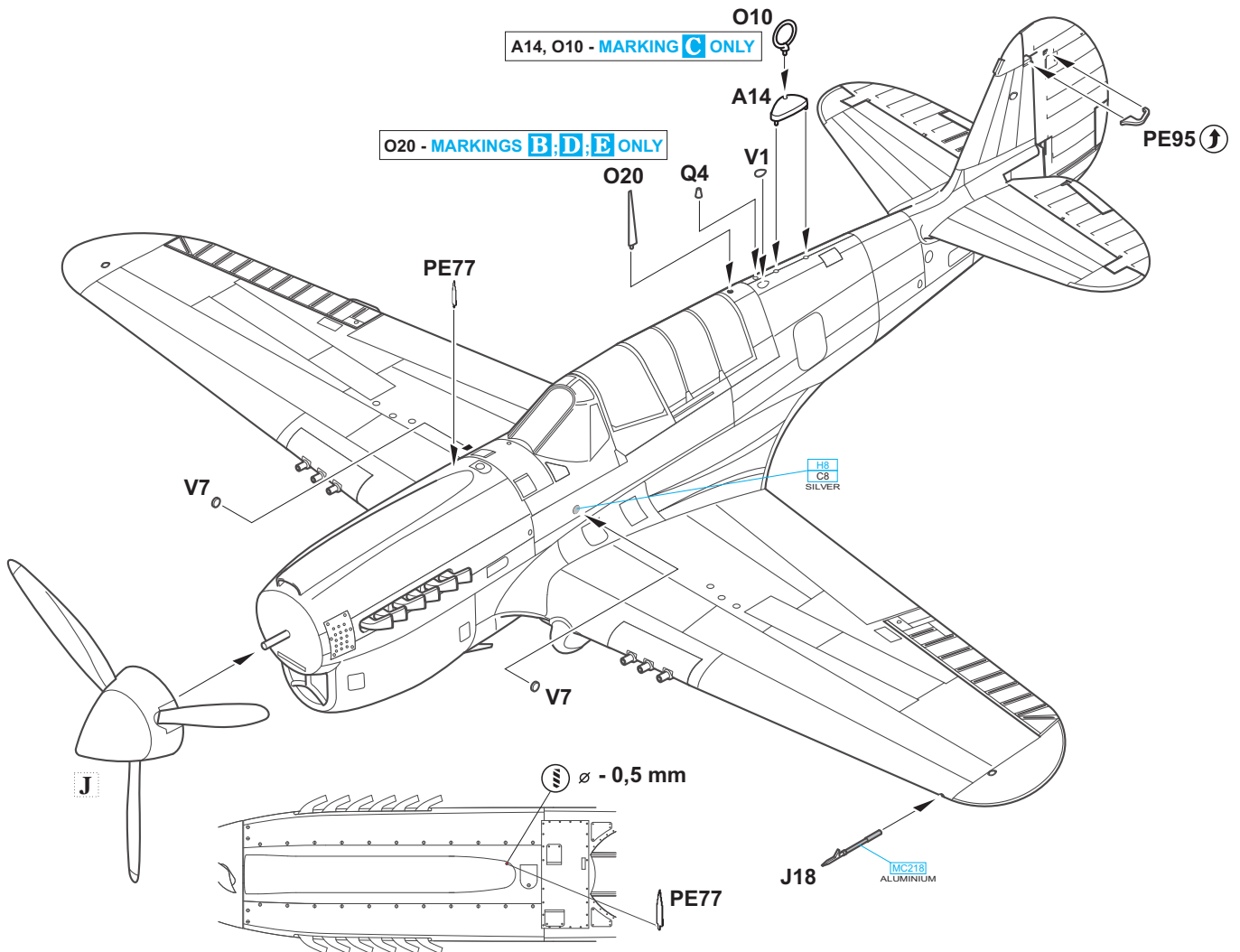

D P-40N, 7th FS, 49th FG, Cyclops Airfield, Hollandia, New Guinea, May 1944

Warhawks of the 49th FG were well known for their noseart, with scantily clad ladies being quite popular. The author of many of these was John Dunne. The aircraft with the port side inscription 'Daddy Please' and starboard side 'Milk Wagon Express' served with the 49th FG from the summer of 1943. Initially, the tactical number '10' was carried, which during the course of its career was changed to '00'. Although the name of the plane's pilot is not known, the number from 0 to 10 suggests, that it was someone from the command structure of the 49th FG. In the summer of 1944, the aircraft was transferred to the 82nd Tactical Reconnaissance Squadron, operating under the 71st TRG, and flew combat missions out of Biak Atoll. At that time, the spinner became yellow. The white leading edges of the wings were a quick recognition aid of friendly aircraft, a practice started by the 5th AF in the summer of '43.

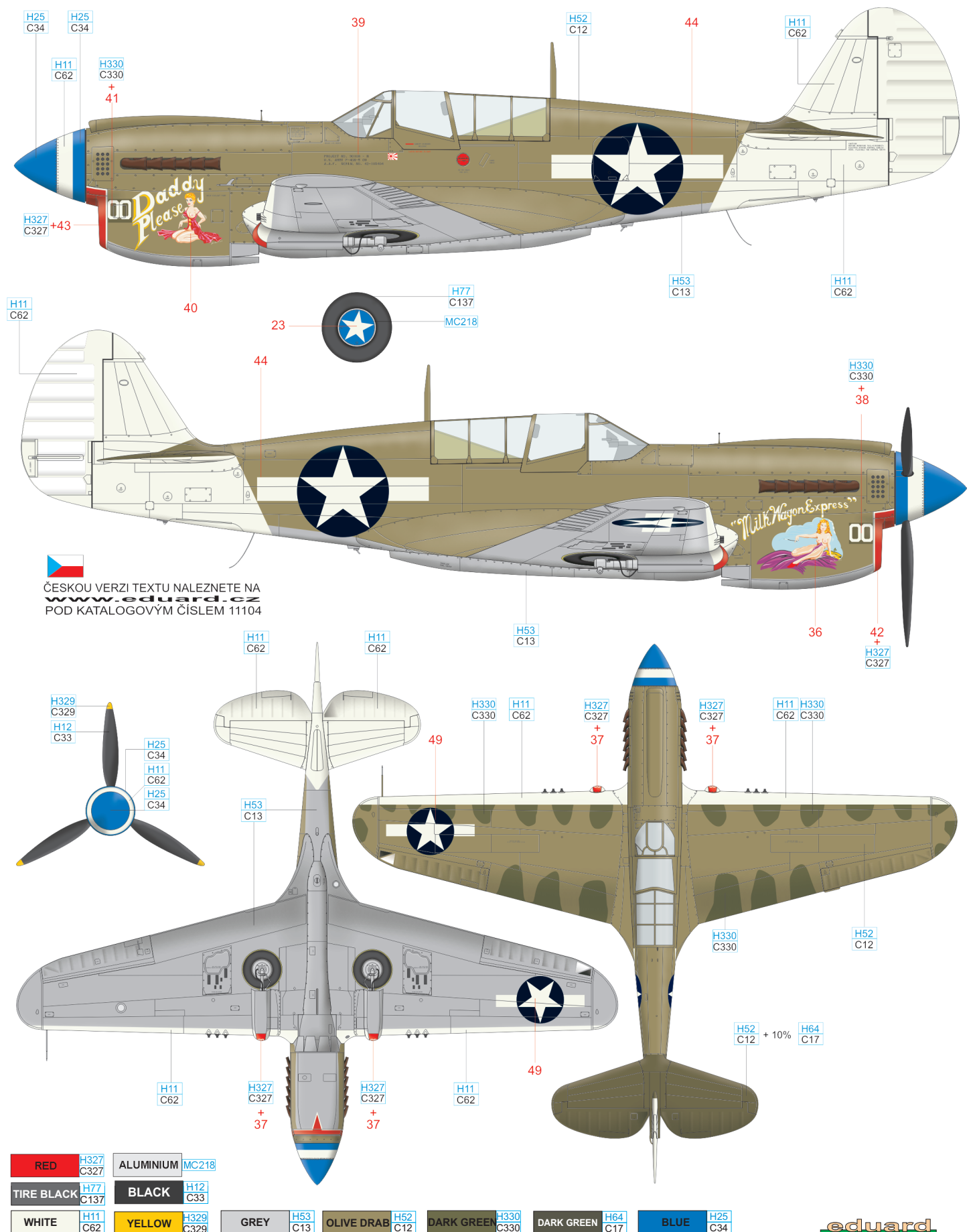

E Kittyhawk IV (P-40N-20), NZ3220, No. 18 Squadron RNZAF, Bougainville, 1944

Kittyhawk NZ3220 was the third New Zealand Air Force P-40N to carry the name 'Gloria Lyons' on the nose. The second of the so named aircraft, serialied NZ3167, was lost on February 22th, 1944 (thirteen days after first 'Gloria Lyons' Kittyhawk NZ3148, was lost with the same pilot at the controls!), when the gear retraction mechanism was rendered useless during a raid on a Japanese base and the pilot had to bail out over water off the island of Buka. The look of the inscription 'Gloria Lyons' on NZ3220 differed from its two predecessors. Below the windscreen, there were 2.5 kill marks and bombing mission markers in the form of yellow bomb silhouettes.

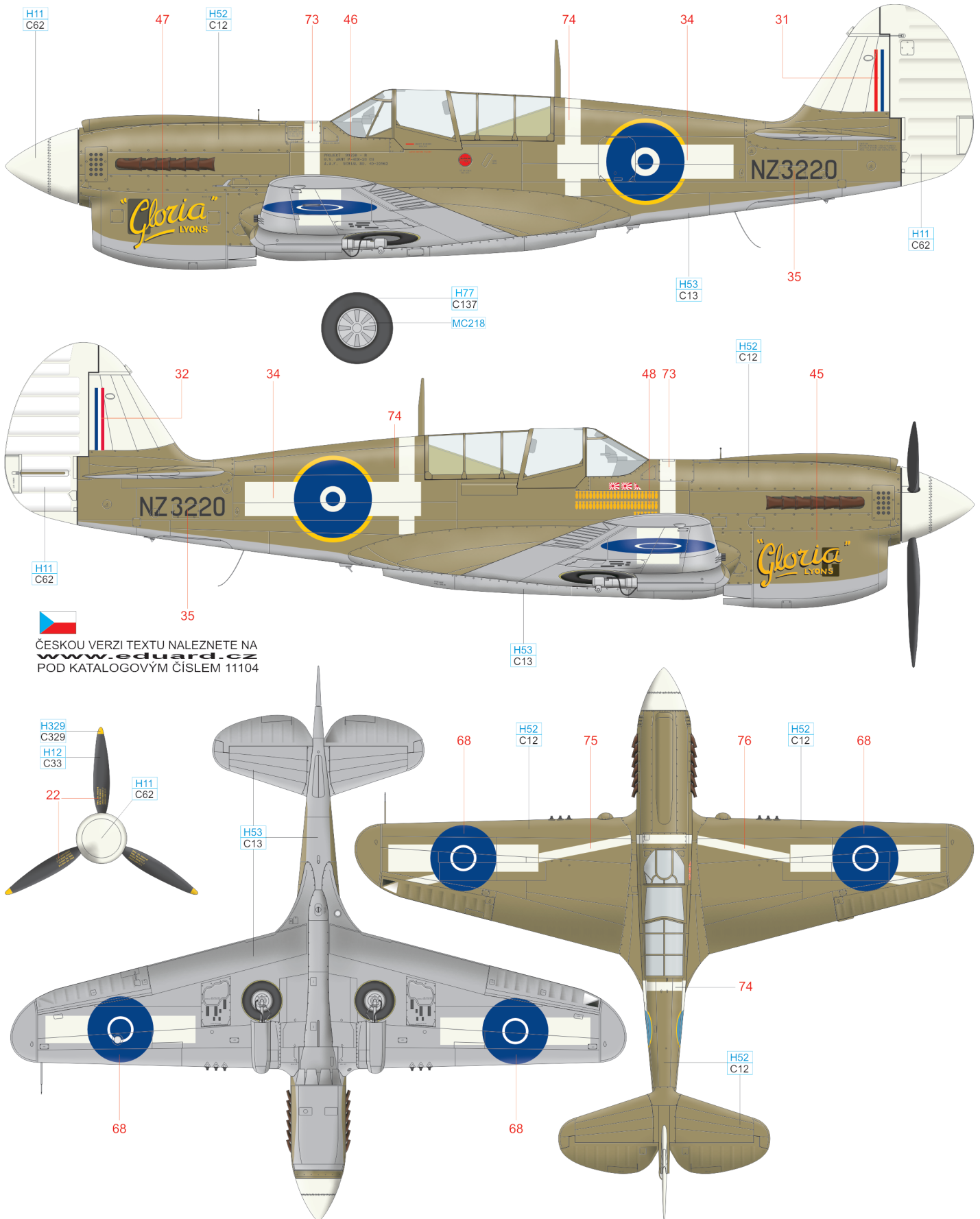

TIRE BLACK	H77 C137	BLACK	H12 C33
WHITE	H11 C62	YELLOW	H329 C329
		GREY	H53 C13
		OLIVE DRAB	H52 C12
		ALUMINIUM	MC218

