

**eduard**

LIMITED EDITION  
DUAL COMBO



**Z-126 Trenér**

INSTRUCTION SHEET

1/48

11156-NAV1

ATTENTION



UPOZORNĚNÍ



ACHTUNG



ATTENTION



注意



Carefully read instruction sheet before assembling. When you use glue or paint, do not use near open flame and use in well ventilated room. Keep out of reach of small children. Children must not be allowed to suck any part, or pull vinyl bag over the head.



Před započítím stavby si pečlivě prostudujte stavební návod. Při používání barev a lepidel pracujte v dobře větrané místnosti. Lepidla ani barvy nepoužívejte v blízkosti otevřeného ohně. Model není určen malým dětem, mohlo by dojít k požití drobných dílů.

INSTRUCTION SIGNS \* INSTR. SYMBOLS \* INSTRUKTION SINNBILDEN \* SYMBOLES \* 記号の説明

OPTIONAL  
VOLBABEND  
OHNOUTSAND  
BROUSITOPEN HOLE  
VYVRTAT OTVORSYMETRICAL ASSEMBLY  
SYMETRICKÁ MONTÁŽREMOVE  
ODŘÍZNOUTREVERSE SIDE  
OTOČITAPPLY EDUARD MASK  
AND PAINT  
POUŽIT EDUARD MASK  
NABARVIT

PARTS



DÍLY



TEILE



PIÈCES



部品

## PLASTIC PARTS

A&gt;

82180 A

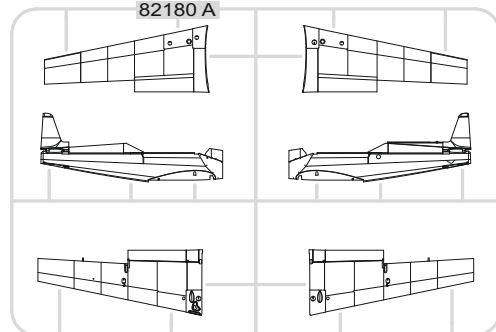

H&gt; 2 pcs.

82180 H

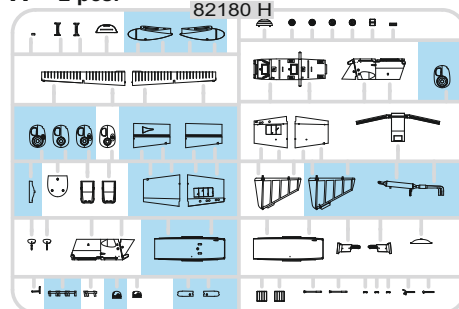

E&gt; 2 pcs.

82180 E

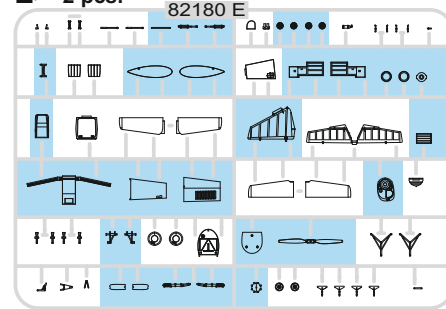

F&gt;

82180 F

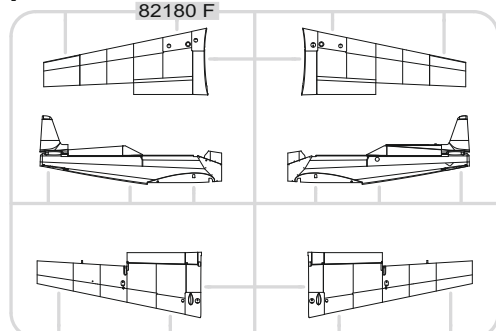

J&gt; 2 pcs.

82180 J

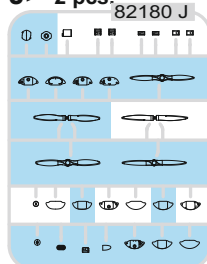

K&gt; 2 pcs.

82180 K

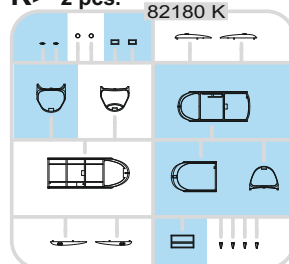
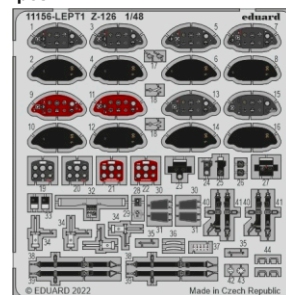
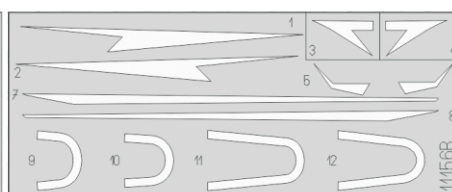
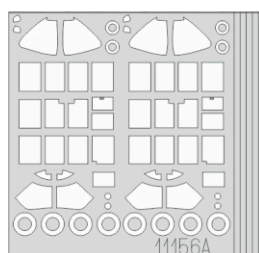
PE - PHOTO ETCHED DETAIL PARTS  
2 pcs.eduard  
MASK

-Parts not for use. -Teile werden nicht verwendet. -Pièces à ne pas utiliser. -Tyto díly nepoužívejte při stavbě. - 使用しない部品

COLOURS



BARVY



FARBEN



PEINTURE



色

| GSI Creos (GUNZE) |          | MISSION MODELS |               |
|-------------------|----------|----------------|---------------|
| AQUEOUS           | Mr.COLOR | PAINTS         |               |
| H1                | C1       | MMP-001        | WHITE         |
| H2                | C2       | MMP-047        | BLACK         |
| H3                | C3       | MMP-003        | RED           |
| H4                | C4       | MMP-007        | YELLOW        |
| H7                | C7       | MMP-002        | BROWN         |
| H8                | C8       |                | SILVER        |
| H11               | C62      | MMP-001        | FLAT WHITE    |
| H12               | C33      | MMP-047        | FLAT BLACK    |
| H13               | C3       | MMP-003        | FLAT RED      |
| H14               | C59      | MMP-005        | ORANGE        |
| H24               | C58      |                | ORANGE YELLOW |
| H25               | C34      |                | SKY BLUE      |
| H27               | C44      |                | TAN           |
| H33               | C81      |                | RUSSET        |
| H37               | C43      |                | WOOD BROWN    |
| H70               | C60      | MMP-056        | GRAY          |
| H77               | C137     | MMP-040        | TIRE BLACK    |
| H85               | C45      |                | SAIL COLOR    |
| H90               | C47      |                | CLEAR RED     |

| GSI Creos (GUNZE) |          | MISSION MODELS |                      |
|-------------------|----------|----------------|----------------------|
| AQUEOUS           | Mr.COLOR | PAINTS         |                      |
| H94               | C138     |                | CLEAR GREEN          |
| H303              | C303     | MMP-066        | GREEN                |
| H306              | C306     | MMP-118        | MEDIUM GRAY          |
| H307              | C307     | MMP-074        | GRAY                 |
| H308              | C308     | MMP-073        | GRAY                 |
| H310              | C310     | MMP-060        | BROWN                |
| H323              | C323     | MMP-092        | LIGHT BLUE           |
| H364              | C364     |                | GRAY GREEN           |
| H413              | C113     | MMP-090        | YELLOW               |
| H414              | C114     | MMP-003        | RED                  |
|                   | C74      | MMP-061        | AIR SUPERIORITY BLUE |
|                   | C158     |                | RED                  |
| Mr.METAL COLOR    |          | METALLICS      |                      |
| MC213             |          | MMM-006        | STAINLESS            |
| MC214             |          | MMM-001        | DARK IRON            |
| MC217             |          |                | GOLD                 |
| MC218             |          | MMM-003        | ALUMINIUM            |
| MC215             |          | MMM-004        | COPPER               |

**A** MARKINGS **A, E, H, I**

MARKINGS **B, C, D, G, J**

MARKING **F**

**B** plastic 2 pcs.

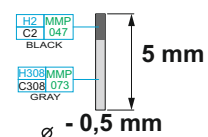
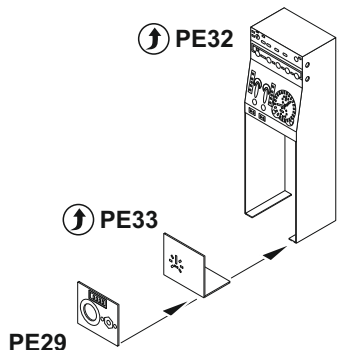
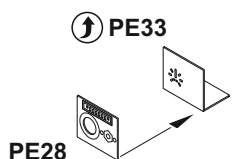
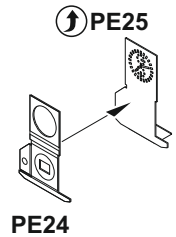

**C**

MARKING **J** ONLY

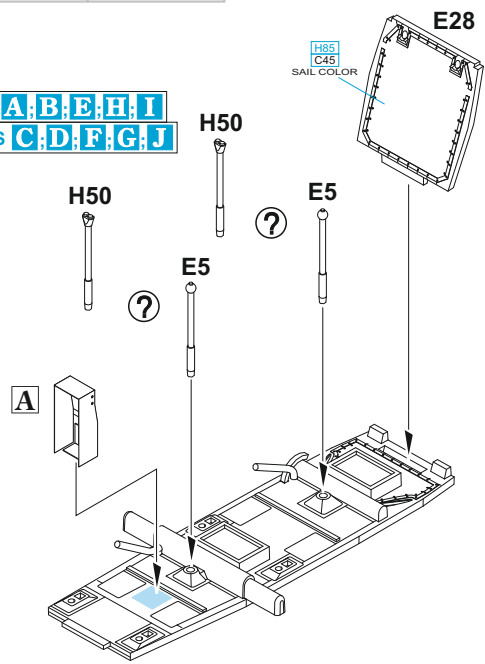
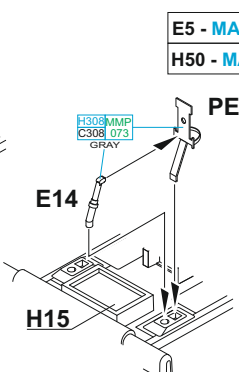
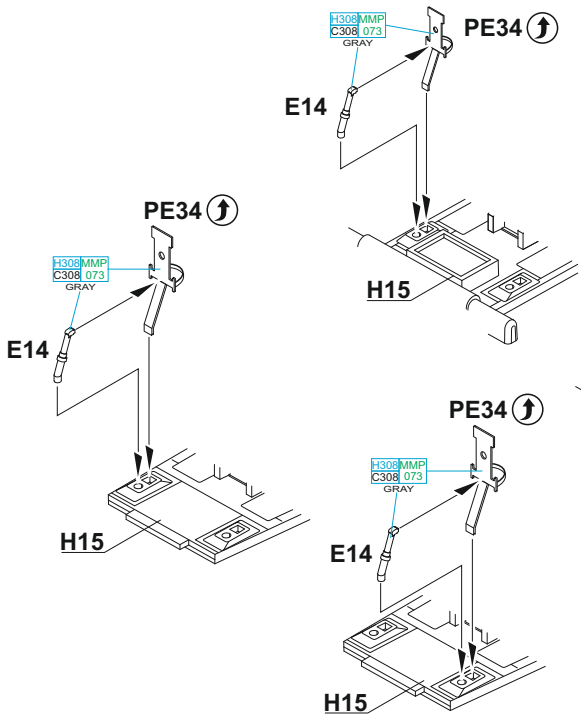
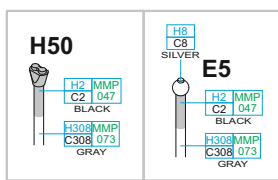
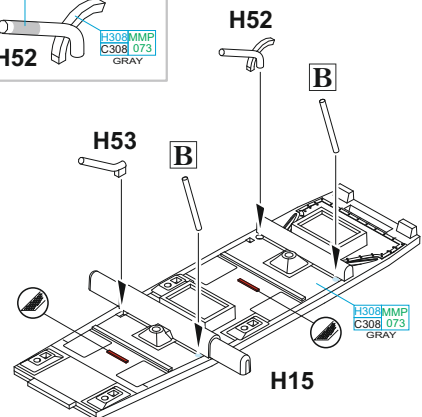
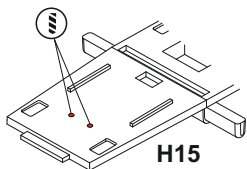
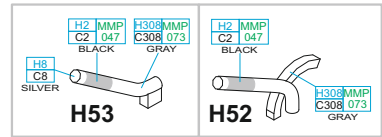
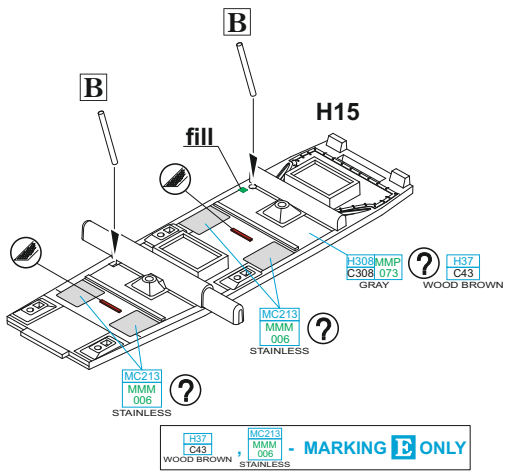

**E5 - MARKINGS A, B, E, H, I**

**H50 - MARKINGS C, D, F, G, J**

**B**

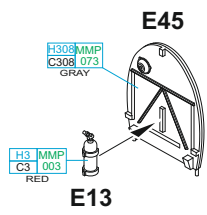

**H11 - MARKINGS B, C, D, F, G, J ONLY**

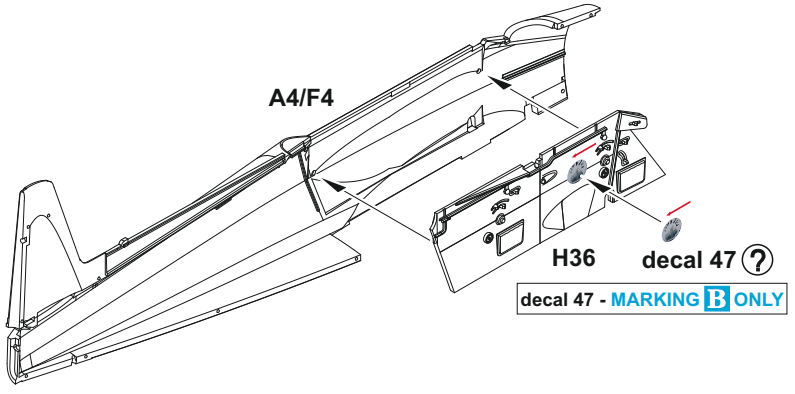
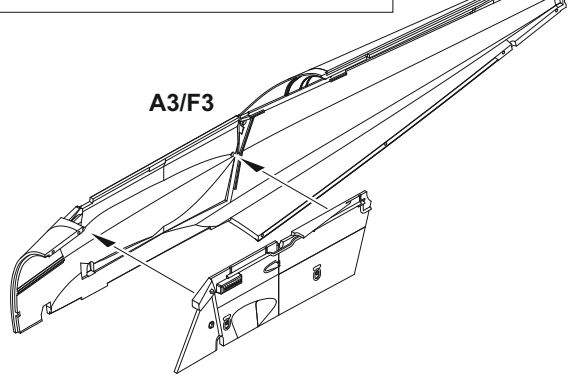
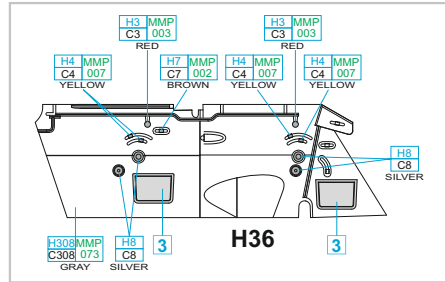
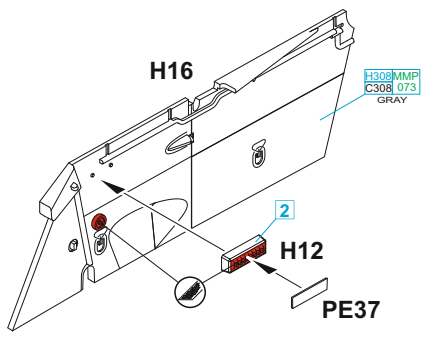
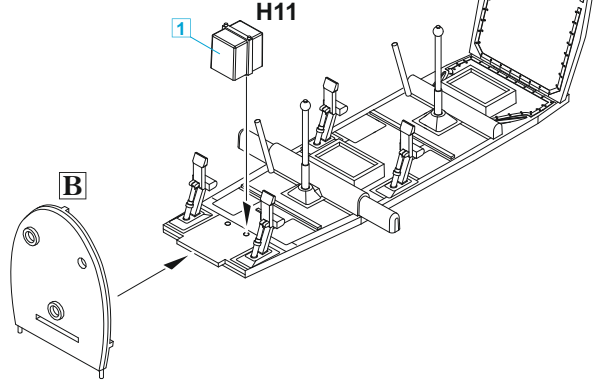

**D** H7 - MARKINGS B, D, F, G, H, I ONLY

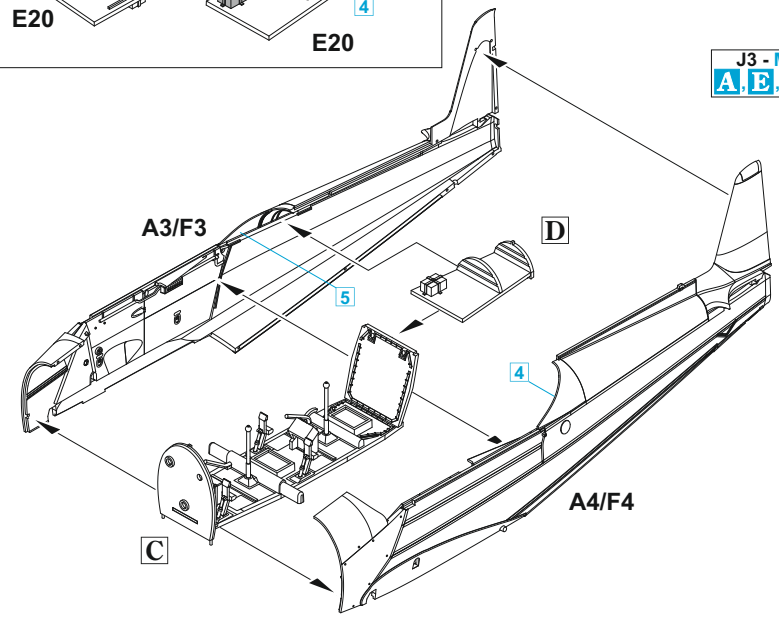
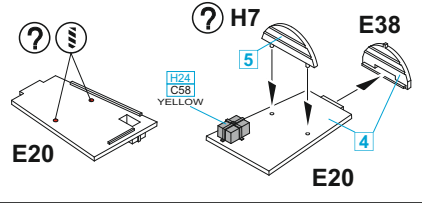

**J3 - MARKINGS A, E, H, I ONLY**

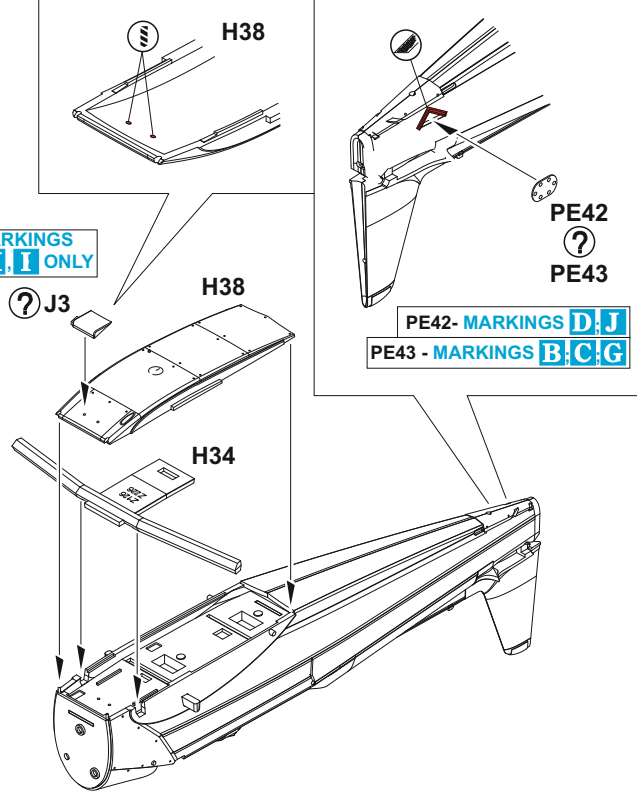

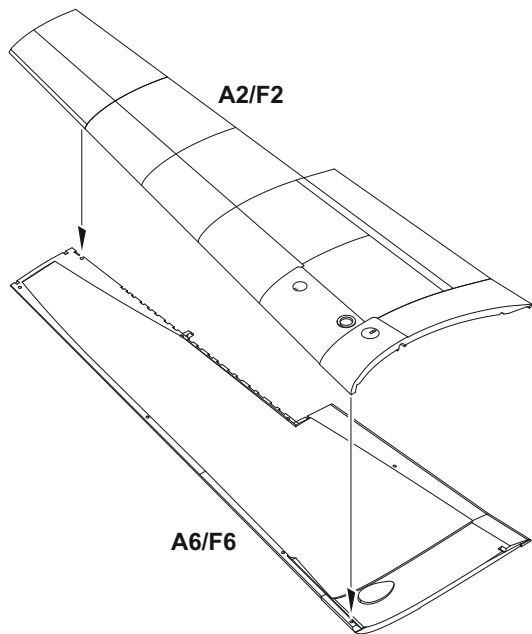
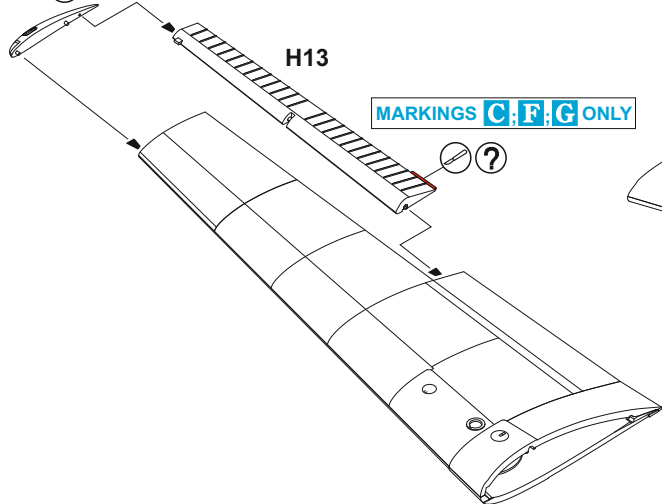
**E****K5 - MARKING G ONLY****K5 ? K14****MARKINGS C; F; G ONLY****F****MARKINGS A; E; F; H; I ONLY**

fill ?

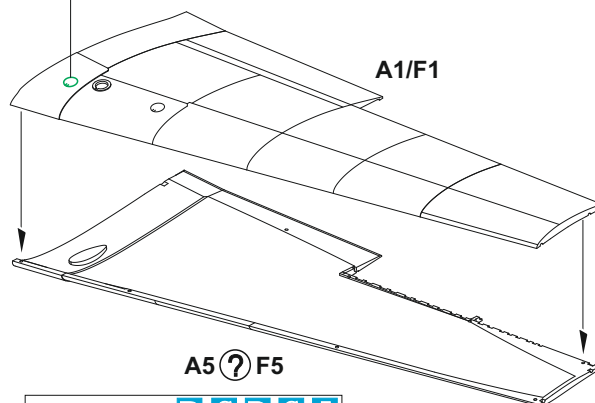
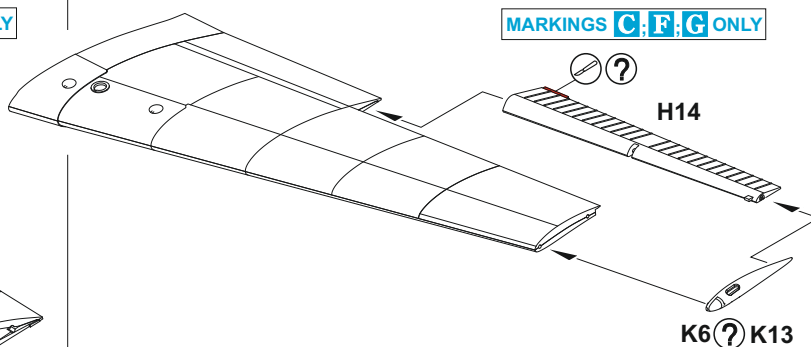
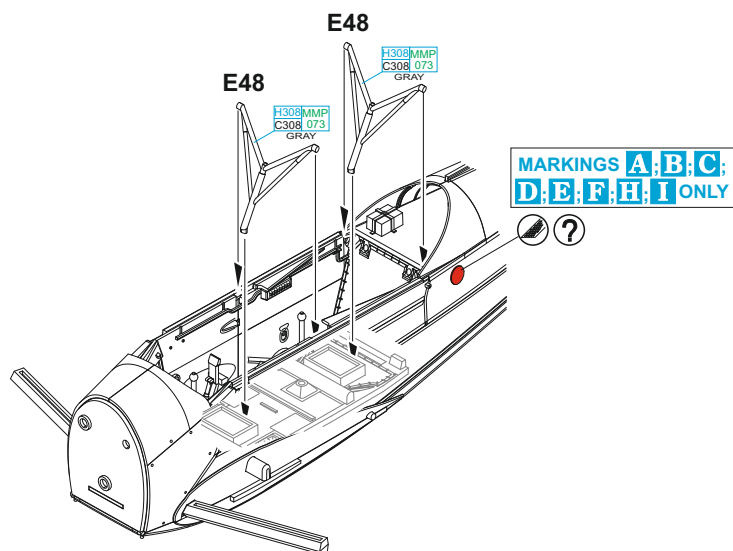
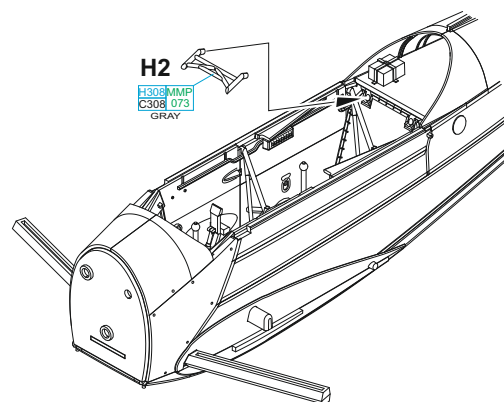
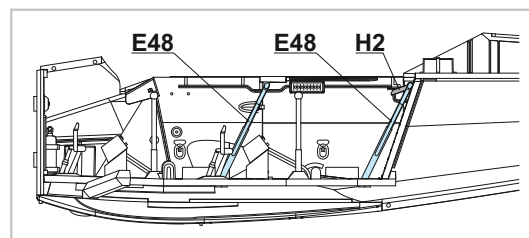
**A5 - MARKINGS B; C; D; G; J****F5 - MARKINGS A; E; F; H; I****MARKINGS C; F; G ONLY****H14****K6 ? K13****K6 - MARKING G ONLY****E48****H308MMP  
C308 073  
GRAY****E48****H308MMP  
C308 073  
GRAY****MARKINGS A; B; C;  
D; E; F; H; I ONLY****H2****H308MMP  
C308 073  
GRAY****E48****E48****H2**

**G** MARKING B

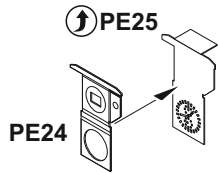

MARKINGS C,D,G

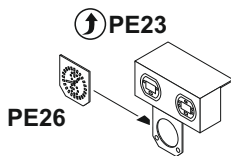

MARKING J



**H**

PE1, 2, 19 - MARKINGS A,B,C,D,E,I

PE5, 6, 19 - MARKINGS G,H

PE9, 10, 21 - MARKING F

PE13, 14, 19 - MARKING J

K16 - MARKINGS A,E,F,G,H,I

OPTIONAL:  
decal K1 ? K3 ? K5 ? K7

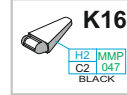
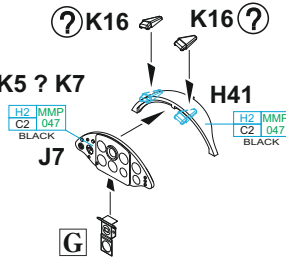
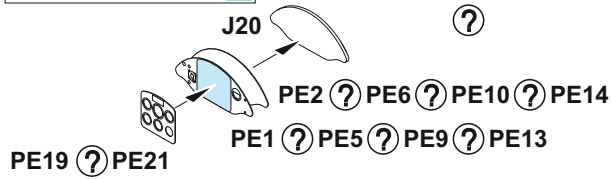

decal K1 - MARKINGS A,B,C,D,E,I

decal K3 - MARKINGS G,H

decal K5 - MARKING F

decal K7 - MARKING J

**I**

PE3, 4, 20 - MARKINGS A,B,C,D,E,I

PE7, 8, 20 - MARKINGS G,H

PE11, 12, 22 - MARKING F

PE15, 16, 20 - MARKING J

K16 - MARKINGS A,E,F,G,H,I

OPTIONAL:  
decal K2 ? K4 ? K6 ? K8

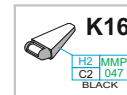
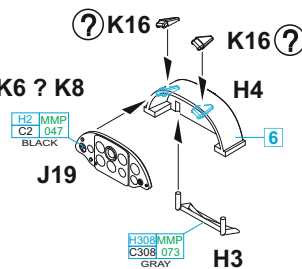
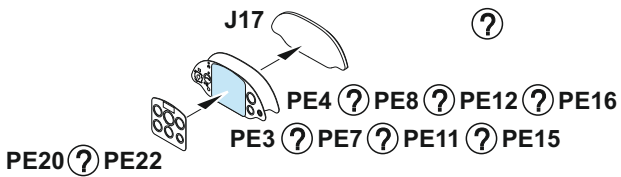

decal K2 - MARKINGS A,B,C,D,E,I

decal K4 - MARKINGS G,H

decal K6 - MARKING F

decal K8 - MARKING J

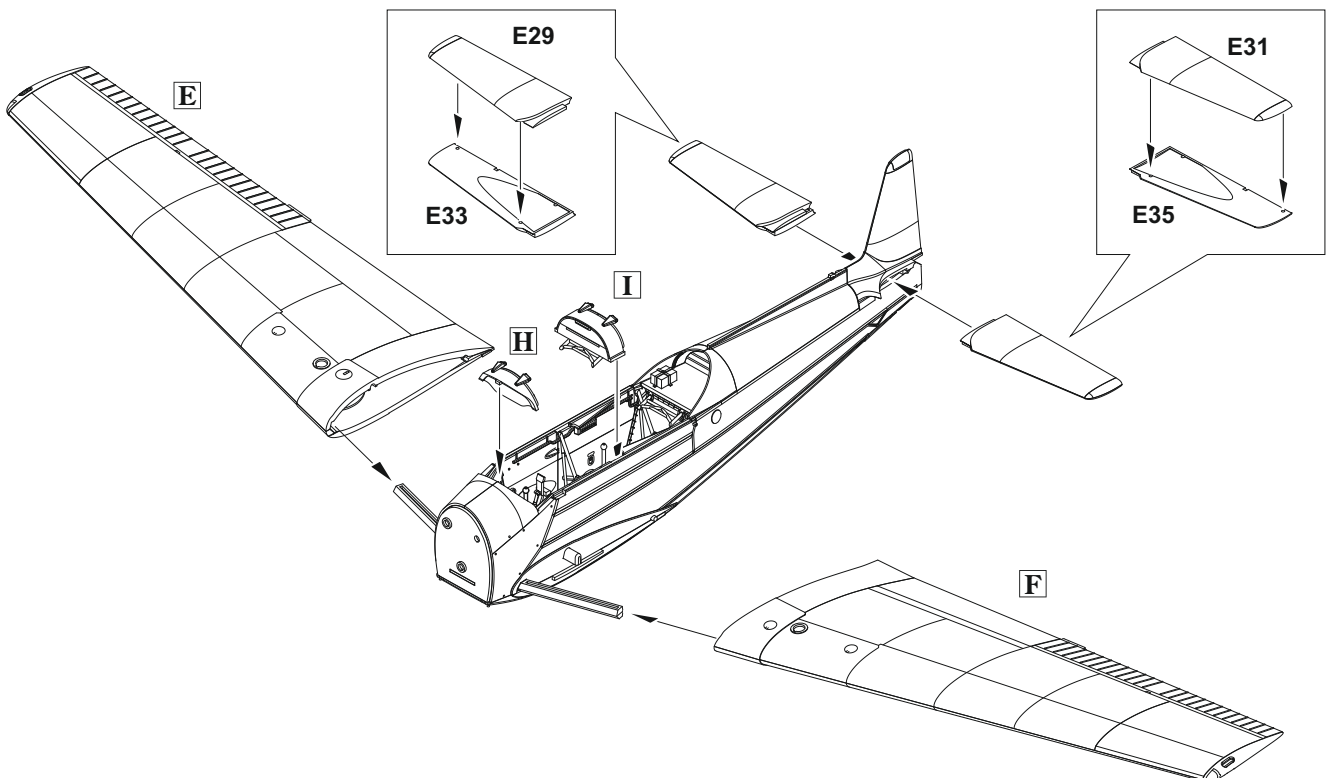

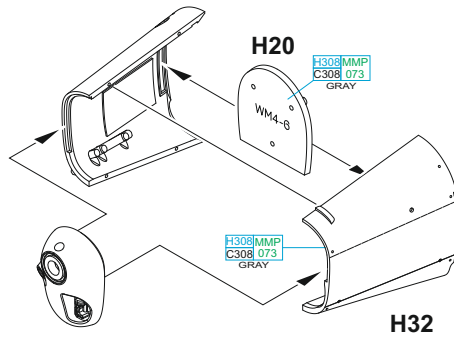
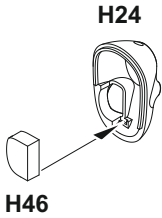
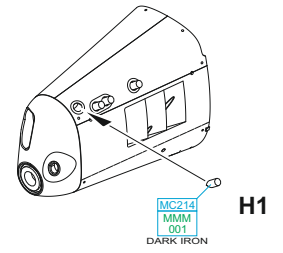
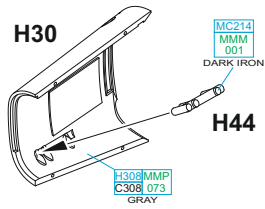
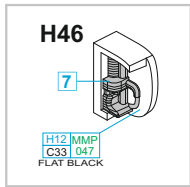
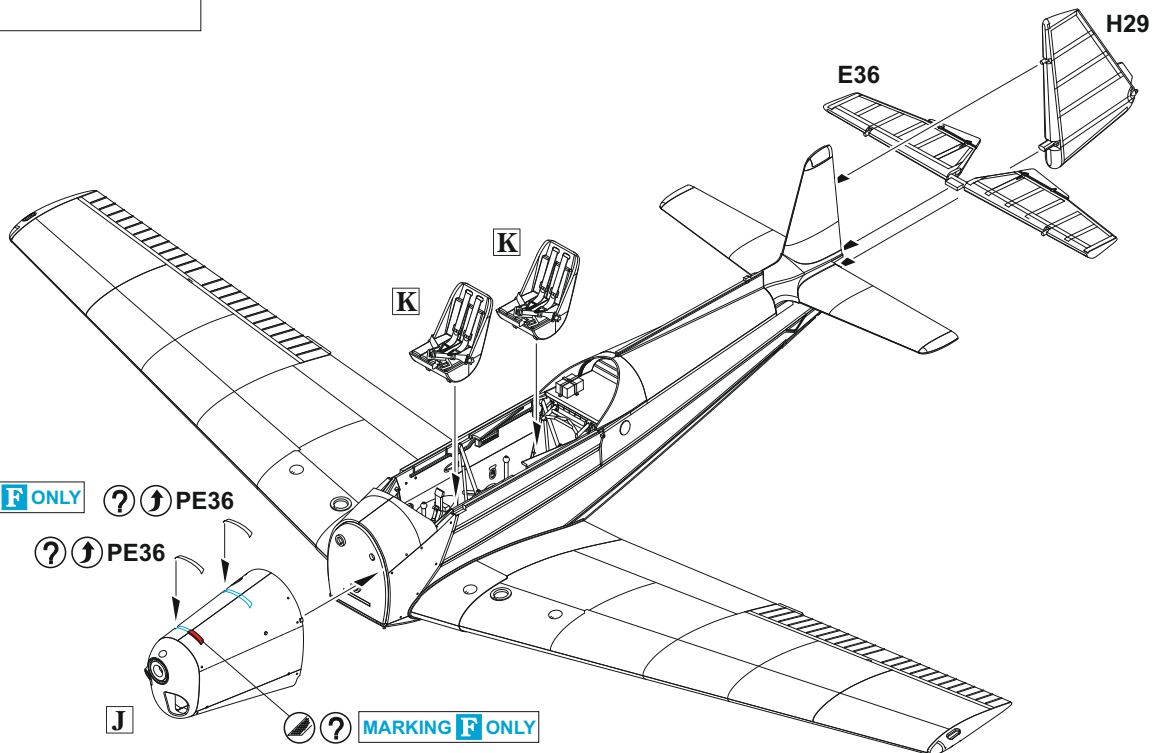
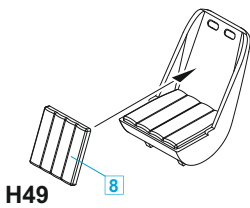
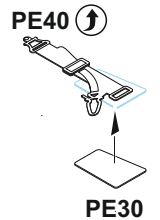
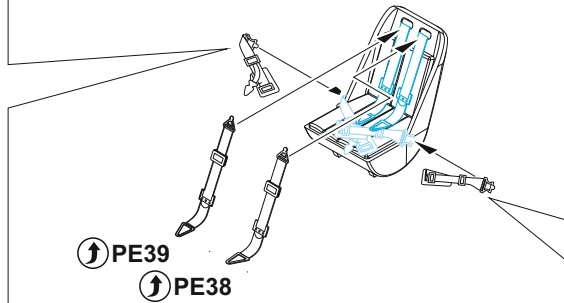
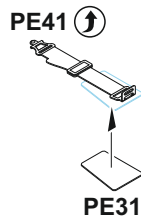
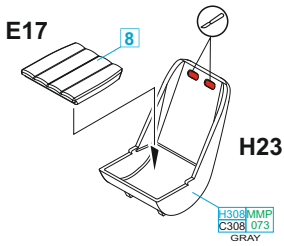
**J****K** 2 pcs.

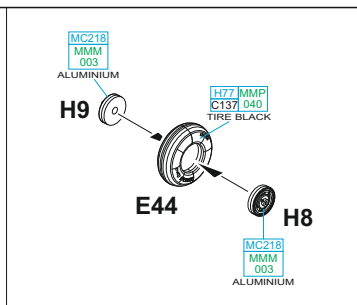
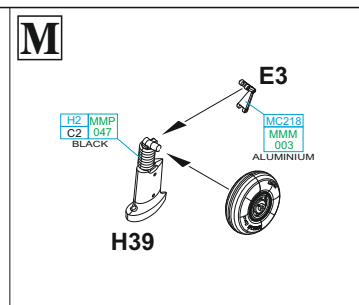
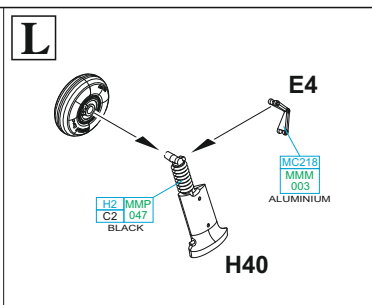
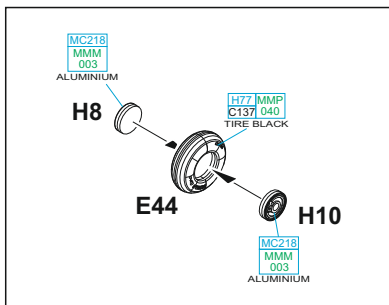

H35 - MARKINGS **A**; **B**; **E**; **F**; **H**; **I**  
 H59 - MARKINGS **C**; **D**; **G**; **J**

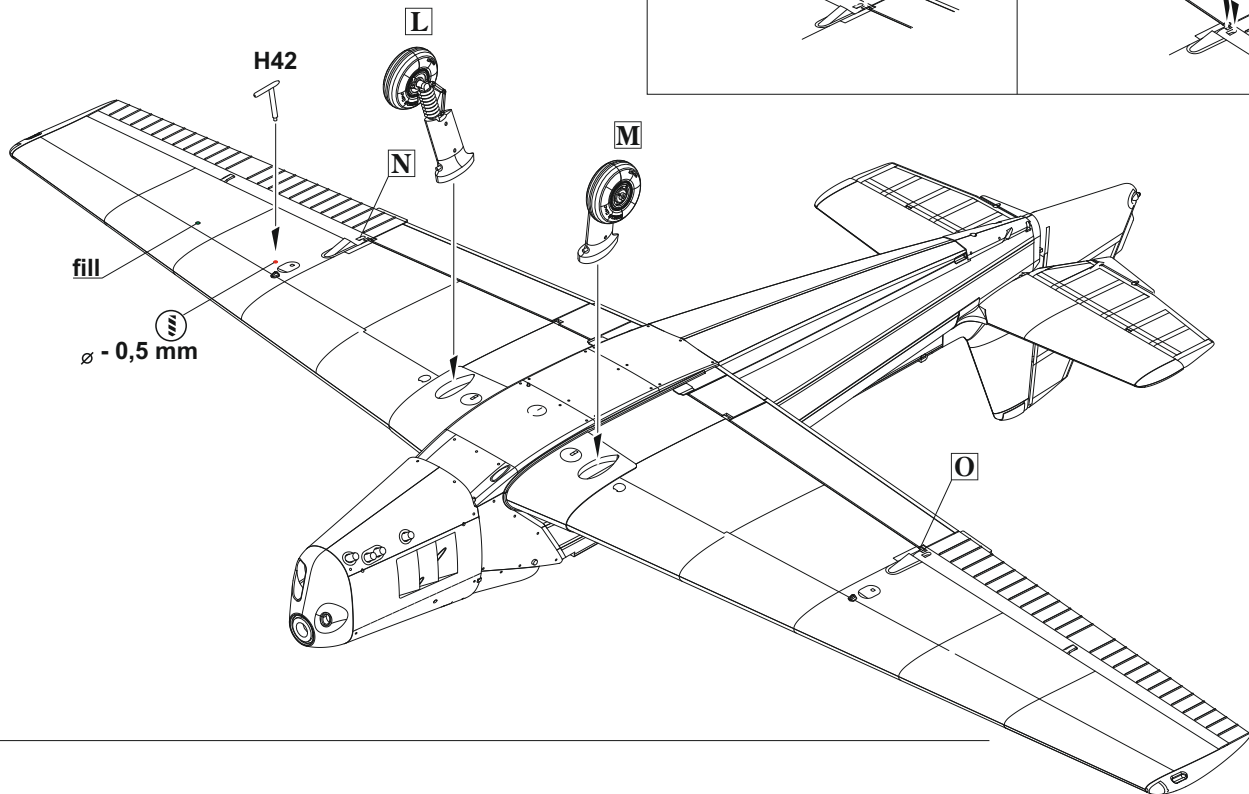
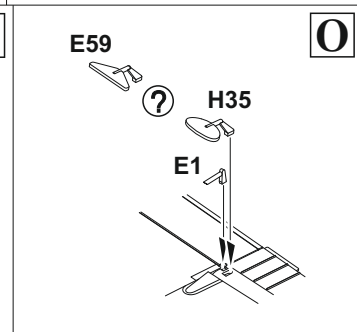
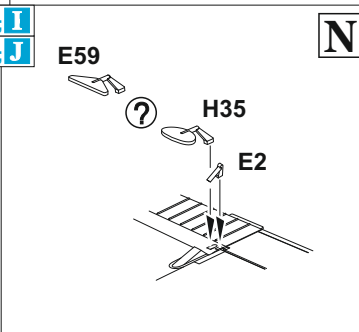

E50, E51 - MARKING **B** ONLY

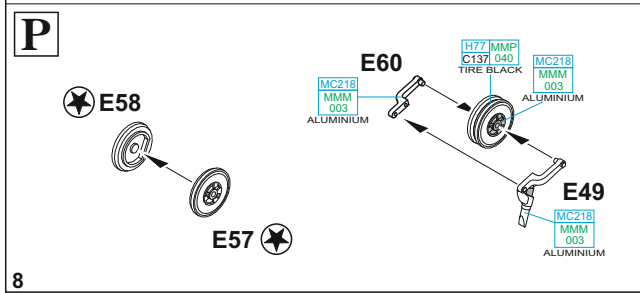
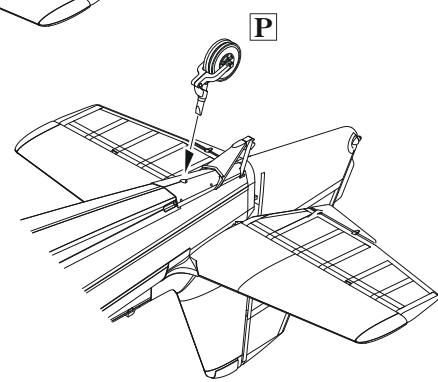
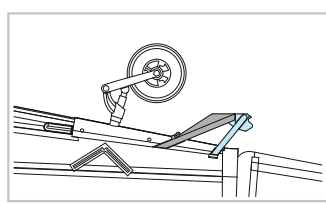
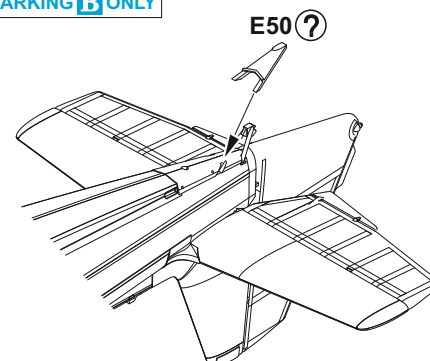
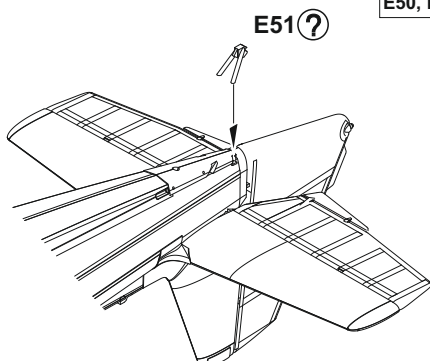

Q

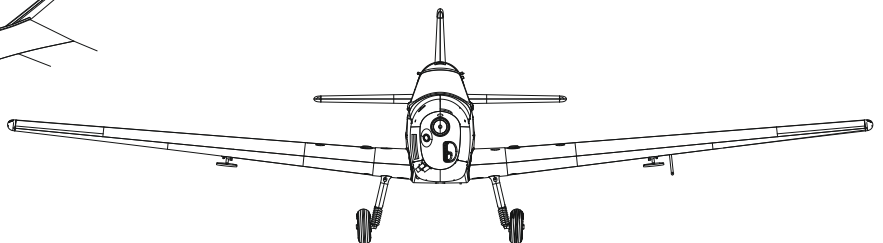
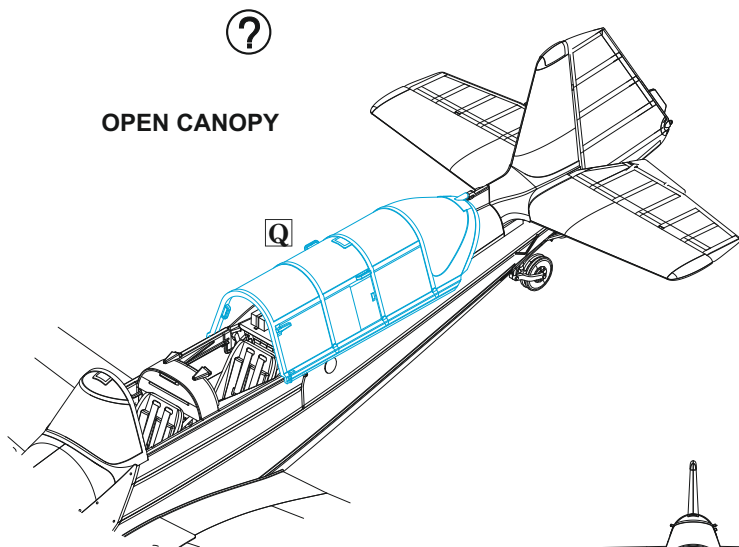
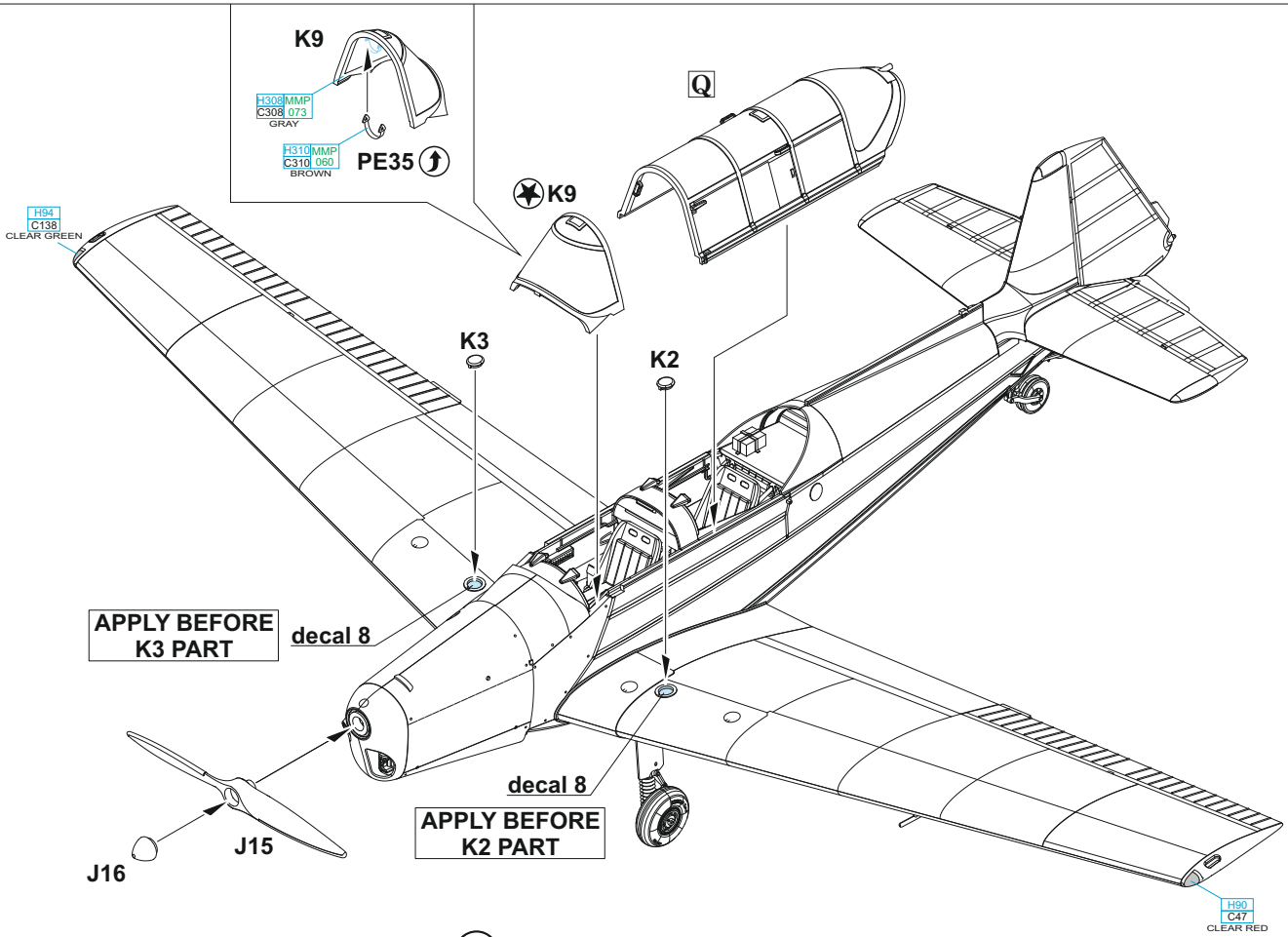
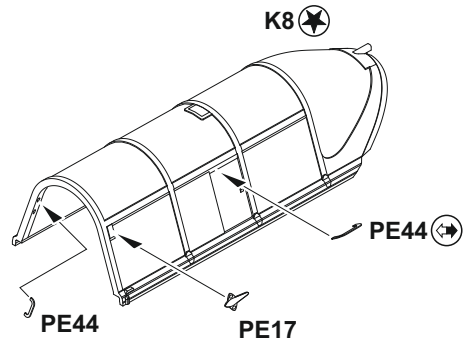
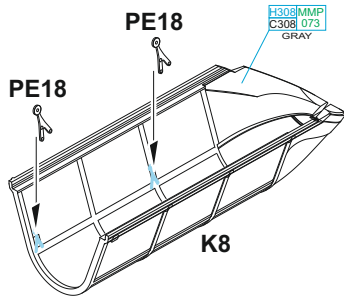

**1** =  $\begin{matrix} H2 & MMP & - & MARKING & B \\ C2 & 047 & - & & \\ H3 & MMP & - & MARKINGS & C,D,G,J \\ C3 & 003 & - & & \\ RED & & & & \end{matrix}$

**2** =  $\begin{matrix} H2 & MMP & - & MARKING & G \\ C2 & 047 & - & & \\ H3 & MMP & - & MARKINGS & A,B,C,D,E,F,H,I,J \\ C3 & 073 & - & & \\ GRAY & & & & \end{matrix}$

**3** =  $\begin{matrix} H2 & MMP & - & MARKINGS & B,C,D,I,J \\ C2 & 047 & - & & \\ H3 & MMP & - & MARKINGS & A,E,F,G,H \\ C3 & 081 & - & & \\ RUSSET & & & & \end{matrix}$

**4** =  $\begin{matrix} H37 & - & MARKING & F \\ C43 & - & & \\ H308 & MMP & - & MARKINGS & A,B,C,D,E,G,H,I,J \\ C308 & 073 & - & & \\ GRAY & & & & \end{matrix}$

**5** =  $\begin{matrix} H11 & MMP & - & MARKING & F \\ C1 & 001 & - & & \\ H308 & MMP & - & MARKINGS & A,B,C,D,E,G,H,I,J \\ C308 & 073 & - & & \\ GRAY & & & & \end{matrix}$

**6** =  $\begin{matrix} H2 & MMP & - & MARKINGS & A,C,G,J \\ C2 & 047 & - & & \\ H307 & MMP & - & MARKING & D \\ C307 & 074 & - & & \\ GRAY & & & & \\ H308 & MMP & - & MARKINGS & B,D,E,F,H,I \\ C308 & 073 & - & & \\ GRAY & & & & \end{matrix}$

**7** = 90%  $\begin{matrix} M0218 & - & \\ MM1 & 003 & - & \\ ALUMINIUM & & & \end{matrix}$  + 10%  $\begin{matrix} M0217 & - & \\ GOLD & & & \end{matrix}$

**8** =  $\begin{matrix} H3 & MMP & - & MARKING & J \\ C3 & 003 & - & & \\ H33 & MMP & - & MARKINGS & A,F,G,H,I \\ C31 & - & - & & \\ RUSSET & & & & \\ H308 & MMP & - & MARKINGS & B,C,E,H \\ C308 & 118 & - & & \\ MEDIUM & GRAY & & & \end{matrix}$

**eduard**  
**MASK**  
**11156 A**

**eduard**  
**MASK**  
**11156 B**

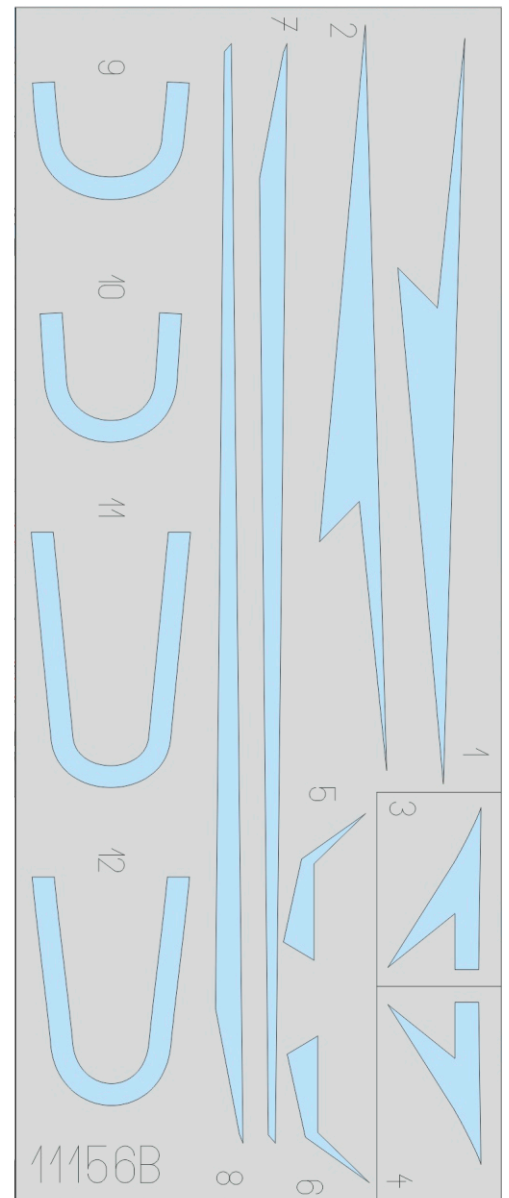
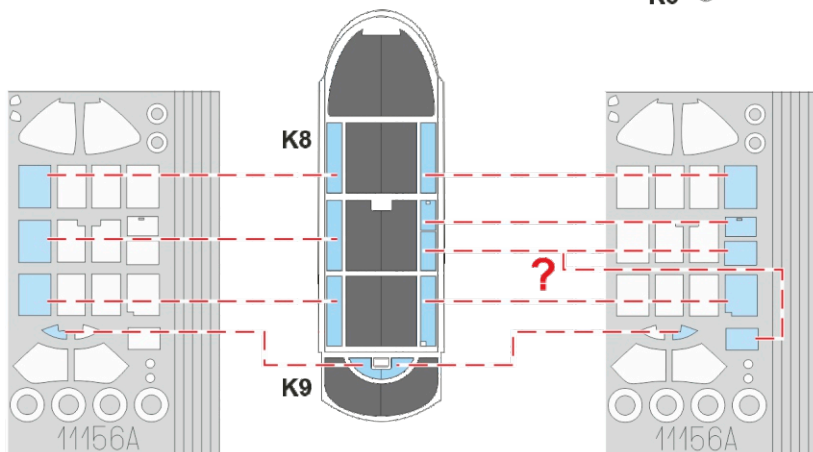
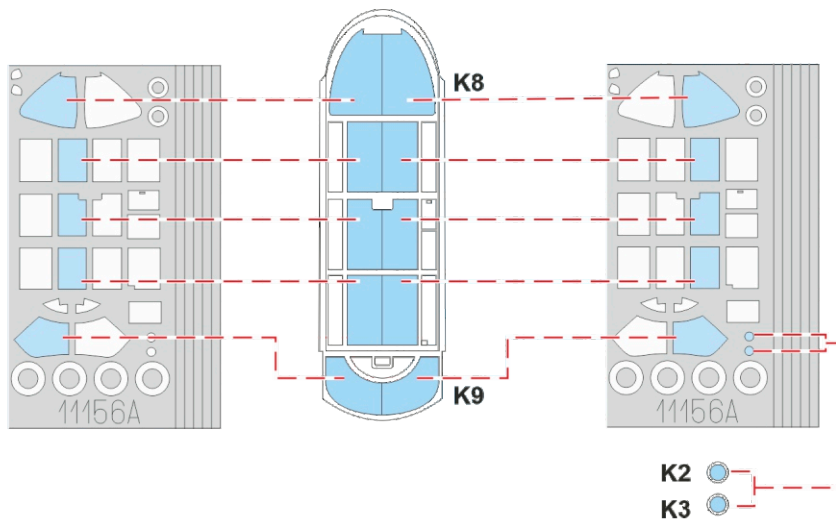
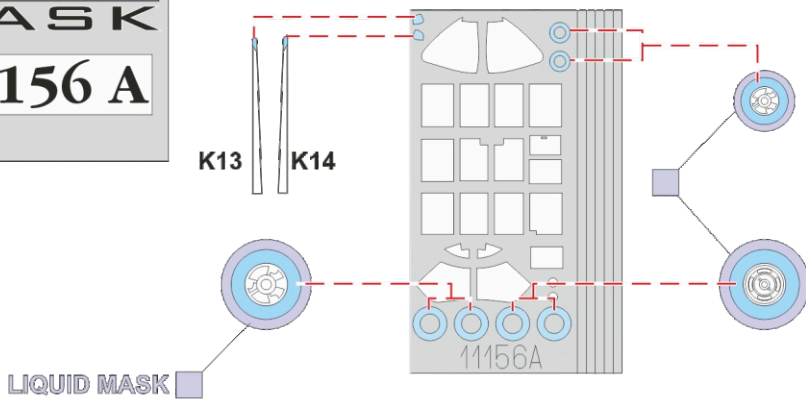

# A Z-126, OK-JGT, No. 804, Ruzyně Aero Club, 1960

The "Yoghurt", as the aircraft is nicknamed due to its matriculation, was manufactured in 1954 and on February 15, 1955 it was handed over to the Ministry of Defence for pilot training purposes. Later was handed over to the Svazarm organization (Union for civilian cooperation with army) and was operated mainly by Aero Clubs of Zbraslavice, Ruzyně or Letňany. Its career as Z-126 version ended in 1982 and it was stored disassembled in the Letňany hangar. In 1998, OK-JGT underwent general overhaul and was also upgraded to the Z-226MS version by ZLIN-AVION Service company. At that time, "Yoghurt" also received a livery with yellow-red triangles. The historical livery of OK-JGT as Z-126 was based on the scheme used for the Z-226A/AS aerobatic specials, with light blue color instead the white one.

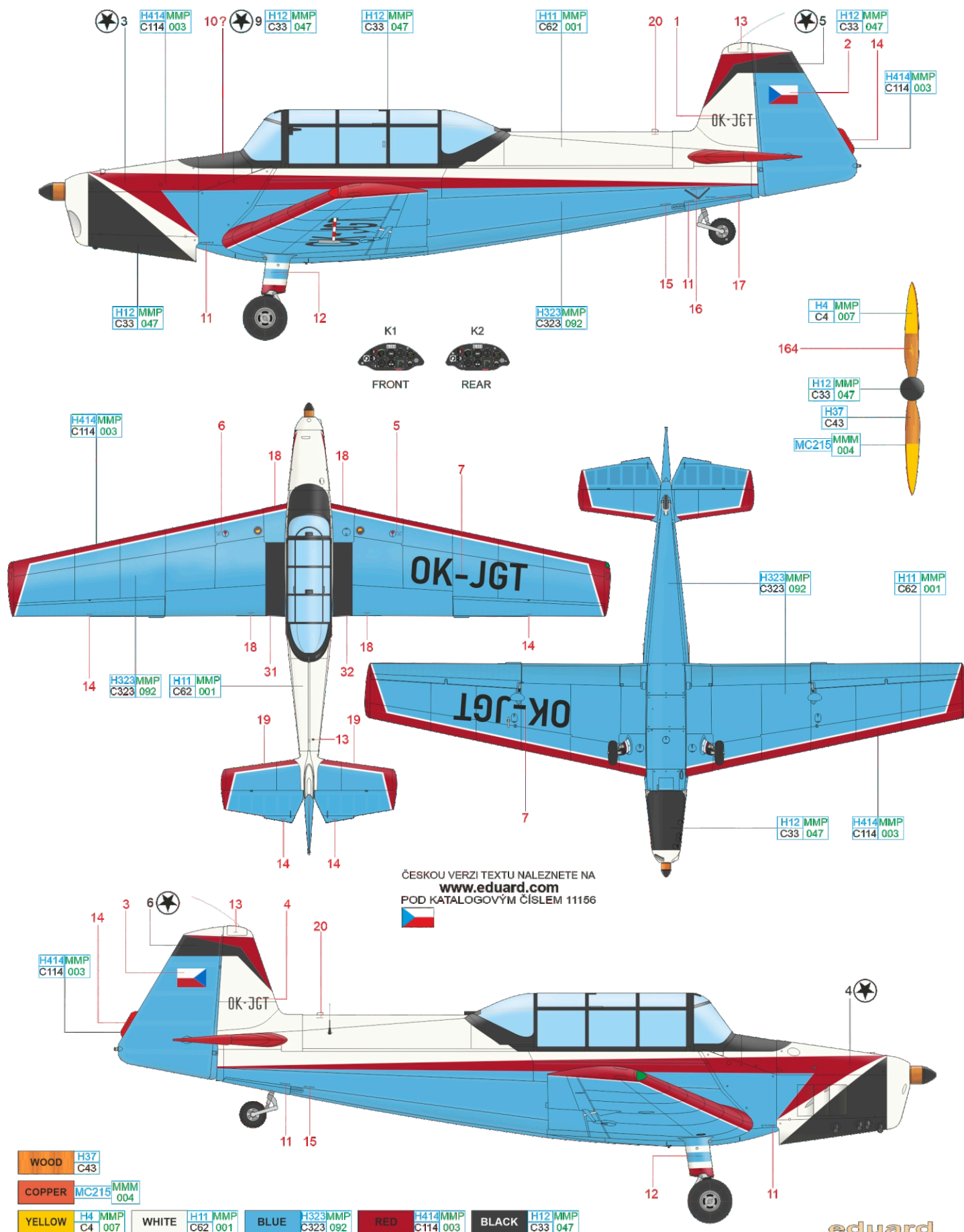

# B Z-126, OK-DVG, No. 525, Příbram Aero Club, September 2021

This aircraft was produced as Z-26 on August 30, 1950. As it was 38<sup>th</sup> aircraft of this type manufactured, it got military marking code UC-38 and served with military from 1950 to 1954. After that the aircraft was assigned to the Liberec Aero Club, converted to the Z-126 version and registered as OK-DVG on April 22, 1955. It flew like this until 1966, when it was considered too old and put out of service. Eventually it was noticed by František Altner, a Czechoslovak Airlines pilot, who brought the incomplete aircraft. He made overhaul of it on his own and registered it as OK-EKA at the end of 1970. When Ladislav Bezák emigrated at the end of 1971, however, Altner was banned to use the aircraft and sold it to the Svazarm (Union for civilian cooperation with army). In 1976, the aircraft underwent another overhaul and flew with the Aero Clubs in the Central Bohemia region, mainly at the airfields of Točná, Kladno and Příbram until 1981, when it was de-registered again due to its age. Thanks to the efforts of the members of Příbram Aero Club it was overhauled again in the mid-1990s by ZLIN-AVION Service and got its original markings. It was test-flown on September 2, 1997 and is in use by Příbram Aero Club until today. It is the only Trener that has retained manual crank start and is the oldest airworthy one as well.

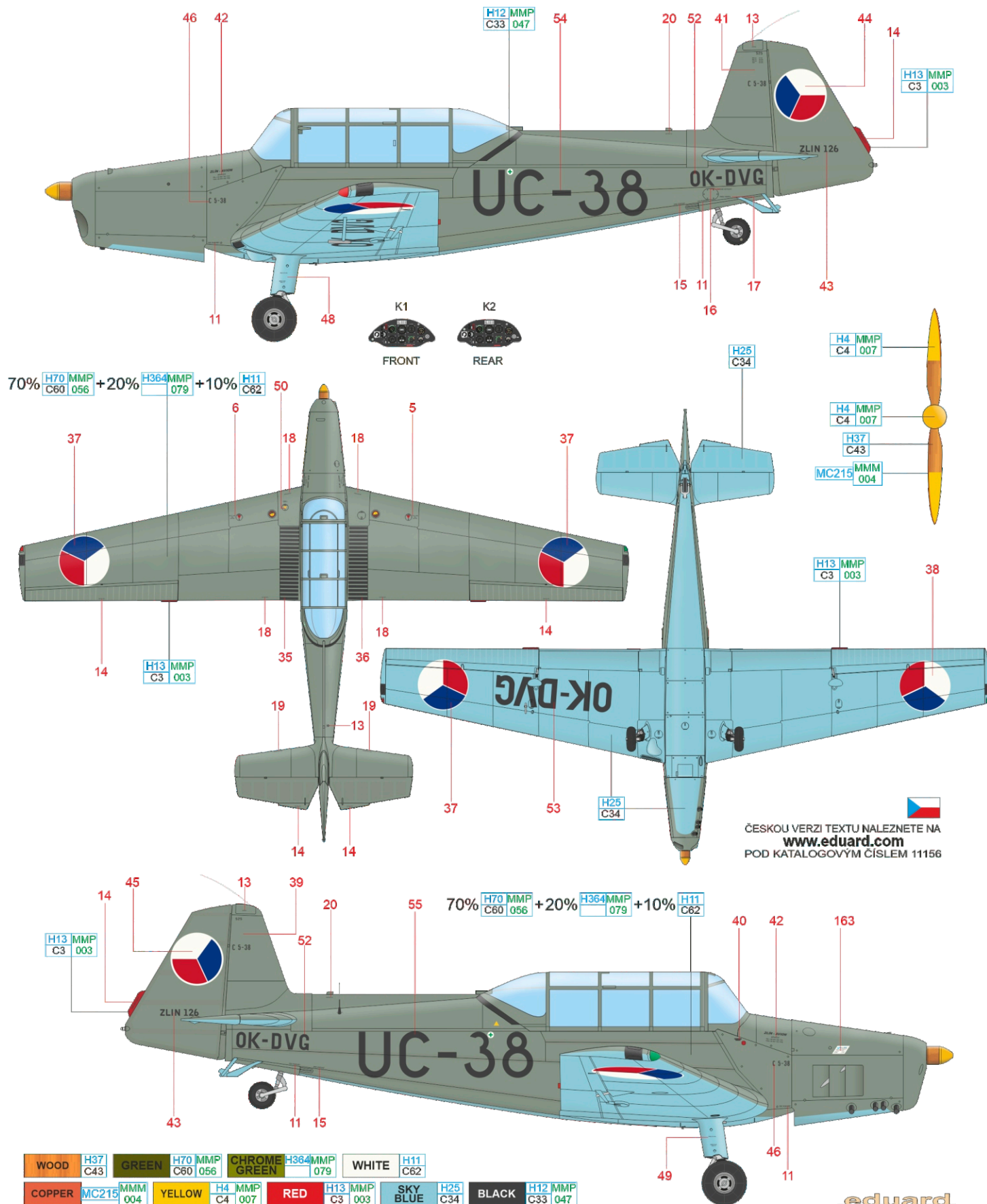

ČESKOU VERZI TEXTU NALEZNETE NA  
[www.eduard.com](http://www.eduard.com)  
 POD KATALOGOVÝM ČÍSLEM 11156

# C Z-126, OK-JHD, No. 817, private owners, Chotěboř airfield, 2021

This Z-126 was test-flown on March 3, 1955 and stored afterwards until February 1, 1957. At that time it was given the OK-JHD matriculation, and the military commission took over this trainer a week later. It was then used by Regional Aero Club Liberec. Due to its intense service, it had to undergo its first overhaul in 1959 by LOTN (Trenčín Aircraft Repairs). The second overhaul followed in 1966 and the third in 1974, this time at Aerotechnik Kunovice, where the aircraft received a brick orange livery with a dark red stripe. In this form it was serving until September 1979. A year later it was deleted from the register and remained disassembled in the hangar of the Liberec Aero Club where over the years became a spare parts source. Then, two members of the Chotěboř Aero Club found it there some 20 years later and decided to buy it and make it to fly again. They also wanted their Trainer to be given a historically accurate marking. Their first choice was the design in which the Z-126 OK-IMB flew in the 1970's in Chotěboř and neighbor Aero Clubs. However, as they lacked good reference materials, the choice fell on the color scheme based on the coloring of the aircraft of the famous Olomouc woman aerobatic group which was flying in 1957. The OK-JHD was test-flown in this form on October 13, 2007 in Otrokovice. Since then, it has been operated on the Chotěboř airfield and used not only by its owners but also by other pilots of the local Aero Club.

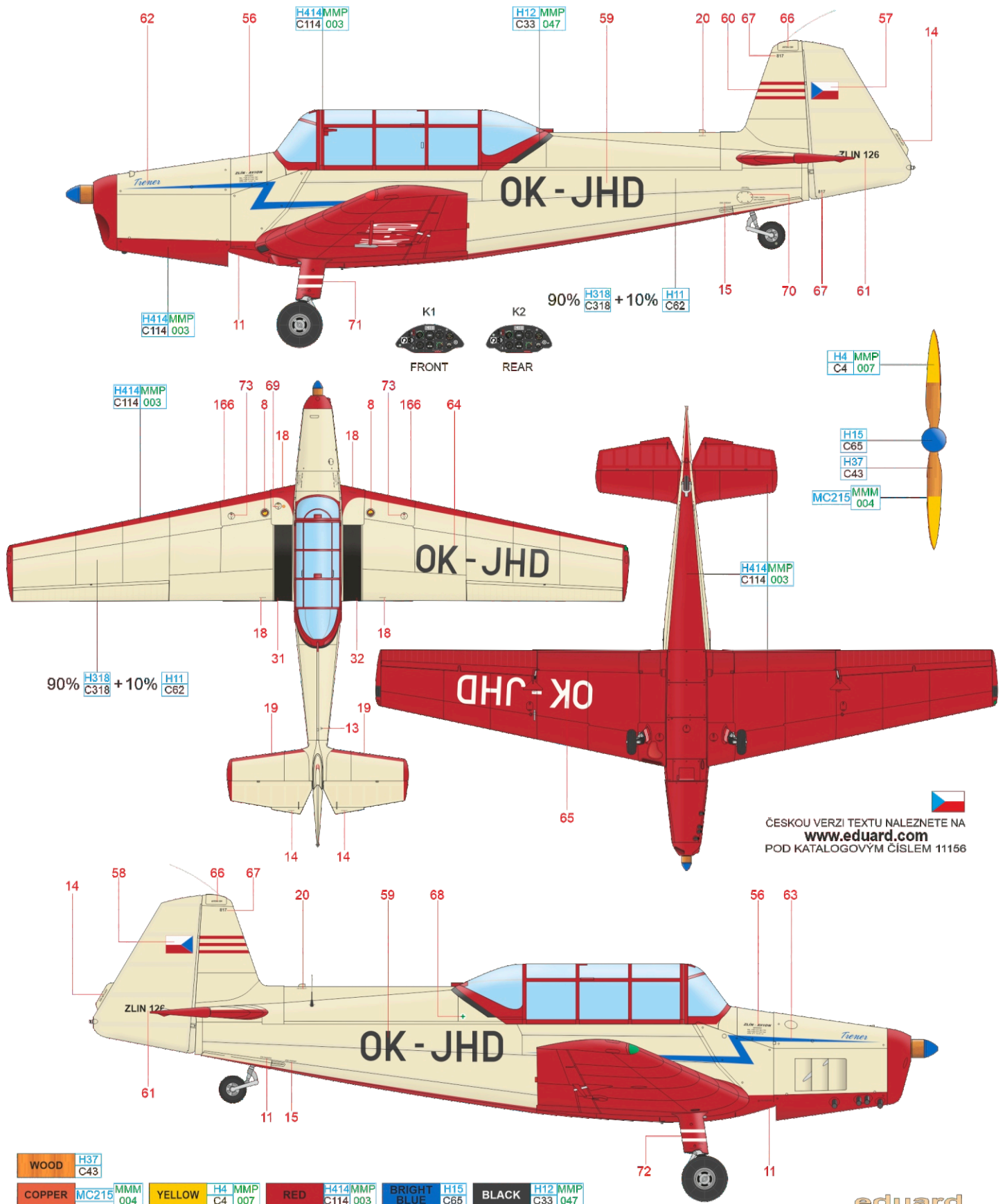

# D Z-126, D-EYGL, No. 796, private owner, Straubing Airport, Germany, 2020

The aircraft was manufactured in 1954 with wooden tail surfaces, but already as Z-126. It was handed over to the Svazarm (Union for civilian cooperation with army) on December 17 the same year. From that time on it was serving with Kralupy nad Vltavou, Gottwaldov and Holešov Aero Clubs (there until 1978). In 1992 it was bought by Emmax Uherské Hradiště company and a year later sold to a private owner from Strážnice. After overhaul by ZLIN-AVION Service in 1994, the OK-IGL was operated at Kunovice airfield and changed hands again around 2000. After a few years the owner sold it to German taker and the aircraft was given German matriculation D-EYGL, as more appropriate D-EIGL was not available.

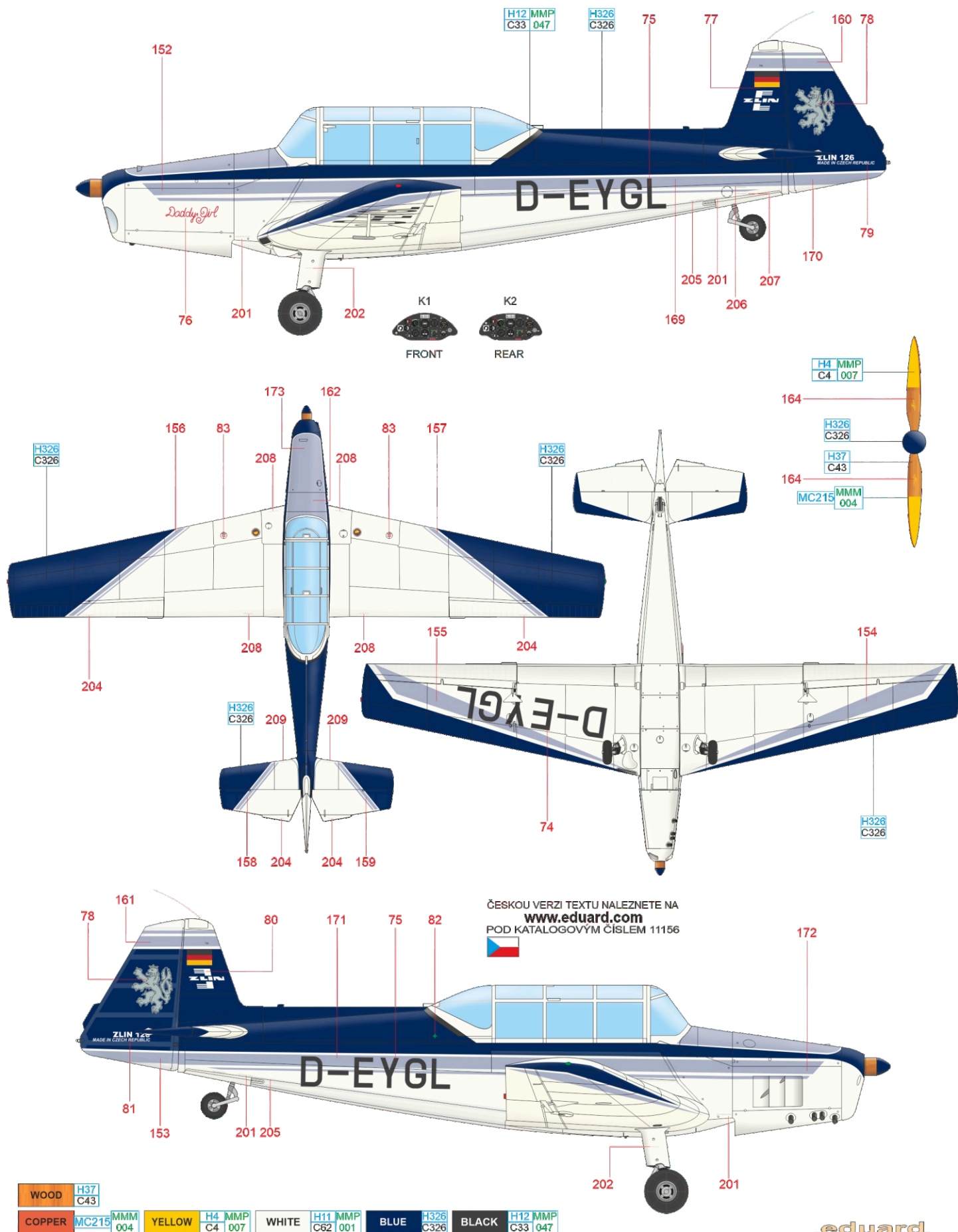

- |        |                     |        |                  |       |                    |      |              |       |                    |
|--------|---------------------|--------|------------------|-------|--------------------|------|--------------|-------|--------------------|
| WOOD   | H37<br>C43          |        |                  |       |                    |      |              |       |                    |
| COPPER | MC215<br>MMM<br>004 | YELLOW | H4 MMP<br>C4 007 | WHITE | H11 MMP<br>C62 001 | BLUE | H326<br>C326 | BLACK | H12 MMP<br>C33 047 |

# E Z-126, OK-IFD, No. 739, Ústí nad Orlicí Aero Club, 1969

OK-IFD was first flown on July 26, 1954 and then headed to AK Liberec, where it was used for pilot training and glider towing. Subsequently it was also used in Ústí nad Labem and Most, from where it was bought by AK Ústí nad Orlicí. However, the aircraft had to be transported by land, as it was at the end of its lifetime period. It was overhauled by the LOTN (Trenčín Aircraft Repairs) and the original military green color was replaced by a more colorful marking. At the same time, a large logo of the then textile factory Perla, which sponsored the overhaul, appeared on the sides of the fuselage under the canopy. Overhauled OK-IFD was test-flown on September 1, 1970, but after Vlastimil Macek emigrated to Austria on a glider in July 1973, the Aero Club had to hand its Trener over. The OK-IFD then travelled through several Aero Clubs, changed colors several times, and finally ended up in Holešov Aero Club in 1982. There is one uncertainty with this marking, as the contemporary witnesses can't decide whether the stripe on the fuselage and wing was blue or black. We provide decal for the blue version; black stripe can be airbrushed instead.

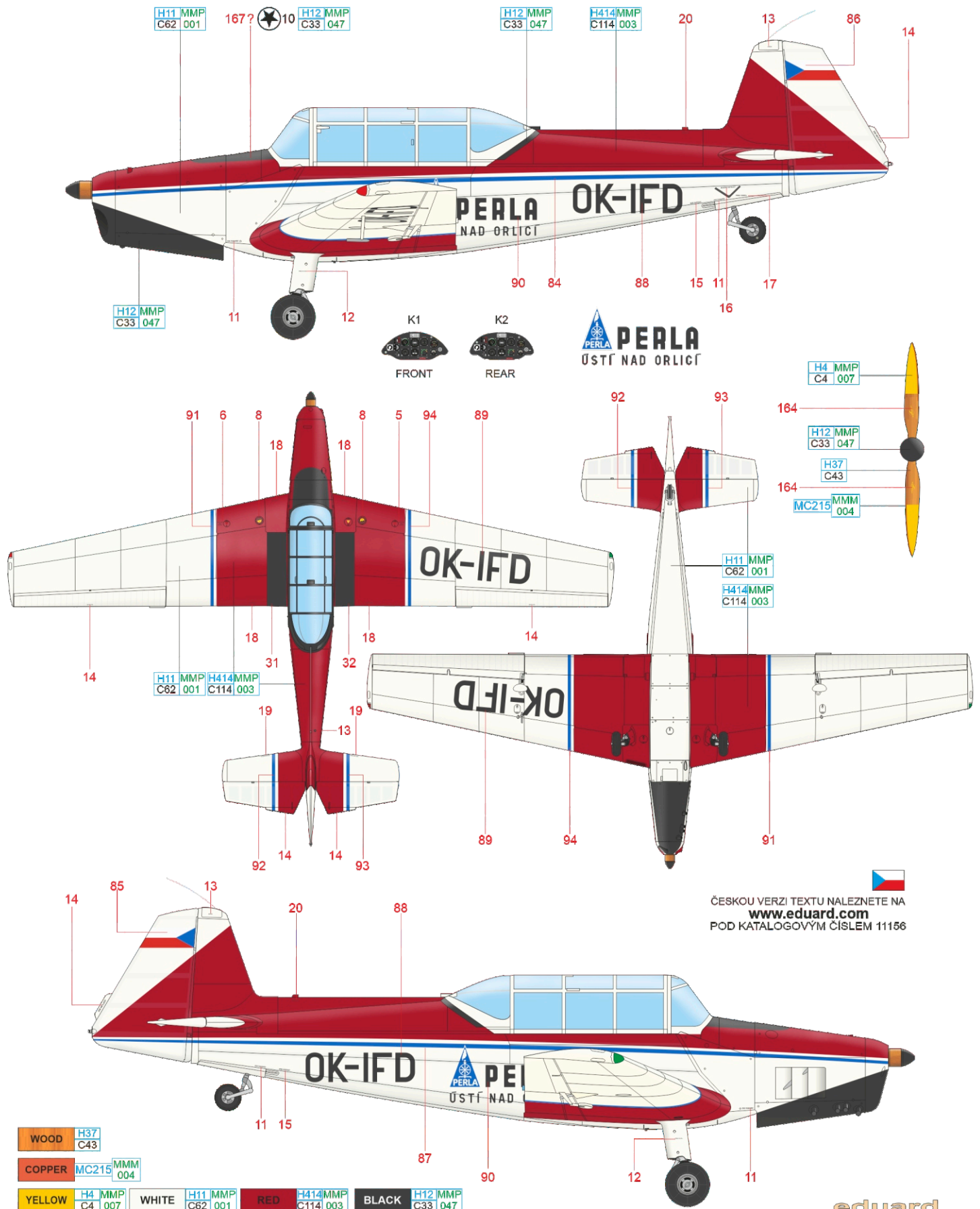

# F Z-126, OK-IHQ, No. 778, private owners, Letňany airfield, 2021

This Z-126 was handed over to Ministry of Defence on February 21, 1955 as a C 105-243. On September 12, 1959, it was entered to the civil register under the OK-IHQ matriculation and put into service with the Svazarm Aero Clubs in Hořice, Plasy and Jičín. The latter used it until 1999. Later it was bought by private owners and the aircraft was given the livery of a 1950s military trainer as a part of an overhaul. Interestingly, the dashboards are painted red, and the aircraft has impressive radio equipment. OK-IHQ is based at the Letňany airfield nowadays.

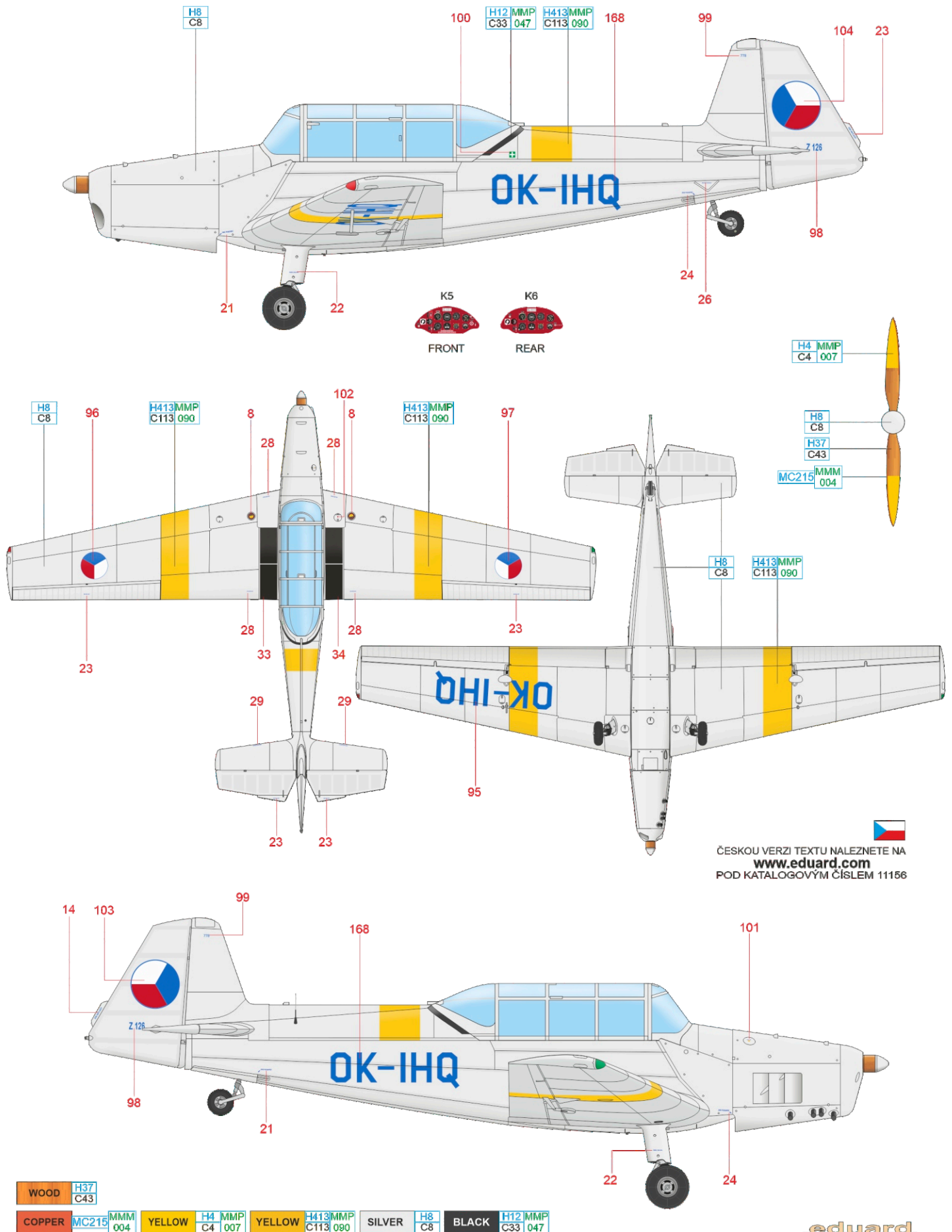

ČESKOU VERZI TEXTU NALEZNETE NA  
[www.eduard.com](http://www.eduard.com)  
 POD KATALOGOVÝM ČÍSLEM 11156

- WOOD H37  
C43
- COPPER MC215  
MMM  
004 YELLOW H4 MMP  
C4 007 YELLOW H413 MMP  
C113 090 SILVER H8  
C8 BLACK H12 MMP  
C33 047

# G Z-126, OK-IVA, No. 737, private owner, Slaný airfield, 2021

This aircraft was produced in 1954 and received the OK-IFB matriculation. It served with the Košice Aero Club from May 15, 1954 and subsequently was used at Nitra airfield as a training aircraft for students of the College of Transportation in Žilina. After that, it was used by the Holíč Aeroclub. In 1992 the aircraft was at the end of its technical lifespan and transferred to Slušovice, where it was stored. Subsequently it was moved to Kunovice. Since 1998 it is in private hands. During 1999 – 2000 period it underwent a major overhaul at ZLIN-AVION Service and after that it was sold and operated again at the Kunovice airfield. In 2017, it changed hands again and is operated from Slaný airfield today, where it is stored in the hangar of the Točná Aero Club. The aircraft has a non-standard flash beacon on the top of the vertical fin.

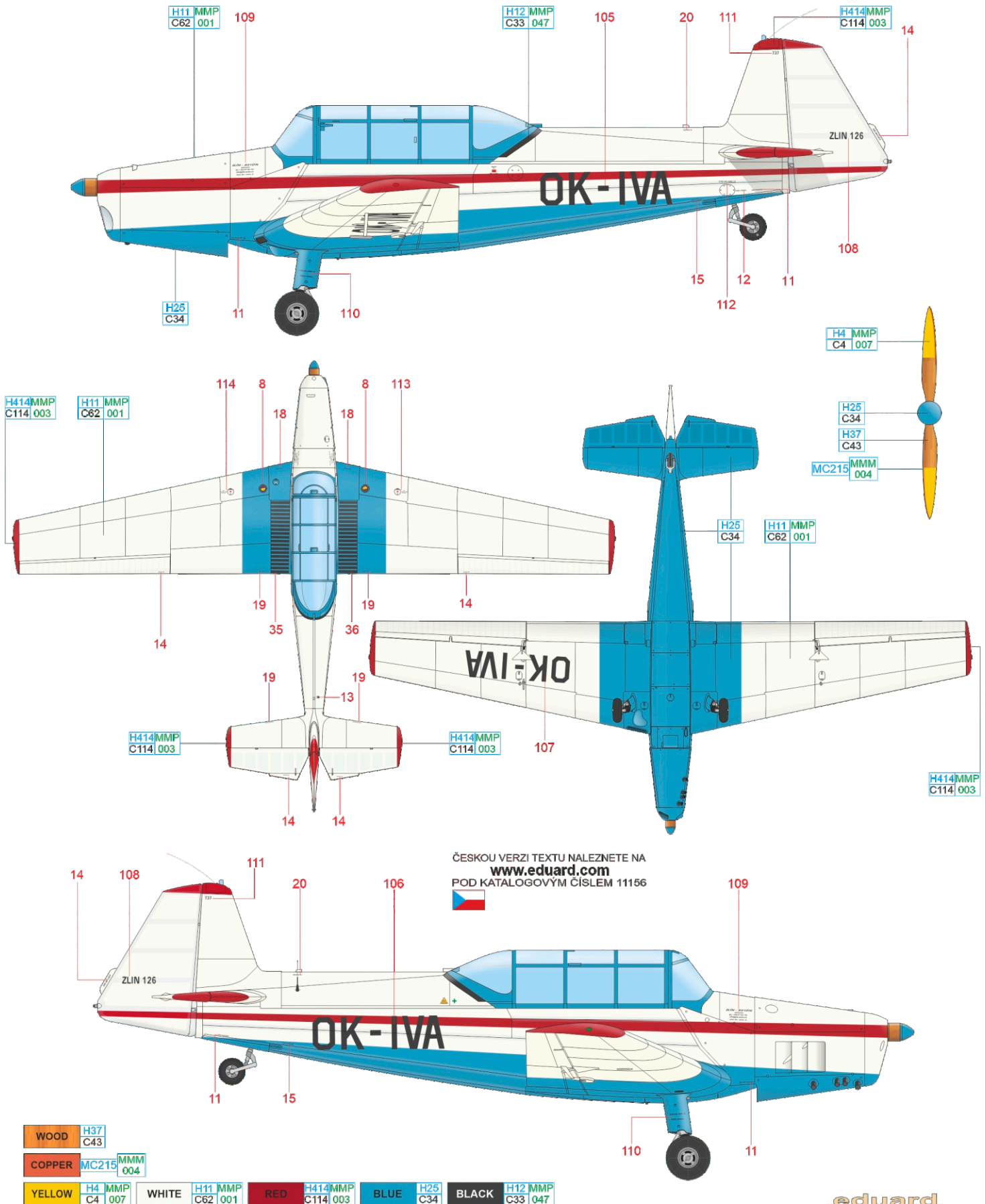

# H Z-126, OK-HLK, No. 722, Kunovice Aero Club, 1970

This Trener served with the army from February 5, 1954, when the Ministry of Defence took it over and used it as C 105-220. Later it was transferred to Uherské Hradiště and flew in Kunovice Aero Club, where in 1969 the powered flying was re-established. After reaching its technical life limit, it was stored in the depository of the Technical Museum Brno and handed over to the Brno company Šperlík later. Thanks to the company's efforts, it was overhauled in Aerotechnik Kunovice. In August 2007, the aircraft had a severe crash in Vysoké Mýto. However, but it was repaired again and is still flying today in new elegant white and blue coloring. Attractive period coloring corresponds to the habits of the Kunovice Aero Club at that time, including the drawing of a "flying witch" on the nose.

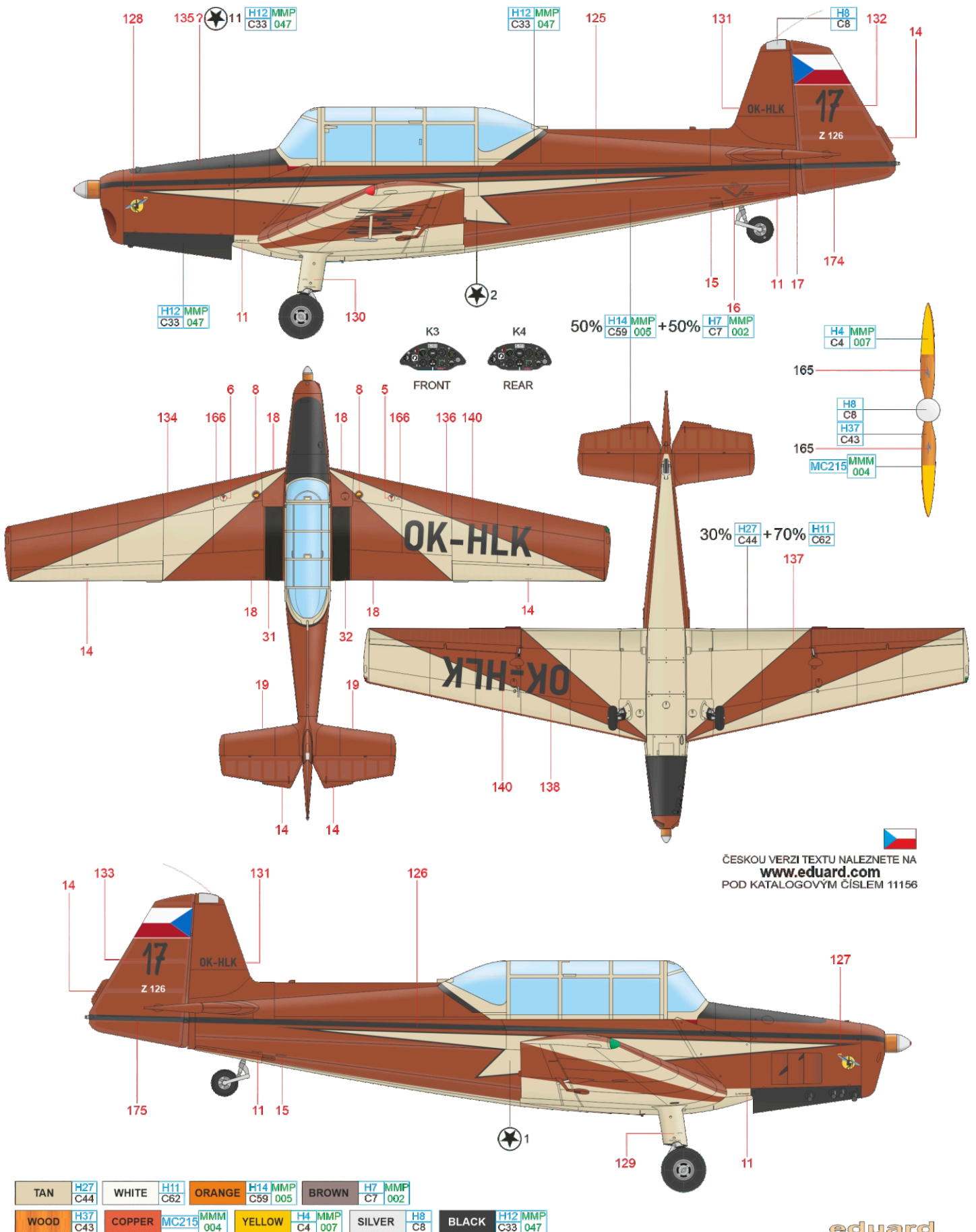

ČESKOU VERZI TEXTU NALEZNETE NA  
[www.eduard.com](http://www.eduard.com)  
 POD KATALOGOVÝM ČÍSLEM 11156

|      |            |        |                  |        |                    |                    |                  |
|------|------------|--------|------------------|--------|--------------------|--------------------|------------------|
| TAN  | H27<br>C44 | WHITE  | H11<br>C62       | ORANGE | H14 MMP<br>C59 005 | BROWN              | H7 MMP<br>C7 002 |
| WOOD | H37<br>C43 | COPPER | MC215<br>MMM 004 | YELLOW | H4 MMP<br>C4 007   | SILVER             | H8<br>C8         |
|      |            |        |                  |        | BLACK              | H12 MMP<br>C33 047 |                  |

# Z-126, OK-IHO, No. 705, Brno-Slatina Aero Club, spring 1977

The Z-126 of serial number 705 served with the army as C 105-234 from March 30, 1954. It was entered into the civil register on December 18, 1958 and served with the Brno Aero Club for many years. In the spring of 1977, it had only about five flying hours left in its service life, so the members of the Aero Club decided to "decorate" the aircraft a little. The shark's mouth motif was chosen, but when the then regional chief technician engineer of the Svazarm (Union for civilian cooperation with army) saw the work, he was not impressed and demanded the painting to be removed. However, the situation was saved by the regional chief of Svazarm, Colonel Holubář, who immediately declared that he wanted to fly the painted Trener first. And so, the new design was approved... Finally, this Trener was removed from the register on July 21, 1977.

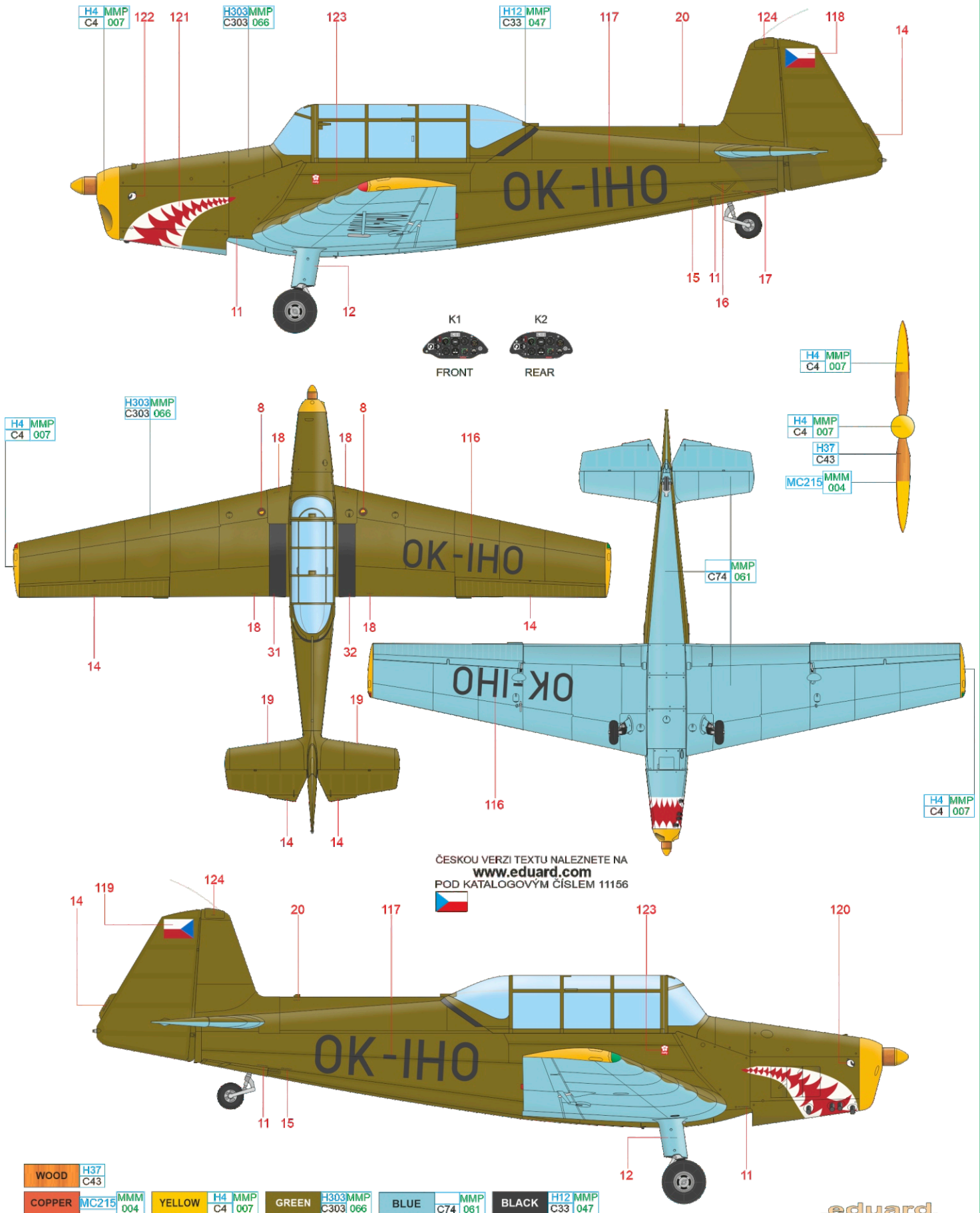

ČESKOU VERZI TEXTU NALEZNETE NA  
[www.eduard.com](http://www.eduard.com)  
 POD KATALOGOVÝM ČÍSLEM 11156

- |        |                  |        |                  |       |                     |      |                |       |                    |
|--------|------------------|--------|------------------|-------|---------------------|------|----------------|-------|--------------------|
| WOOD   | H37<br>C43       | YELLOW | H4 MMP<br>C4 007 | GREEN | H303MMP<br>C303 066 | BLUE | MMP<br>C74 061 | BLACK | H12 MMP<br>C33 047 |
| COPPER | MC215<br>MMM 004 |        |                  |       |                     |      |                |       |                    |

# J Z-126T, OK-MFV, v. no. 168, Aeroklub Kladno, 2020

When the OK-JHA Z-126 Trener ended its service with Kladno Aero Club due to the end of its technical lifespan in November 2013, its engine together with the propeller and engine cowls were transported to ZLIN-AVION Service company in Otrokovice. In the same direction, the Z-226MS airframe of the OK-MFV matriculation headed to mate with OK-JHA's parts to create new Z-126T. As part of this conversion, the newly built aircraft also received the original livery and OK-MFV matriculation. It was test-flown in January 2014 and is still flying with Kladno Aero Club. The "donor" of the engine and of other parts, OK-JHA, was manufactured in 1955 and subsequently stored at the manufacturer's premises before being handed over to the Svazarm on March 1, 1957. It was flown mainly at Točná and Kladno, where it ended its journey.

