

eduard

LIMITED



THE ZIPPER

F-104C Starfighter in Vietnam war

INSTRUCTION SHEET

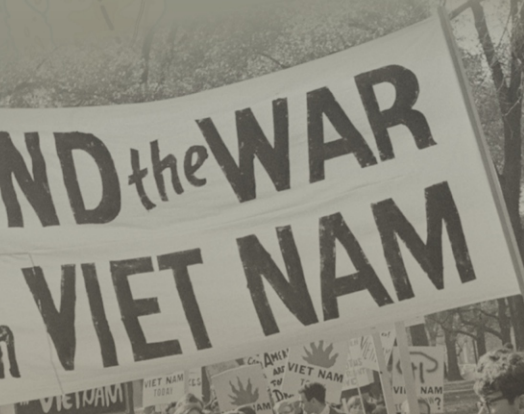

1/48

11169-NAV1

ATTENTION



UPOZORNĚNÍ



ACHTUNG



ATTENTION



注意



Carefully read instruction sheet before assembling. When you use glue or paint, do not use near open flame and use in well ventilated room. Keep out of reach of small children. Children must not be allowed to suck any part, or pull vinyl bag over the head.



Před započatím stavby si pečlivě prostudujte stavební návod. Při používání barev a lepidel pracujte v dobře větrané místnosti. Lepidla ani barvy nepoužívejte v blízkosti otevřeného ohně. Model není určen malým dětem, mohlo by dojít k požití drobných dílů.

INSTRUCTION SIGNS * INSTR. SYMBOLS * INSTRUKTION SINNBILDEN * SYMBOLES * 記号の説明

OPTIONAL
VOLBABEND
OHNOUTSAND
BROUSITOPEN HOLE
VYVRTAT OTVORSYMETRICAL ASSEMBLY
SYMETRICKÁ MONTÁŽREMOVE
ODŘÍZNOUTREVERSE SIDE
OTOČITAPPLY EDUARD MASK
AND PAINT
POUŽIT EDUARD MASK
NABARVITPLEASE CHECK THE LATEST VERSION OF THE INSTRUCTIONS ON www.eduard.com

PARTS



DÍLY



TEILE



PIÈCES



部品

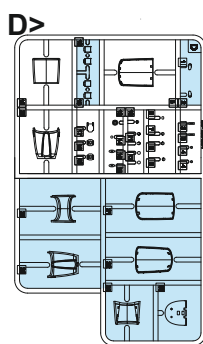
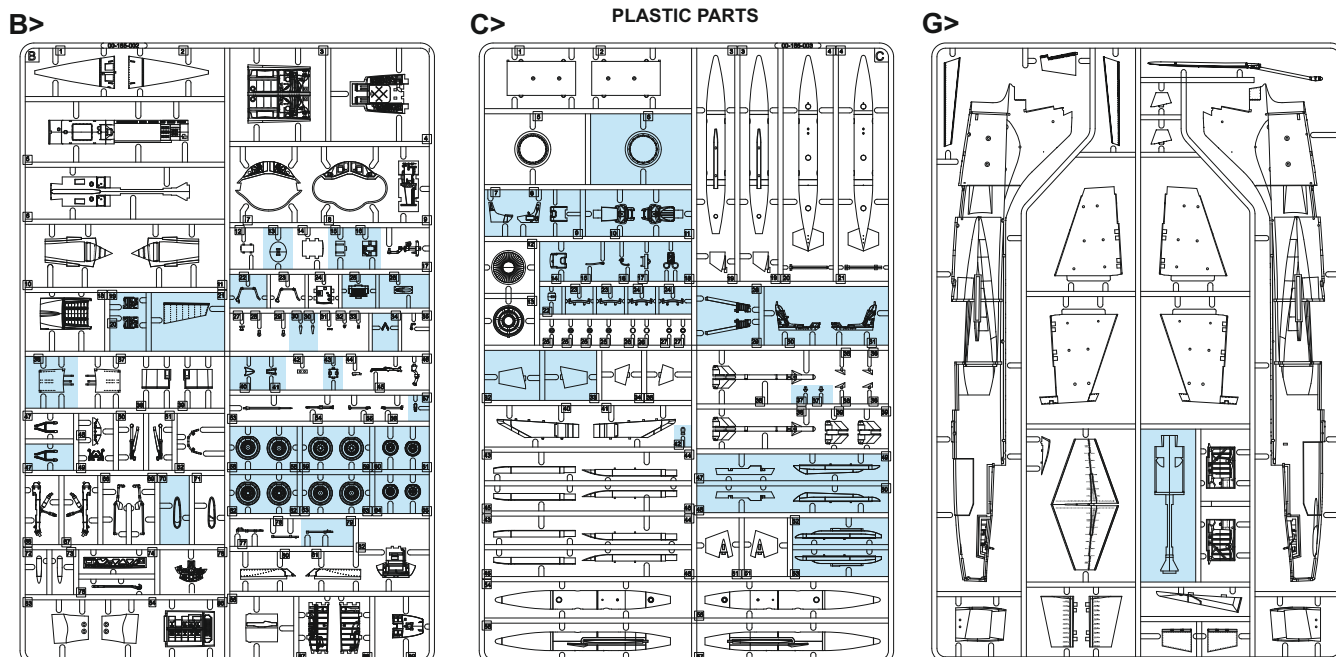

PE - PHOTO ETCHED DETAIL PARTS

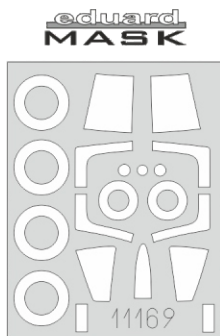
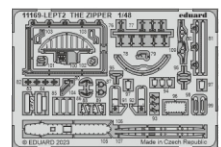
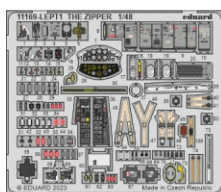

RP - RESIN PARTS

R1
2pcs.

R2



R3



R12



R13



R14



R4



R7

R15

-Parts not for use. -Teile werden nicht verwendet. -Pièces à ne pas utiliser. -Tyto díly nepoužívejte při stavbě. - 使用しない部品

COLOURS



BARVY



FARBEN



PEINTURE



色

GSI Creos (GUNZE)		
AQUEOUS	Mr.COLOR	
[H1]	C1	WHITE
[H8]	C8	SILVER
[H11]	C62	FLAT WHITE
[H12]	C33	FLAT BLACK
[H25]	C34	SKY BLUE
[H27]	C44	TAN
[H57]	C73	AIRCRAFT GRAY
[H77]	C137	TIRE BLACK
[H80]	C54	KHAKI GREEN
[H90]	C47	CLEAR RED
[H94]	C138	CLEAR GREEN
[H303]	C303	GREEN
[H304]	C304	OLIVE DRAB

GSI Creos (GUNZE)		
AQUEOUS	Mr.COLOR	
[H309]	C309	GREEN
[H310]	C310	BROWN
[H311]	C311	GRAY
[H316]	C316	WHITE
[H317]	C317	GRAY
[H327]	C327	RED
[H328]	C328	BLUE
Mr.METAL COLOR		
[MC213]		STEEL
[MC214]		DARK IRON
Mr.COLOR SUPER METALLIC		
[SM201]		SUPER FINE SILVER
[SM204]		SUPER STAINLESS 2

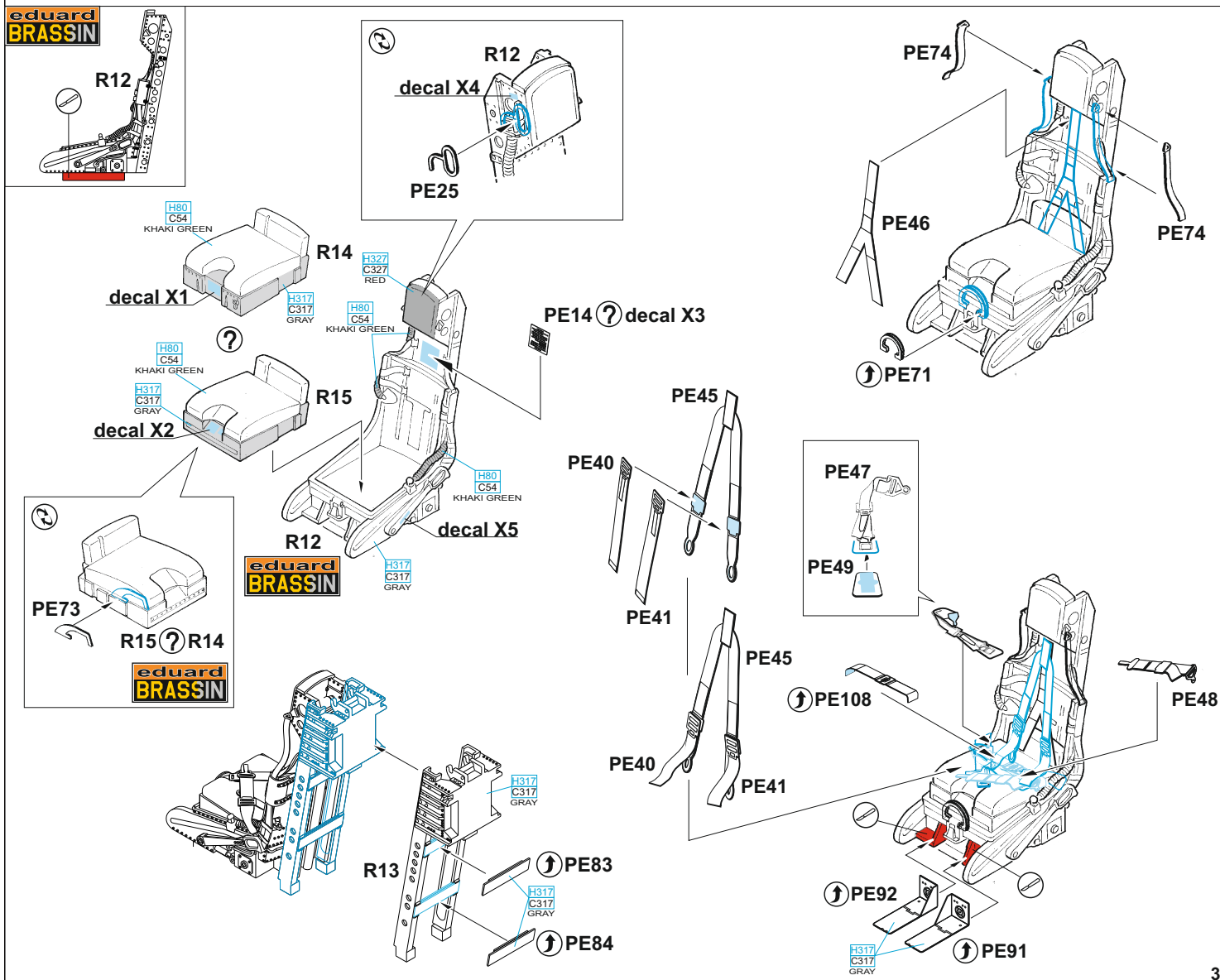
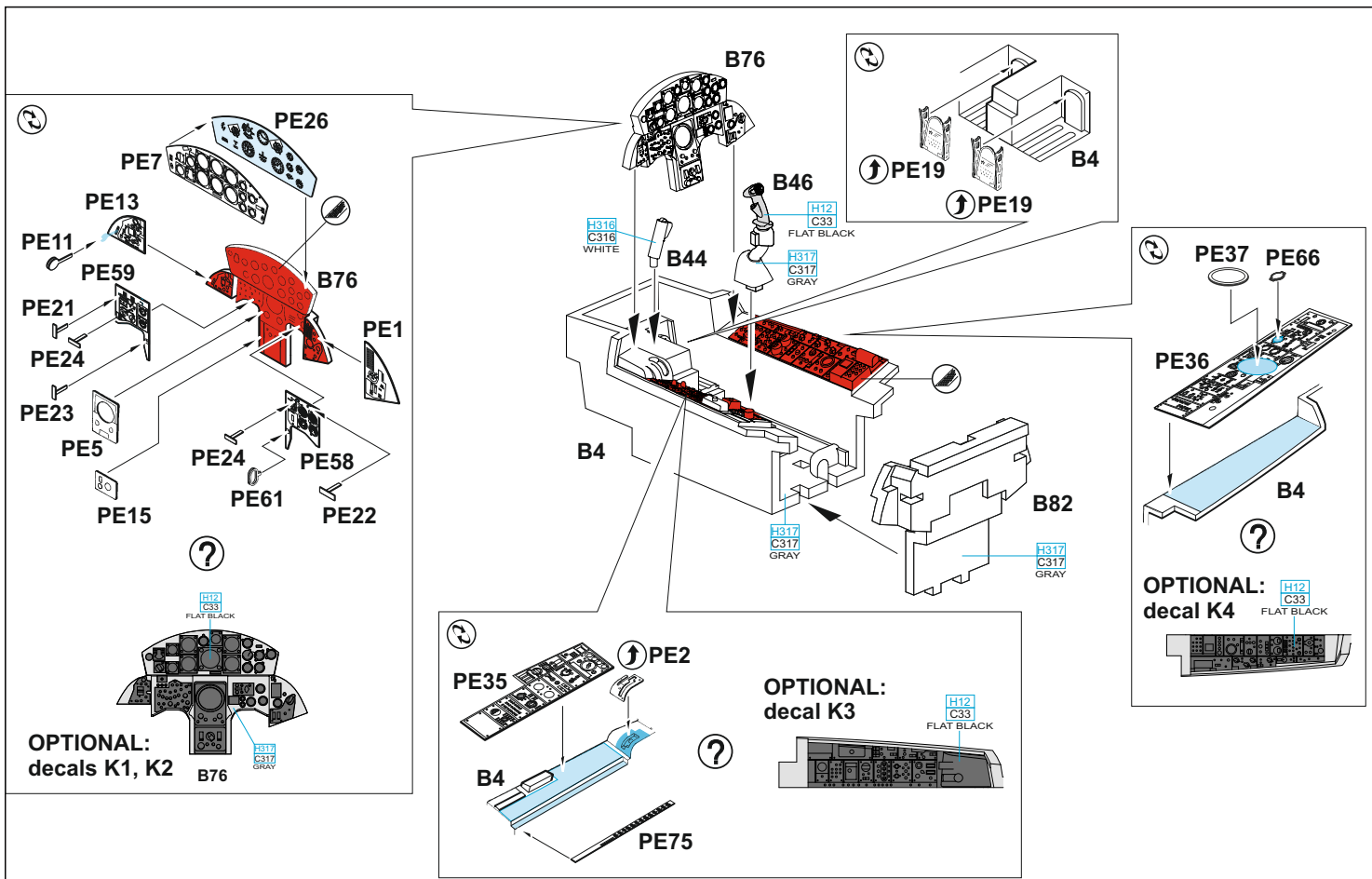

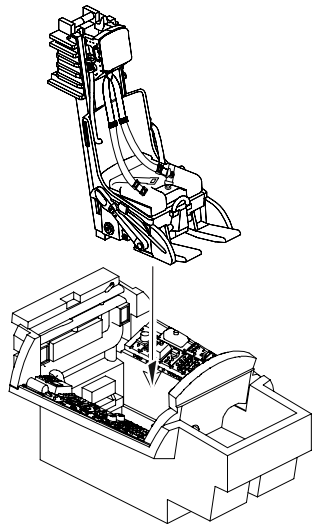

B

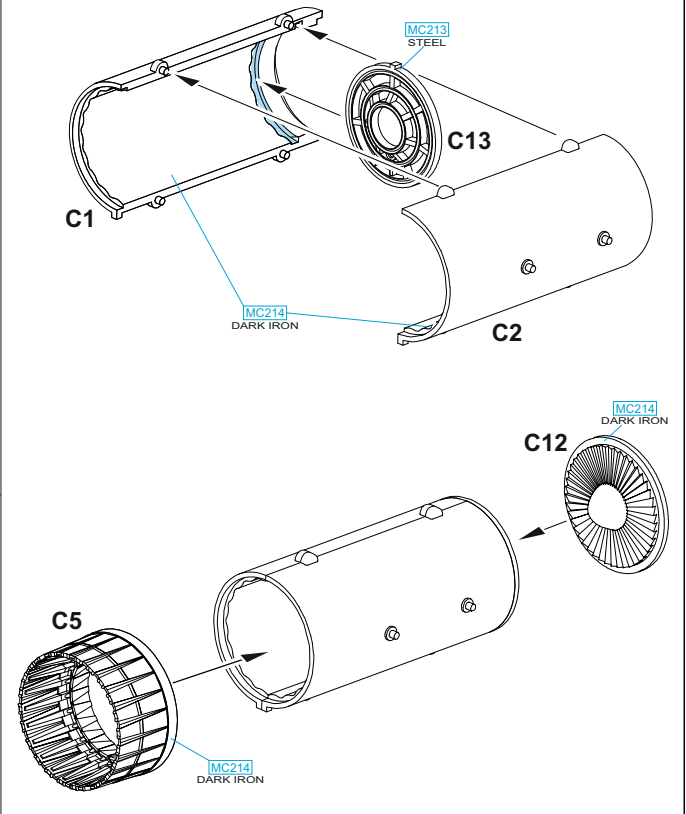

C

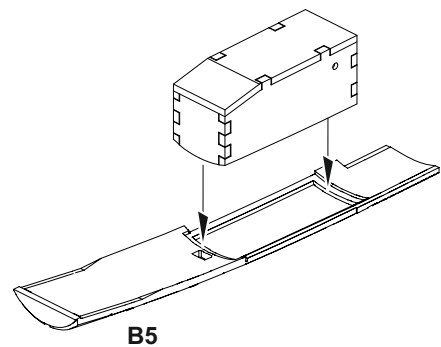
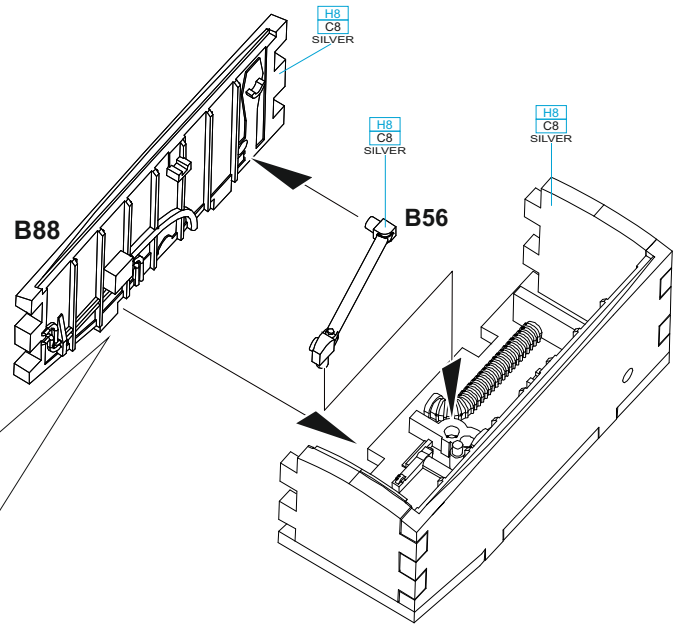
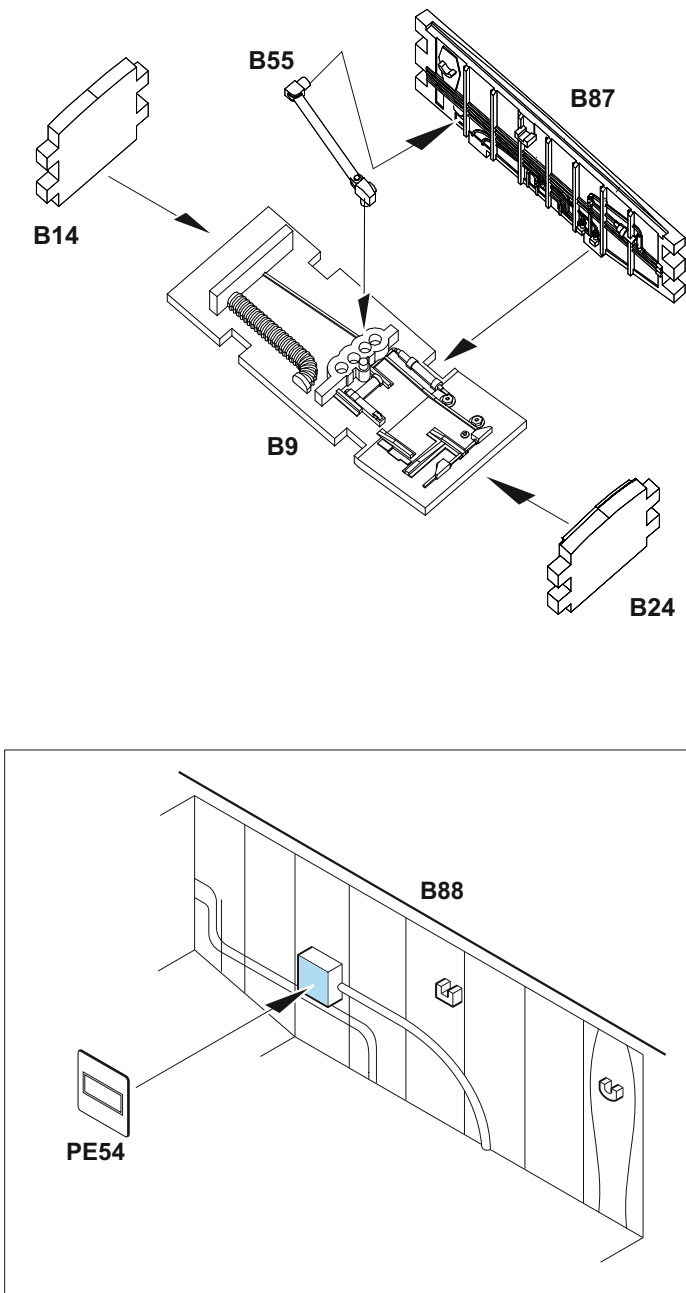

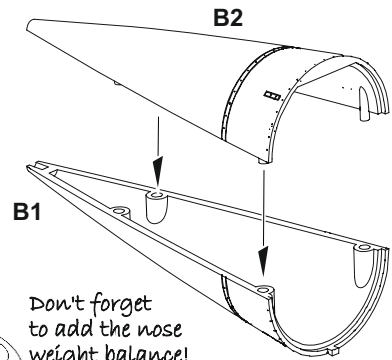
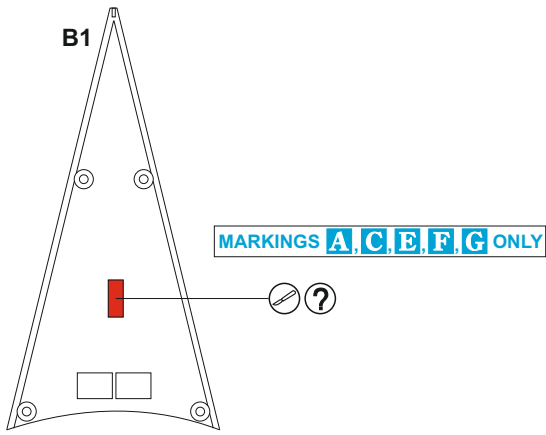

Don't forget
to add the nose
weight balance!

D

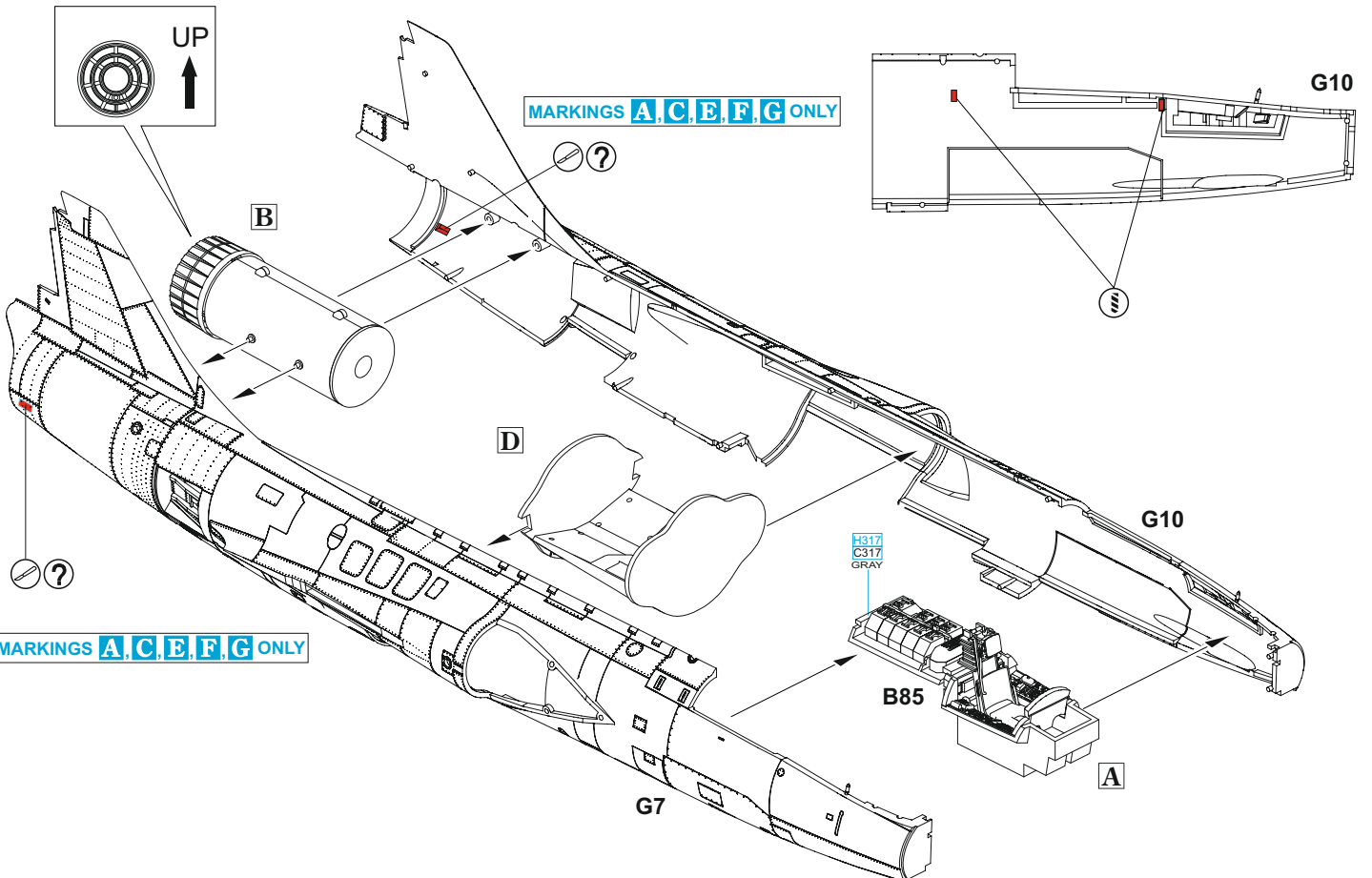
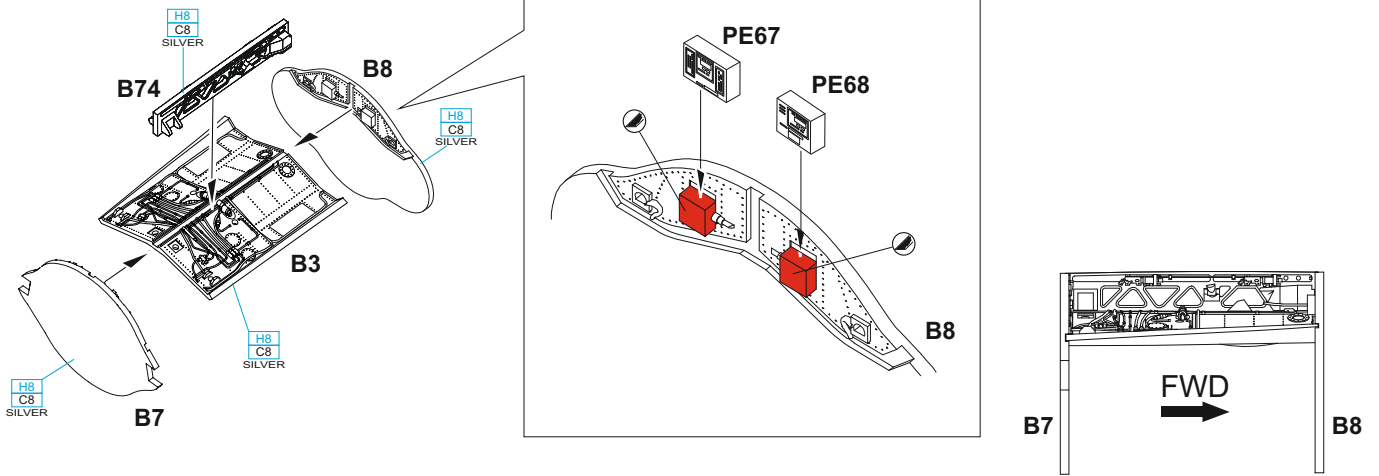

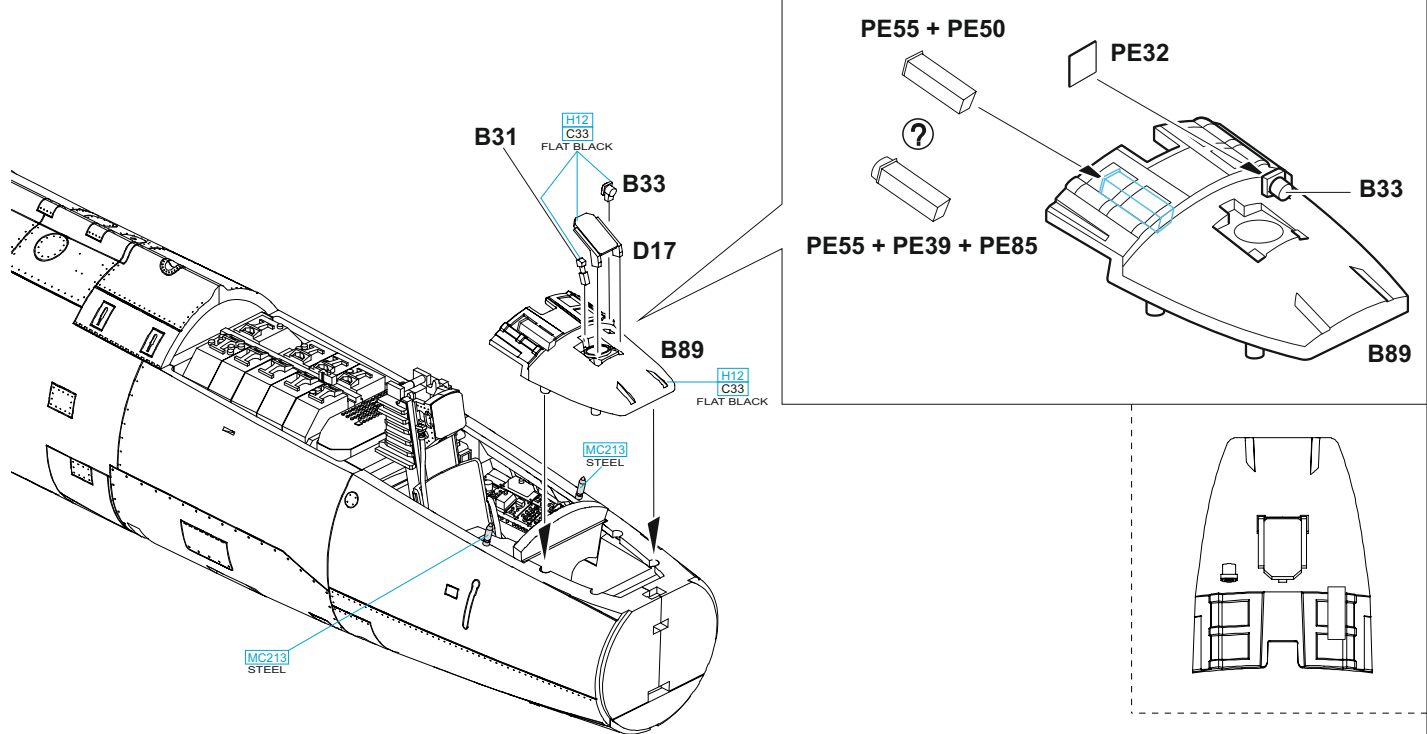
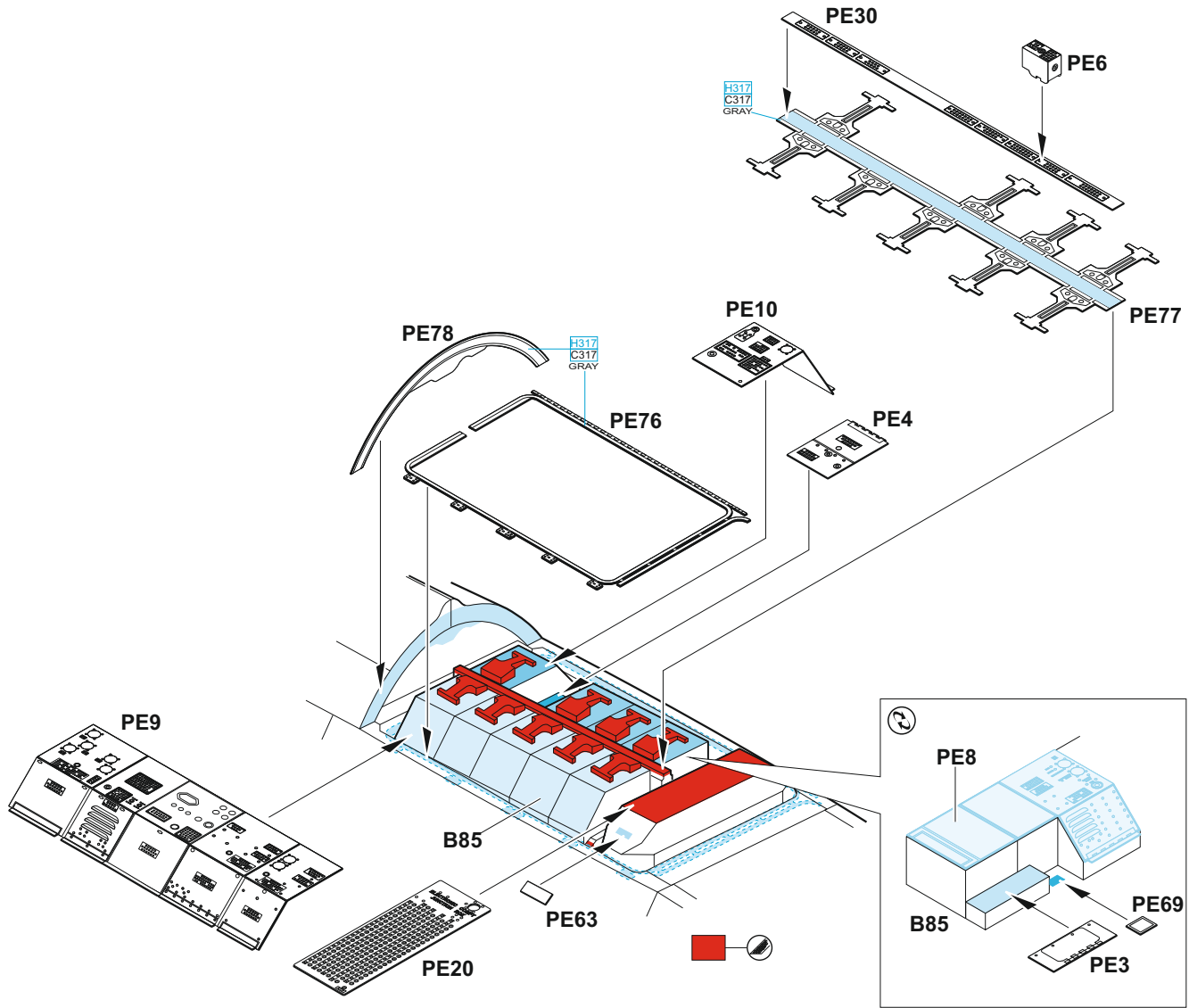

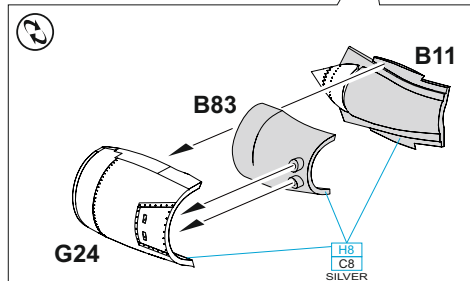
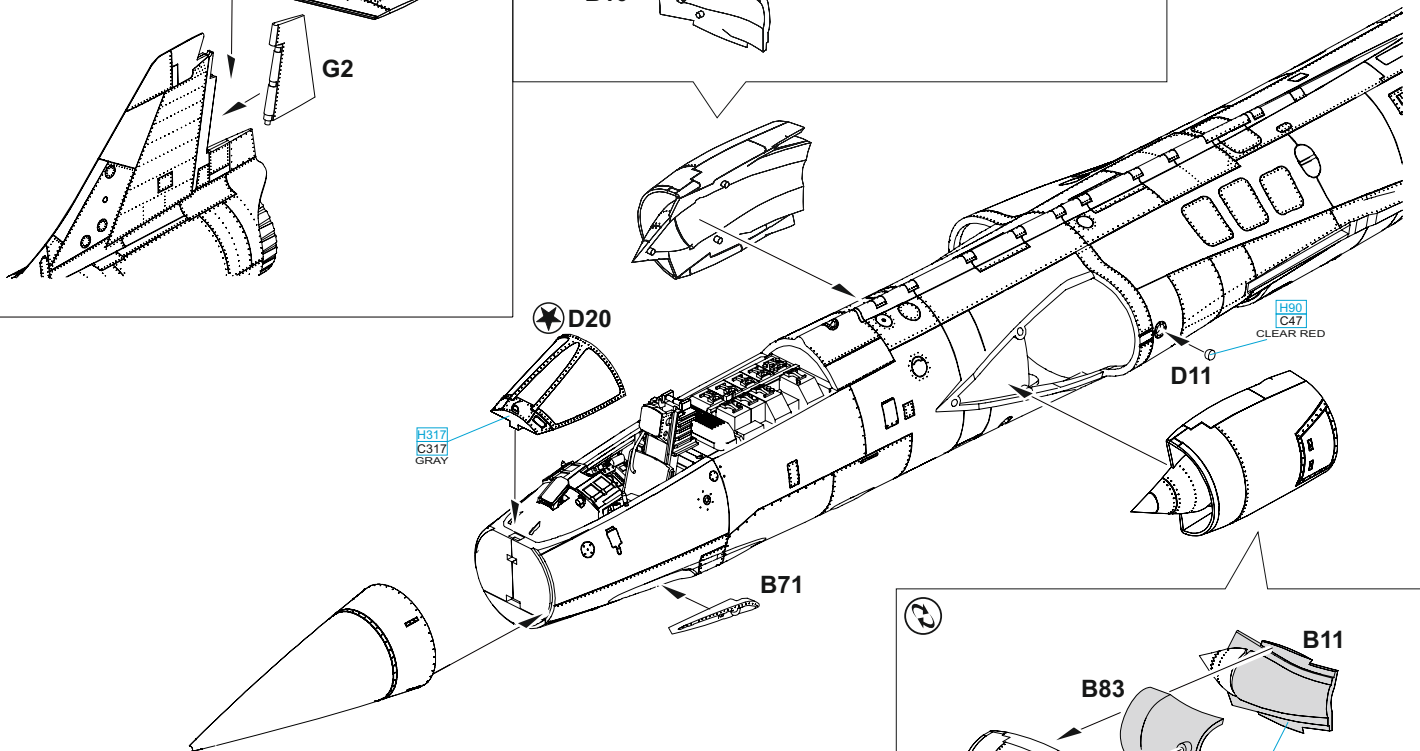
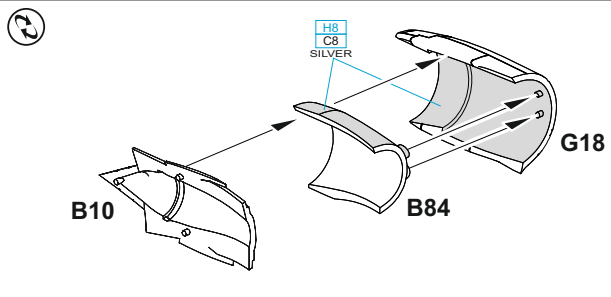
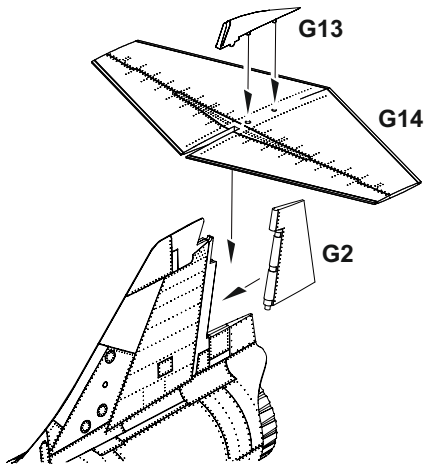
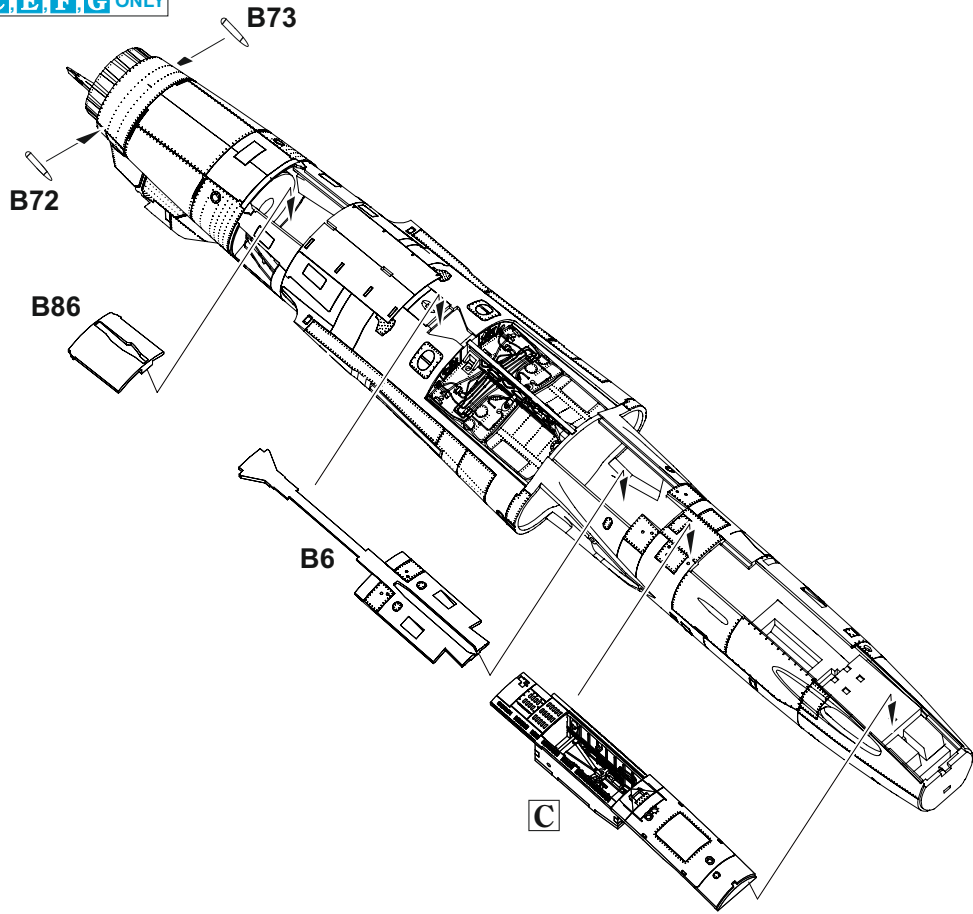

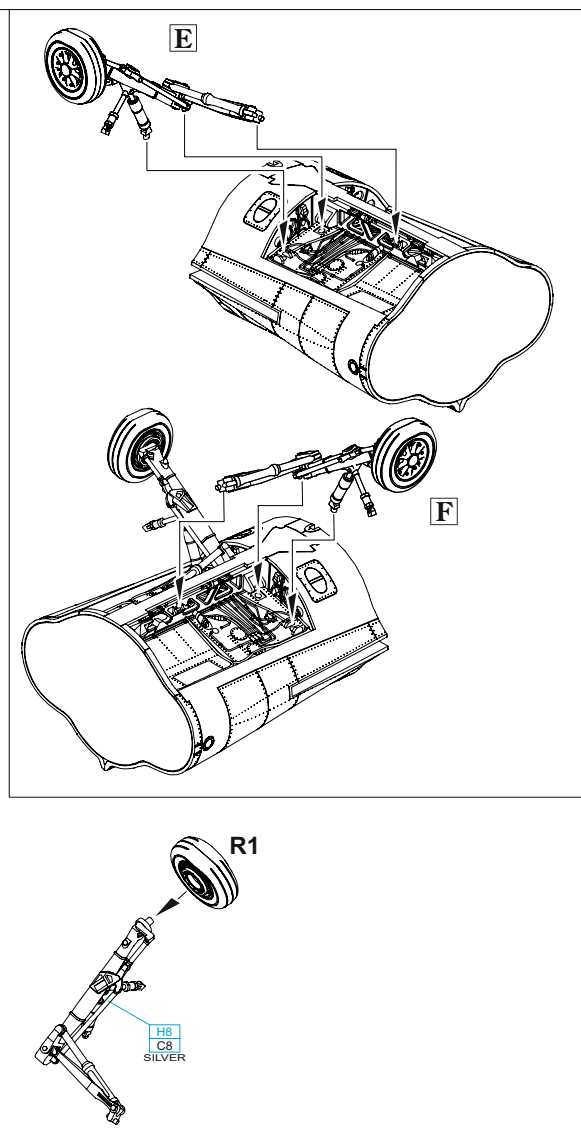
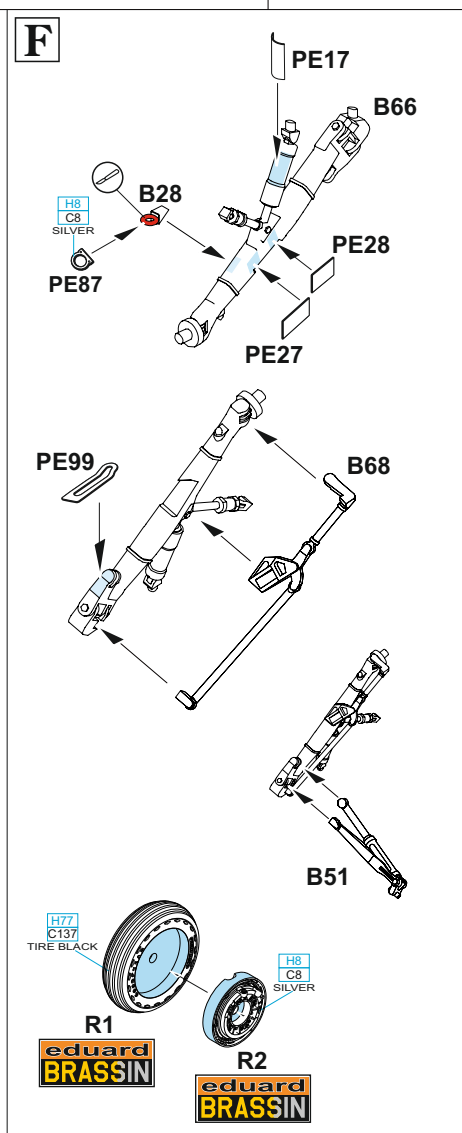
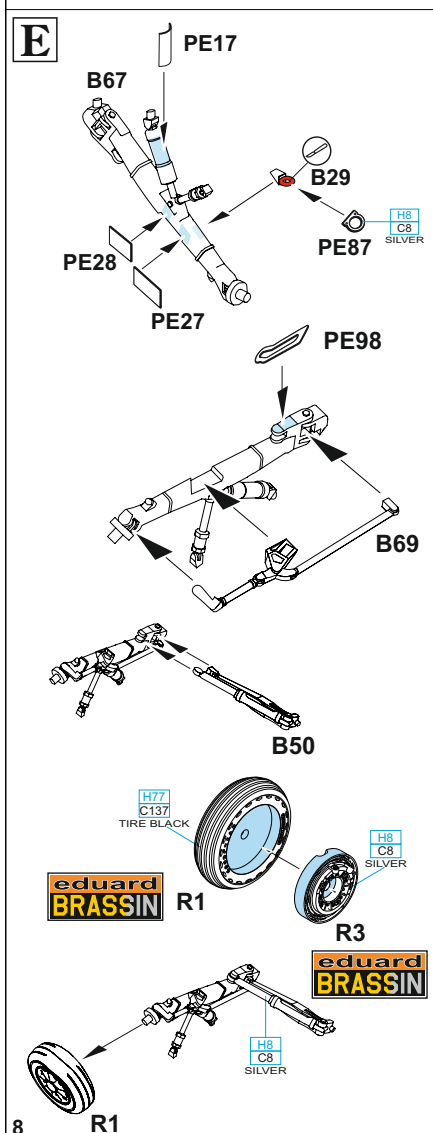
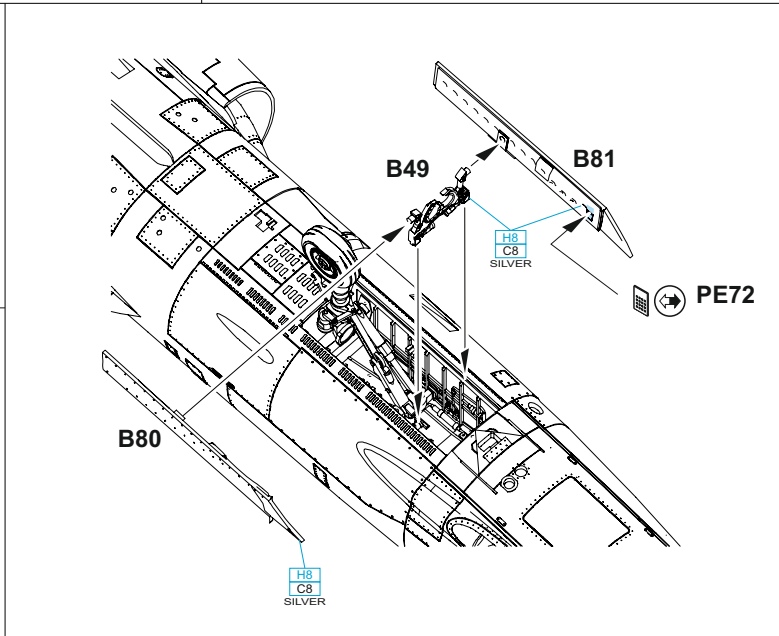
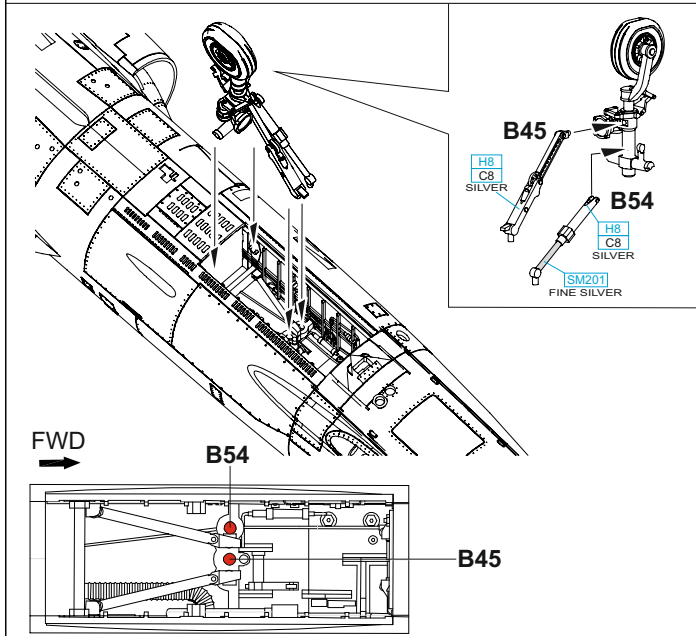
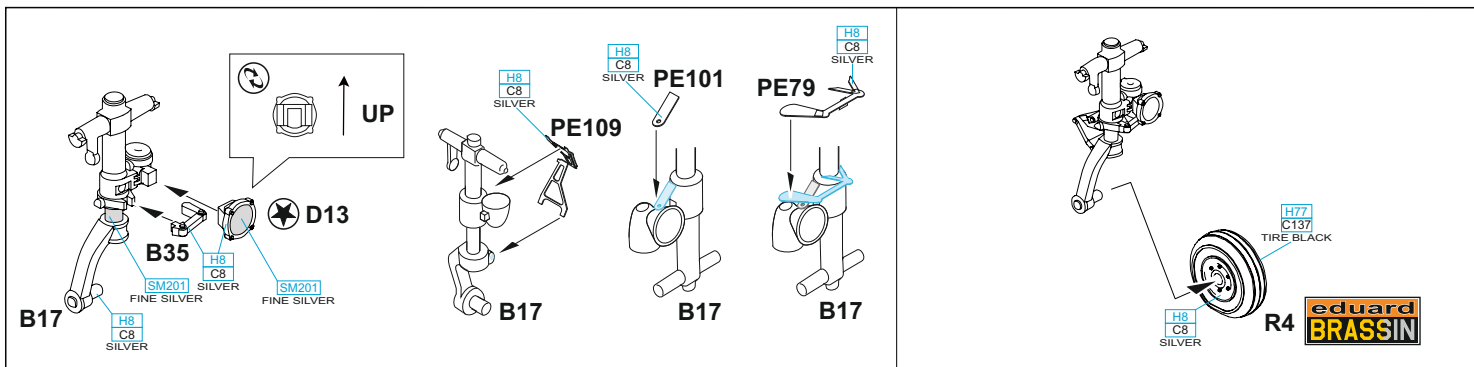

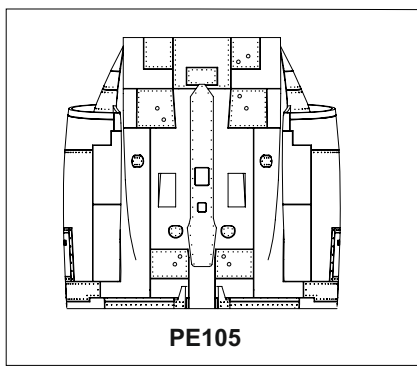
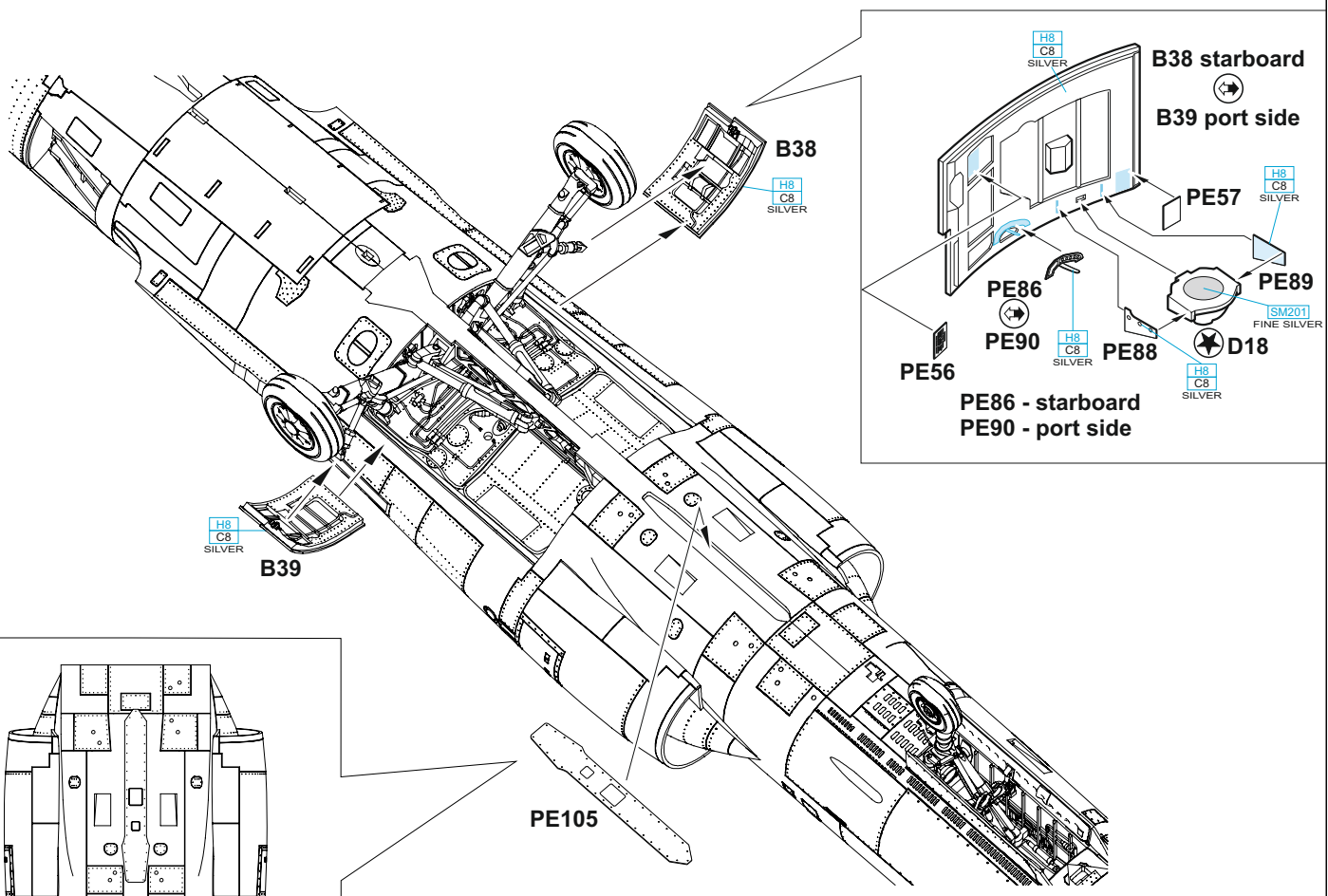

PE105

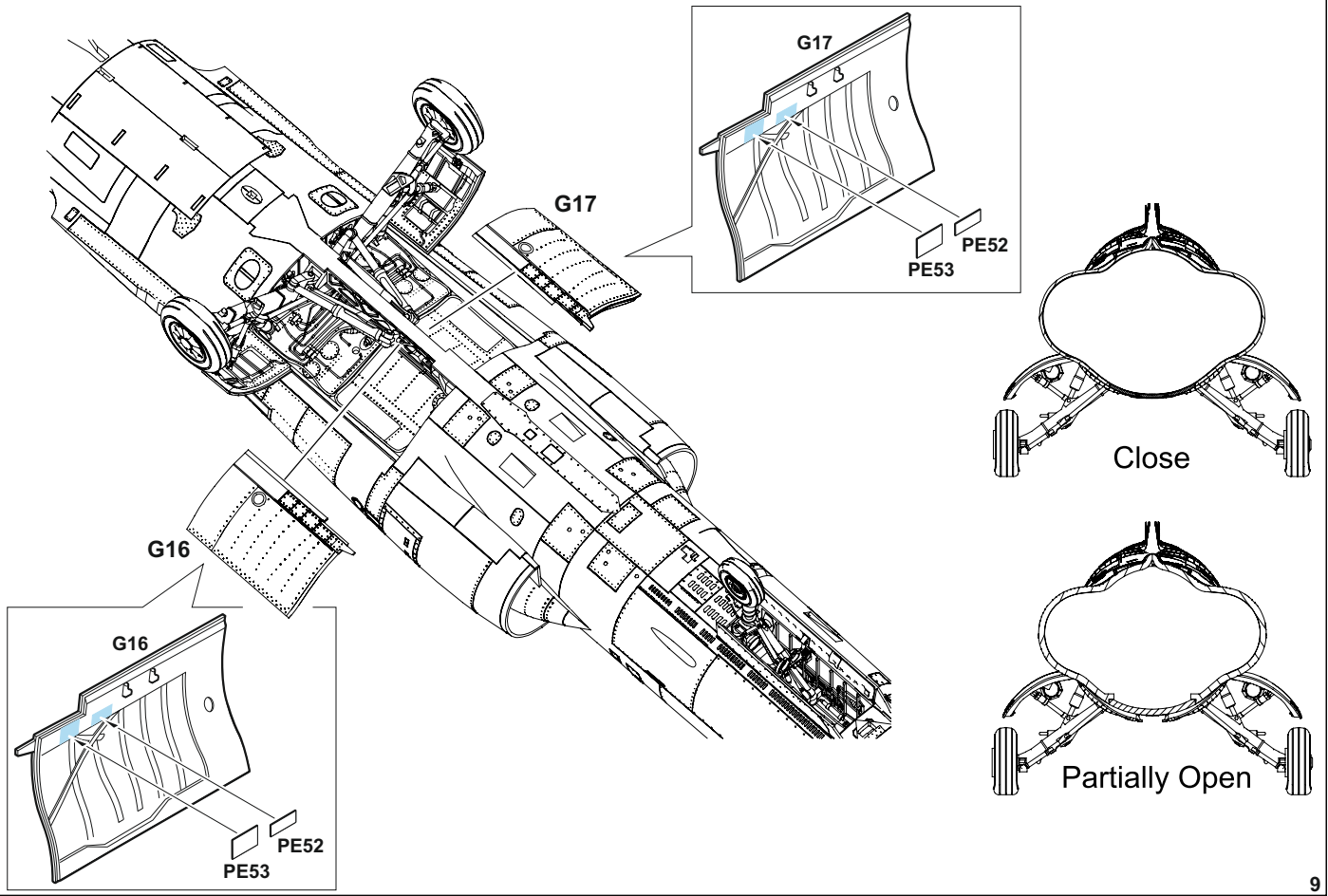

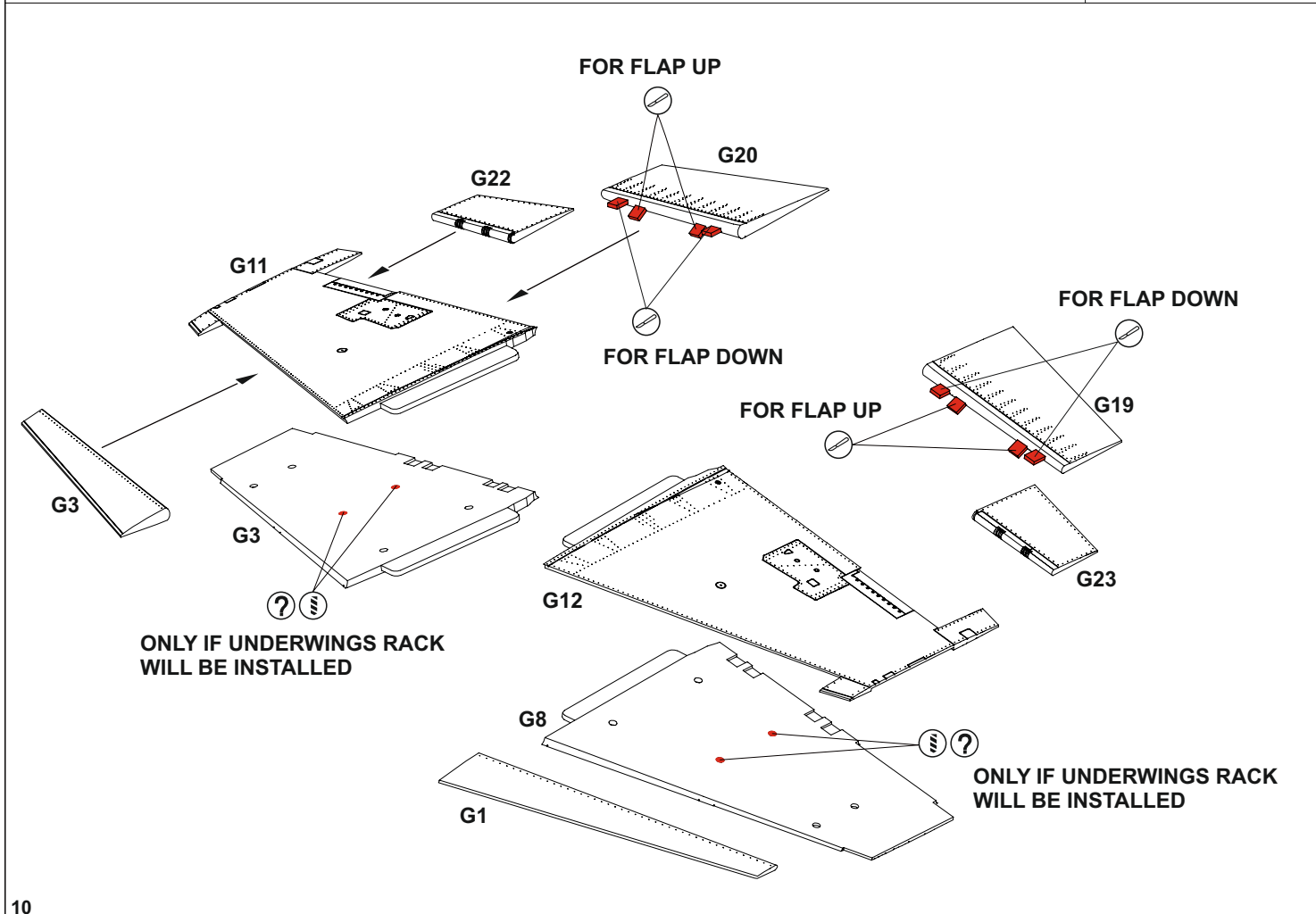
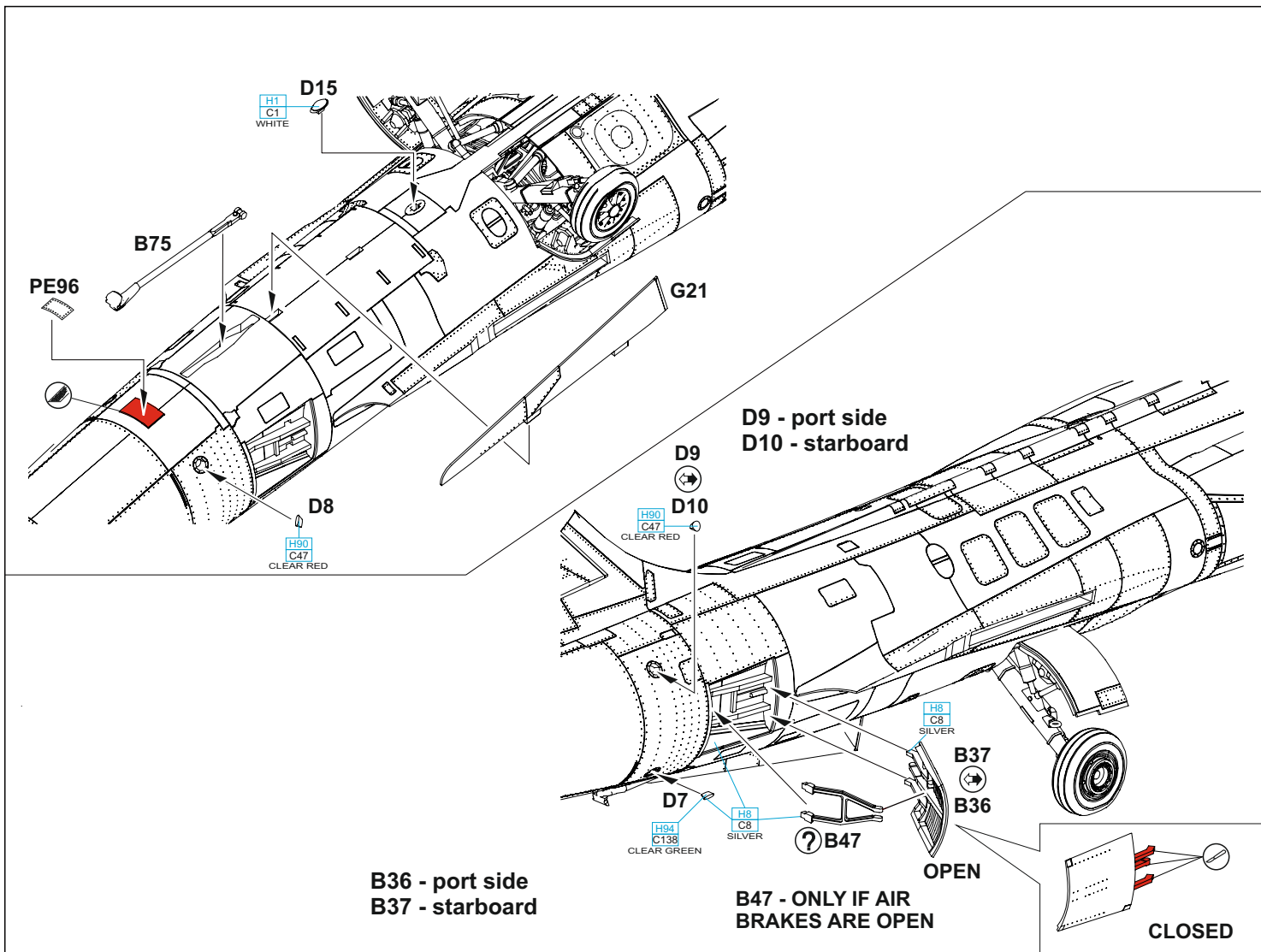

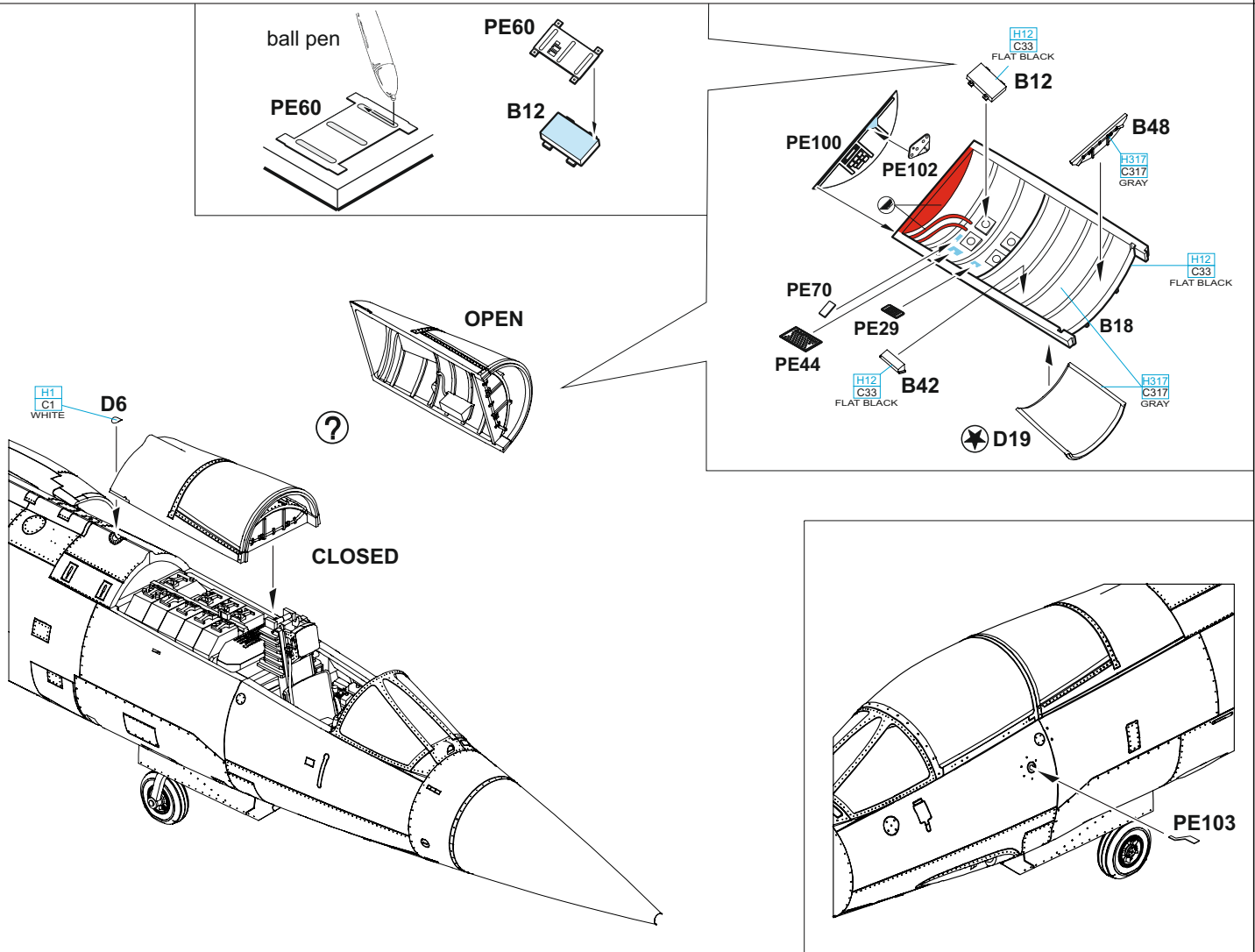
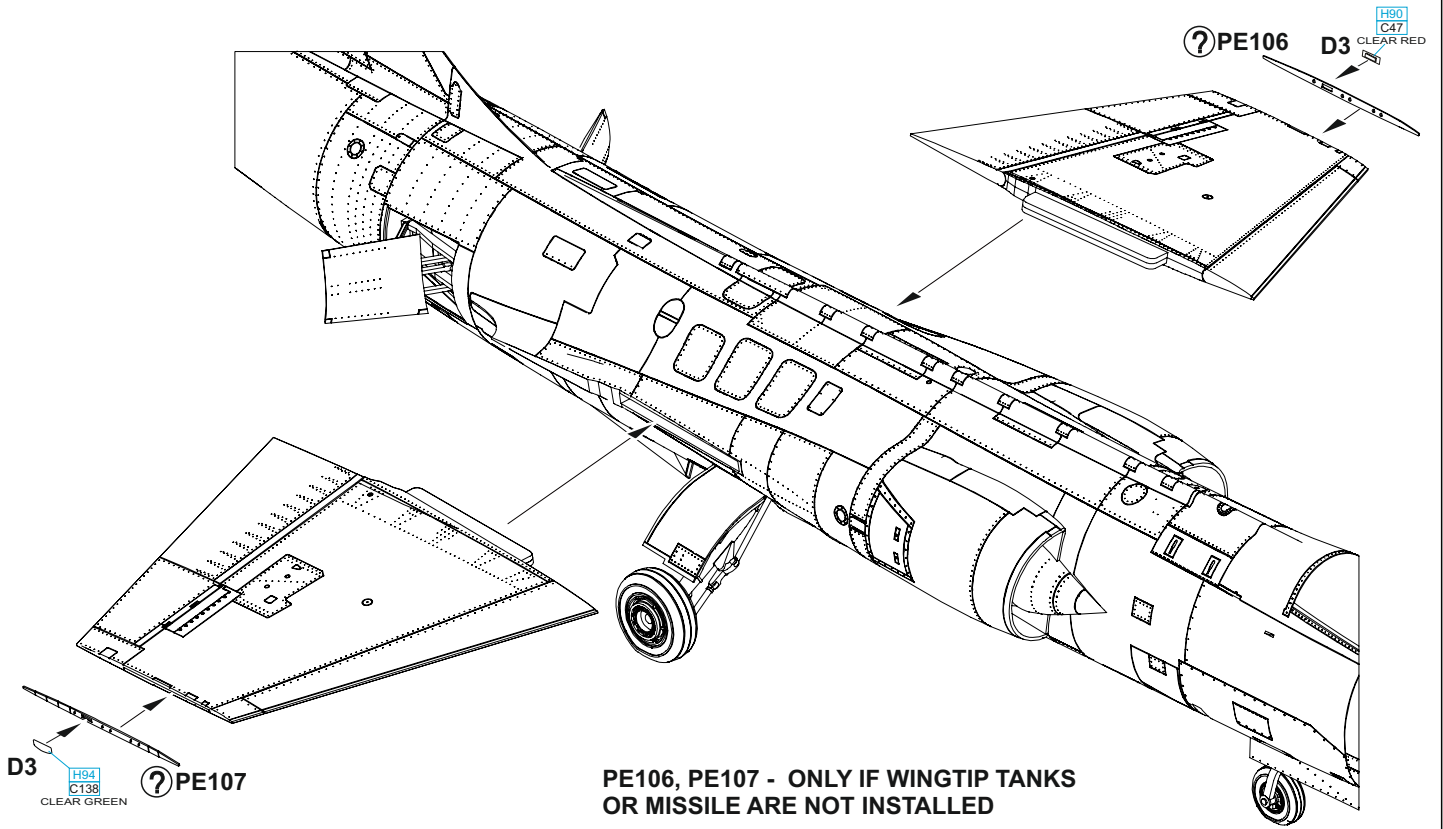

PE12, PE38, PE39 - INSTALL ONLY IF CANOPY IS OPEN

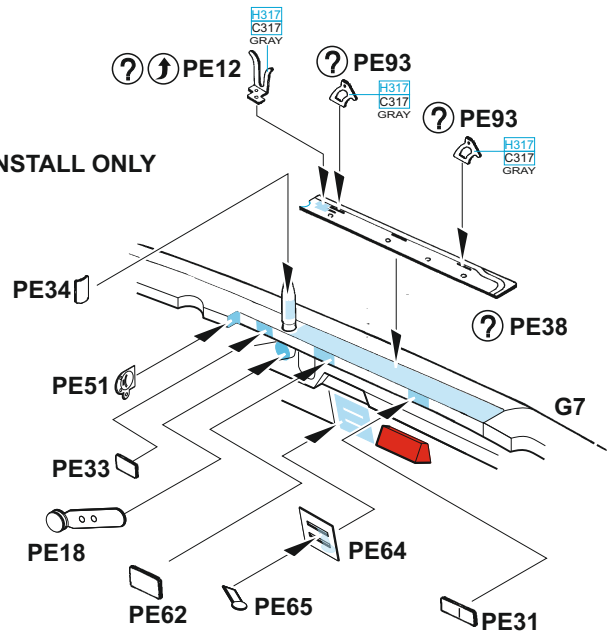
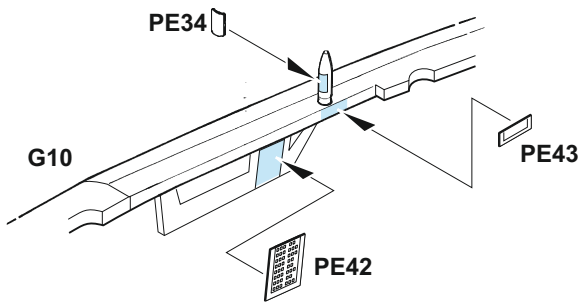

G

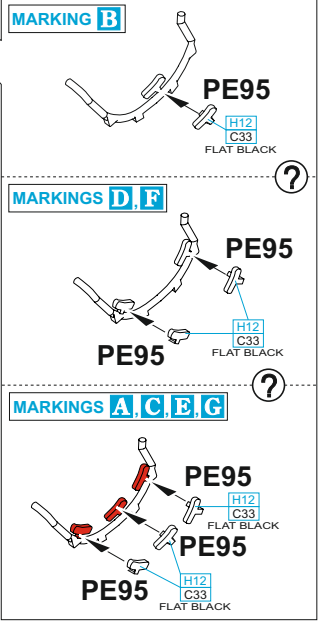
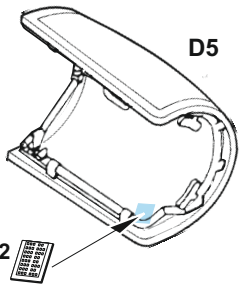
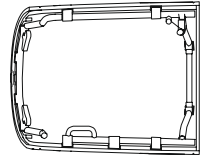
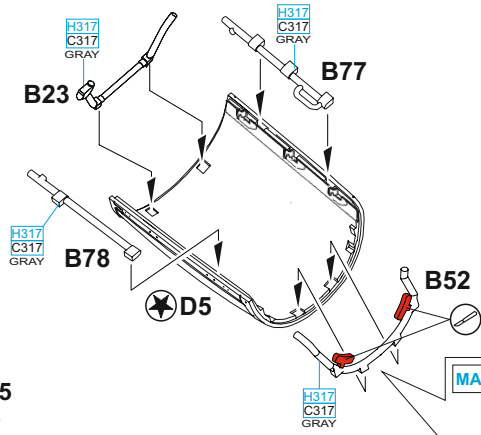
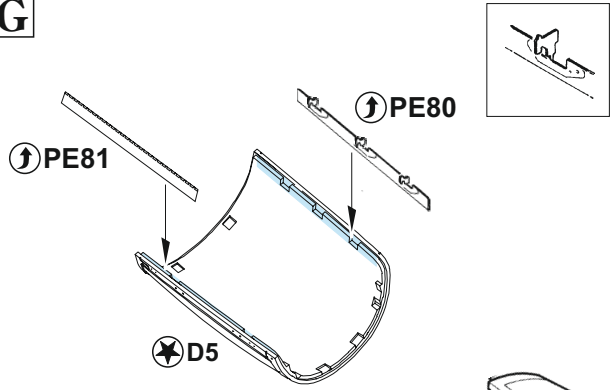

G

CLOSED CANOPY

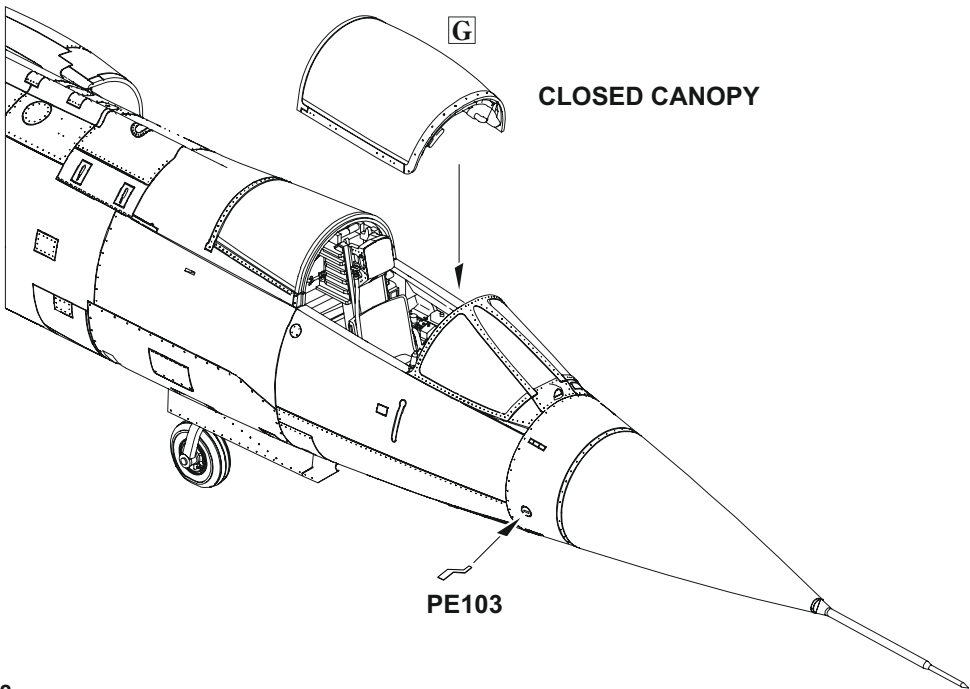

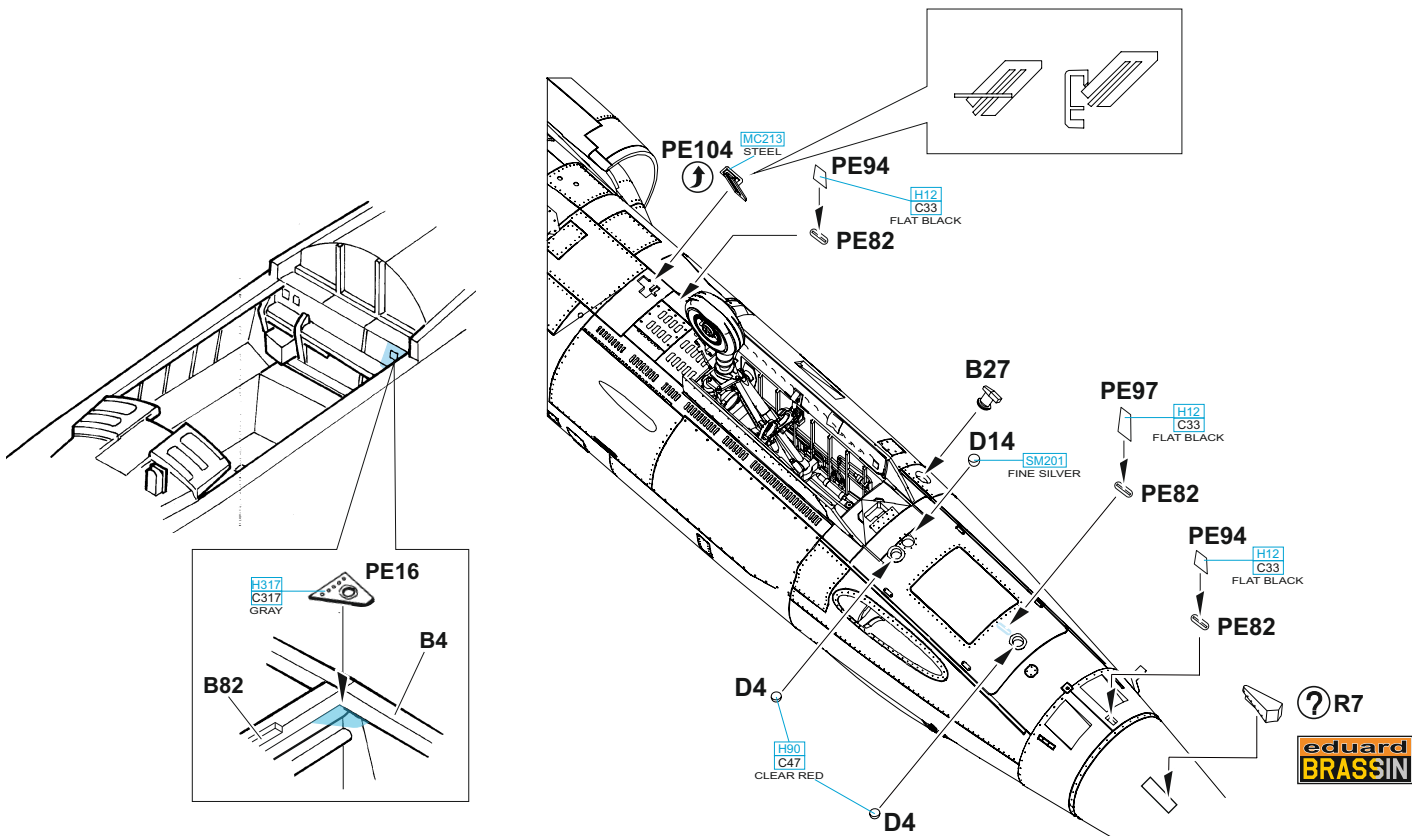
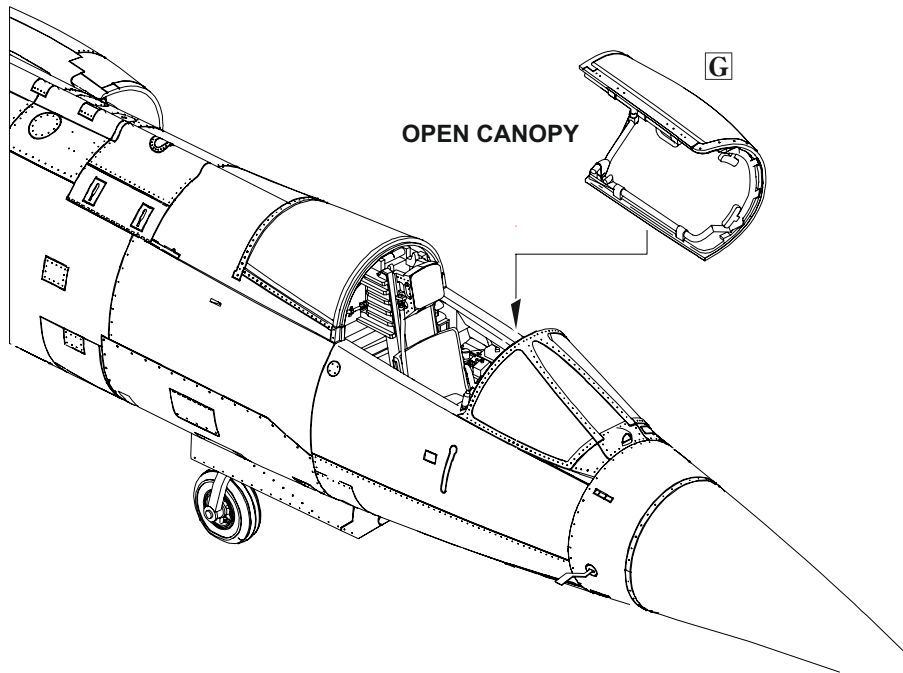
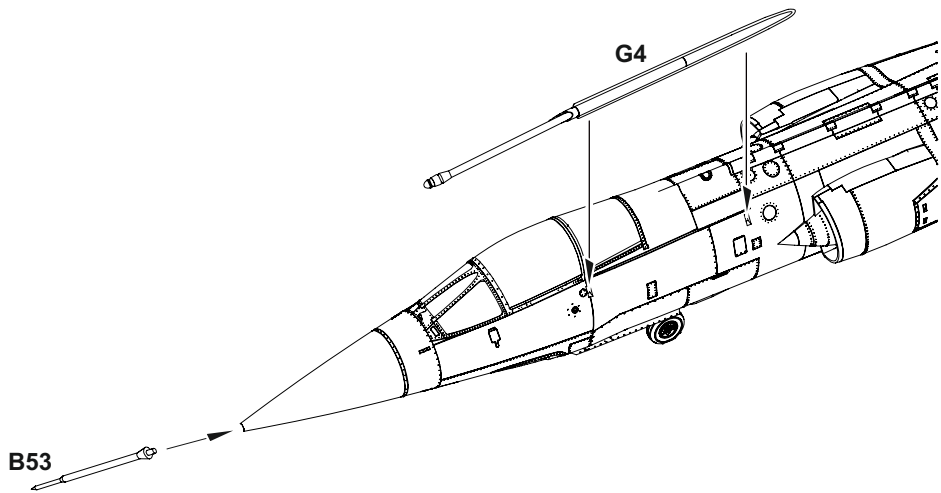

R7 - MARKINGS A, C, E, F, G ONLY

FUEL TANK FOR WINGTIPS ON STARBOARD

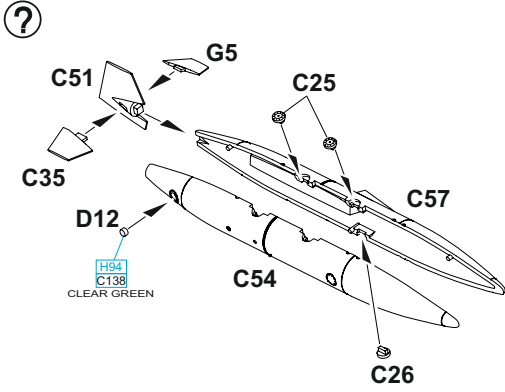

**UNDERWINGS TANK
2 pcs.**

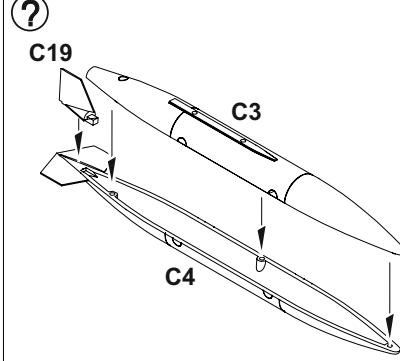

FUEL TANK FOR WINGTIPS ON PORT BOARD

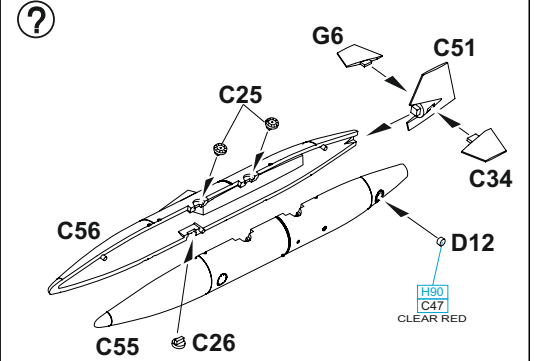

**RED DOG
2 pcs.**

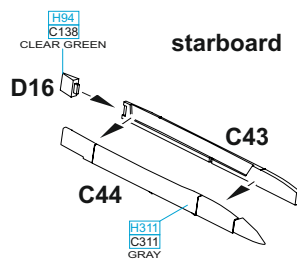
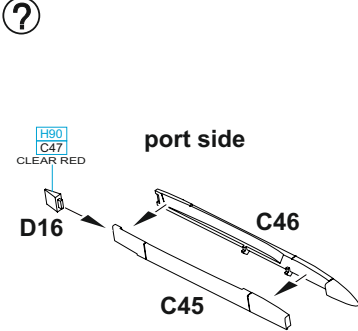

**AIM-9B
2 pcs.**

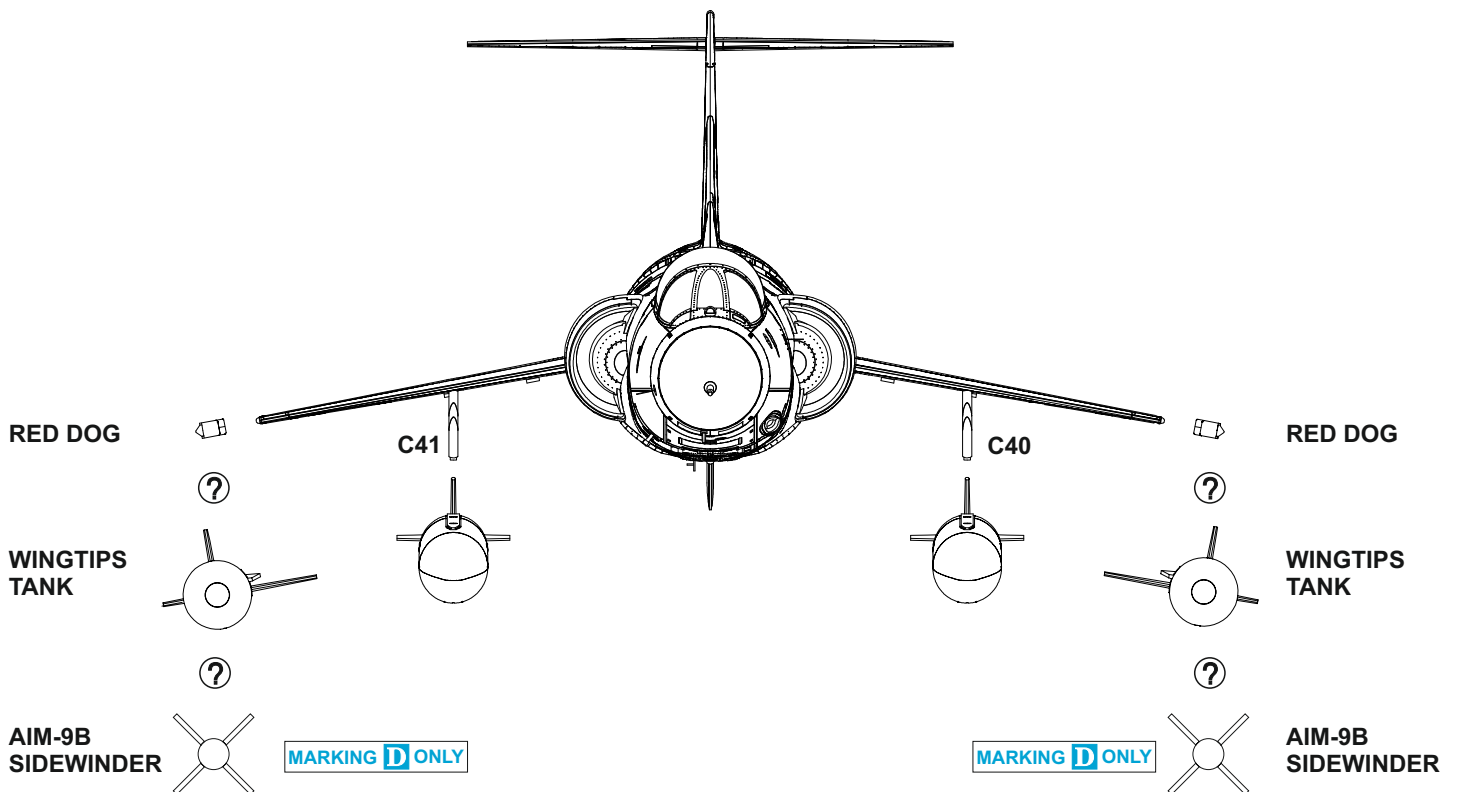
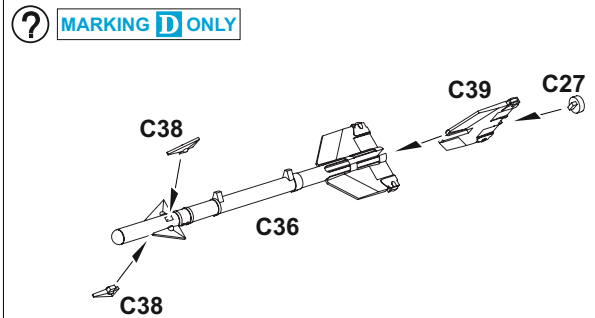

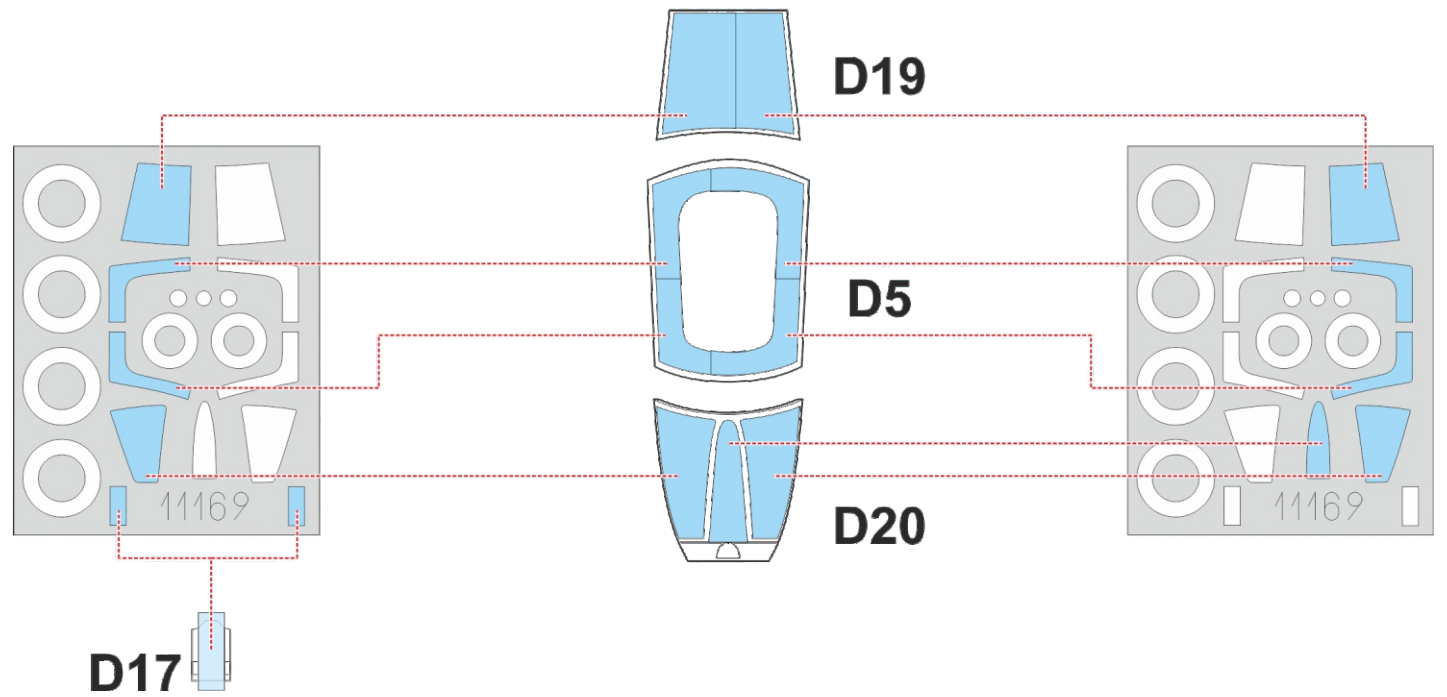
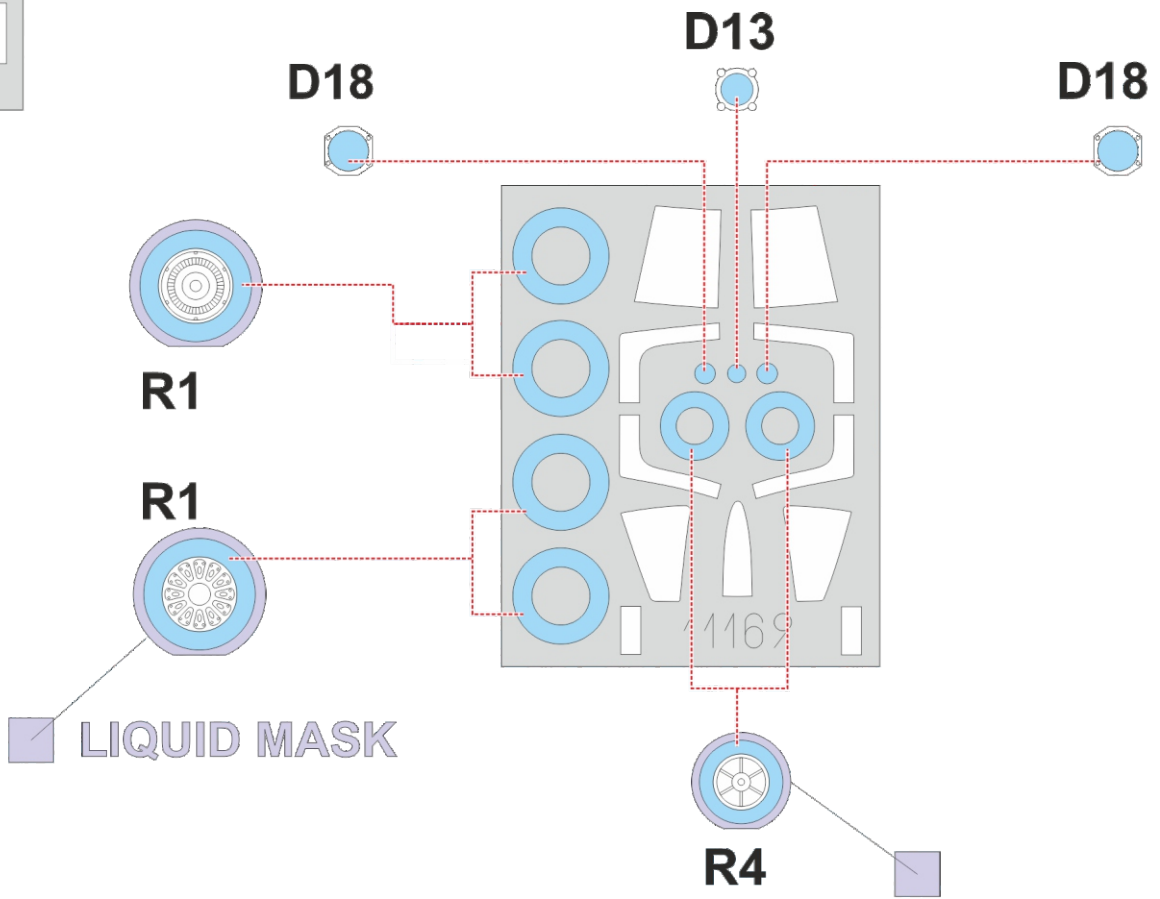

A F-104C-5-LO, 56-0891, Maj. Charles H. Drisko, 435th TFS, 479th TFW, Udorn RTAFB, Thailand, 1967

F-104 serial number 56-0891 arrived in Udorn, Thailand, in January 1967. In the following months it was a personal mount of Major Herb Drisko, who had the ground personnel paint on the port side a cartoon of Snoopy wearing brown leather jacket and yellow scarf flying on the 20mm Vulcan Gatling Gun with its barrels blasting. Under Snoopy there was an inscription "SNOOPY SNIPER". The airplane's starboard was decorated with Herb's wife name Nancy J. After the operations were over, in June 1967 F-104 was flown over to the USA, to Muniz AFB in Puerto Rico. Charles Herbert Drisko, called Herb by his friends, was borne on October 26, 1928, in Bartlesville, OK and after he graduated from the high school, during the period after the war, he worked in the oil fields in Wyoming. In July 1951 he joined the Air Force and after completing the training and receiving his officer's commission he served in the Korean War as a radar operator on F-89 out of Okinawa. After that he completed his pilot training and during the Vietnam war flew F-104. He left the Air Force in 1971 with the rank of Lieutenant Colonel. Herb Drisko passed away on October 26, 2000.

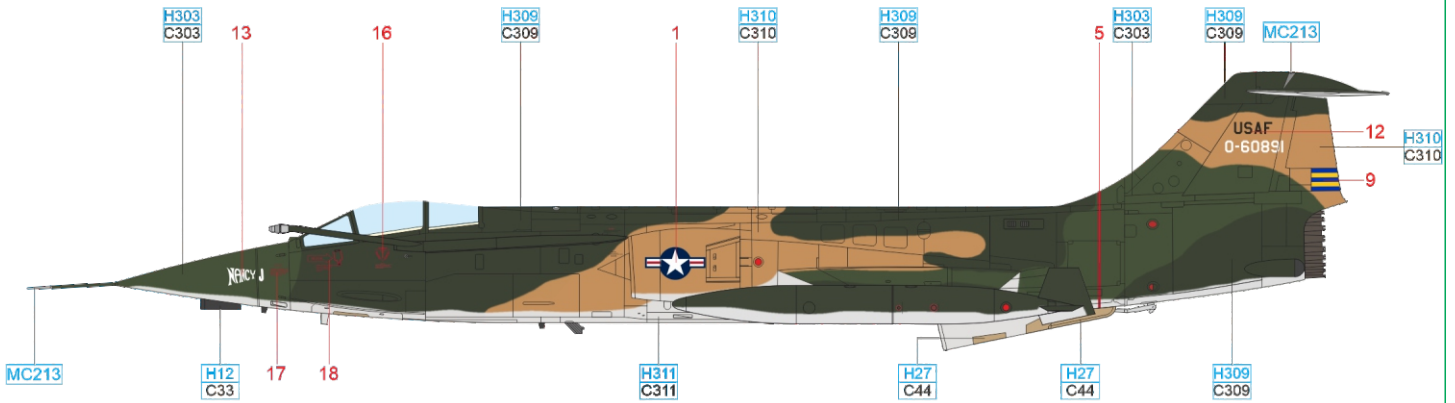

ČESKOU VERZI TEXTU NALEZNETE NA
www.eduard.com
 POD KATALOGOVÝM ČÍSLEM 11169

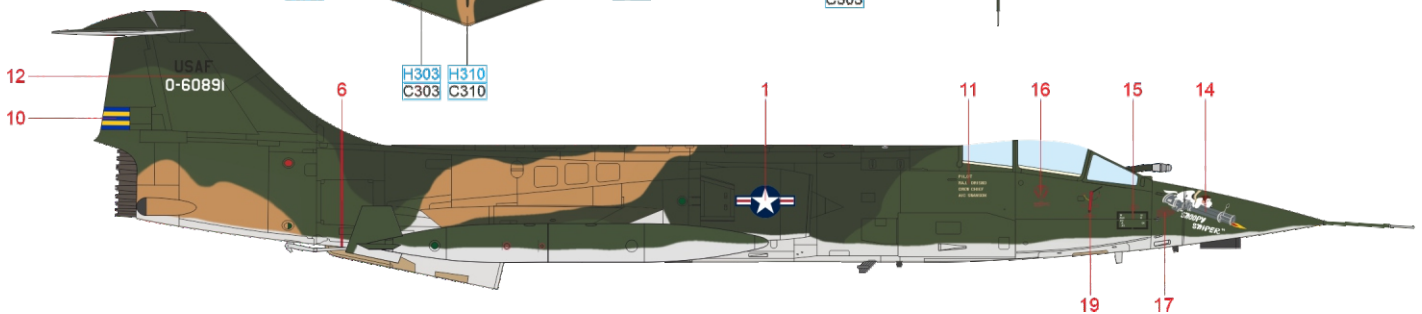
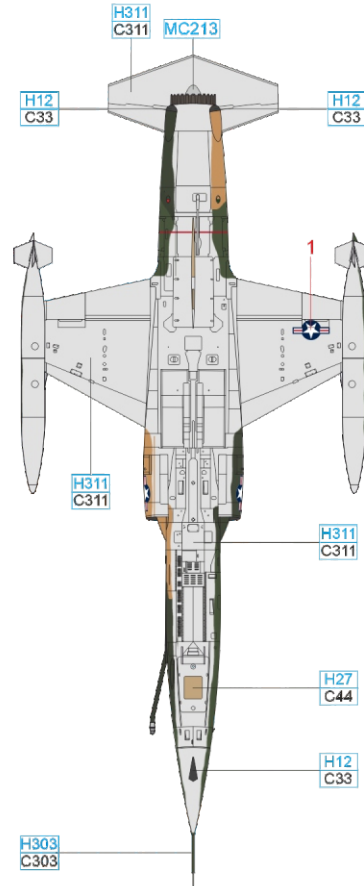
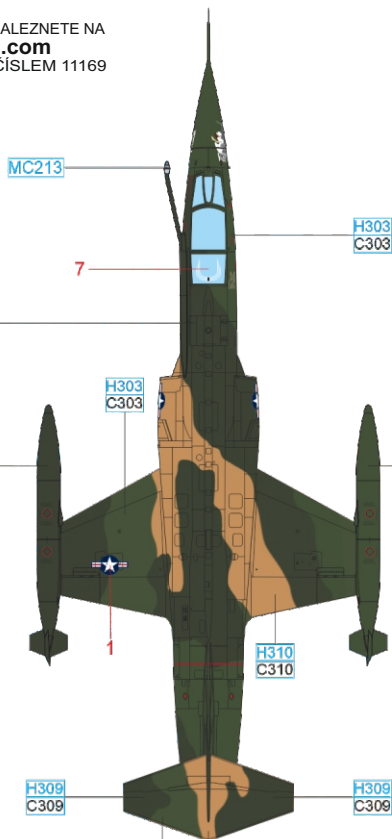

BROWN	H310 C310	GRAY	H311 C311	FLAT BLACK	H12 C33
GREEN	H303 C303	GREEN	H309 C309	TAN	H27 C44
				STAINLESS	MC213

B F-104C-5-LO, 56-0891, Col. George Laven Jr., 479th TFW, George AFB, California, United States, 1959

"SNOOPY SNIPER" history was very colorful. The aircraft serial number 56-0891 was received on October 15, 1958 as the first C-version airframe at Nellis AFB in Las Vegas, Nevada. The aircraft was christened Really George as its home base was supposed to be 479th TFW at George AFB, California. The aircraft was assigned to the commander, Col. George Laven Jr., who was a WWII ace credited with five kills. Same as his previous personal aircraft. Laven's new F-104 sported rather gaudy coloration which gradually developed to the point that the superior officers ordered its removal as it was deemed too wild. It was followed by the more moderate blue coat with four stripes representing colors of all four 479th TFW squadrons. George Laven Jr. was a self-confident Texan known for his daring style of flying. He joined the USAAF in the end of December 1940 and completed his pilot training in August 1941. He gained his fame during his service with 343rd FG flying P-38s and 54th FG in Alaska where he guided P-39s. During this period he scored four aerial victories and he destroyed almost two dozens of locomotives in Europe. In March 1945 he was assigned to the 49th FG Headquarters but regardless he flew combat as much as possible and on April 26, 1945 he shot down H8K2 as his fifth kill. After the war he continued in the service. At George AFB he commanded several groups and wings. In the end of 1950s he was in the command of the 479th TFW. He retired as a veteran of three wars and in 1969 he became a McDonnell Douglas consultant in Israel. He continued flying F-4 Phantom II and F-15 Eagle.

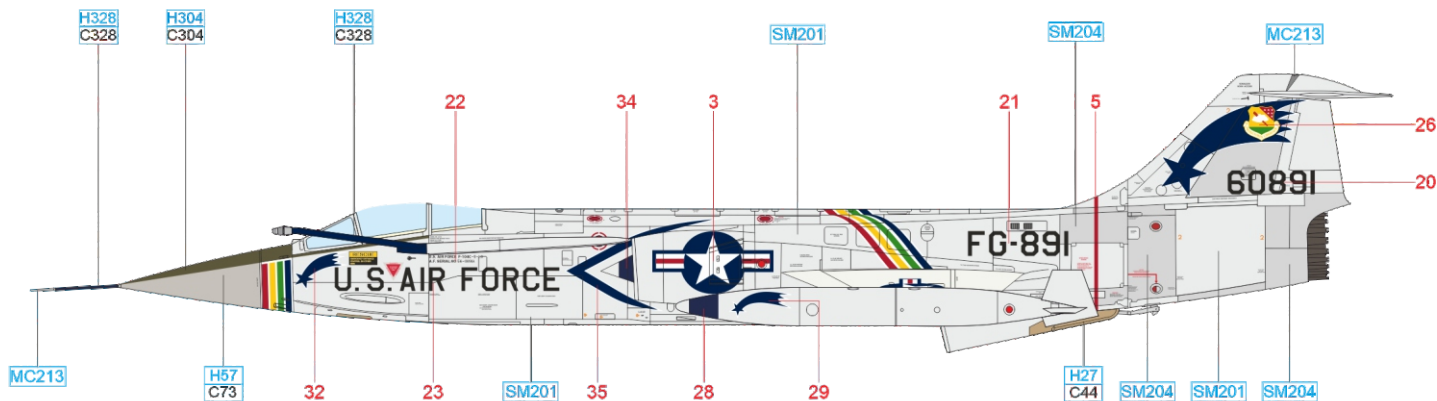

ČESKOU VERZI TEXTU NALEZNETE NA
www.eduard.com
 POD KATALOGOVÝM ČÍSLEM 11169

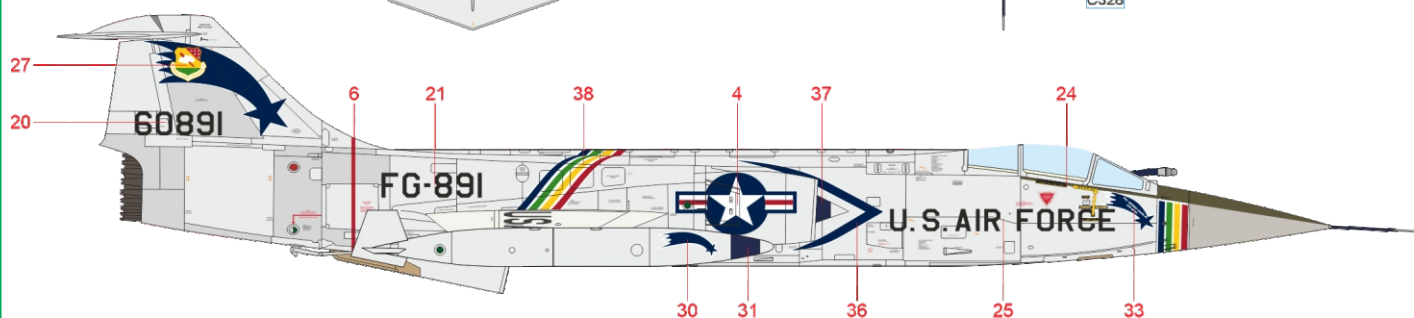
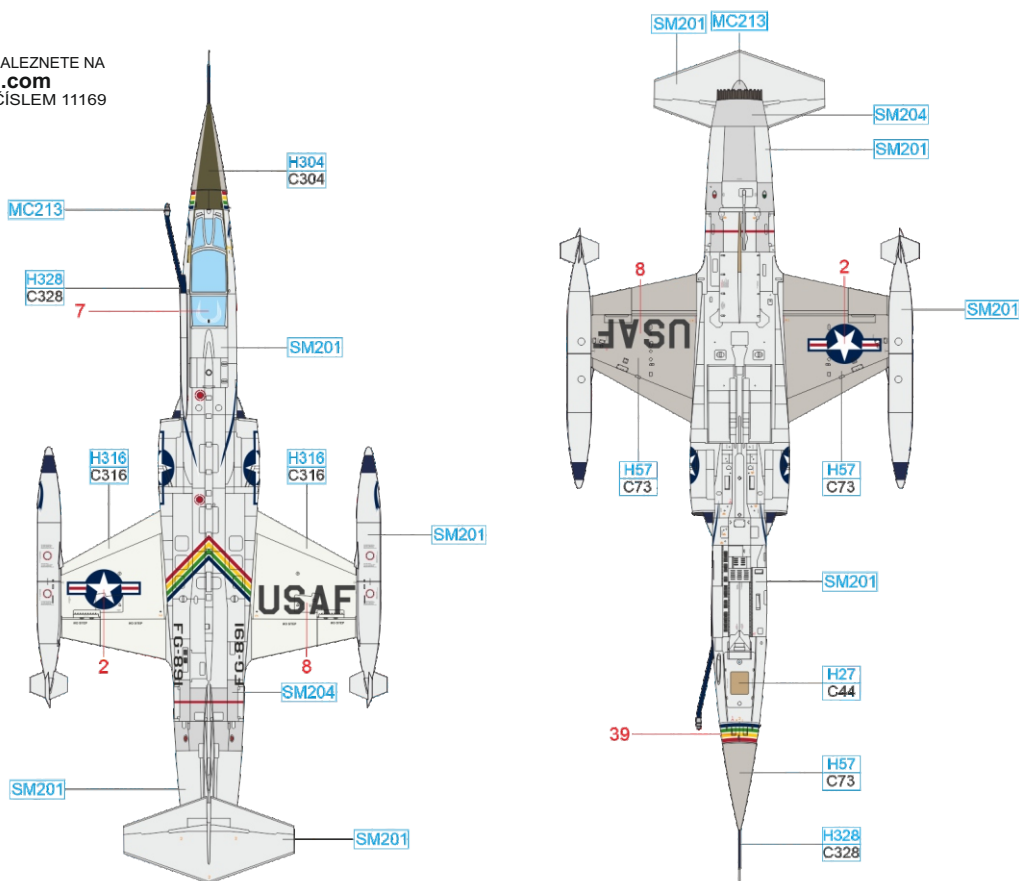

SUPER STAINLESS 2	SM204	AIRCRAFT GRAY	H57 C73	BLUE	H328 C328	TAN	H27 C44
SUPER FINE SILVER 2	SM201	WHITE	H316 C316	OLIVE DRAB	H304 C304	STAINLESS	MC213

F-104 serial number 57-0923 arrived in Udorn on September 19, 1966. It was assigned to the flight commander Lt. Col. Robert Preciado who let both sides of his aircraft nose painted with the nickname of his wife Dolly Helloo Dolly, long Helloo coming from the famous musical Hello Dolly starring Barbra Streisand. After the operations in Udorn were completed, the aircraft was flown back to the USA where, in July 1967, it arrived in Muniz AFB in Puerto Rico. Starting in August 1968 it was assigned to the 198th TFS. Robert Preciado was a veteran of three wars. During WWII he flew in the Pacific with the Air Transport Command and continued his aviation career in Korea and Vietnam.

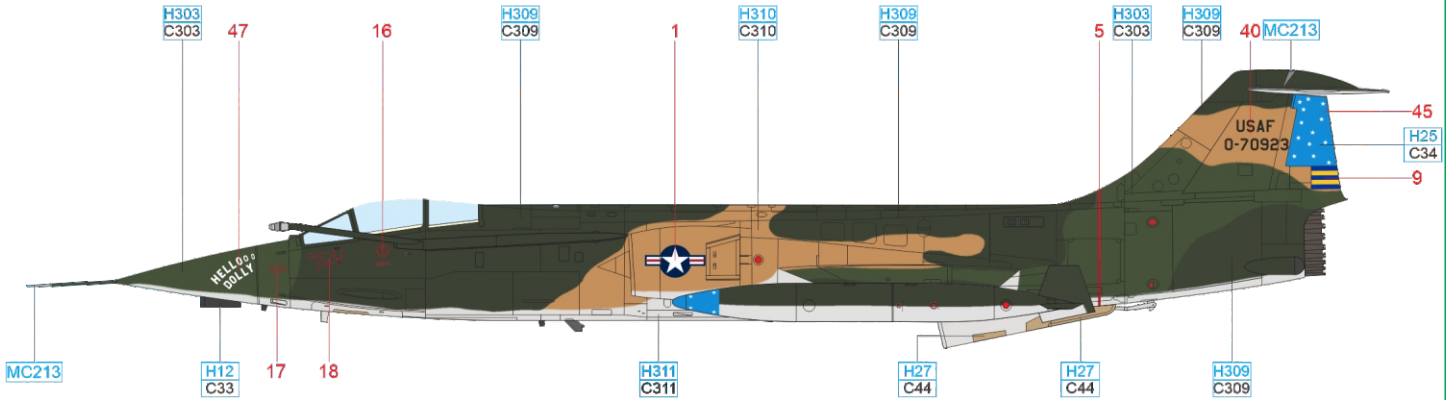

ČESKOU VERZI TEXTU NALEZNETE NA
www.eduard.com
 POD KATALOGOVÝM ČÍSLEM 11169

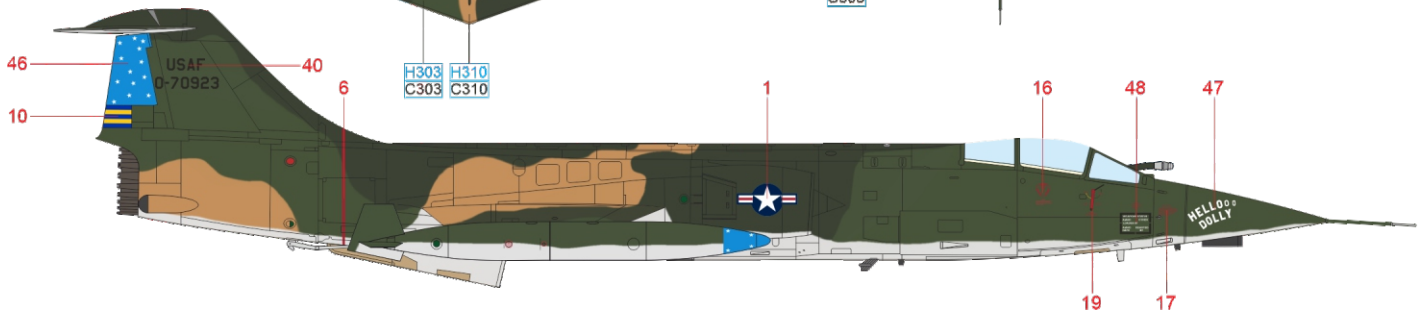
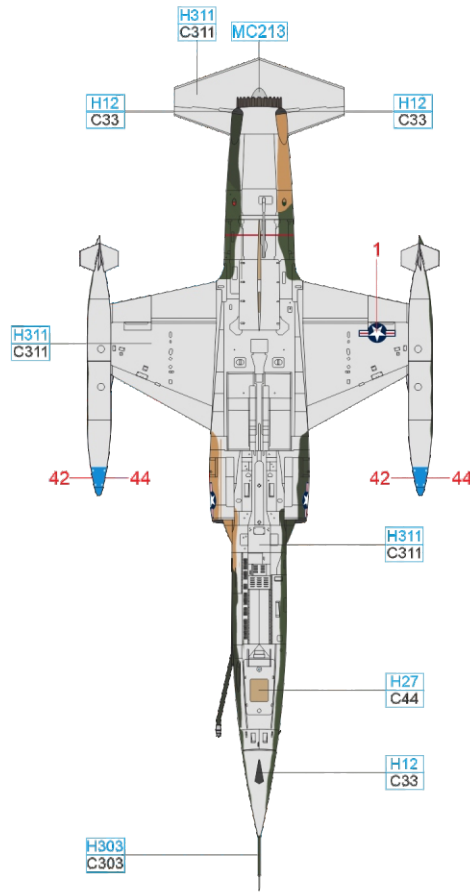
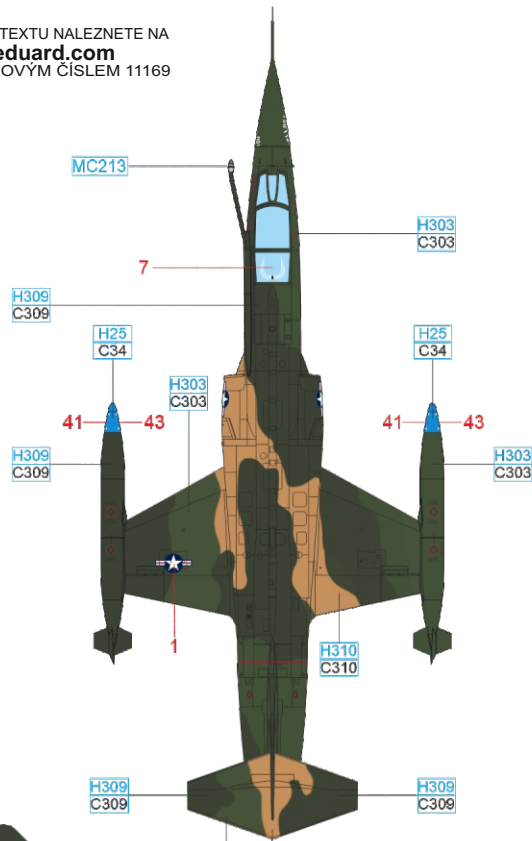

SKY BLUE	H25 C34	FLAT BLACK	H12 C33	BROWN	H310 C310	GRAY	H311 C311
GREEN	H303 C303	GREEN	H309 C309	TAN	H27 C44	STAINLESS	MC213

D F-104C-5-LO, 56-0886, 476th TFS, 479th TFW, Da Nang AB, South Vietnam, April 1965

In 1965 Starfighter serial number 56-0886 flew out of Da Nang airbase in the South Vietnam. Its nose was decorated with the red inscription Fannie and it was one of few 479th TFW planes that had their nicknames painted on the fuselage. In April 1965, the 479th TFW dispatched 28 F-104C to Da Nang airbase. They flew the combat patrols over the bay of Tonkin to protect EC-121 Warning Star nicknamed College Eye or Disco. The effect of the F-104 deployment on the North Vietnamese and Chinese MiG operations was immediate. The Vietnam Peoples Republic's pilots learned very soon to avoid any contact with EC-121 airplanes which were escorted by F-104. During the whole 479th TFW deployment in 1965 only two brief encounters between F-104C and MiGs took place.

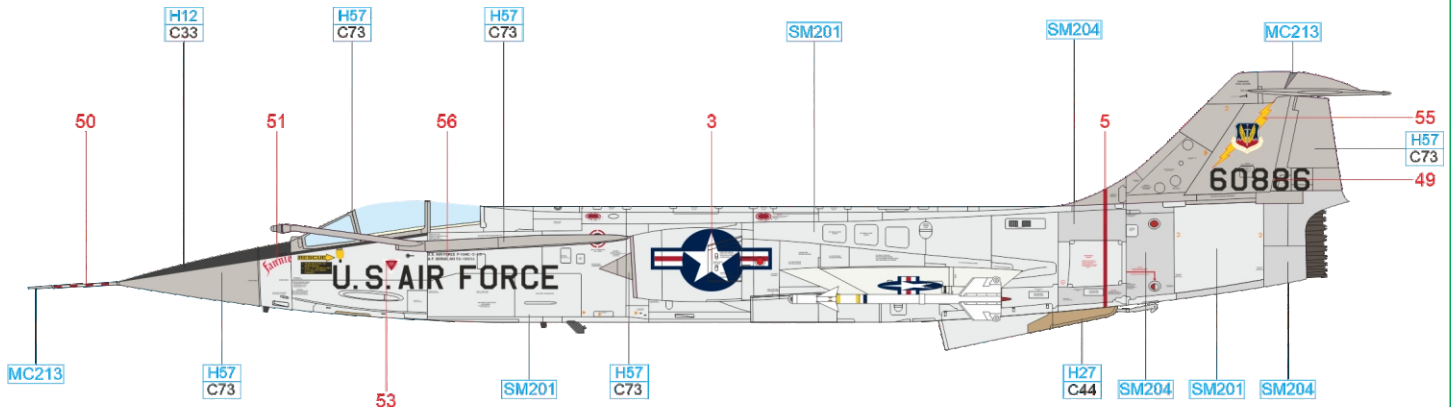

ČESKOU VERZI TEXTU NALEZNETE NA
www.eduard.com
 POD KATALOGOVÝM ČÍSLEM 11169

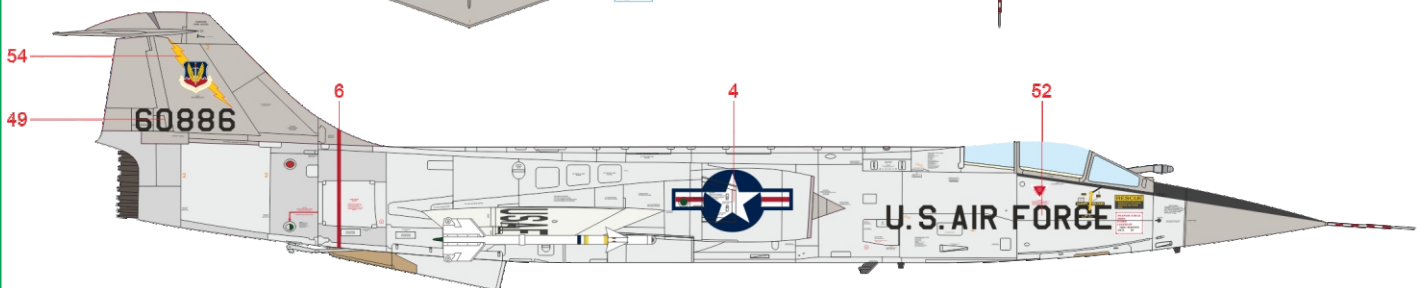
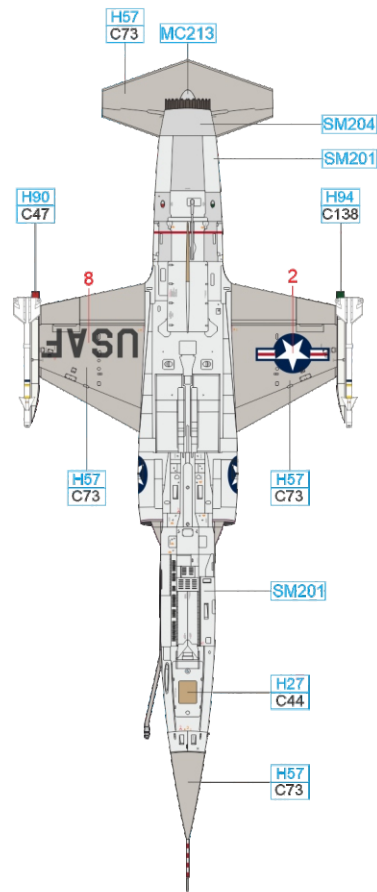
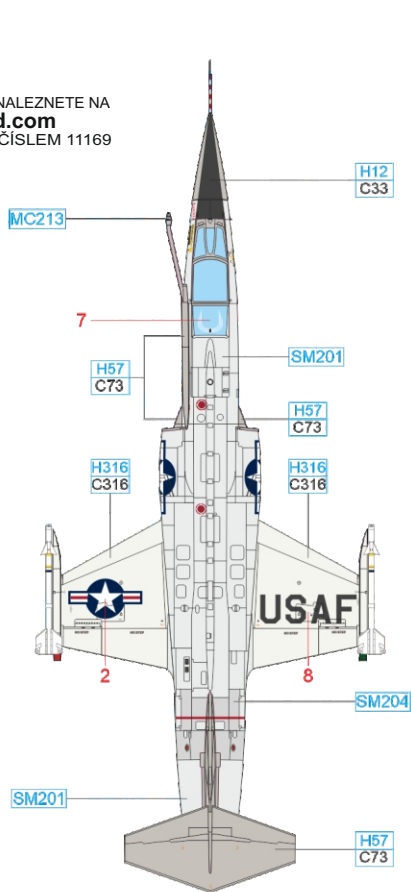

SUPER STAINLESS 2	SM204	AIRCRAFT GRAY	H57 C73	CLEAR RED	H90 C47	CLEAR GREEN	H94 C138
SUPER FINE SILVER 2	SM201	WHITE	H316 C316	FLAT BLACK	H12 C33	TAN	H27 C44
							STAINLESS
							MC213

E F-104C-5-LO, 56-0910, Capt. James B. Trice, 435th TFS, 479th TFW, Udorn RTAFB, Thailand, 1967

One of the first F-104 delivered to the Udorn AFB on June 6, 1966 was Starfighter serial number 56-0910. It was assigned as a personal mount to Capt. James Trice who had his Starfighter nose decorated with a nose art with the inscription PUSSYCAT. Initially the noseart consisted of the cat caricature only, the text was applied later. After the operations in Udorn ceased, in July 1967 the aircraft was flown back to the USA to the Muniz AFB in Puerto Rico and starting in August 1967 it was assigned to the 198th TFS.

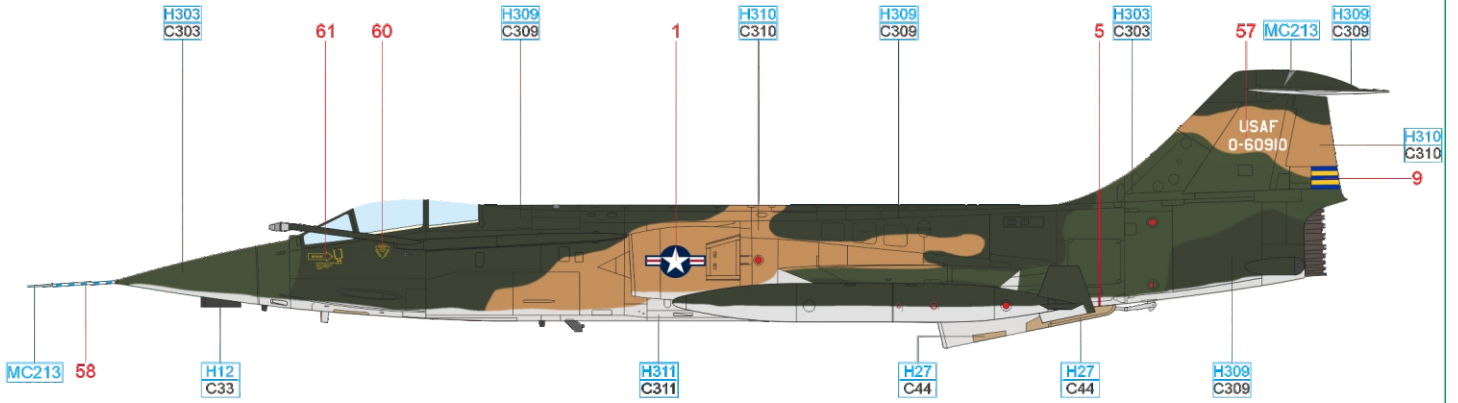

ČESKOU VERZI TEXTU NALEZNETE NA
www.eduard.com
 POD KATALOGOVÝM ČÍSLEM 11169

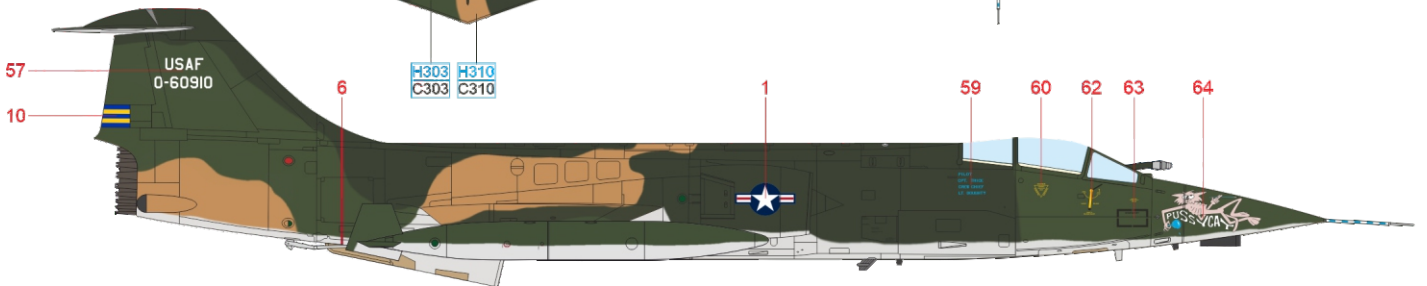
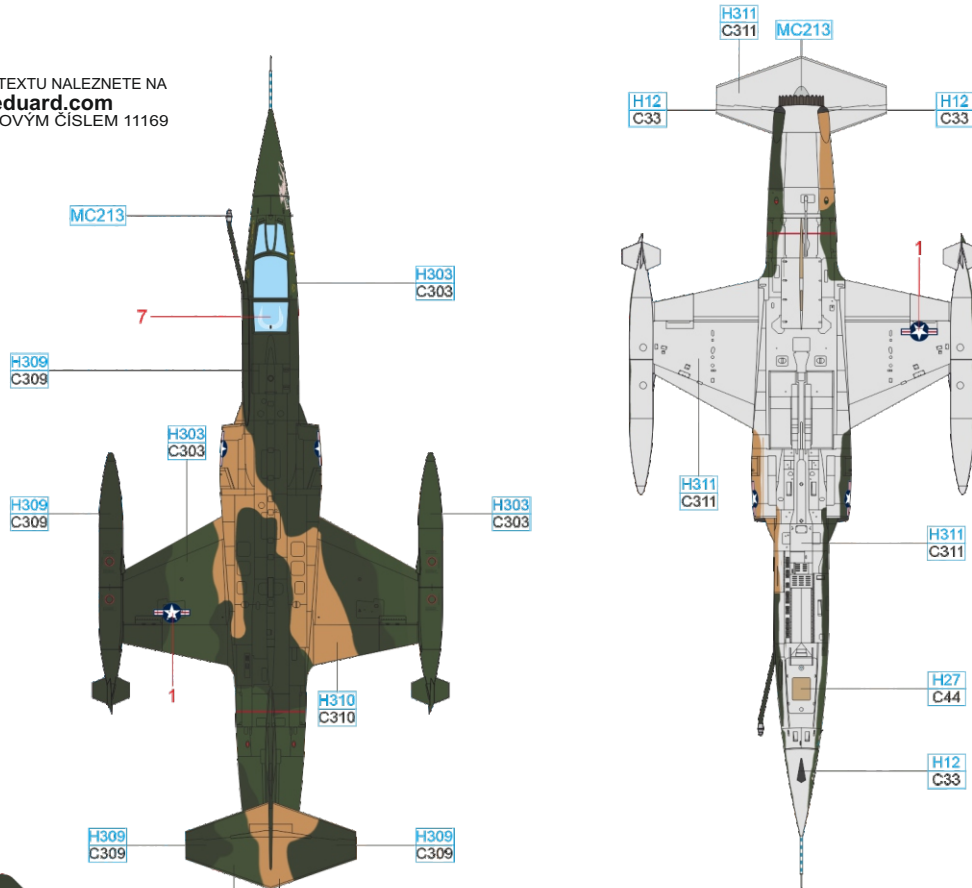

GRAY	H311 C311	TAN	H27 C44	FLAT BLACK	H12 C33
GREEN	H303 C303	GREEN	H309 C309	BROWN	H310 C310
				STAINLESS	MC213

F F-104C-5-LO, 56-0938, Maj. Bobby D. Betsworth, 435th TFS, 479th TFW, Udorn RTAFB, Thailand, June-August 1967

This Starfighter was one of the first eight aircraft of this type delivered to the Udorn AFB on June 6, 1966. It was typically flown by Maj. Bobby Bedsworth who hailed from Missouri nicknamed Show Me State. For that reason the nose of his aircraft was decorated with a mule and this inscription. After the operations in Udorn ceased, on August 20, 1967 the airplane was flown back to the USA to the Muniz AFB in Puerto Rico.

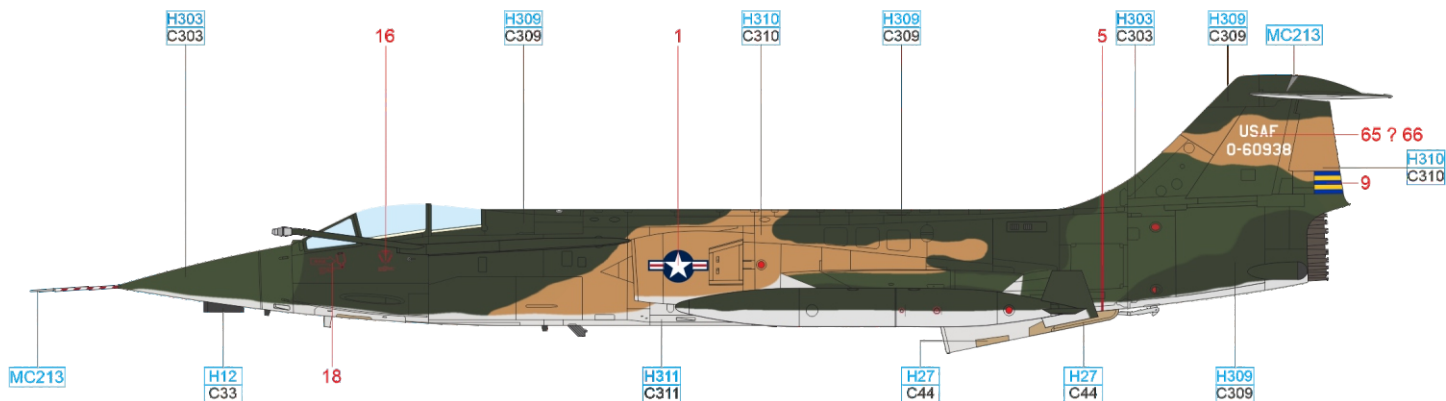

ČESKOU VERZI TEXTU NALEZNETE NA
www.eduard.com
POD KATALOGOVÝM ČÍSLEM 11169

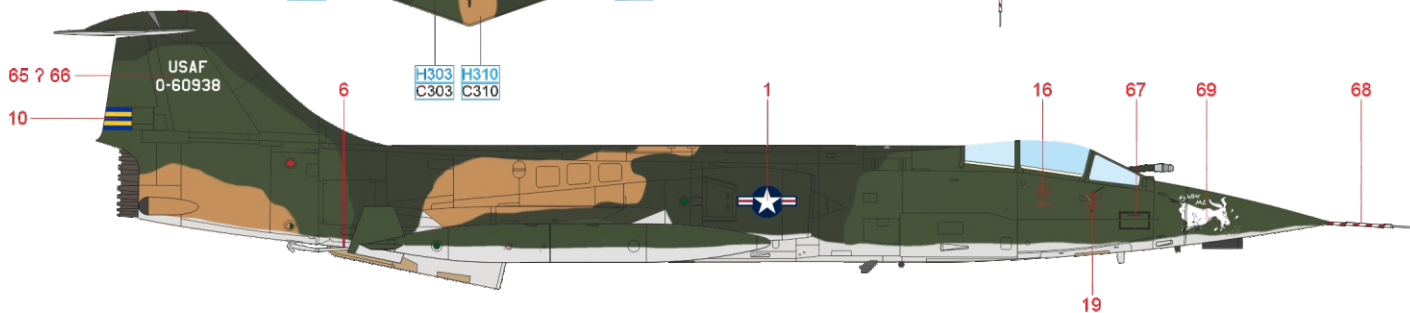
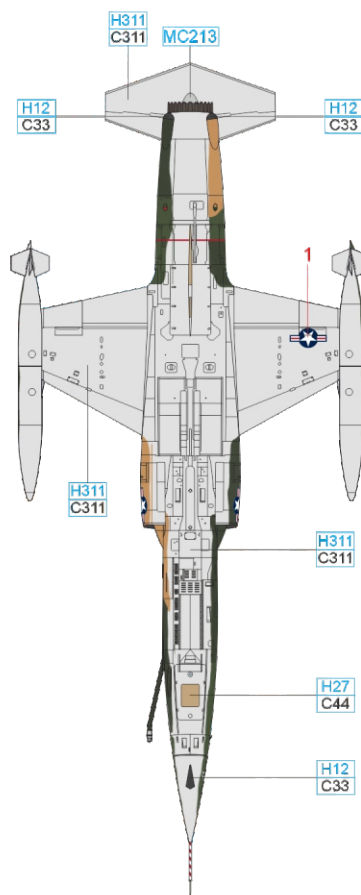
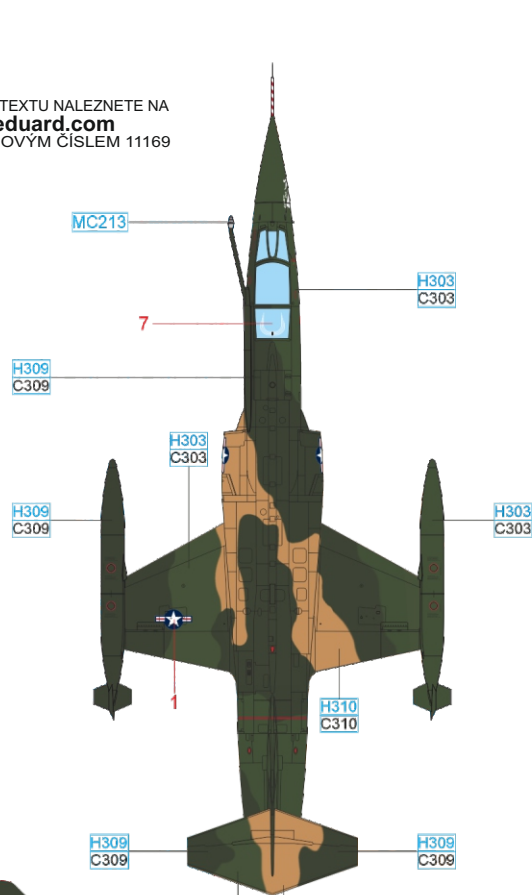

GRAY	H311 C311	TAN	H27 C44	FLAT BLACK	H12 C33
GREEN	H303 C303	GREEN	H309 C309	BROWN	H310 C310
				STAINLESS	MC213

This Starfighter took part in the very first mission in Vietnam in 1965. After the overhaul it was one of twelve aircraft which on July 22, 1966 landed at Udorn. During the following combat missions it was mostly flown by Maj. Hugh Spencer. In March 1967 the pin up girl named SEX MACHINE was painted on the aircraft's nose. After the operations in Udorn were completed, in July 1967 the aircraft was flown back to the USA to the Muniz AFB in Puerto Rico and in August 1967 it was assigned to the 198th TFW. Currently the aircraft is on display in the Kalamazoo Air Zoo Aviation History Museum in its original markings carried while flying at 434th TFS, the large fuselage number FG-898 and red markings.

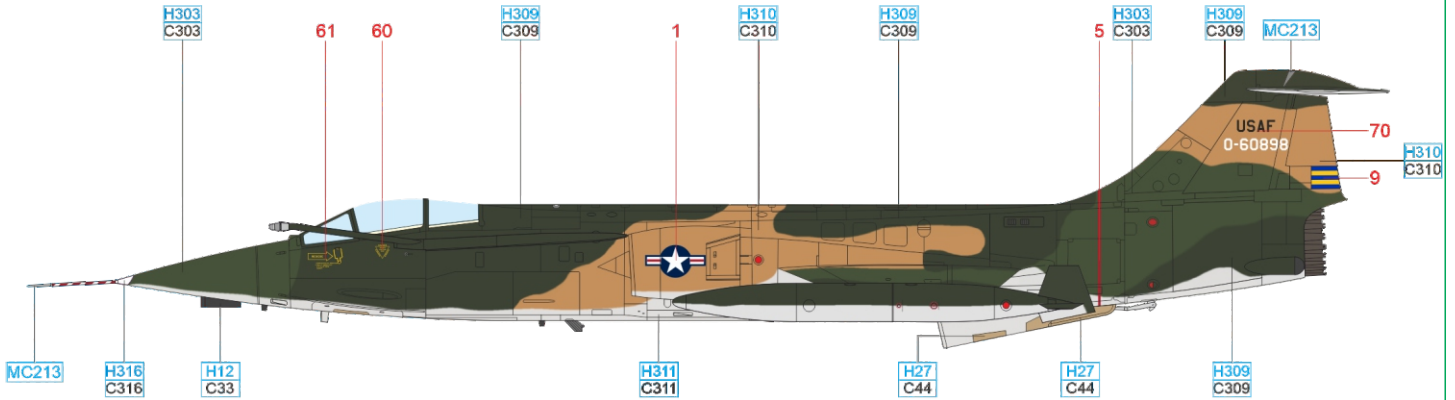

ČESKOU VERZI TEXTU NALEZNETE NA
www.eduard.com
POD KATALOGOVÝM ČÍSLEM 11169

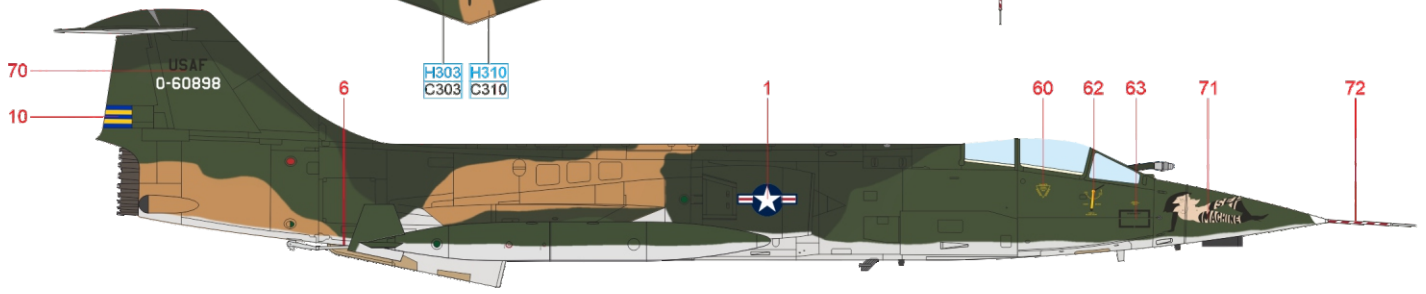
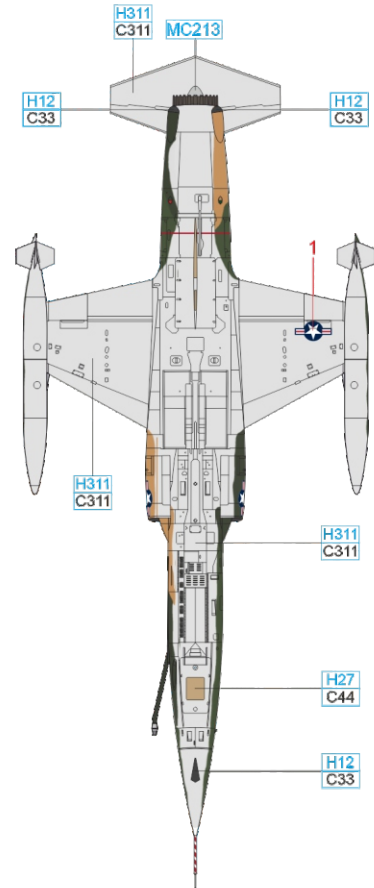
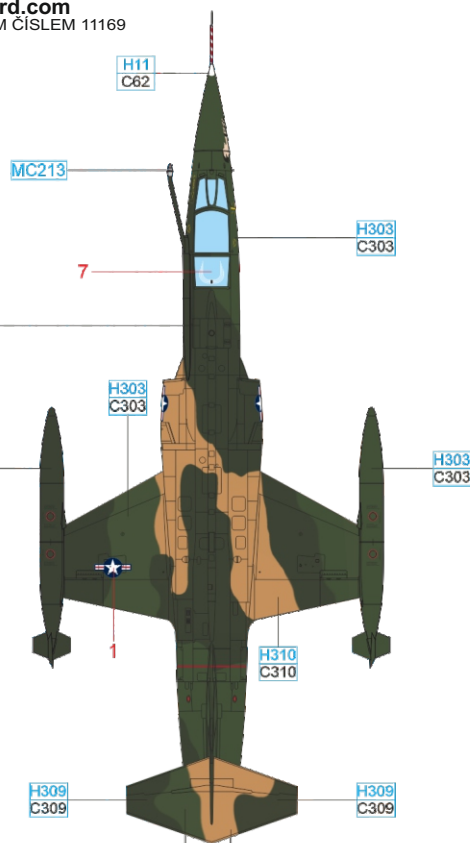

FLAT BLACK	H12 C33	WHITE	H316 C316	BROWN	H310 C310	GRAY	H311 C311
GREEN	H303 C303	GREEN	H309 C309	TAN	H27 C44	STAINLESS	MC213

