



Scale Plastic Model Kit

1/48



SPARVIERO SM.79

The SM.79 Sparviero was an Italian medium bomber developed by Savoia-Marchetti company. The aircraft was easily recognizable thanks to its three-engine concept and fuselage's distinctive dorsal hump.

The Sparviero (Sparrowhawk in English) was liked by its crews and the airmen nicknamed it "il gobbo maledetto" (Damned Hunchback). The original development of SM.79 dates back to early 1930s. From the very start, it was designed as a fast passenger or cargo cantilever low-wing monoplane of combined wood and metal construction. The successful design was proving itself from the very beginning and the SM.79 became the fastest aircraft of its contemporaries within similar category. It made its maiden flight on September 28, 1934, with Adriano Bacula factory pilot behind the controls. And it did not take too long and the new aircraft established 26 aviation world records in the period from 1937 to 1939! The performance of the new type attracted attention of the Regia Aeronautica (Italian Air Force) representatives who looked at it as a prospective fast bomber. In fact, it was the fastest of the medium bombers of its time and the Fascist government readily used the SM.79s as a propaganda tool on many occasions like air meetings or fly-overs during national celebrations. The design was both rugged and responsive enough to allow it to be looped. Quite impressive for such a heavy aircraft.

The SM.79 first saw combat during the Spanish Civil War, where these aircraft usually operated without any fighter escort. This tactics was possible thanks to the speed of the three-engined beast. Thanks to the encouraging performance during the Spanish War, several countries were interested in buying these modern aircraft with Yugoslavia and Romania procuring the type. At the start of the Second World War, almost 600 Sparviero aircraft of SM.79-I and SM.79-II versions were in service in May 1940. Thereafter, they were deployed everywhere Italians fought. The SM.79 was initially used mainly as a medium bomber and transport aircraft. Following pioneering work by the Special Aerotorpedoes Unit, the type was also modified as a torpedo bomber. In this role, the SM.79 achieved notable success against Allied shipping in the Mediterranean theatre. Its wooden structure was light enough to allow it to stay afloat for half an hour in case of water landing. The SM.79 was the most numerous Italian bomber of the WWII, as some 1,300 units were built, and the type remained in Italian service until 1952.



Carefully read instruction sheet before assembling. When you use glue or paint, do not use near open flame and use in well ventilated room. Keep out of reach of small children. Children must not be allowed to suck any part, or pull vinyl bag over the head.



Před započítím stavby si pečlivě prostudujte stavební návod. Při používání barev a lepidel pracujte v dobře větrané místnosti. Lepidla ani barvy nepoužívejte v blízkosti otevřeného ohně. Model není určen malým dětem, mohlo by dojít k požití drobných dílů.

INSTRUCTION SIGNS

* INSTR. SYMBOLS

* INSTRUKTION SINNBILDEN

* SYMBOLES

* 記号の説明



OPTIONAL
VOLBA



BEND
OHNOUT



SAND
BROUSIT



OPEN HOLE
VYVRTAT OTVOR



SYMETRICAL ASSEMBLY
SYMETRICKÁ MONTÁŽ



REMOVE
ODŘÍZNOUT



REVERSE SIDE
OTOČIT



APPLY EDUARD MASK
AND PAINT
POUŽIT EDUARD MASK
NABARVIT

PLEASE CHECK THE LATEST VERSION OF THE INSTRUCTIONS ON www.eduard.com

PARTS



DÍLY



TEILE



PIÈCES



部品

PLASTIC PARTS

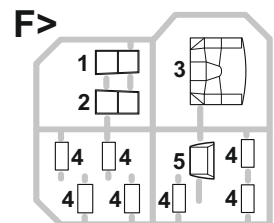
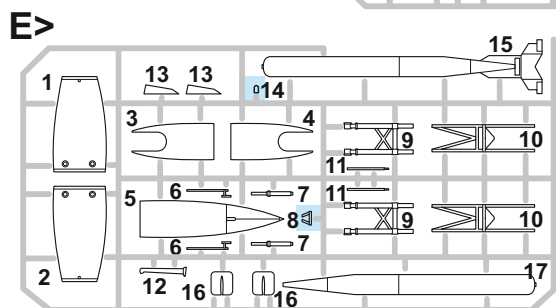
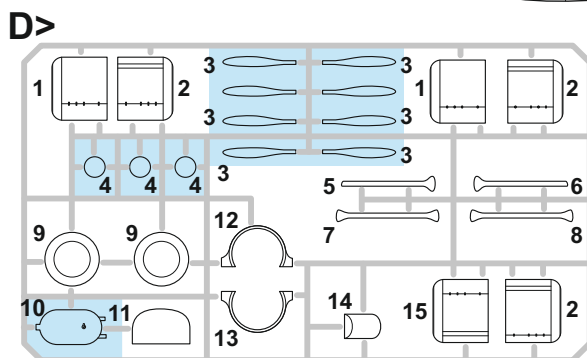
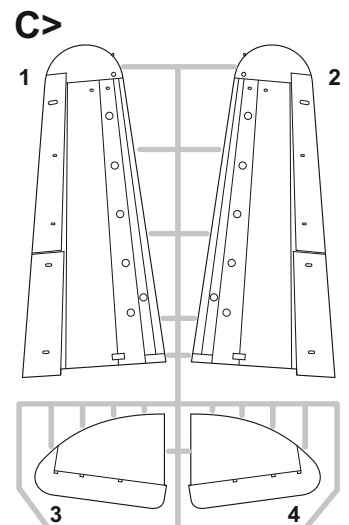
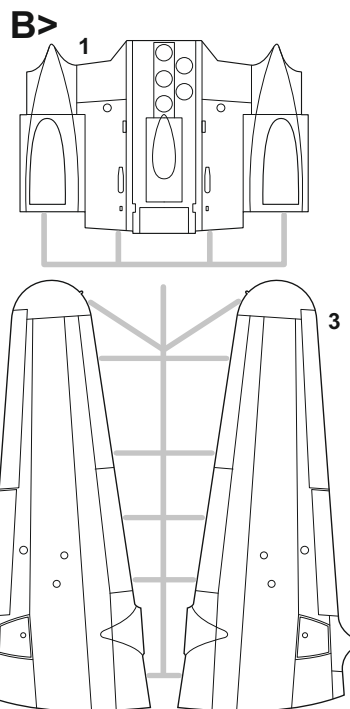
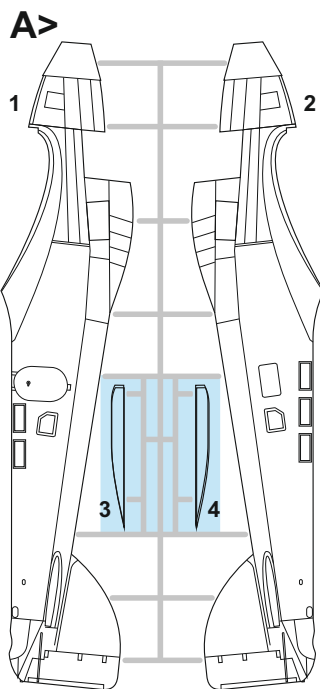

PE - PHOTO ETCHED DETAIL PARTS

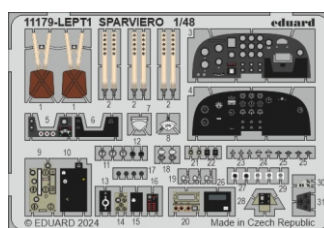
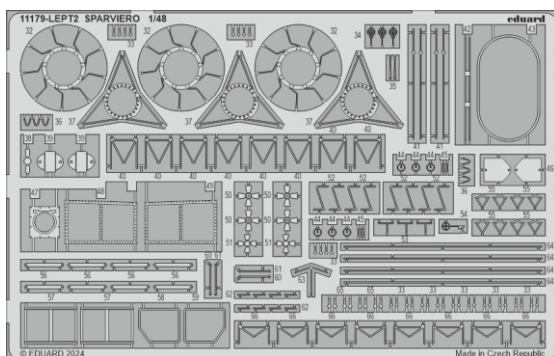

eduard
MASK

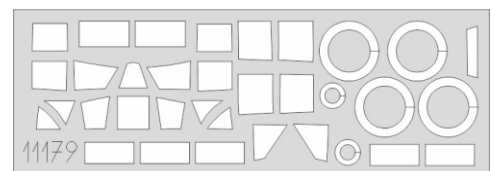

RP - RESIN PARTS
eduard
BRASSIN

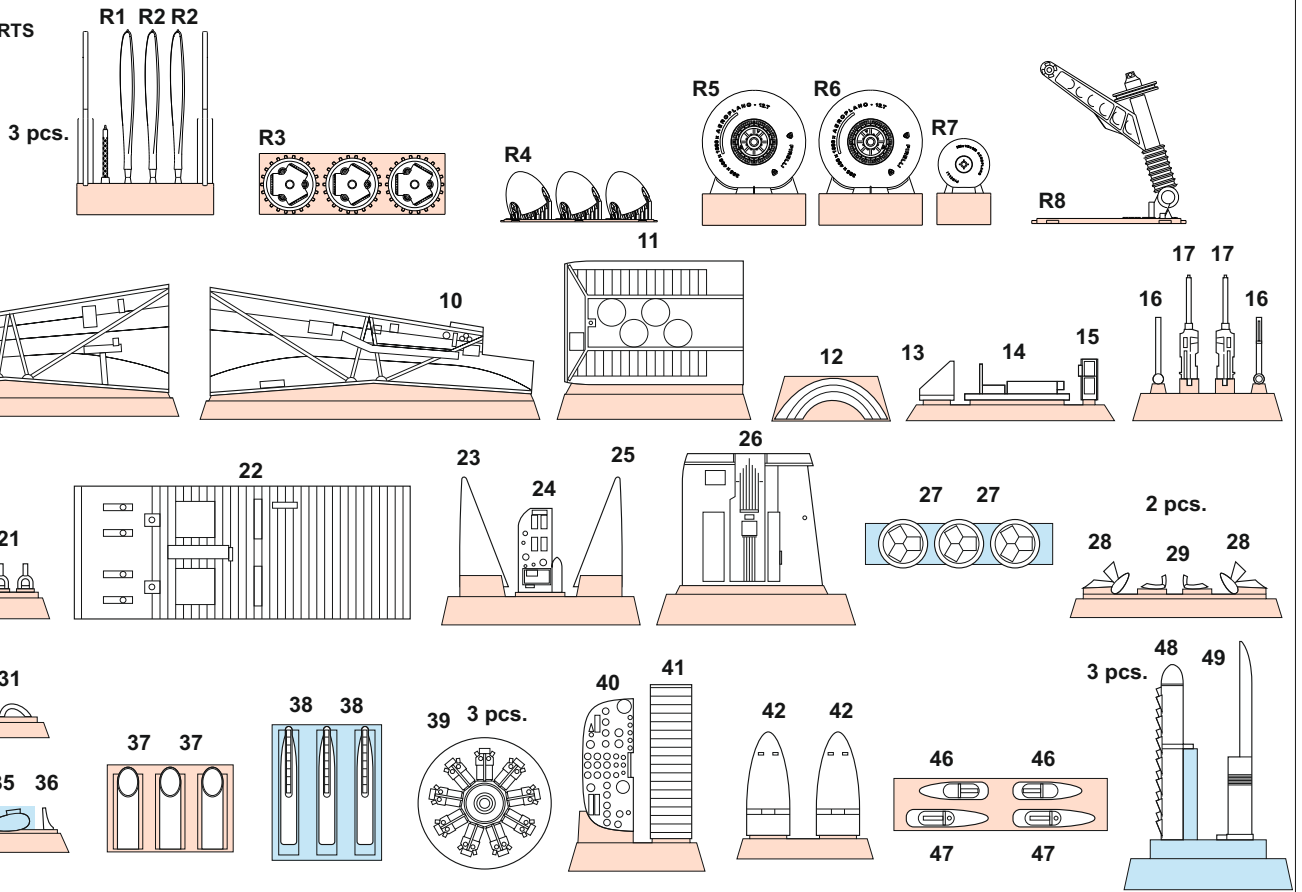

Parts not for use. -Teile werden nicht verwendet. -Pièces à ne pas utiliser. -Tyto díly nepoužívejte při stavbě. - 使用しない部品

COLOURS * BARVY * FARBEN * PEINTURE * 色

GSI Creos (GUNZE)		
AQUEOUS	Mr.COLOR	
H2	C2	BLACK
H7	C7	BROWN
H8	C8	SILVER
H11	C62	FLAT WHITE
H12	C33	FLAT BLACK
H25	C34	SKY BLUE
H37	C43	WOOD BROWN
H47	C41	RED BROWN
H56	C366	INTERMEDIATE BLUE
H58	C351	INTERIOR GREEN

GSI Creos (GUNZE)		
AQUEOUS	Mr.COLOR	
H65	C18	RLM70 BLACK GREEN
H72	C369	DARK EARTH
H77	C137	TIRE BLACK
H79	C39	SANDY YELLOW
H302	C302	GREEN
H312	C312	GREEN
H317	C317	GRAY
H324	C324	LIGHT GRAY
H335	C363	MEDIUM SEAGRAY
H337	C337	GRAYISH BLUE

GSI Creos (GUNZE)		
AQUEOUS	Mr.COLOR	
H417	C117	RLM76 LIGHT BLUE
	C352	CHROMATE YELLOW
Mr.METAL COLOR		
MC215		COPPER
MC218		ALUMINIUM
MC219		BRASS
Mr.COLOR SUPER METALLIC		
SM201		SUPER FINE SILVER
SM203		SUPER IRON 2

OPTIONAL: decal K1

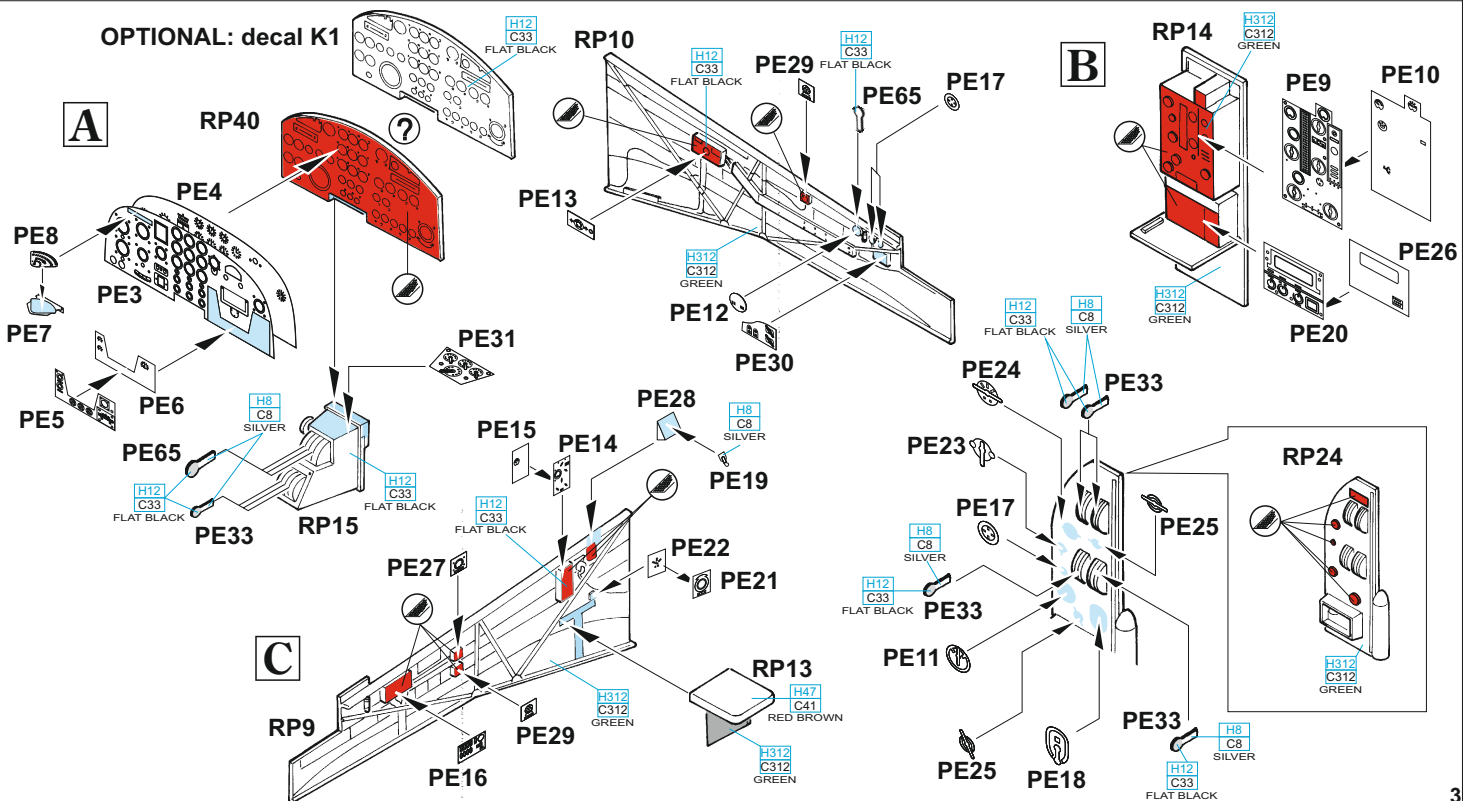

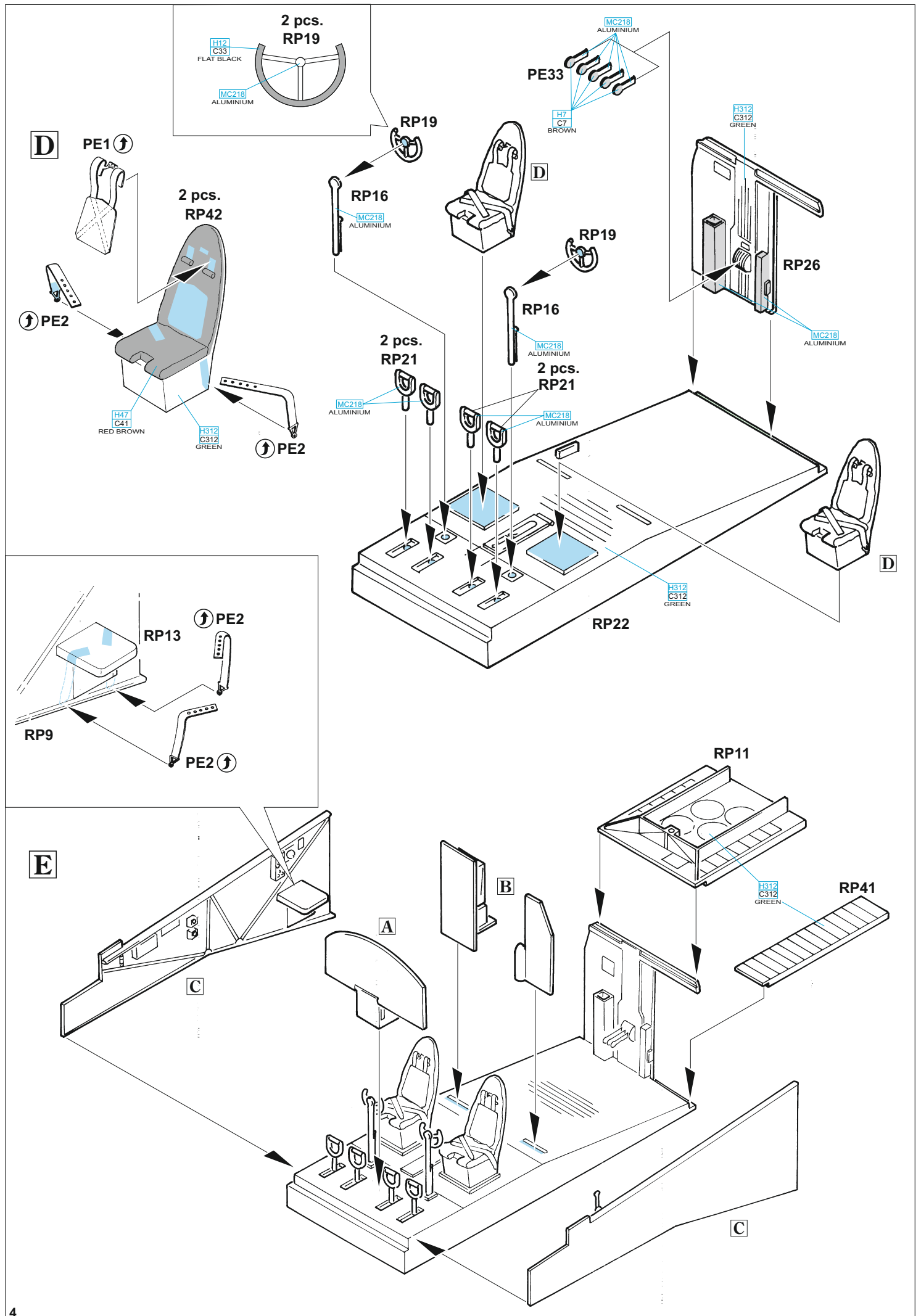

OPEN

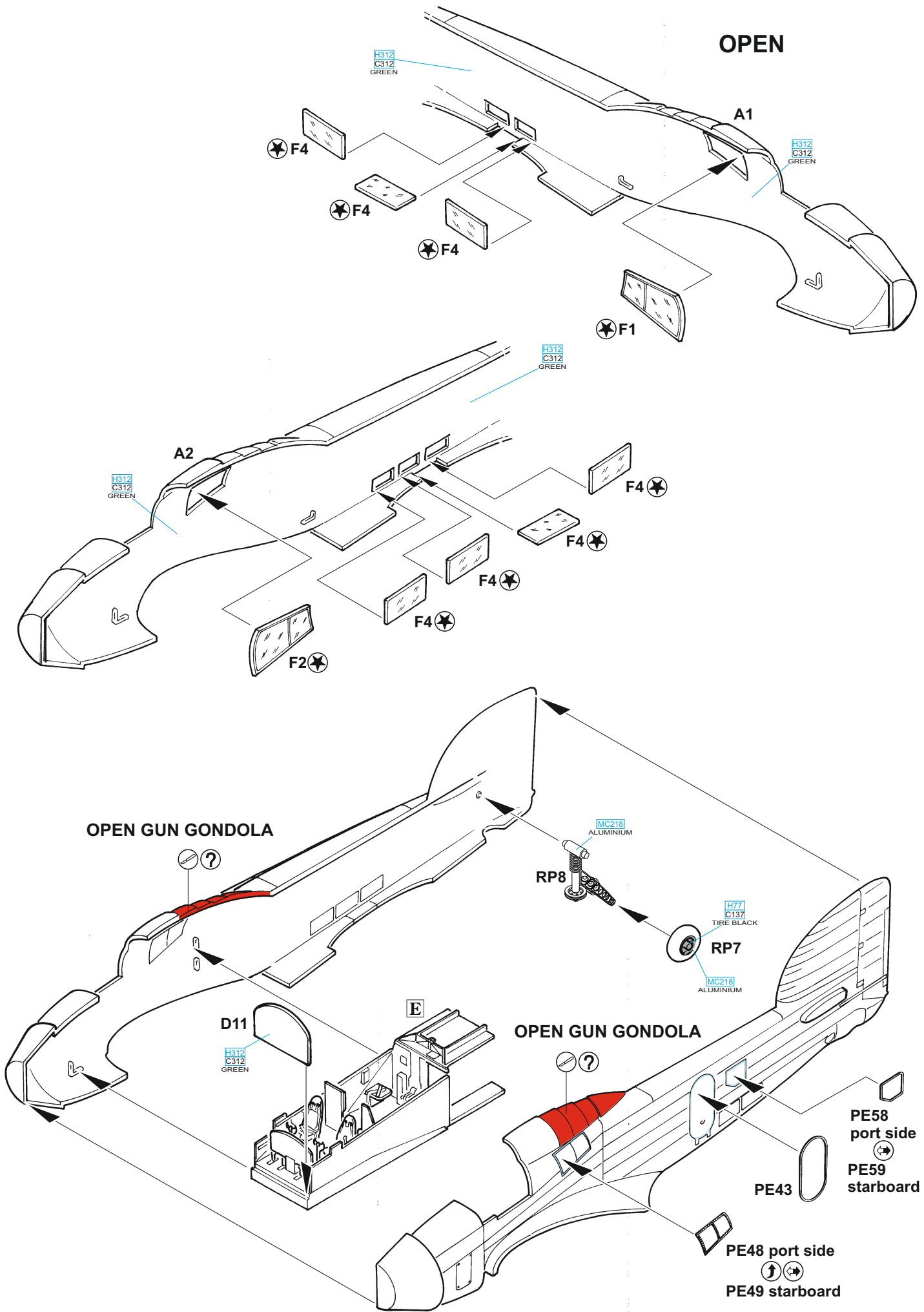

CLOSED GUN GONDOLA

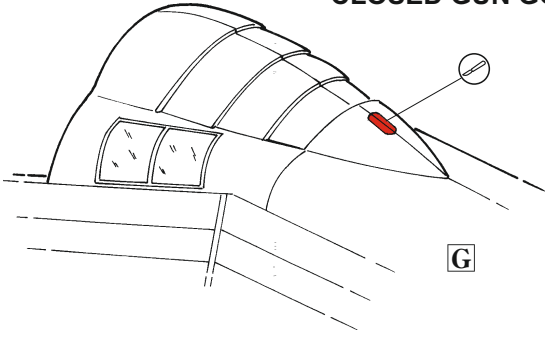

OPEN

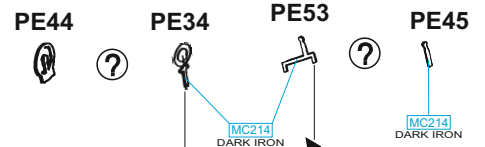
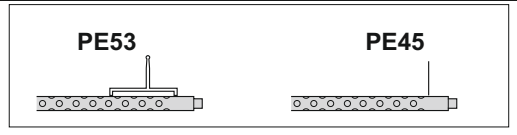

?

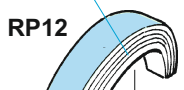
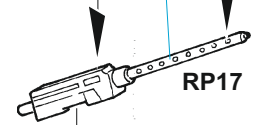

PLASTIC
∅ - 1 mm
l - 2 mm

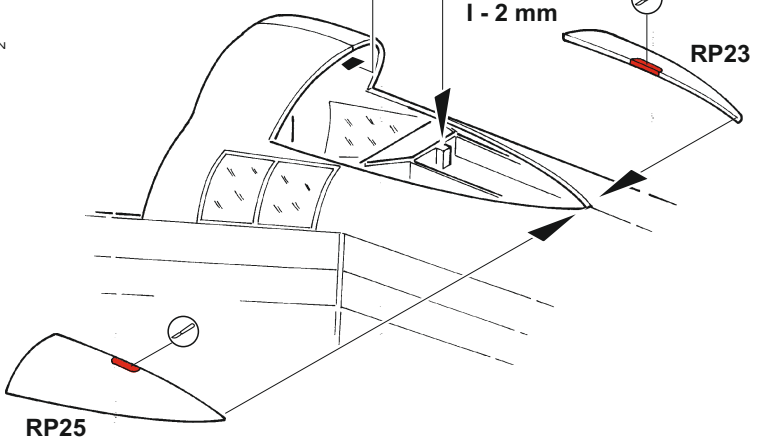
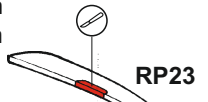

RP25

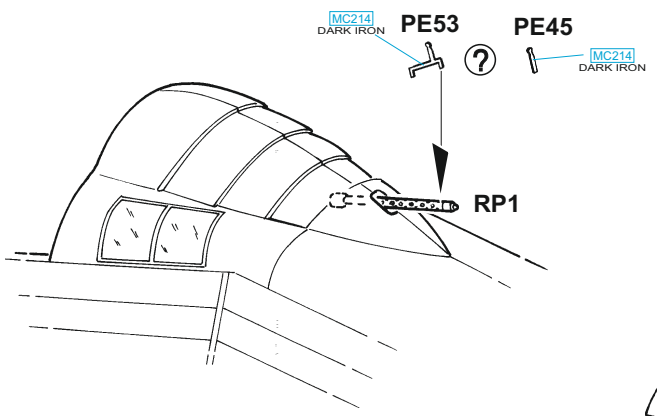

C3

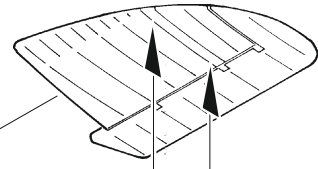

D8

D6

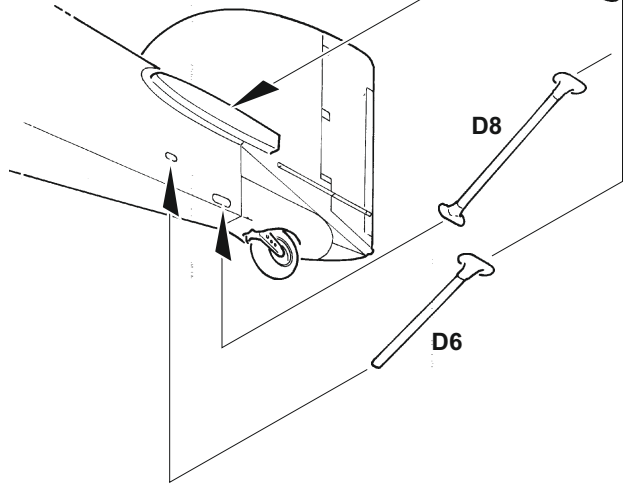

C4

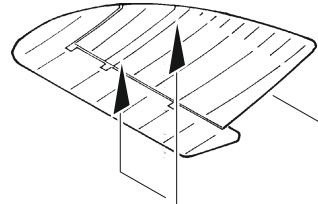

D7

D5

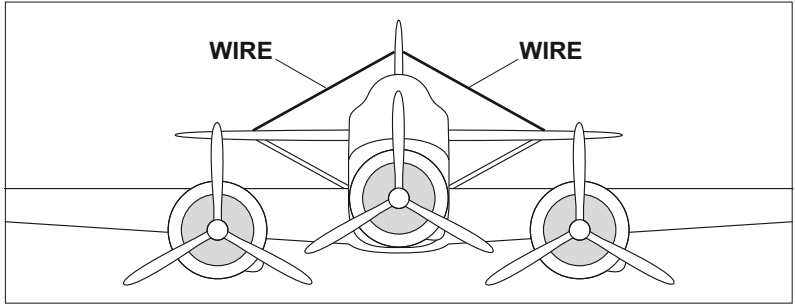
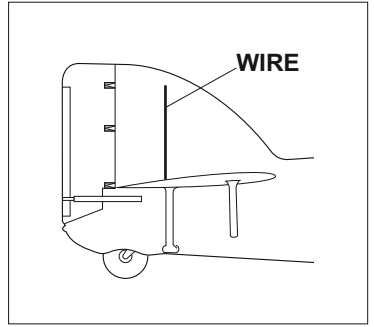
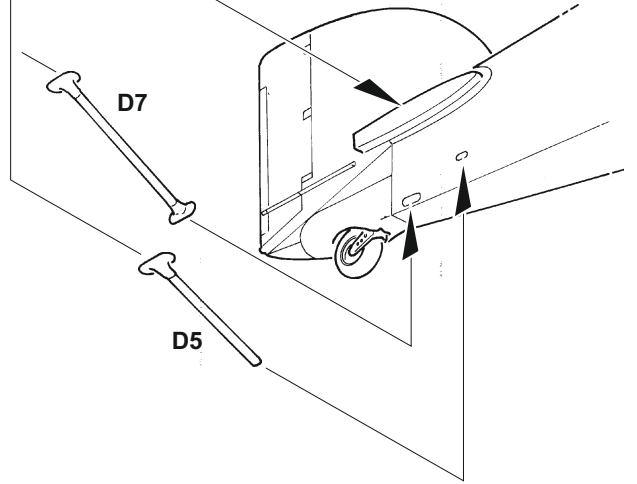

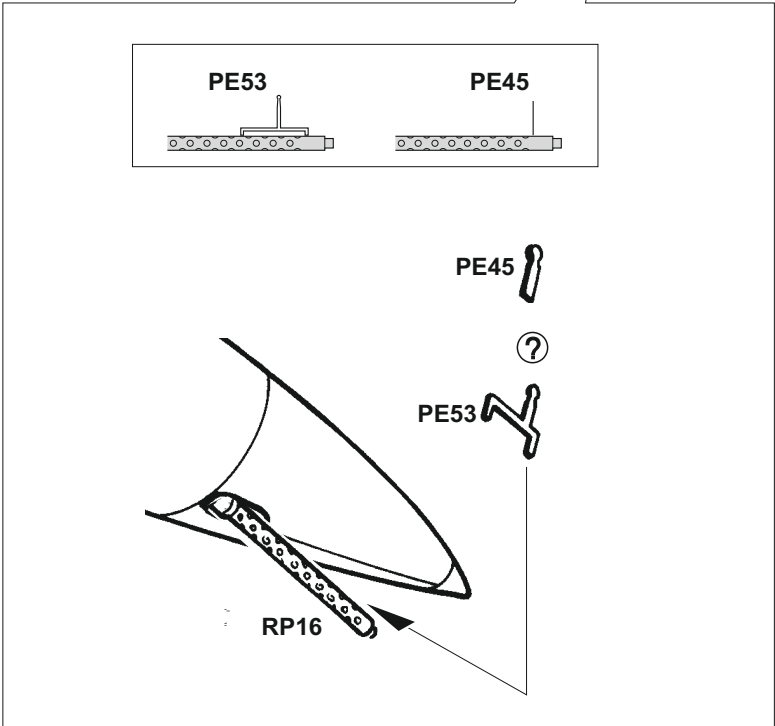
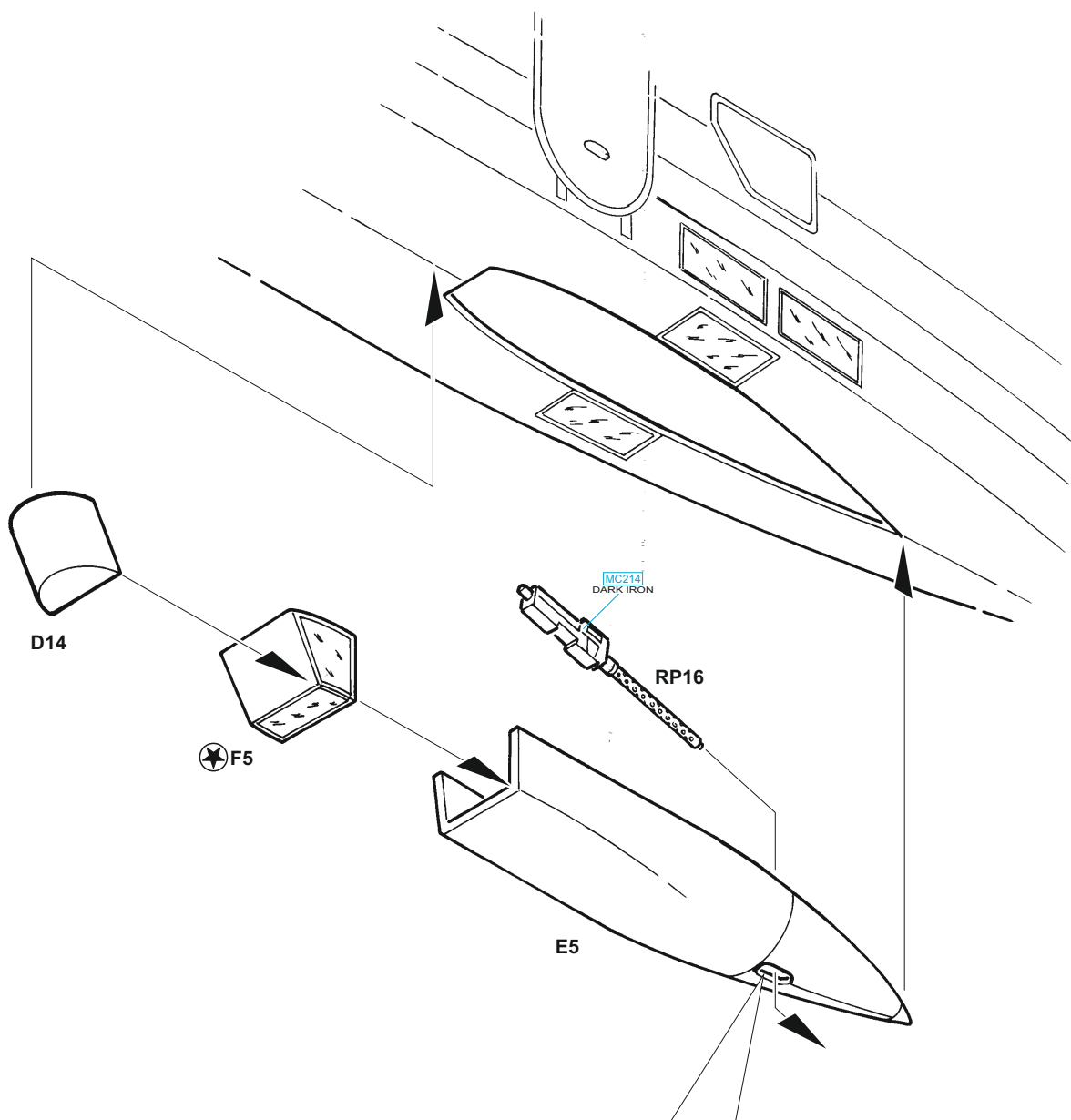

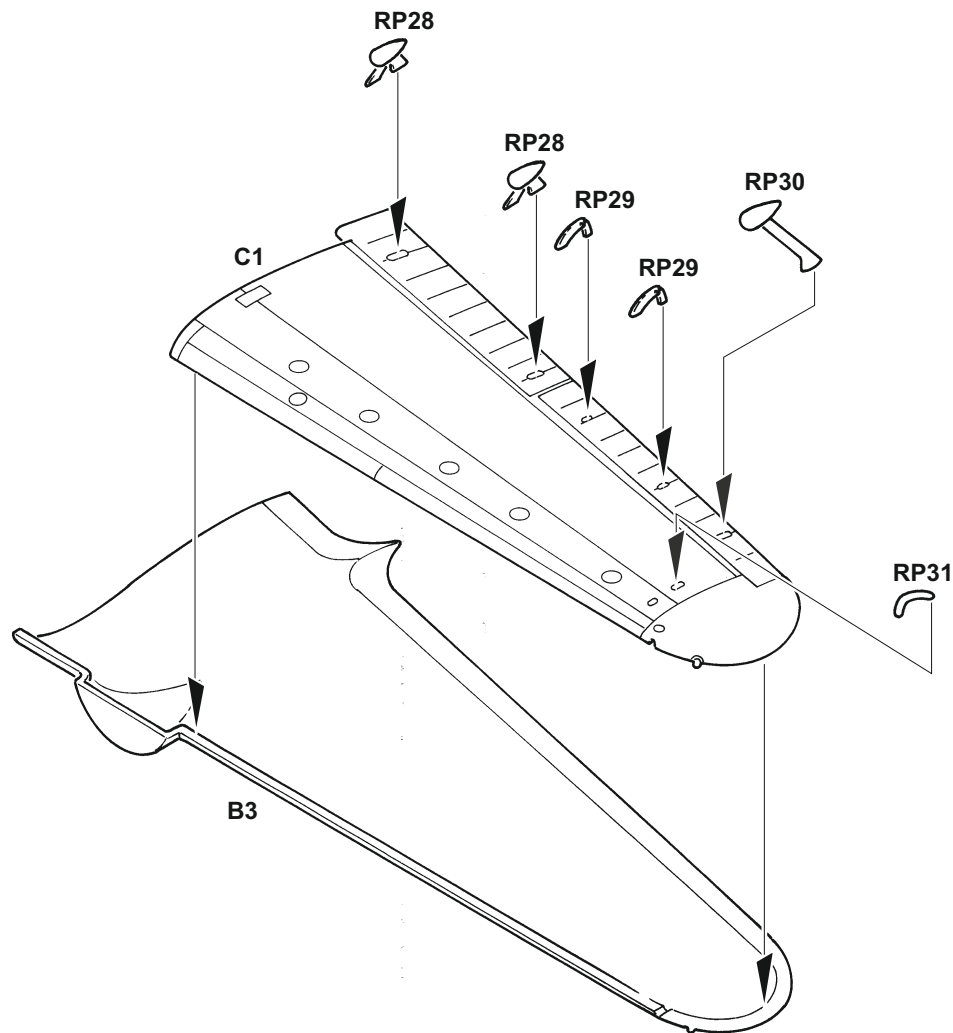
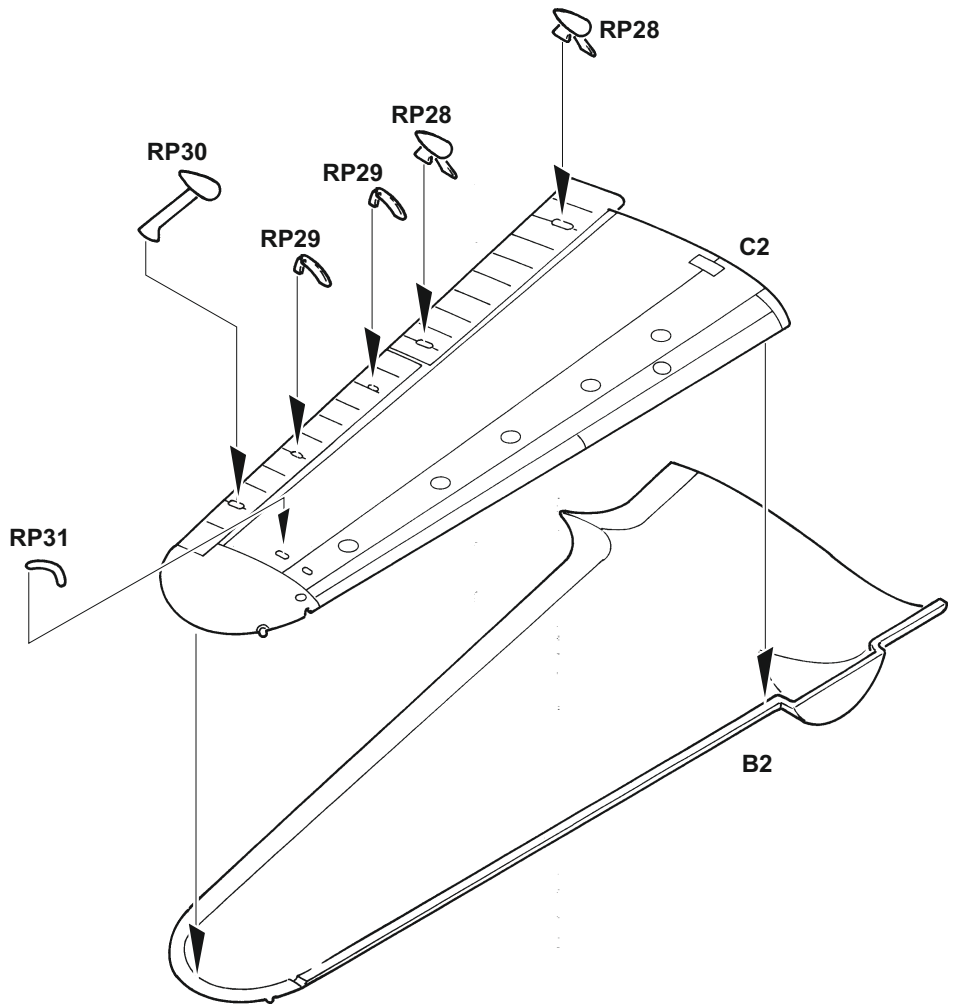

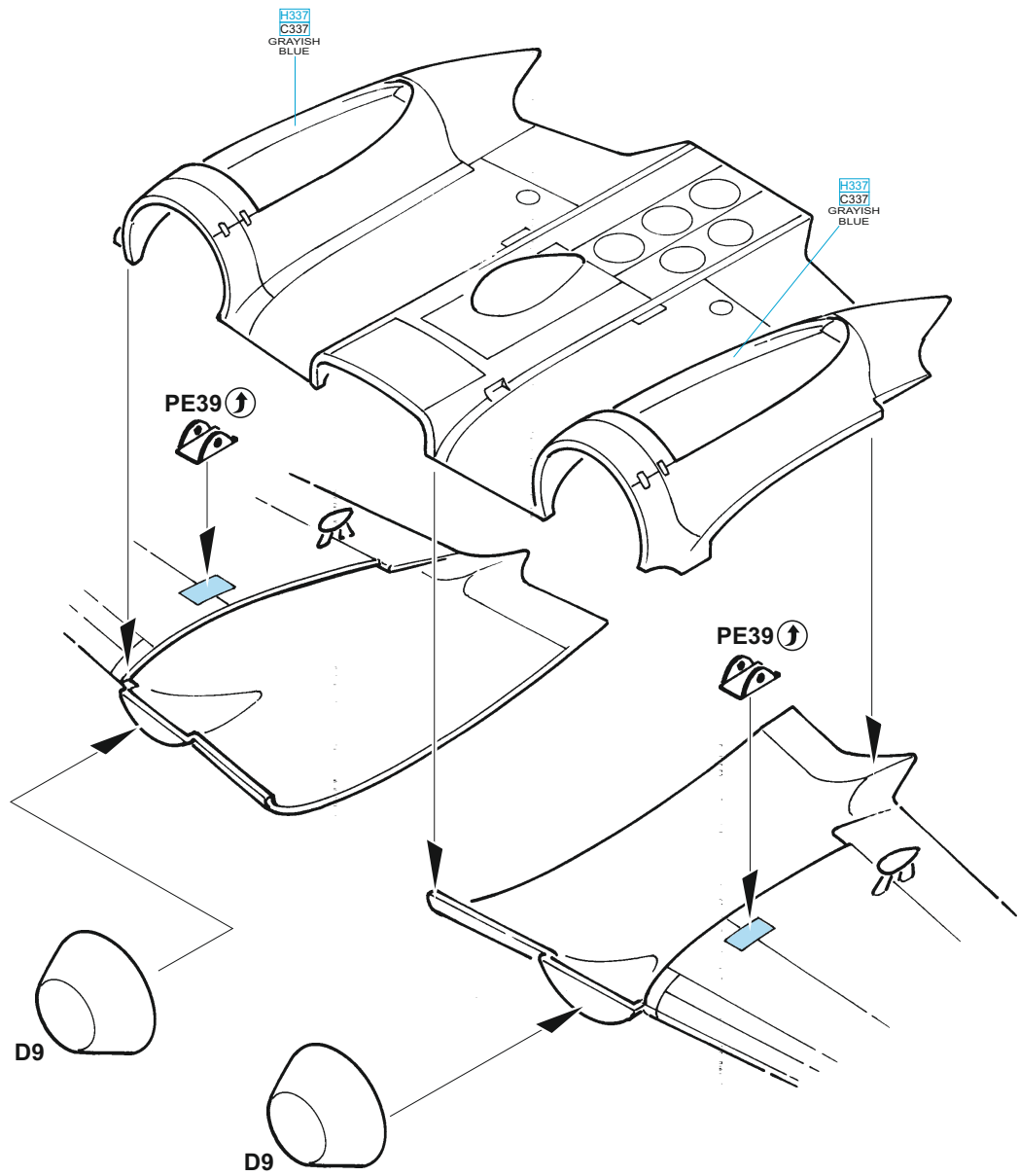
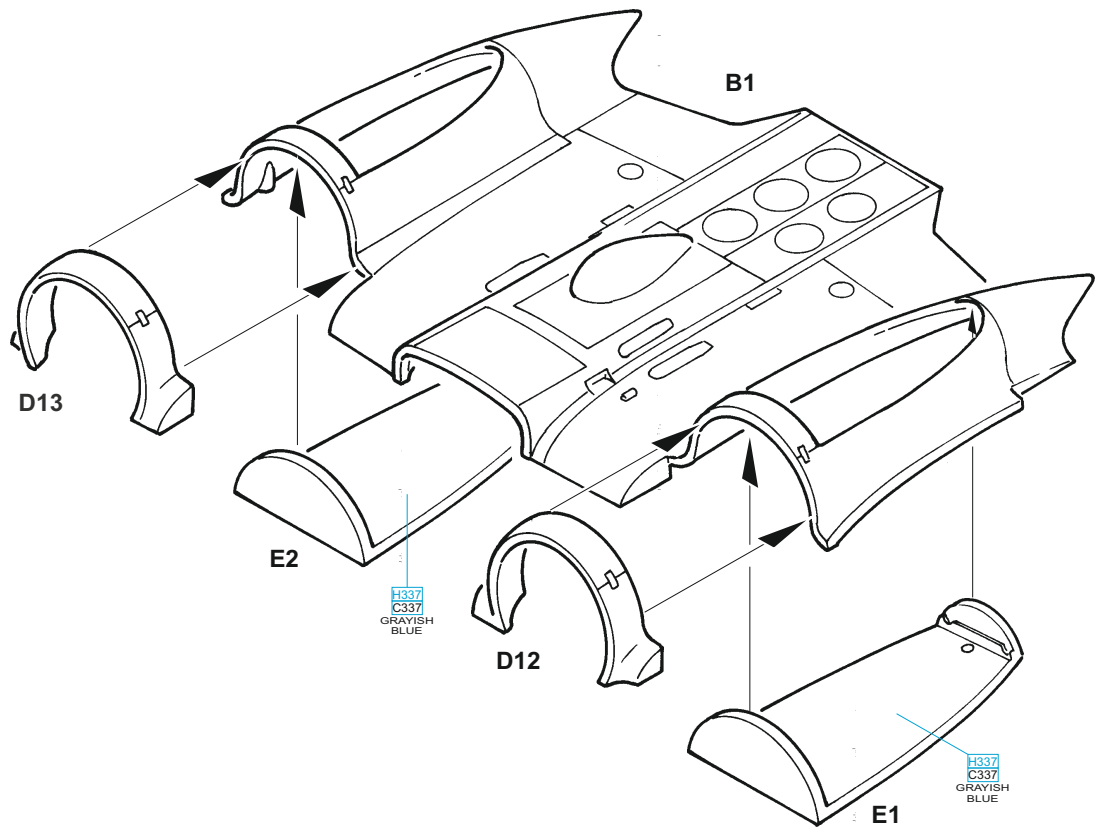

E

3 pcs.

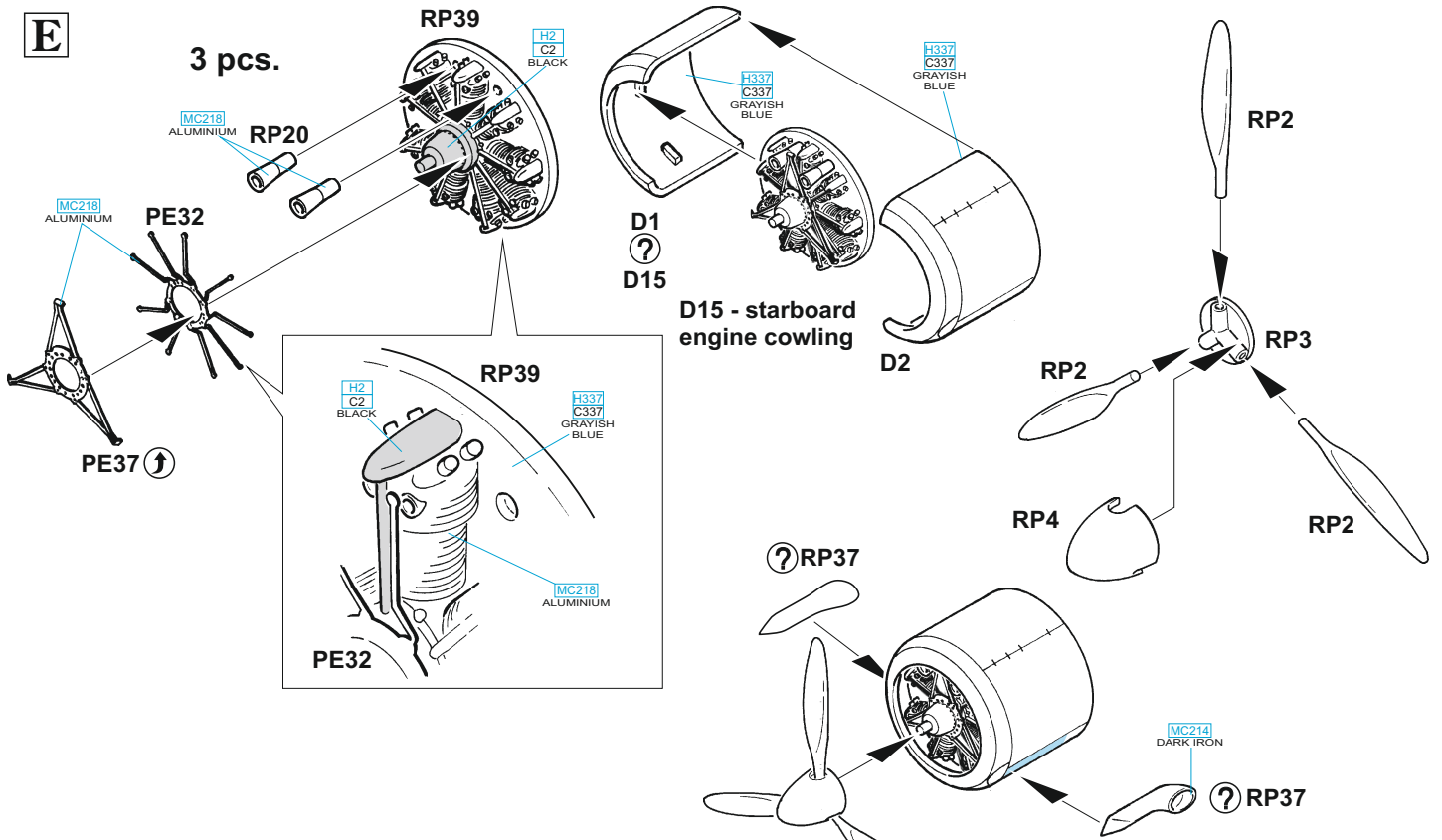

MARKINGS **A, C, D, E**

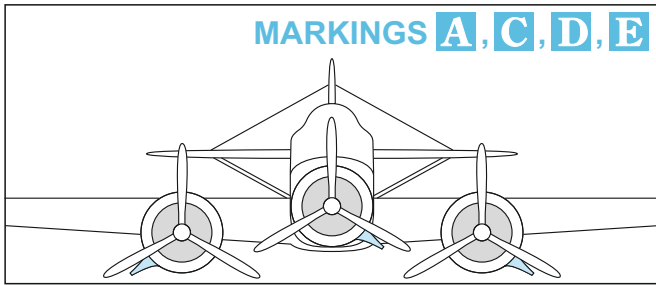

MARKINGS **B, F**

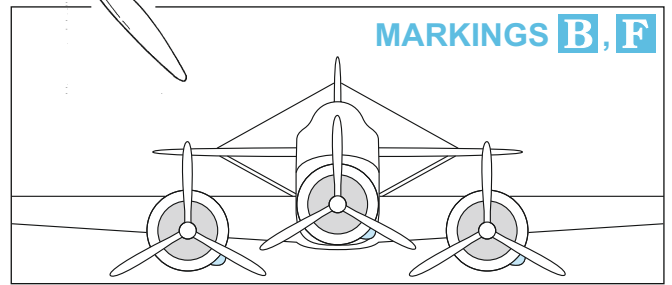

E6 - MARKINGS **B, F**

E11 - MARKINGS **A, C, D, E**

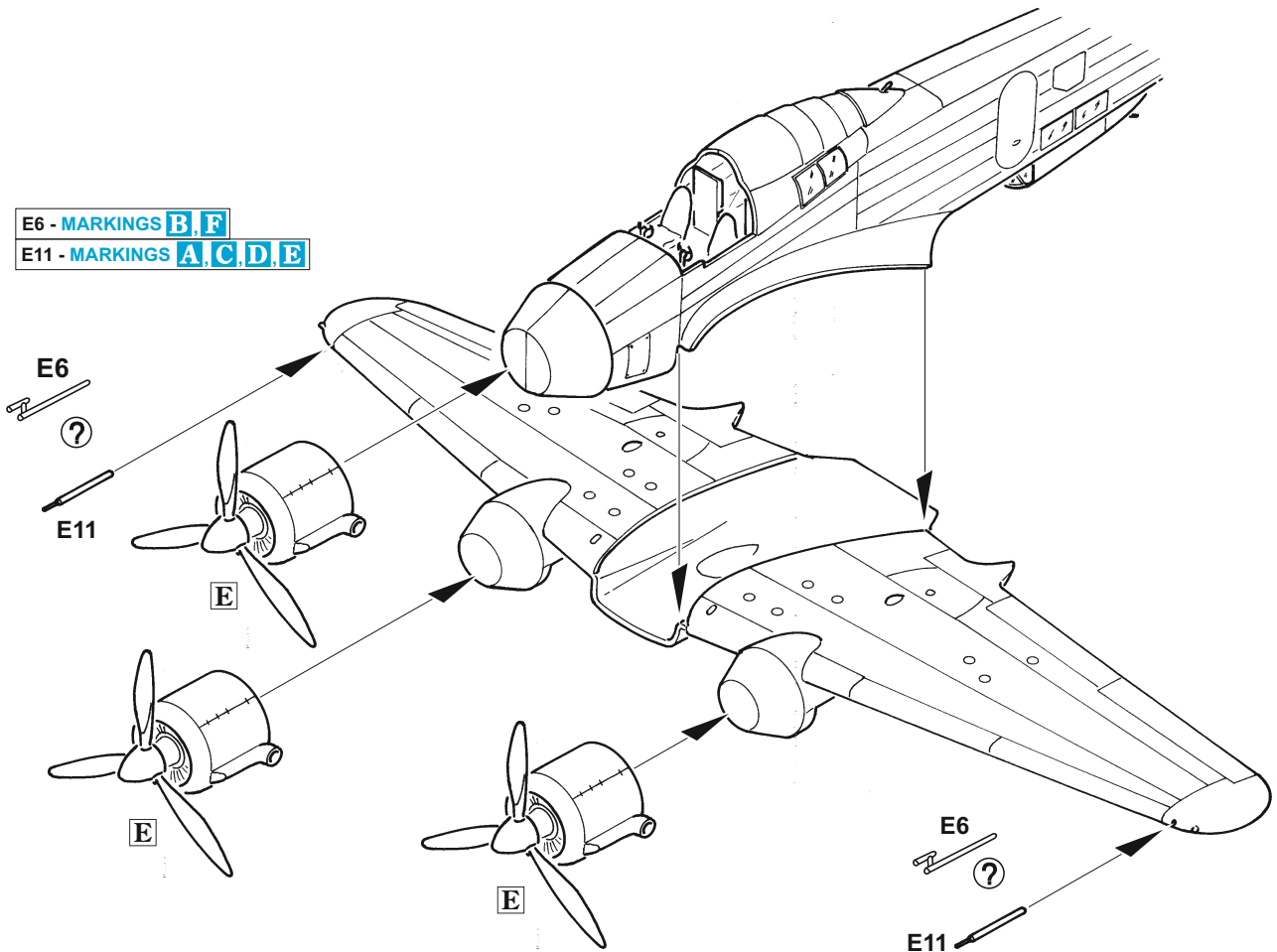

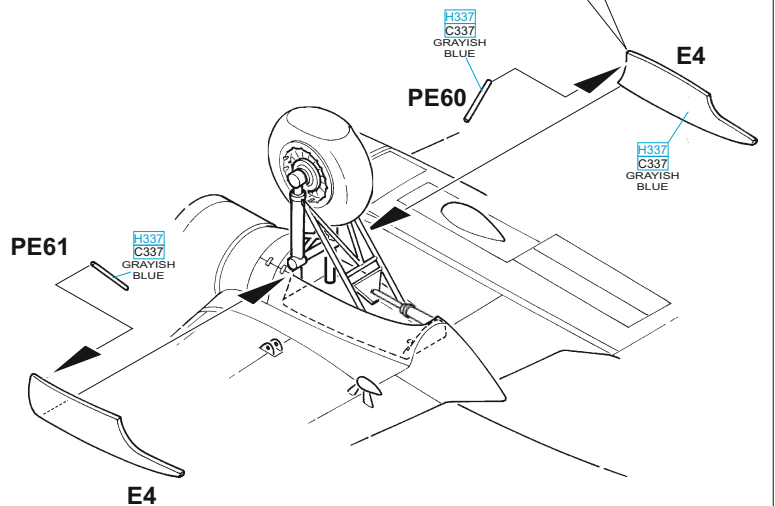
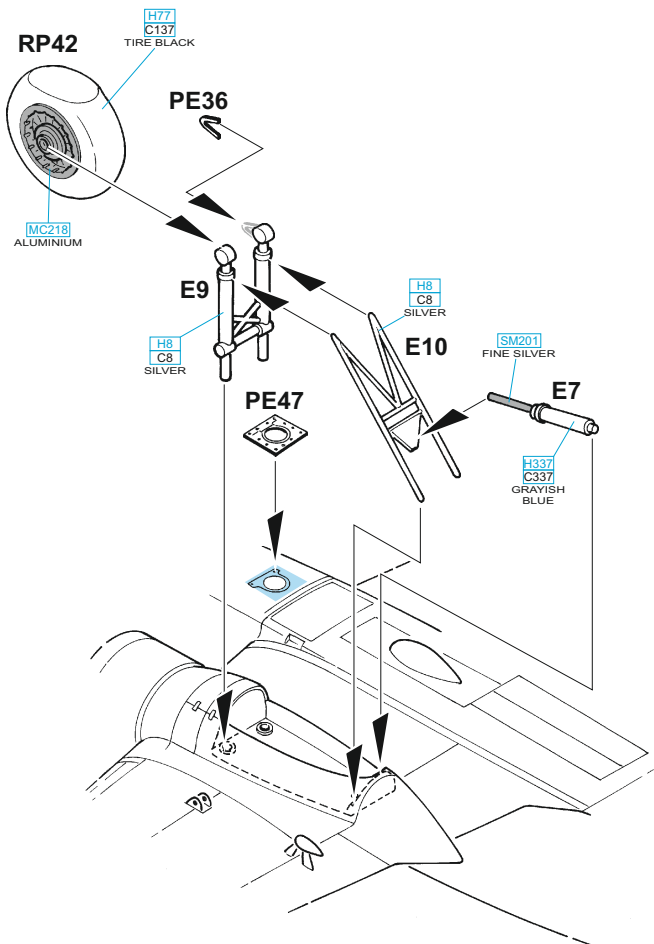
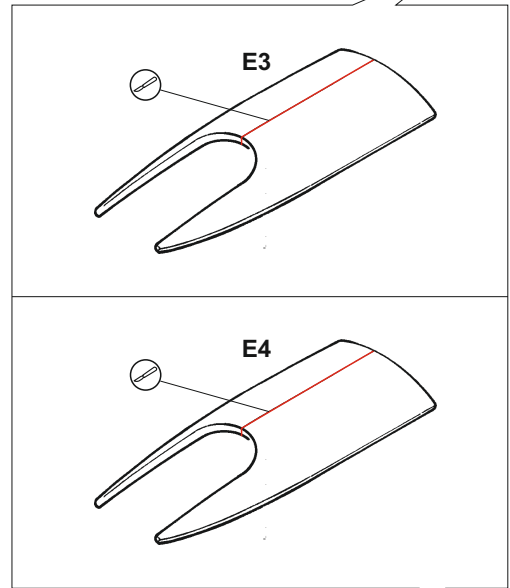
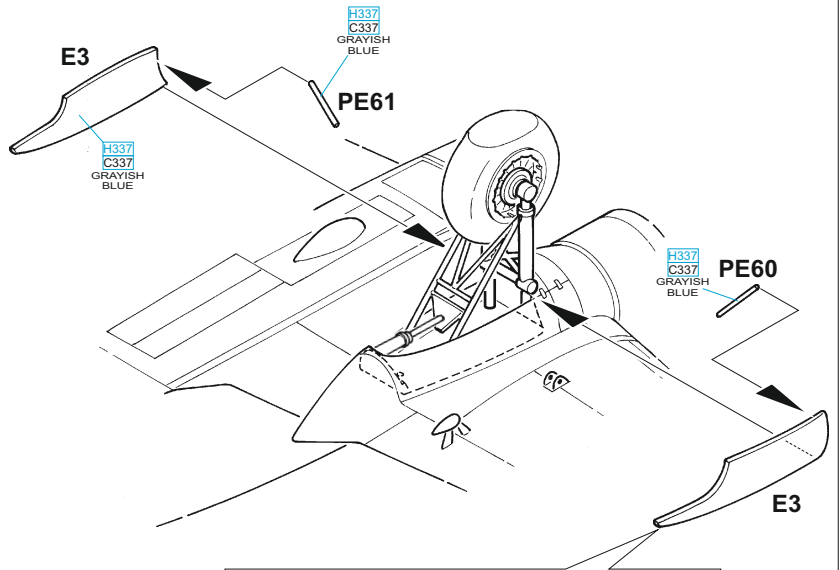
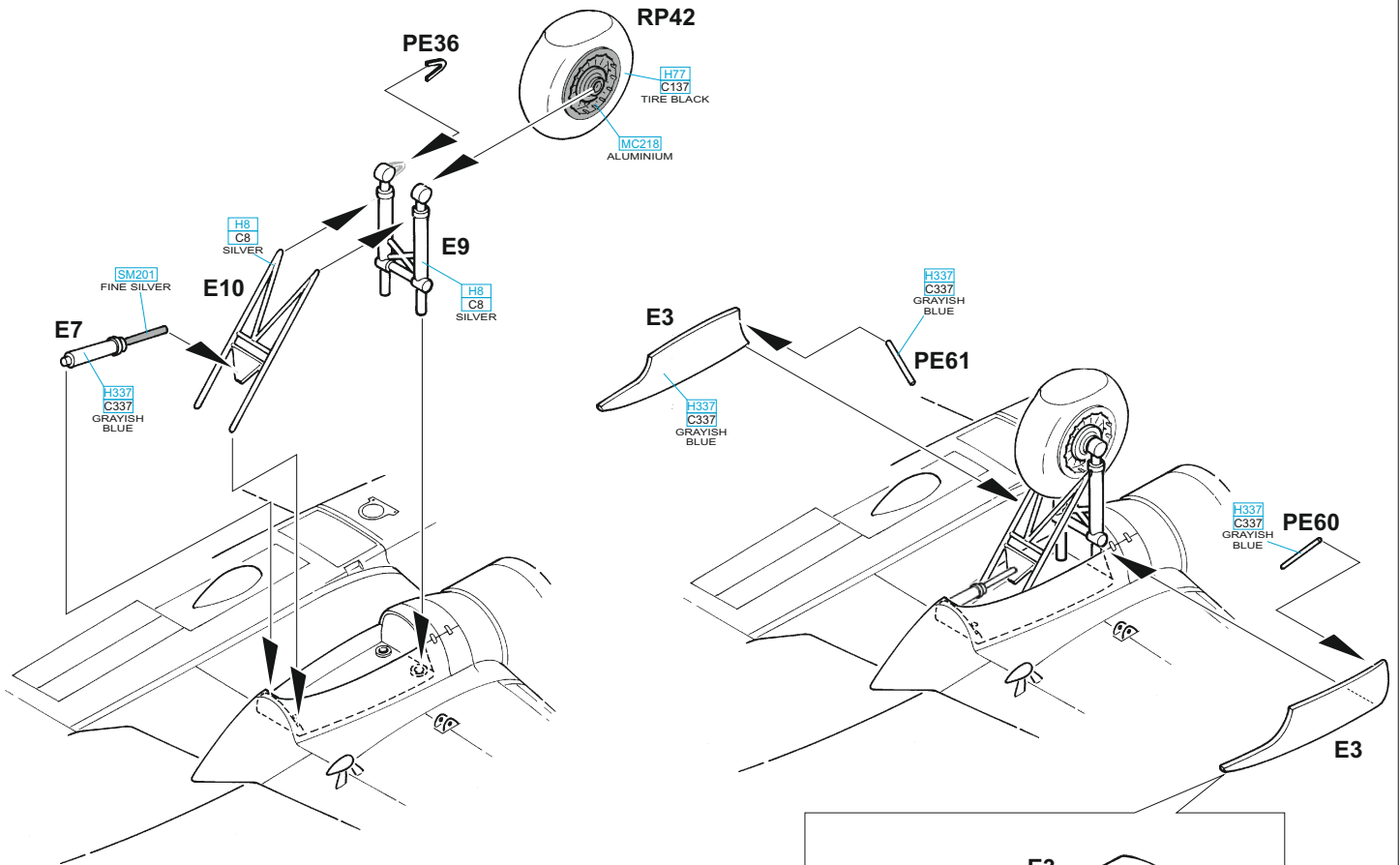

? MARKINGS A, E ONLY

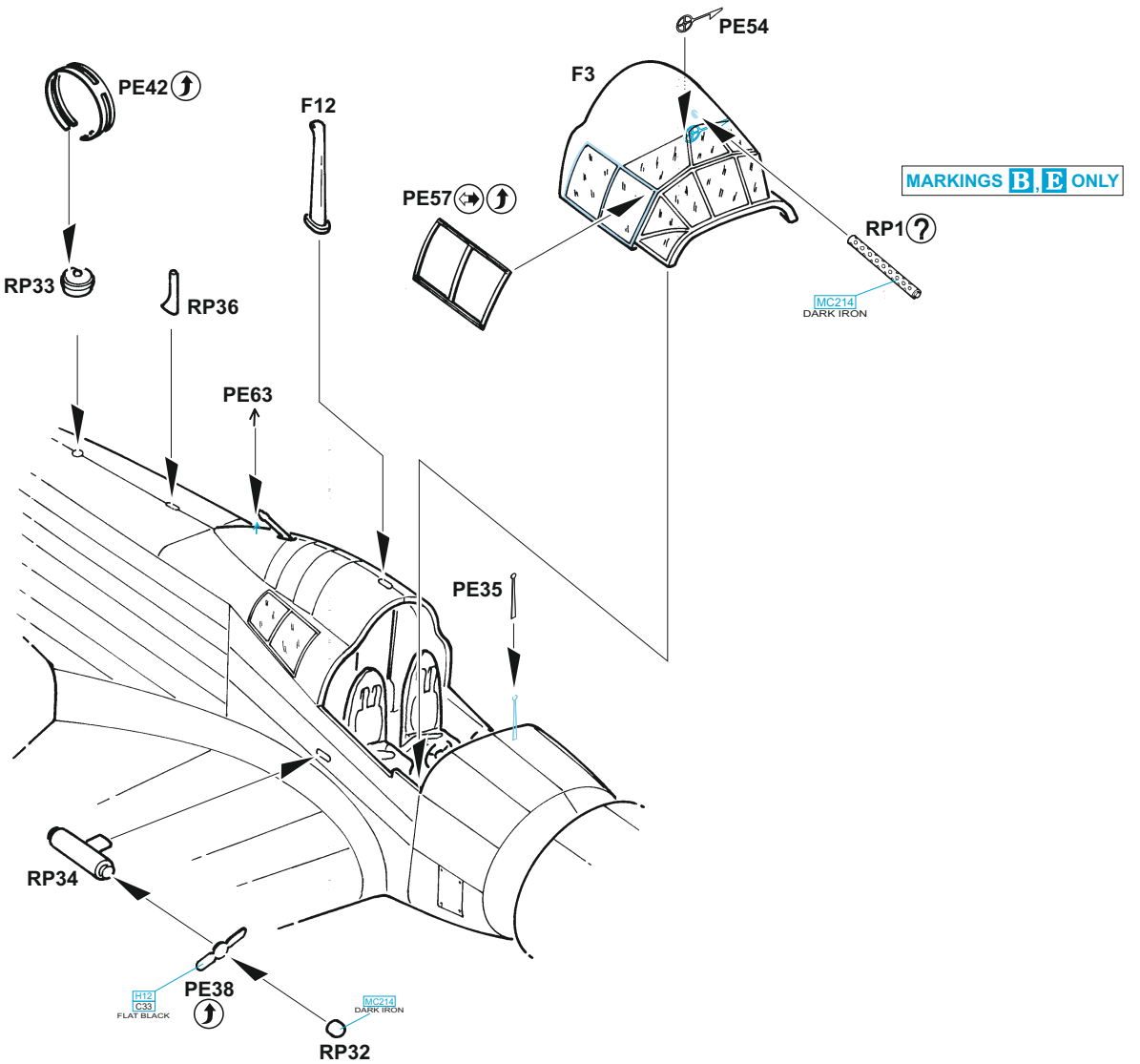
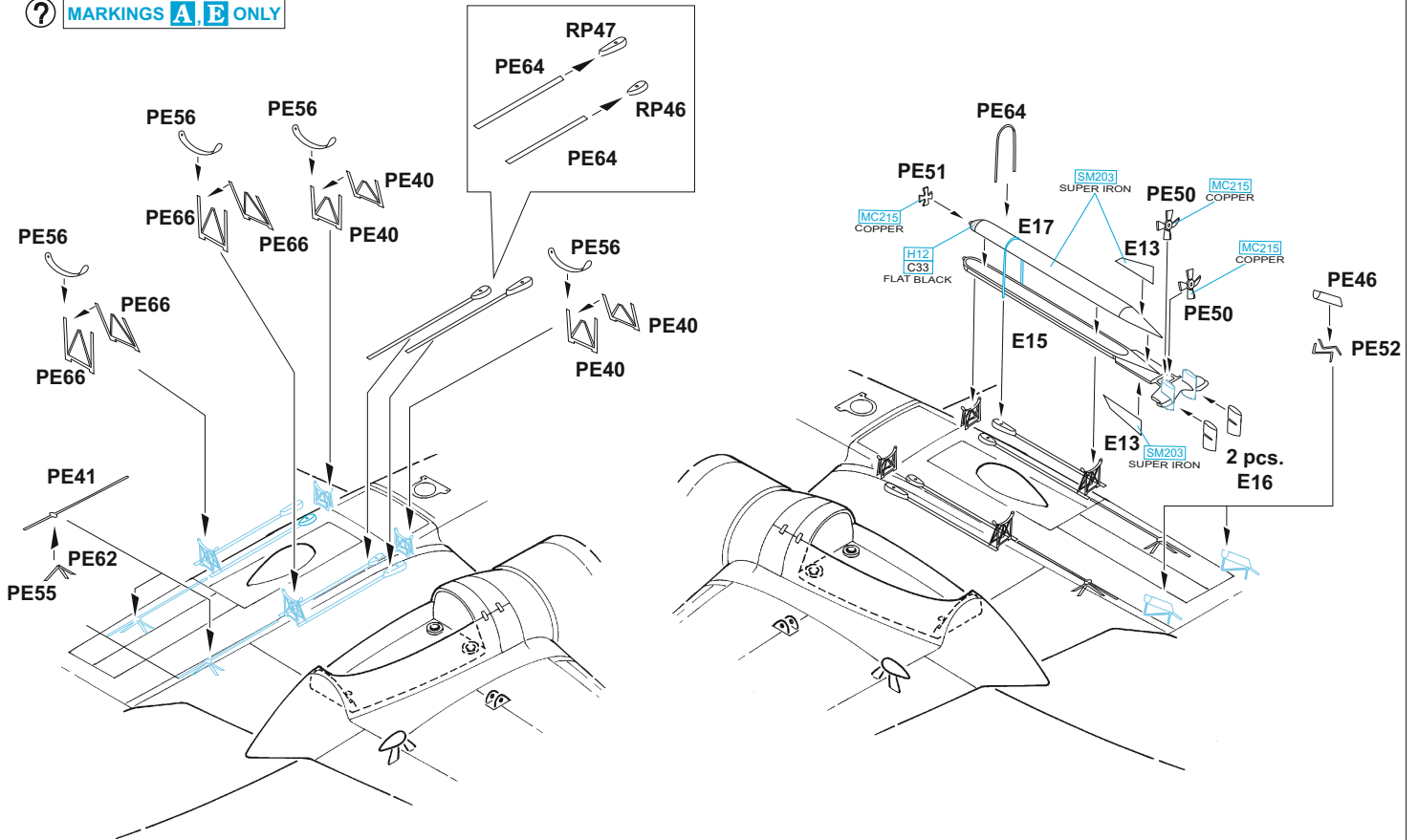

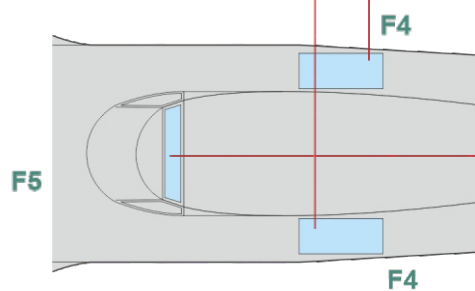
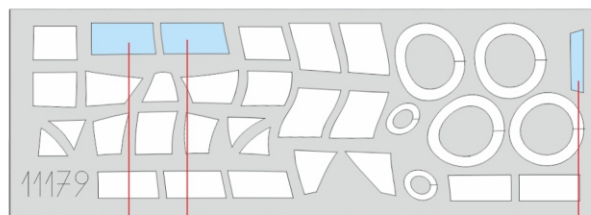
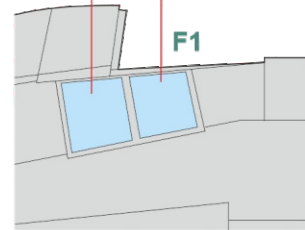
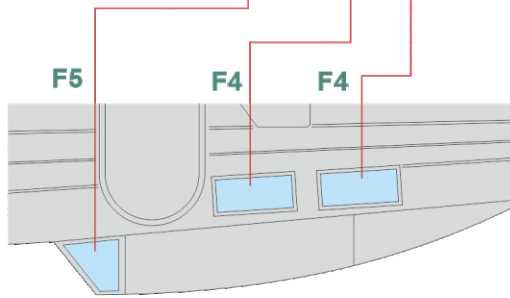
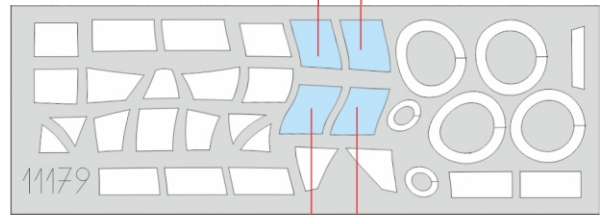
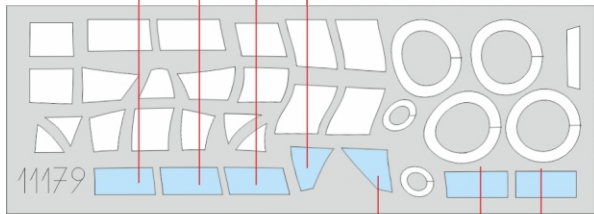
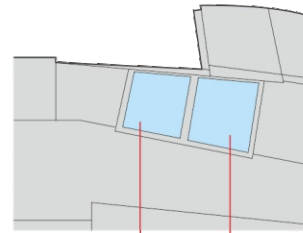
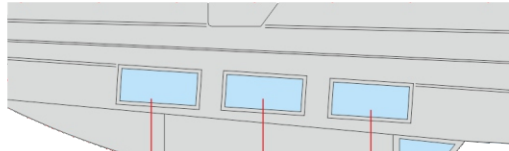
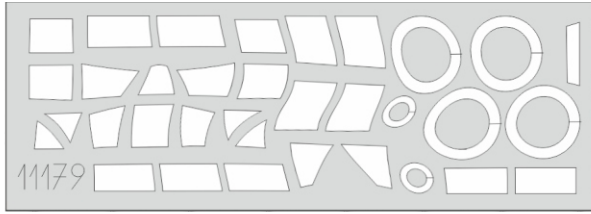

1.)

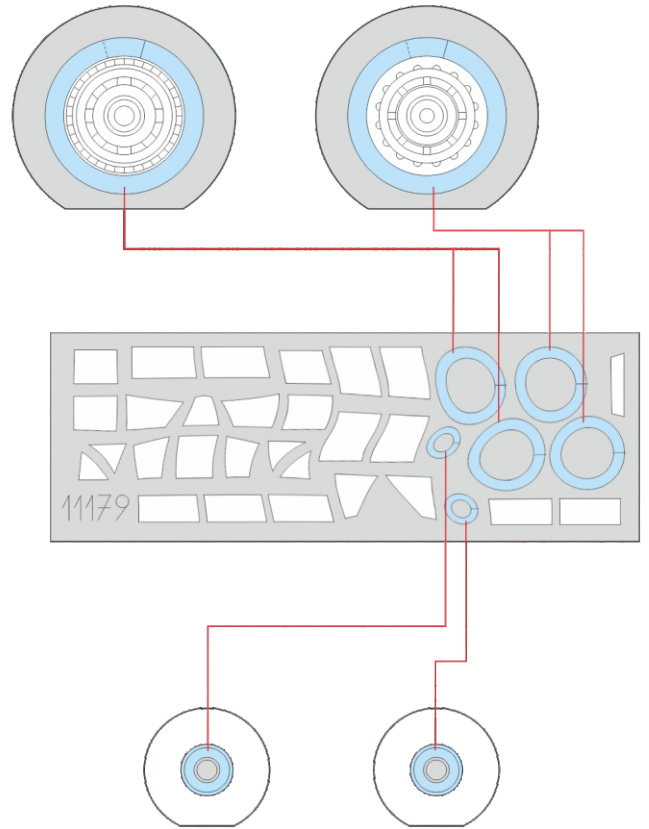
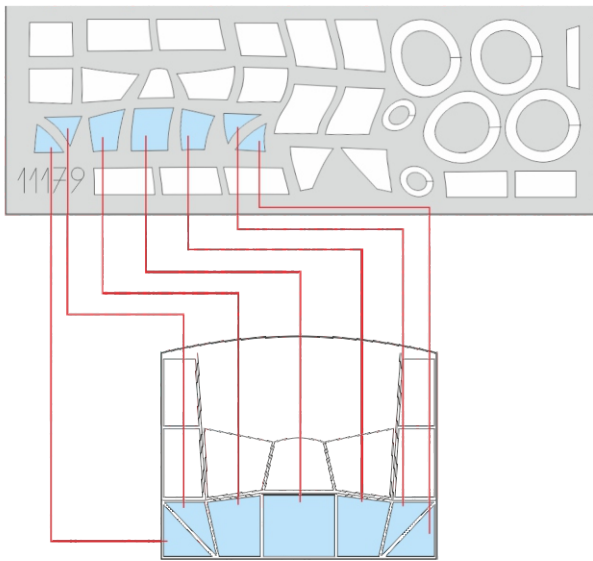

2.)

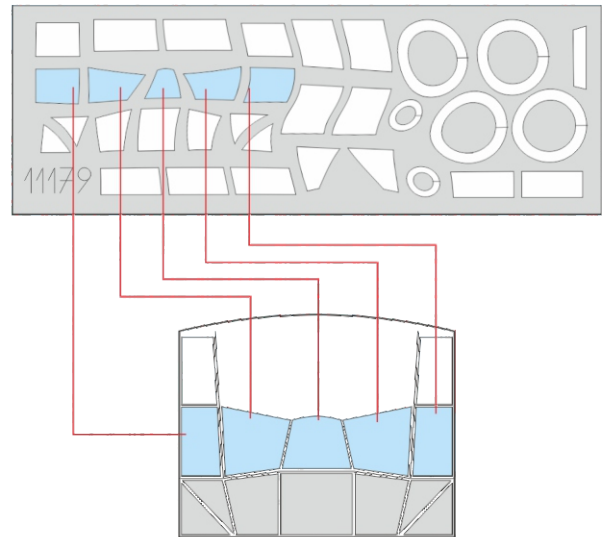

3.)

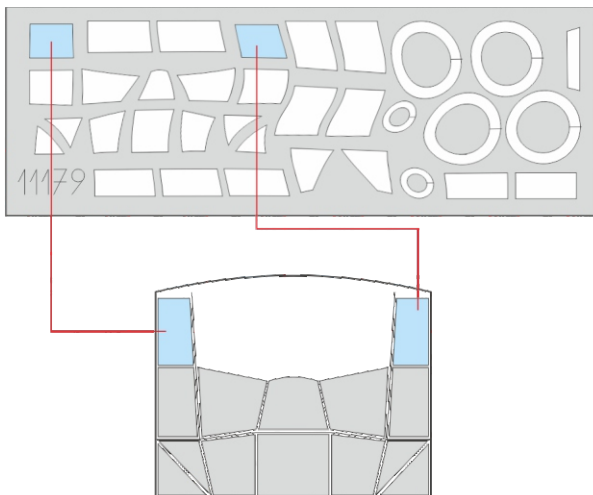

B 52^a Squadriglia, 27^o Gruppo BT, 8^o Stormo BV, Son San Juan, Baleares, March 1938

The first Sparvieros destined to support the Nationalists during the Spanish Civil War landed at Son San Juan airport in February 1937 and belonged to 12^o Stormo BV. The crews of this unit participated in actions against the Republicans until November 1937, when the 12^o Stormo pilots were replaced by colleagues from the 27^o Gruppo of the 8^o Stormo BV, known as the Falchi delle Baleari (Balearic Falcons). The Sparvieros, supplied from Italy, were painted in pre-war camouflage scheme, consisting of large color fields using the Marrone Mimetico 2, Verde Mimetico 1 and Giallo Mimetico 3 shades on the upper and side surfaces, while the lower surfaces were covered by Grigio Mimetico.

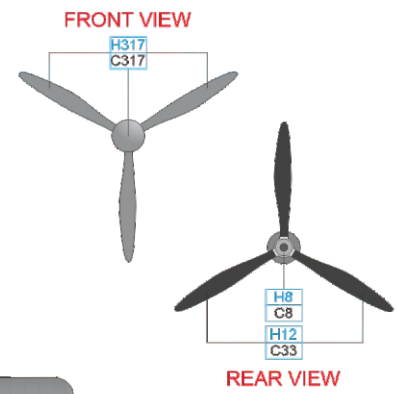
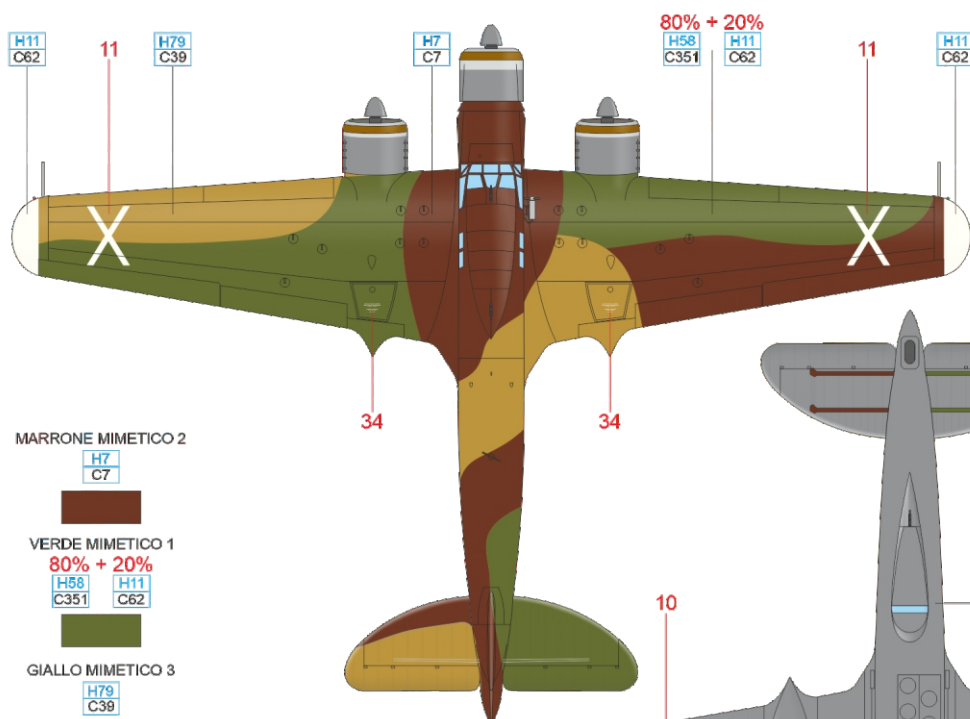
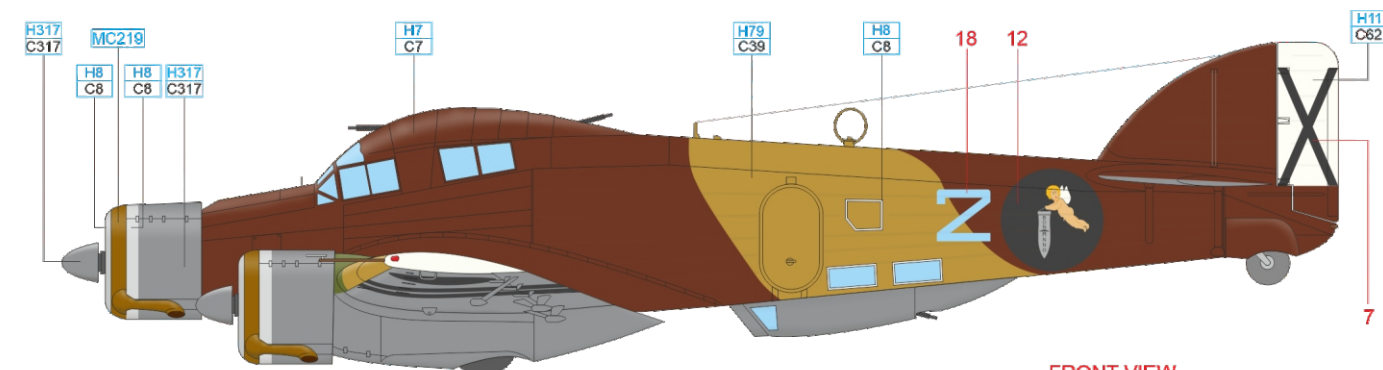

- MARRONE MIMETICO 2
H7
C7
- VERDE MIMETICO 1
 80% + 20%
H58
C351 H11
C62
- GIALLO MIMETICO 3
H79
C39

ČESKOU VERZI TEXTU NALEZNETE NA
www.eduard.com
 POD KATALOGOVÝM ČÍSLEM 11179

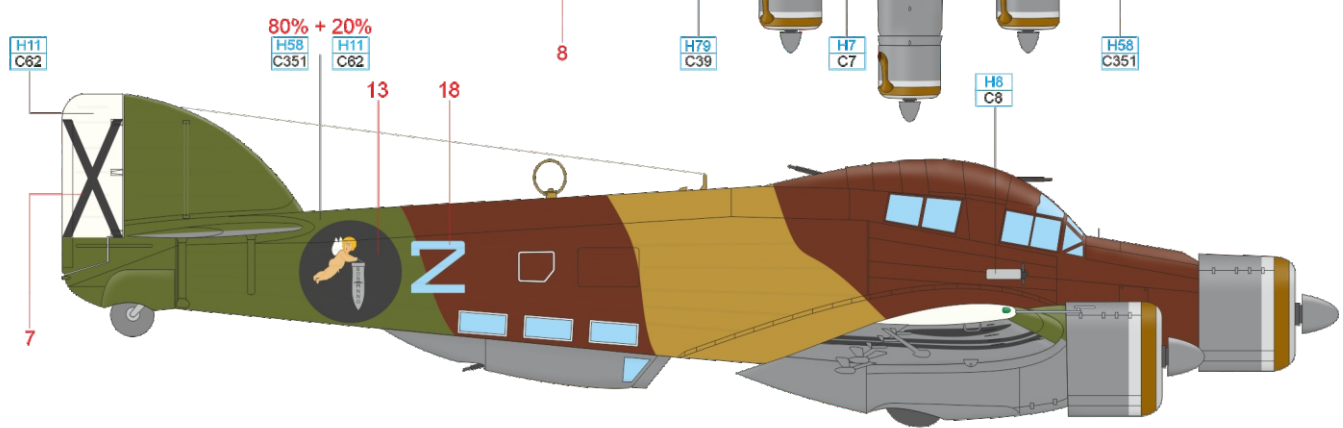
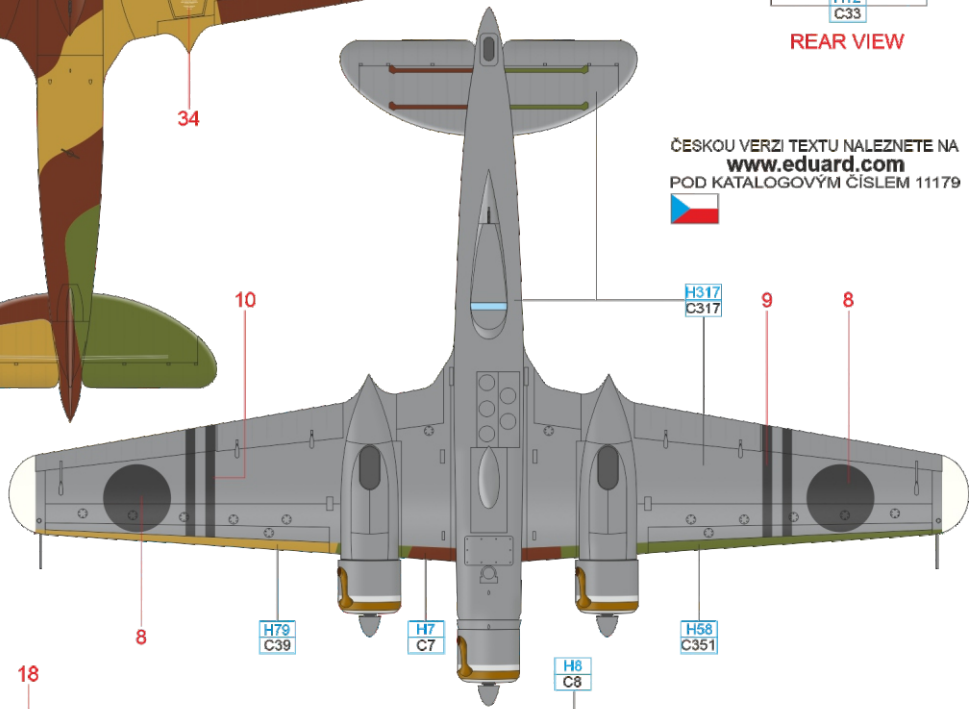

- SILVER H8
C8 BRASS MC219
- FLAT WHITE H11
C62 GRAY H317
C317 SANDY YELLOW H79
C39 INTERIOR GREEN H58
C351 BROWN H7
C7 FLAT BLACK H12
C33

The 192^a and 193^a Squadriglia, forming the 87^o Gruppo, received their first Sparvieros in 1938 and used them in Albania the following year. In early June, 1938 moved to Sciacca airfield in Sicily, from where its crews flew their first wartime missions against airfields in Tunisia. From June 6, Sparvieros of 193^a Squadriglia started raids on the island of Malta and on supplying convoys. The unit participated in the fighting against Malta until August 1941, when the rearmament of the unit to CANT Z.1007bis bombers began. The Sparviero, designated by the code 193-6, was camouflaged with Verde Mimetico 2, Marrone Mimetico 1 and Giallo Mimetico 2 on the upper and side surfaces, while the lower surfaces were sprayed with aluminum paint. The unit's emblem – Omino Elettrico – was painted on the fuselage sides, and the canvas punctures sustained during the Malta raids were covered with patches. It is not entirely clear whether these took the form of British or Italian cockades. The larger punctures were re-taped with pieces of canvas with the Italian tricolor and a label indicating when the damage occurred. Under the fuselage codes was the inscription CHI-MI-TOCCO-CI-LASCIO-LE-PENNE.

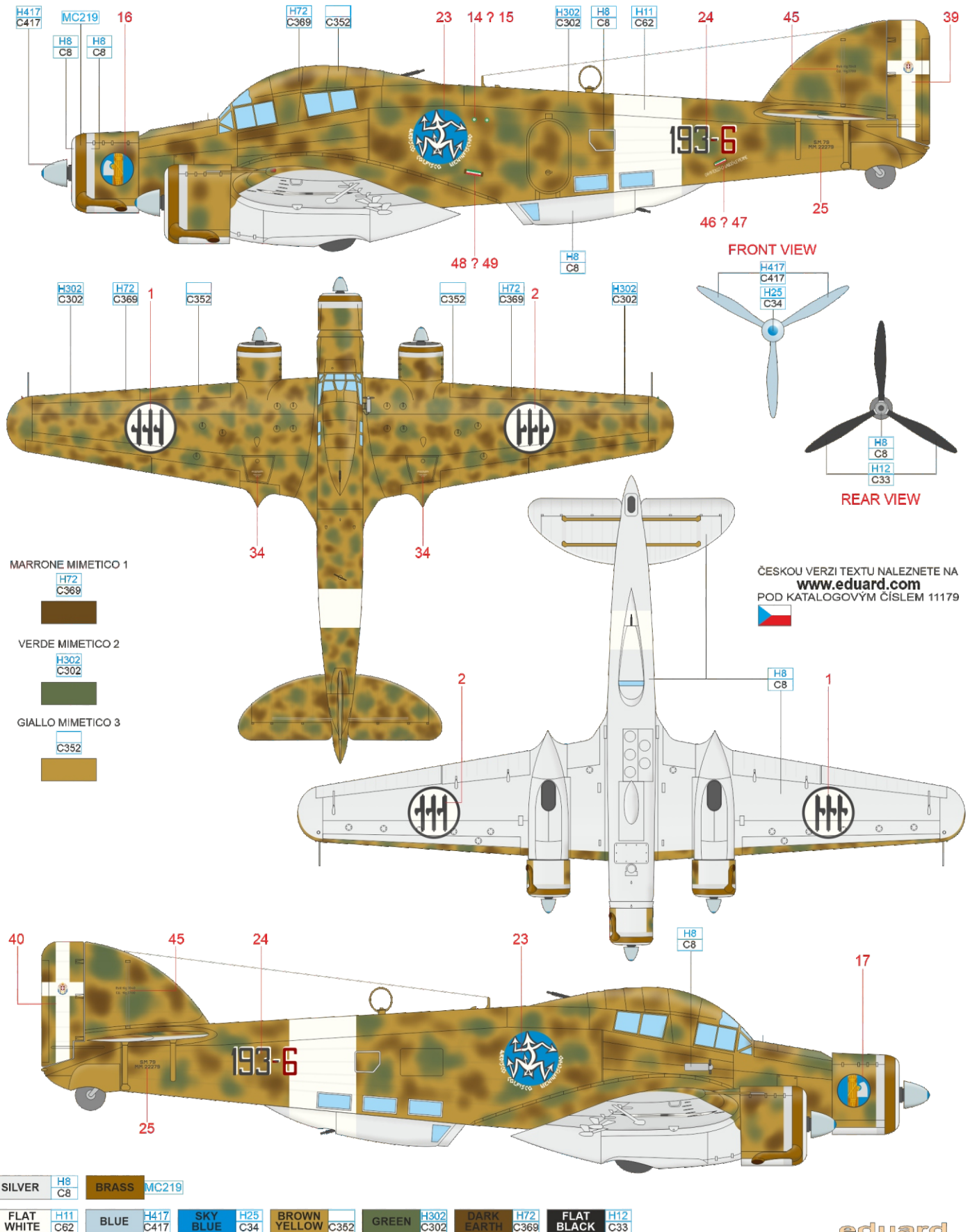

D MM 22593, 252^a Squadriglia, 104^o Gruppo BT, 46^o Stormo, Skadar, Albania, end of 1940

The 252^a Squadriglia, which was formed together with 253^a Squadriglia, 104^o Gruppo BT, received the first Sparviero on February 15, 1940. In June of the same year the crews took part in the first raids on targets in Corsica and Marseilles, followed by a move to an airfield in occupied Albania in November, from where the Sparviero took off for bombing raids over Greece. The Sparviero used by 252^a Squadriglia were camouflaged in several camouflage schemes, consisting of both spots and irregular patches. The Sparviero with number 252-3 had the camouflage of irregular patches sprayed with Marrone Mimetico 53193, Verde Mimetico 53192 and Giallo Mimetico 3 shades on the upper and side surfaces, the lower surfaces were sprayed with aluminum paint.

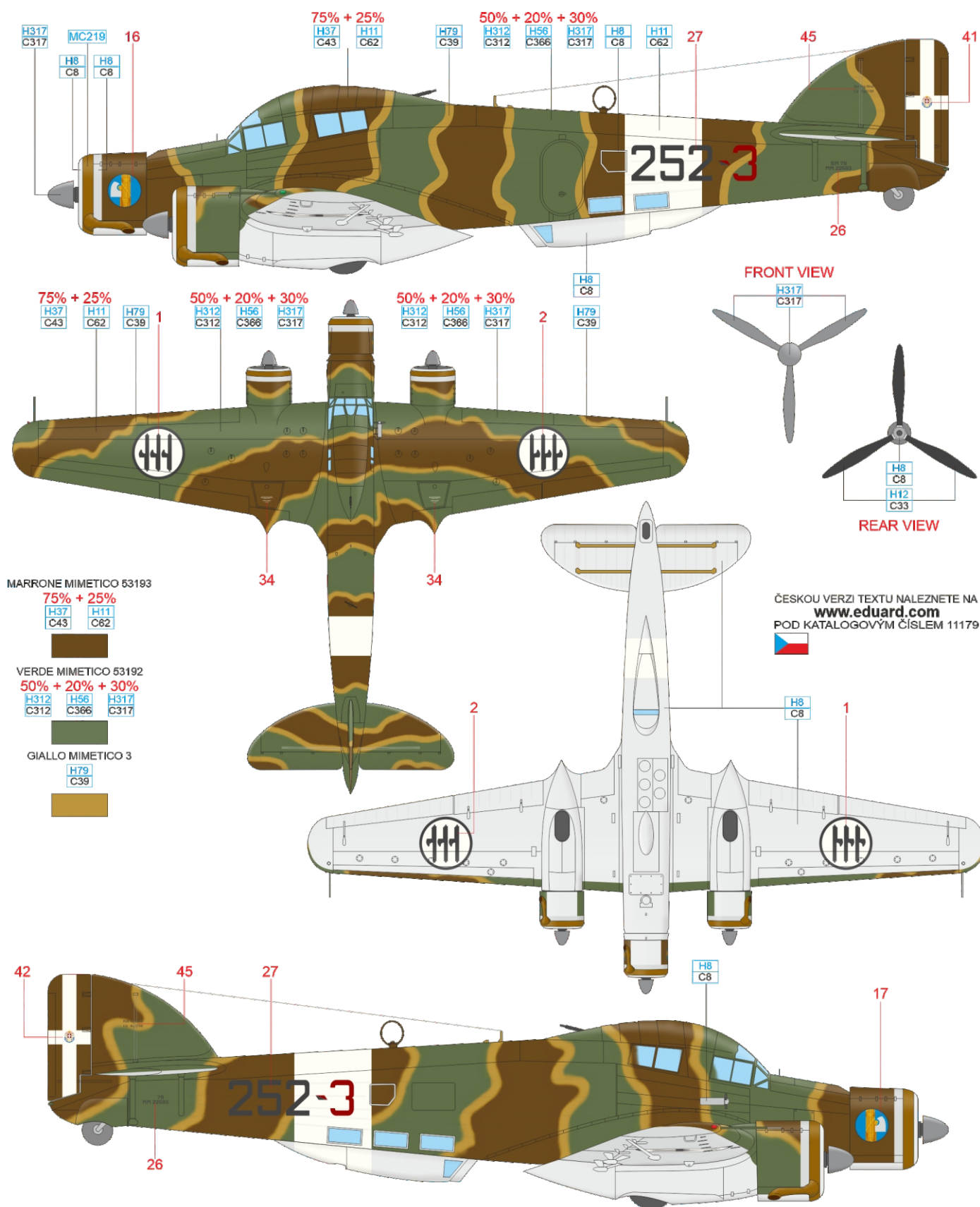

MARRONE MIMETICO 53193

75% + 25%
H37 C43 H11 C62

VERDE MIMETICO 53192

50% + 20% + 30%
H312 C312 H56 C366 H317 C317

GIALLO MIMETICO 3

H79 C39

ČESKOU VERZI TEXTU NALEZNETE NA
www.eduard.com
POD KATALOGOVÝM ČÍSLEM 11179



SILVER H8 C8 BRASS MC219

FLAT WHITE H11 C62 GRAY H317 C317 INTERMEDIATE BLUE H56 C366 GREEN H312 C312 SANDY YELLOW H79 C39 BROWN H37 C43 FLAT BLACK H12 C33

eduard

E 253ª Squadriglia, 104º Gruppo BT, 46º Stormo, Gadurra, Rhodes, August 1942

The crews of 104º Gruppo Sparvieros were retrained for anti-ship torpedo attacks in the spring of 1942, and the unit first moved to Decimomanu airfield on the island of Sardinia in May 1942 to conduct raids on ships of the Harpoon convoy. Later they moved to Rhodes in July, from where they undertook reconnaissance flights over the eastern Mediterranean and attacks against Allied shipping in the same area. The Sparvieros used by 252ª Sq. and 253ª Sq. against ships in the summer of 1942 were camouflaged with Verde Oliva Scuro 2 shade on the upper and side surfaces, the lower surfaces were painted in Grigio Azzuro Chiaro 1 shade. The olive color on upper surfaces was supplemented with irregular patches of GAC 1 paint before Rhodes deployment. The vertical fin of the aircraft number 253-8 was like the other aircraft of the unit adorned by silhouettes of the ships, which were hit during the operation against the Harpoon convoy by the entire 104º Gruppo BT.

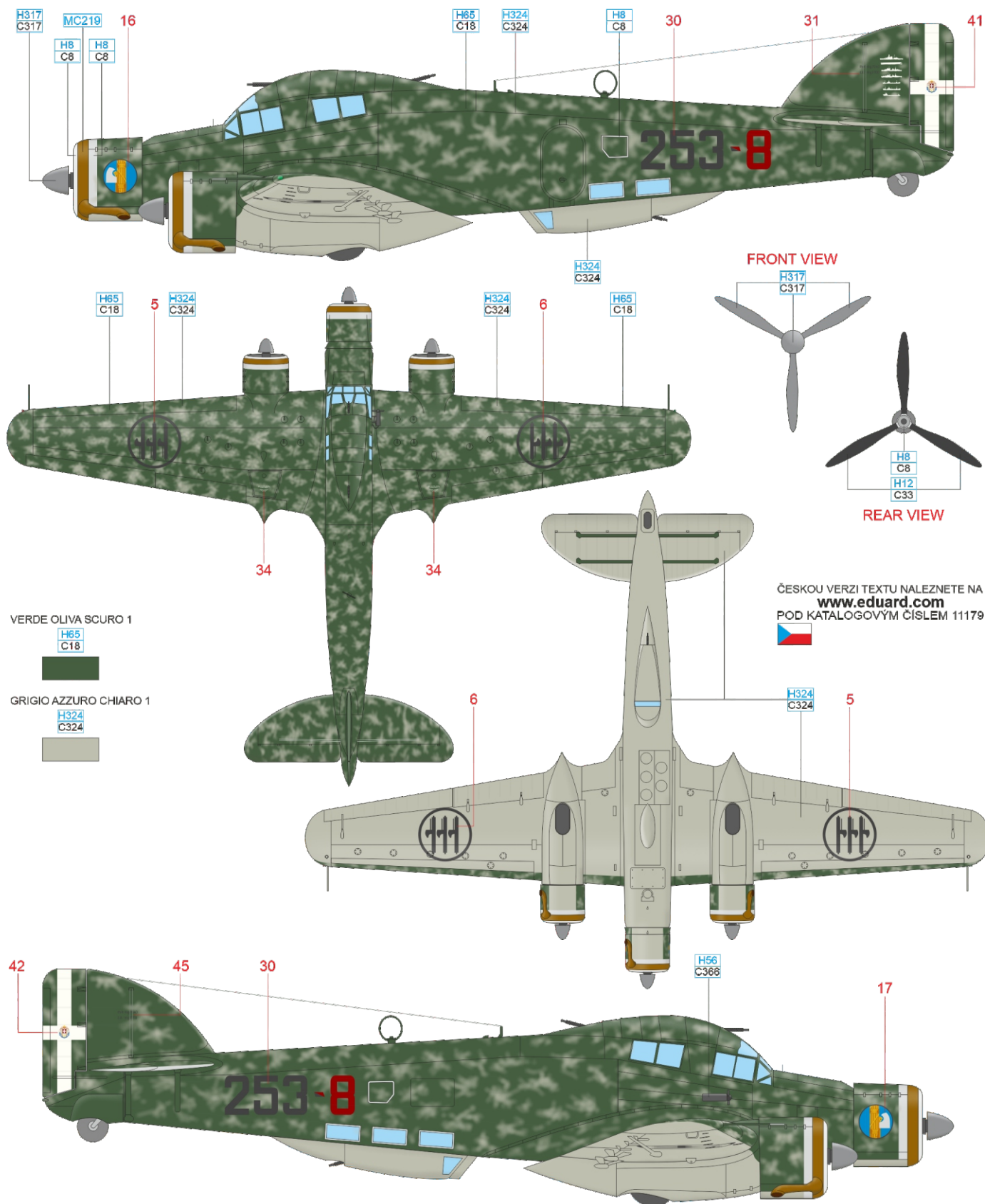

VERDE OLIVA SCURO 1
H65
C18

GRIGIO AZZURO CHIARO 1
H324
C324

ČESKOU VERZI TEXTU NALEZNETE NA
www.eduard.com
 POD KATALOGOVÝM ČÍSLEM 11179

SILVER H8
C8 BRASS MC219

GRAY H317
C317 LIGHT GRAY H324
C324 GREEN H65
C18 FLAT BLACK H12
C33

F 256ª Squadriglia, 109º Gruppo BT, 36º Stormo, Castelvetro, Sicily, June 1940

The entire 109º Gruppo, consisting of 256ª Squadriglia and 257ª Squadriglia, was formed along with its sister 108º Gruppo in the spring of 1938 at Bologna Borgo Panigale airfield. These units were equipped with Savoia SM.79s and SM.81s and took part in the occupation of Albania with them. Subsequently, they were moved back to Sicily, from where they undertook raids on Malta and on convoys transporting much needed material destined for the struggling island and its inhabitants. The camouflage of this Sparviero consisted of a base color of Giallo Mimetico 3 on the upper and side surfaces, with irregular patches of Marrone Mimetico 53193 and Verde Mimetico 53192 shades. The lower surfaces were camouflaged with Grigio Mimetico. On both sides of the vertical fin, there was painted the emblem of 36º Stormo, the towers of Asinelli and Garisenda, monuments and landmarks of the city of Bologna, meant as a honor of the place of origin of this unit.

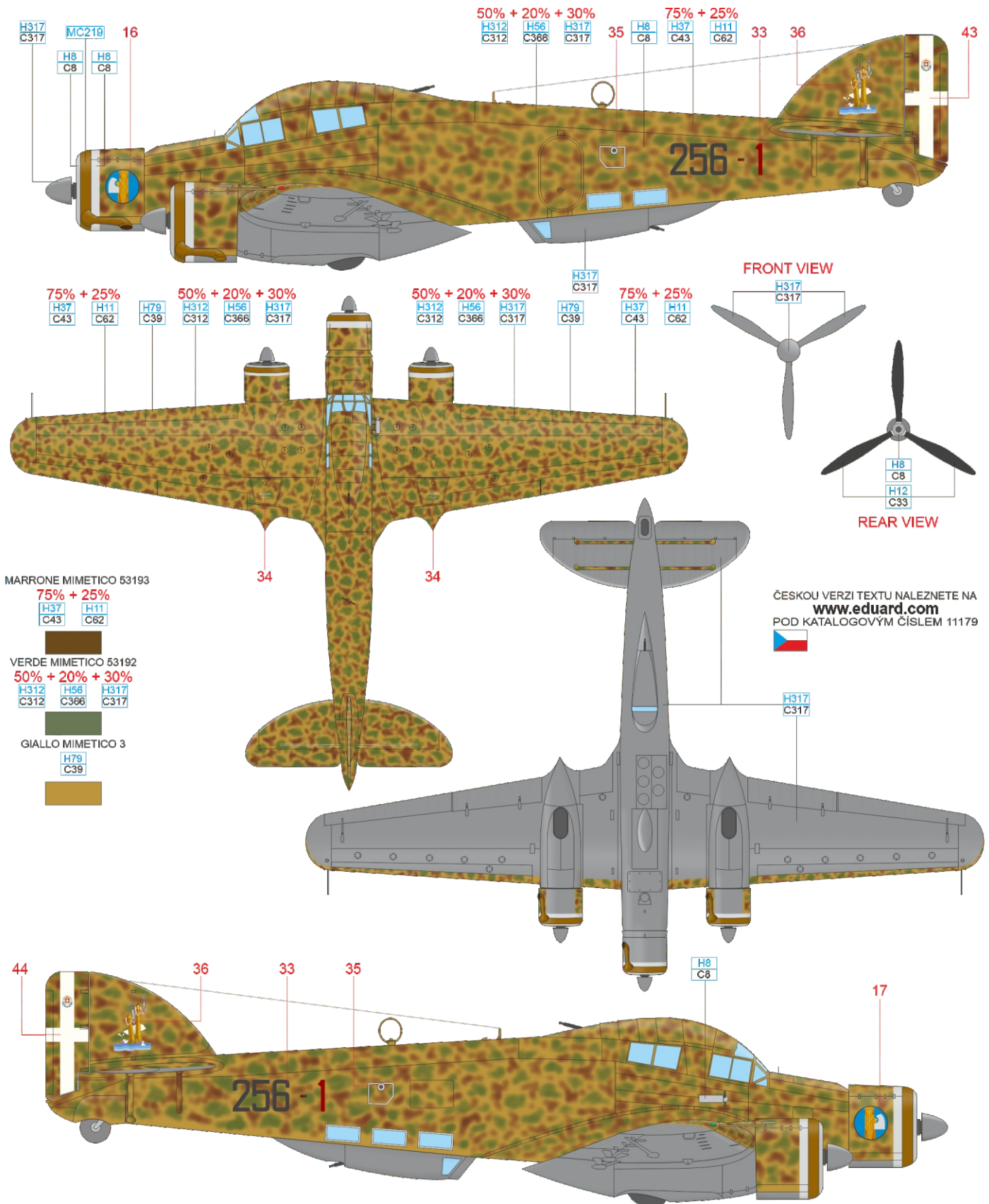

SILVER H8 C8 BRASS MC219

FLAT WHITE H11 C62 GRAY H317 C317 INTERMEDIATE BLUE H56 C366 SANDY YELLOW H79 C39 WOOD BROWN H37 C43 GREEN H312 C312 FLAT BLACK H12 C33

eduard