

# Schwerer Zugkraftwagen 18 t Sd.Kfz.9 Artillery Version

Sd.Kfz.9 18吨半履带炮兵运输型

## READ BEFORE ASSEMBLY:

- Study and understand these instructions thoroughly before beginning assembly
- When needed, remove photo-etch parts carefully using a modeling knife or photo etch sprue cutter, being careful not to damage or lose small parts.
- Take extra care in handling photo etch parts in order to avoid injury
- Apply instant cement sparingly to photo etch parts where instructed
- Tools recommended(not included in kit):Plastic and instant cements, sprue cutters, long nose pliers, modeling knife, small files, tweezers, pin vise & scissors. Soft cloth and sandpaper will also assist in construction
- Glue and paint are not included in the kit. Use plastic cement and hobby paints only. Color guide for purchasing paint is included in the kit.

## 装配之前仔细阅读

- 小心用模型锉刀锉平所有零件表面的注射浇口。
- 小心用刀片切下蚀刻片零件，不要遗失小零件。
- 用强力快干胶水粘合蚀刻片零件和金属轴。过量快干胶水使用可能导致可动零件会粘住，小心涂胶。
- 取蚀刻片时应特别注意安全，防止利边划伤手指。
- 某些零件表面需贴上水贴纸，请选择在装配的同时进行。
- 推荐模型工具(自备)：胶水，水口剪刀，长咀钳，刀片，锉刀，镊子，钳，钻，剪刀，瞬间快干胶。
- 软布同砂纸同时也是所需工具。
- 请使用塑料胶水和油漆，模型内不含。



使用强力胶  
Cyanoacrylate glue



配重  
Weight



钻孔  
Make hole



切除  
Cut / Remove



贴纸  
Decal



锉平  
File / Sand



选择  
Option



不涂胶水  
No cement



弯曲  
Bend



先装  
Install it first



填补  
Repair

## 水贴纸的使用:

- 1.从水贴上剪下印花;
- 2.将印花放入温水中浸10秒, 然后放在干净布上。
- 3.拿着印花纸板将印花移到模型上;
- 4.手指蘸水将印花移到适当的位置;
- 5.用软布轻压印花直至水干, 汽泡消失

## DECAL APPLICATION

- 1.Cut decals from sheet as needed
- 2.Dip the decal in warm water for about 10 seconds and then place on soft clean cloth.
- 3.Hold the decal backing sheet edge and gently slide the decal onto the model in its proper position.

- 4.While still wet,decal can be adjusted for better fit on model by dampening it gently with your finger.
- 5.When placed in the proper position,gently press decal down with a soft cloth until excess water and air bubbles are gone.
- 6.Allow decal to dry completely before handling model

\* 说明书中含有重要信息, 应保留。 Please Keep instruction since it contains important information.

部品图 Parts

Ax2

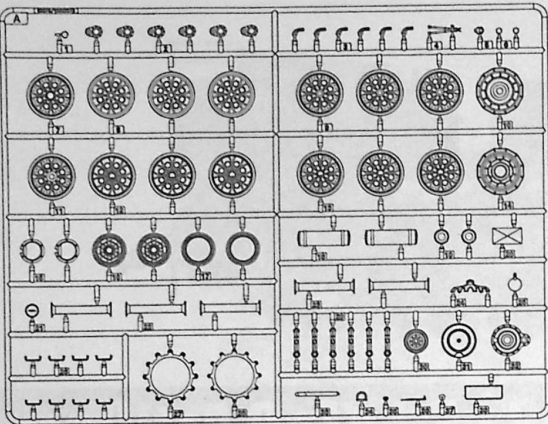

B

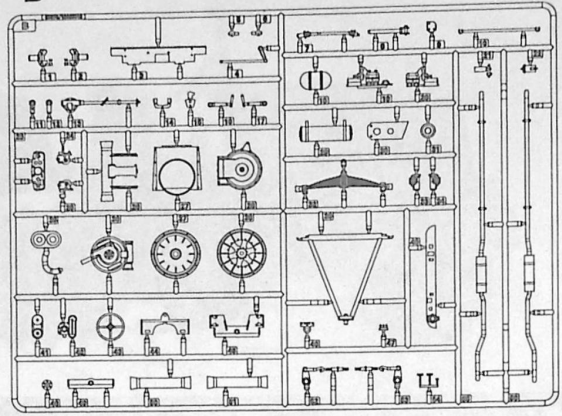

U

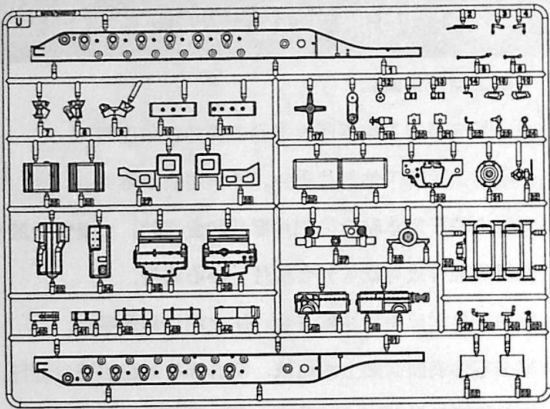

F

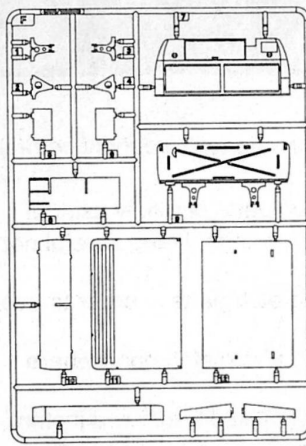

G

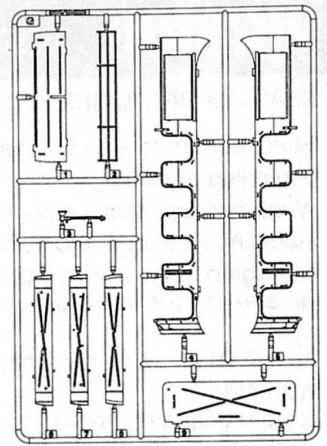

Hx2

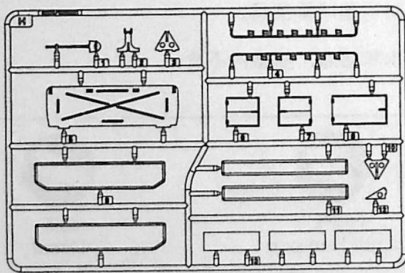

E

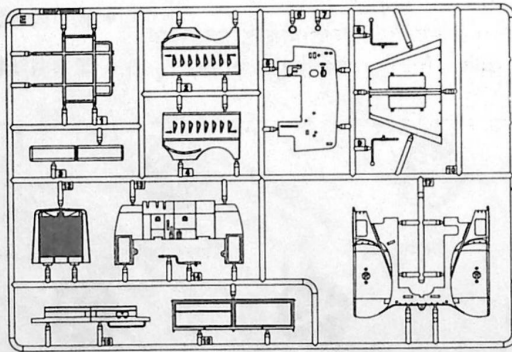

D1

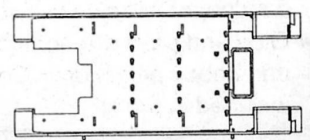

Px3

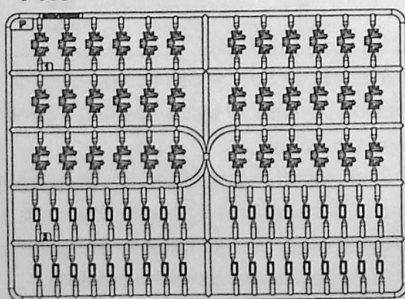

GP

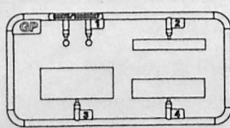

《轮胎》 x3  
Tyre x3

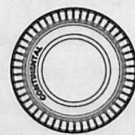

《轮塞》 I  
Poly cap



《轮塞》 II  
Poly cap



《棉绳》  
Rope



《遮盖纸》  
Die-cut mask

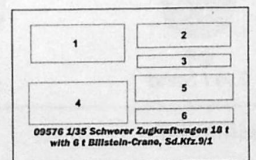

《水贴》  
Decal

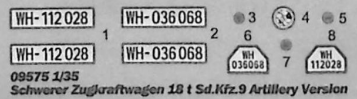

09575 1/35 Schwerer Zugkraftwagen 18 t with 6 t Billastrin-Crane, Sd.Kfz.9/1  
WH-112 028 WH-036 068  
WH-112 028 WH-036 068  
09575 1/35  
Schwerer Zugkraftwagen 18 t Sd.Kfz.9 Artillery Version

1

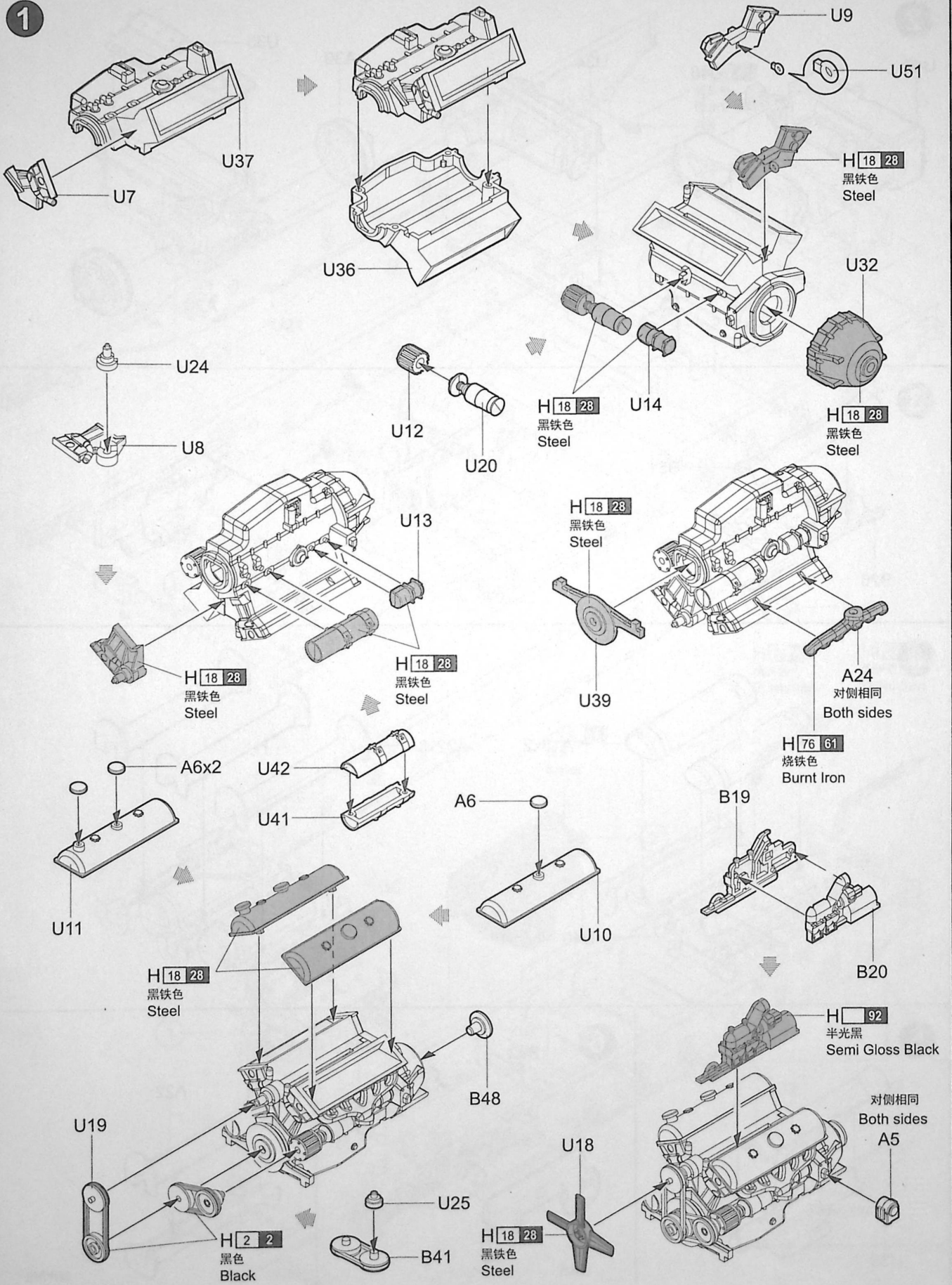

2

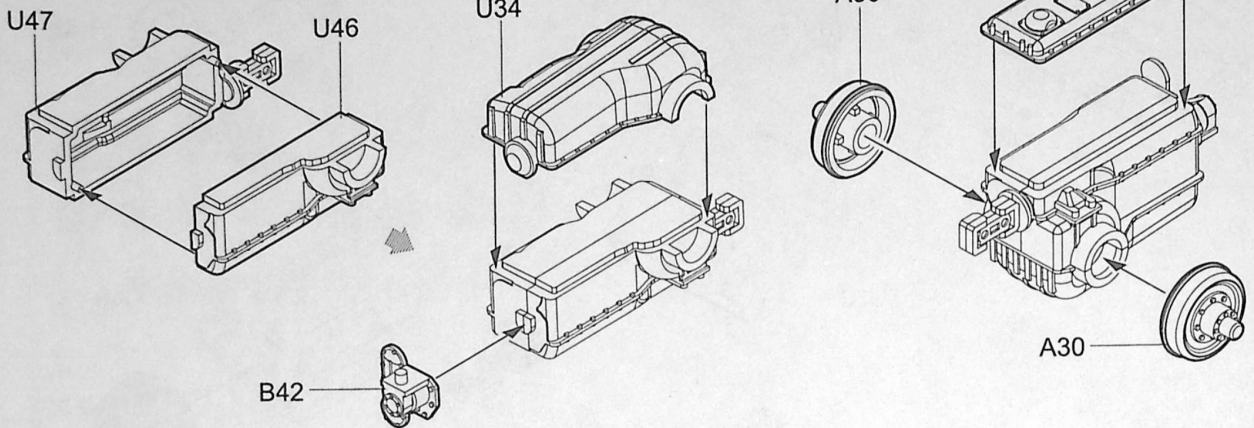

3

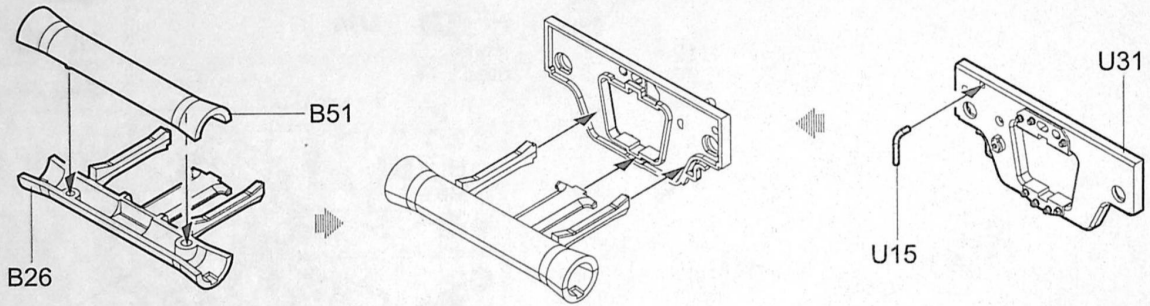

4

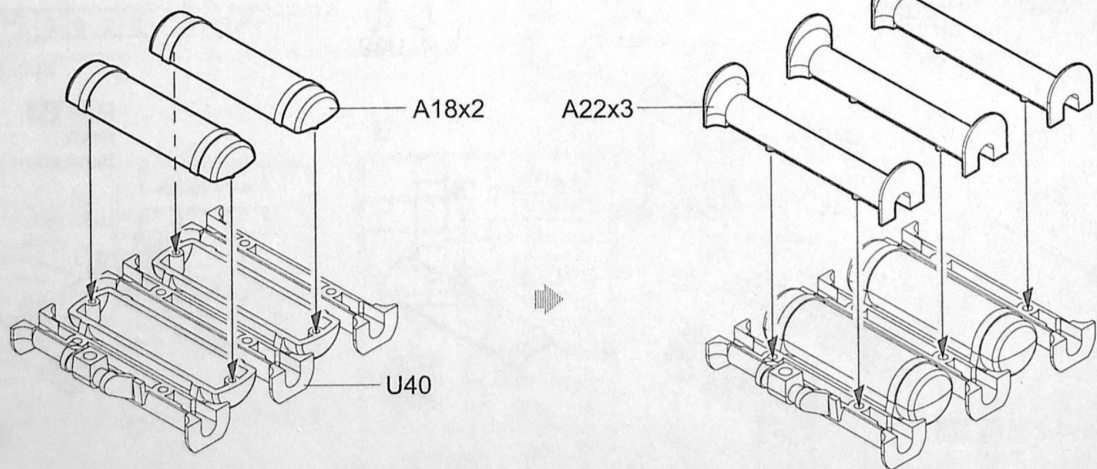

5

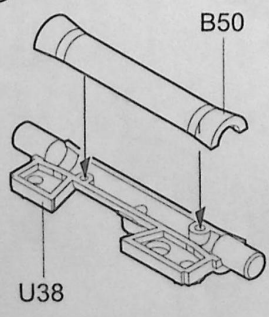

6

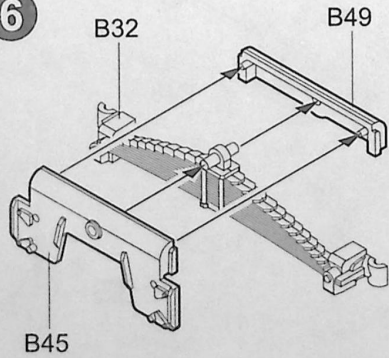

7

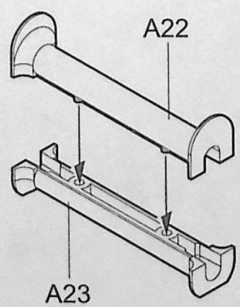

制作3组  
Make three

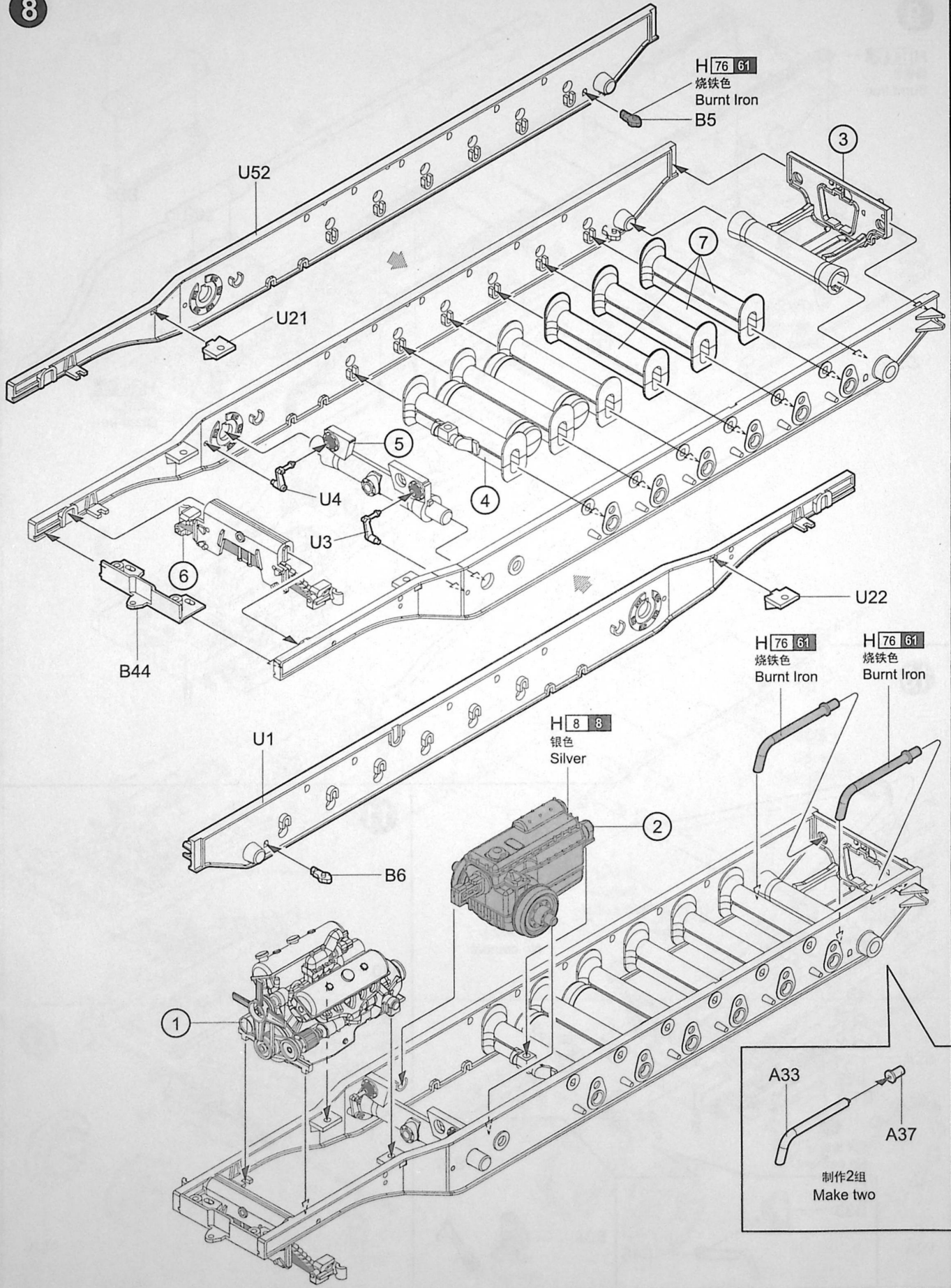

9

H 76 61  
烧铁色  
Burnt Iron

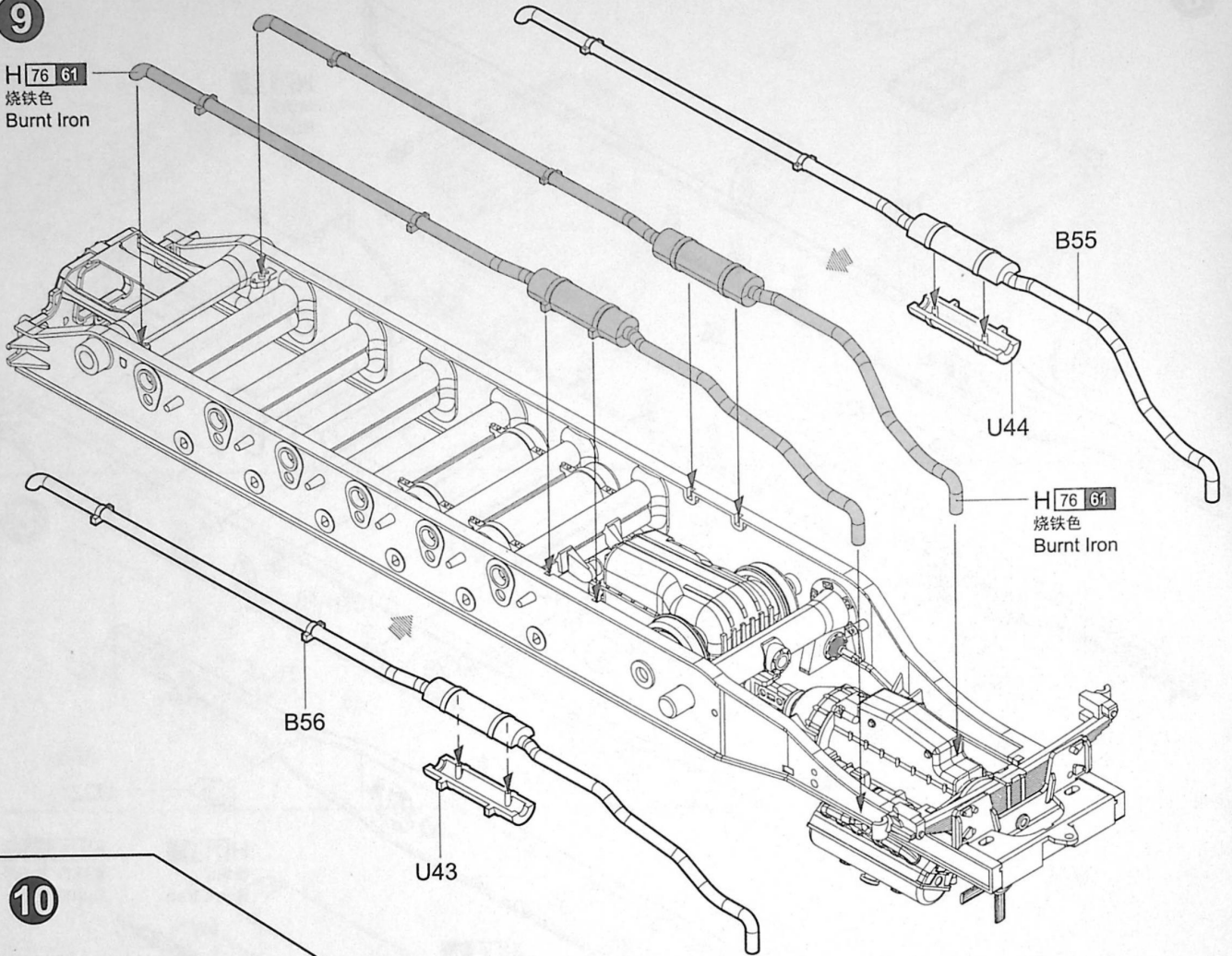

10

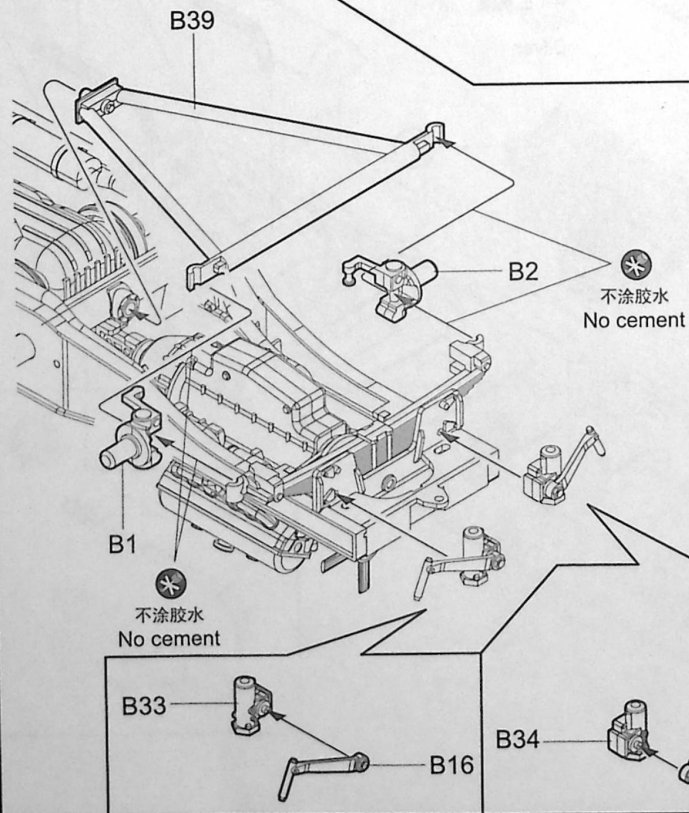

11

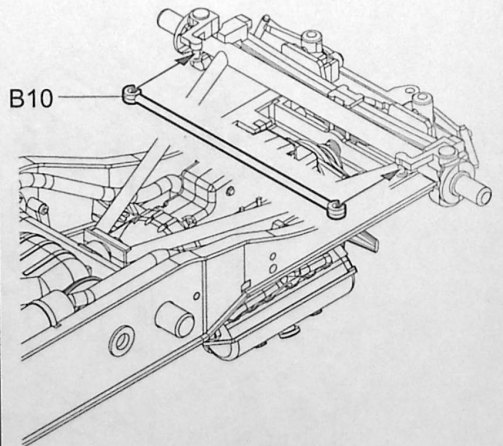



A18

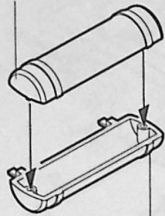

B29

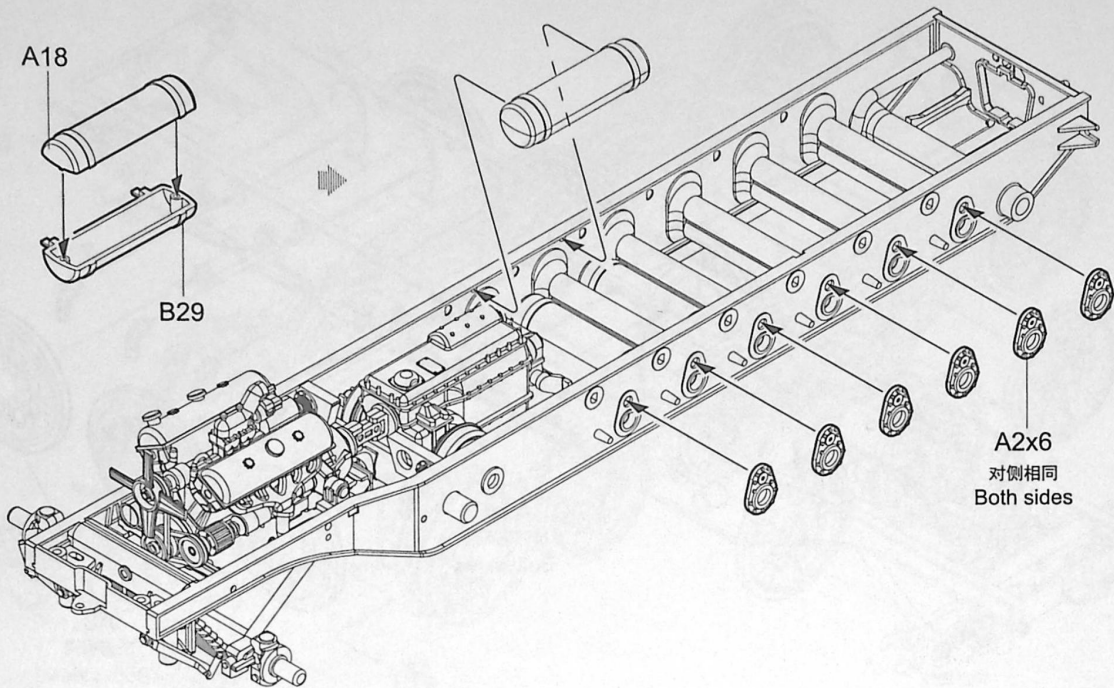

A2x6  
对侧相同  
Both sides

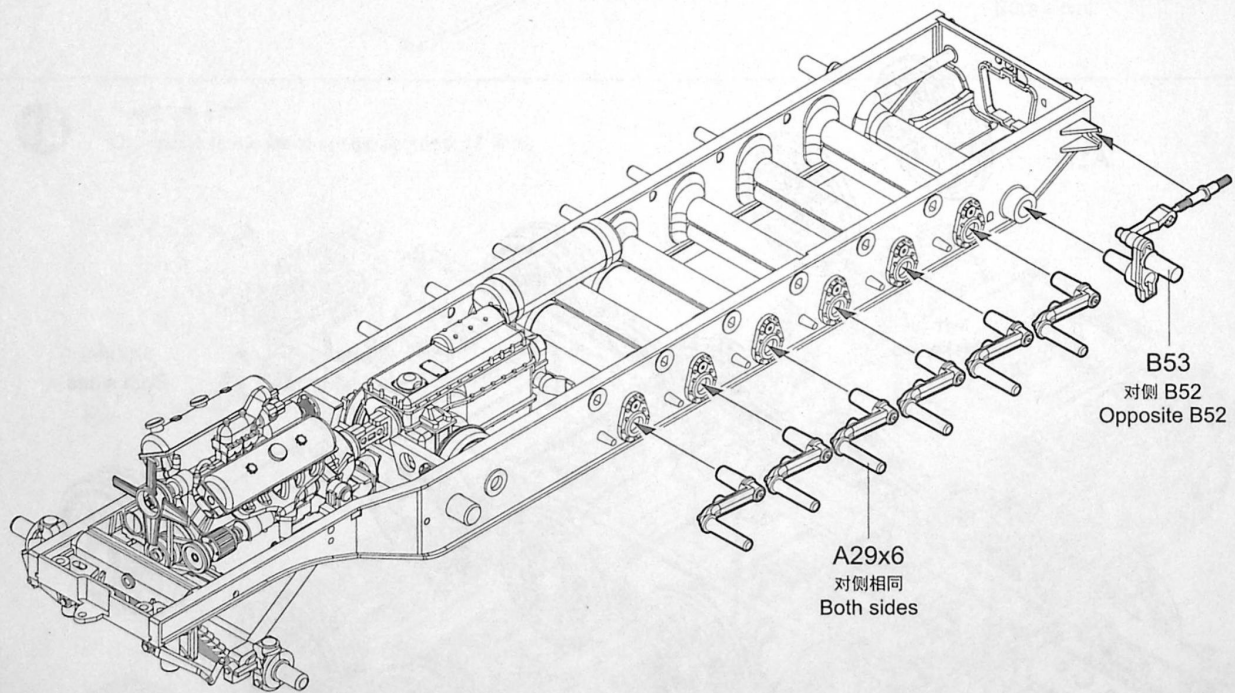

B53  
对侧 B52  
Opposite B52

A29x6  
对侧相同  
Both sides



A31



A32

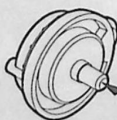

A10

《轮塞》|  
Poly cap

不涂胶水  
No cement

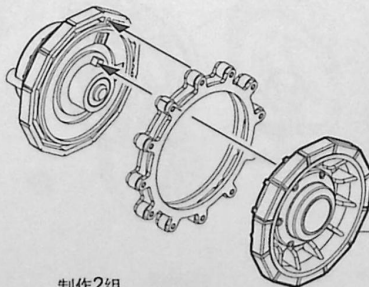

A14

制作2组  
Make two

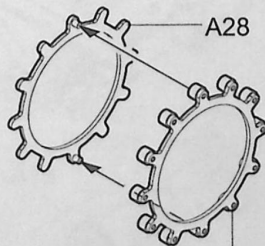

A27

A28

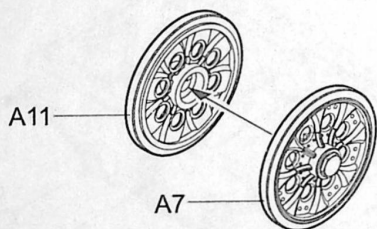
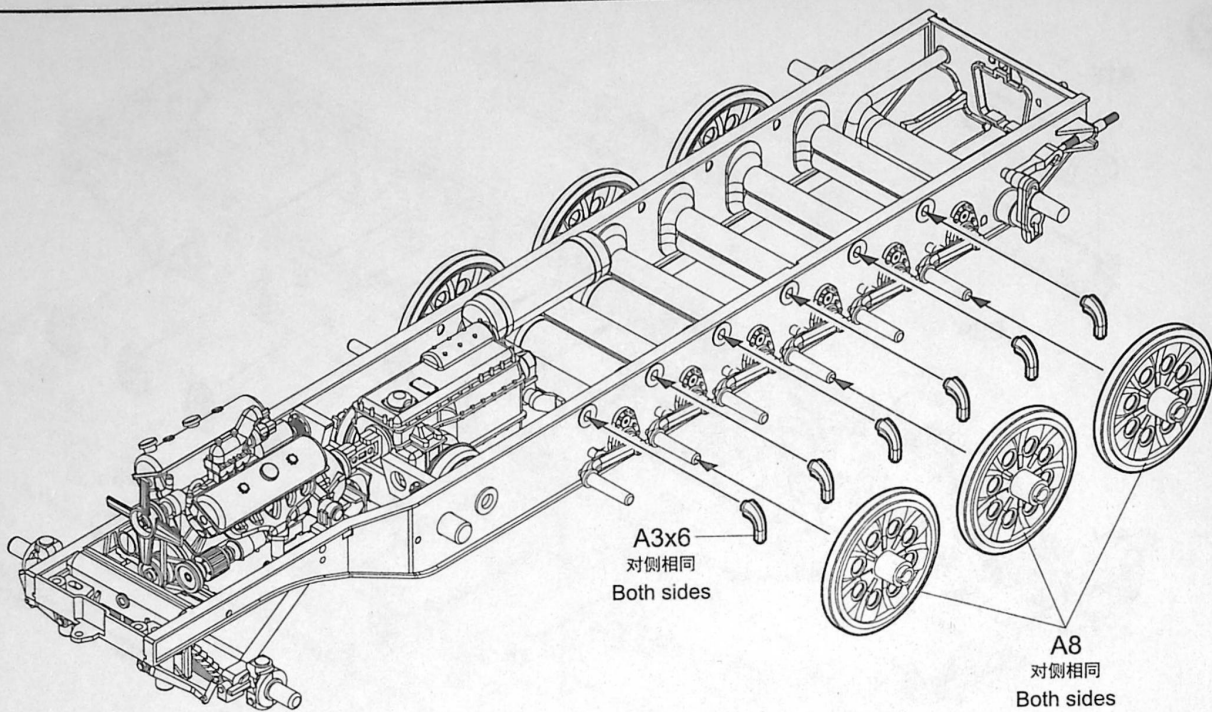

制作2组  
Make two

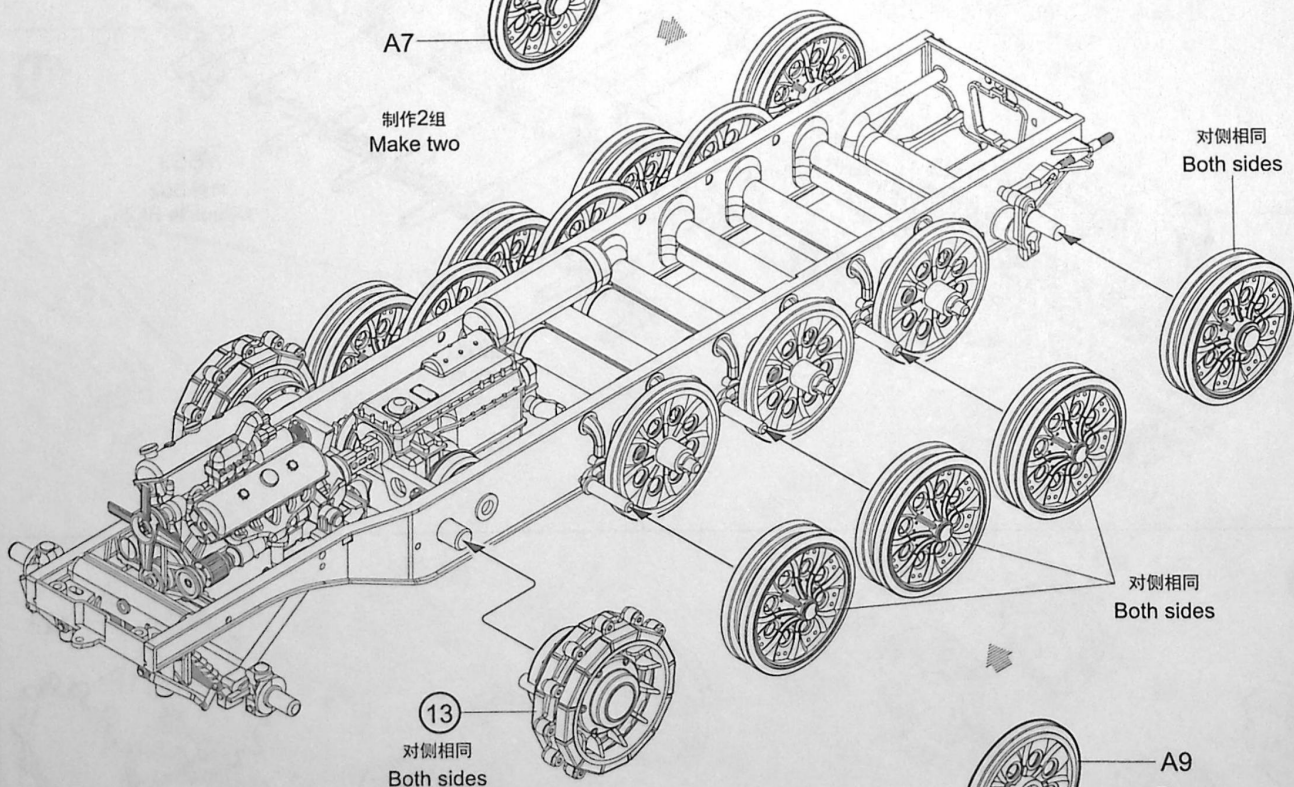

制作6组  
Make six

15

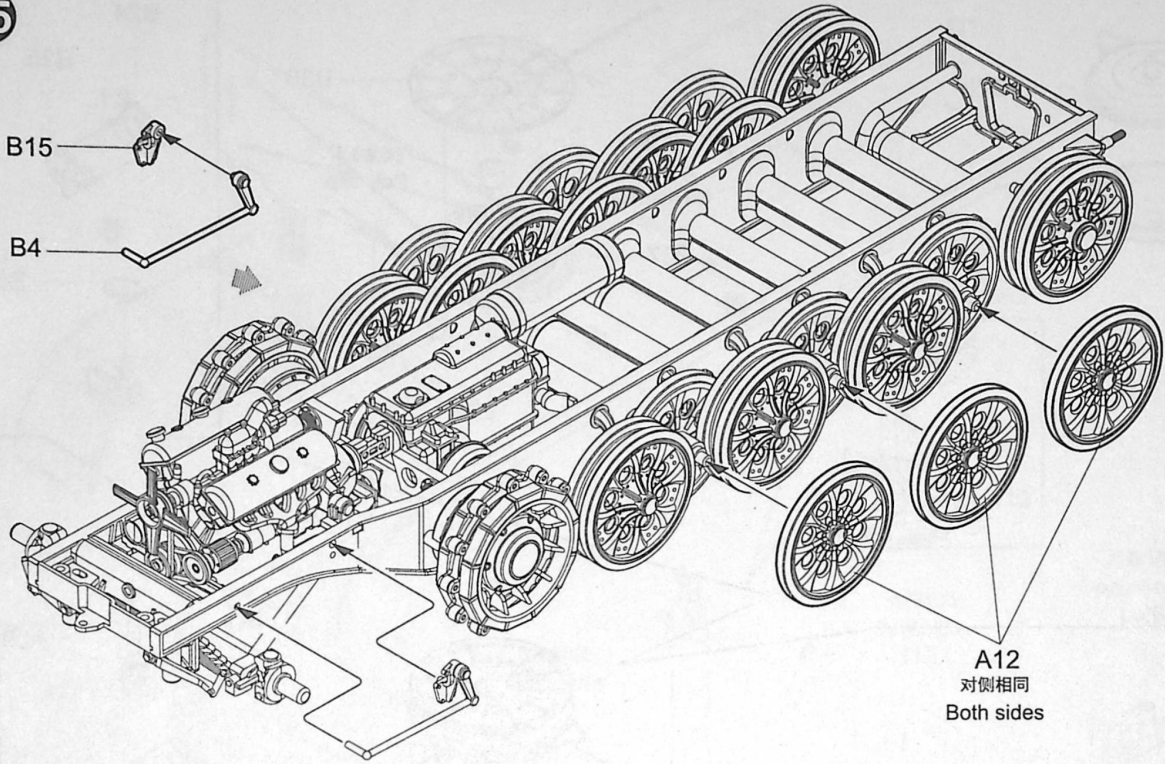

16

单侧履带需 47 节  
Complete track for oneside requires 47 links

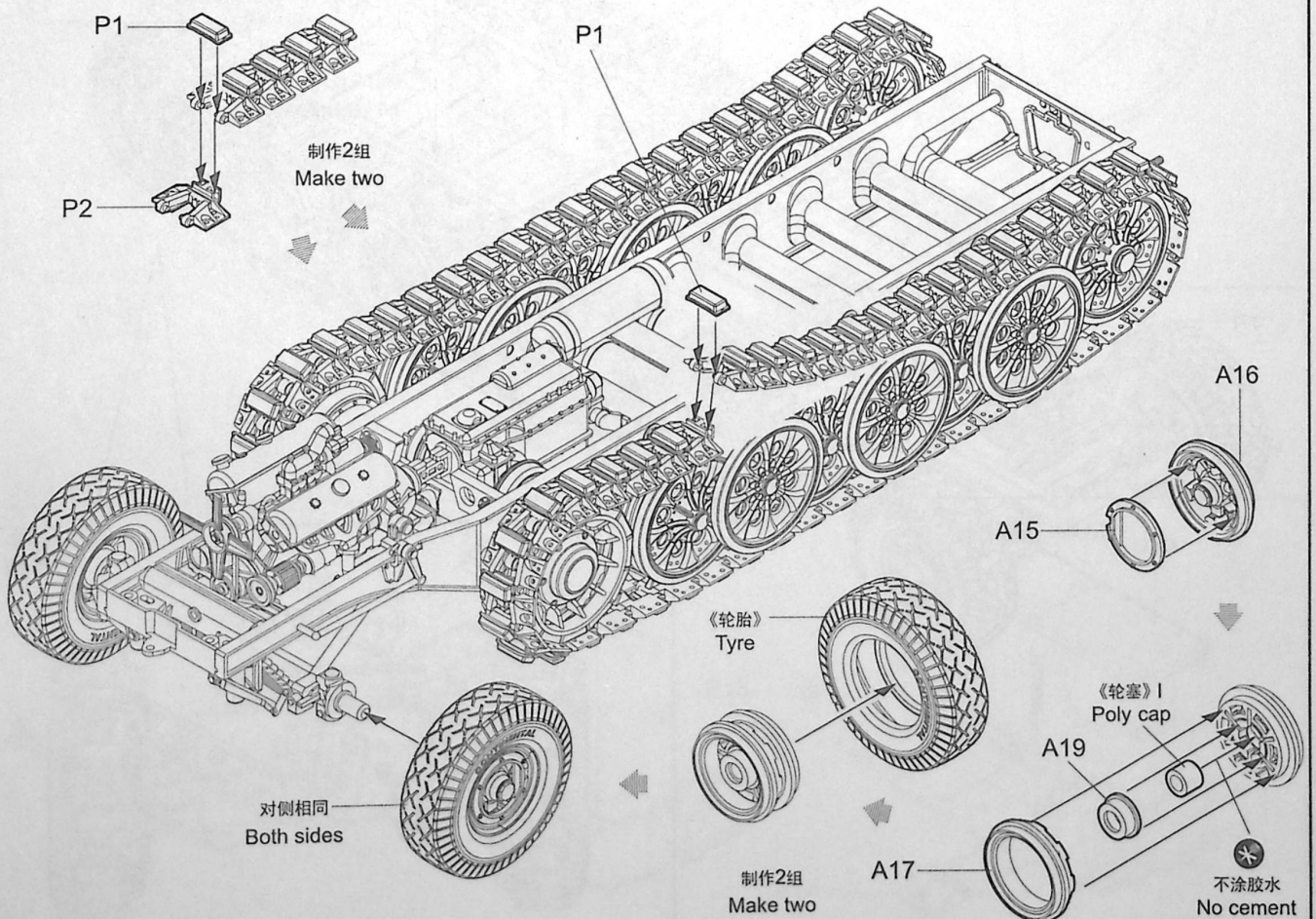

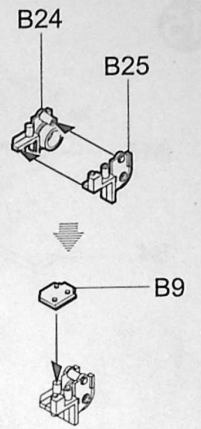
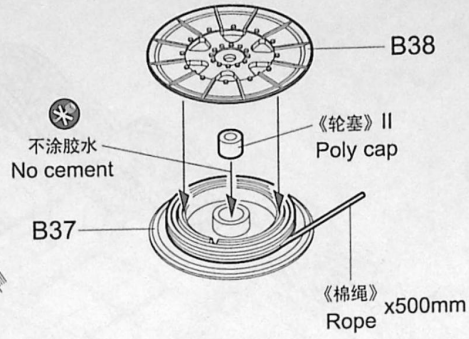
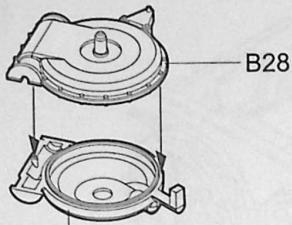

17

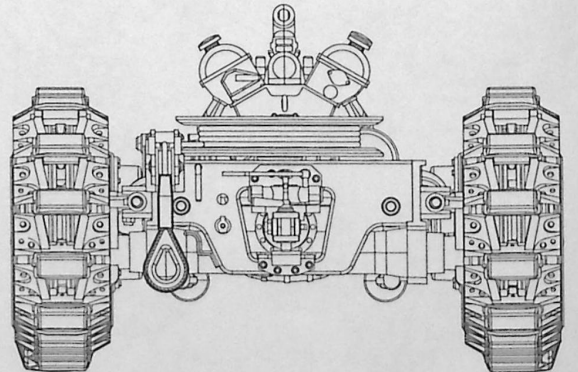
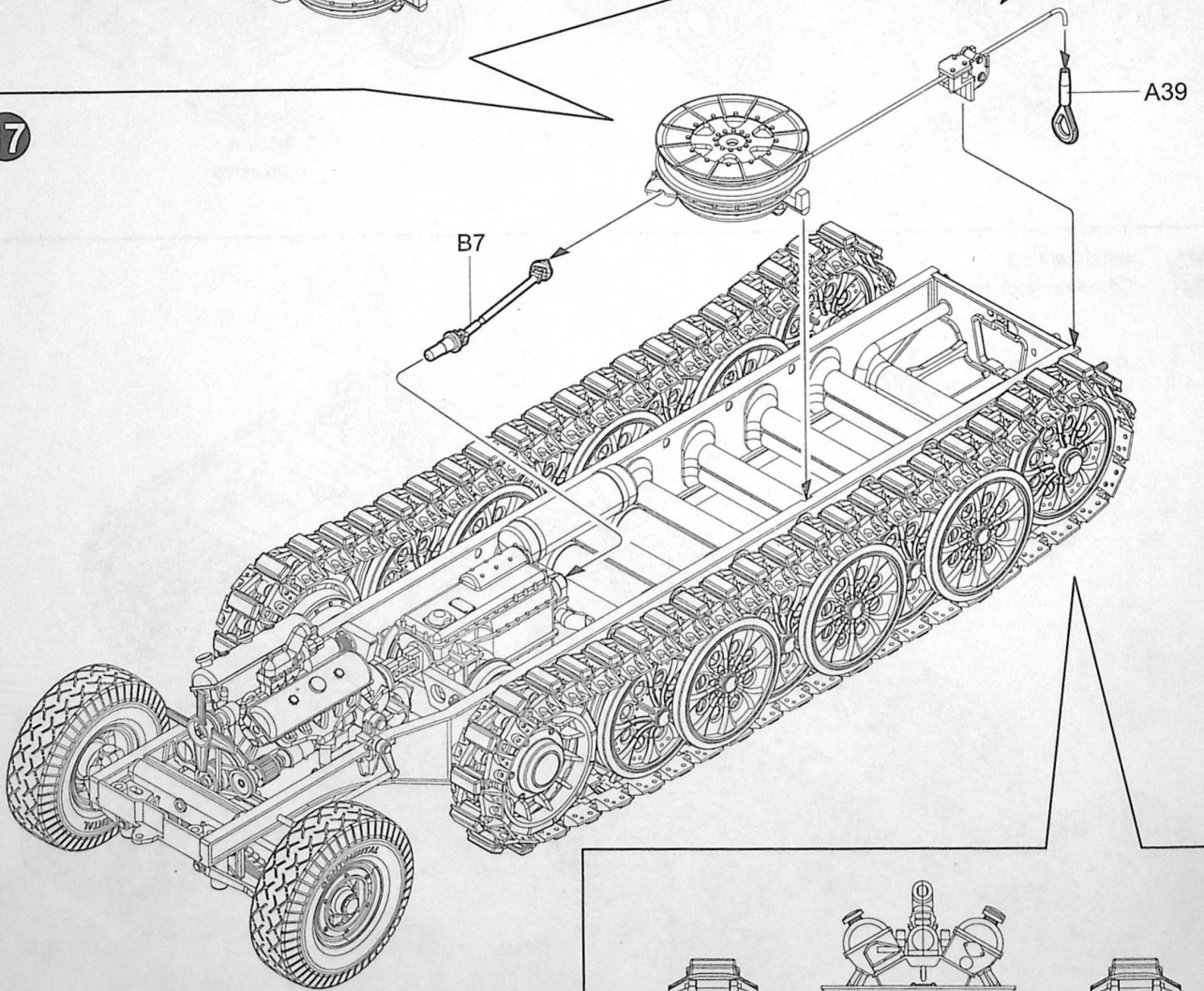

18

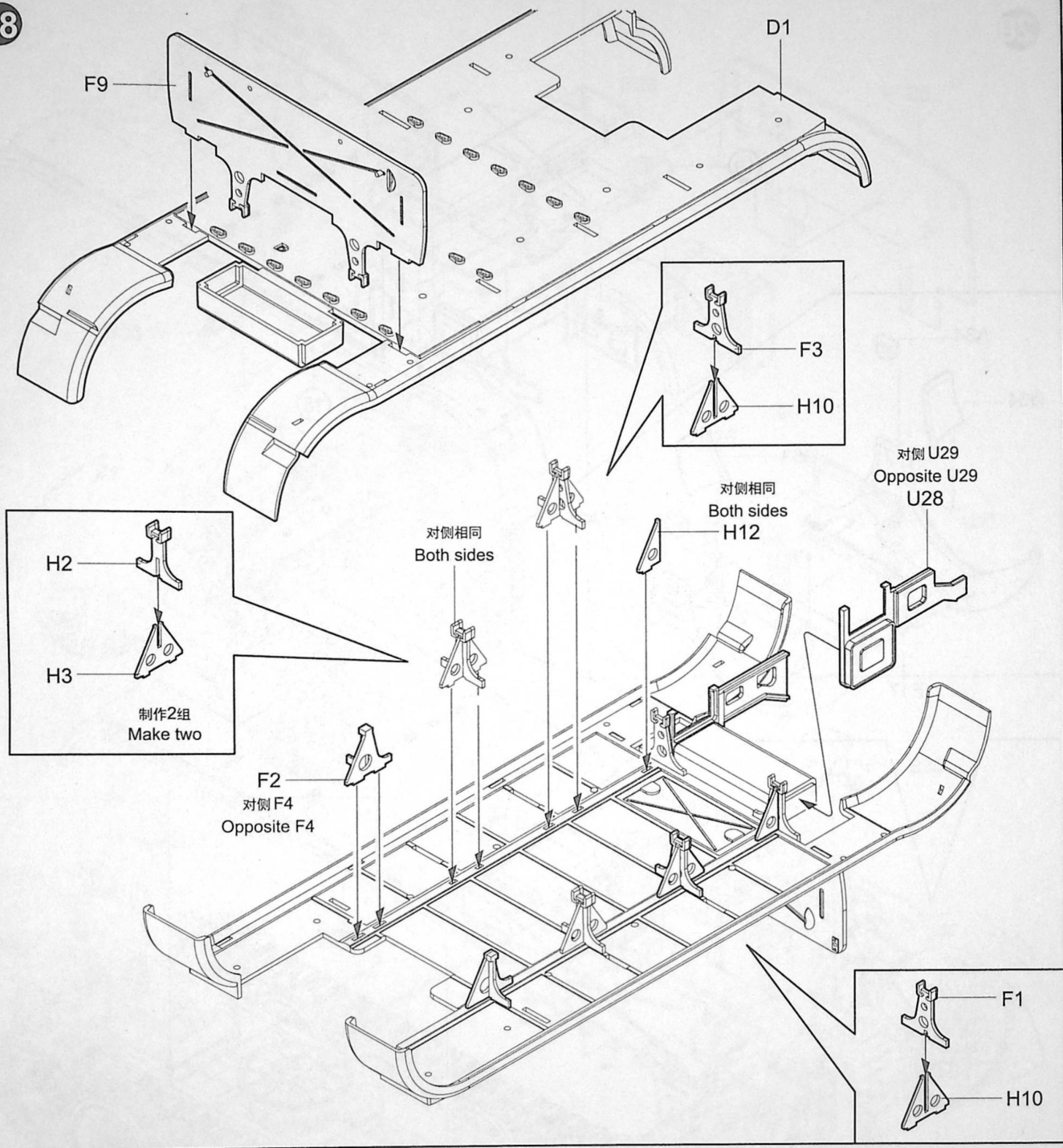

19

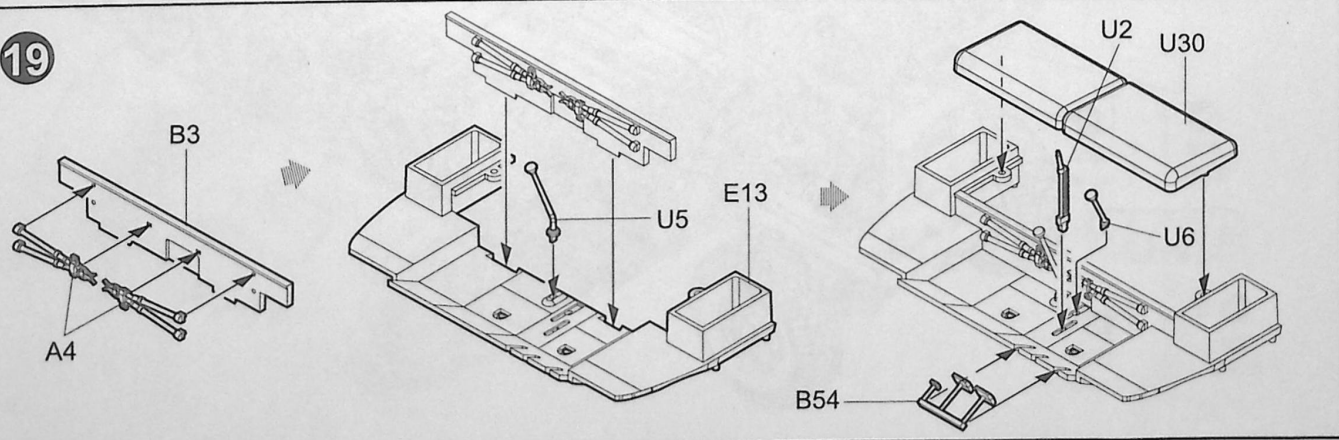

20

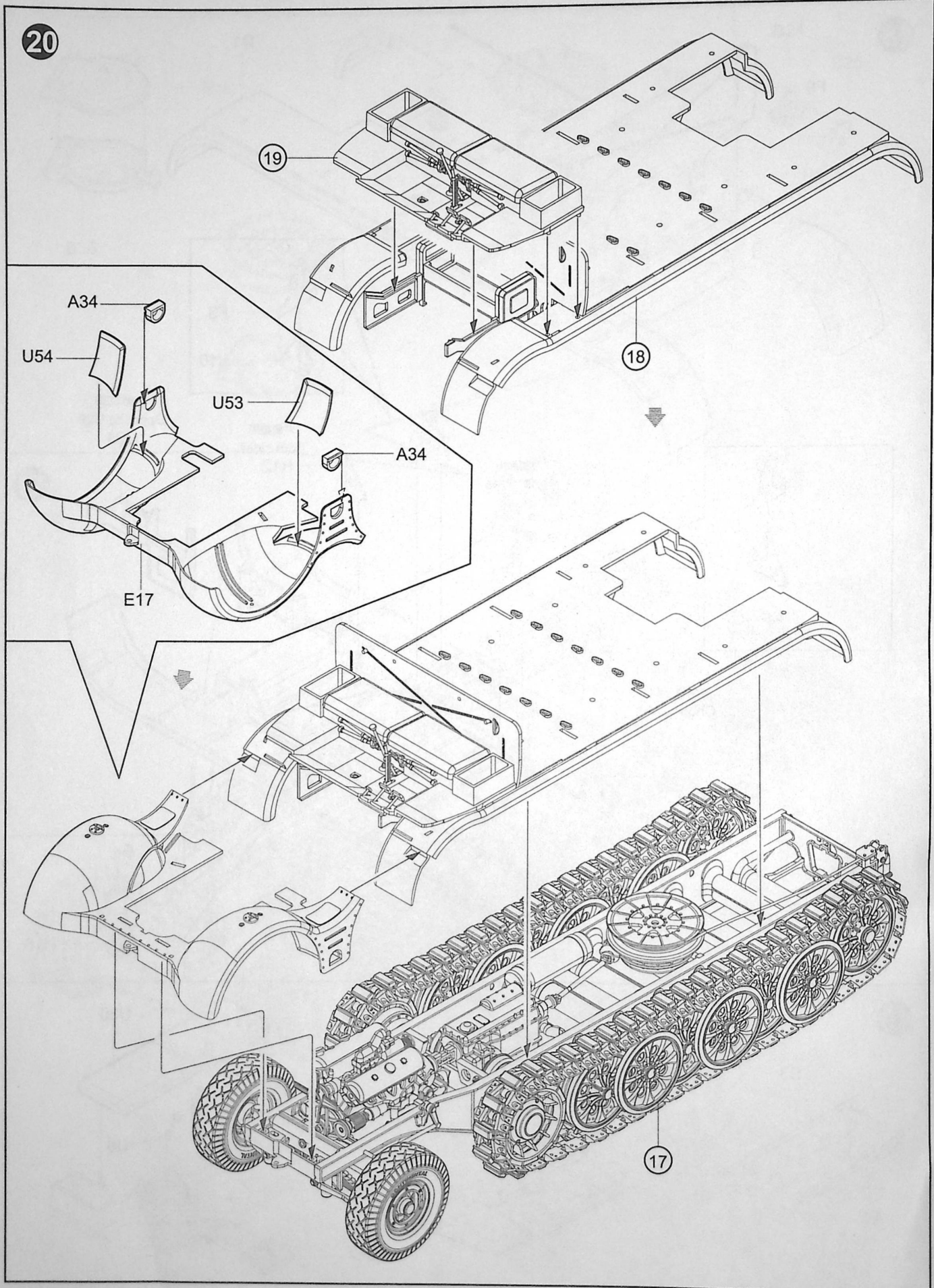

21

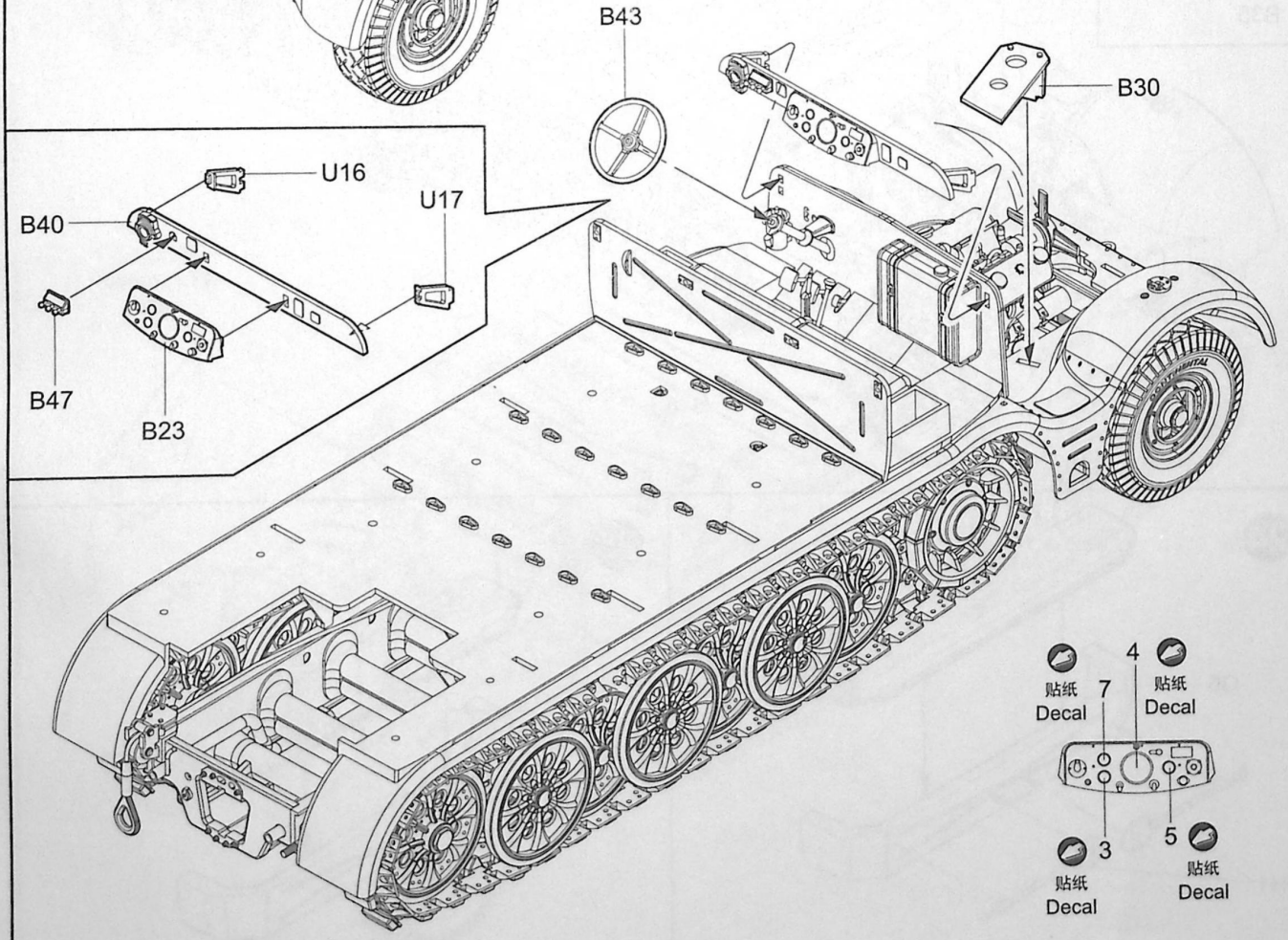
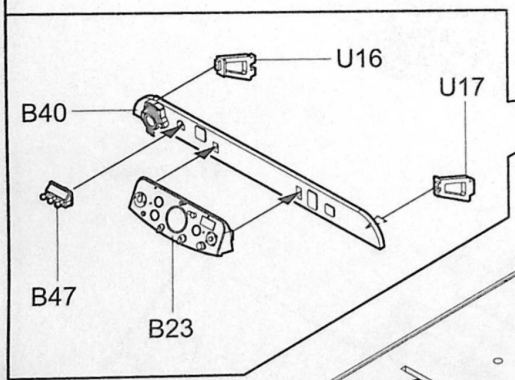
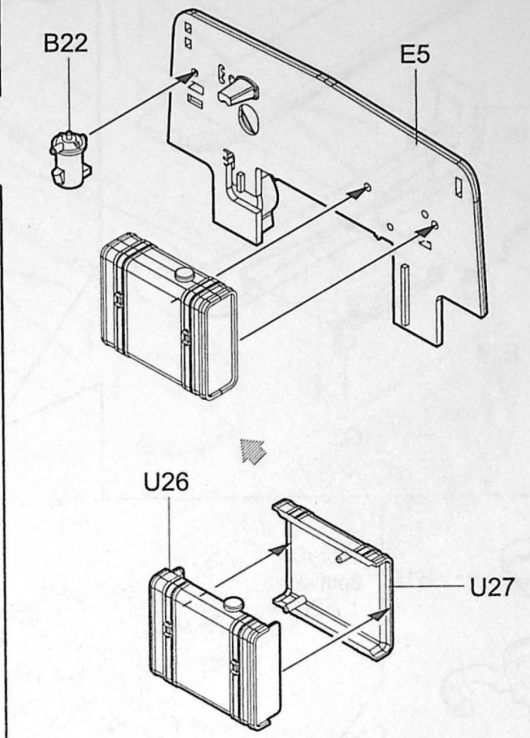
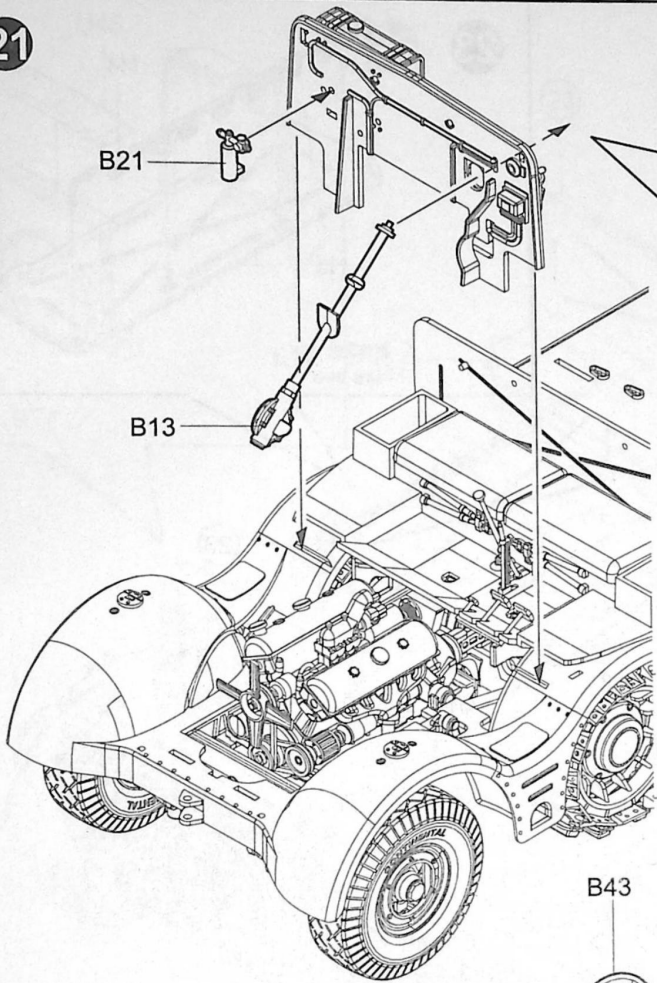

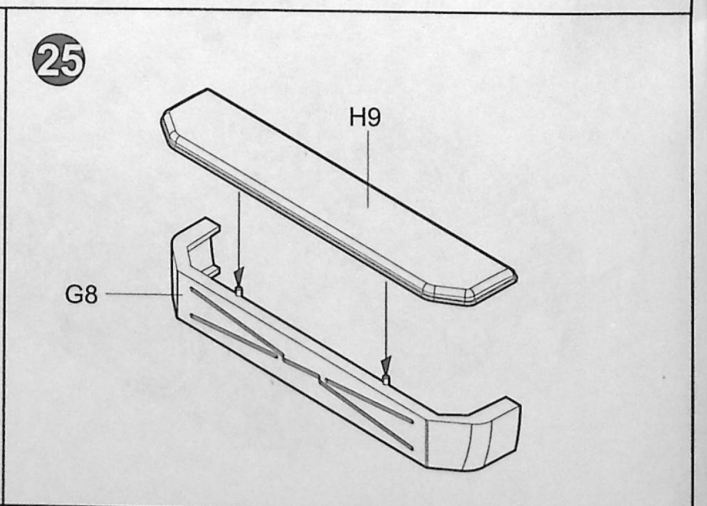
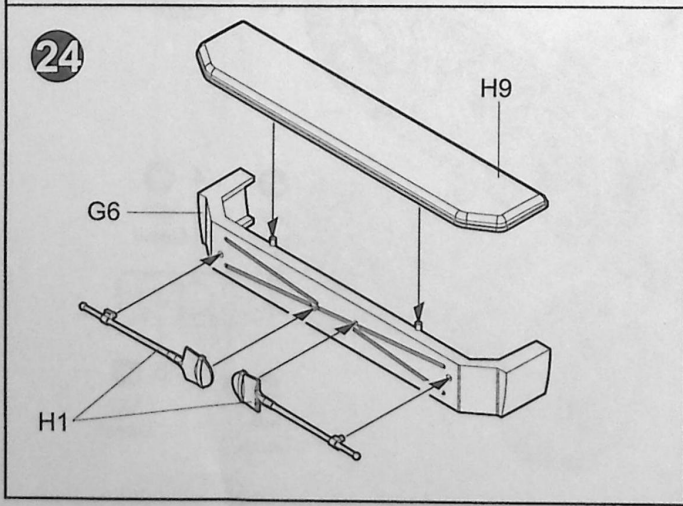
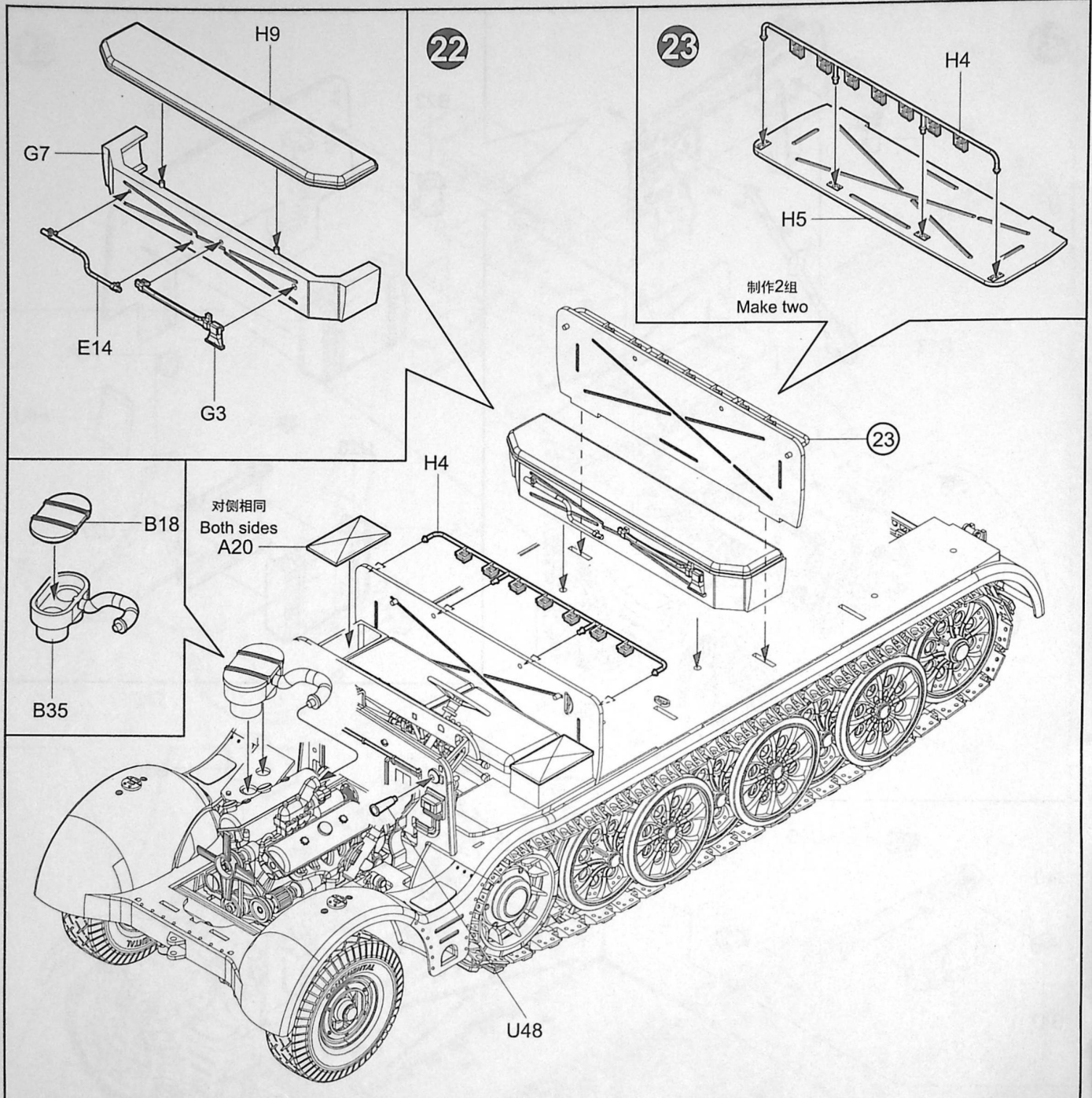

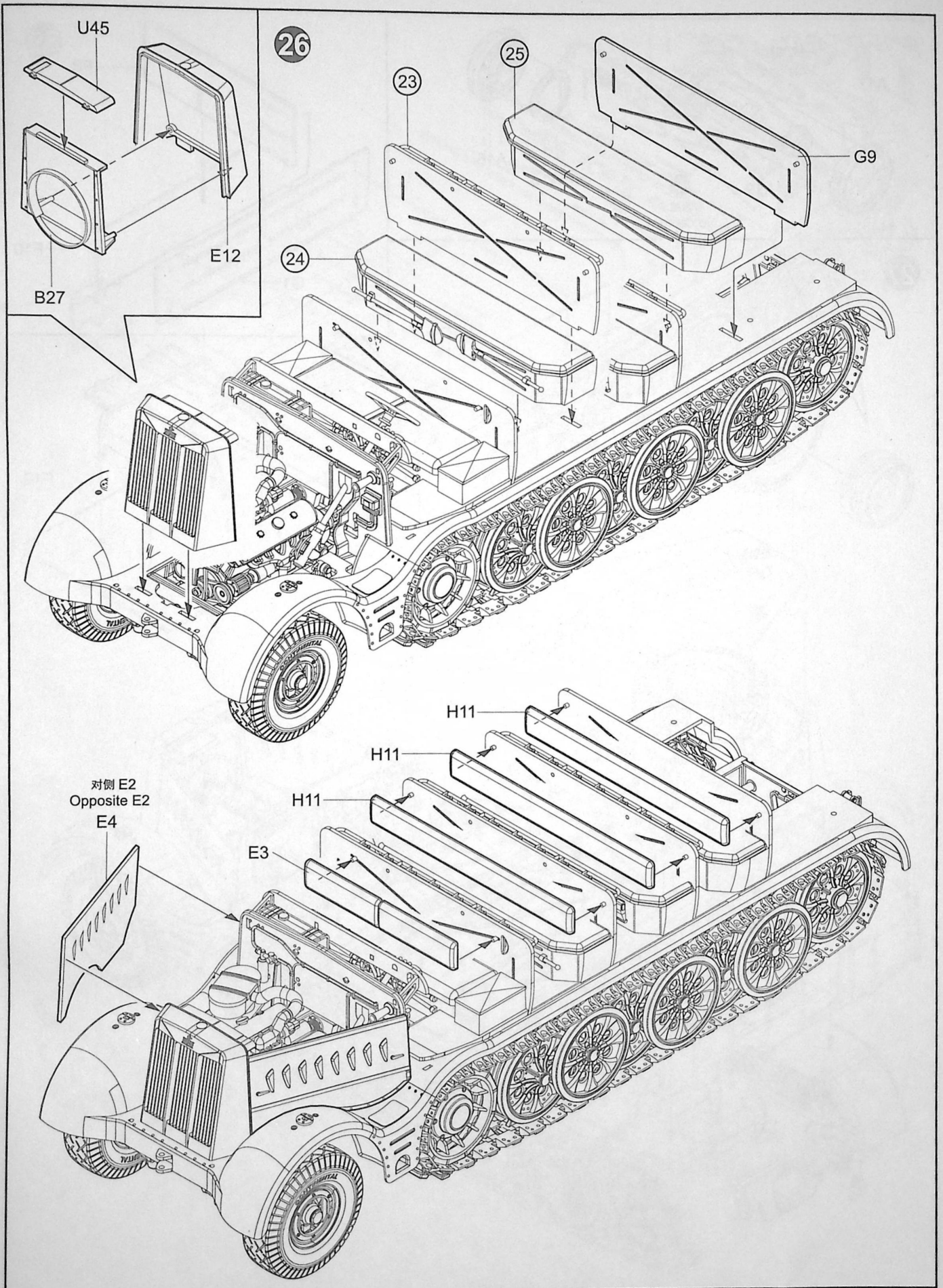

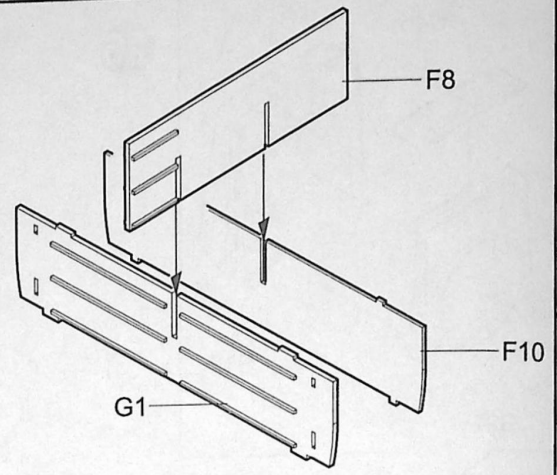
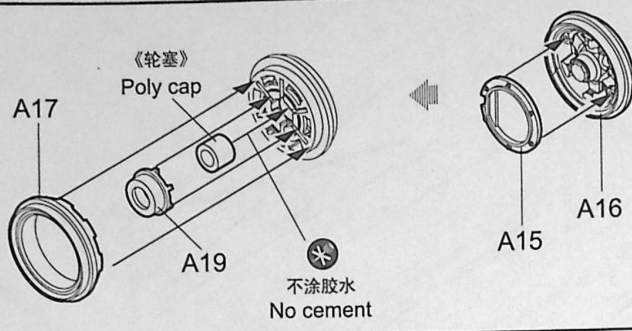

27

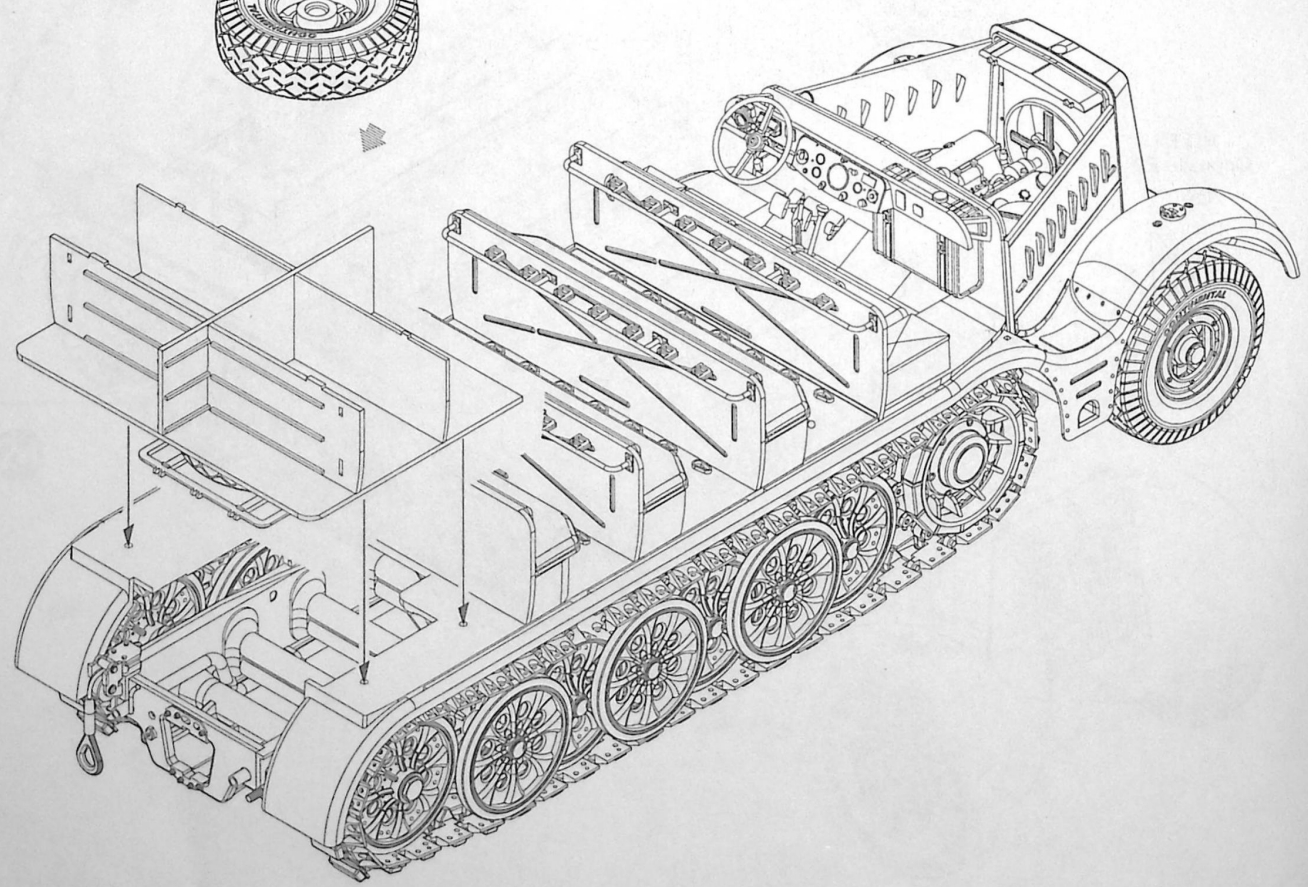
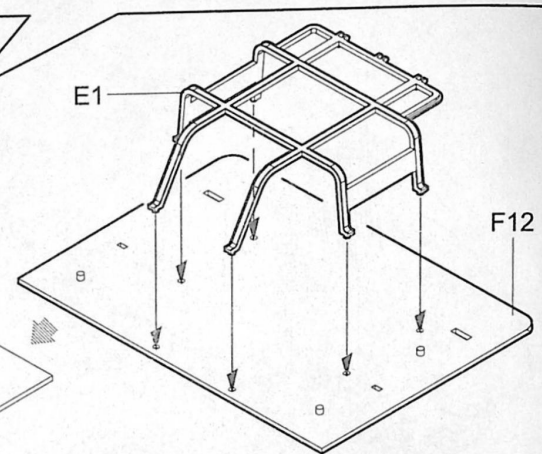
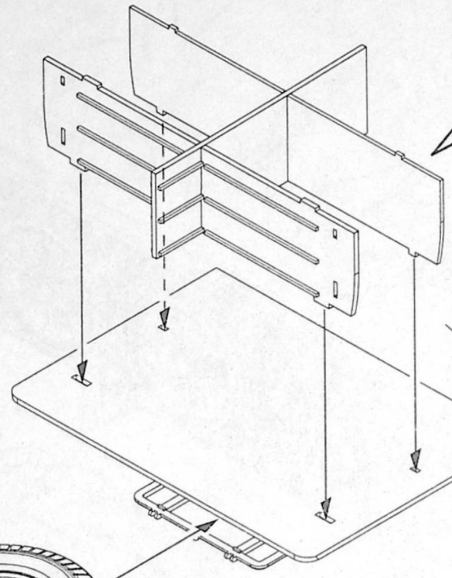
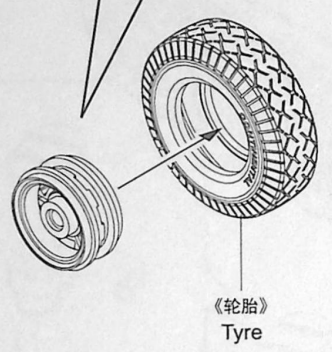

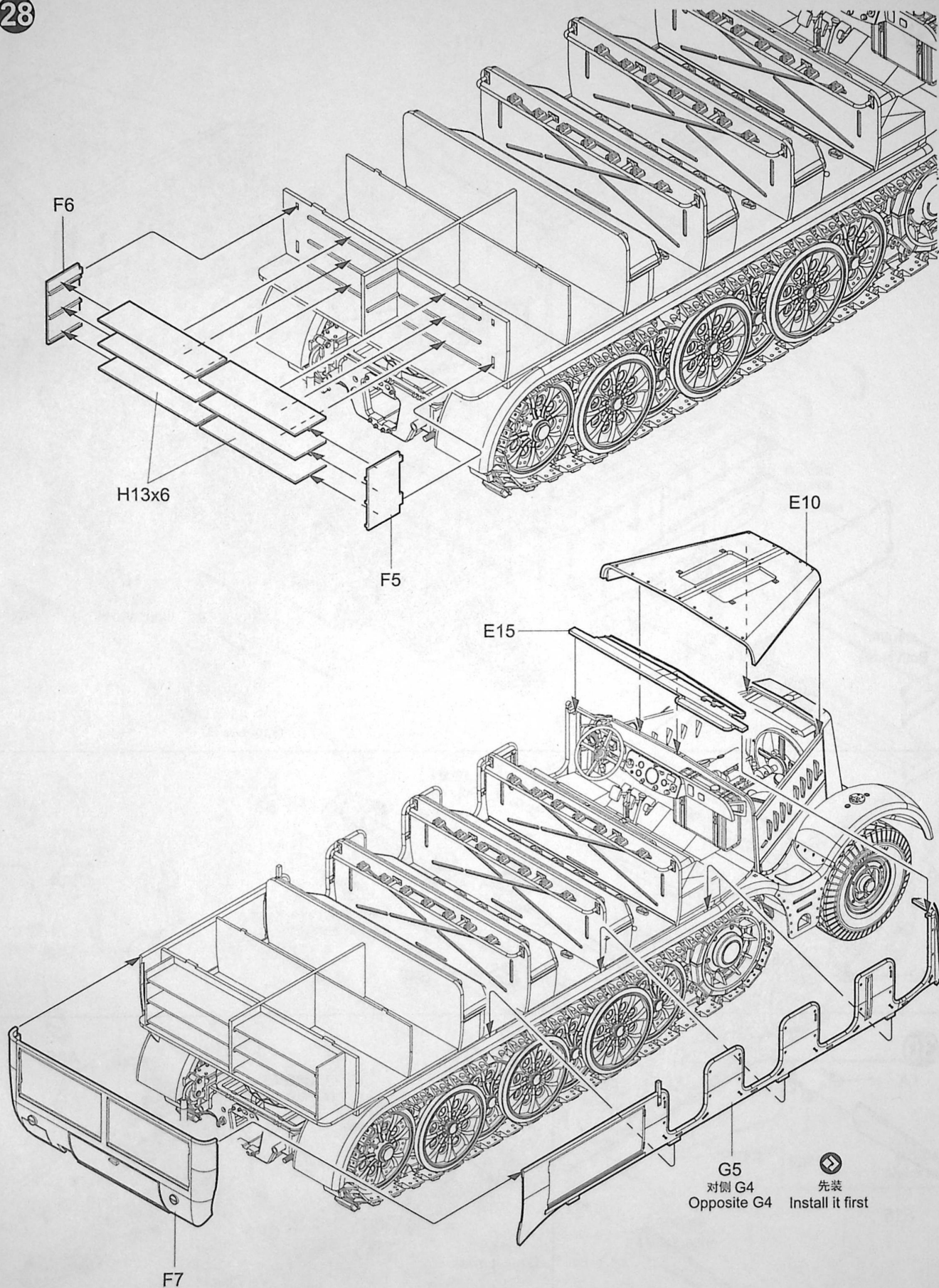

29

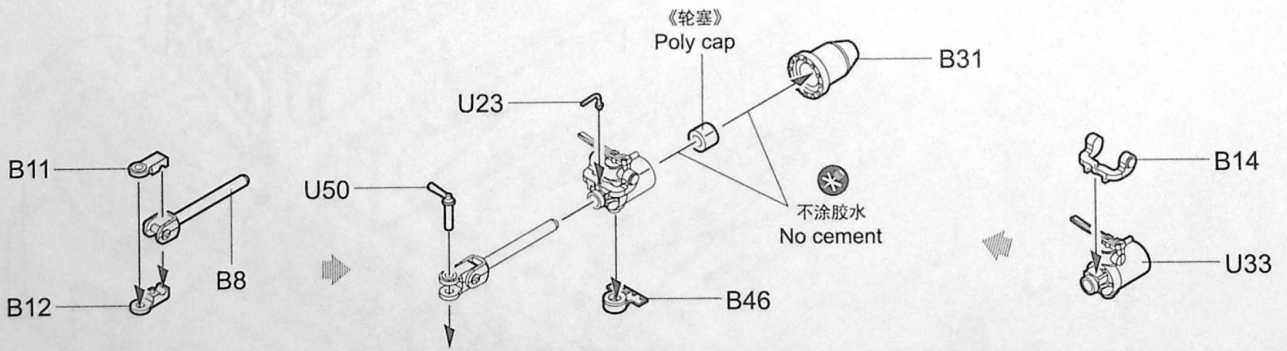
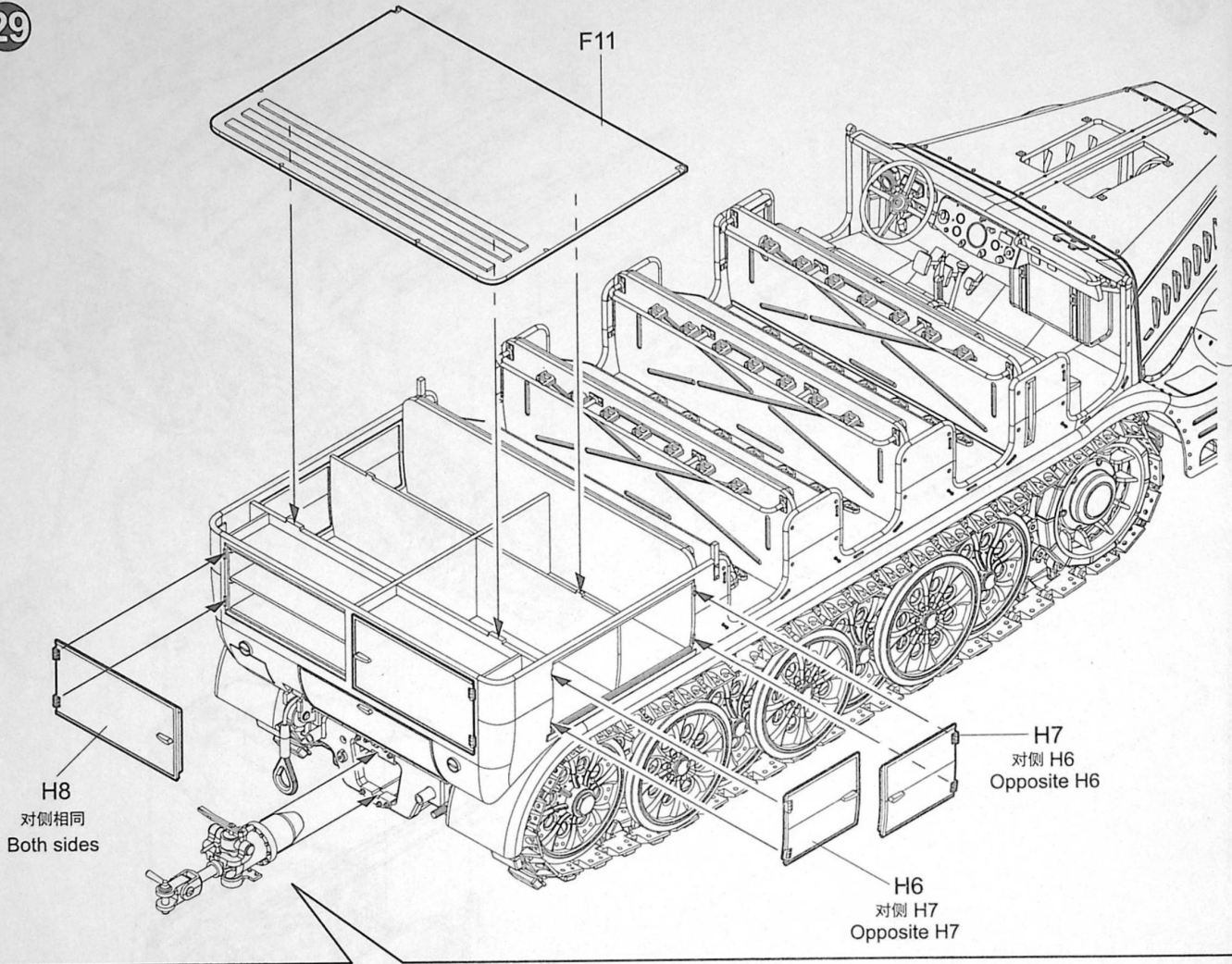

30

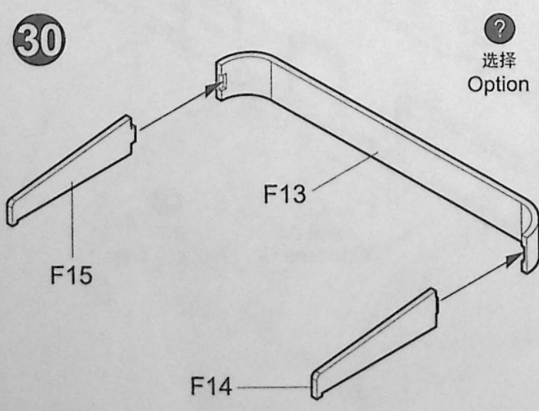

31

