

TITANIC

皇家邮轮“泰坦尼克”号

READ BEFORE ASSEMBLY:

- This kit is not recommended for inexperienced modelers or for children under 14 years of age
- Study and understand these instructions thoroughly before beginning assembly
- When needed, remove photo-etch parts carefully using a modeling knife or photo etch sprue cutter, being careful not to damage or lose small parts.
- Take extra care in handling photo etch parts in order to avoid injury
- Apply instant cement sparingly to photo etch parts where instructed

- Tools recommended(not included in kit):Plastic and instant cements,sprue cutters,long nose pliers,modeling knife, small files, tweezers, pin vise & scissors. Soft cloth and sandpaper will also assist in construction
- Glue and paint are not included in the kit. Use plastic cement and hobby paints only. Color guide for purchasing paint is included in the kit.
- Keep out of reach of children. They must not be allowed to ingest small parts or handle plastic bags in any way.

装配之前仔细阅读

- 小心用模型锉刀锉平所有零件表面的注射浇口。
- 小心用刀片切下蚀刻片零件，不要遗失小零件。
- 用强力快干胶水粘合蚀刻片零件和金属轴。过量的快干胶水使用可能导致可动零件会粘住，小心涂胶。
- 取蚀刻片时应特别注意安全，防止利边划伤手指。
- 某些零件表面需贴上水贴纸，请选择在装配的同时进行。
- 推荐模型工具(自备)：胶水，水口剪刀，长咀钳，刀片，锉刀，镊子钳，钻，剪刀，瞬间快干胶。
- 软布同砂纸同时也应该是必备工具。
- 请使用塑料胶水和油漆，模型内不含。
- 谨防小孩吸吮塑料零件，或者将塑料袋套在头上，制作时应将套材远离小孩接触。
- 本产品不适合14岁以下没有经验的模型爱好者。

水贴纸的使用:

1. 从水贴纸上剪下印花;
2. 将印花放入温水中浸10秒，然后放在干净布上。
3. 拿着印花纸板将印花移到模型上;
4. 手指蘸水将印花移到适当的位置;
5. 用软布轻压印花直至水干，气泡消失。

DECAL APPLICATION:

1. Cut decals from sheet as needed
2. Dip the decal in warm water for about 10 seconds and then place on soft clean cloth.
3. Hold the decal backing sheet edge and gently slide the decal onto the model in its proper position.

4. While still wet, decal can be adjusted for better fit on model by dampening it gently with your finger.
5. When placed in the proper position, gently press decal down with a soft cloth until excess water and air bubbles are gone.
6. Allow decal to dry completely before handling model



使用强力胶
Cyanoacrylate glue



配重
Weight



钻孔
Make hole



切除
Cut / Remove



先装
Install it first



贴纸
Decal



锉平
File / Sand



选择
Option



不涂胶水
No cement



弯曲
Bend

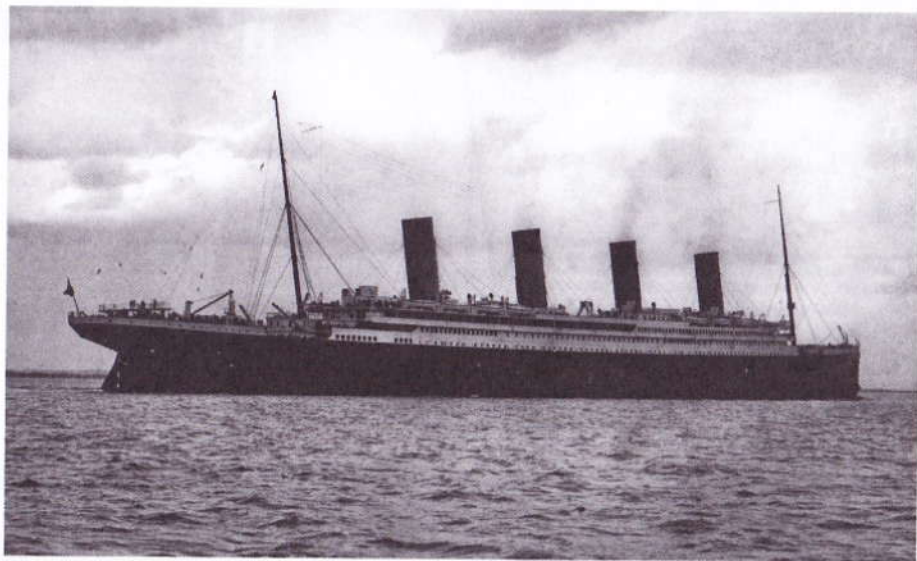

① Titanic makes her way past Cowes off the Isle of Wight on her way to the English Channel, 10 April, 1912.

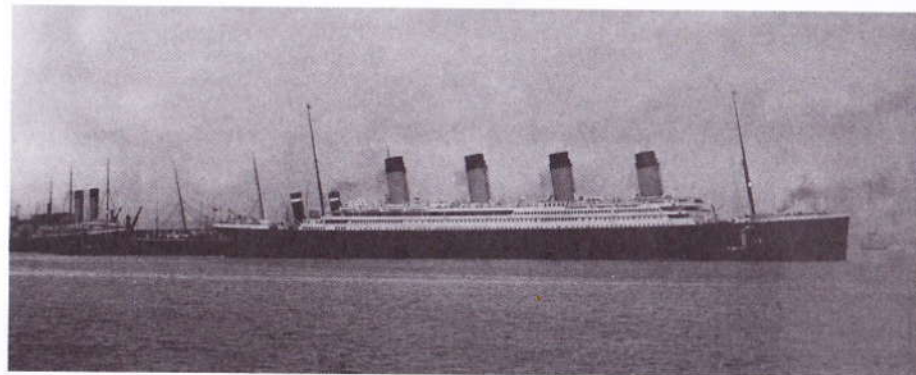

② Titanic is brought to a stop following the near collision with the American Line steamer S.S. New York, which is almost hidden behind the stern of Titanic.

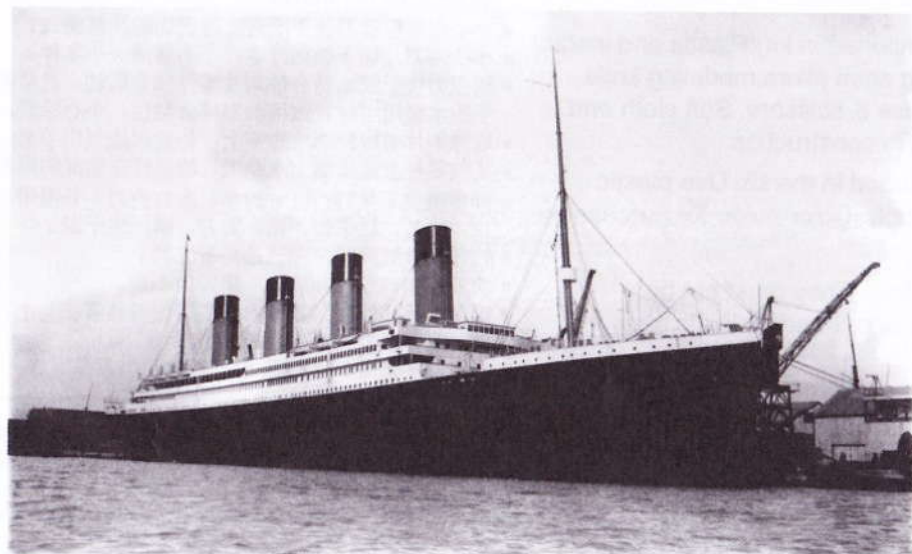

③ Titanic sits at berth 44 of the White Star Line dock in Southampton, 8 April, 1912.

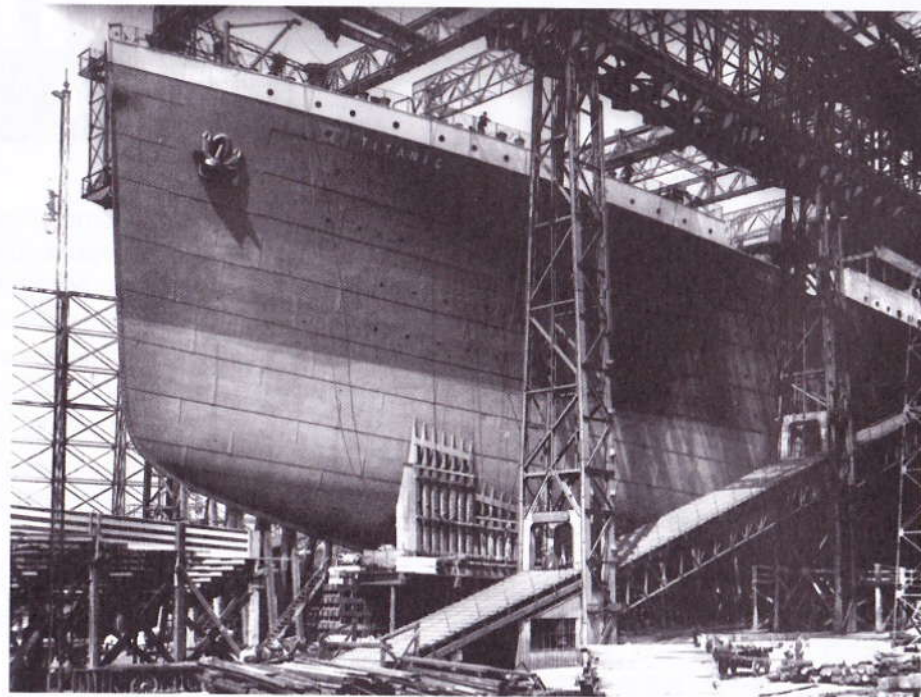

④ May 1911 and Titanic sits on slipway 3 of the Queens Island yards of Harland & Wolff, Belfast, as she is made ready for her launch.

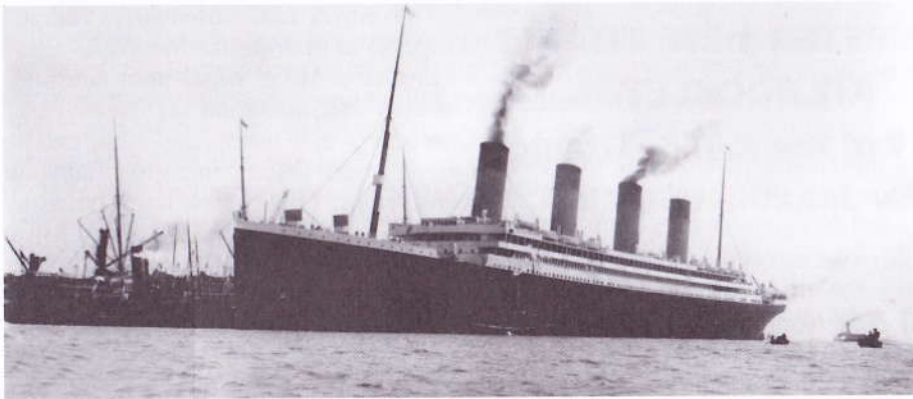

- 5 The first of the Olympic Class sisters; R.M.S. Olympic. She entered service in June 1911 and is seen here being guided by tugboats as she makes her way to the White Star Line dock in Southampton during the mid summer of 1911.

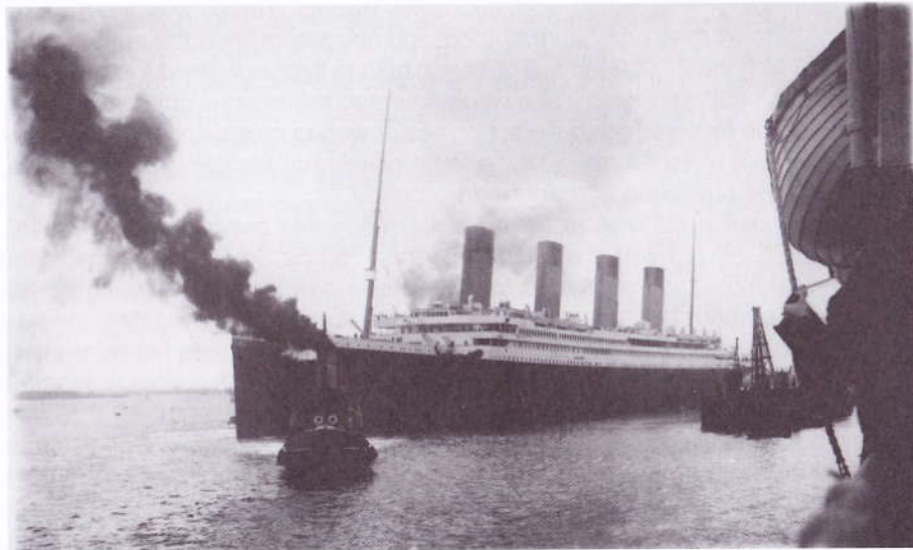

- 7 10 April, 1912 and with tugboats assisting Titanic has been guided from the White Star Line dock and into the deeper waters of the River Test which open out into Southampton Water. As the new liner starts her maiden voyage she passes berth 41 as spectators on board the S.S. Beacon Grange photograph the departing liner.

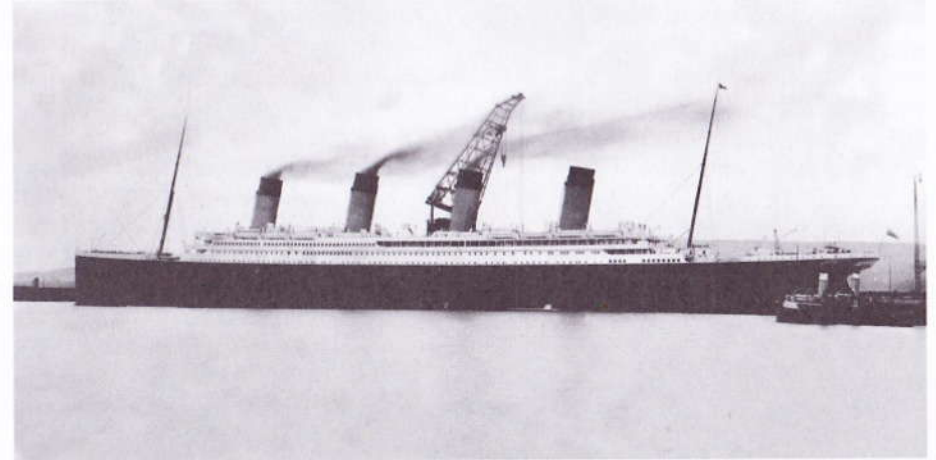

- 6 Heavy winds blow across Belfast on 1 April 1912 as Titanic is fired up for her sea trials. As the winds increase the decision is made to cancel the trials. They would resume the following day where the new liner passed with flying colours.

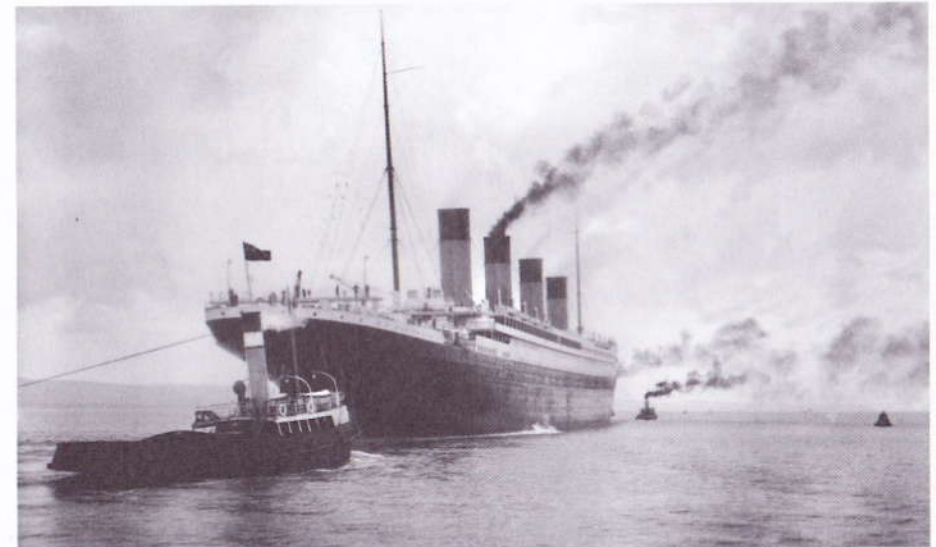

- 8 It is the early morning of the 2 April 1912 and Titanic is guided by tugboats from the Alexander Towing Company through the shallow waters of the Victoria Channel of Belfast and out towards Belfast Lough for a full day of sea trials.

TRUMPETER 1:200 TITANIC KIT BOOKLET

Story of the R.M.S. Titanic

By Jonathan Smith

The Royal Mail Steamship Titanic was designed to operate for the White Star Line as part of a trio of passenger liners for the lucrative Southampton to New York, via Cherbourg in France and Queenstown in Ireland trade. Once completed Titanic would join Olympic (1911) then later joined by the third of the Olympic-class fleet, Britannic

(1914) which was still under construction in Belfast. Titanic was constructed alongside her older sister Olympic at the world famous Harland & Wolff shipbuilders located at the Queens Island yards in Belfast, Northern Ireland. Her keel was laid down on slipway No.3 on the 31 March 1909 as yard build number 401. To ease pressure on the workshops at the yard both Olympic and Titanic's construction had a lapse of six months between them as hull frames, hull plating and many other hull components were crafted. Titanic was designed to represent the finest in shipbuilding technologies of Great Britain during the Edwardian period leading to financial gain for her owners and the ultimate in luxury for her passengers. In October 1910 the White Star Line proudly proclaimed in print that both the liners were constructed in such a way that via a flick of a switch closing the hulls watertight door systems it rendered Olympic and Titanic "unsinkable". A terminology that would later haunt her owners. Titanic was made ready for launch on 31 May 1911 as over one-hundred-thousand spectators lined the embankments of the River Lagan to watch the 24,000 ton hull of Titanic take to the oily water. Moments later she was pulled to the fitting out quay where she would undergo ten months of interior and power plant installations as she received her boilers, engines, towering masts and funnels and some of the finest interiors that matched many of the large stately homes and establishments that defined the rich and the privileged of modern day society.

Titanic was every part a titan. At the time of her entry into service she was 882ft. 9in (269.1m) in length, 92ft. 6in (28.2m) at her widest beam, 175ft (53.3m) from her keel to the top of her funnels and 46,328 gross registered tonnage making her not only the worlds largest passenger liner but the worlds largest man-made movable object of her time. Her funnels were large enough in diameter to allow passage of a steam locomotive while her largest anchor weighed an impressive 15.5 tons and took a team of twenty Clydesdale horses with a haulage dray to transport it to the shipyards. And at her stern was her gigantic steel rudder that weighed 101 tons and towered 78ft. 8in in height. Her immense hull could be pushed along at a steady speed of 21 knots and with an estimated top speed of 24 knots (27mph). Her 29 boilers, 24 double ended and 5 single ended, had a combined total of 159 furnaces where 176 firemen fed the boilers an estimated 650 tons of coal by hand over a 24 hour period. Her outer manganese bronze three bladed propellers had a diameter of 23ft.5in (7.2m) and were propelled by a pair of four-cylinder triple-expansion reciprocating steam engines that had a combined weight of 915 tons and produced a combined 30,000hp. Her solid manganese bronze centre propeller of 16ft. 6in (5.1m) was powered by a low-pressure forward directional only steam turbine producing 16,000 shaft-horse power at 165 revolutions per minute. Her power plants produced an output of 100 volts via four sets of 400-kilowatt dynamos creating 4,000 amps and a total combined capacity of 16,000 amps, collectively. Over 2,000 steel plates were used in her

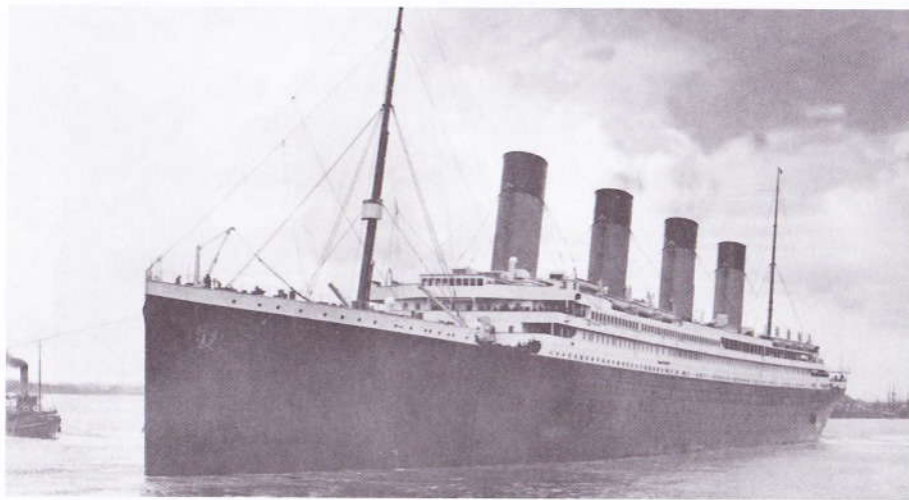

- 9 Titanic enters the waters of Southampton's River Test as she begins her maiden voyage, 10 April 1912.



- 10 Everything about Titanic showed what a titan she was. Her monster 15.5-ton center anchor is pictured here in April 1911 following testing at the anchor testing and certification facilities of Lloyds Proving House in Netherton, England. The following day it would take a team of twenty Clydesdale horses to haul this huge steel anchor from the Proving House to the railway station for its journey to continue via train then by cargo ship across the channel to Belfast, Northern Ireland.

construction and a staggering three million wrought iron rivets were driven into her hull both by hand and by hydraulic rivet machines were steel plates overlapped at the thickest point. She was a floating city of steel, wood and glass. She soon became a symbol of modern engineering and that of the greatest of the works of man.

Titanic was as beautiful inside as she was externally. Her luxurious interiors offered the best that money could buy with sweeping solid oak and wrought iron grand staircases topped off with elegant decorative domes. First Class passengers could dine in style in either the elegant Louis Seize period surroundings of the à la carte restaurant or the Jacobean splendour of the 532 seated Dining Saloon. Rich mahogany and mother-o-pearl inlays were to be found in the Smoking Room while the beautiful Louis Quinze style Lounge was inspired by the Palace at Versailles. For pleasure passengers could take in the sea air by either strolling along the boat deck or the enclosed 500ft long A-deck promenades that were screened off towards the bow for comfort or the open section towards the stern for those more eager to enjoy the gentle breeze blowing in off the sea could gather to talk about the news of the day. Beneath the second funnel on the boat deck passengers could gather to socialize or try their hand at the various appliances in the gymnasium; the rowing machines, exercise bicycles, ceiling mounted punch ball or the electric horses made to simulate riding a horse. Out on deck they could participate in deck games such as shuffleboard, deck quoits, sack races, egg and spoon races or the sets of swings attached to the awning bar on the rear mast. Other luxuries to be had was a plunge in the ships heated swimming bath, maybe a game or two in the squash court later followed by being pampered by stewards in the Turkish Bath and Cooling Rooms. Or just relax in a deck chair out on deck with book and a steward to bring you your favourite hot or cold beverage at your call. Second Class and Third Class were not left out. For Second Class passengers they could browse the books in the Adams style library or relax in the Louis XVI smoking room and dine in the 17th century period styling of the dining room. Out on deck they had two areas of spacious promenades from that of the aft end of the boat deck or the enclosed section of promenade on C-deck. Third Class on Olympic and Titanic was a great improvement compared to other passenger liners of the time. With ales and stout on tap along with bottled beers a lively time could be had any time of the day or night as passengers could make their own entertainment in the general room or smoking room with music and songs from instruments they brought on board themselves or take to the upright Steinway piano that graced the room. Out on deck Third Class had plenty of deck space on offer from the forward and aft well decks to the raised poop deck on the stern that gave an almost uninterrupted view out to sea. When fully accommodated Titanic could carry 2,435 passengers and a crew of 892.

Titanic went ahead with her sea trials on Tuesday 2 April 1912 and having completed them in less than a day she was certificated and approved by the Board of Trade to be handed over to her owners. Later that day she left Belfast for the last time and steamed to Southampton where she arrived just after midnight on the 4 April. The days to follow would see the new liner made ready for her maiden voyage, which came on Wednesday 10 April at 12:15 P.M. The liner made her way down Southampton

waters, out into the English Channel to arrive in the Grande Rade of Cherbourg harbour at 6:30 P.M. that evening where the two White Star Line tenders *Nomadic* and *Traffic* transported passengers and mails from the quayside out to the new liner. At 8 P.M. Titanic was now steaming away from the French coastline for her overnight journey to Queenstown, renamed as Cobh in 1920, on the south coast of County Cork, Ireland. Titanic arrived in Ireland at 11:30 A.M. on the 11 April where she dropped anchor off Roches Point lighthouse to await the passengers tenders. Following the exchange of mails and embarking and disembarking passengers Titanic weighed anchor for the last time and turned her bows away from the Irish coast at 1:40 P.M. and headed out past the headlands of the Irish coast and out into the cold waters of the Celtic Sea. Beyond lay the relentless waters of the North Atlantic Ocean. Her final port of call was New York some 2,700 nautical miles away where Titanic was due to arrive at the White Star Line Pier 59 during the early morning hours of Wednesday 17 April. On board were a total of 2,208 passengers and crew.

Three days later on the night of Sunday 14 April Titanic was met with disaster when she side swiped a huge North Atlantic iceberg that bulked plates, popped rivets and opened up seams in the hull resulting in five of her watertight compartments becoming compromised. Two-hours and forty-minutes later the "unsinkable" Titanic had gone down claiming the lives of 1,496 men, women and children in what would become the most tragic disasters at sea in maritime history. Her sinking created a turning point in Edwardian society as social divides came under scrutiny. Shipping companies and their owners were forced to update their safety equipment including the British Board of Trade reviewing their regulations on lifeboats which at the time of the sinking of Titanic was nearly five decades out of date. From the loss of Titanic also came many changes in safety at sea including more lifeboats with more than enough capacity for every person on board. And a year later in 1913 the International Ice Patrol was conceived to watch over icebergs and ice flows that drift into shipping lanes that could become another threat to shipping. From the seeds of disaster there grew a phenomenon as the story of Titanic gripped the public's fascination. Her tragic demise would be put to the big screen as Hollywood gave the disaster a cinematic retelling that captivated audiences of all ages. Then in 1985 Titanic fever gripped the world again with the startling news that her shattered and twisted remains had been discovered on the 1 September resting 12,460ft down on the bottom of the dark and crushing depths of the North Atlantic. In March 1912 Titanic was the marvel of Edwardian engineering. She was validation of man's dominance in engineering wonders. Weeks later she became validation of man's arrogance over Mother Nature. Her sinking and discovery sent shock waves around the world but yet it was nothing but a ripple in the waters of time. Now in the 21st century the legacy of Titanic is as strong as ever as her epic story continues to fascinate generations from the young to the old. She was built as the last word in luxury. She was a marvel of Edwardian society, of Edwardian craftsmanship. She was the greatest of the works of man and she will always forever be the most famous and most loved ship in the world. She is the R.M.S. Titanic.

部品图 Parts

《船体》
Hull

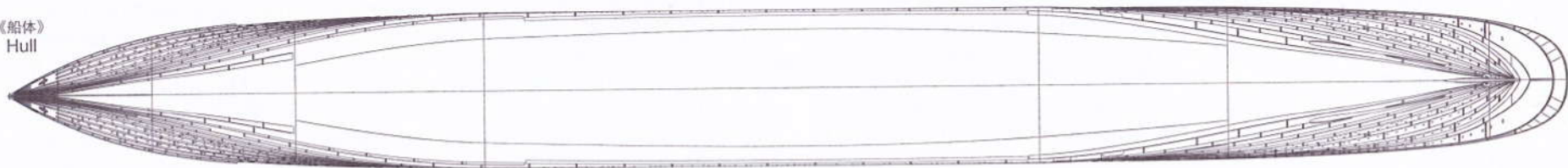

《甲板 W1》
Deck W1

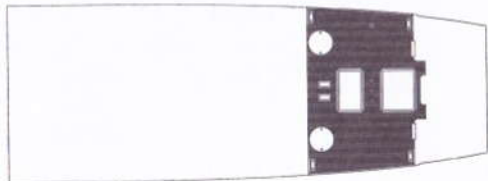

《甲板 W2》
Deck W2

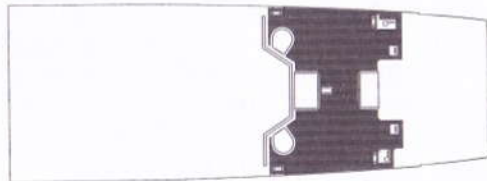

《舰桥 T1》
Bridge T1

《舰桥 T1》
Bridge T1

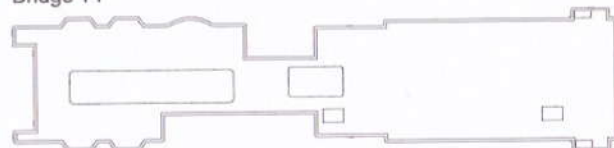

《甲板 Q1》
Deck Q1

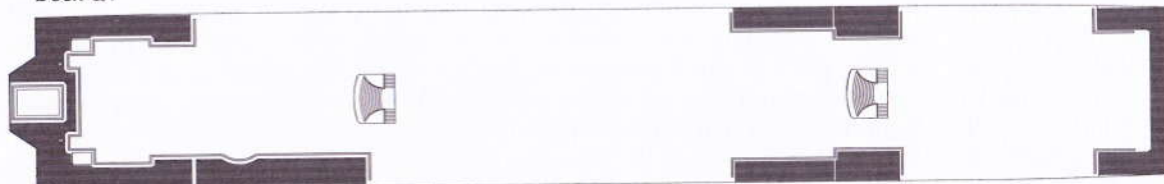

《舰桥 U1》
Bridge U1

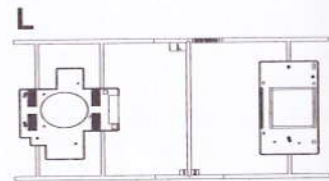
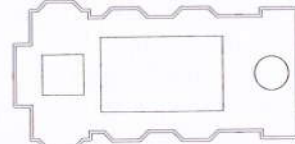

《甲板 R1》
Deck R1

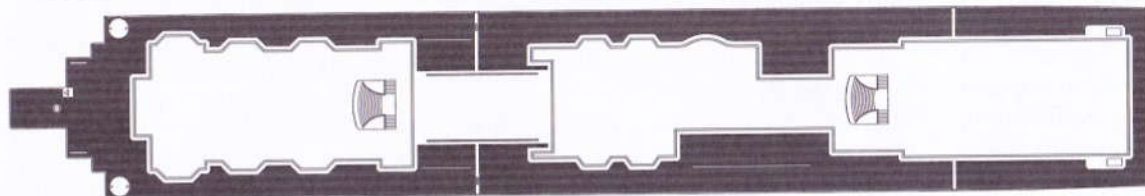

《舰桥 V1》
Bridge V1

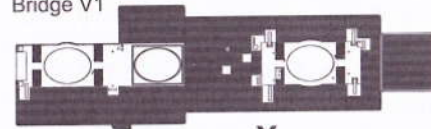

C1 C2 X1×2

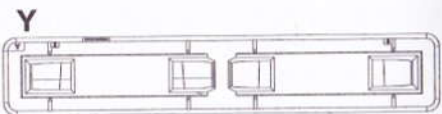

《甲板 S1》
Deck S1

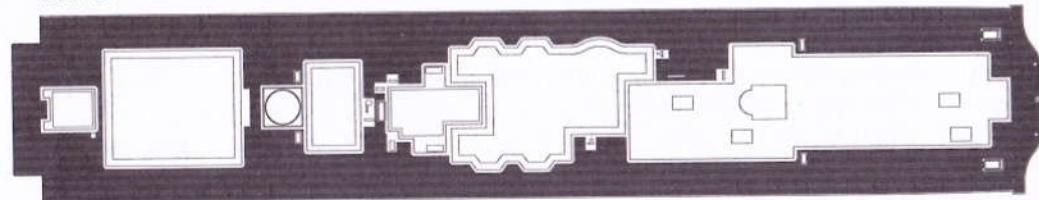

《座架》
Stand

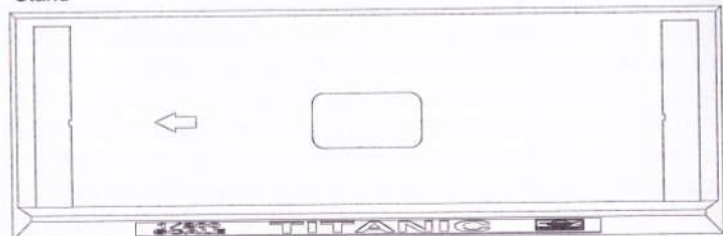

部品图 Parts

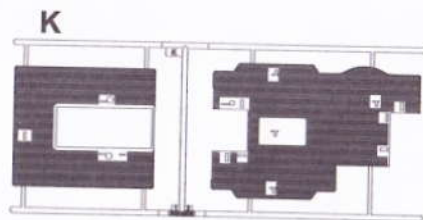
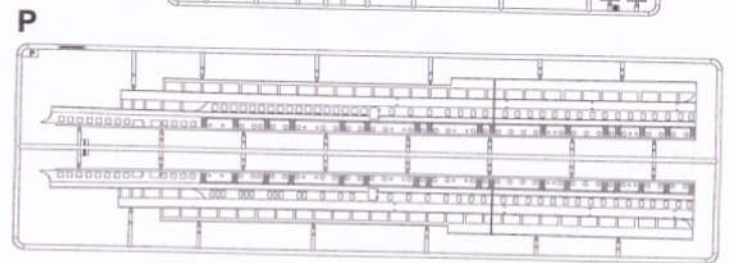
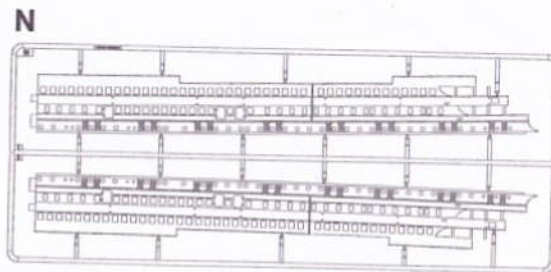
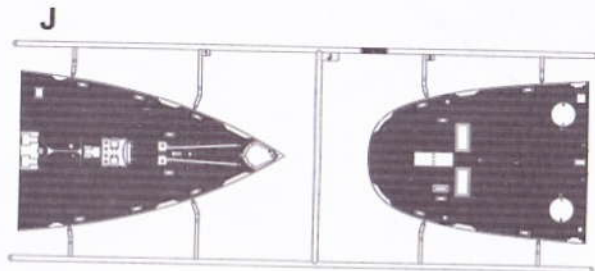
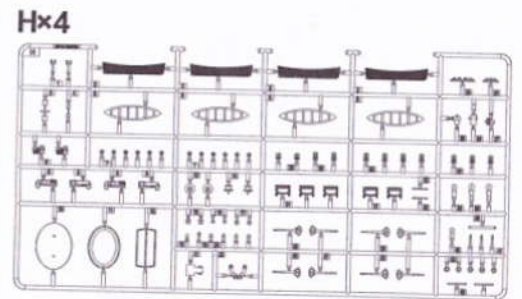
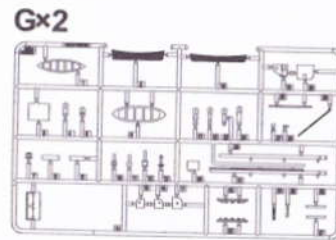
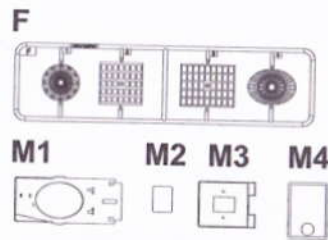
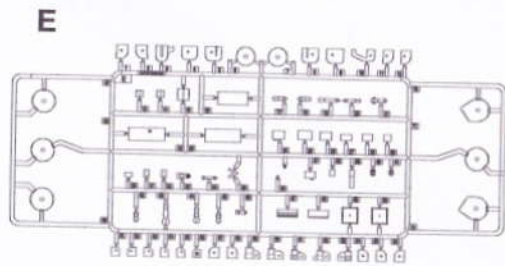
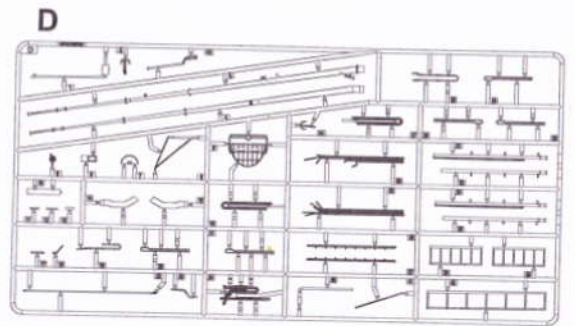
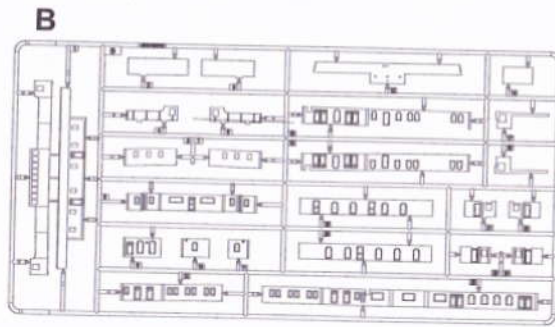
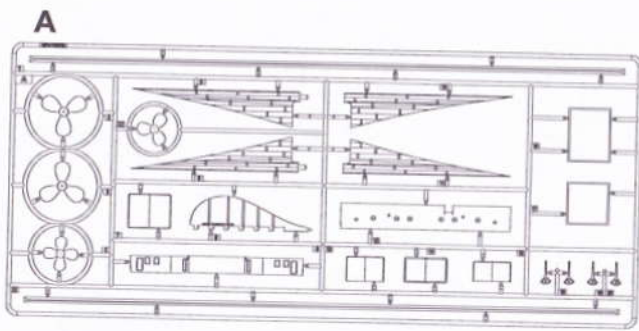

《蚀刻片》-A
PE-A

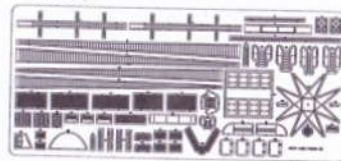

《蚀刻片》-B
PE-B

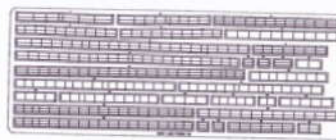

《蚀刻片》-C
PE-C



《水贴》
Decal

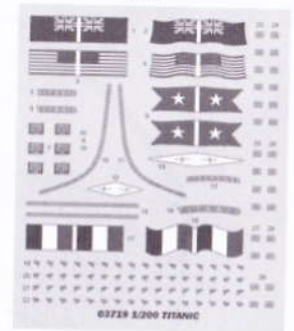

《链条》长: 200
Chain



《蚀刻片》-D x4
PE-Dx4

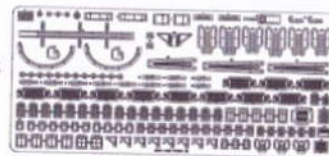

1

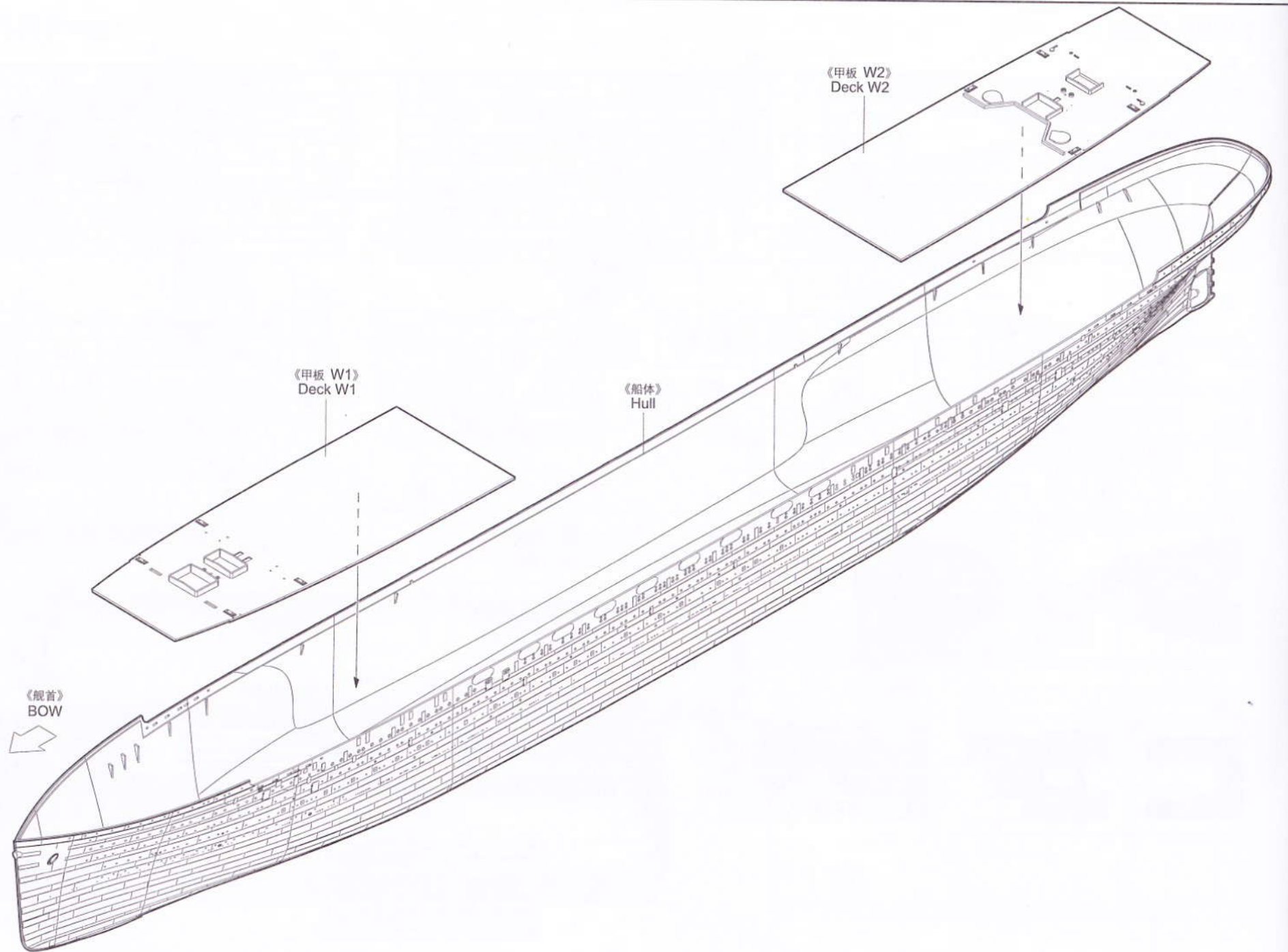

2

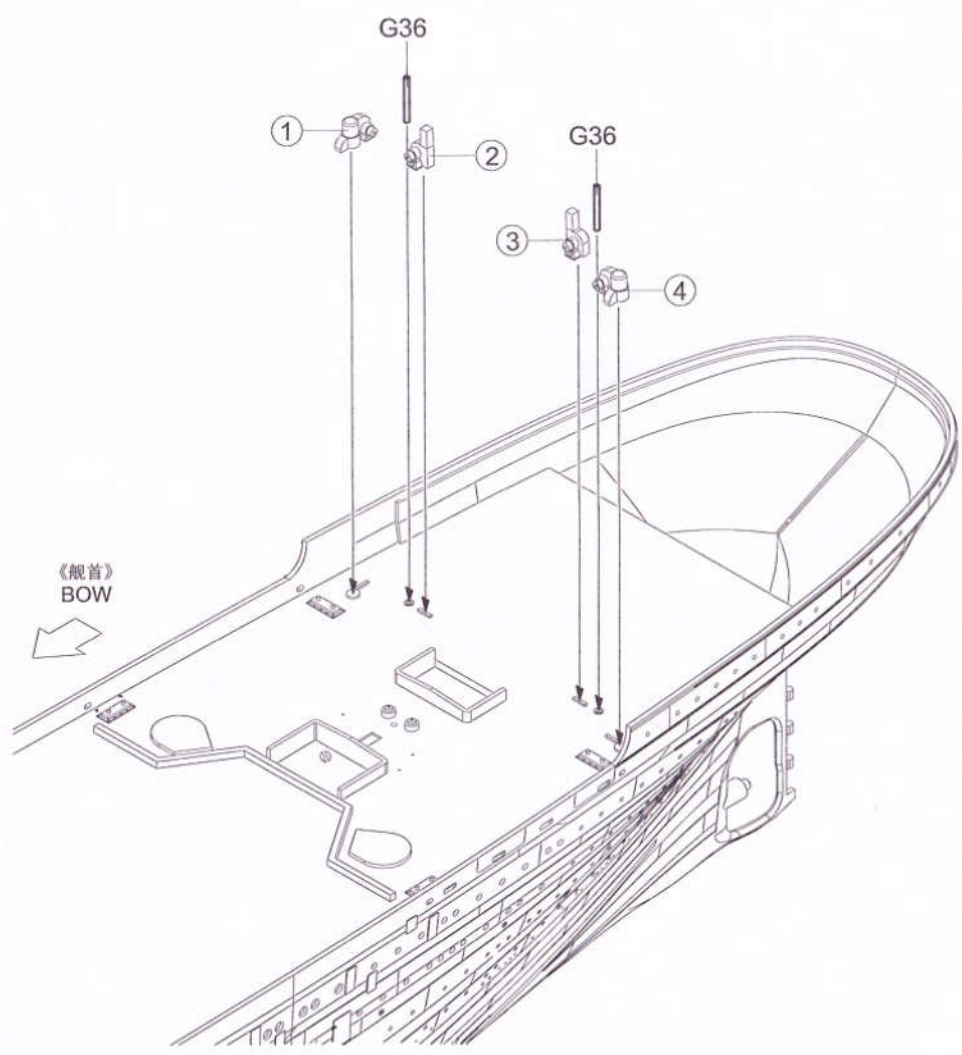
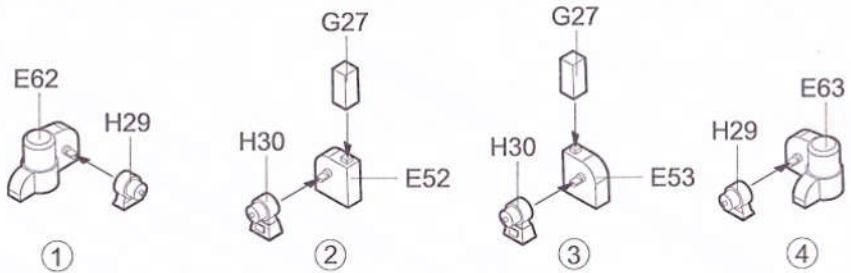

3

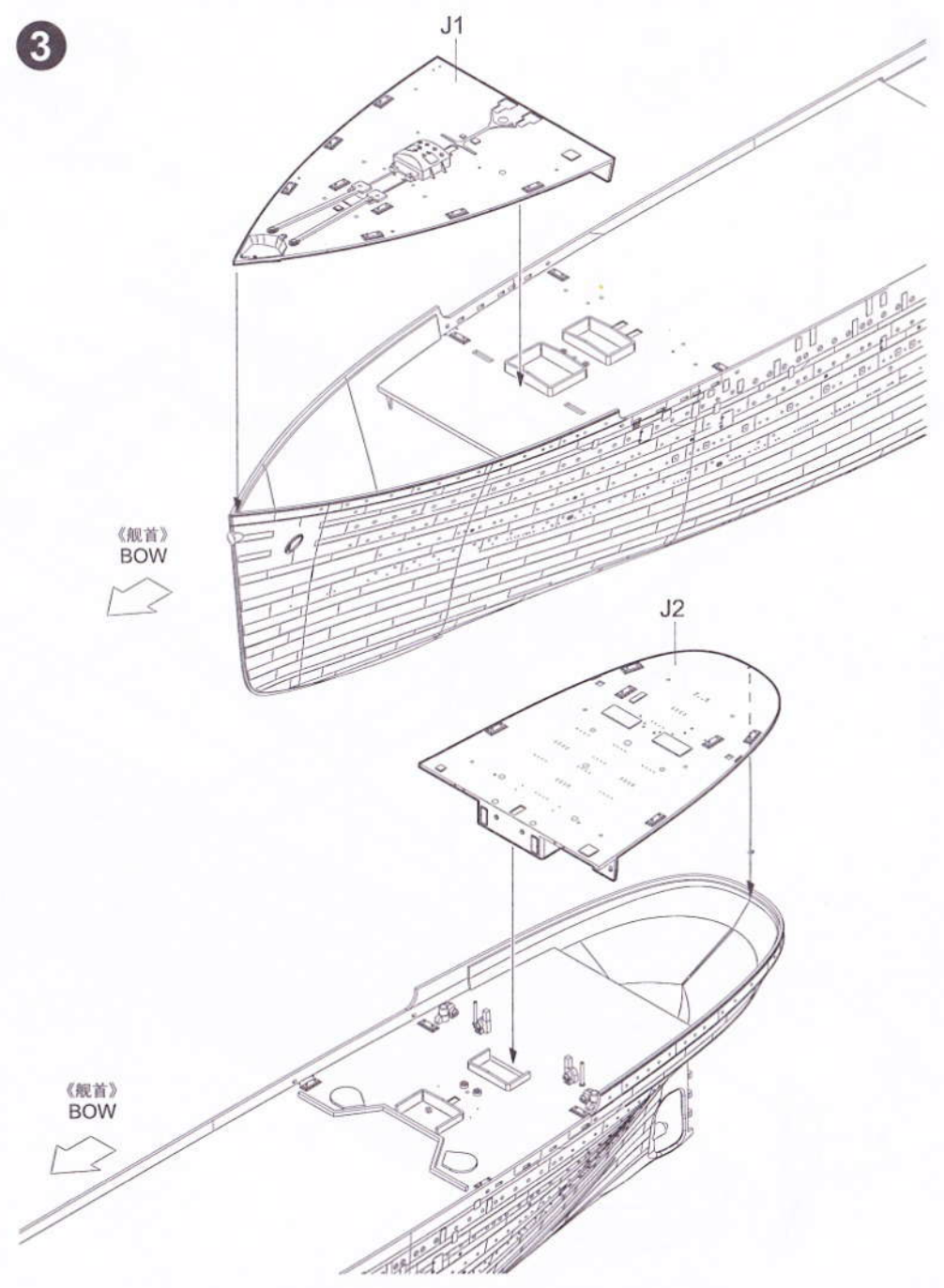

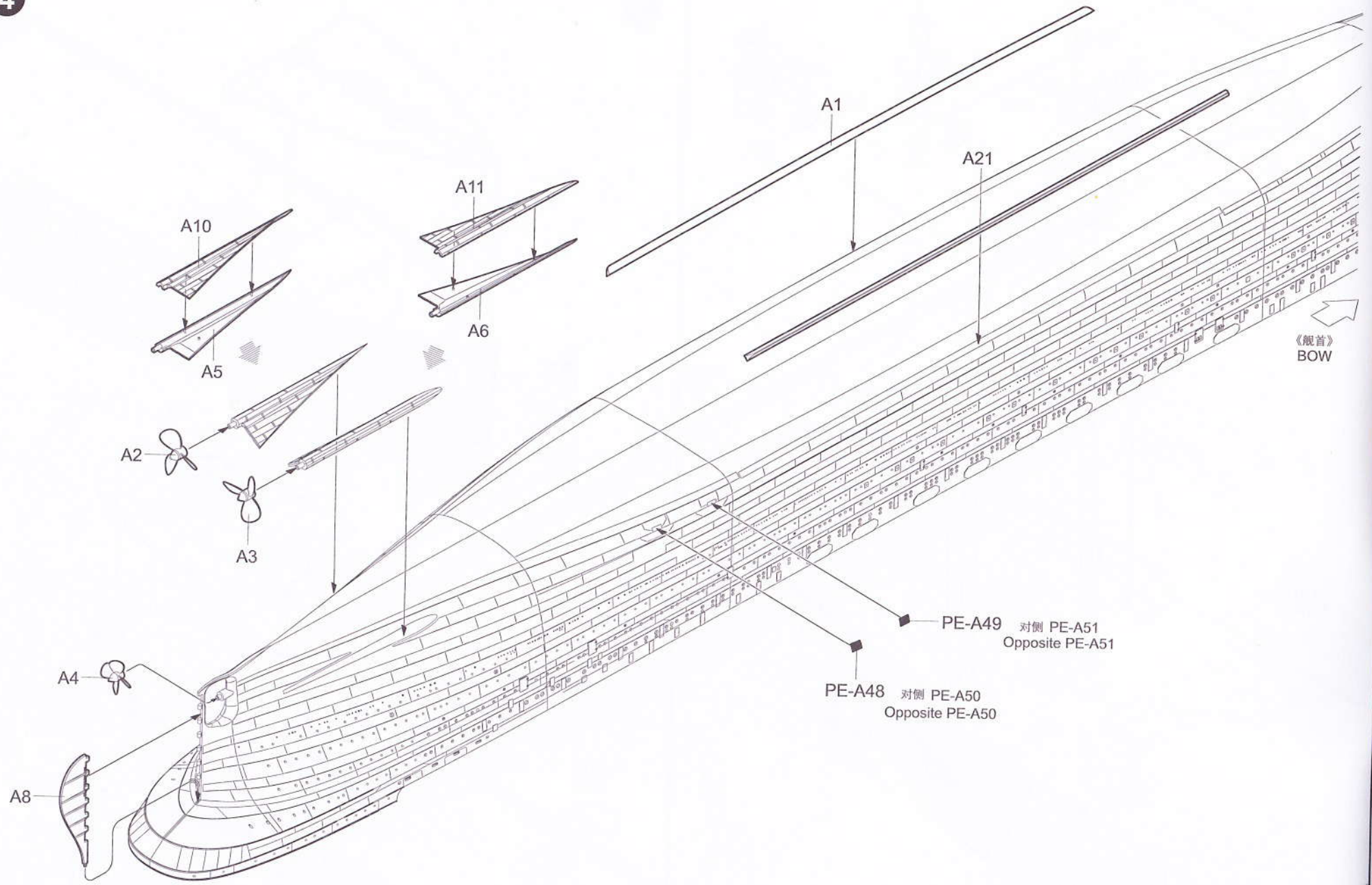

5

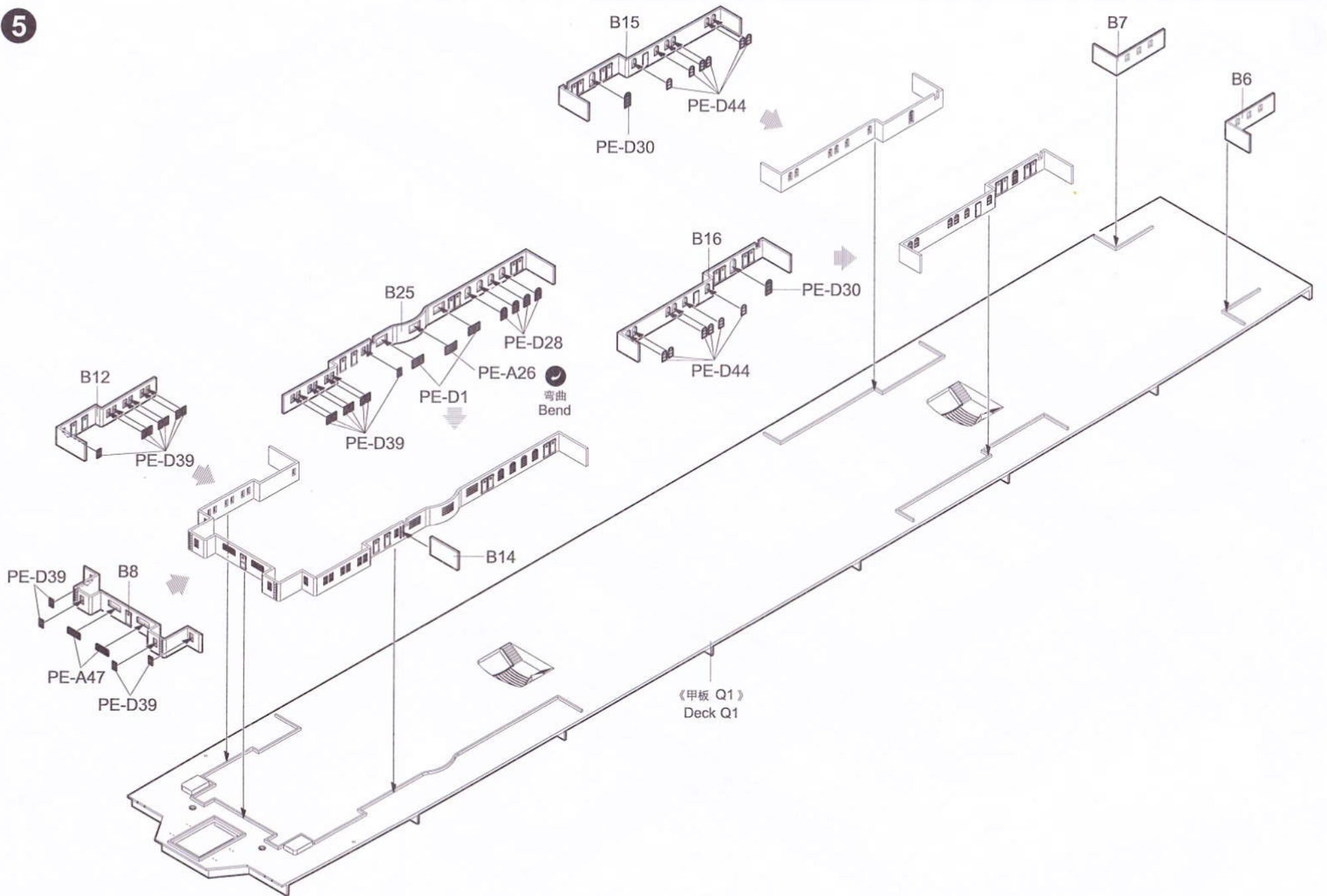

9

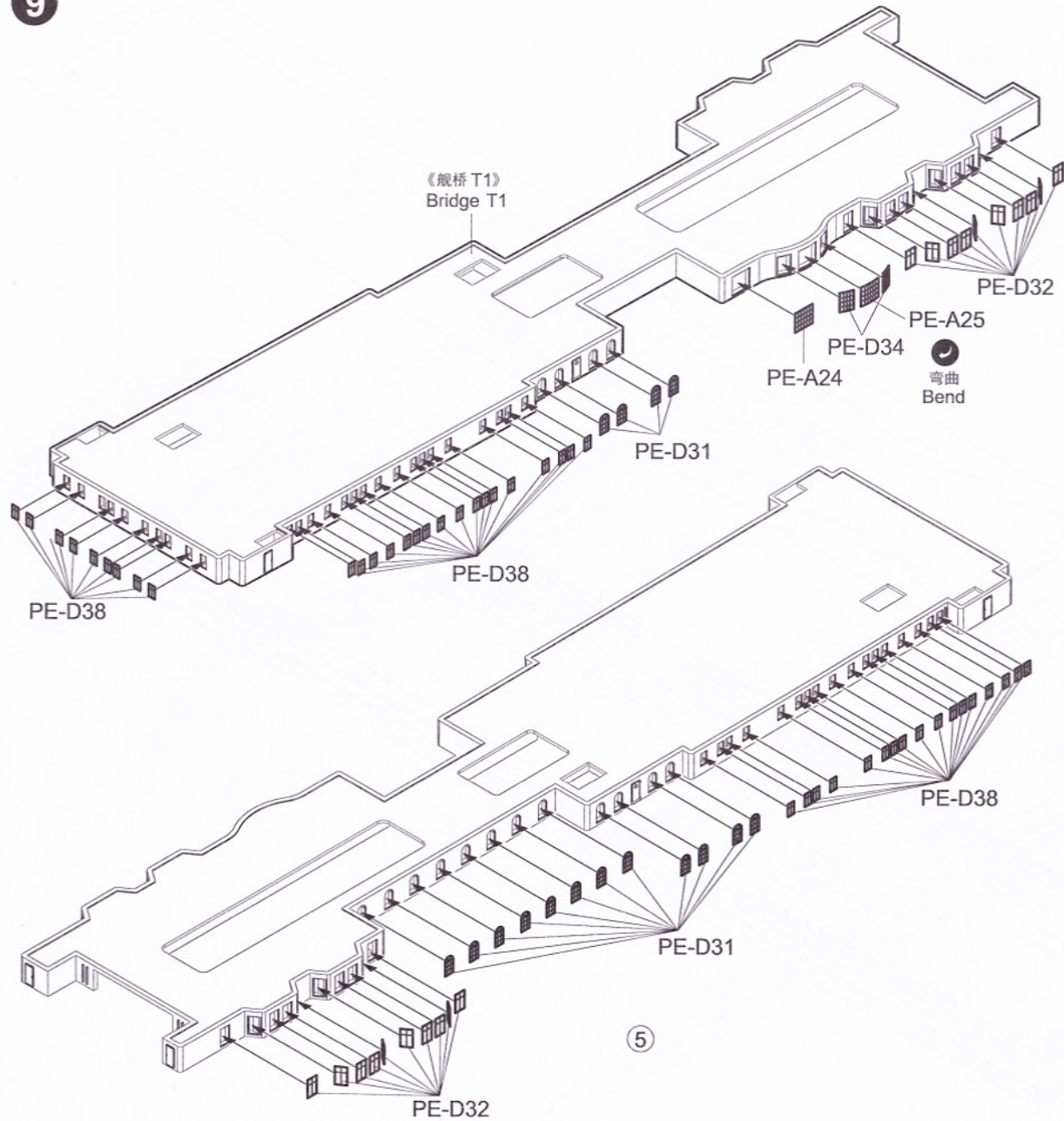

10

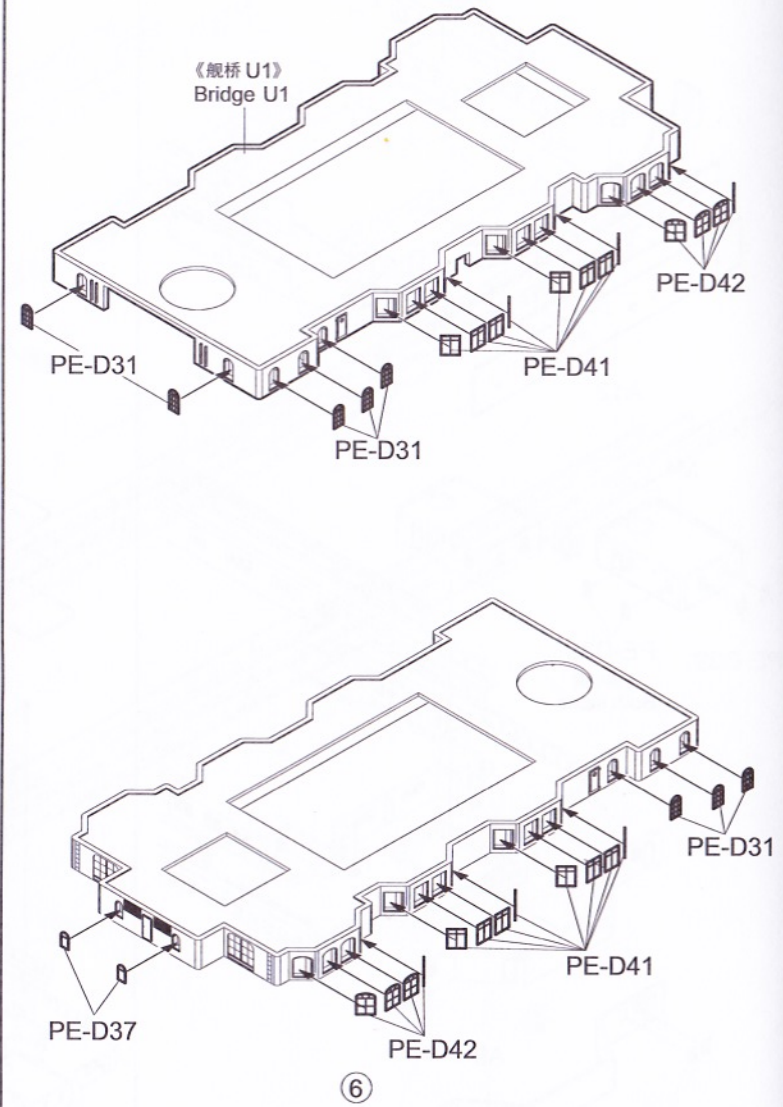

7

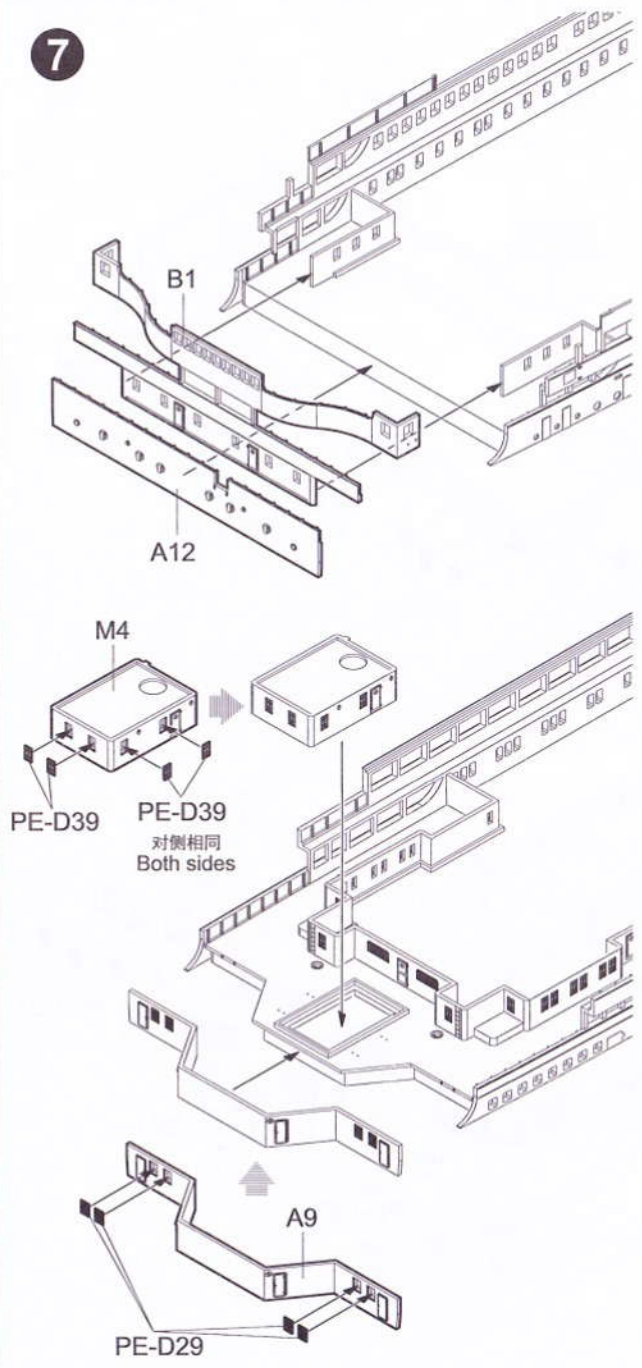

8

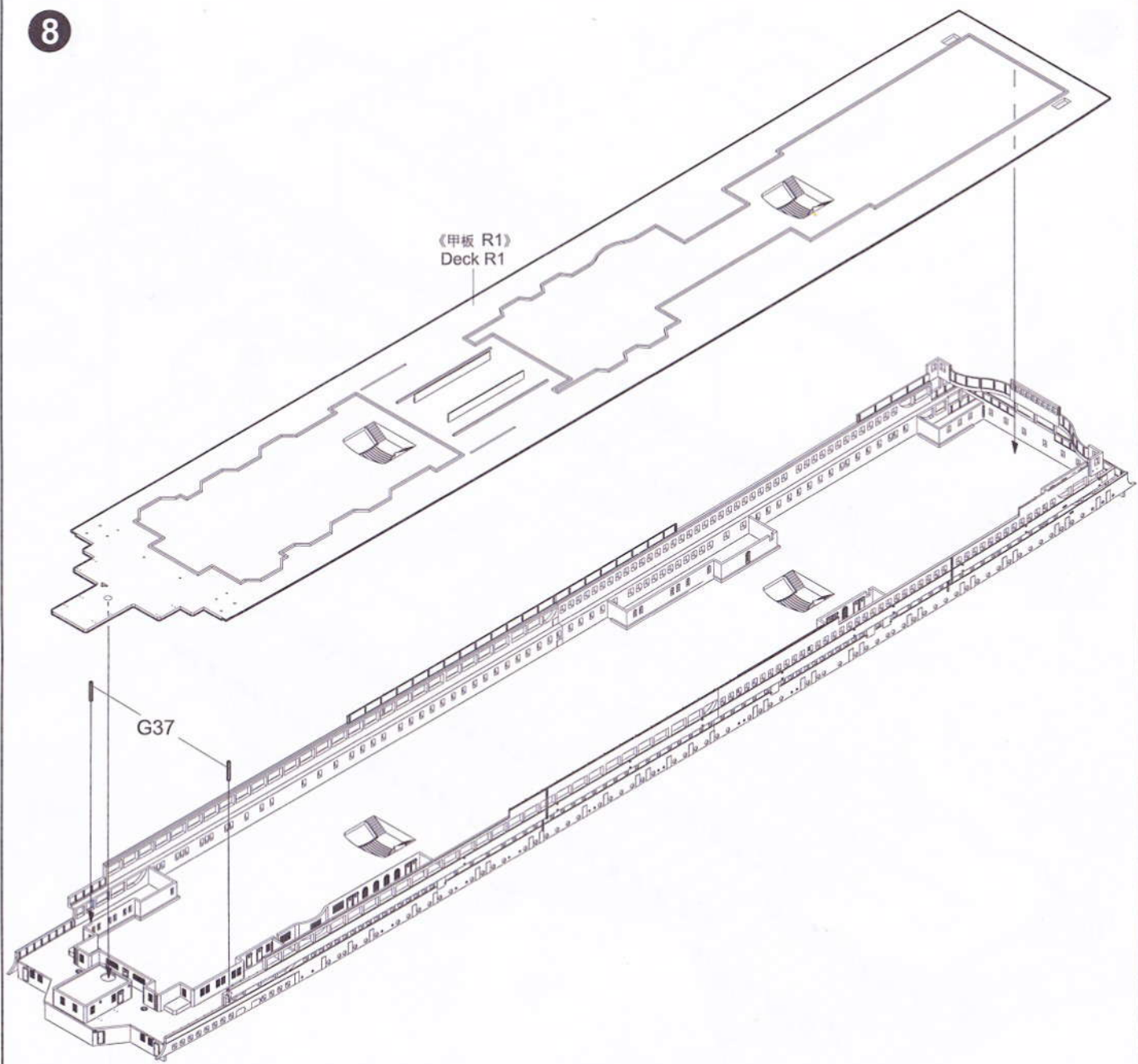

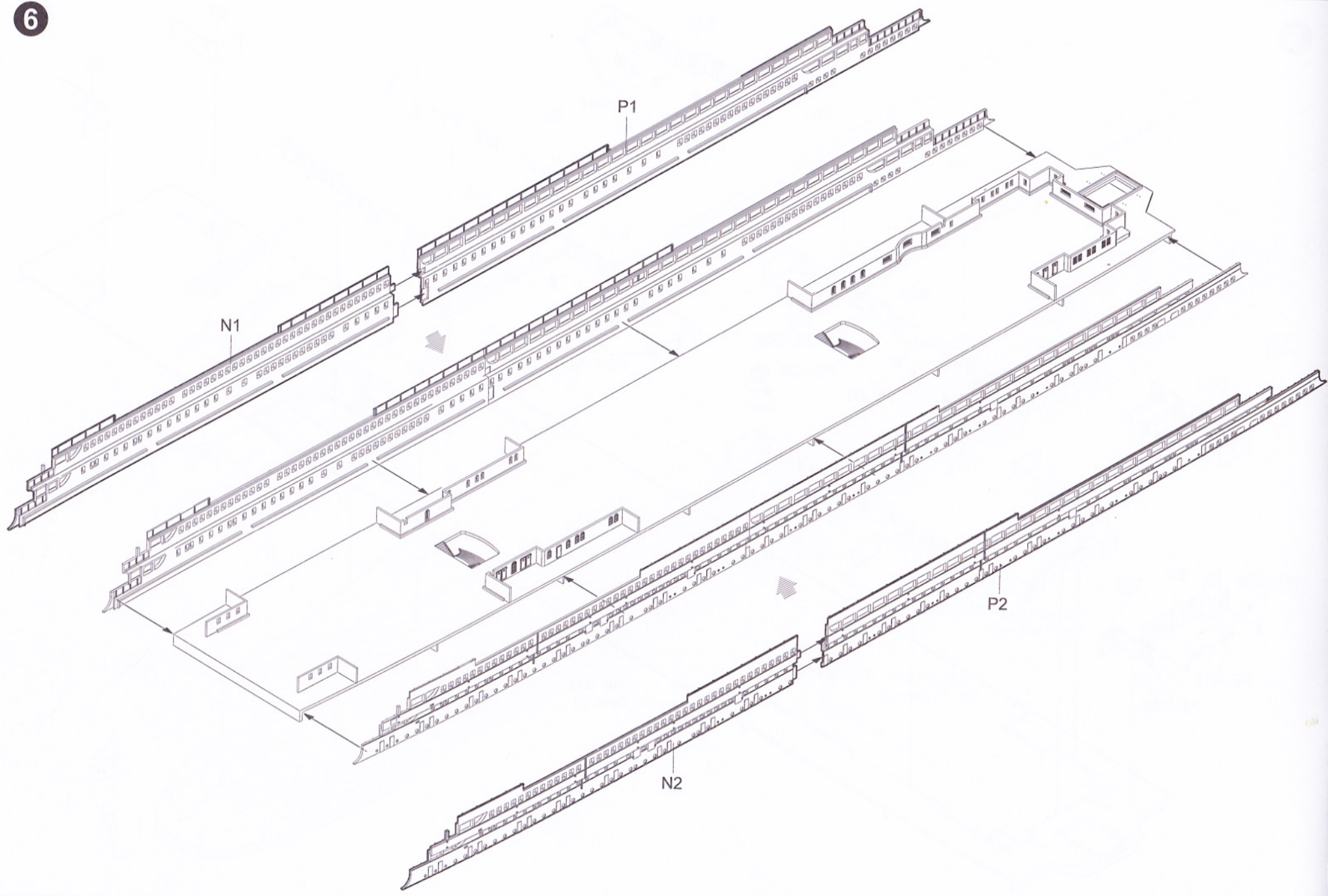

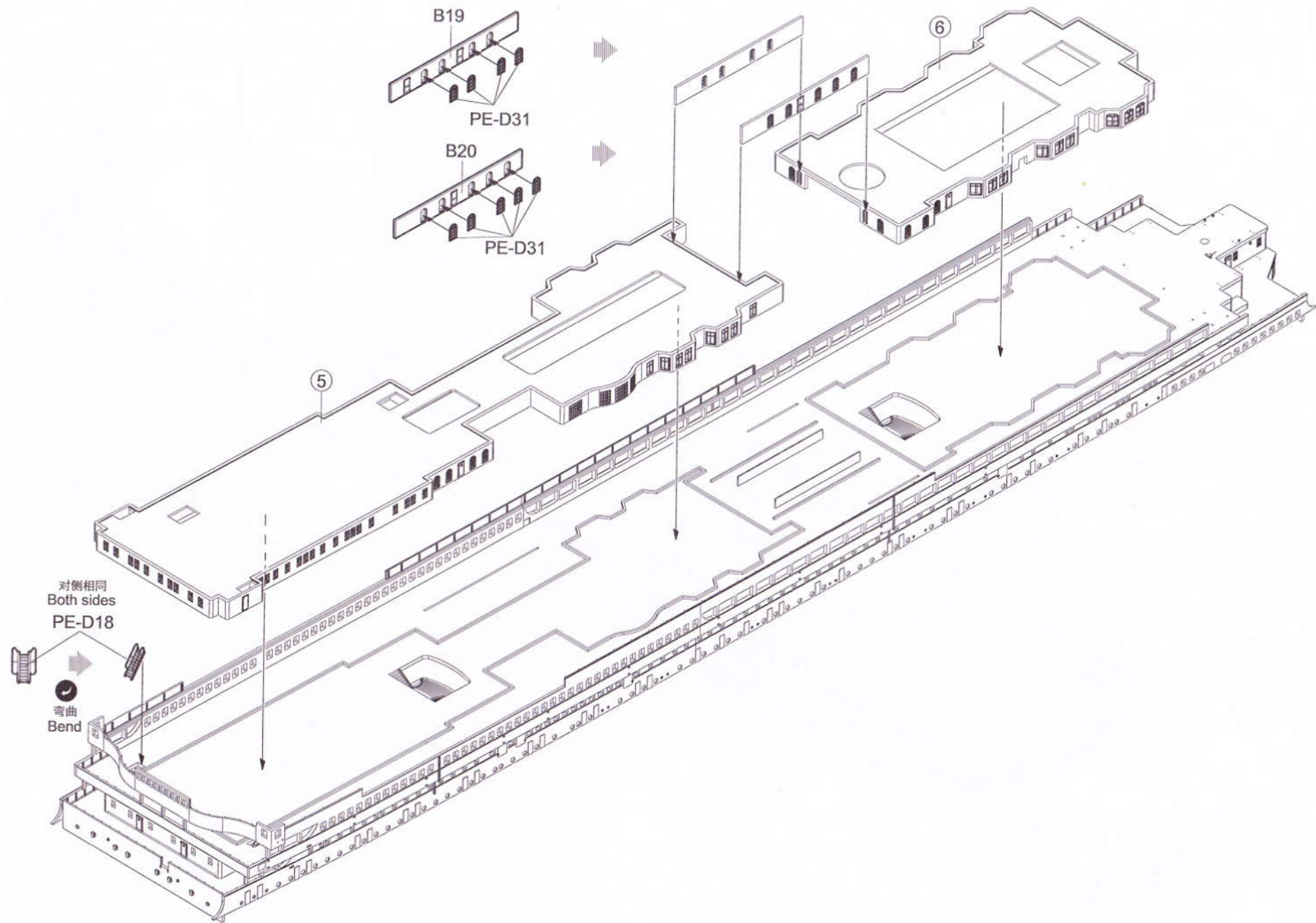

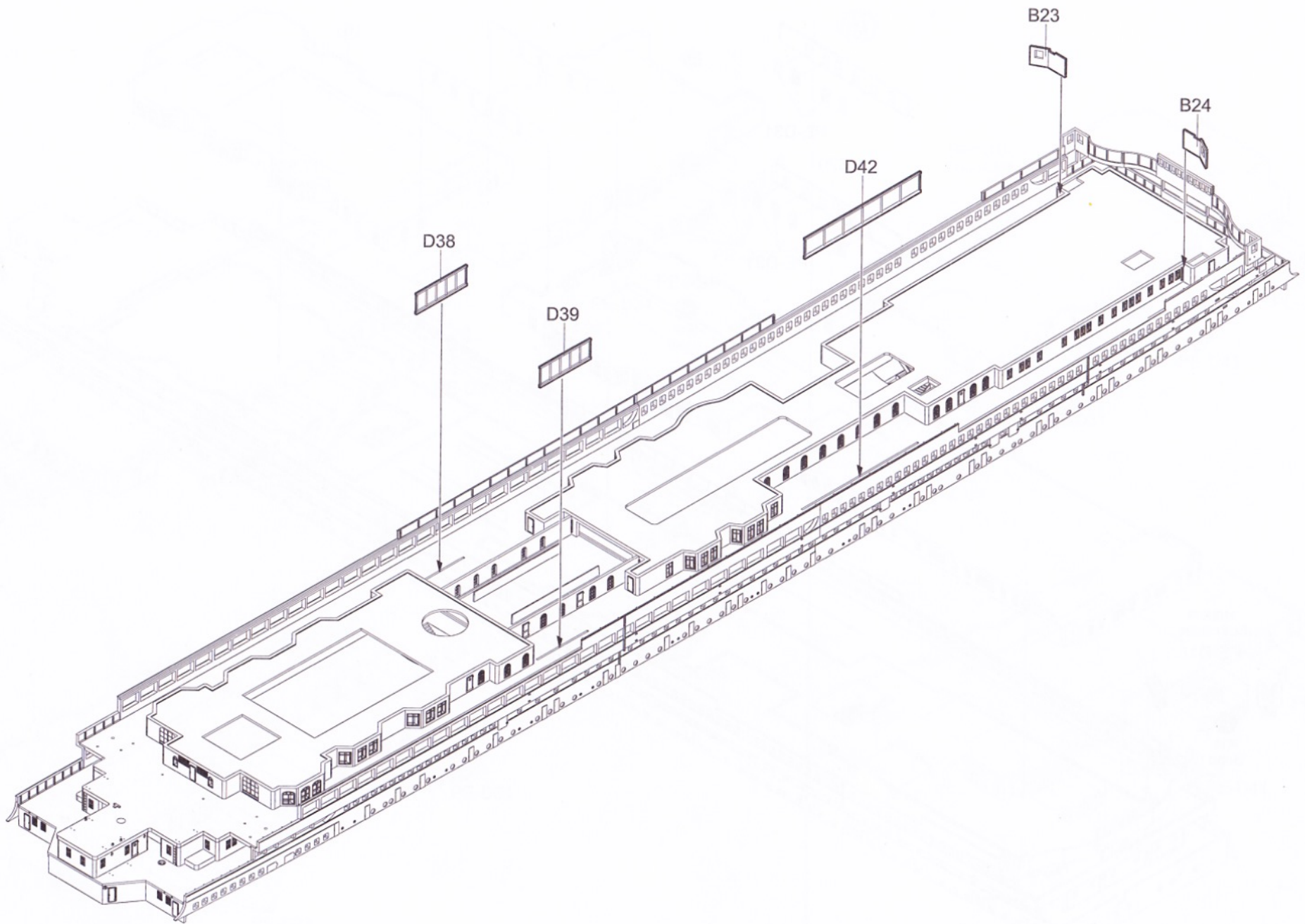

13

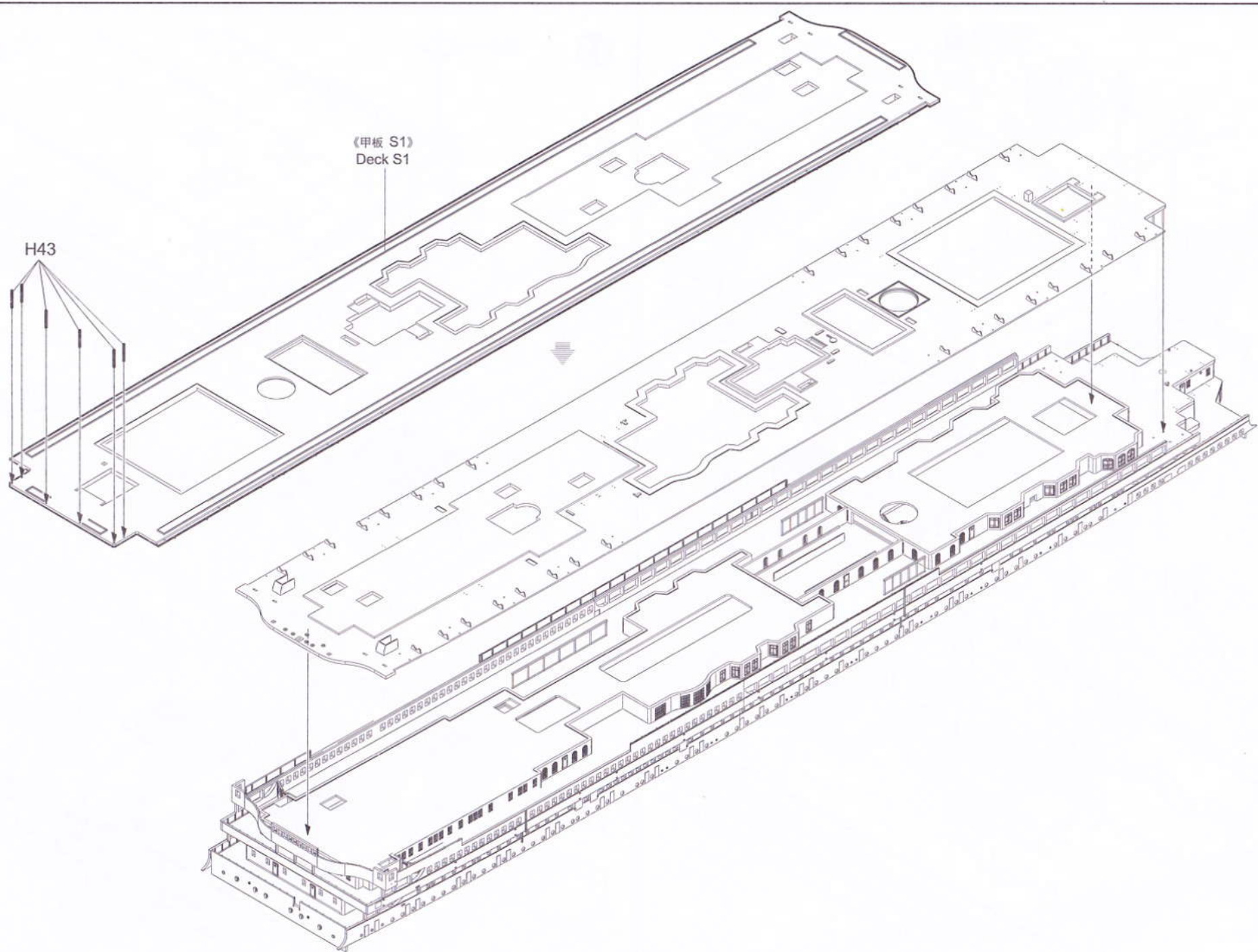

14

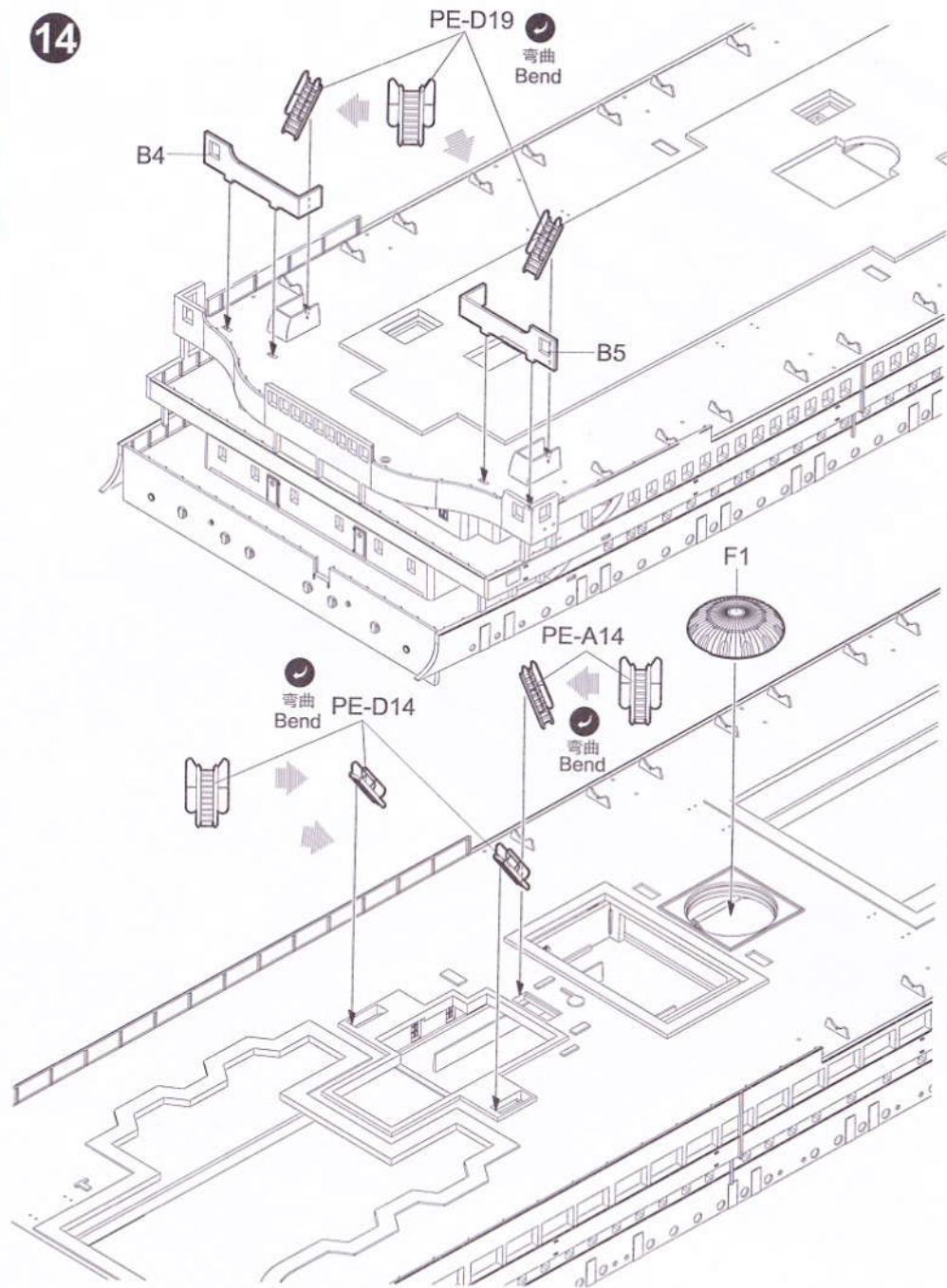

03719

15

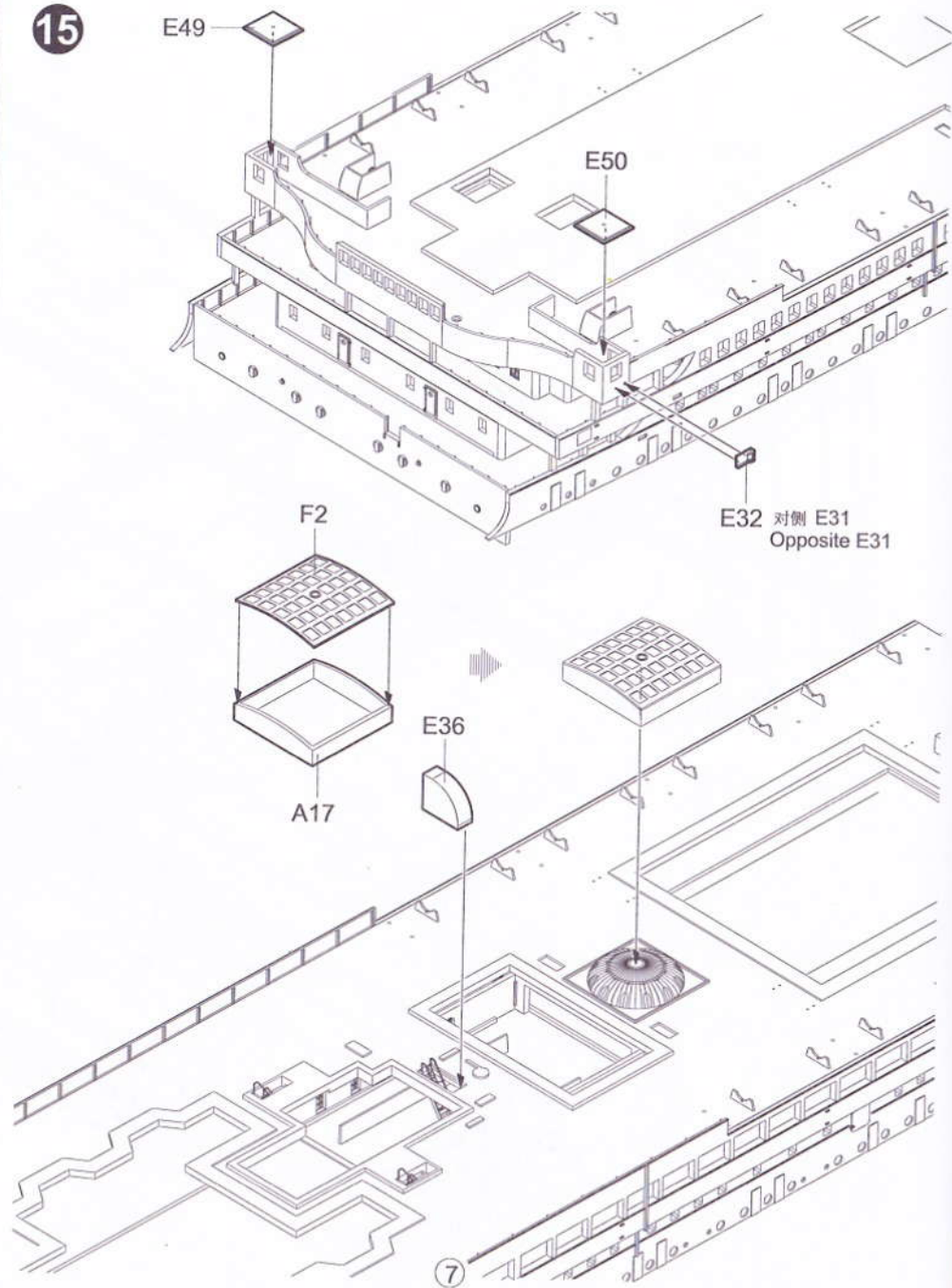

18

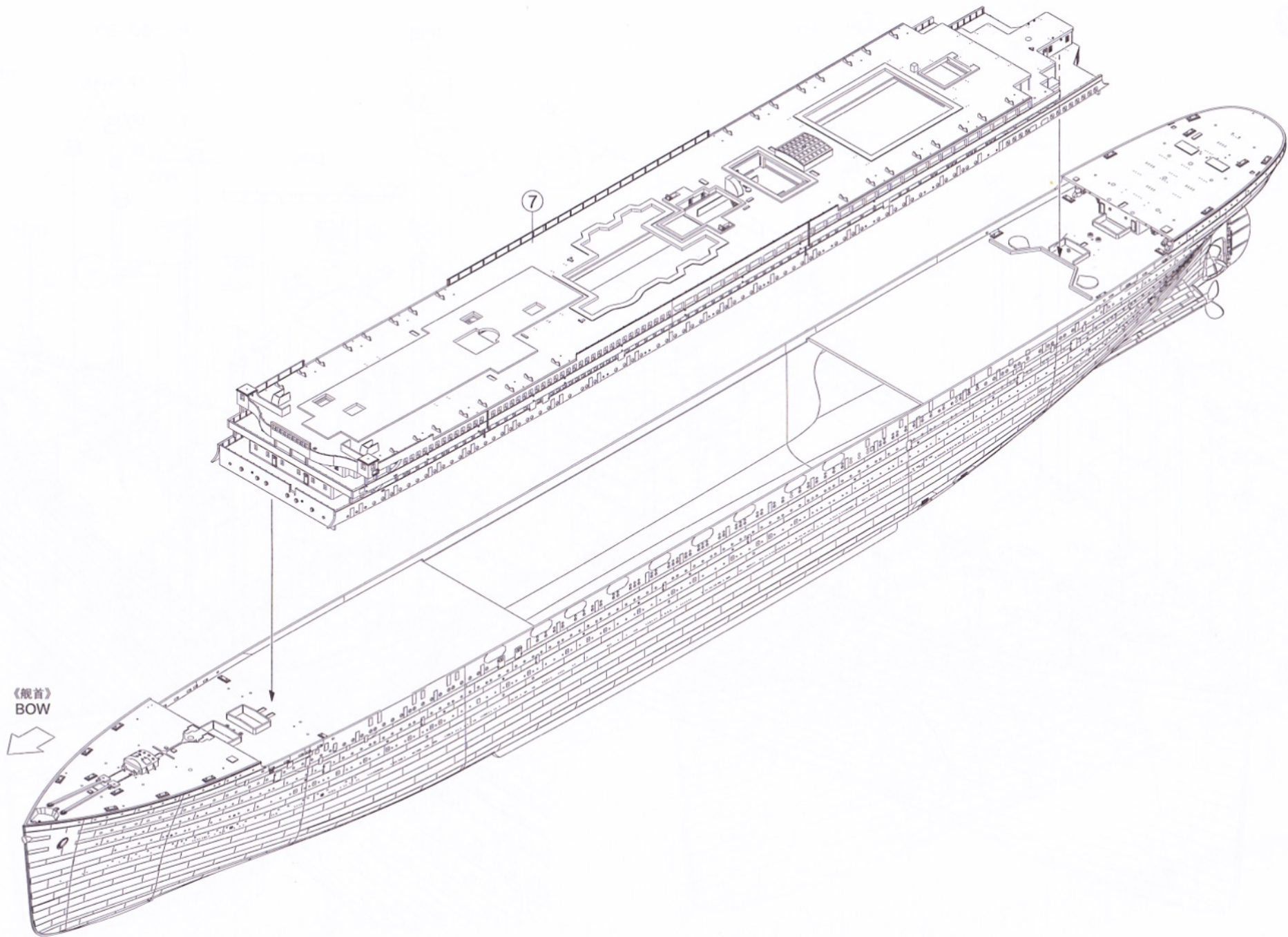

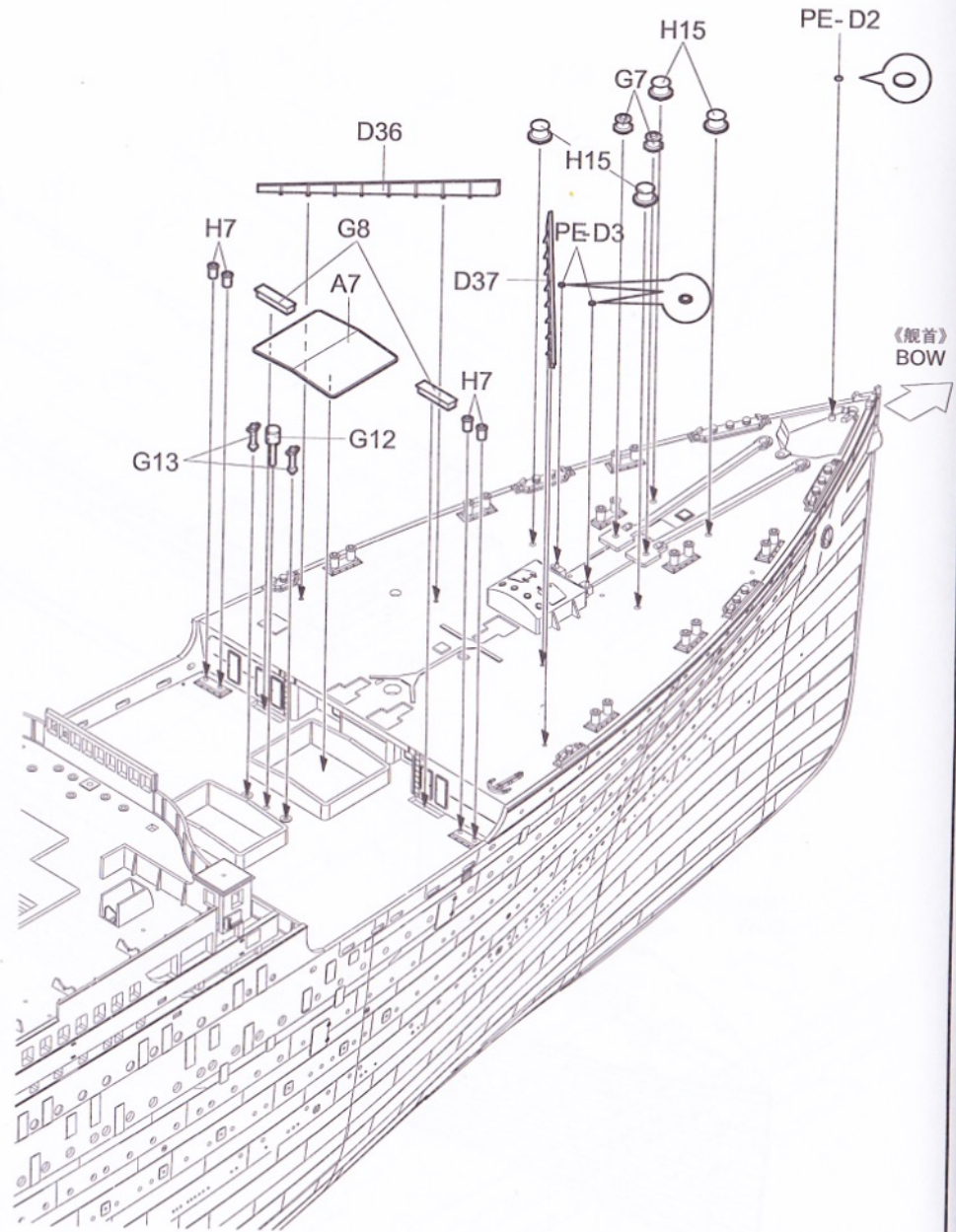
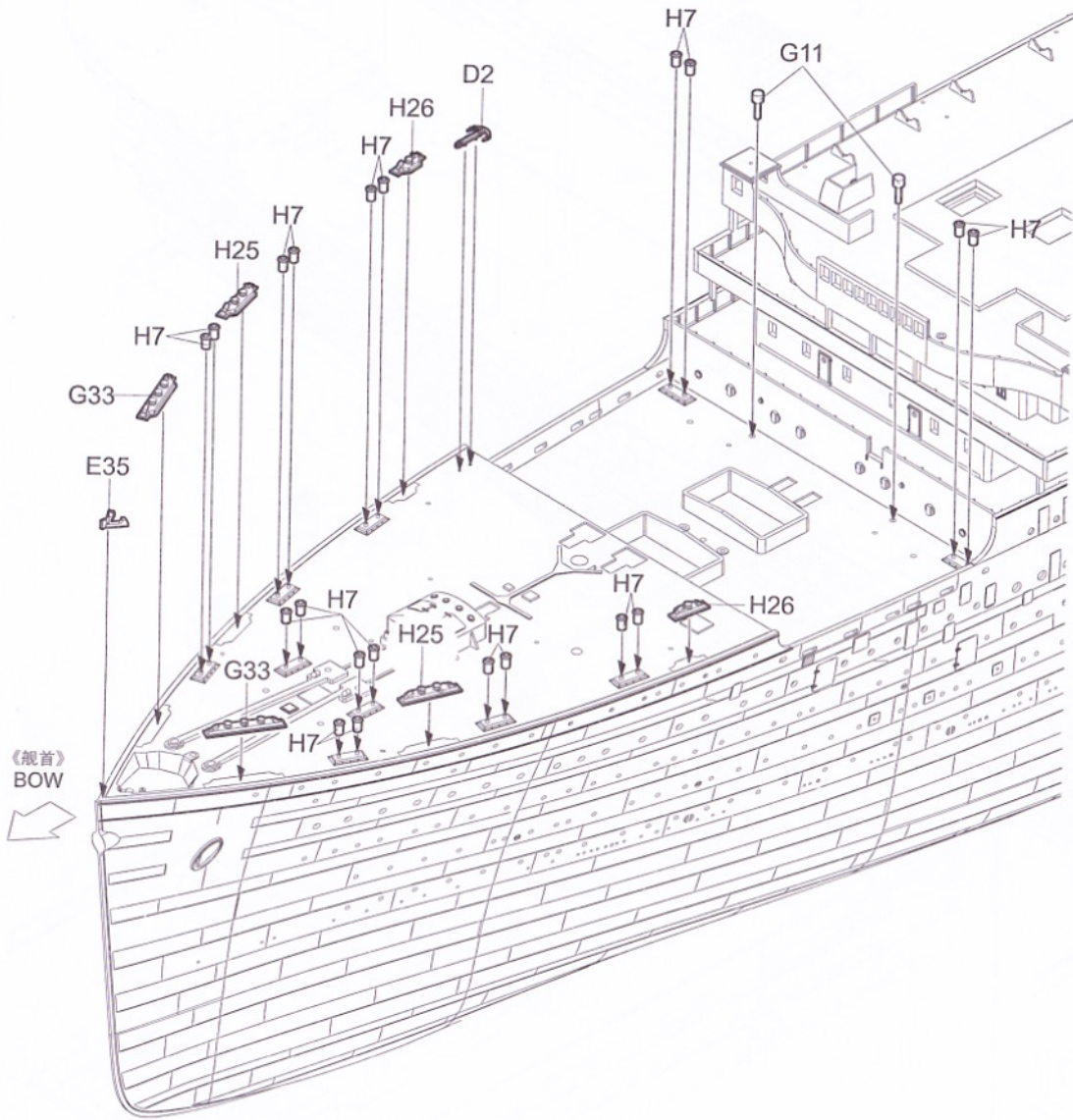

18

PE-D3
H41
⑧
制作8组
Make eight

H24 H20
H39
制作3组
Make three

《锚链》
Chain

PE-A22
A14
E69
E67
E38
E13
E44

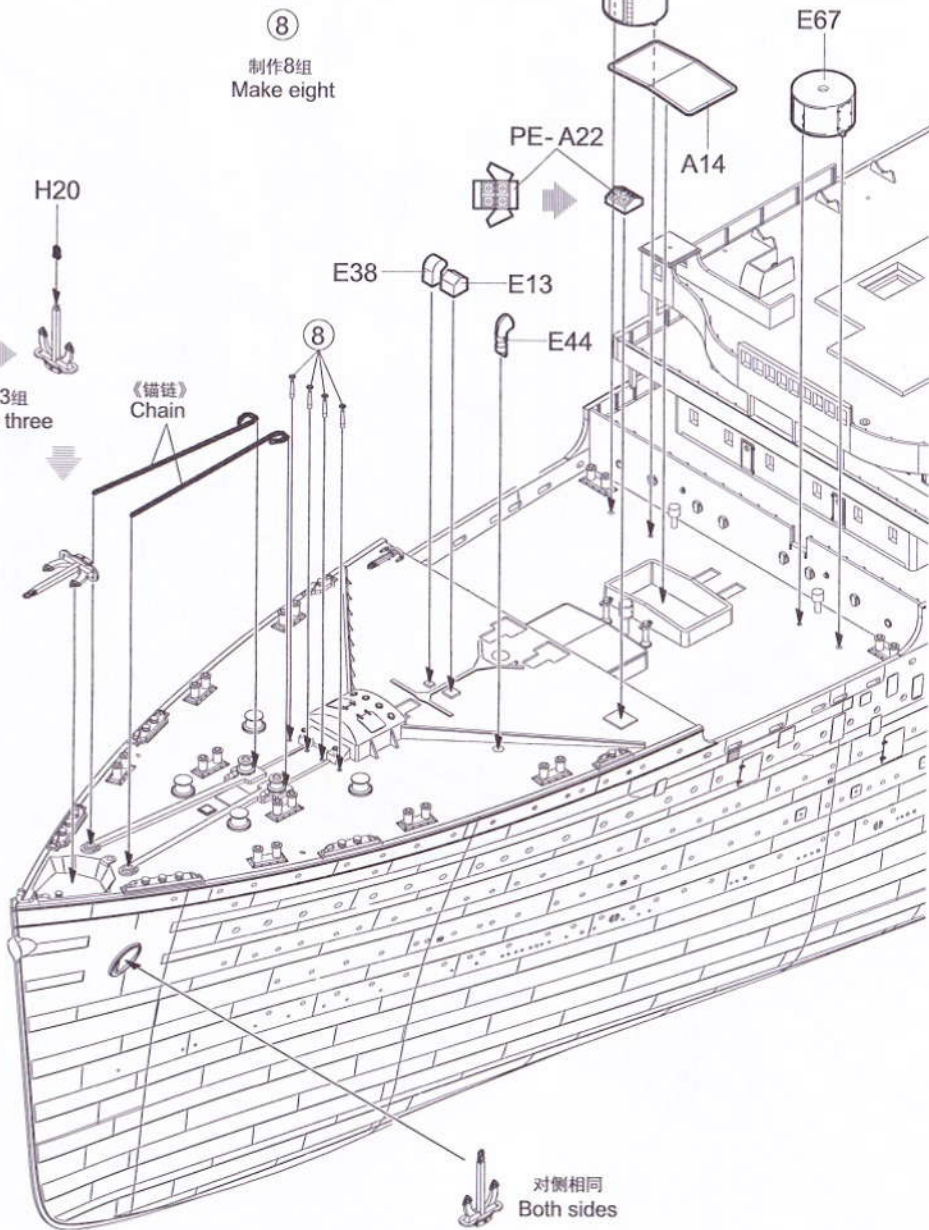

对侧相同
Both sides

H4 H3
H27
⑨
制作3组
Make three

H21
H6
⑩
制作8组
Make eight

G26
PE-A52
D8

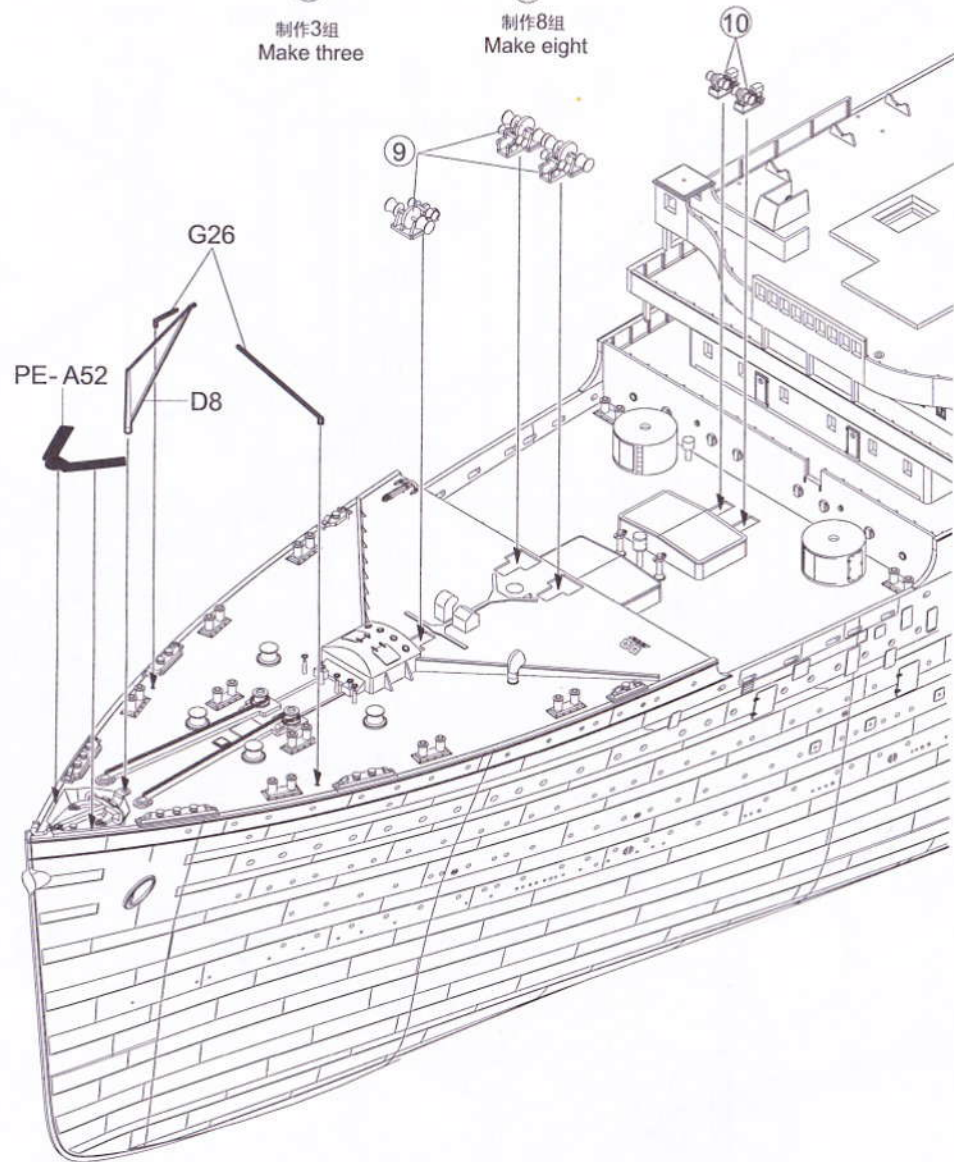

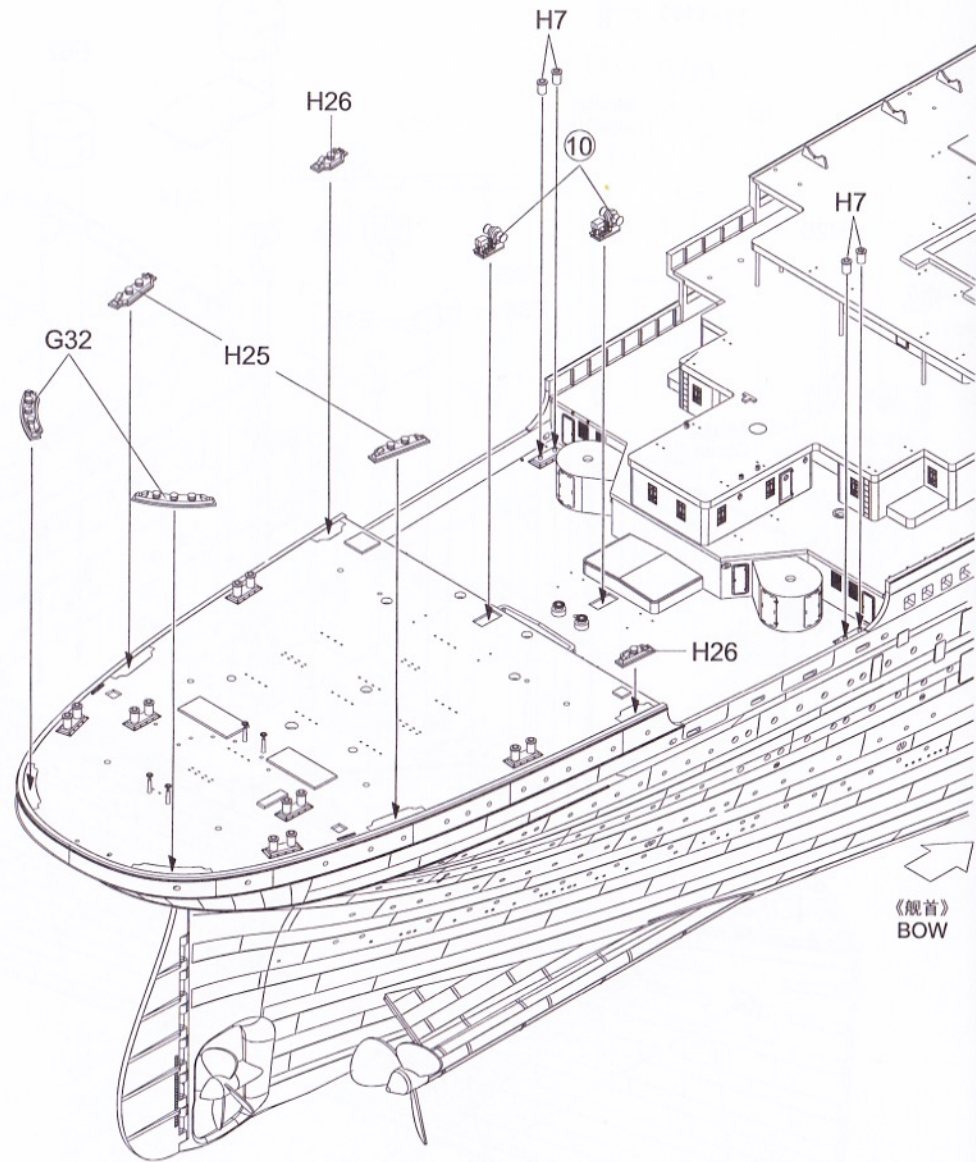
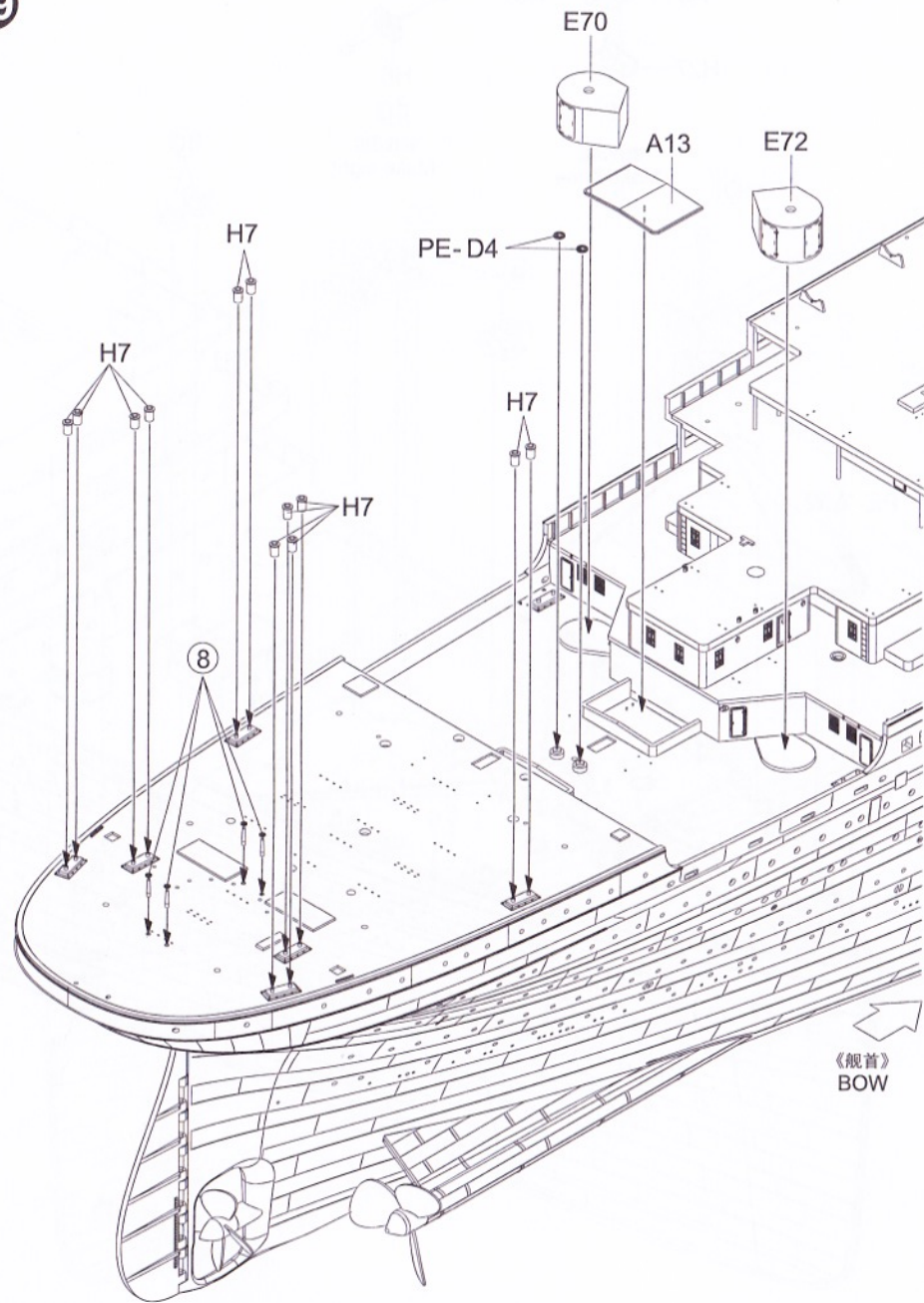

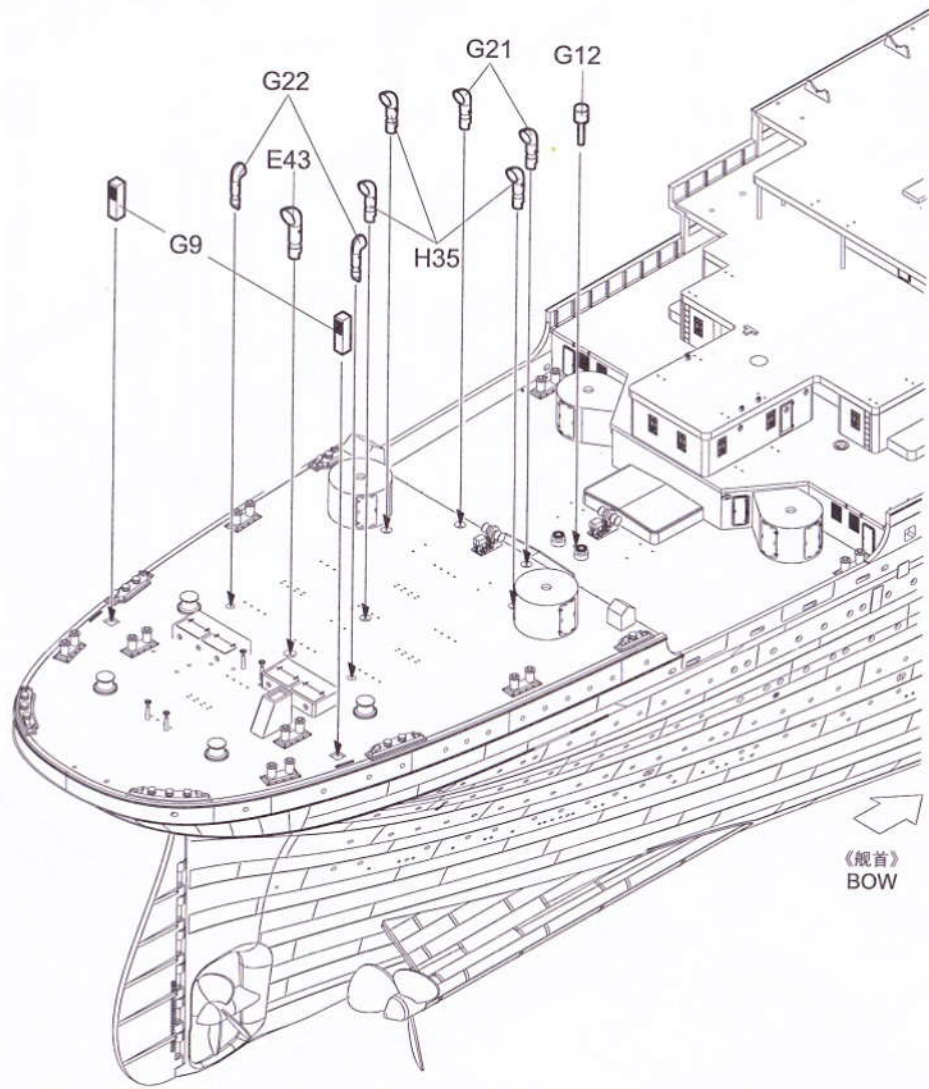
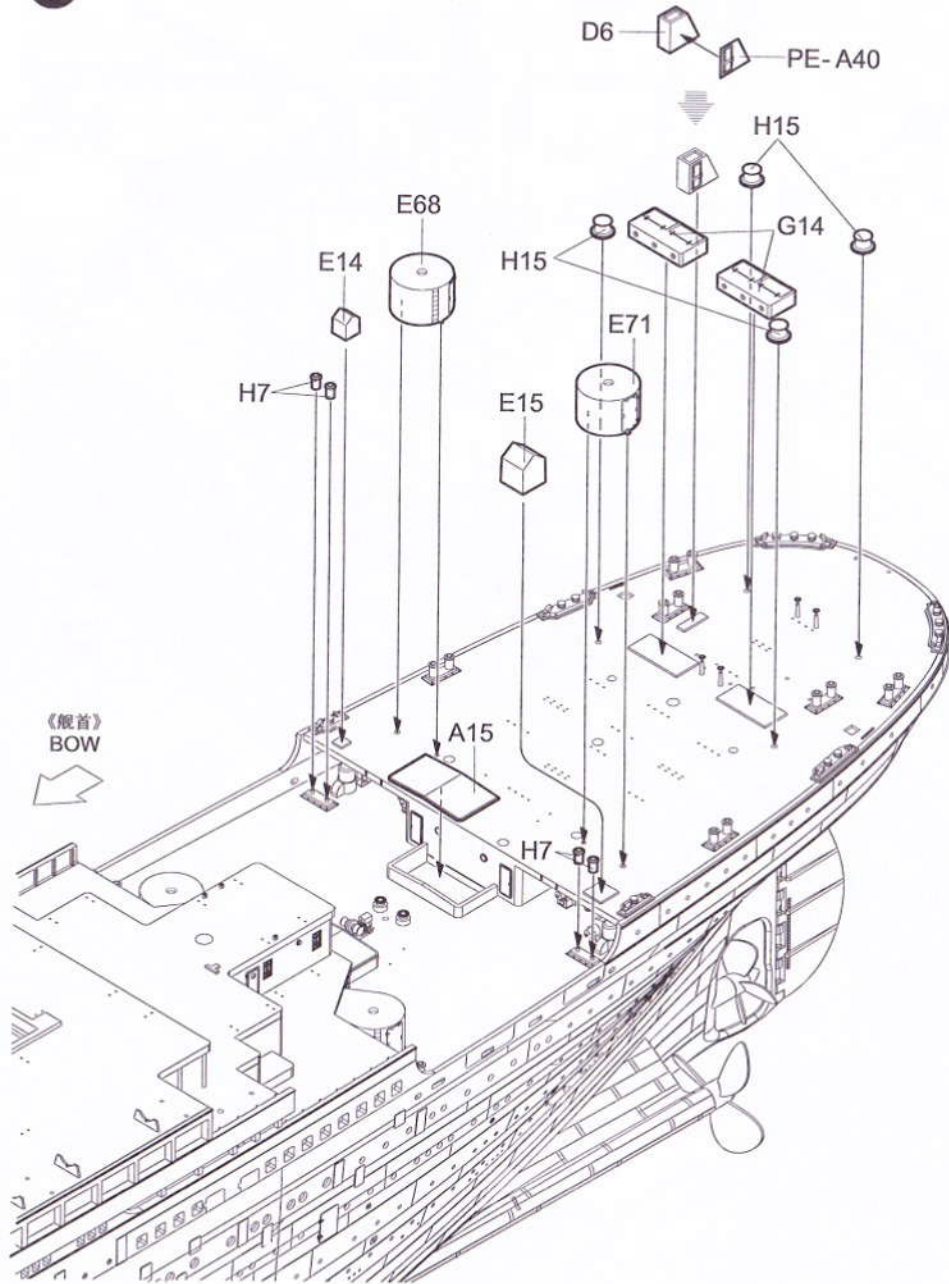

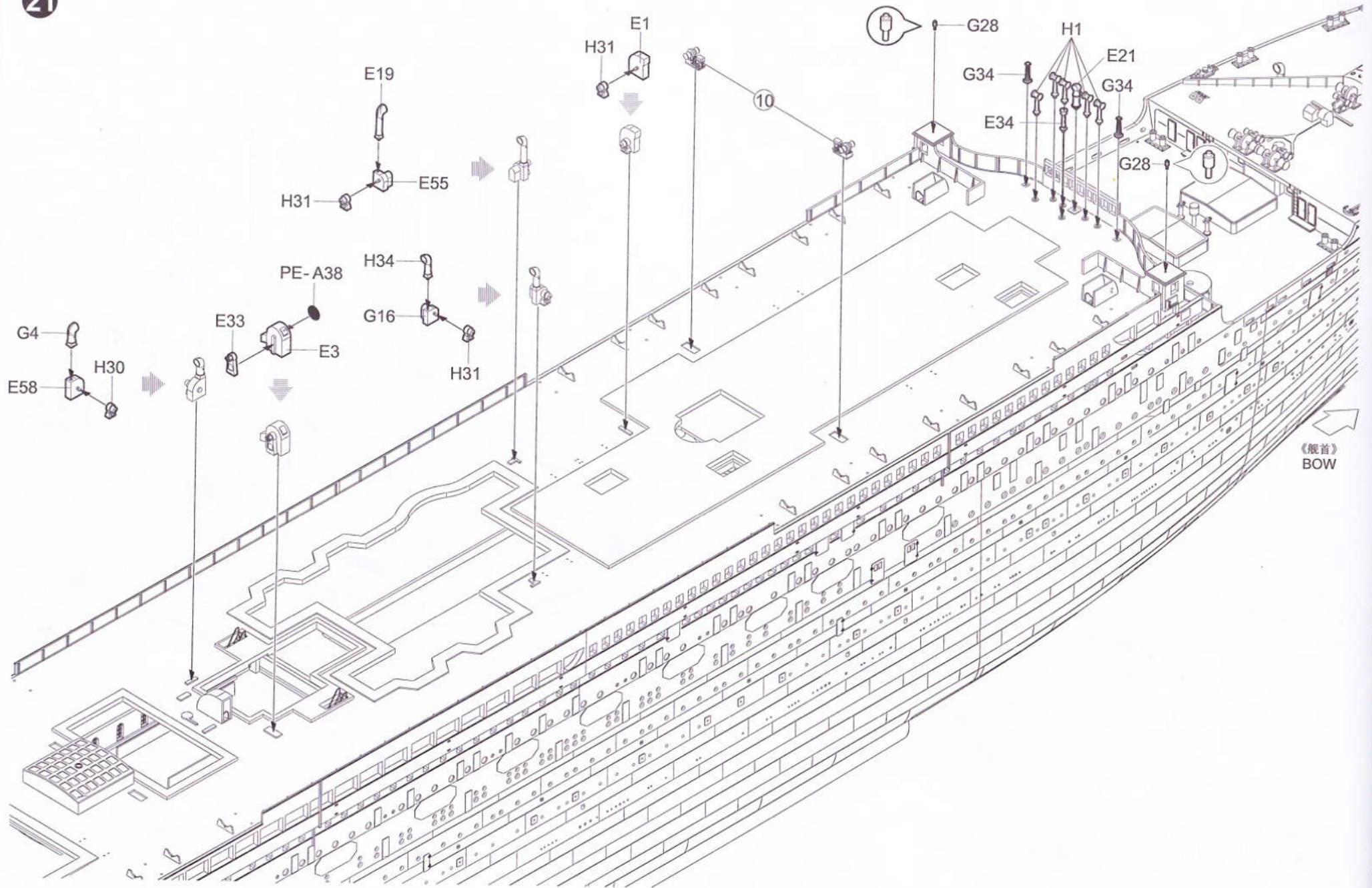

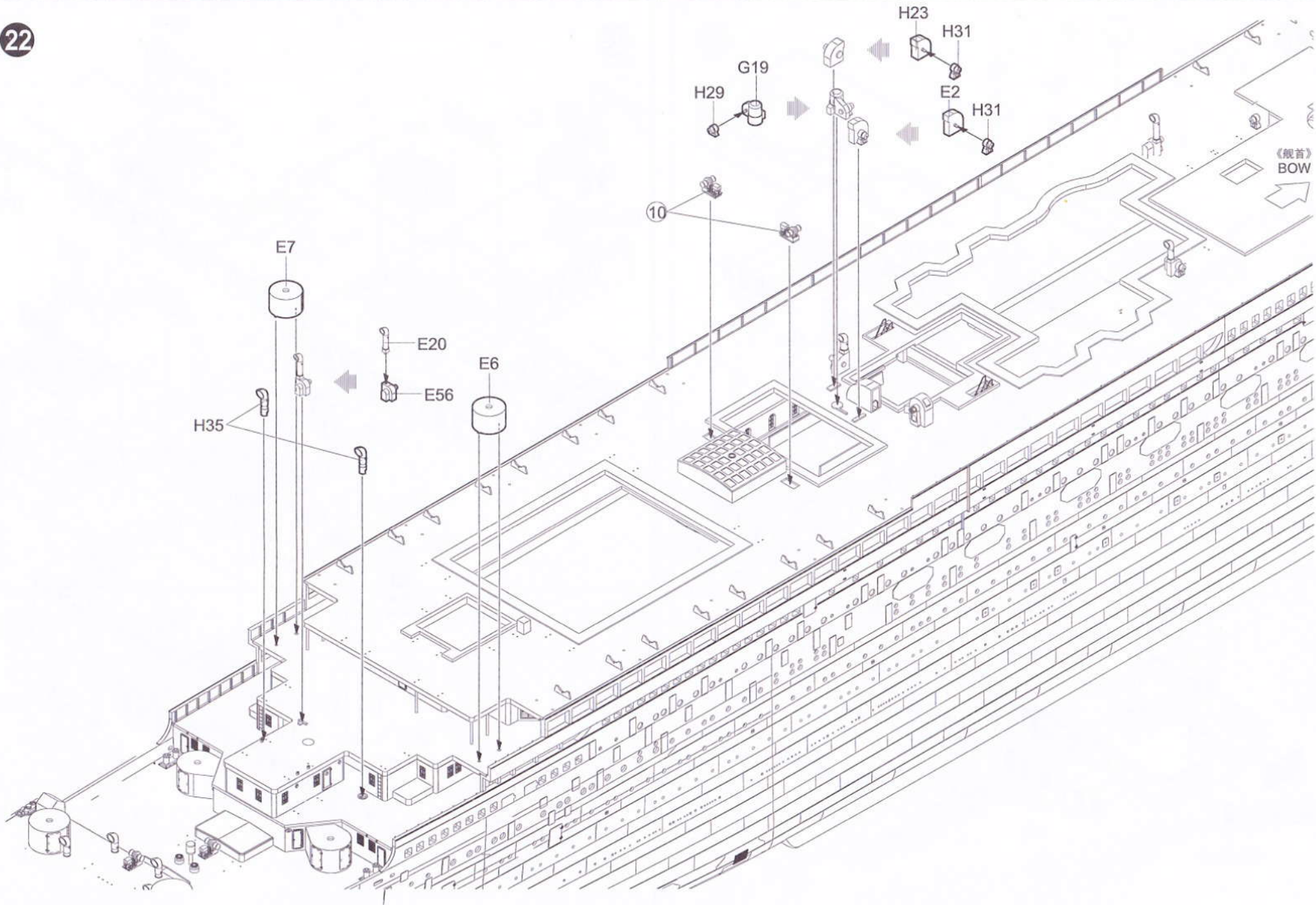

23

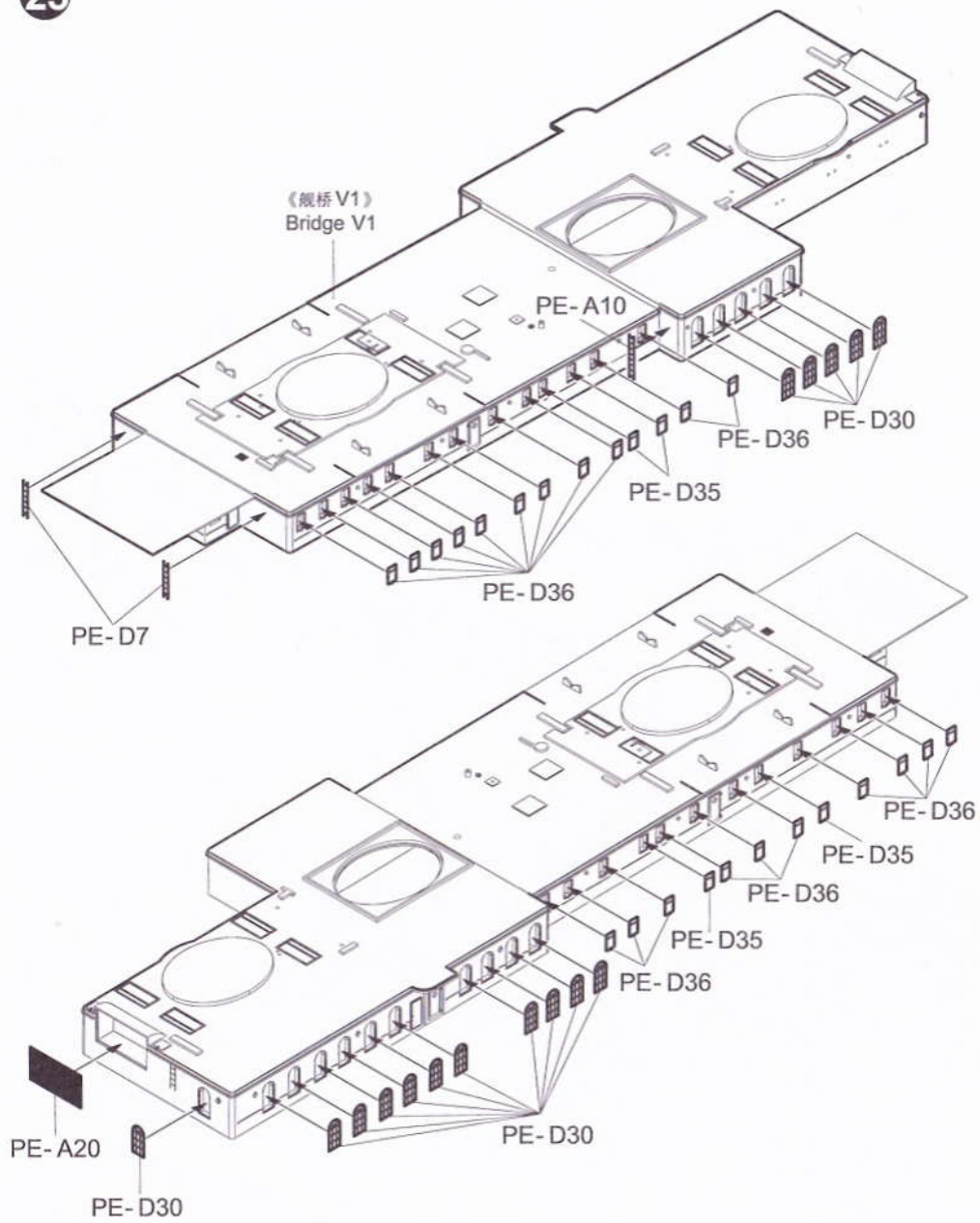

03719

24

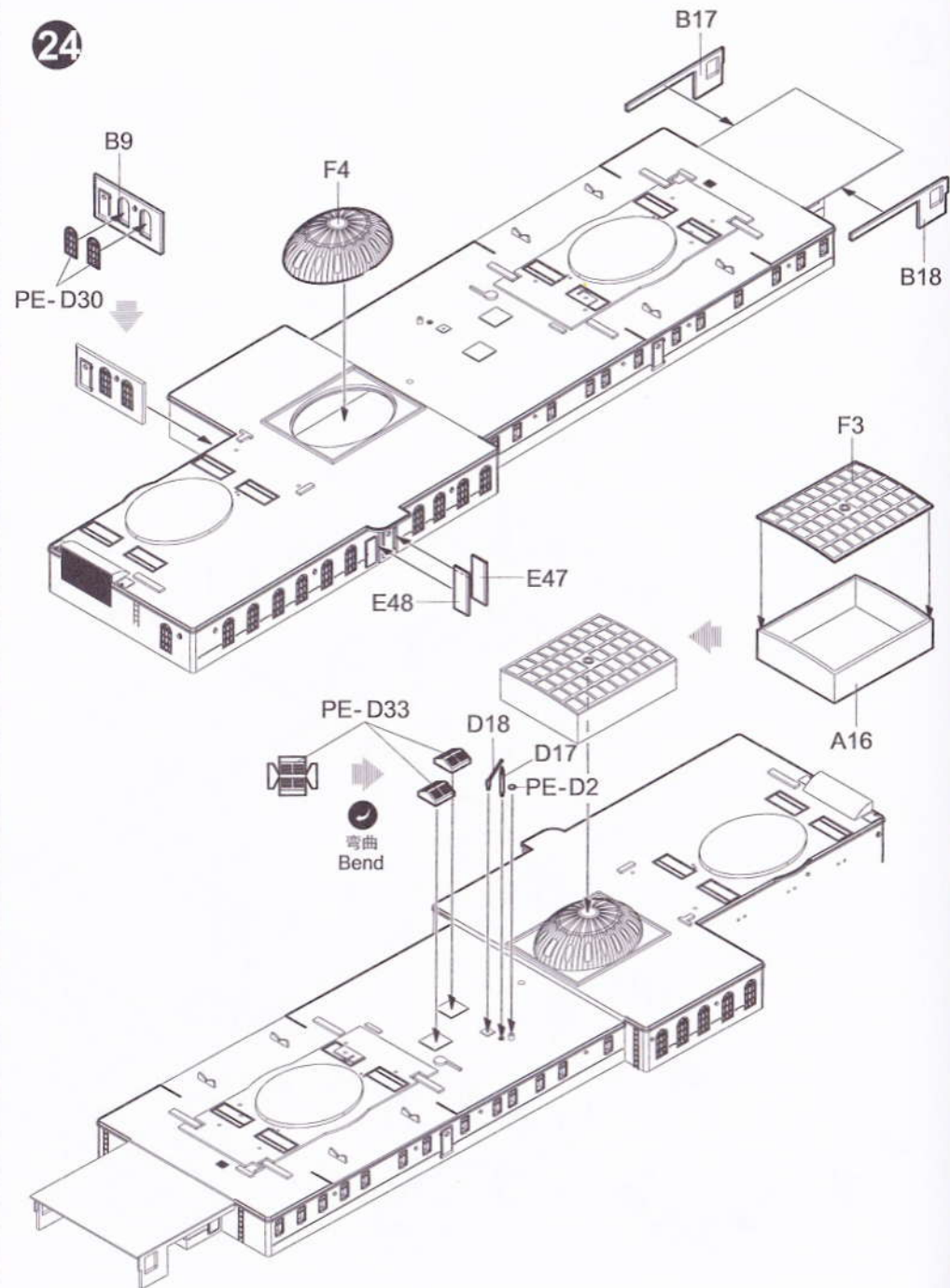

26

25

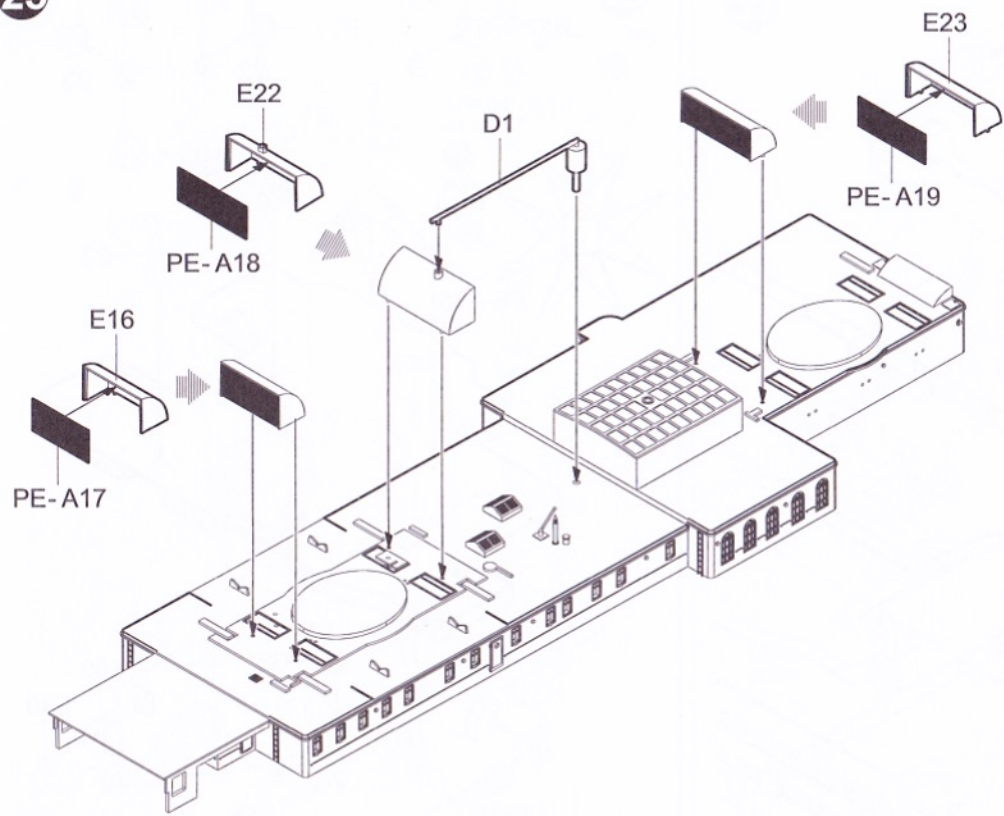

27

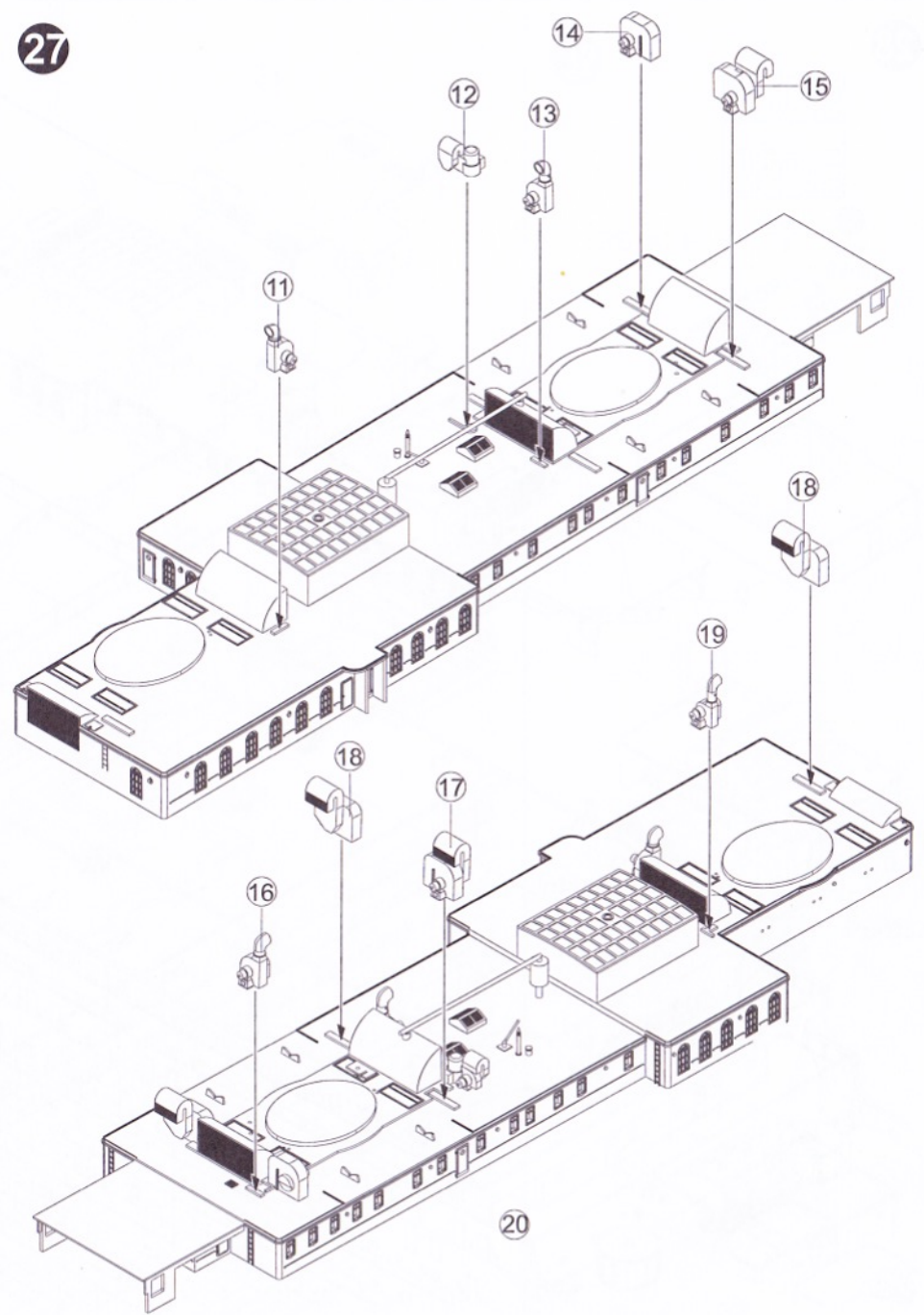

26

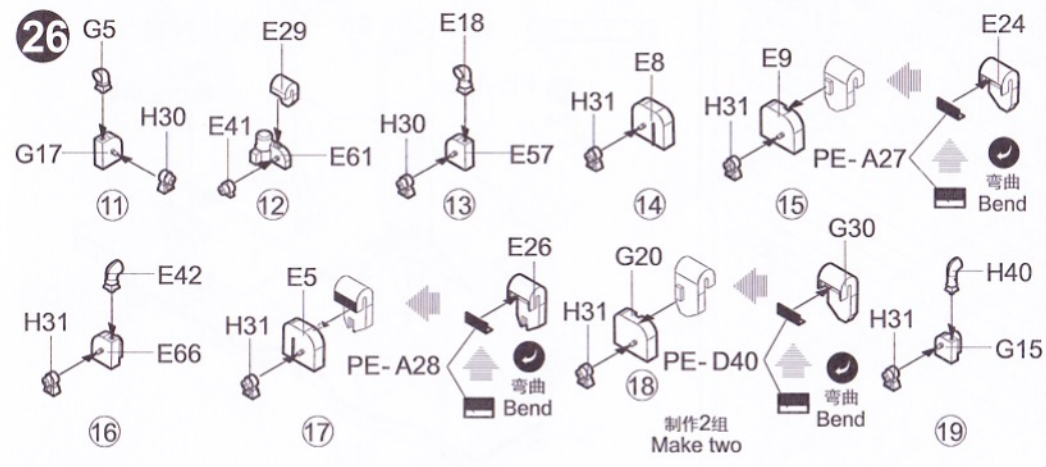

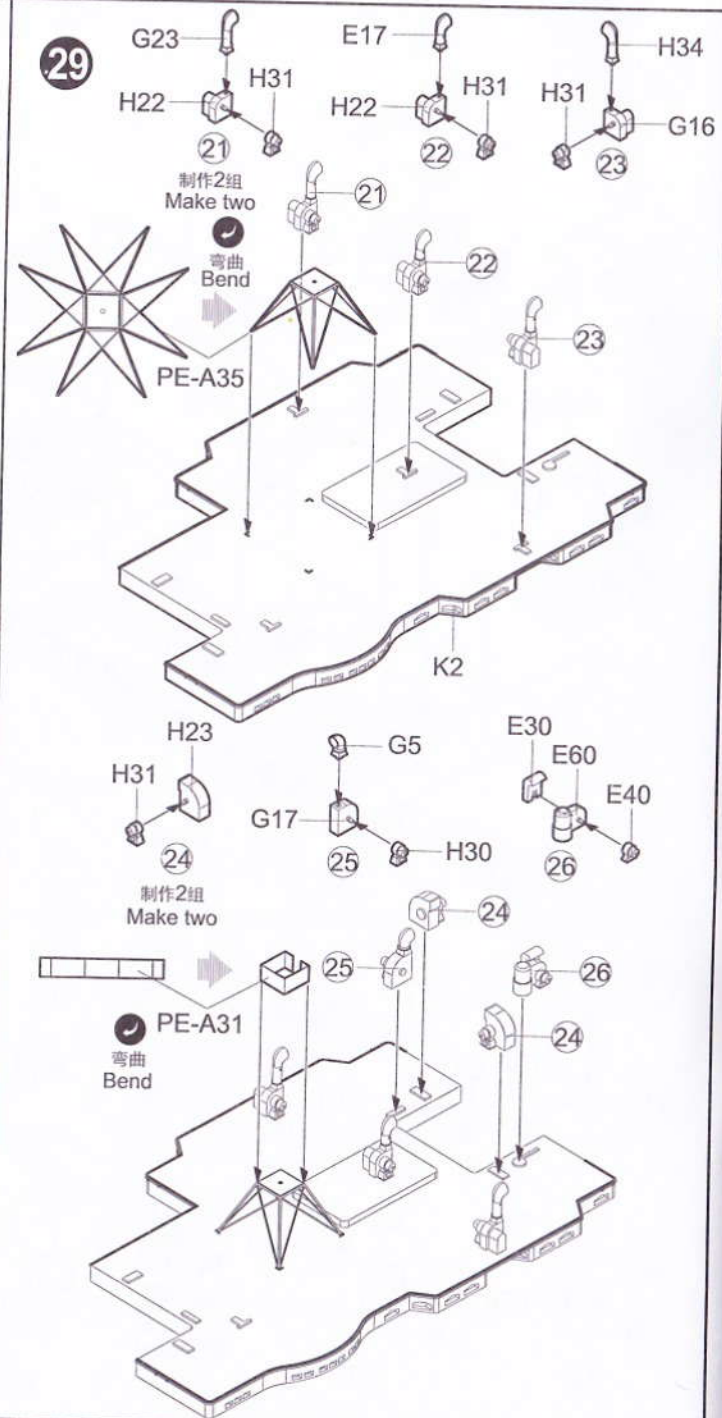
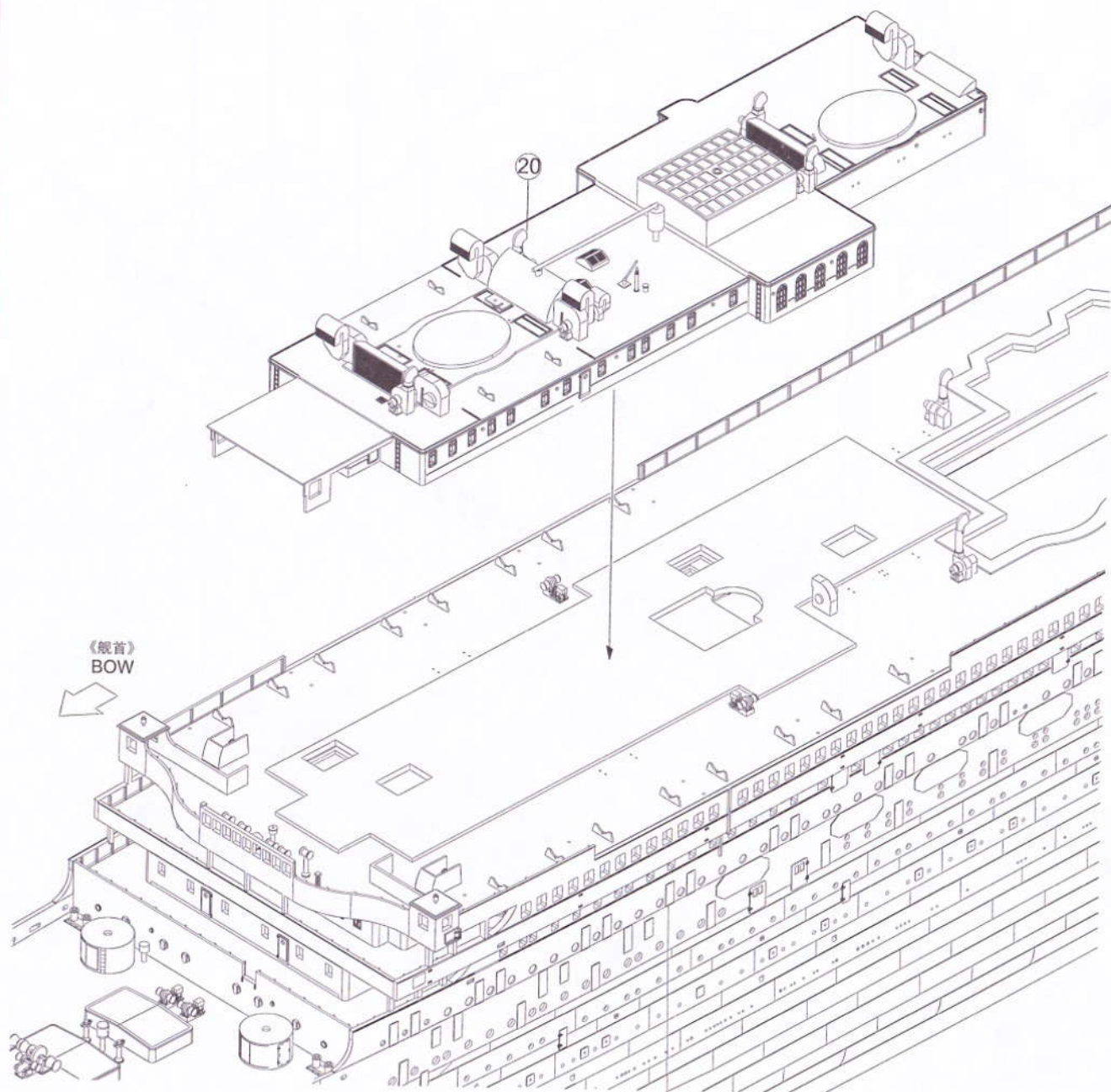

30

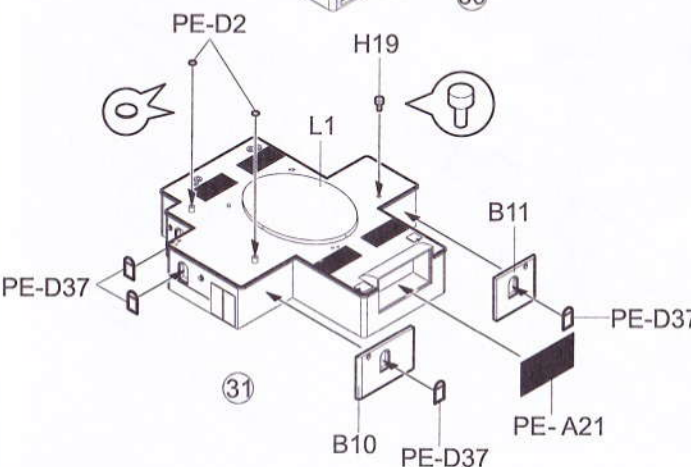
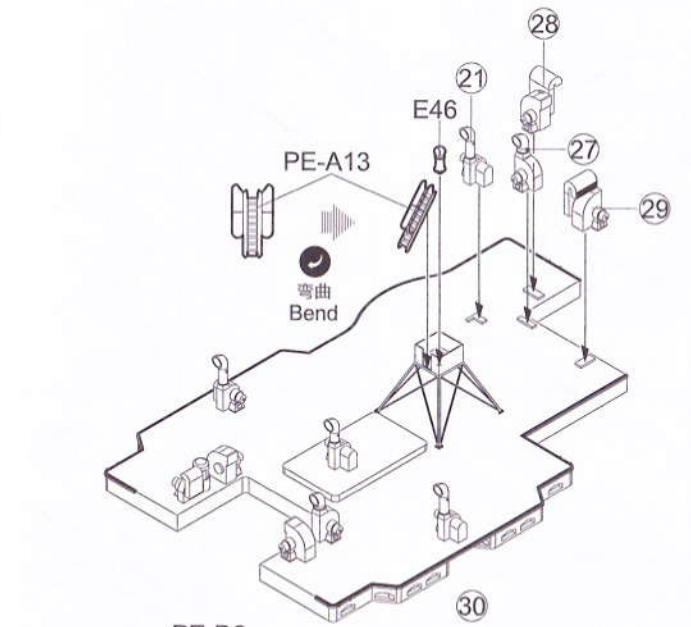
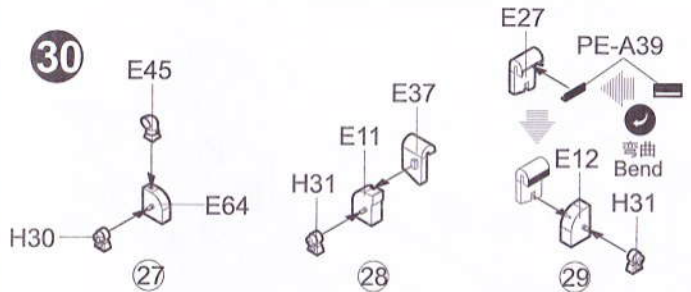

31

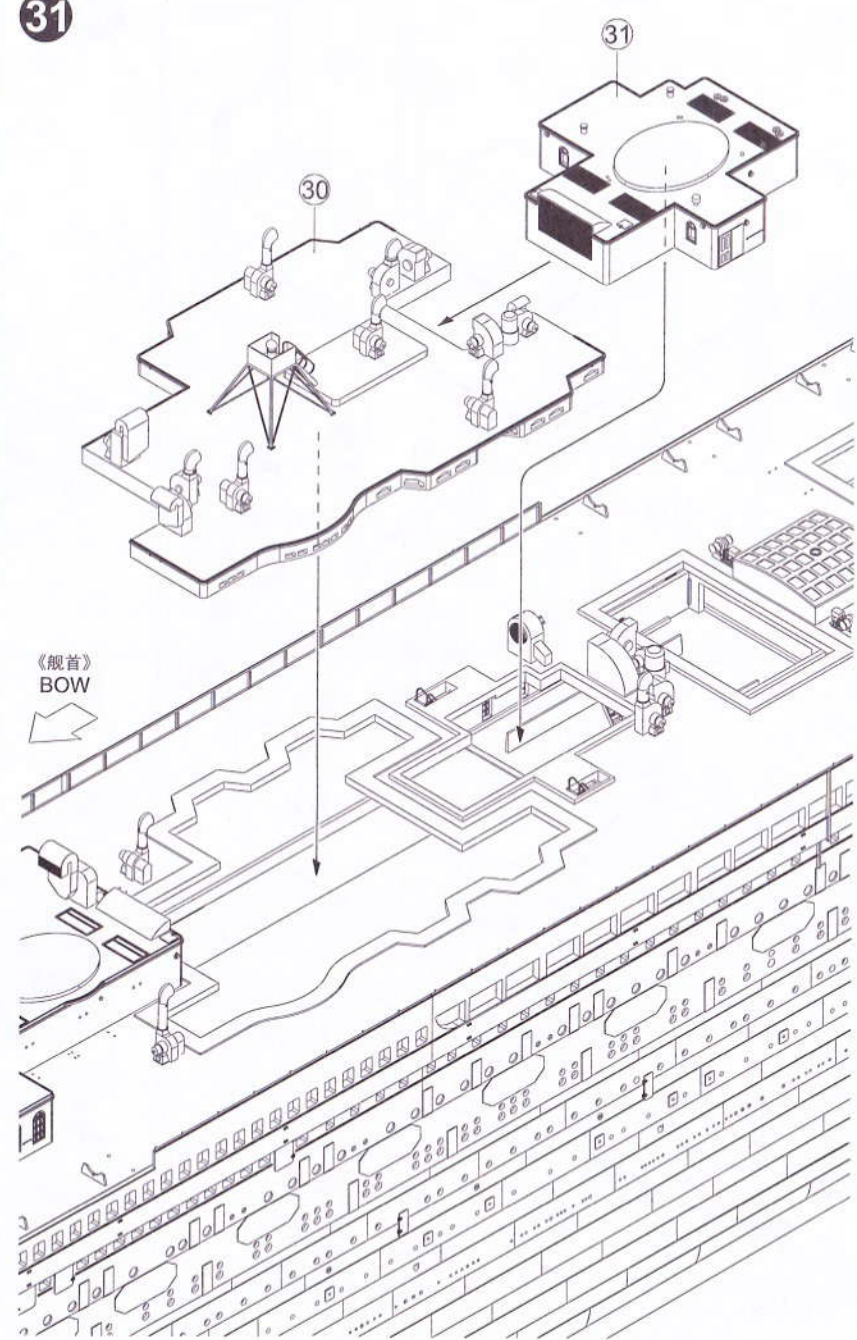

32

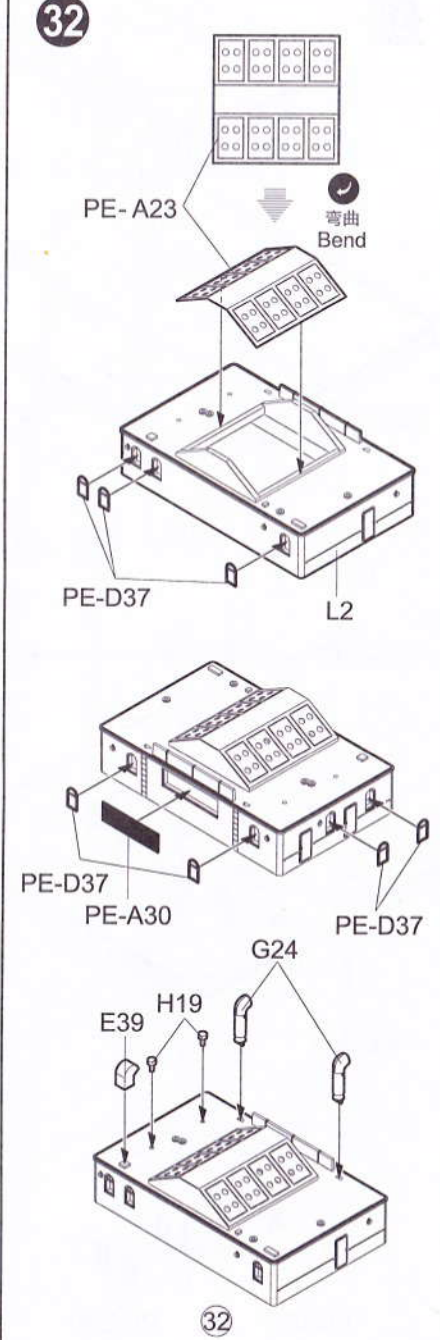

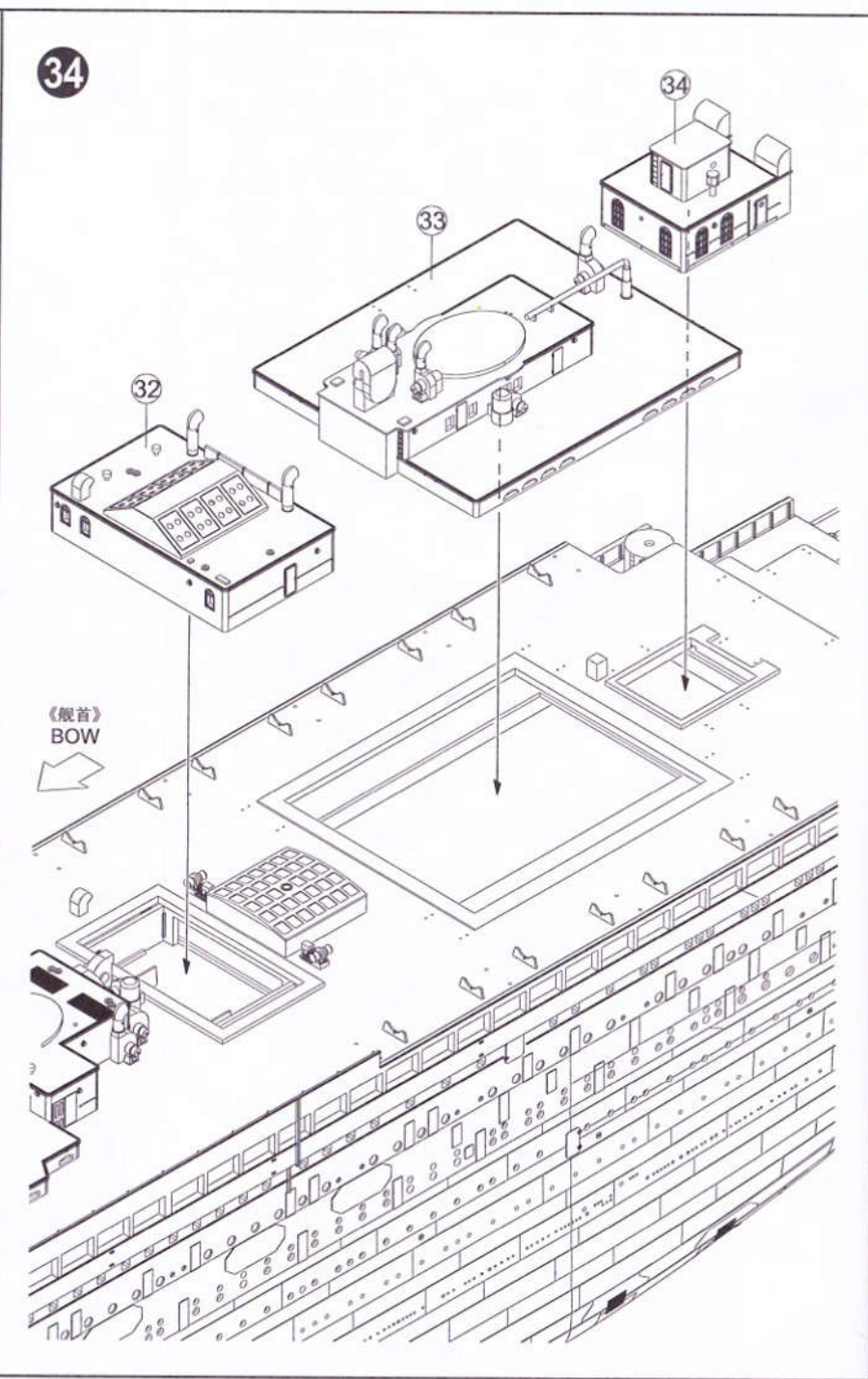
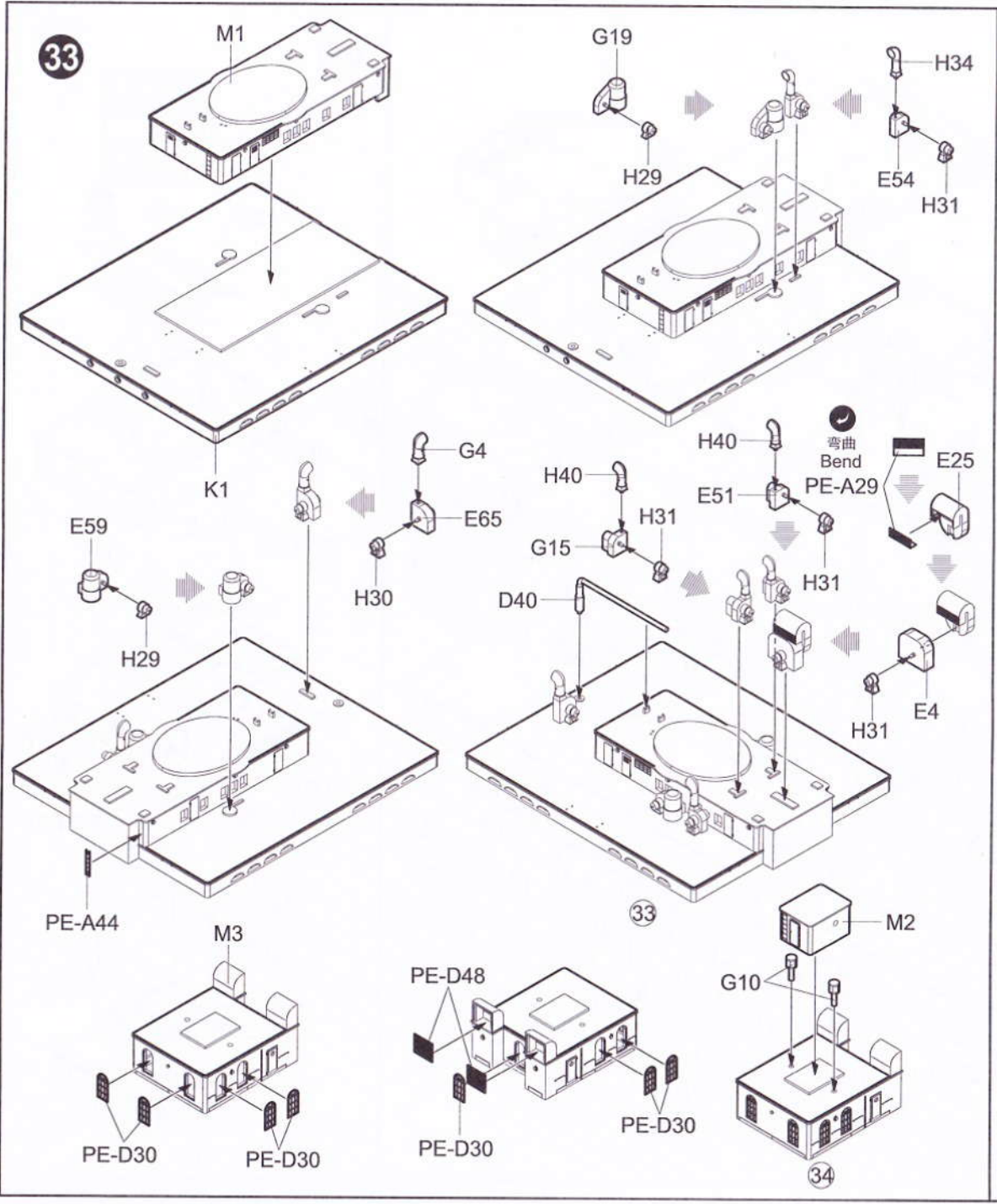

35

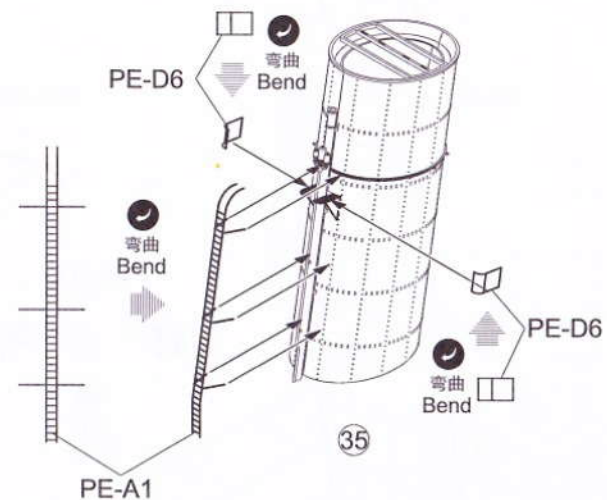
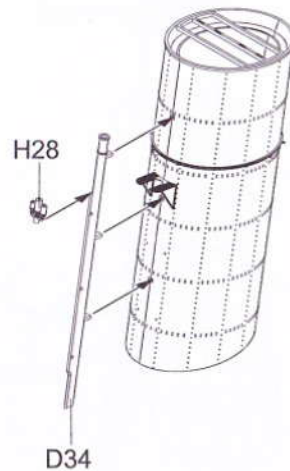
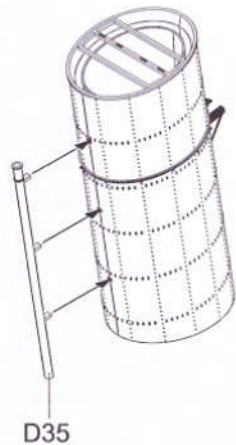
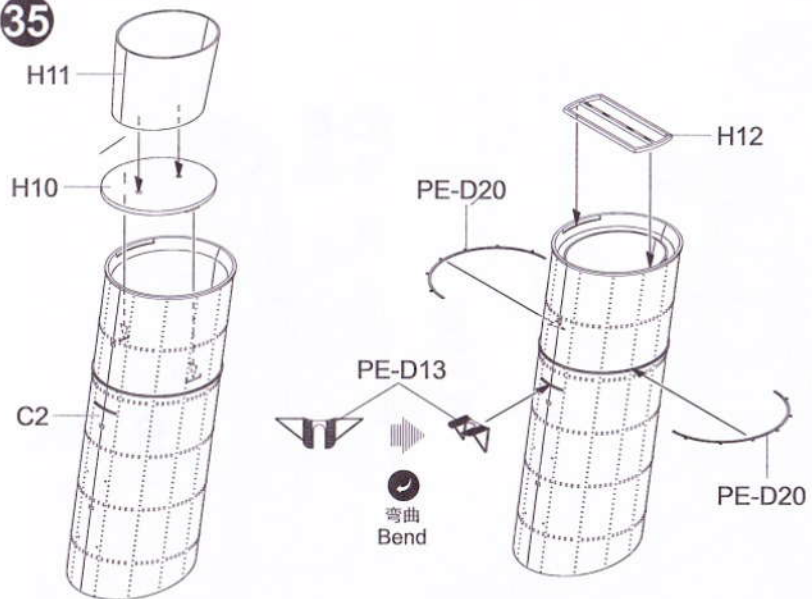

36

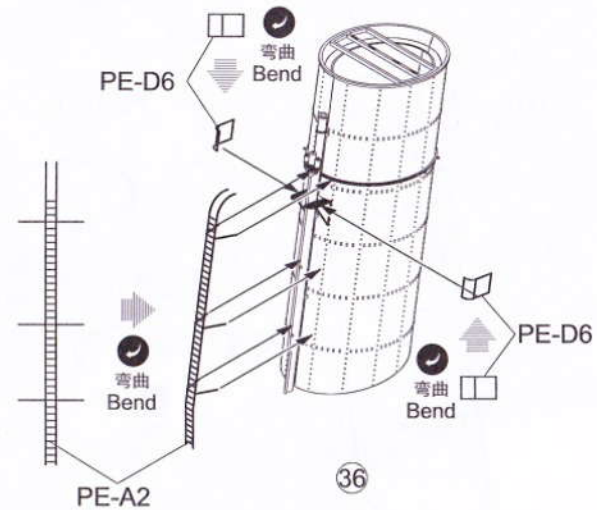
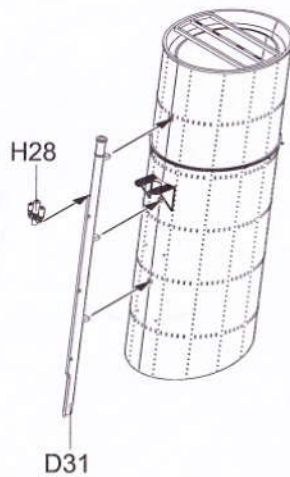
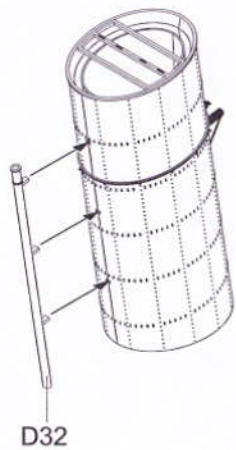
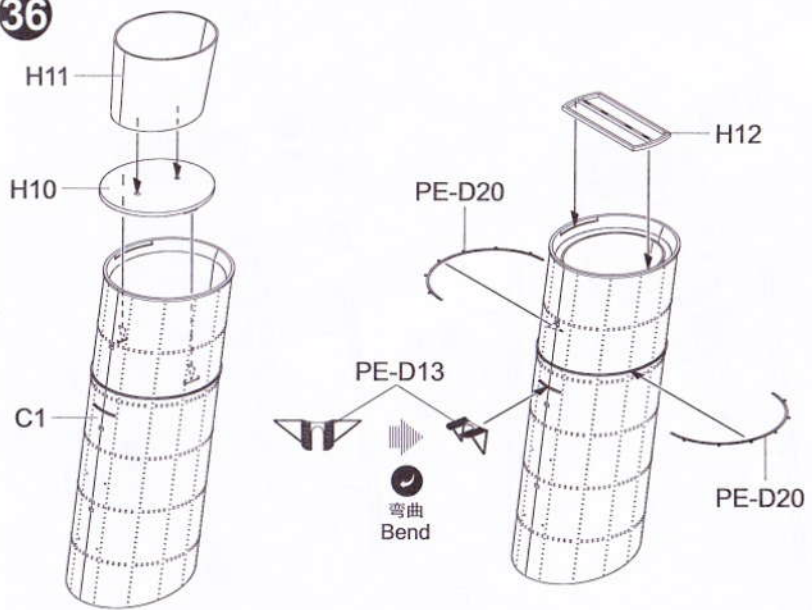

37

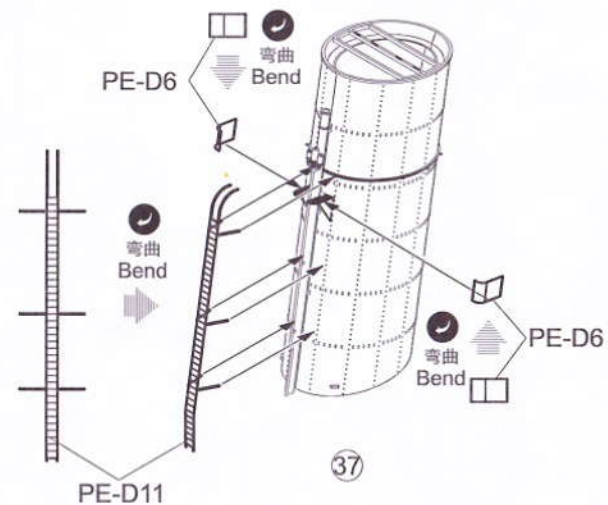
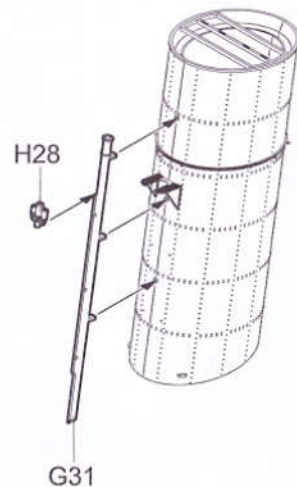
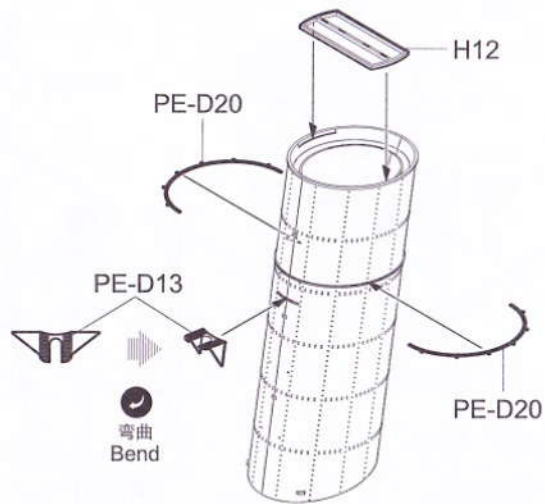
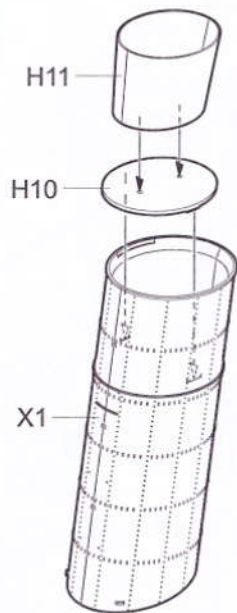

38

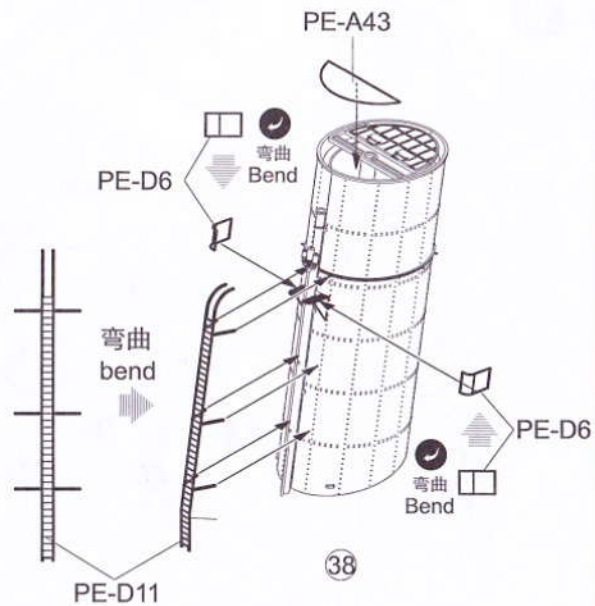
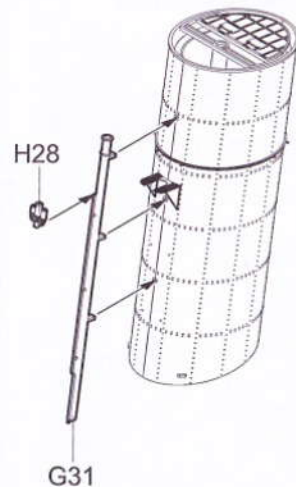
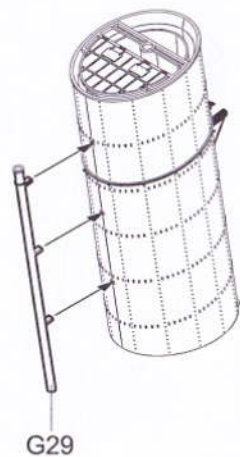
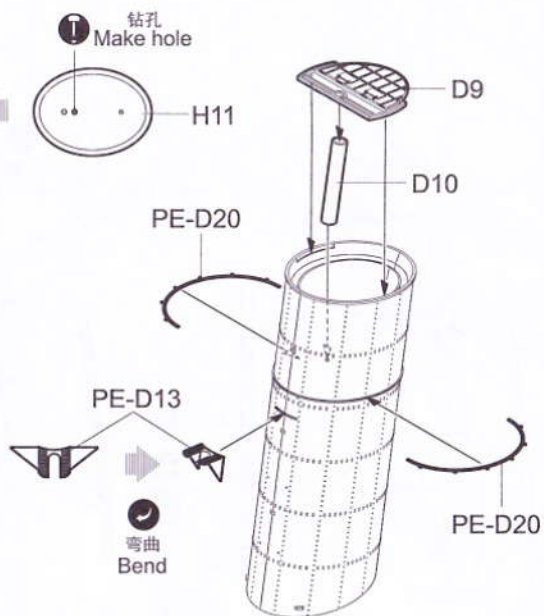
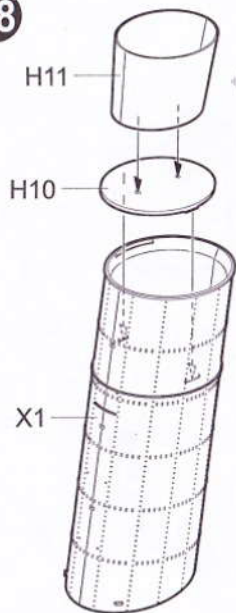

39

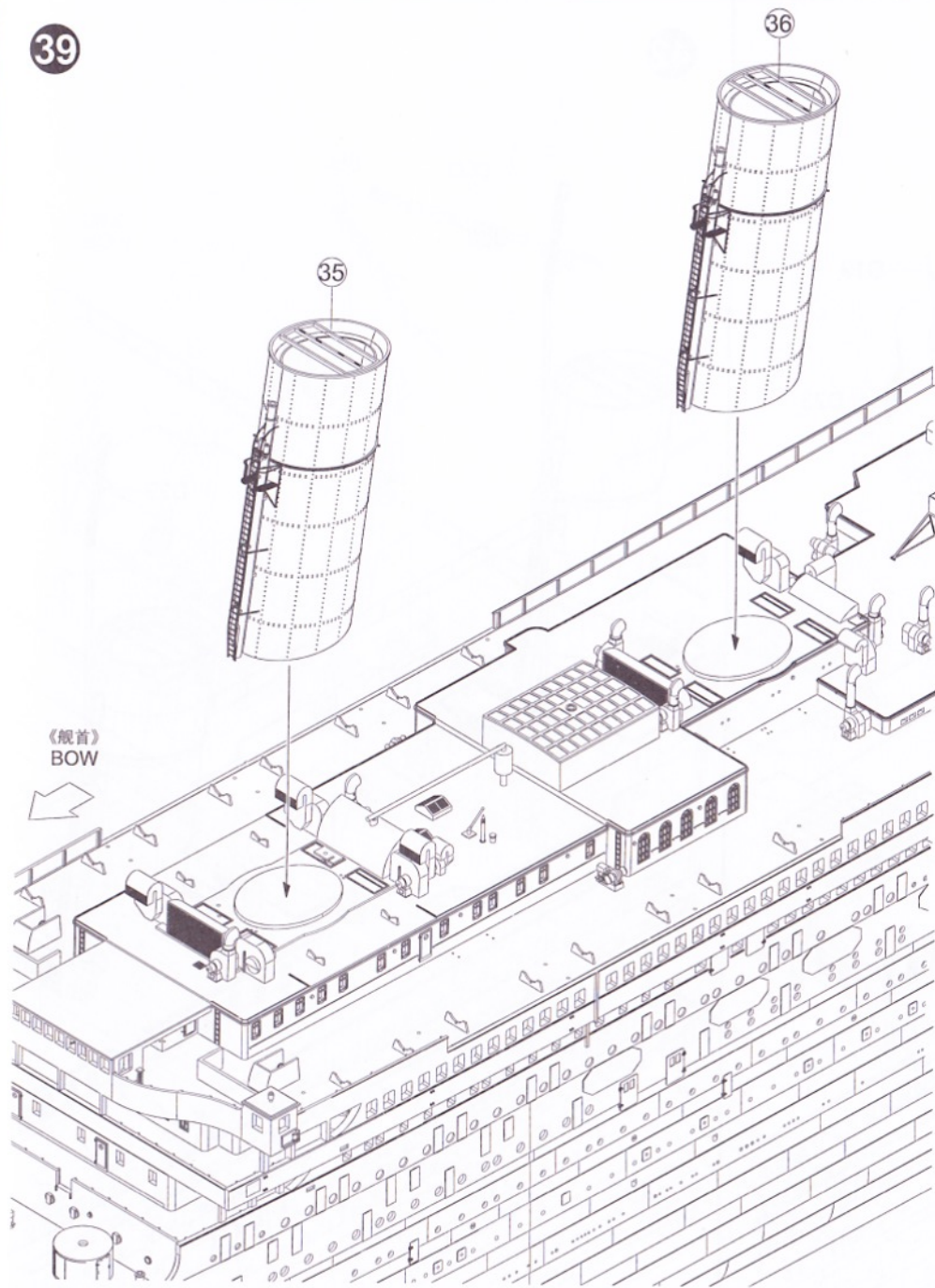

03719

33

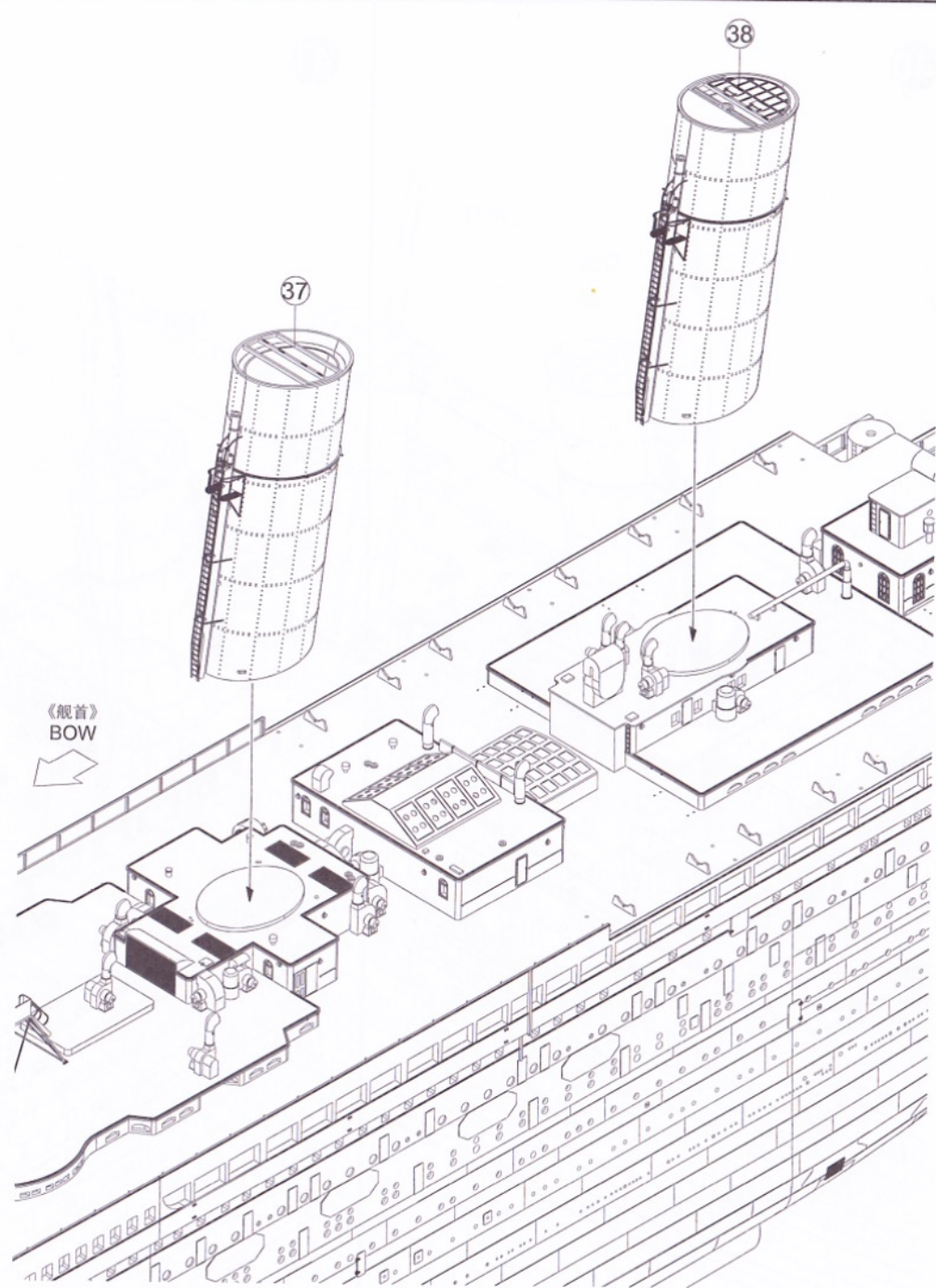

40

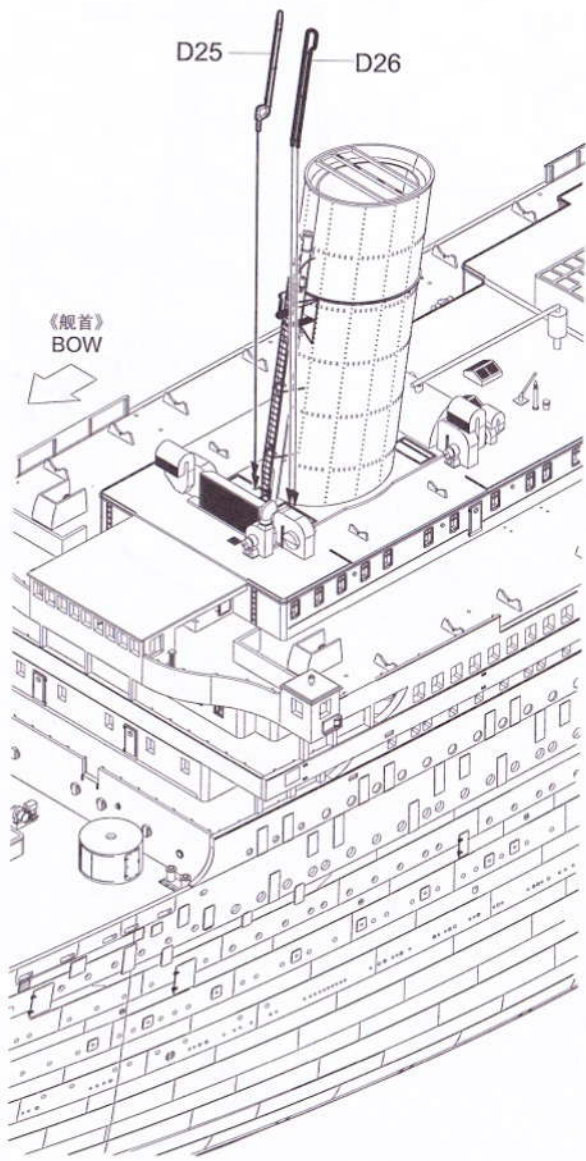

41

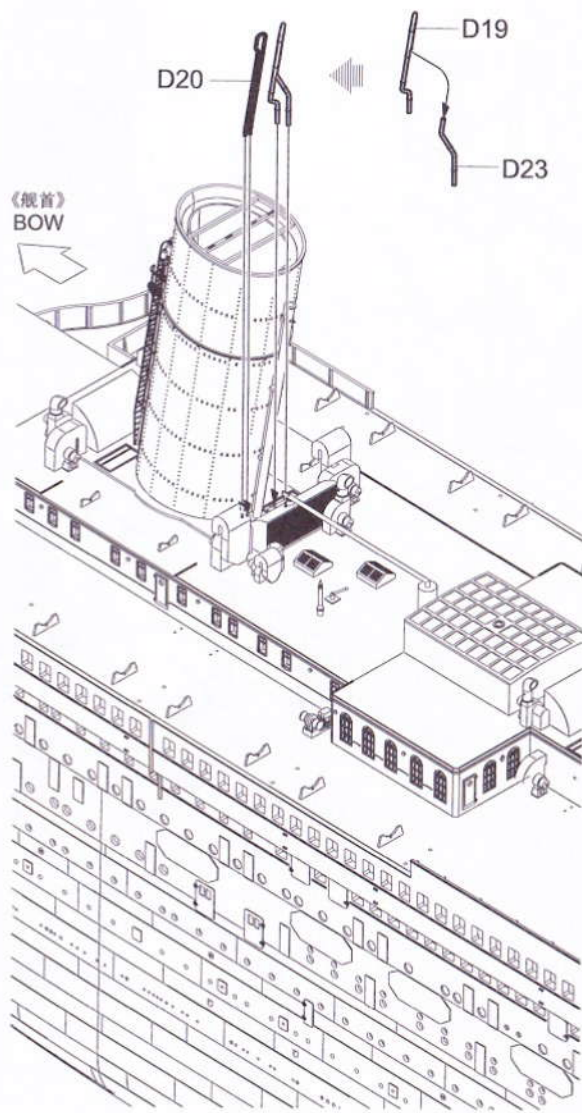

42

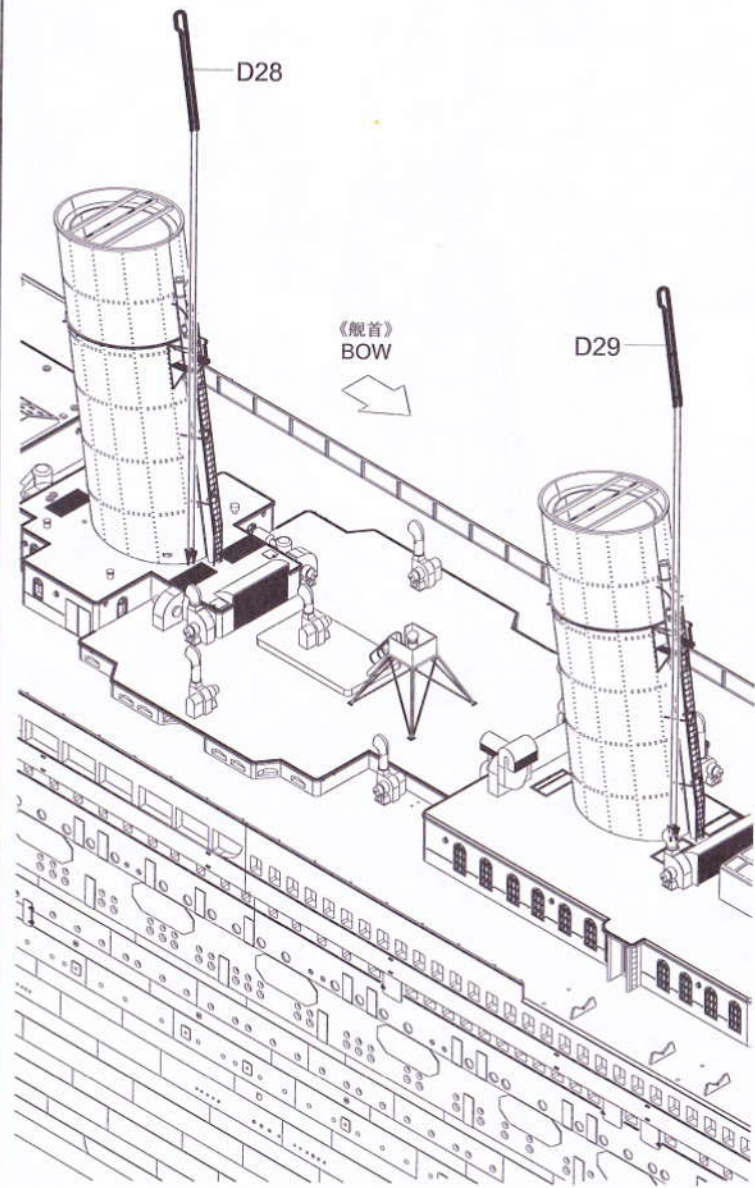

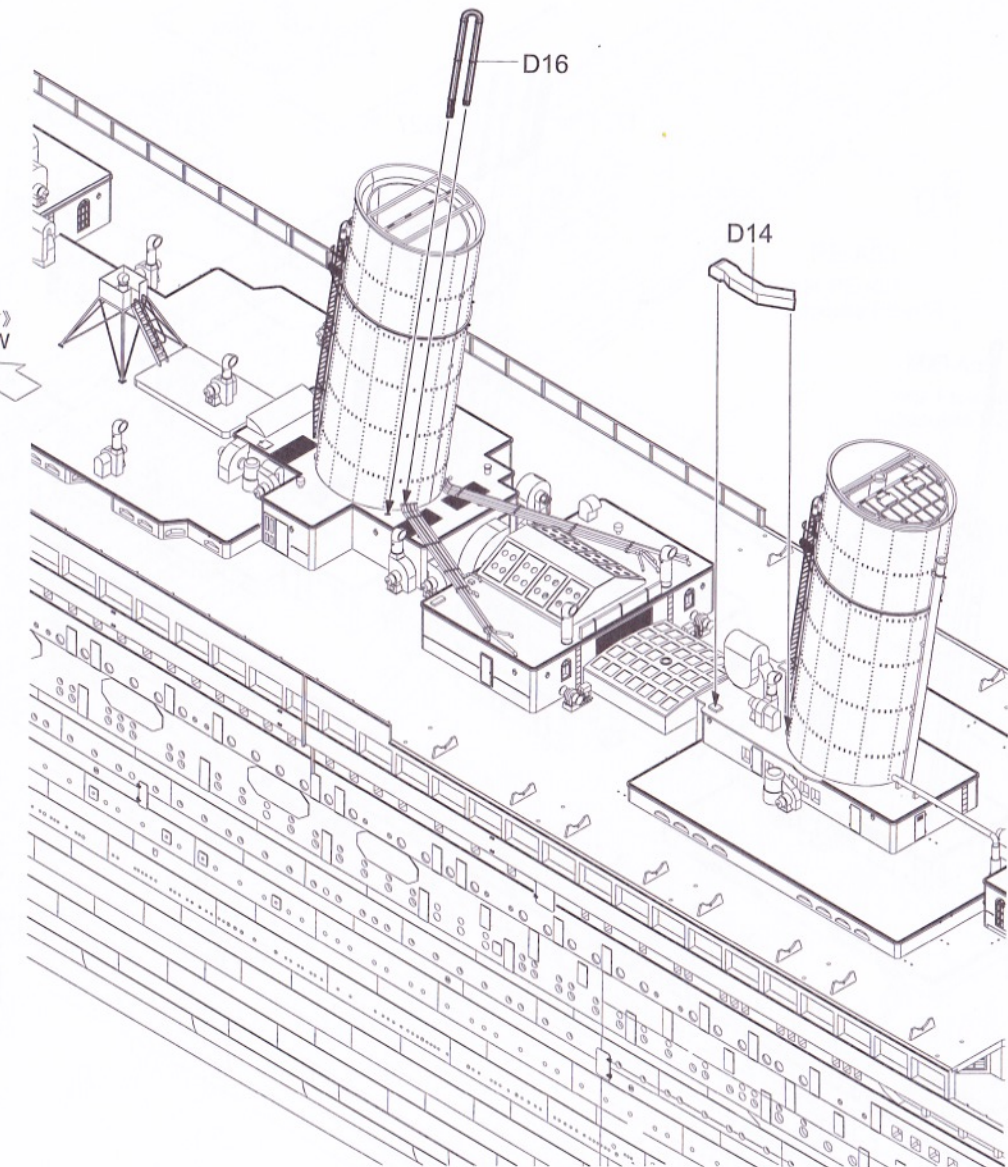
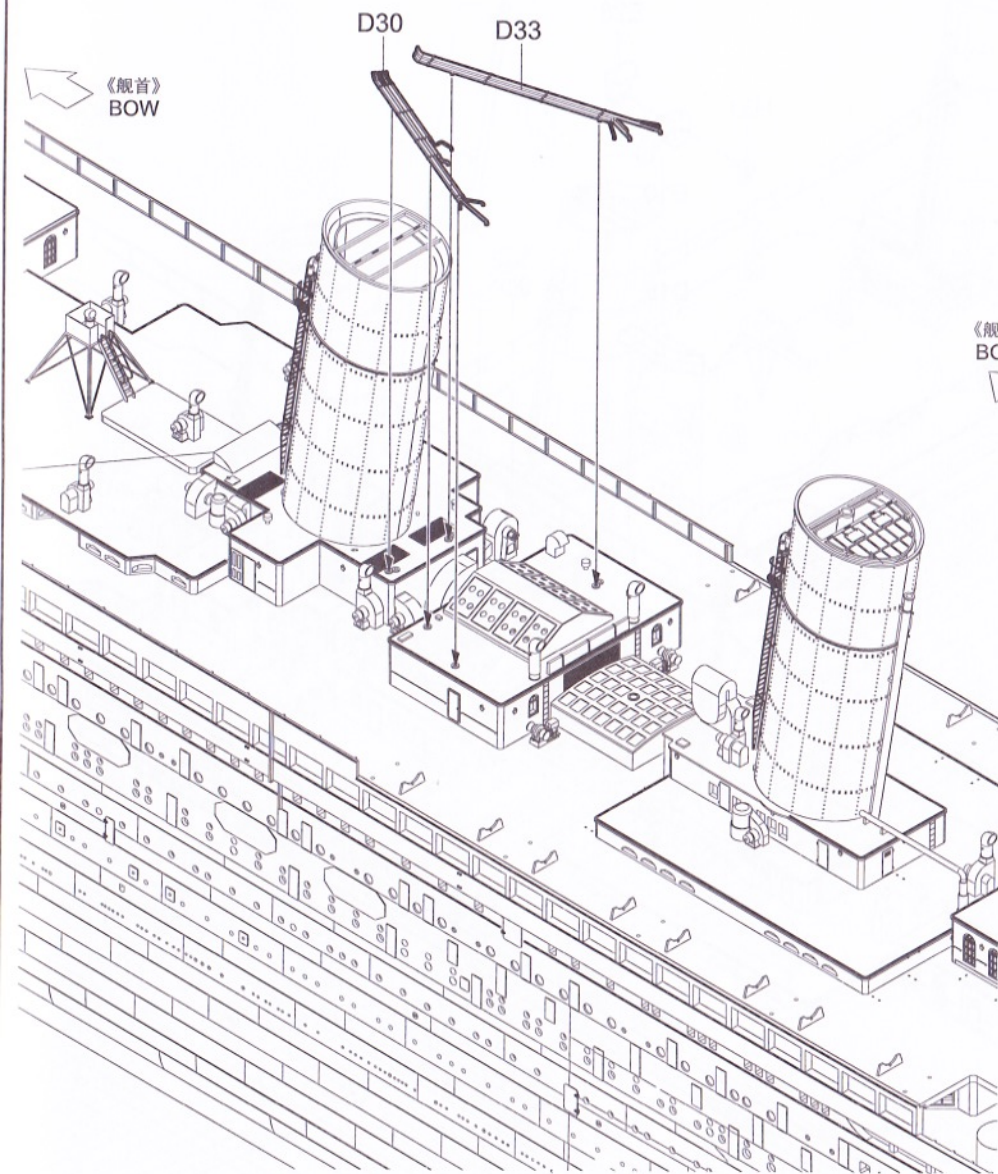

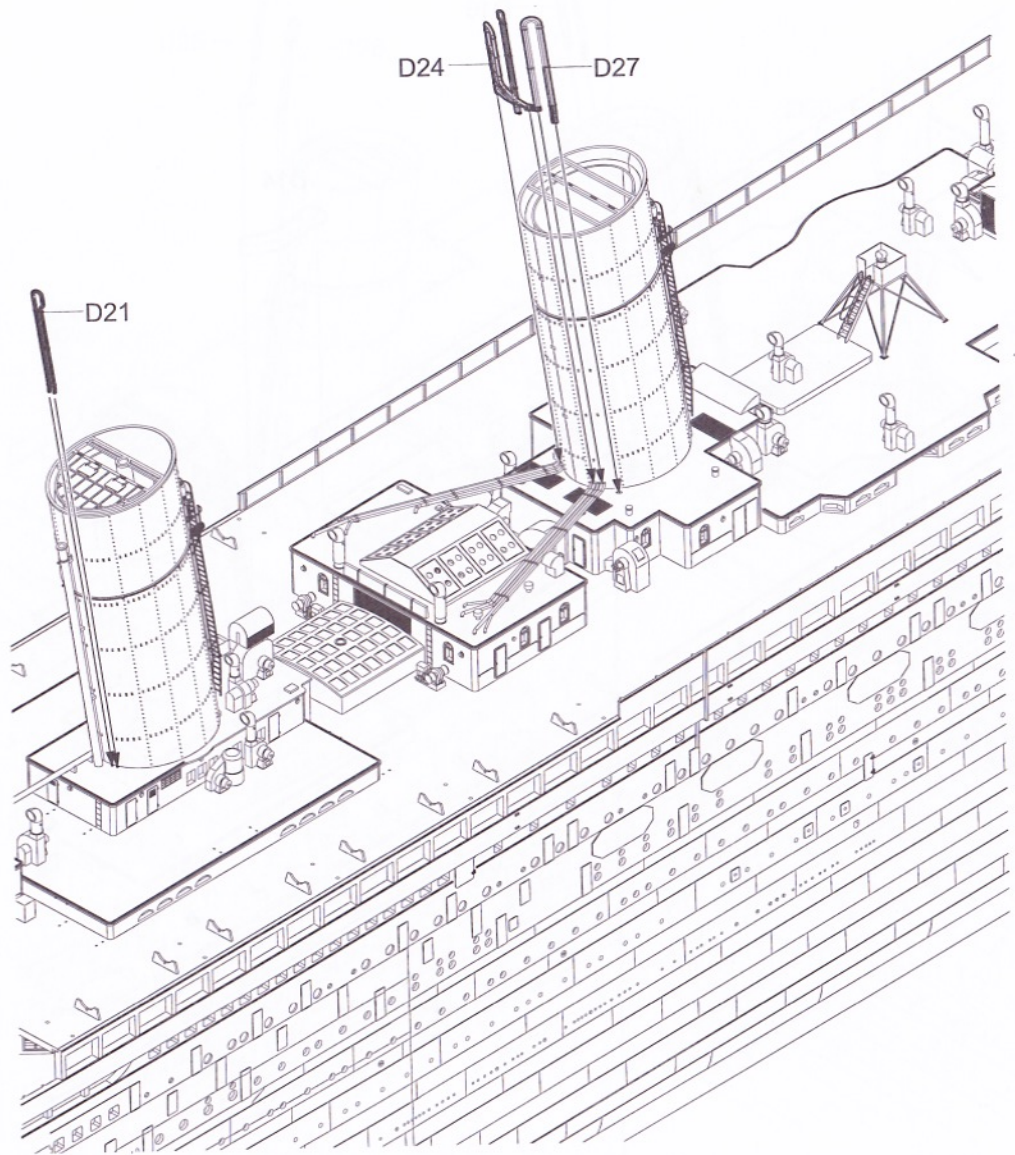

《舰首》
BOW

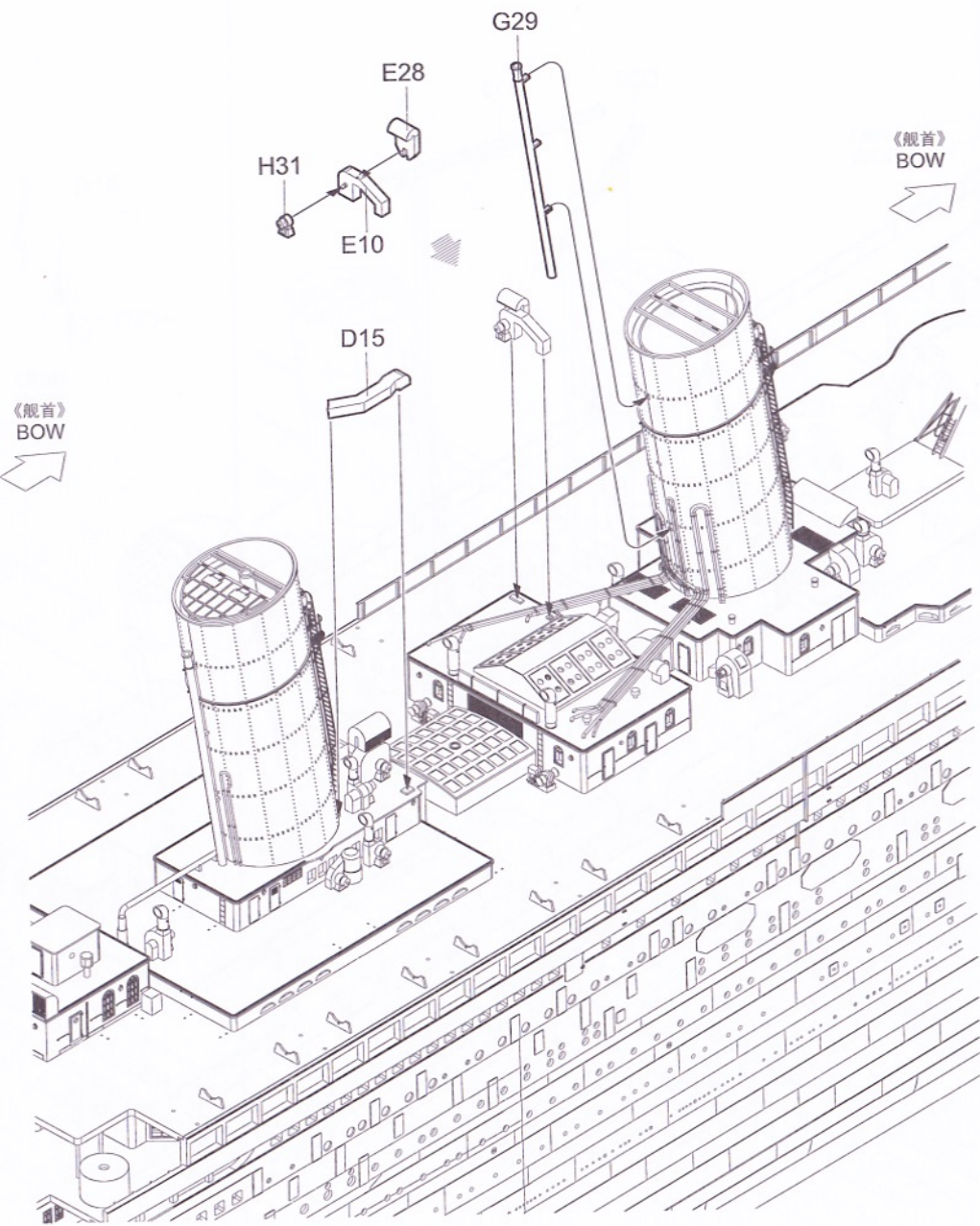

《舰首》
BOW

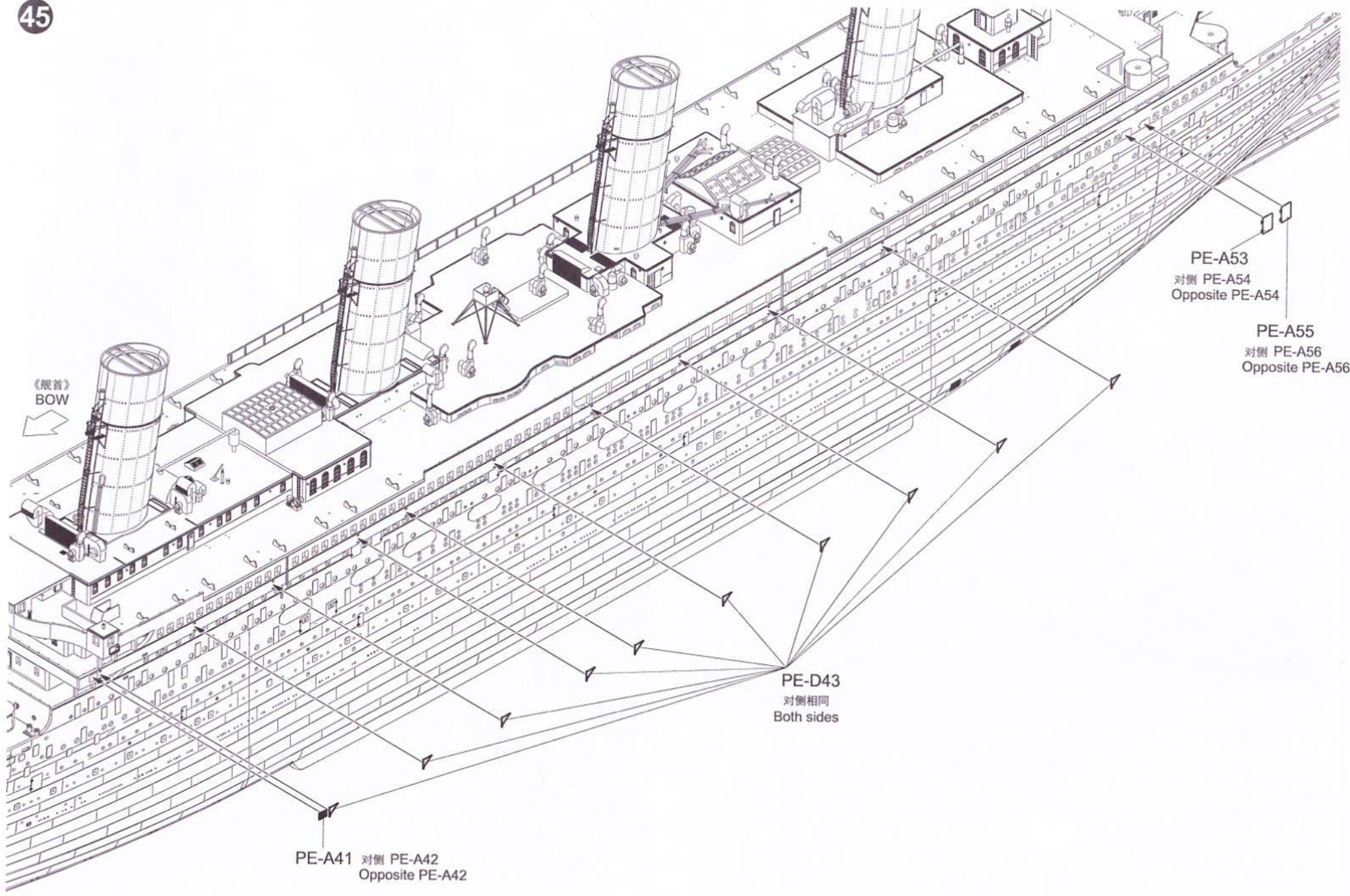

《舰首》
BOW

PE-A53
对侧 PE-A54
Opposite PE-A54

PE-A55
对侧 PE-A56
Opposite PE-A56

PE-D43
对侧相同
Both sides

PE-A41 对侧 PE-A42
Opposite PE-A42

46

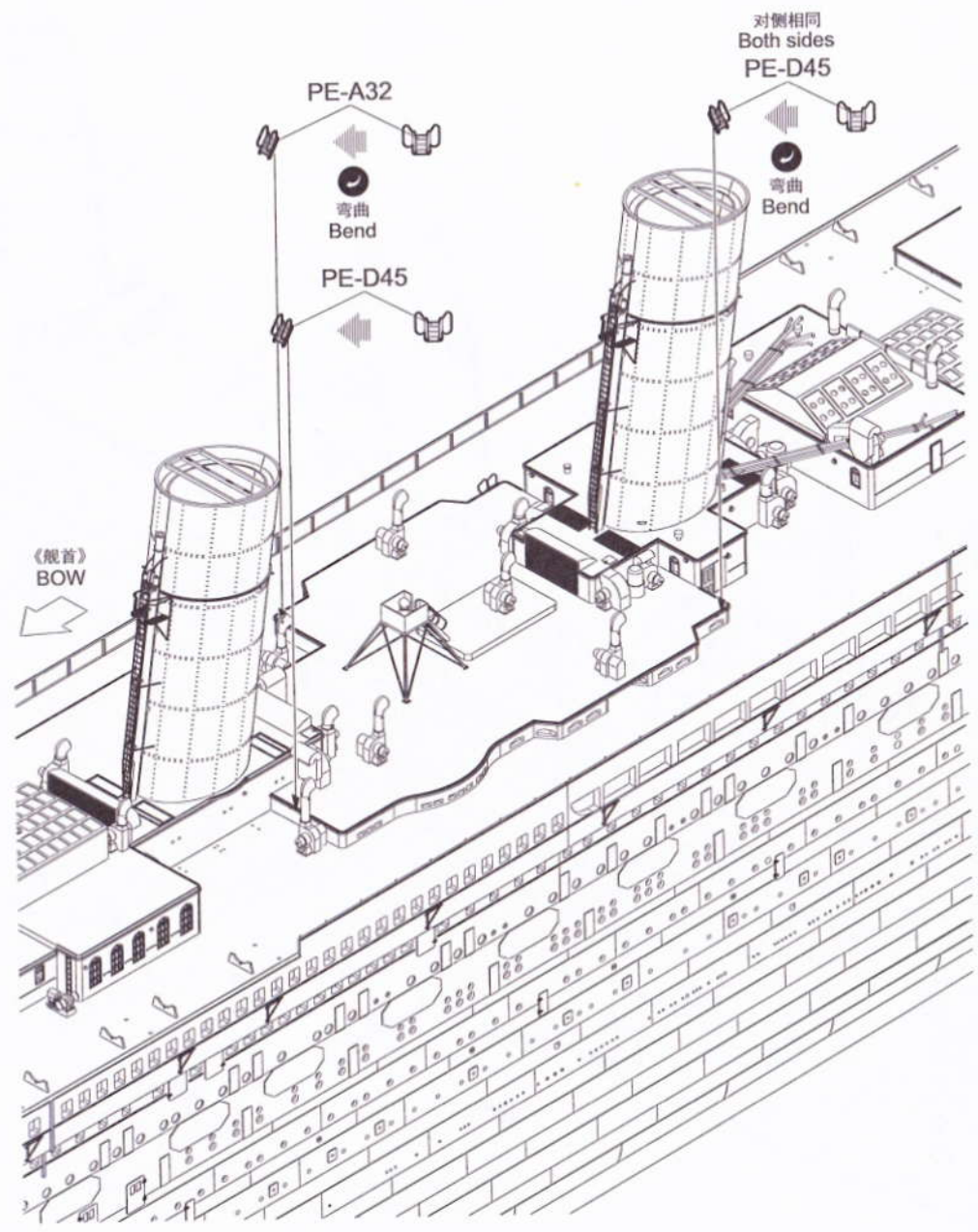
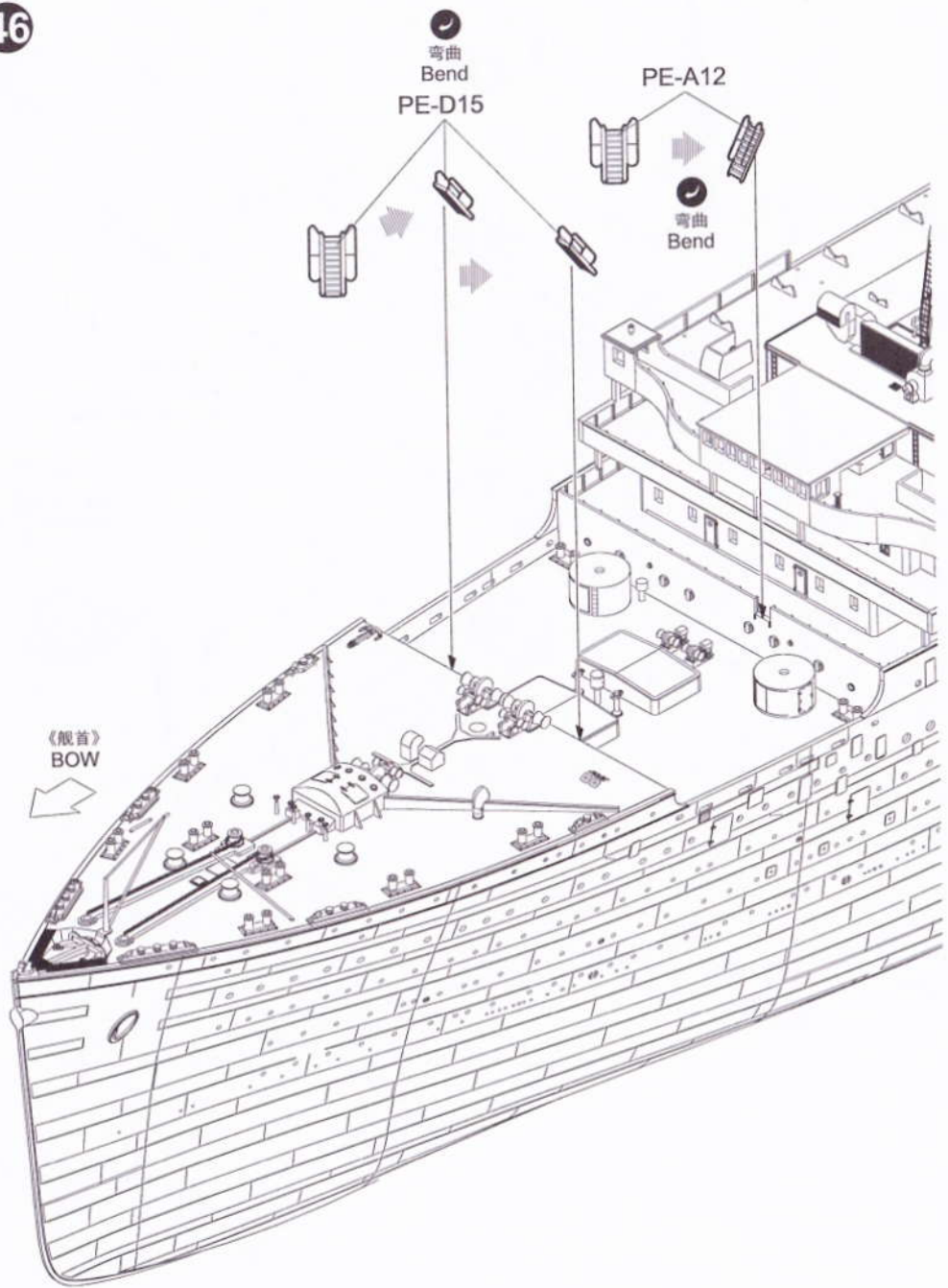

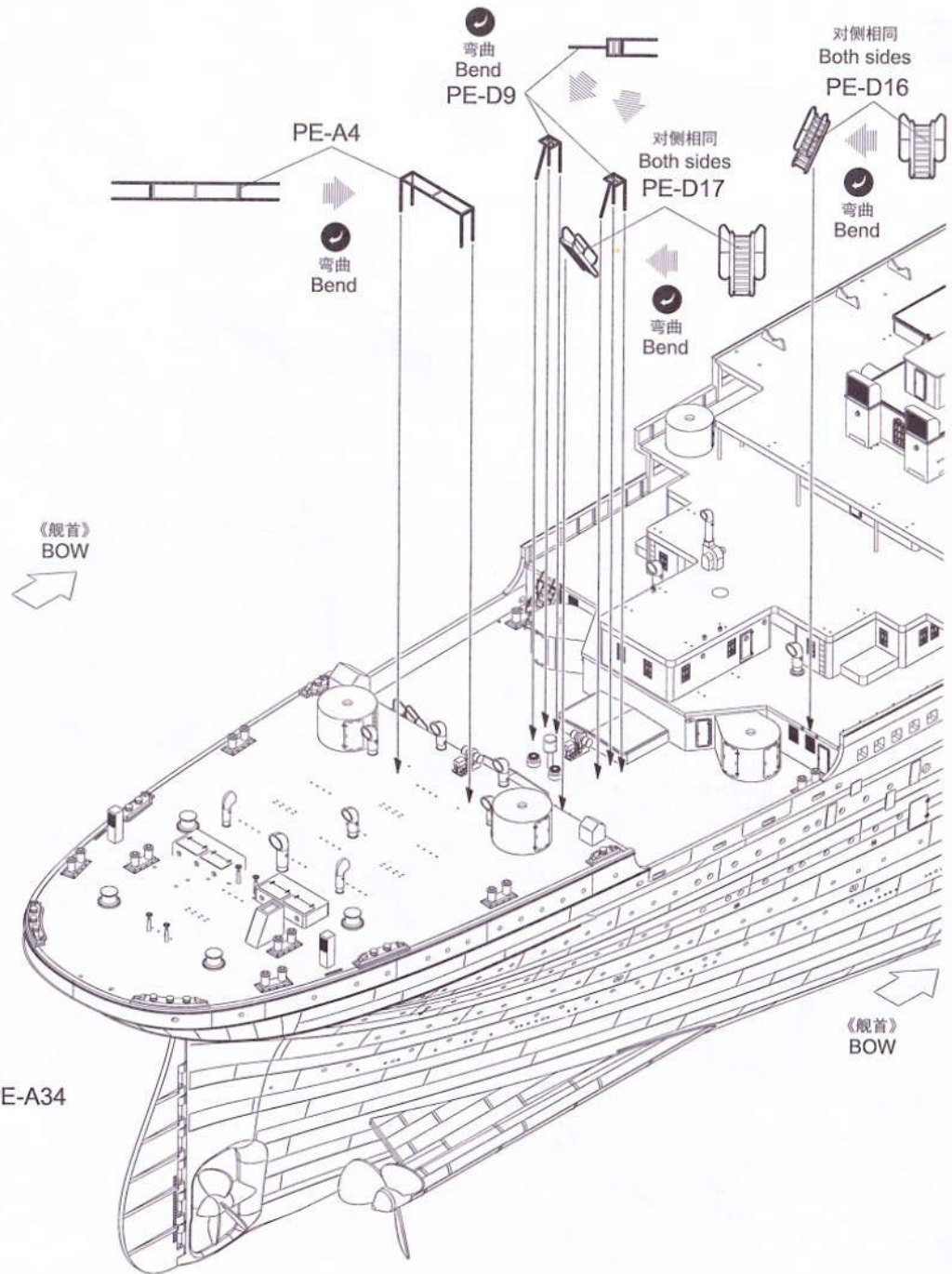
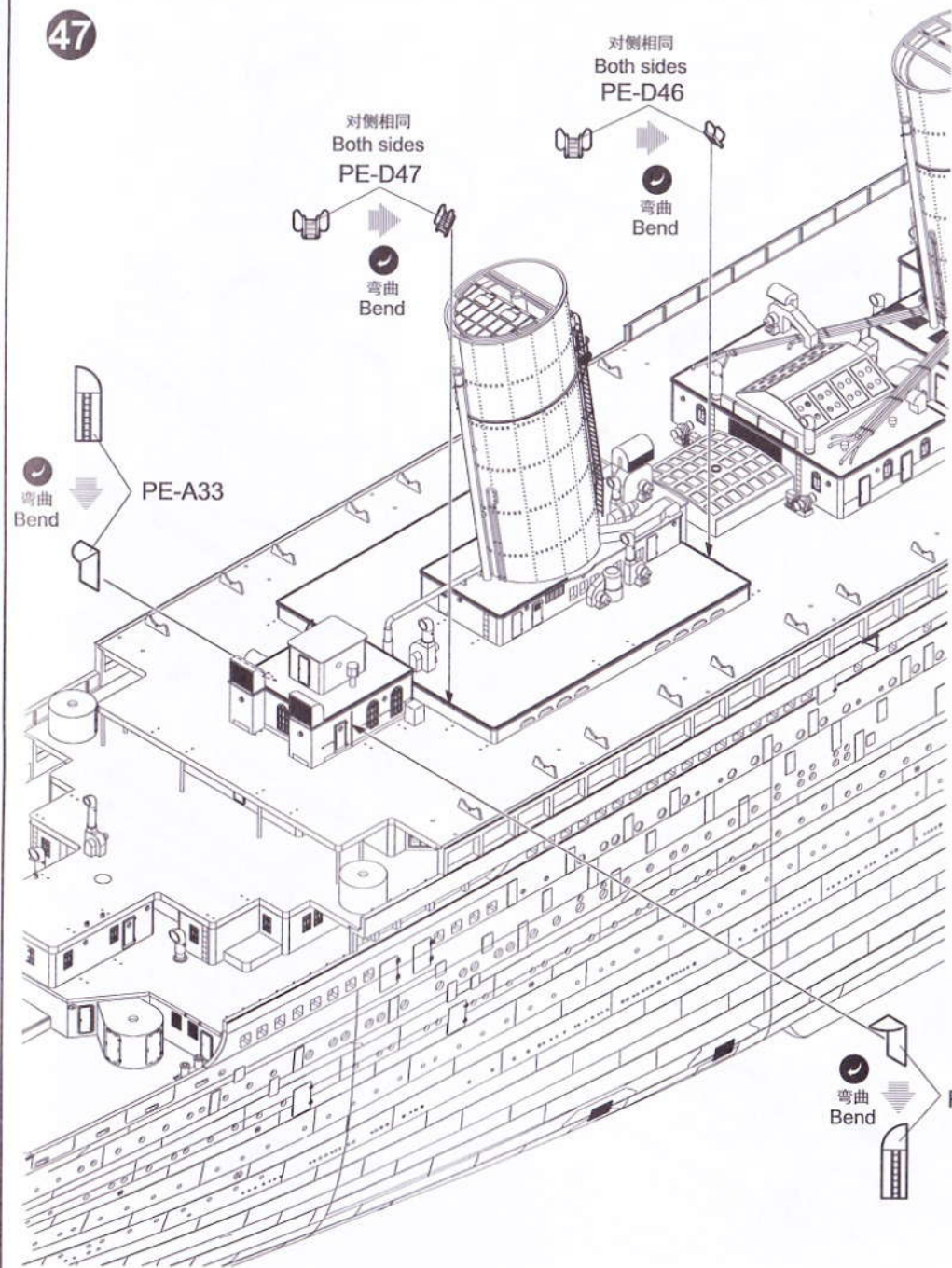

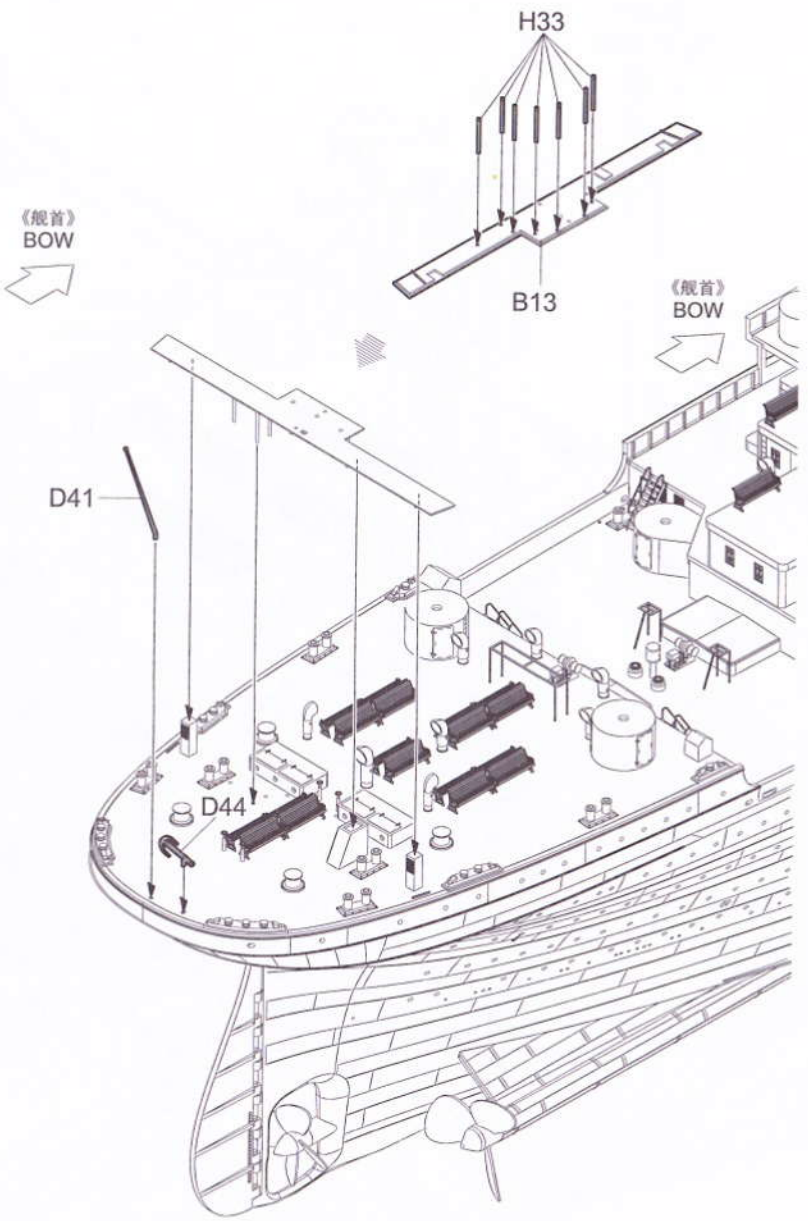
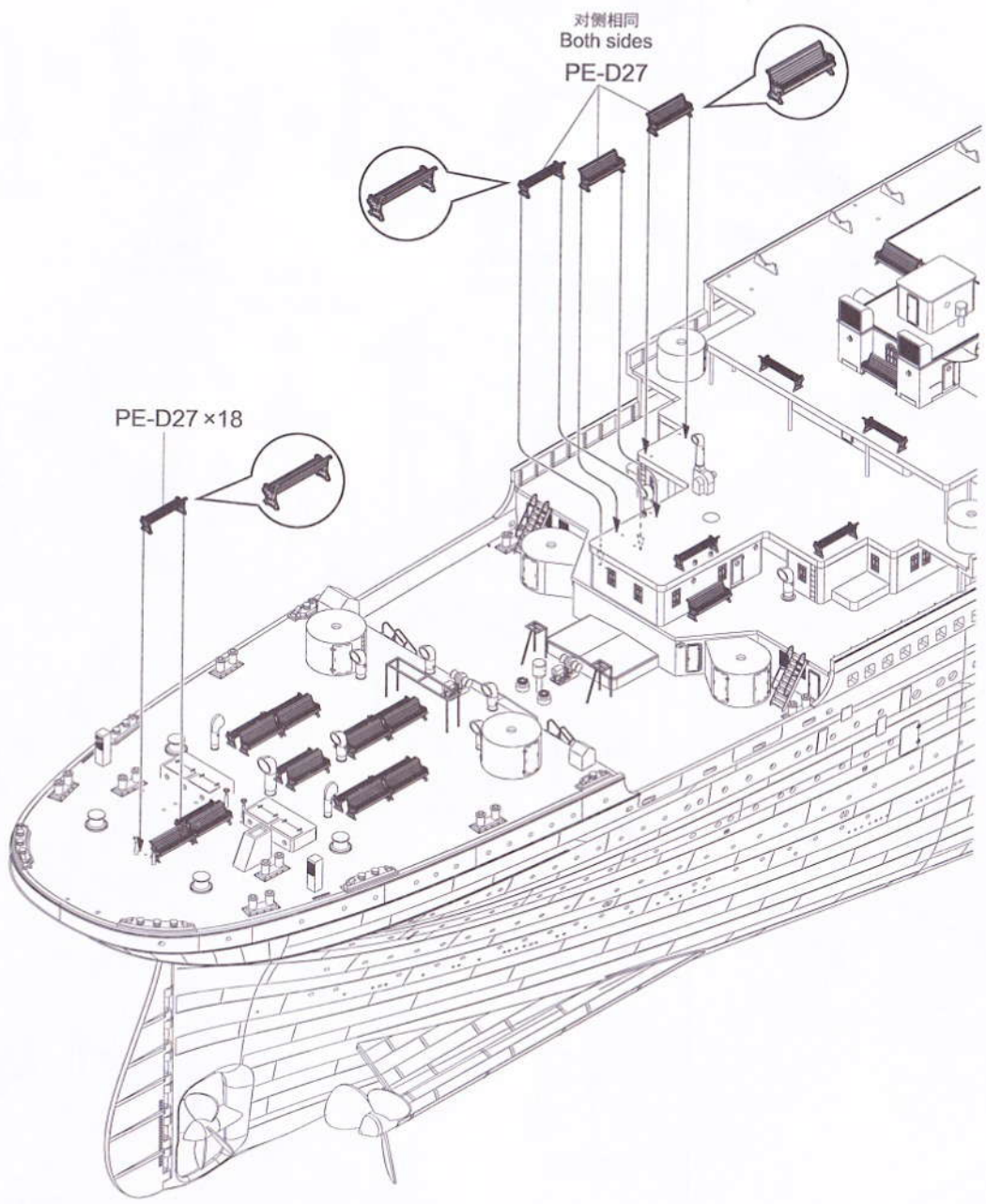

50

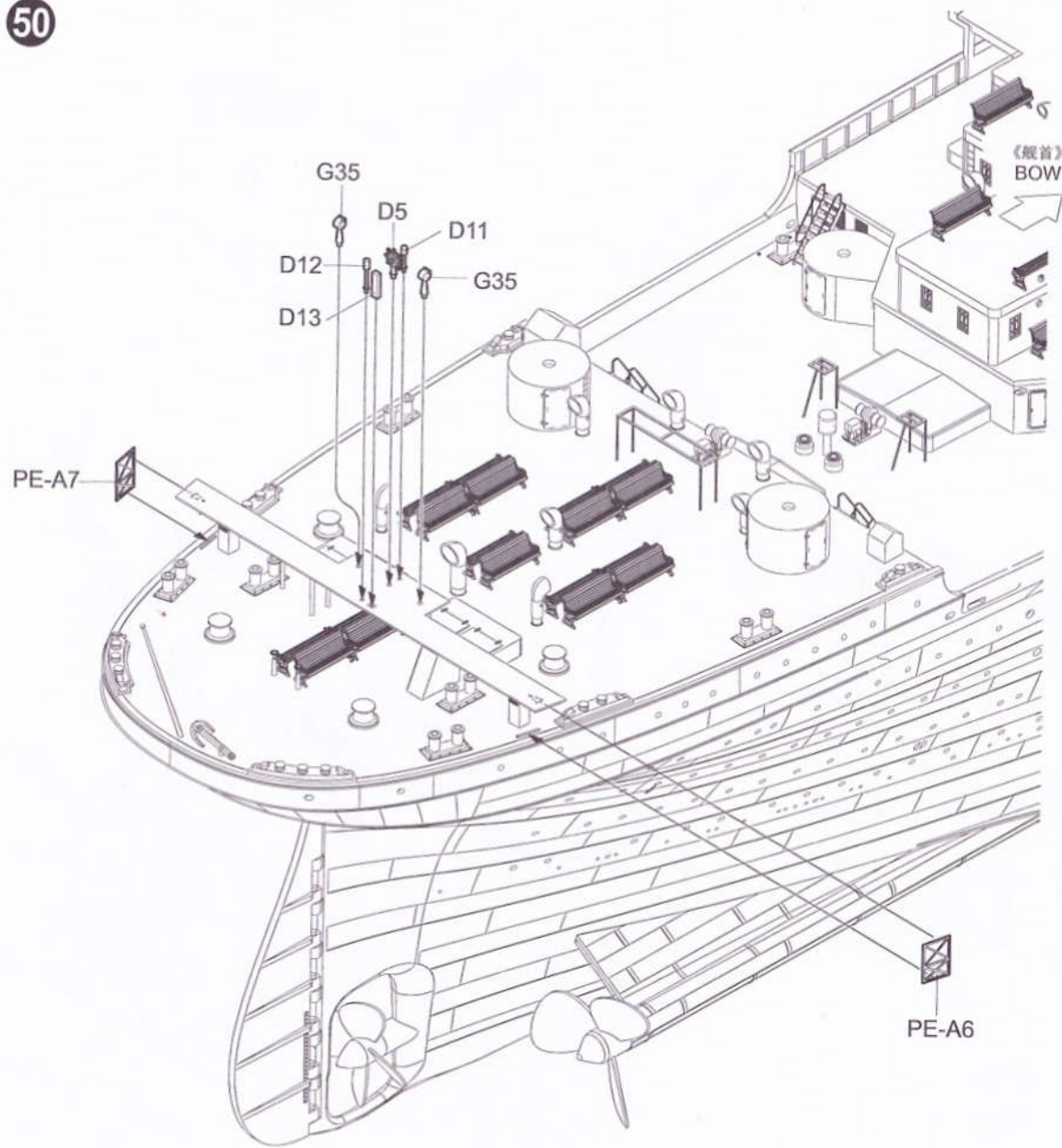

51

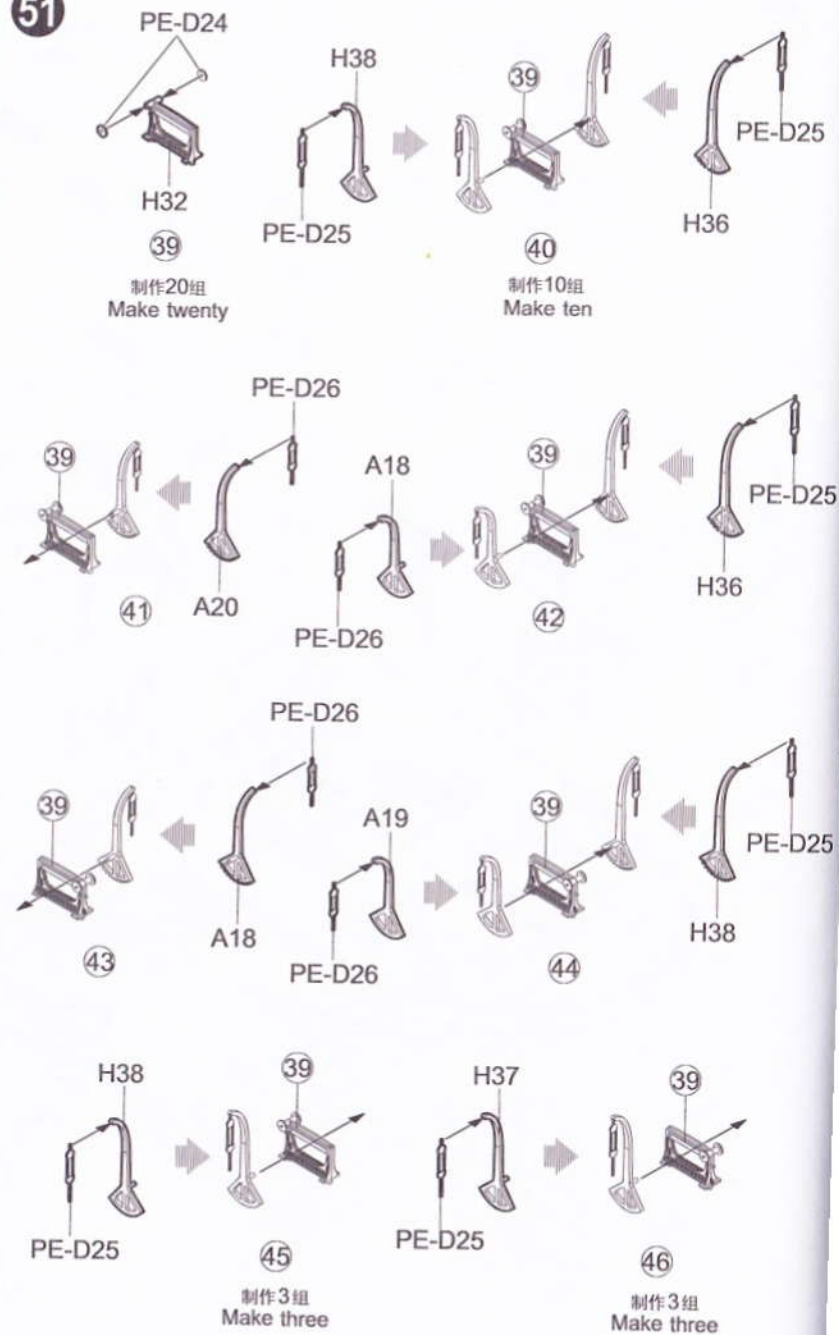

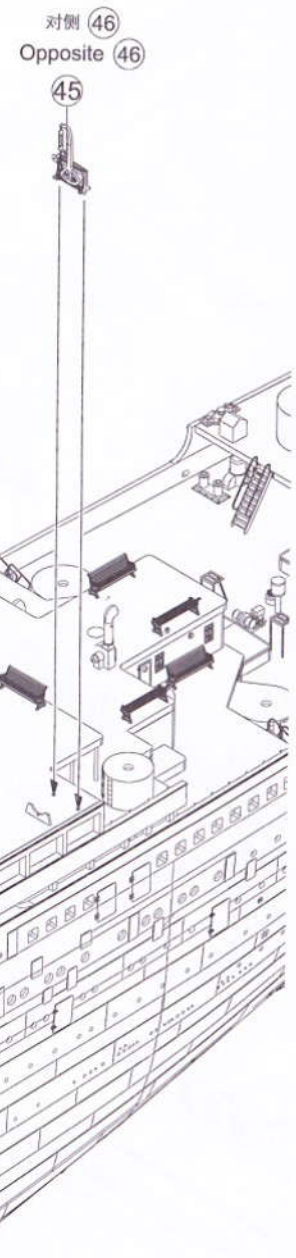
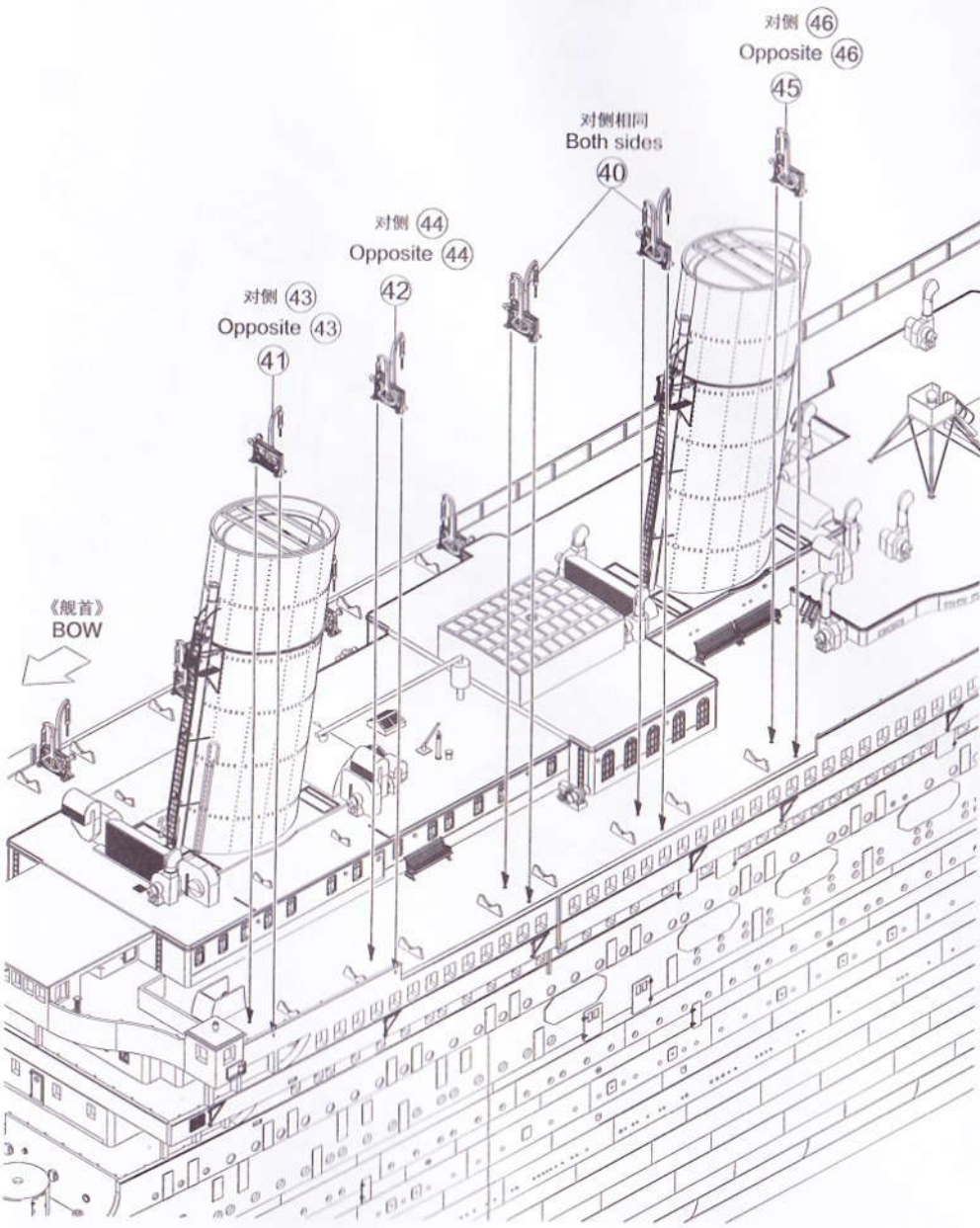

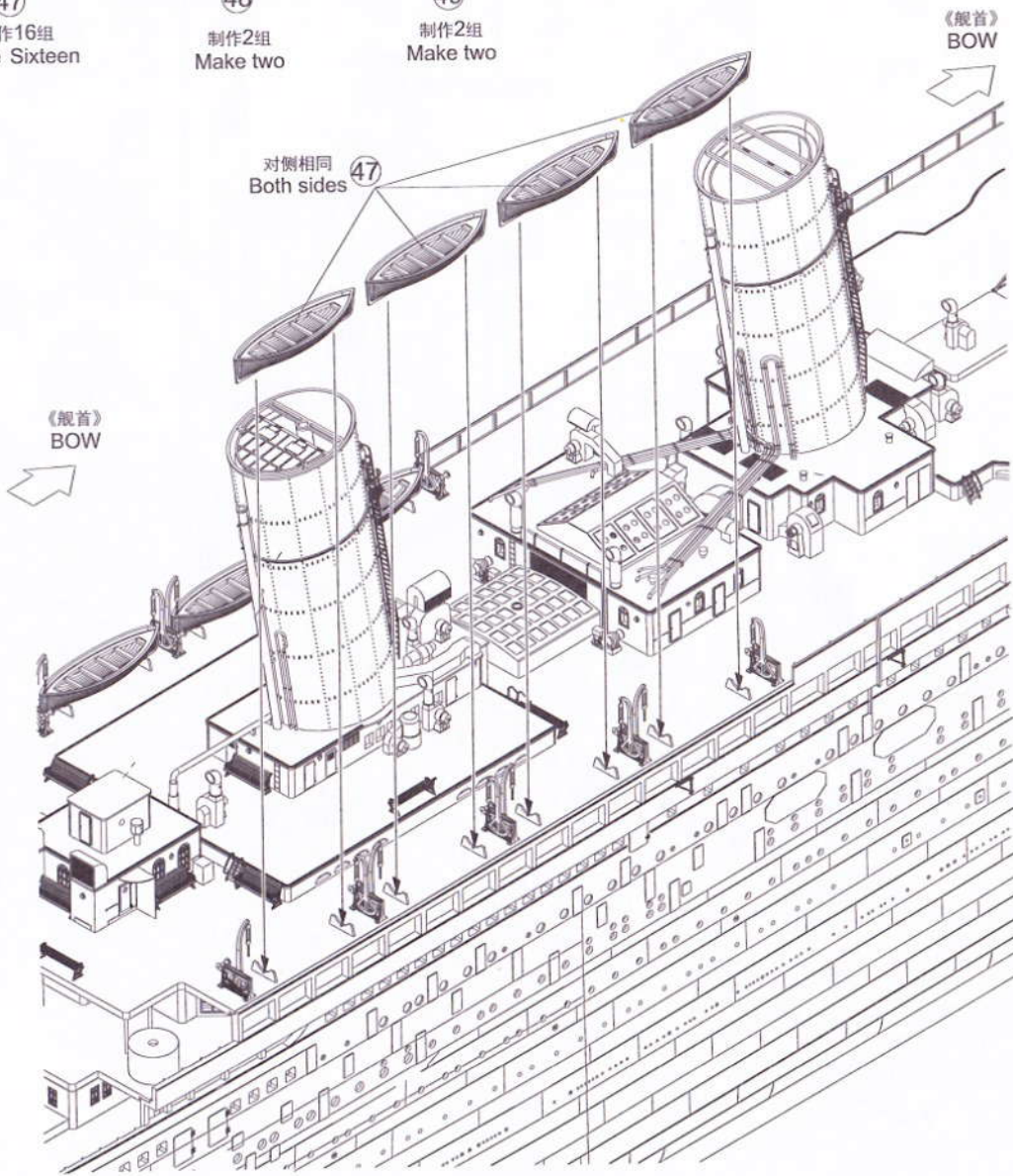
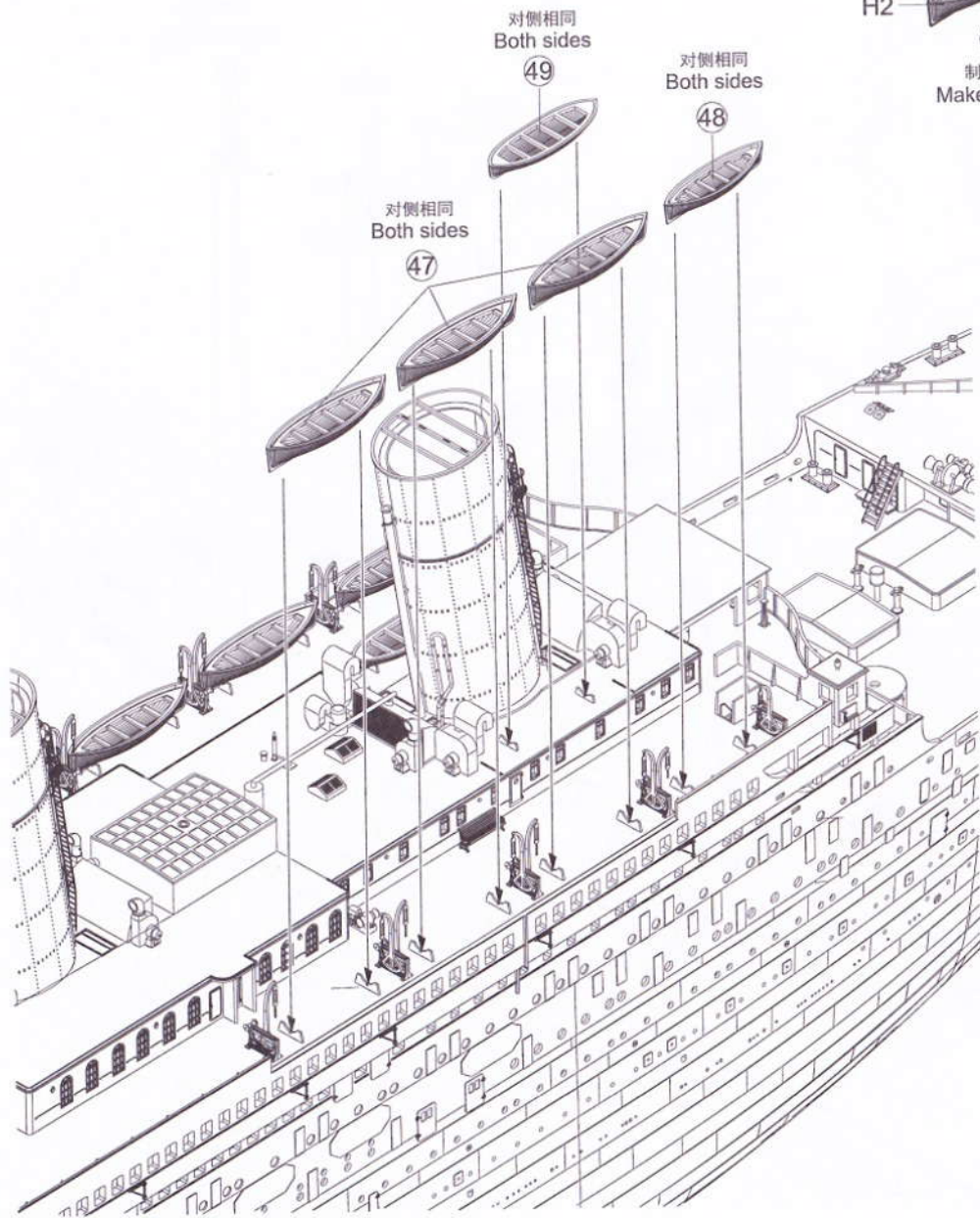
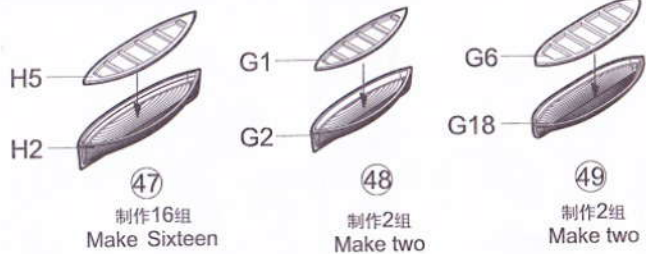

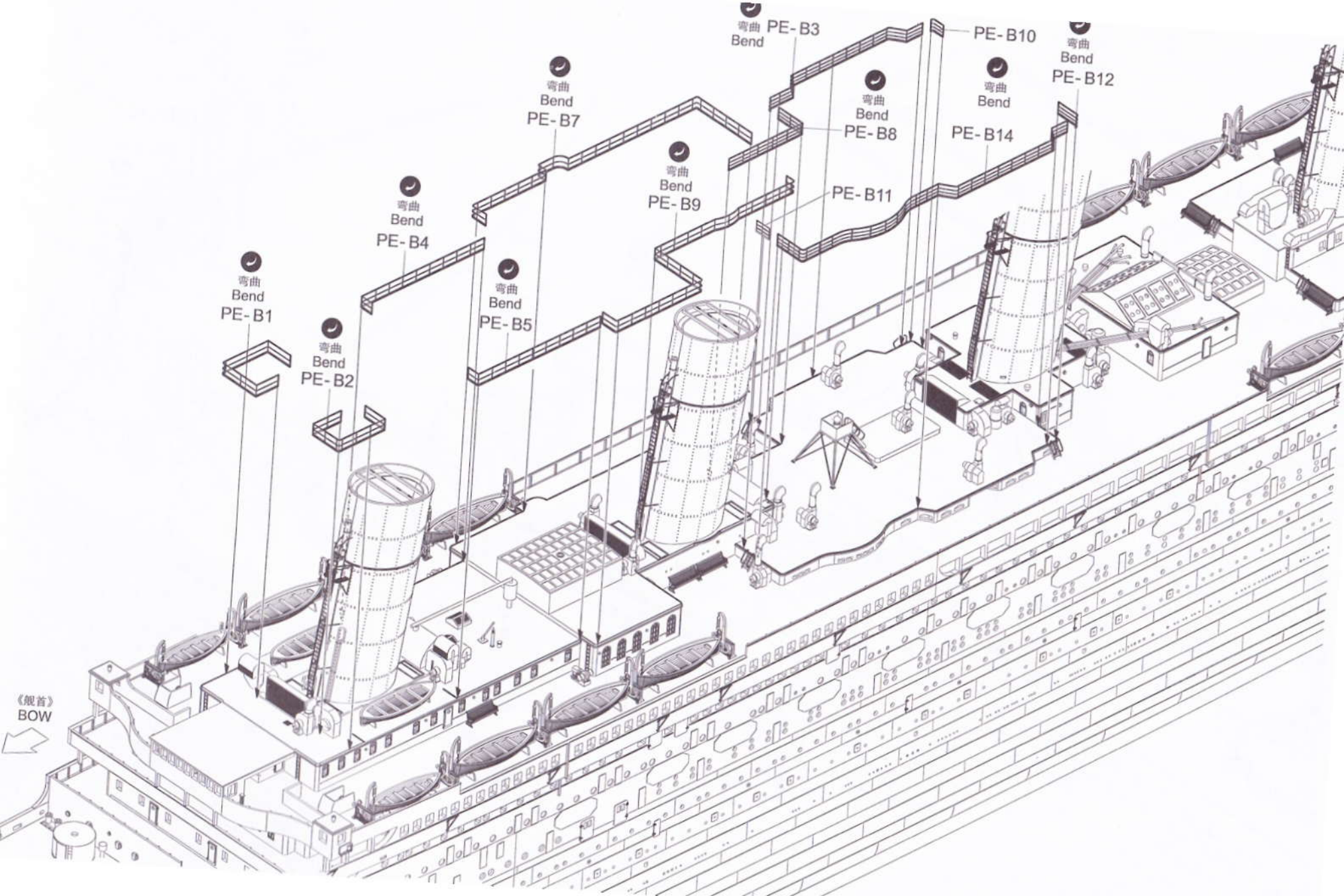

55

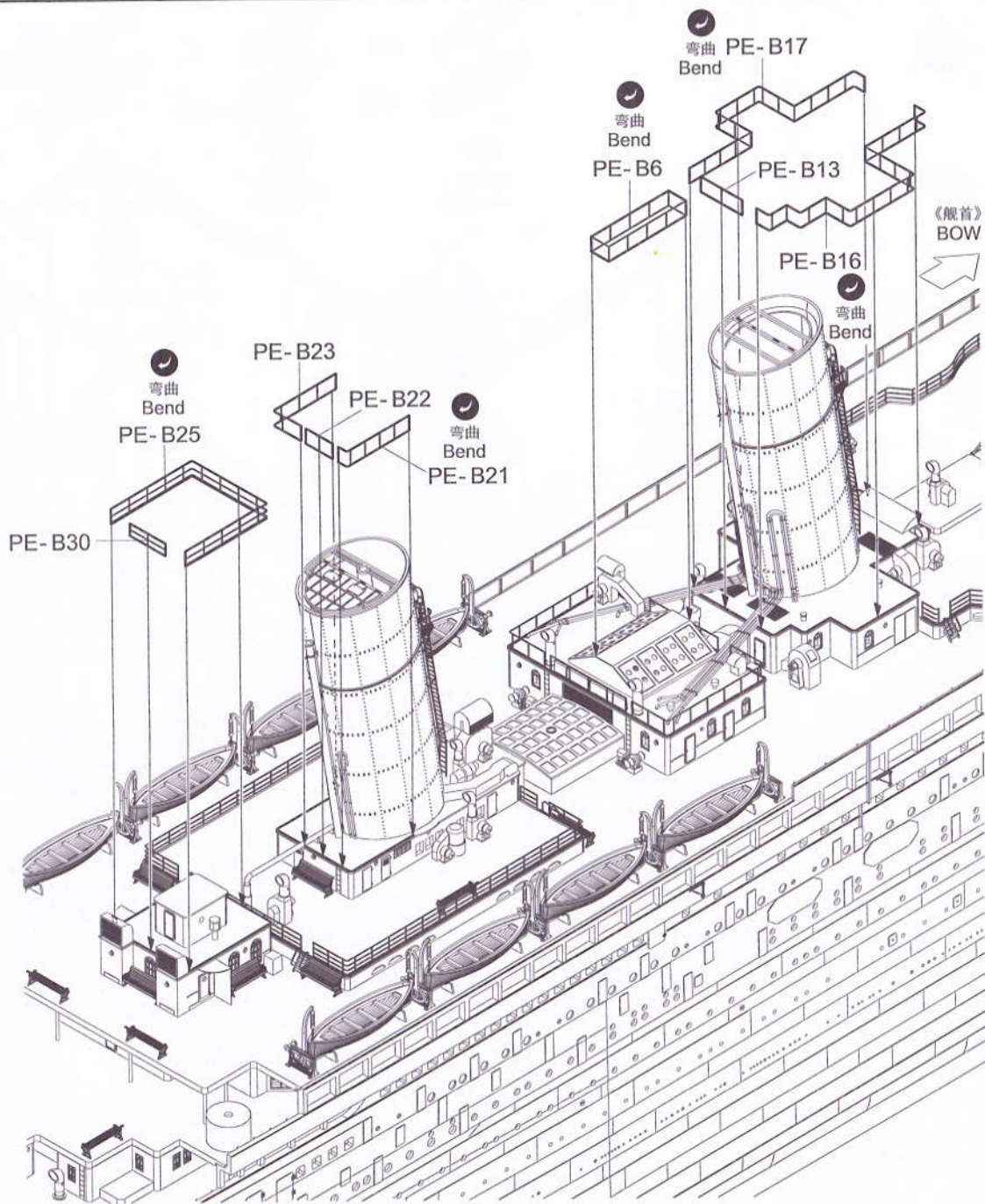
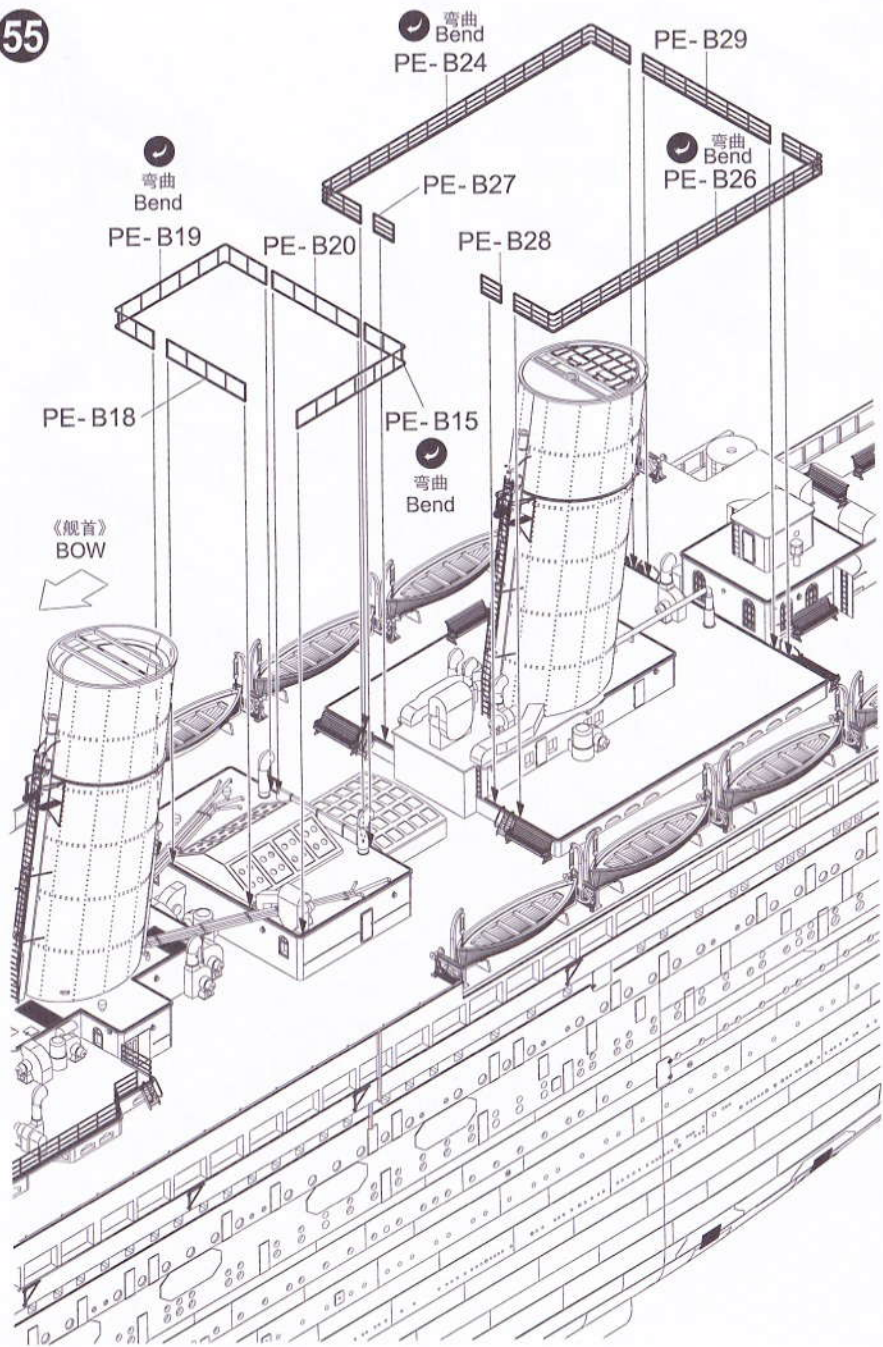

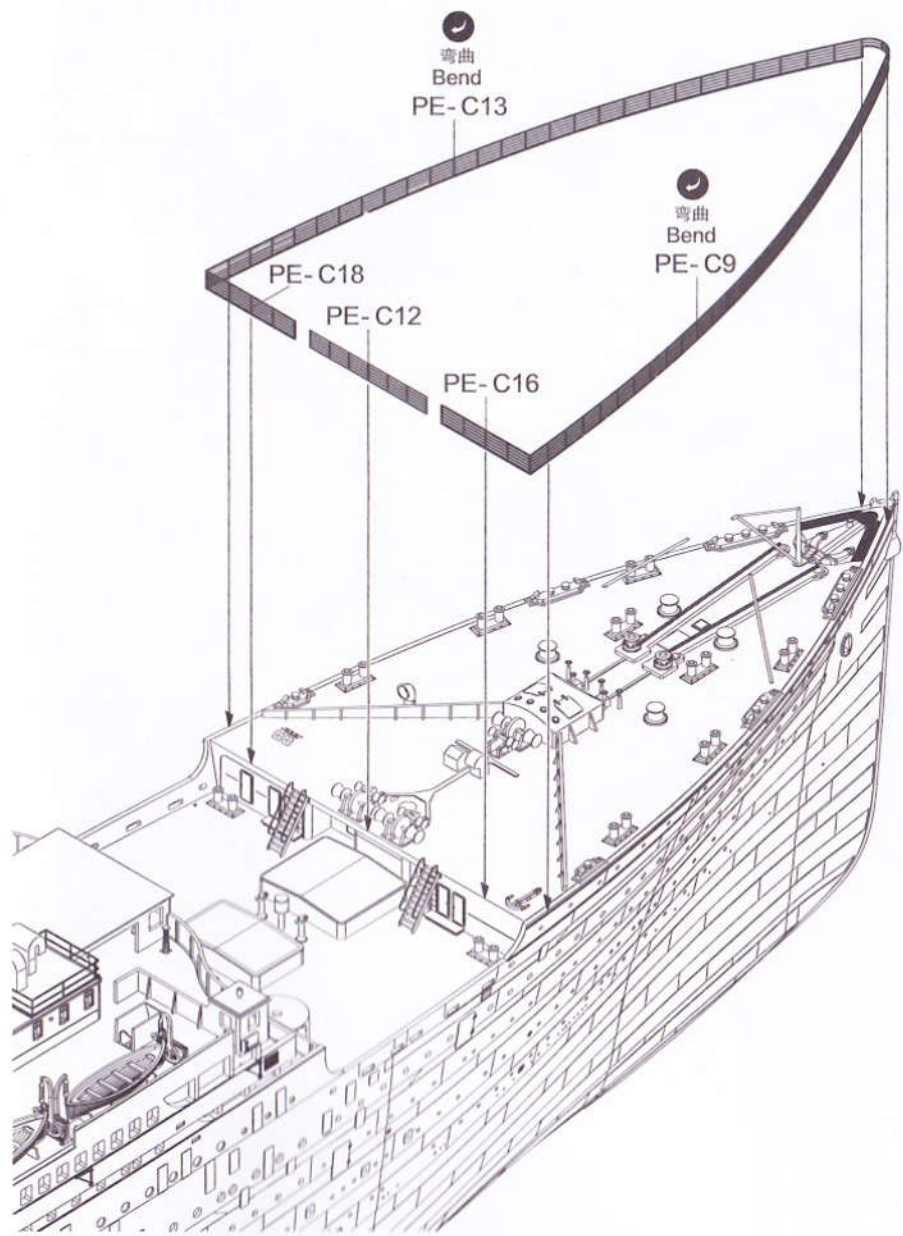

《舰首》
BOW

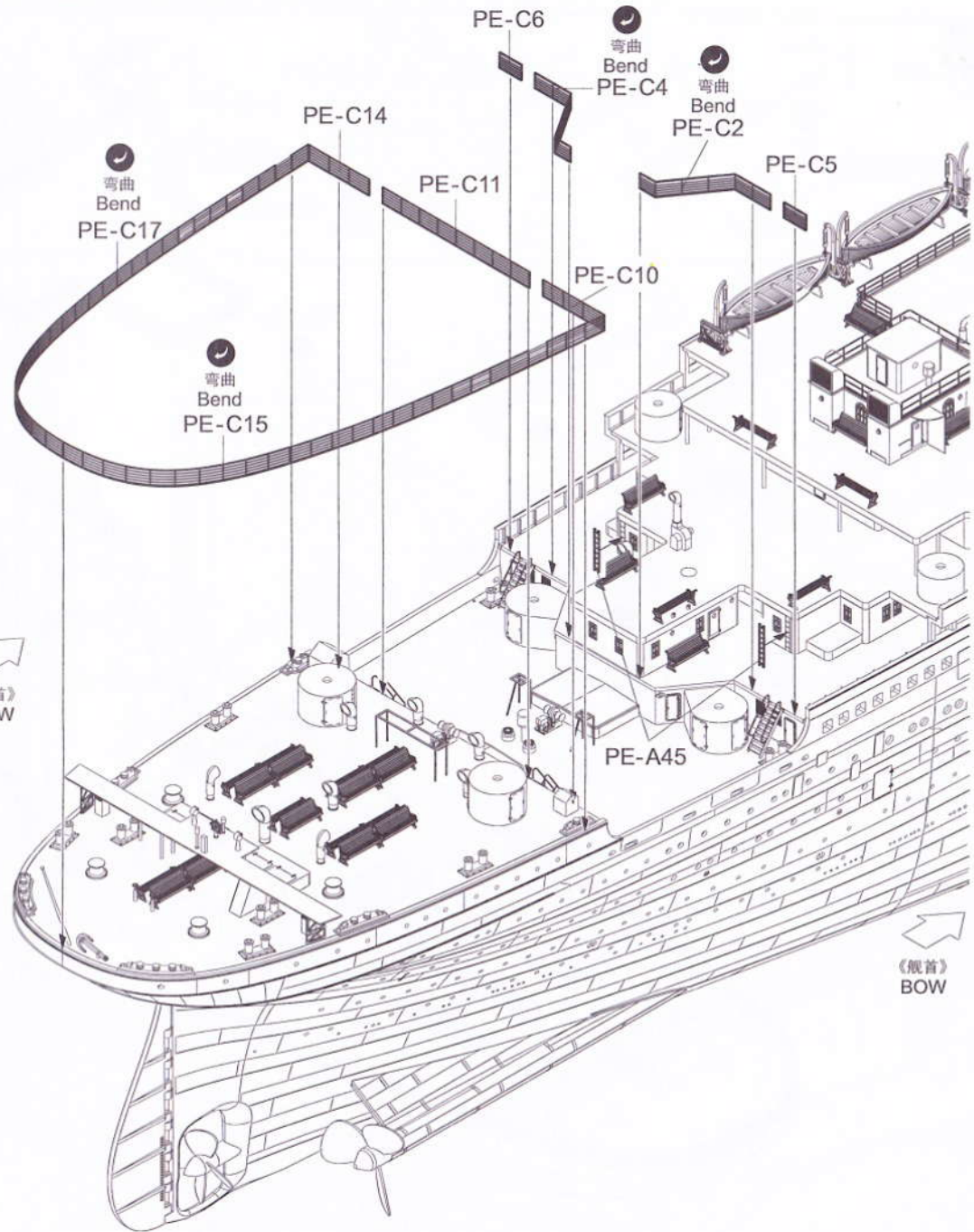

《舰首》
BOW

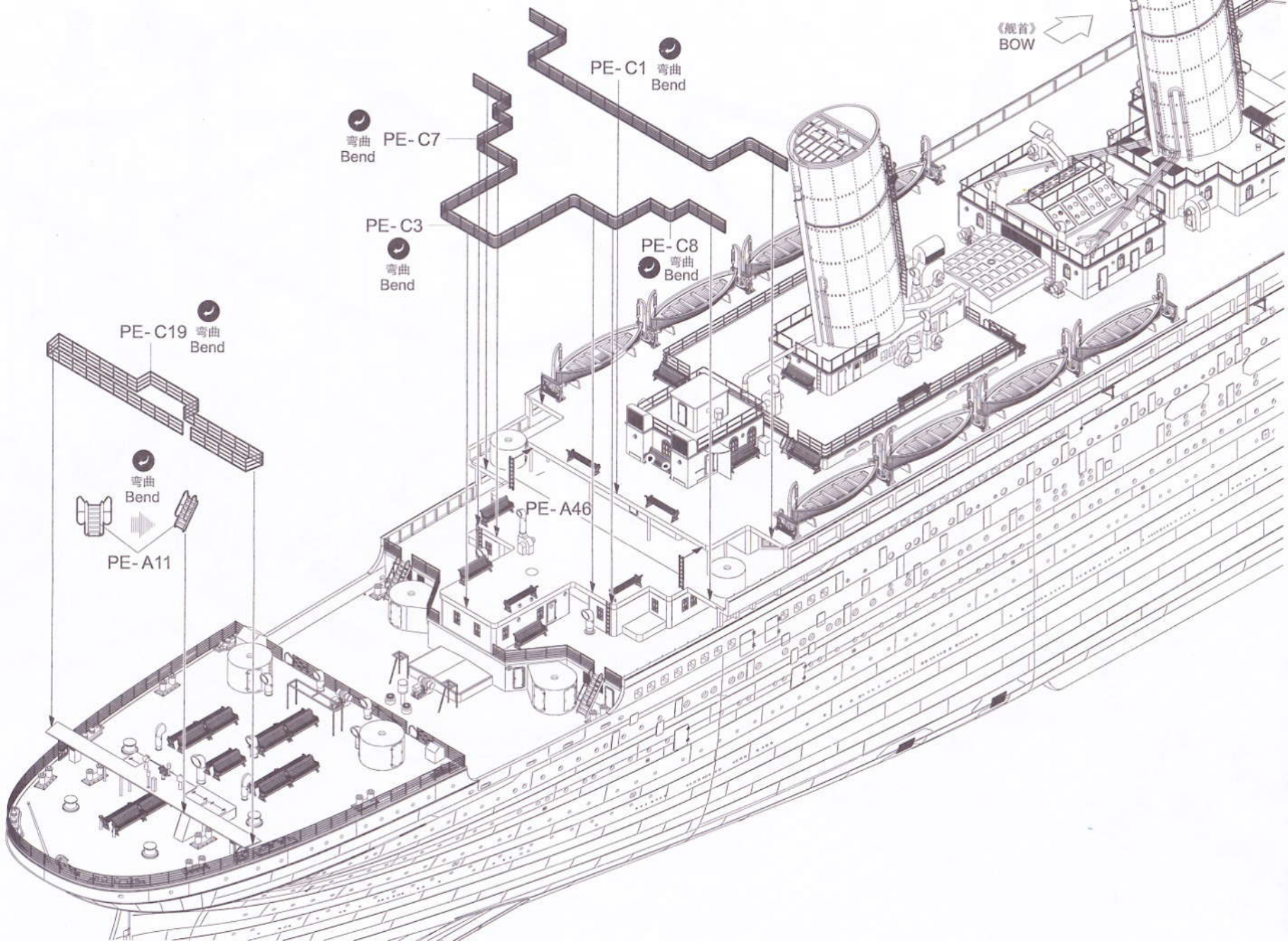

《船首》
BOW

PE-C1
弯曲
Bend

PE-C7
弯曲
Bend

PE-C3
弯曲
Bend

PE-C8
弯曲
Bend

PE-C19
弯曲
Bend

PE-A11
弯曲
Bend

PE-A46

58

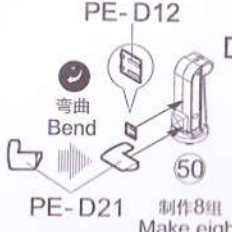
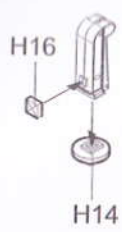
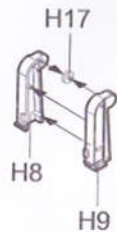

制作8组
Make eight

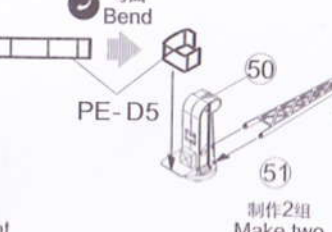

制作2组
Make two

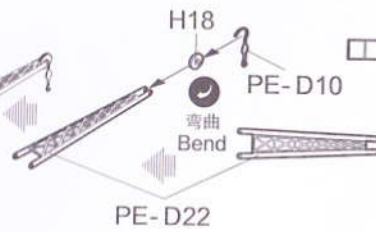

制作6组
Make six

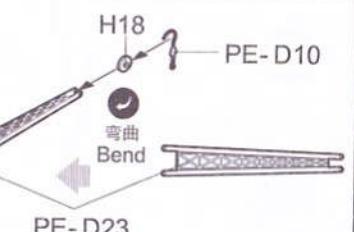
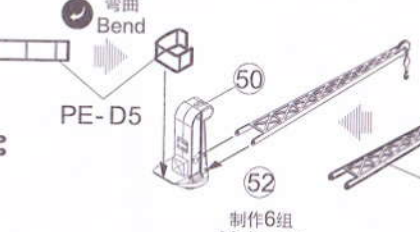

59

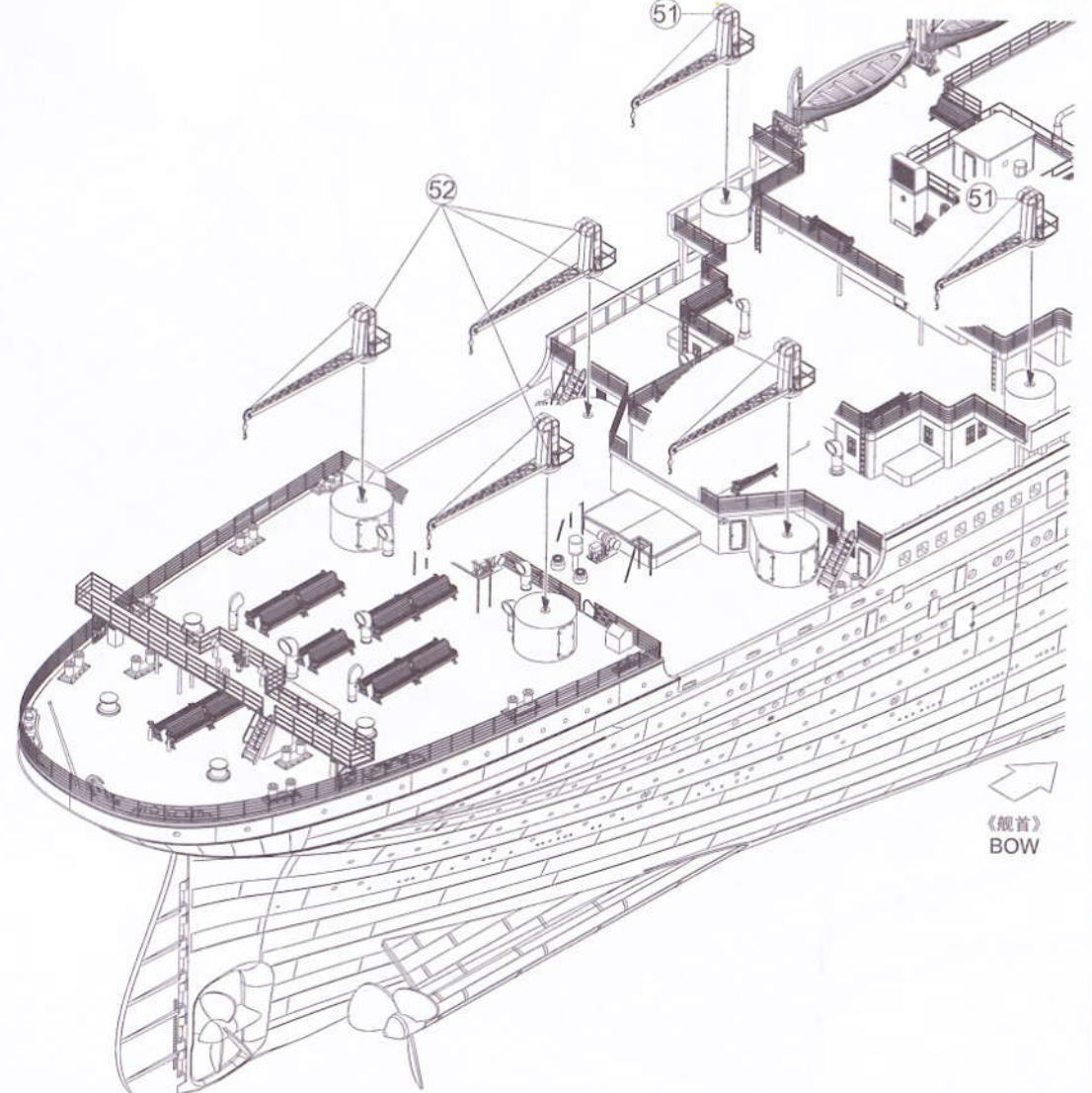
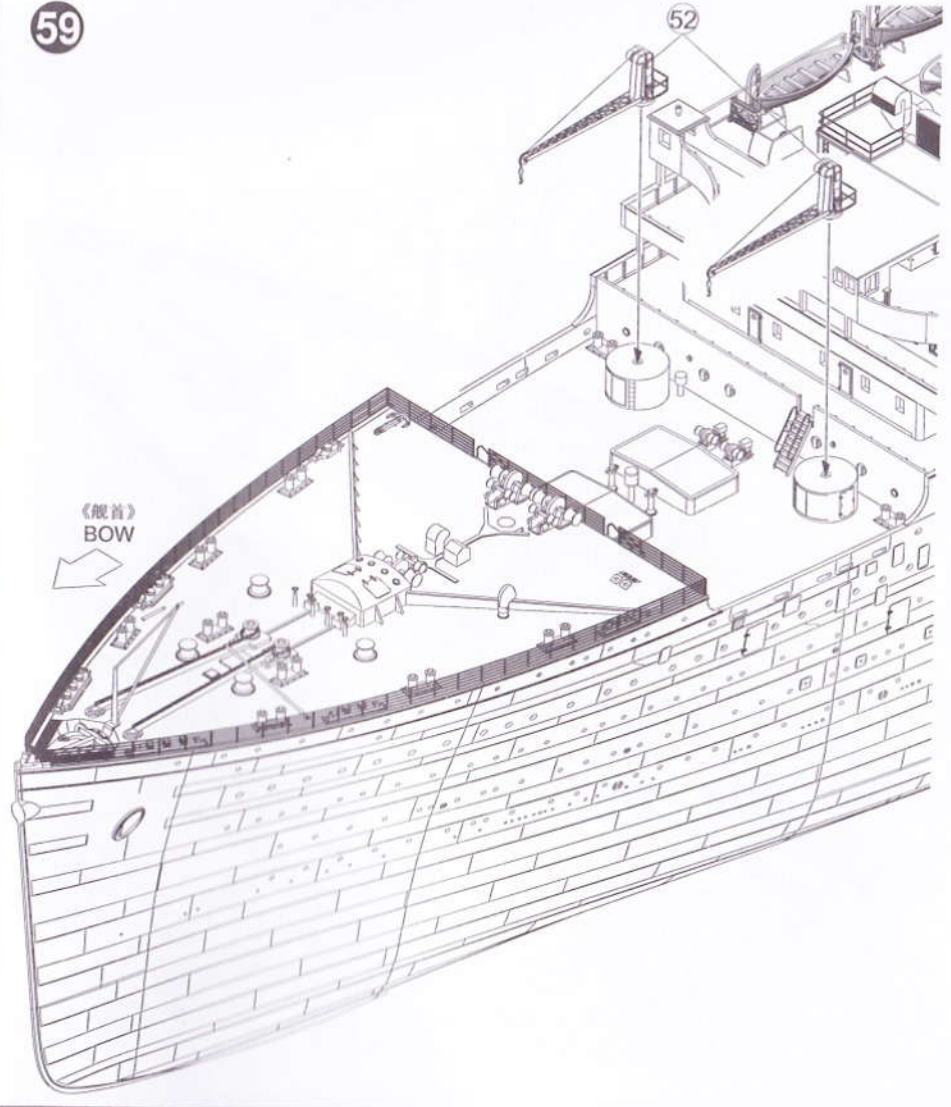

60

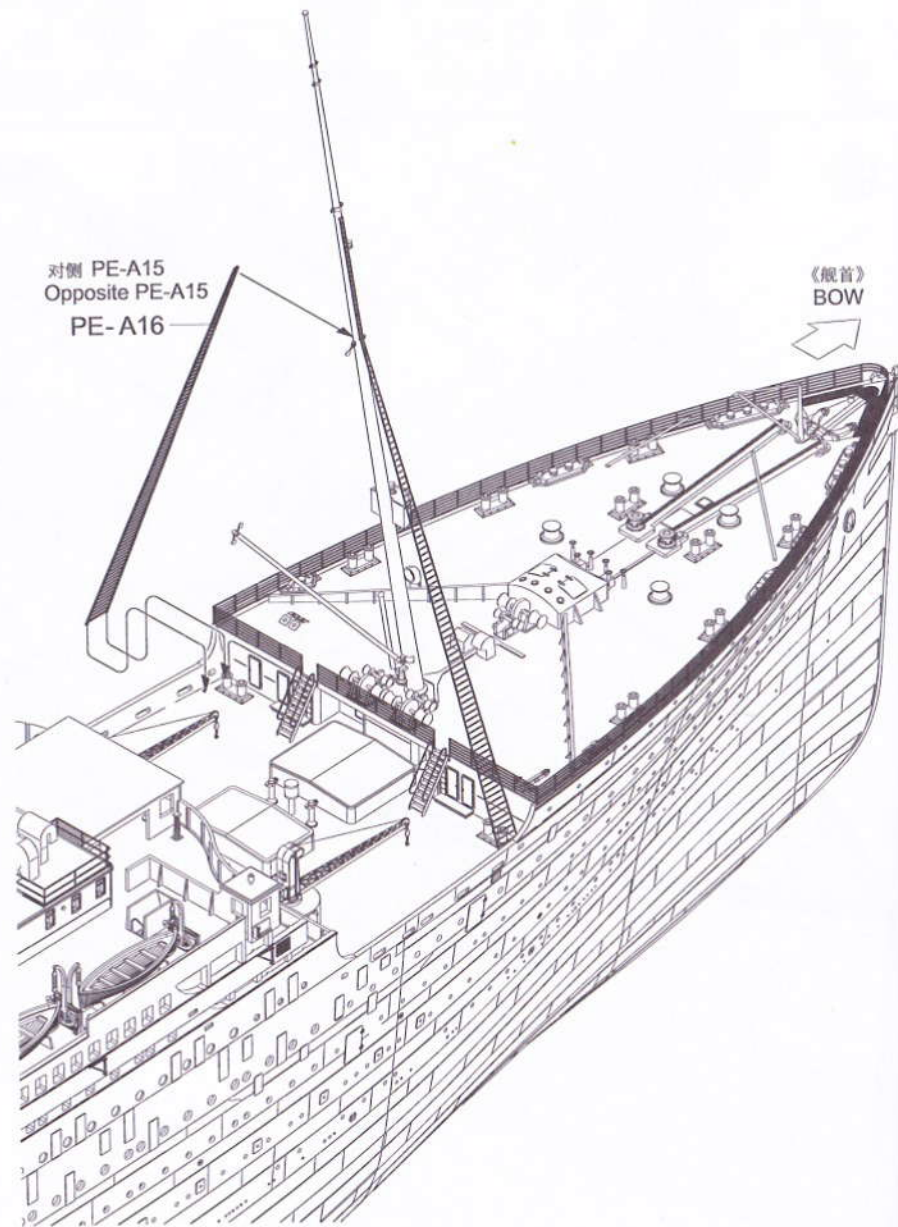
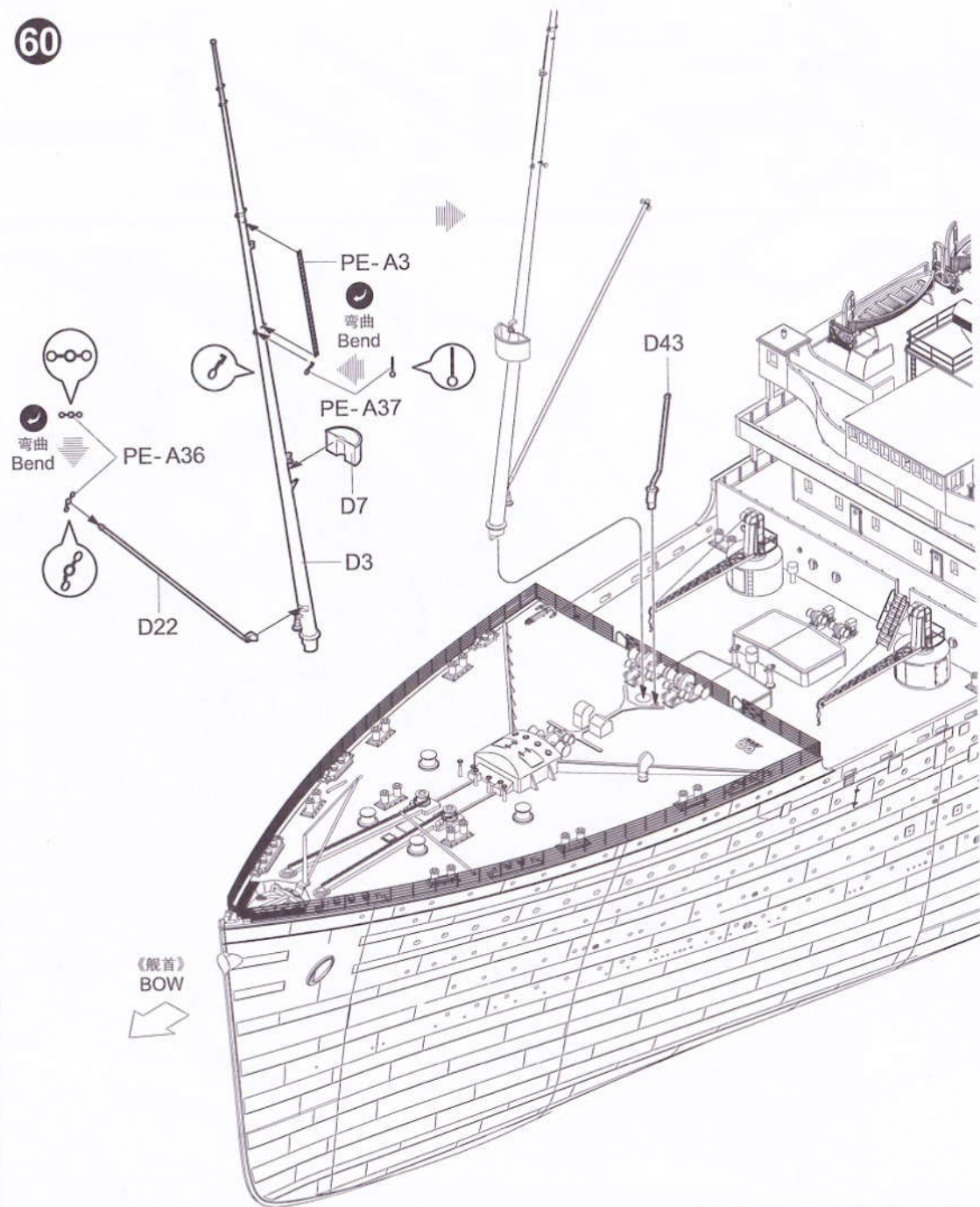

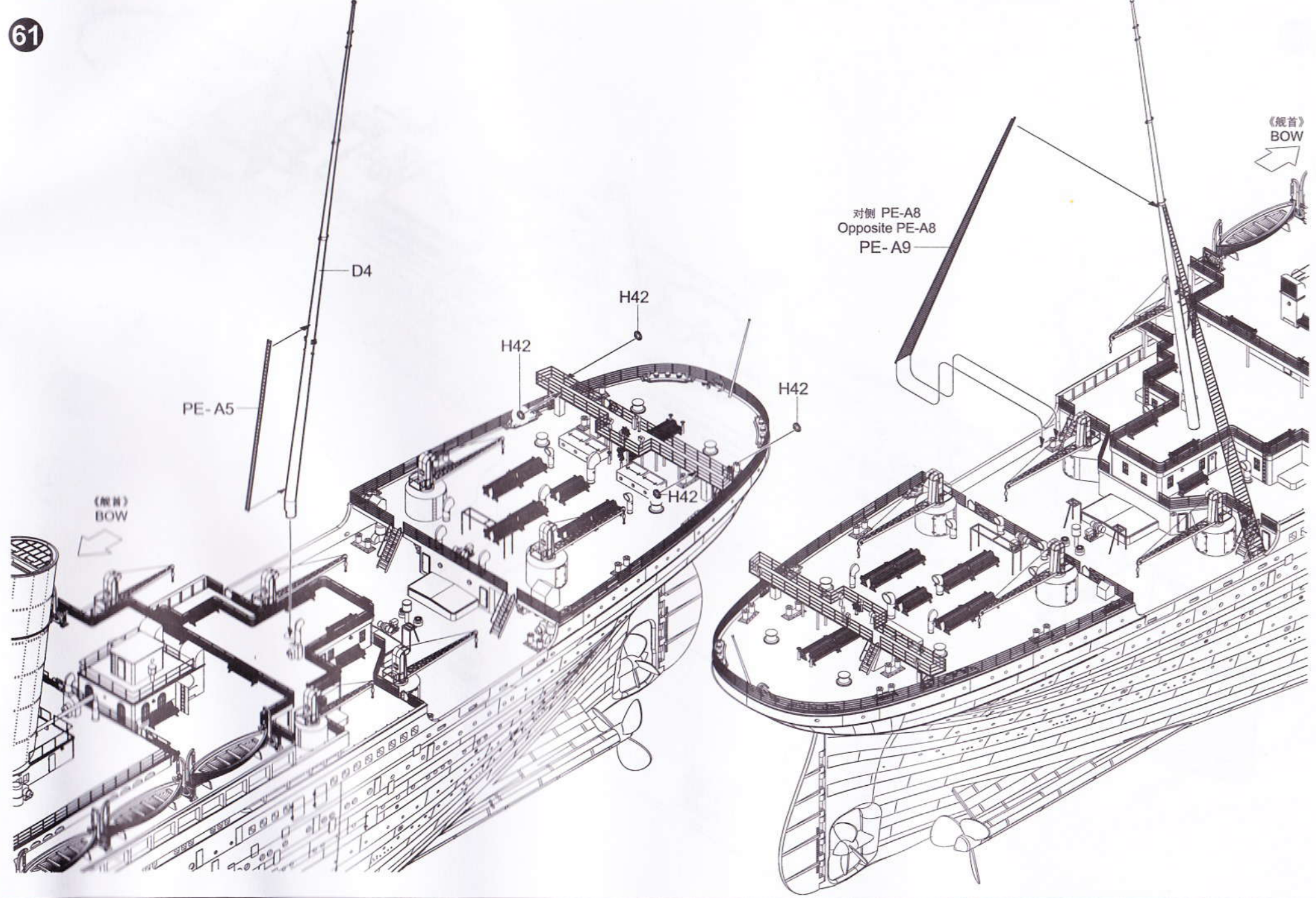

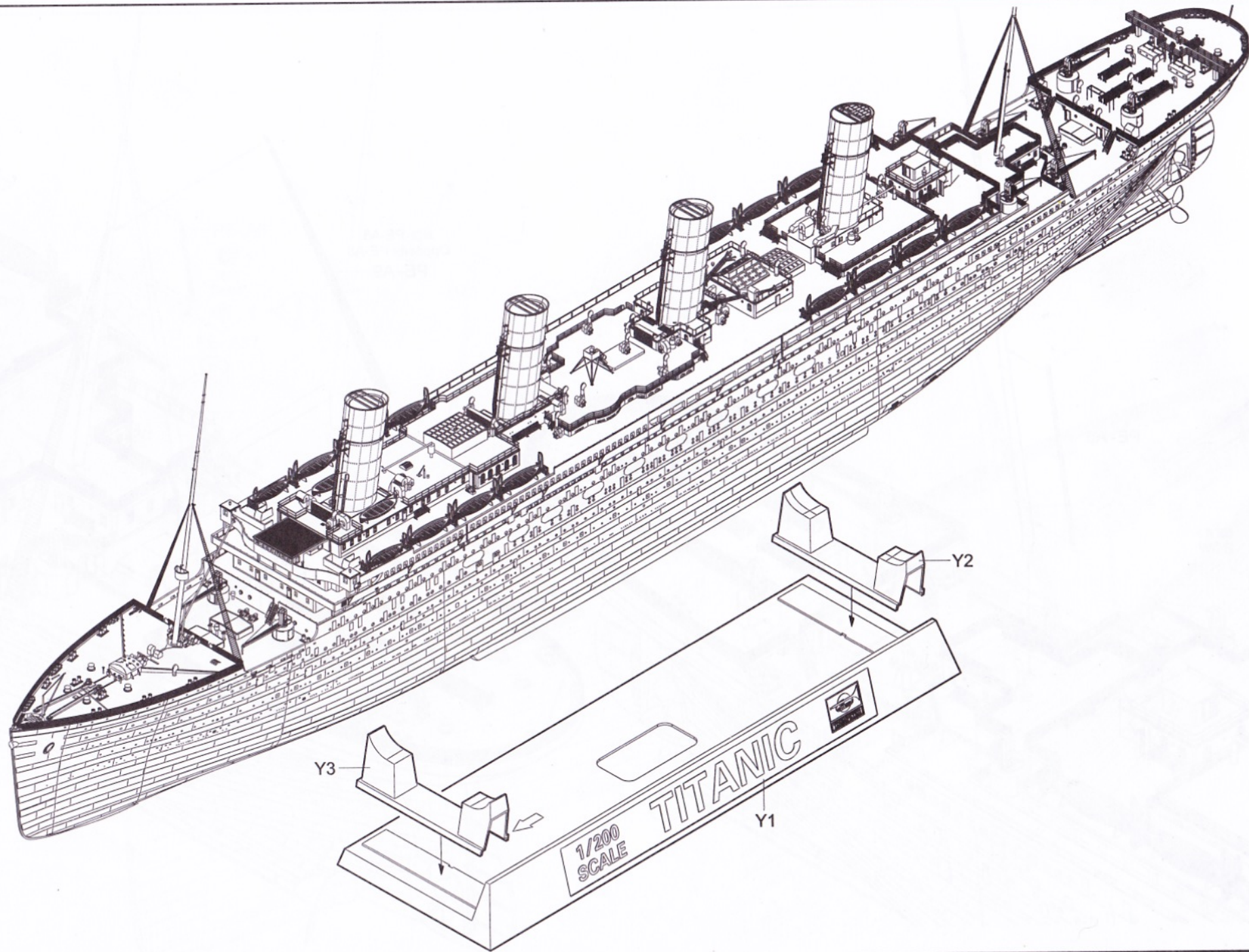

1/200 SCALE MODEL KIT TITANIC 泰坦尼克

FOR: Item 03719

灯光安装指示图

LED ASSEMBLING GUIDE



Customer service email: info@trumpeter-china.com

部品图

Parts

灯带 (6m)
LED Band (6m)



USB 开关线
USB Wire W/Switch



插头线 80mmx10
Wire with plug



插座线 120mm x9
Wire with socket



插座线 300mmx1
Wire with Socket



红线(1m)
Red wire (1m)



黑线 (1.2m)
Black Wire (1.2m)



热收缩套管 50mmx1
Heat Shrinkable Tube



碳膜电阻 x28
Resistance

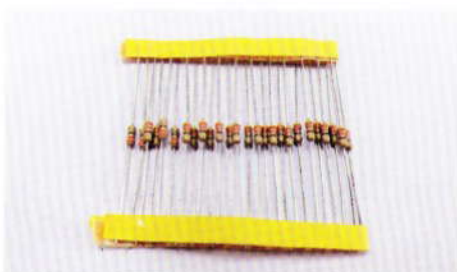

LED-黄 x26
Yellow LED



LED-红(有边) x1
Red LED (Edged)



LED-绿(无边) x1
Green LED (Borderless)



1 灯带剪切时要在两灯之间的“小剪刀”处剪切(如下图)
When cutting the lamp LED Band, cut it at the "small scissors" between the two lamps (as shown below)

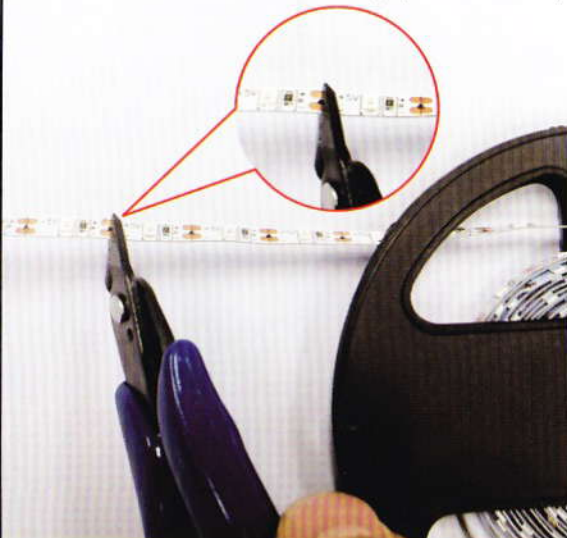

2 船底钻孔
Drill a hole



3 USB 线穿孔过船底
USB Wire through the bottom hole of the hull



4 USB线头在大概15cm处打个结
Tie a knot at 15cm of USB wire

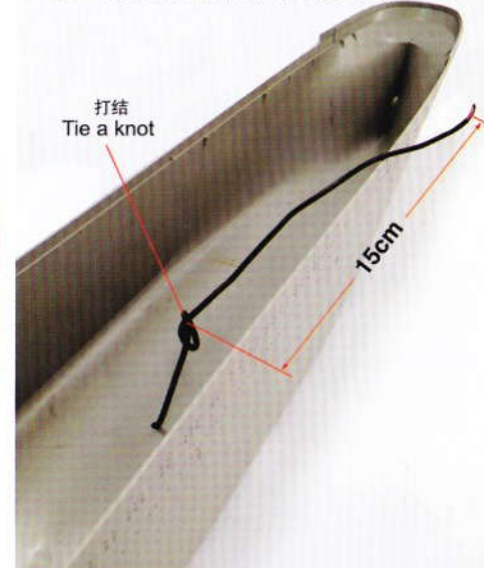

5

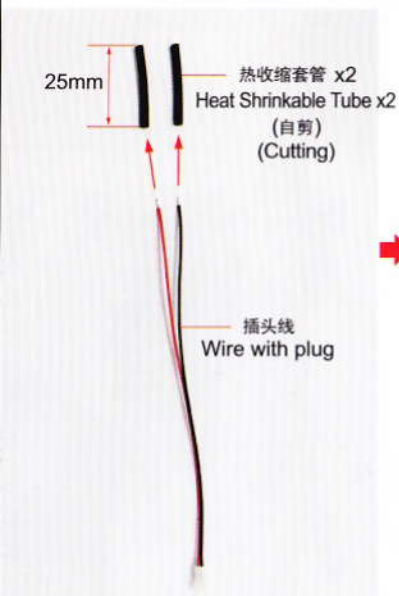

6

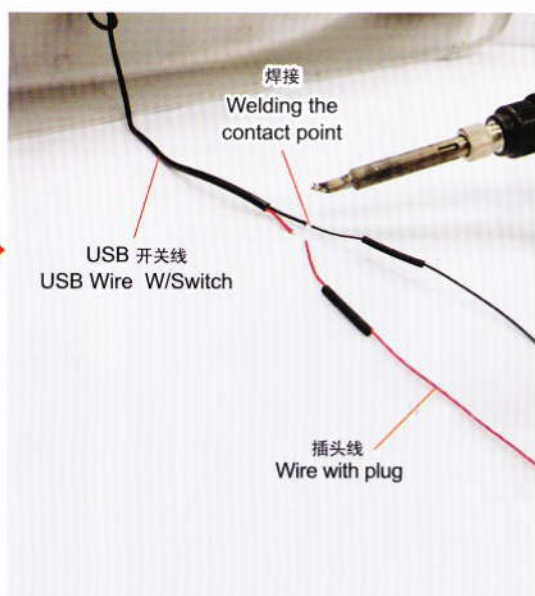

7 把热收缩套管套盖住焊点并轻微加热, 让其收缩。
Cover the welding spot with the heat shrinkable tube and heat it slightly to make it shrink.

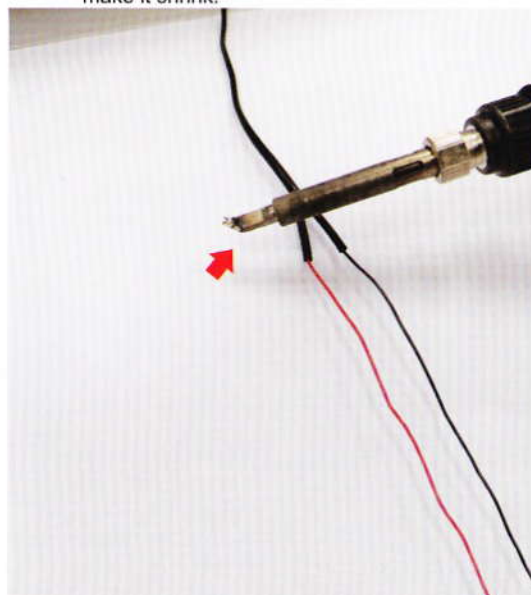

8 贴灯带
Paste LED Band

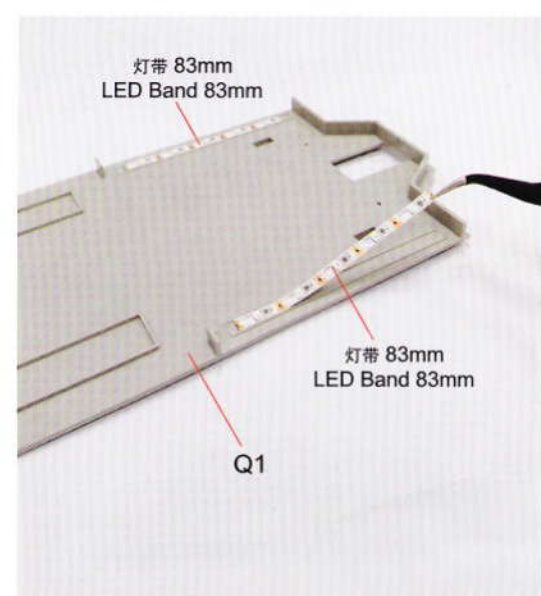

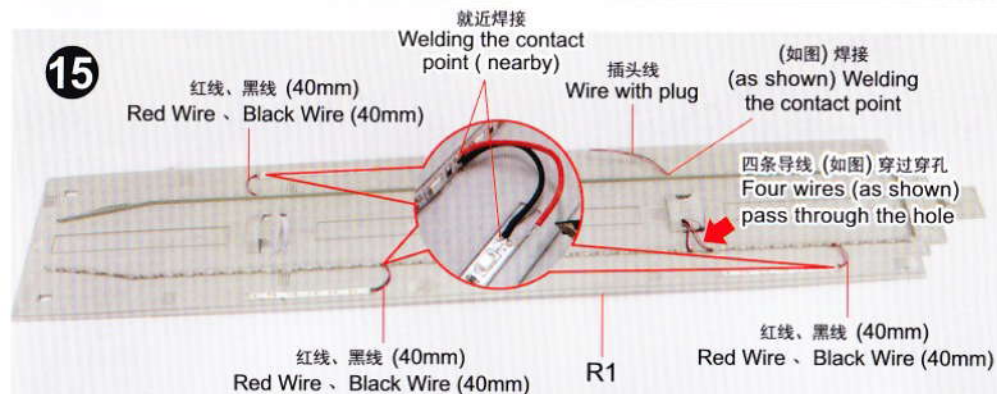
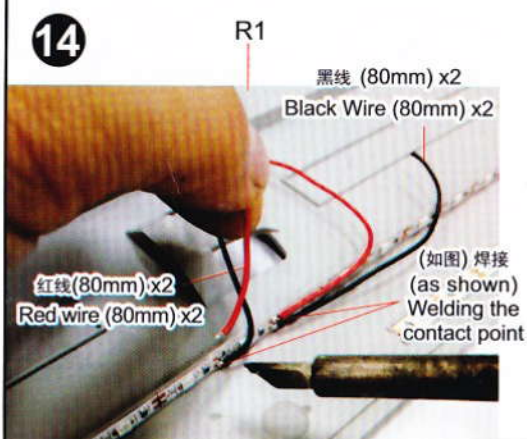
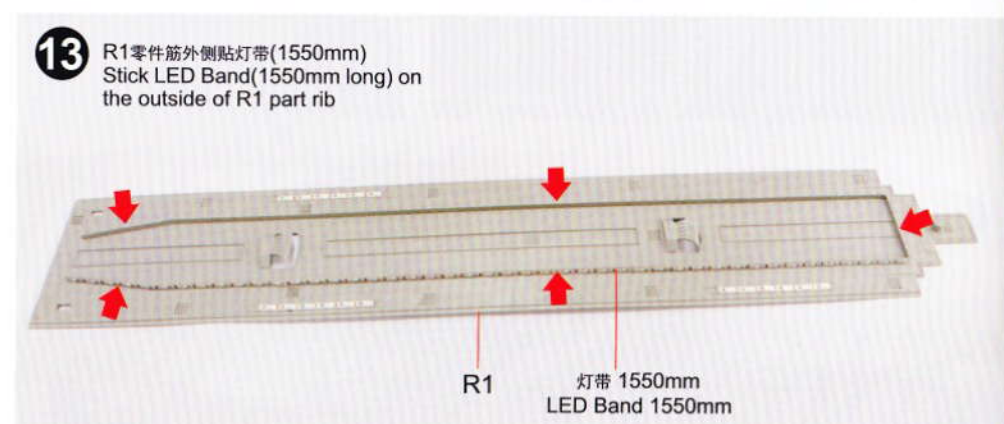
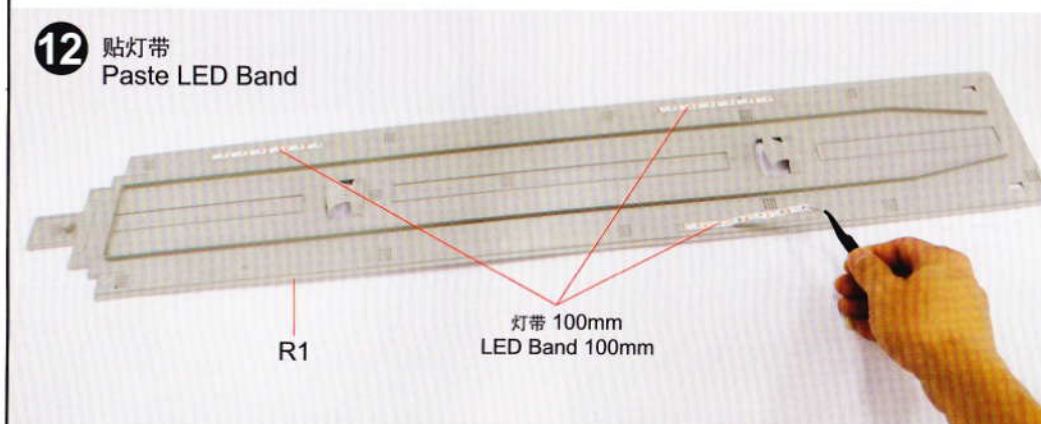
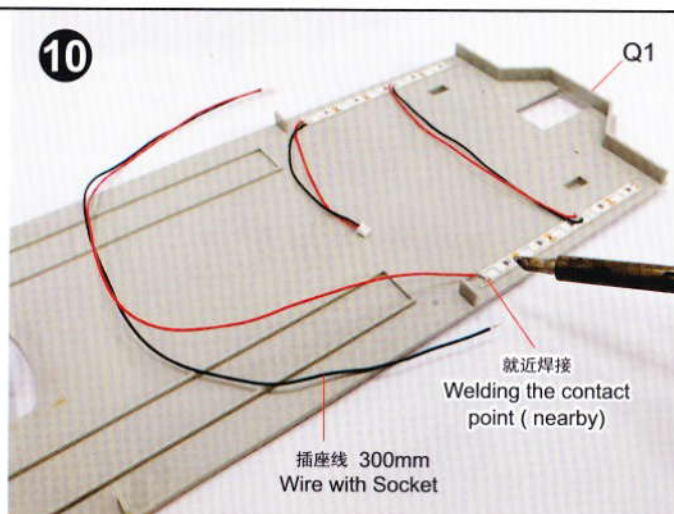
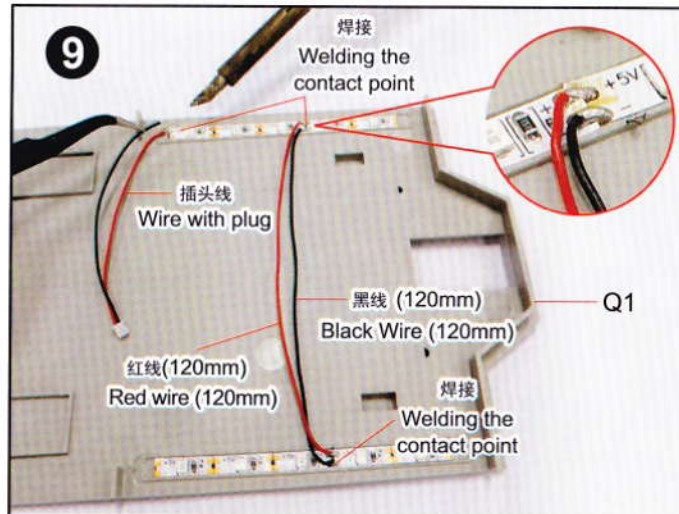

17 贴灯带
Paste LED Band

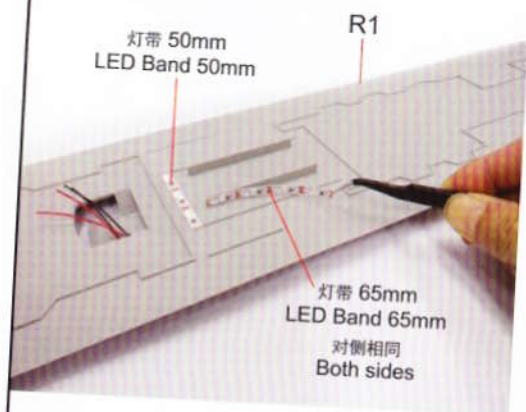

18

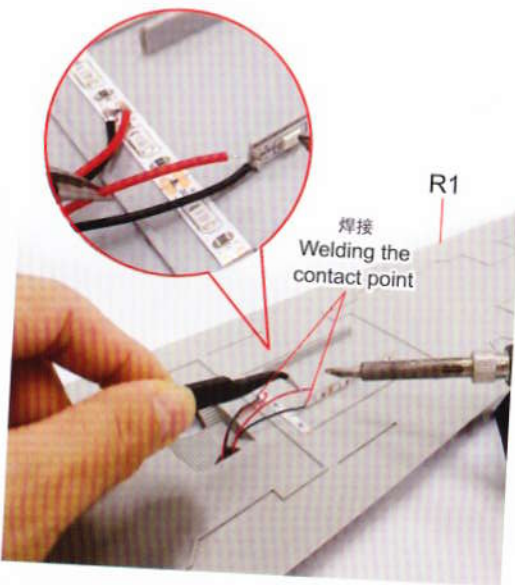

19

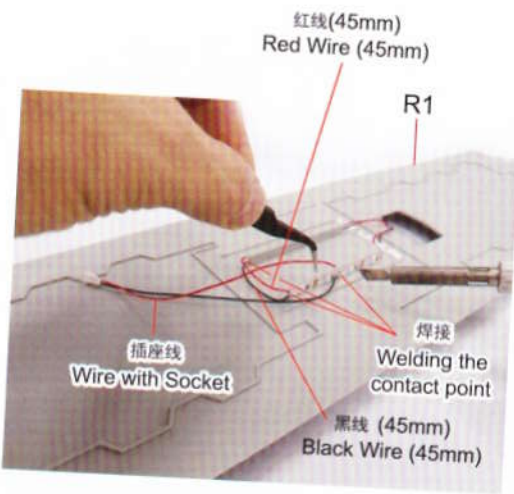

20

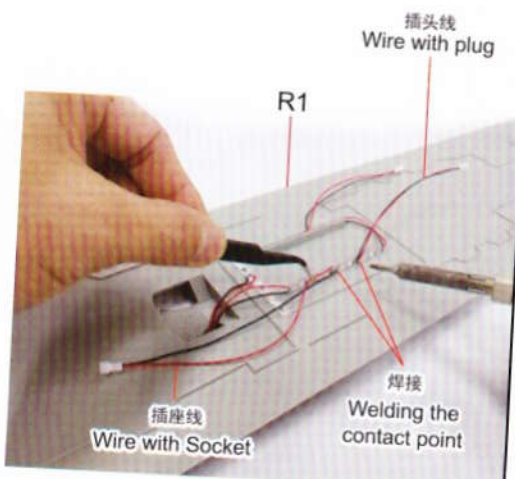

21 打胶固定所有焊接点
Glue and fix all welding points

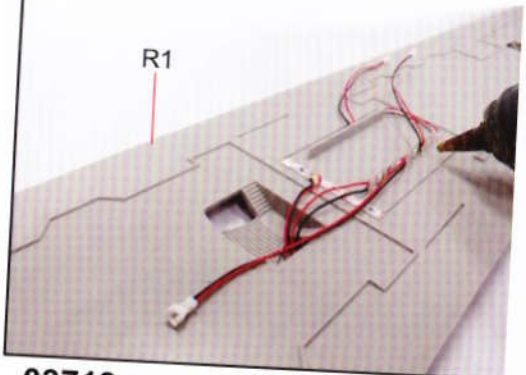

22

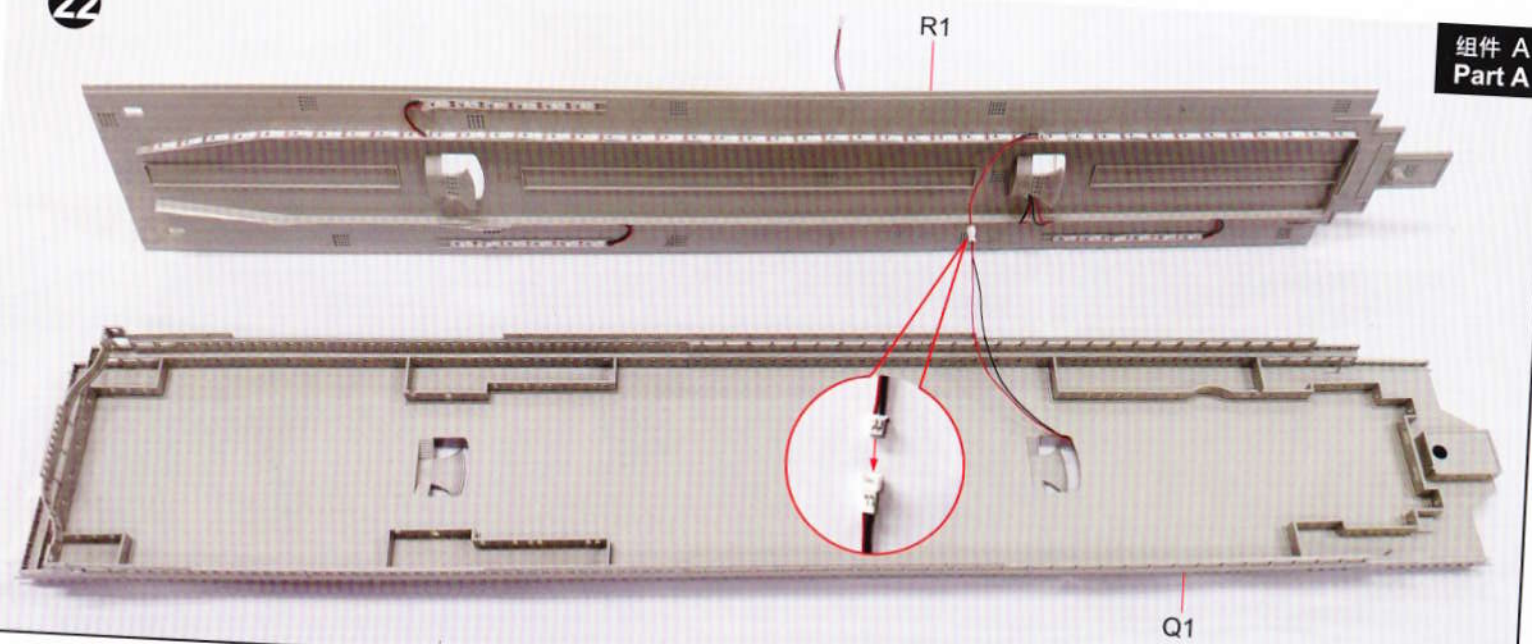

03719

23 T1零件筋外侧贴灯带
Attach LED Band on the outside of T1 part rib

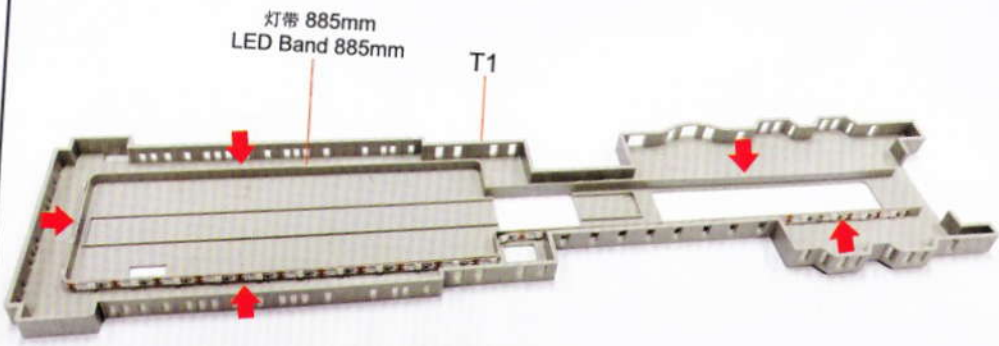

24 如图位置焊接插座线
Weld Socket wires on the light belt as shown in the figure

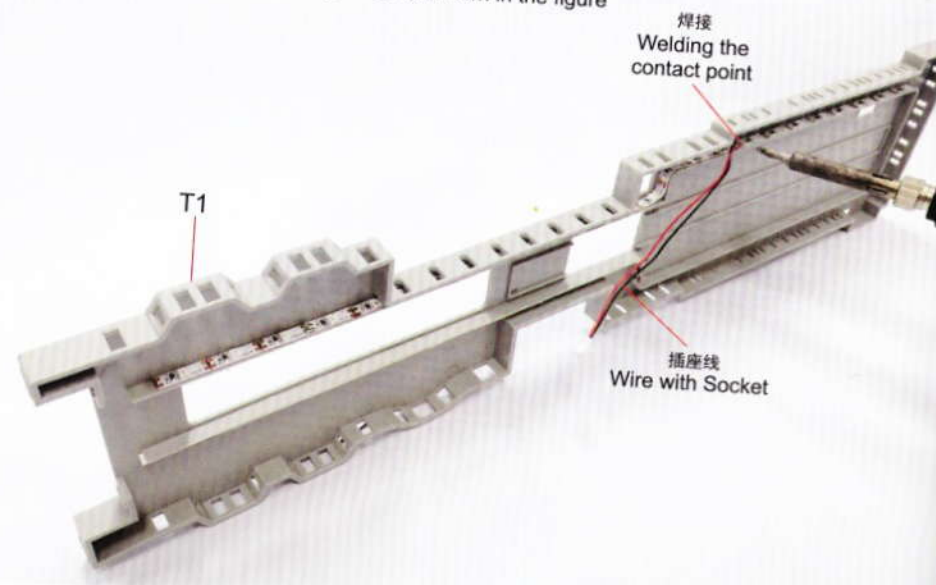

25 如图位置焊接插头线、插座线
Weld the Plug wire and Socket wires
on the light belt as shown in the figure

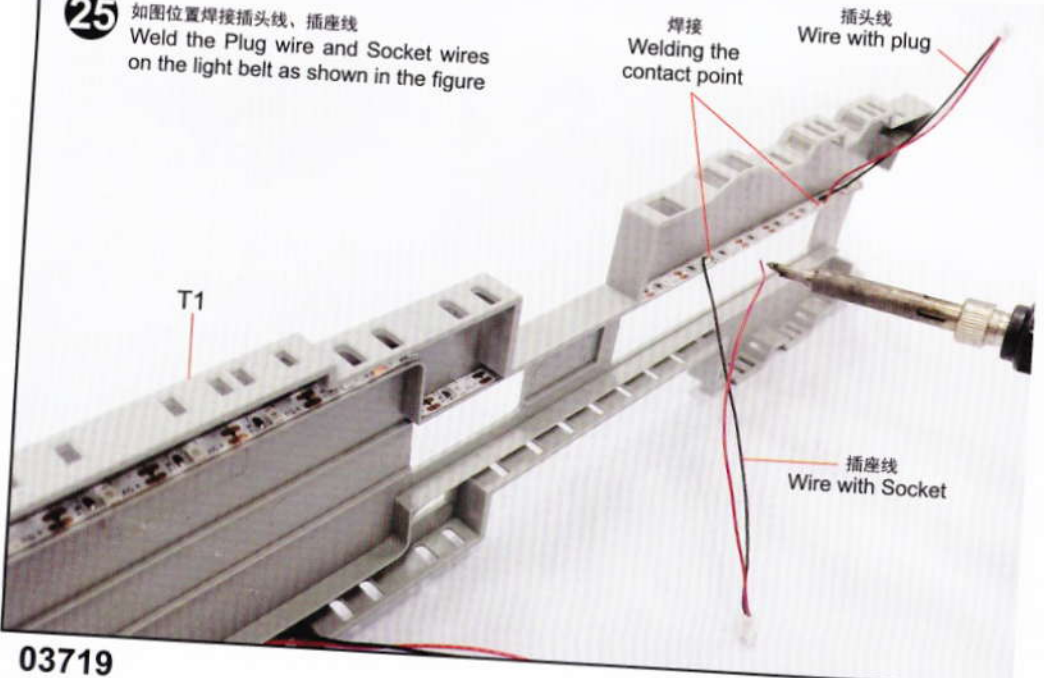

26 打胶固定所有焊接点
Glue and fix all welding points

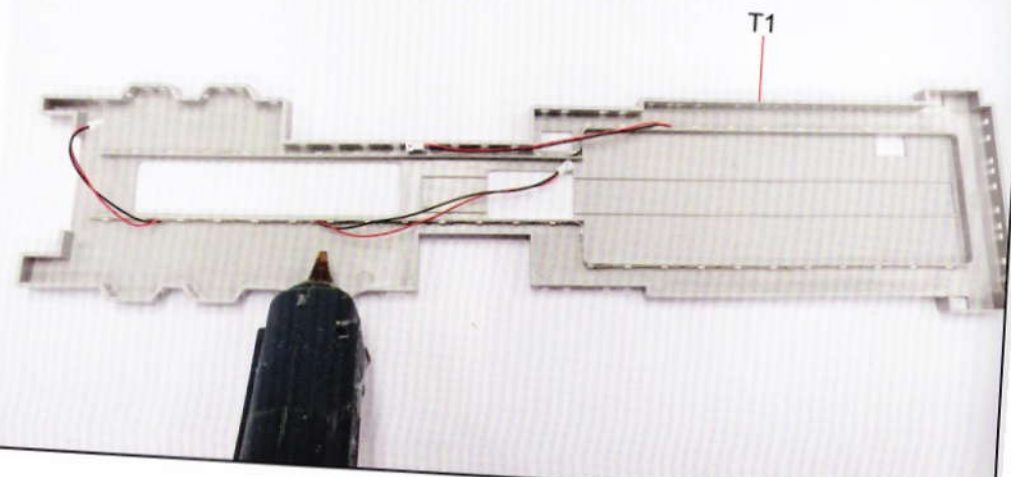

27 U1零件筋外侧贴灯带
Attach LED Band on the outside of U1 part rib

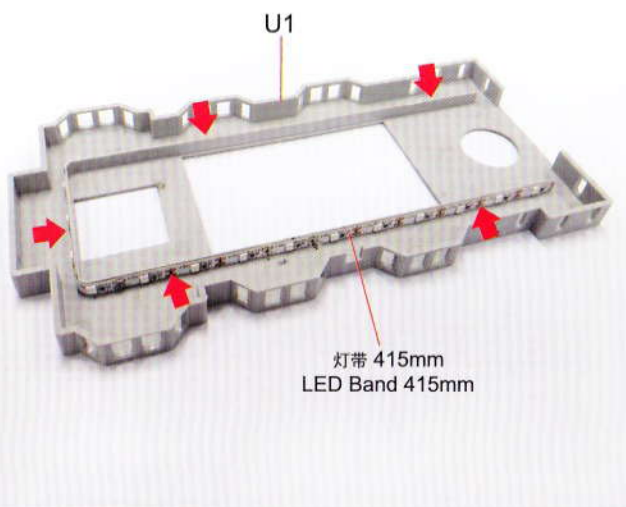

28 U1零件如图位置焊接插座线
U1 Parts as shown in the figure are welded with socket wires on the LED Band

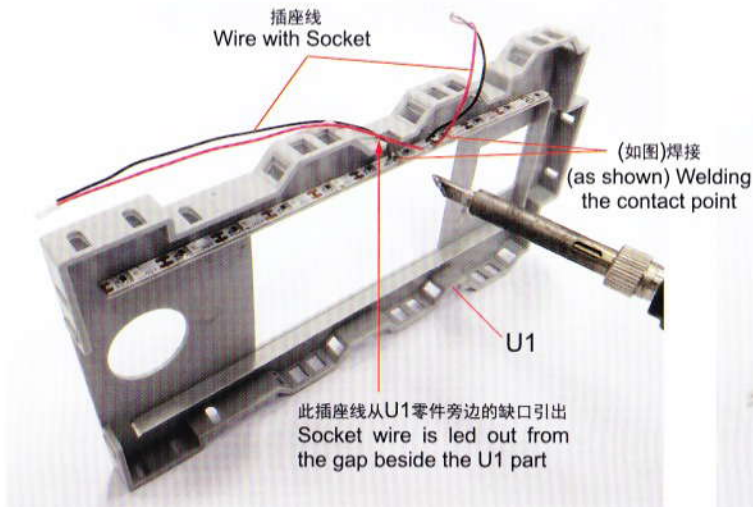

29 U1零件如图位置焊接插头线
U1 Parts as shown in the figure are welded with plug wire on the LED Band

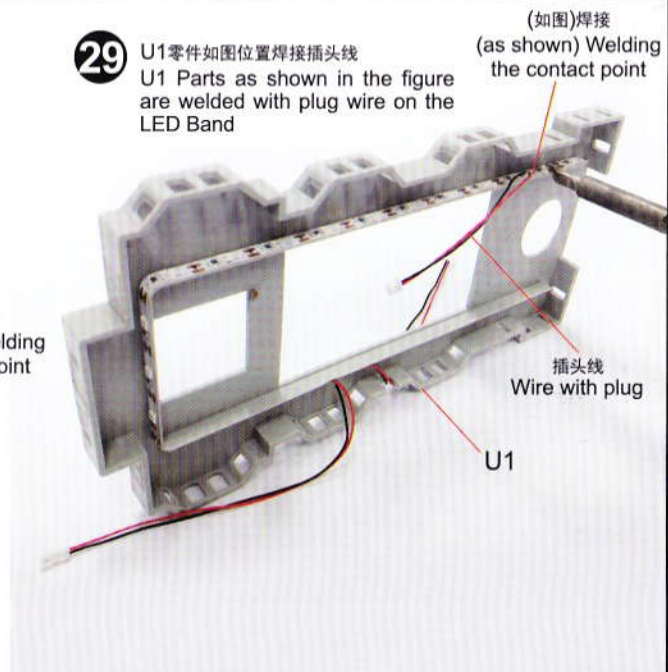

30 打胶固定所有焊接点
Glue and fix all welding points

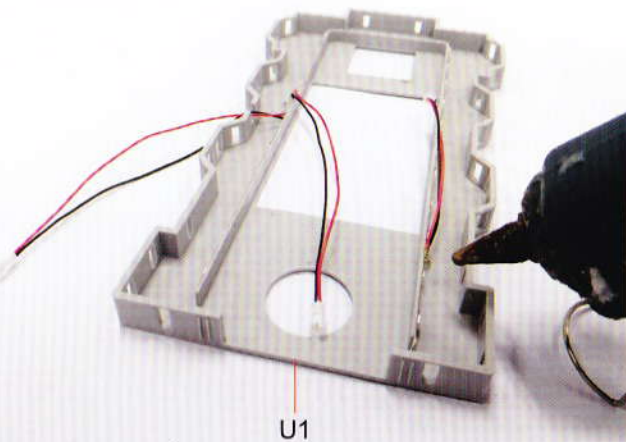

31 T1零件的两条插座线如图穿过T1零件穿孔
Two Socket wires of T1 part as shown in the figure are perforated through T1 part

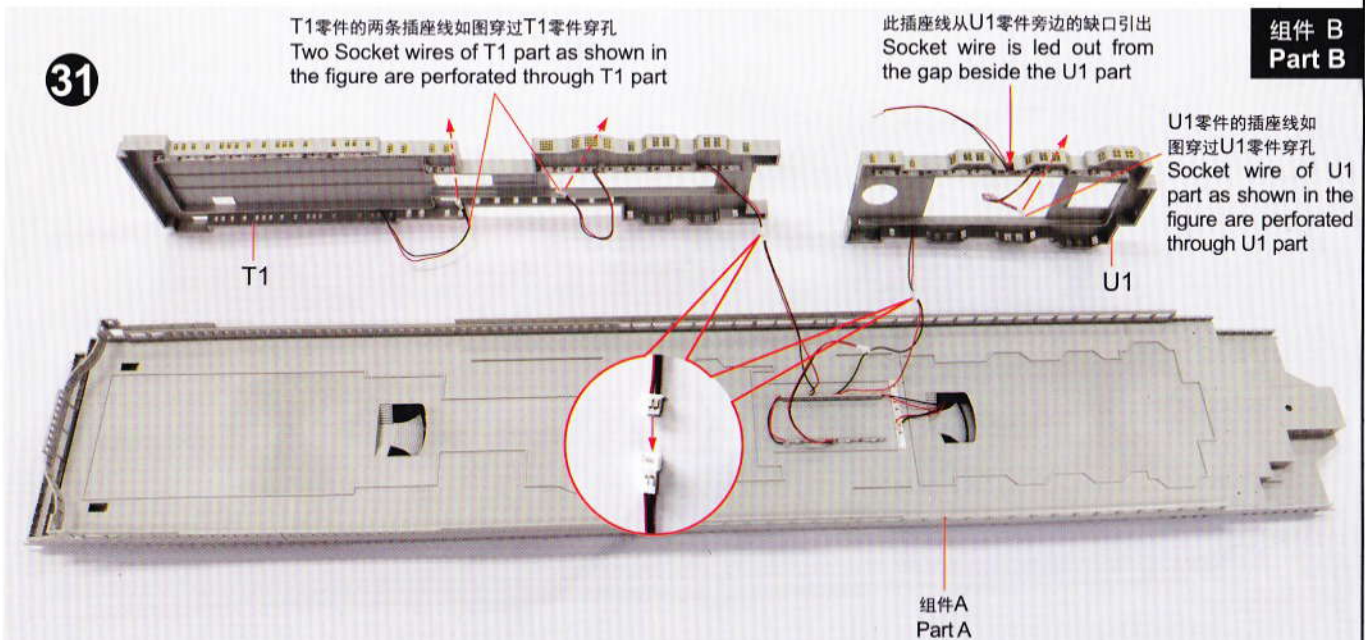

32 钻孔
Drill holes

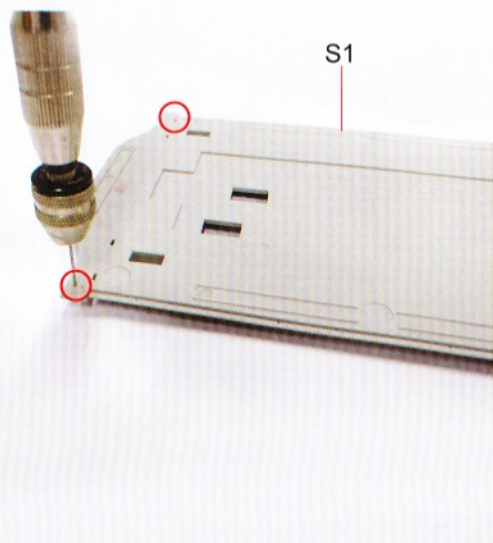

33 贴灯带
Paste LED Band

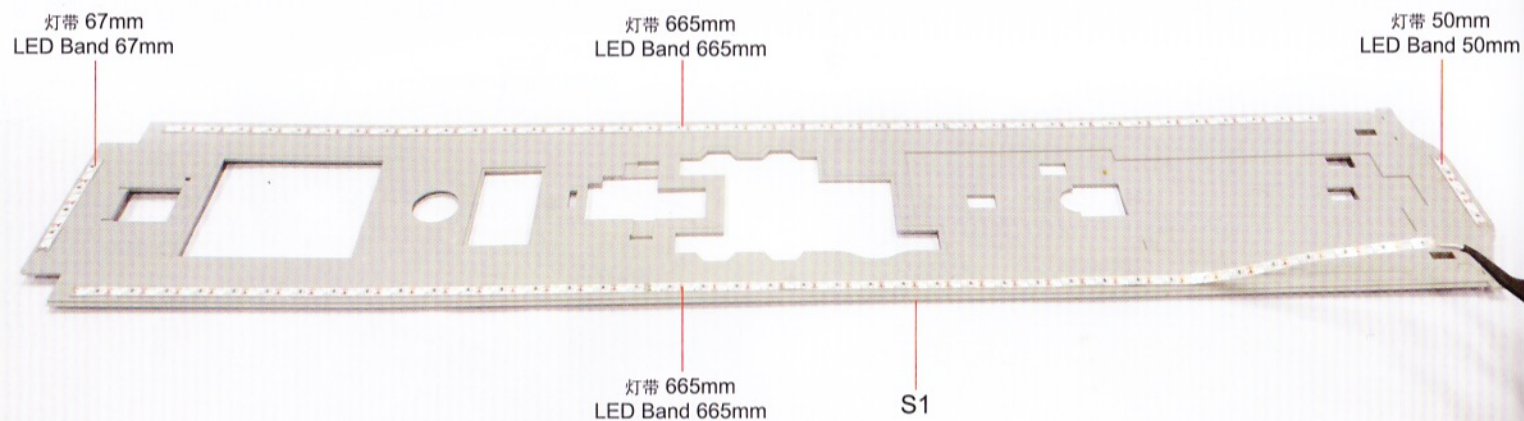

34
LED-绿(无边)
Green LED (Borderless)

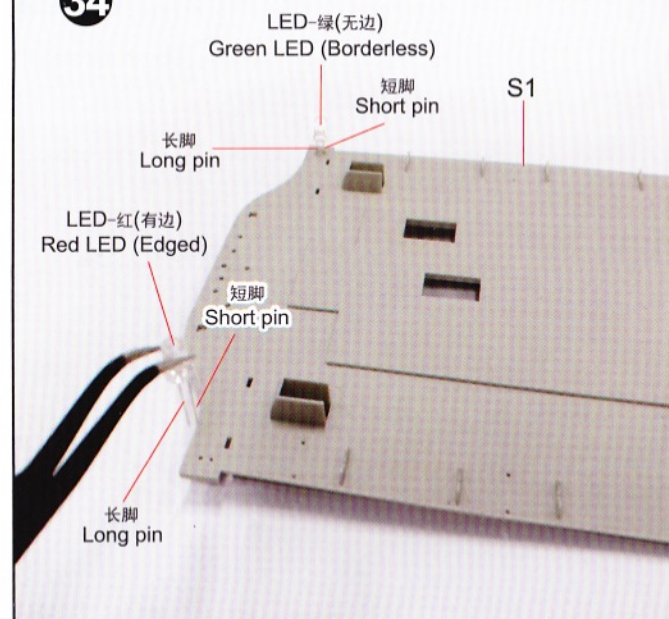

35
黑线 (35mm)
Black Wire (35mm)

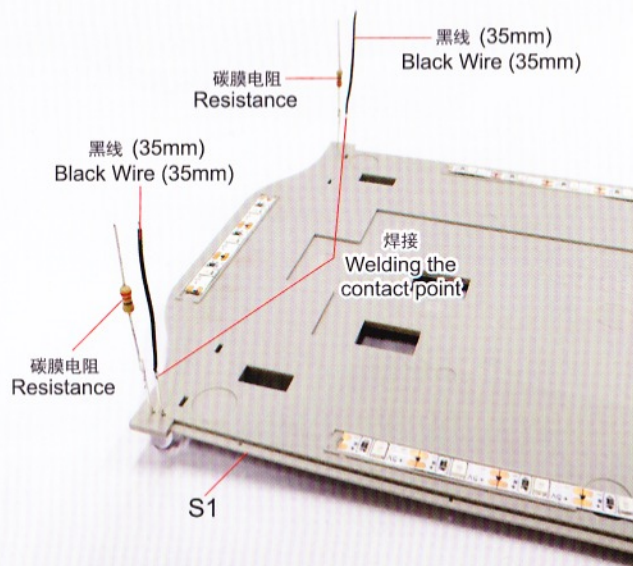

36

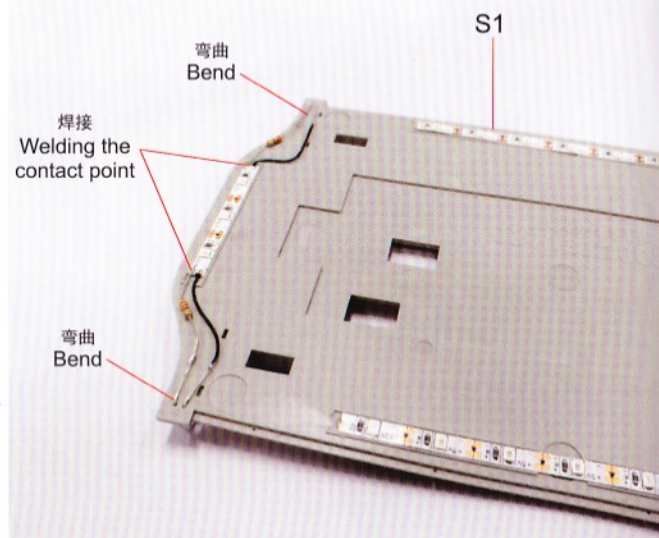

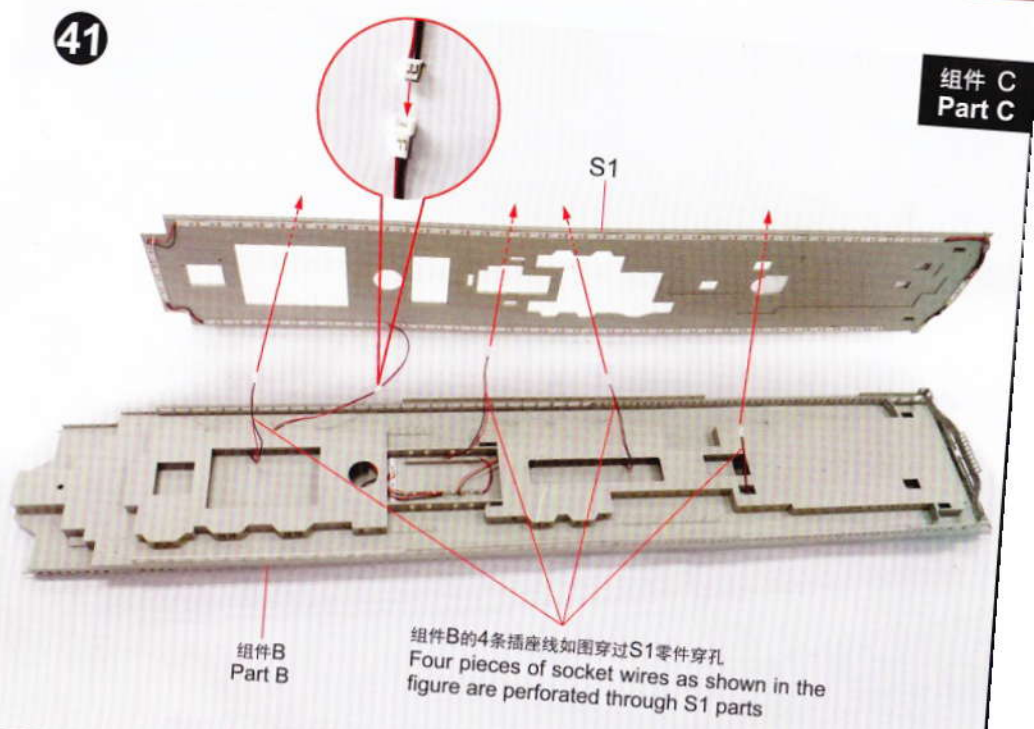
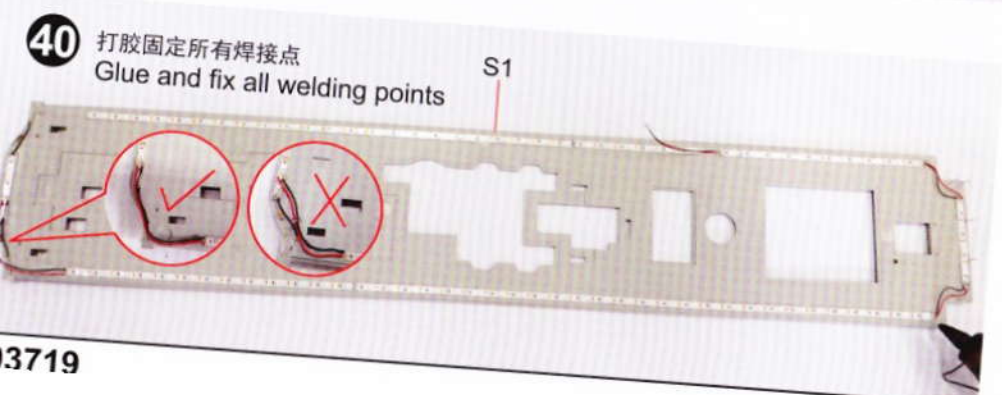
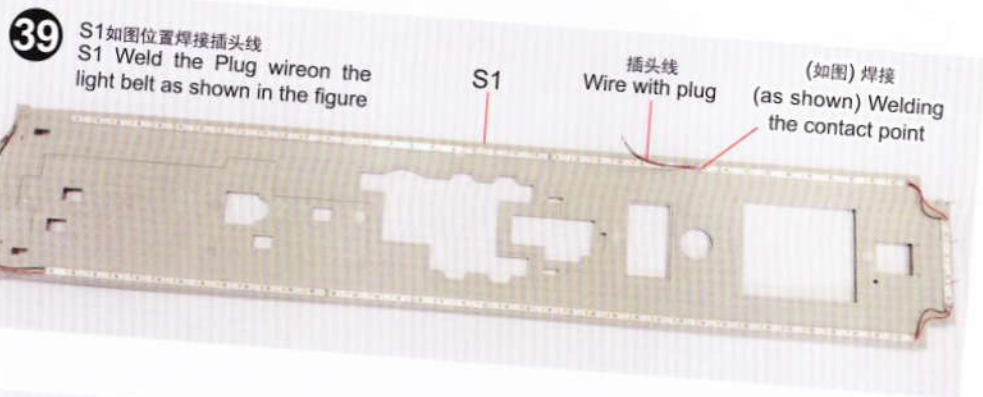
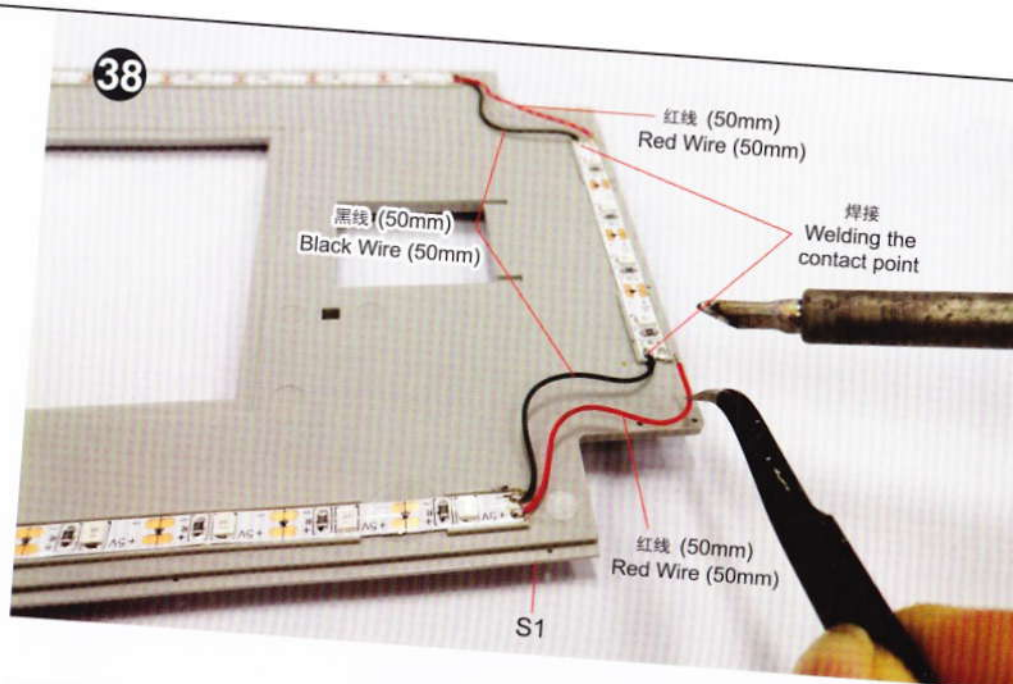
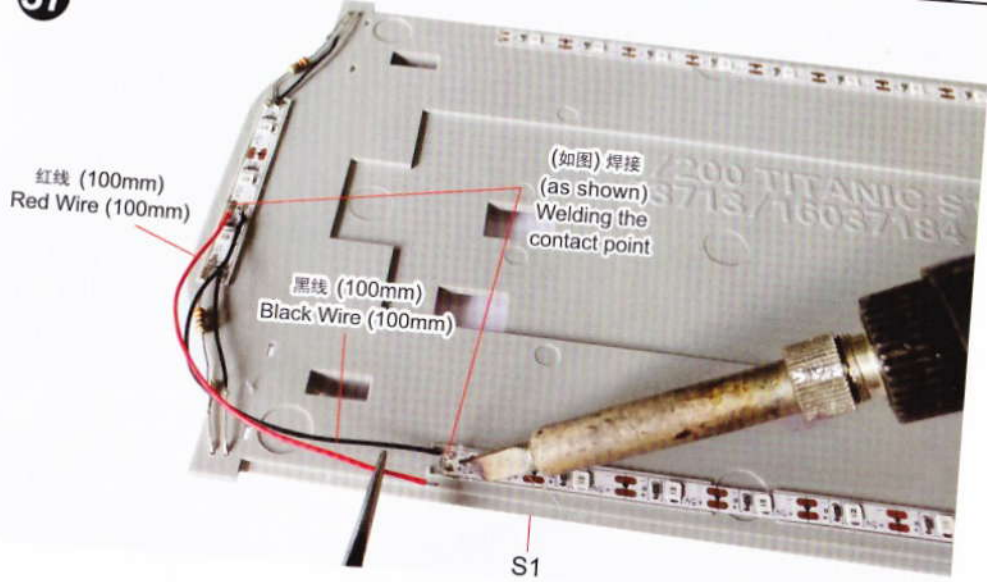

42 钻孔
Drill holes

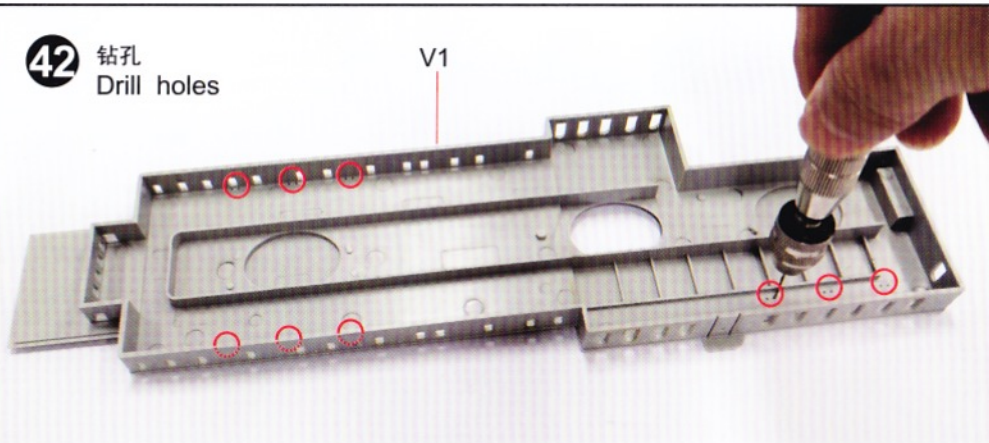

43 钻孔
Drill holes

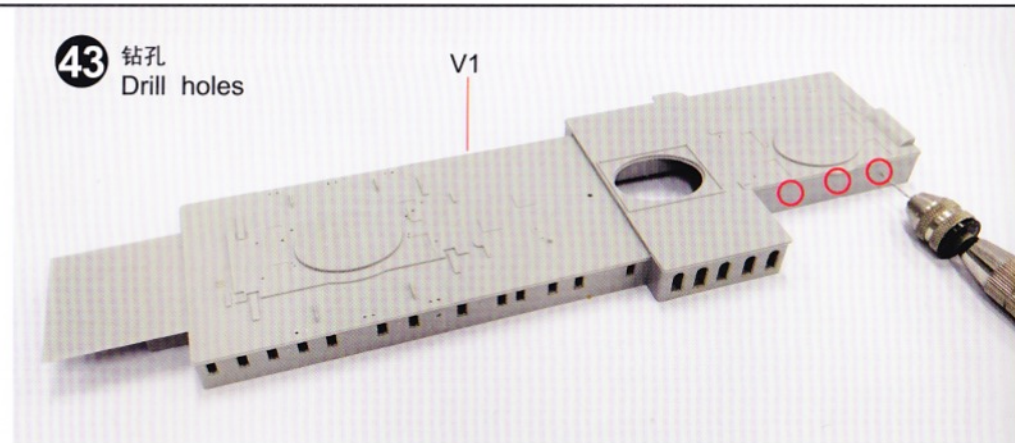

44 V1零件筋位外侧贴灯带
Attach LED Band on the outside of V1 part rib

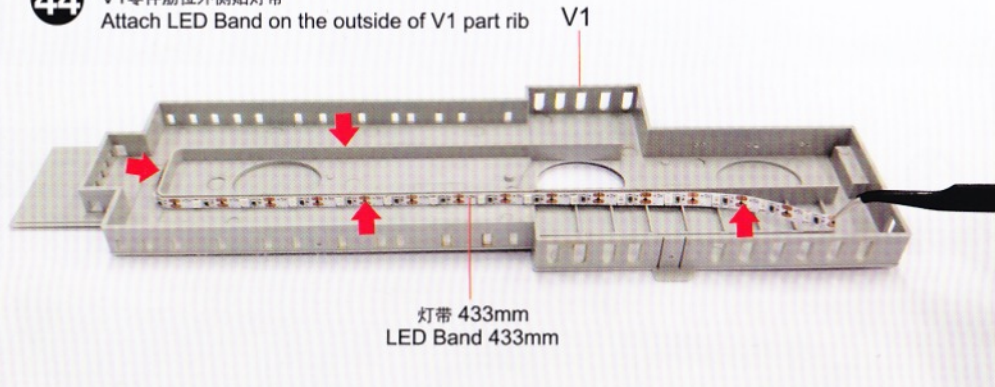

45 如图插LED灯
Insert LED lights as shown

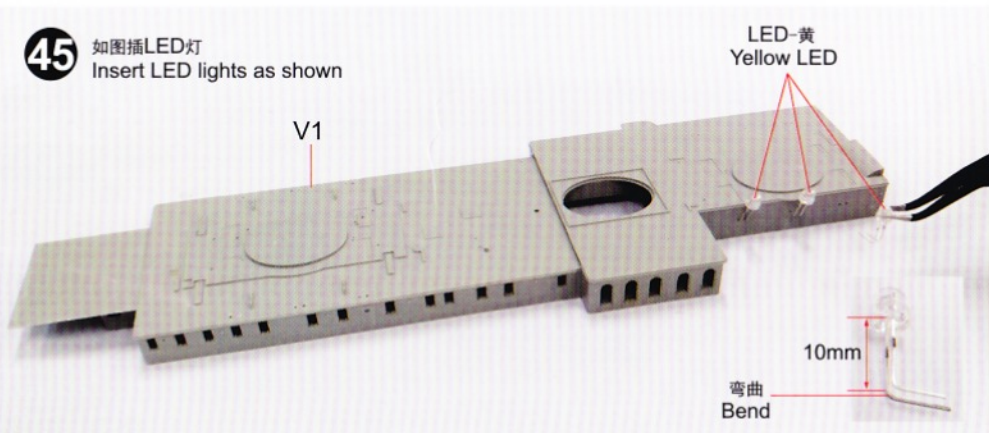

46 如图插LED灯
Insert LED lights as shown

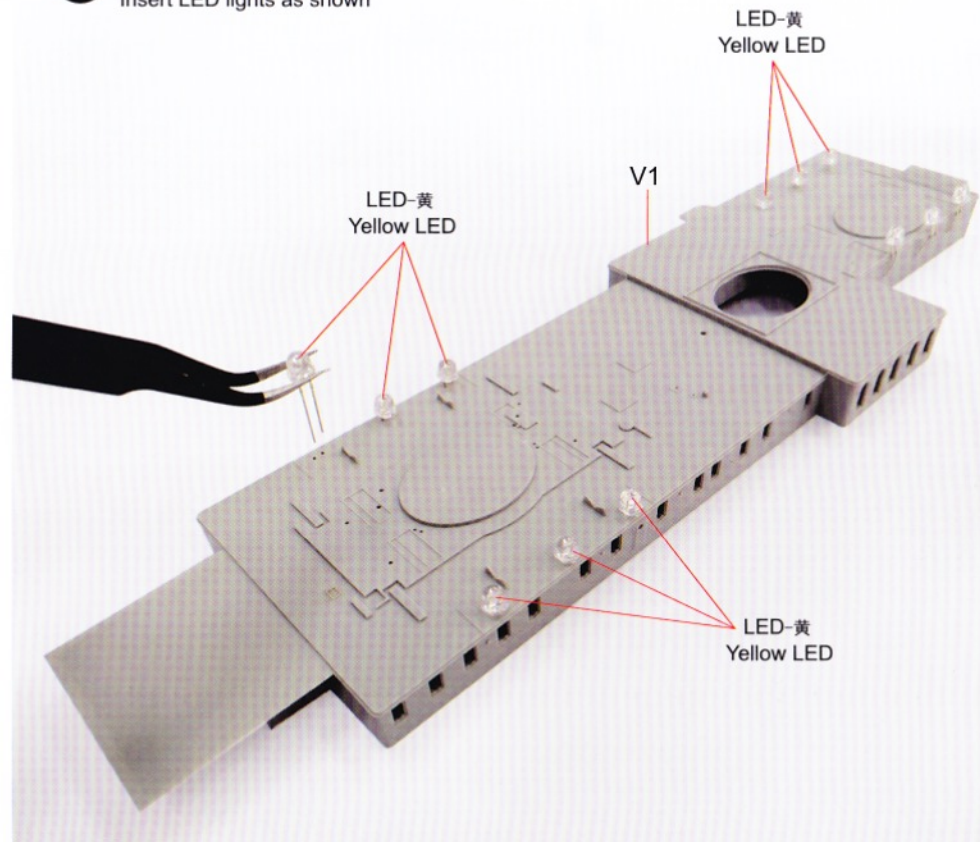

47

黑线 (70mm)
Black Wire (70mm)

焊接 (LED短脚)
Welding the contact point (LED Short leg)

就近焊接
Welding the contact point (nearby)

V1



48

碳膜电阻
Resistance

焊接 (LED长脚)
Welding the contact point (LED Long pin)

V1

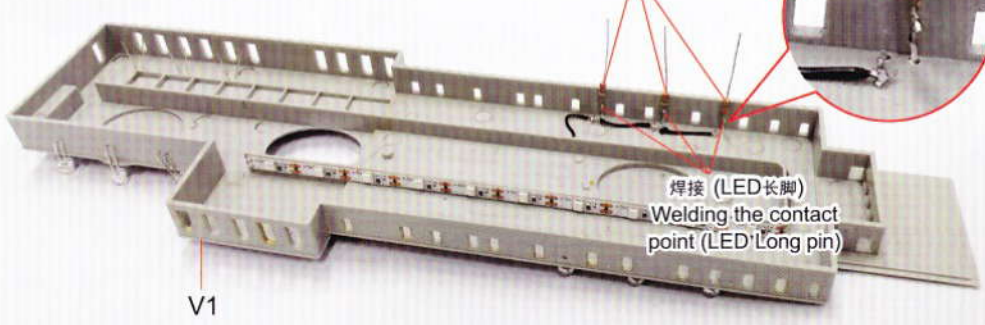

49

弯曲
Bend

就近焊接
Welding the contact point (nearby)

V1

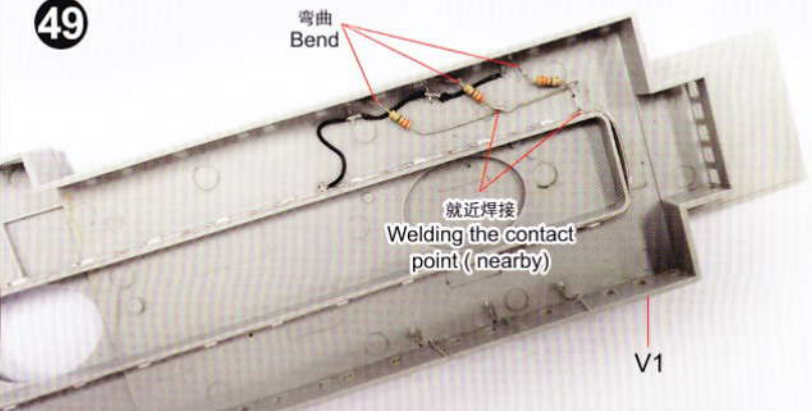

50

焊接 (LED短脚)
Welding the contact point (LED Short leg)

黑线 (70mm)
Black Wire (70mm)

就近焊接
Welding the contact point (nearby)

V1

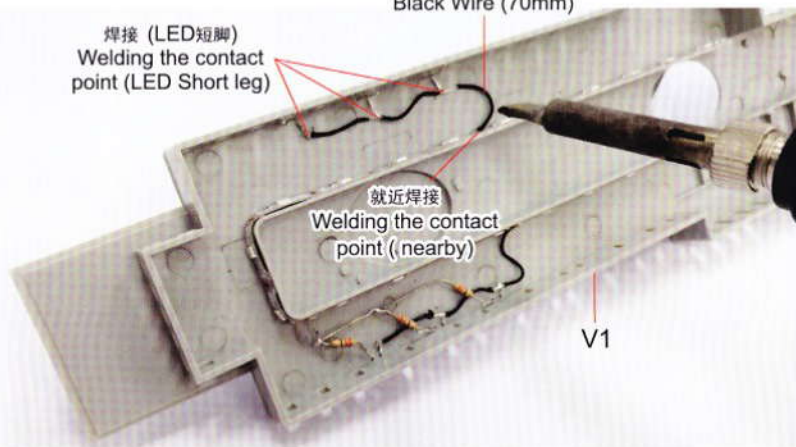

51

碳膜电阻
Resistance

焊接 (LED长脚)
Welding the contact point (LED Long pin)

V1

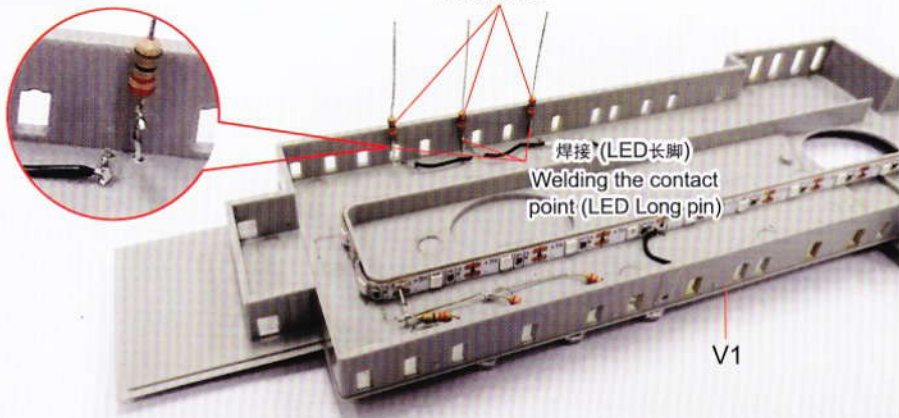

52

弯曲
Bend

就近焊接
Welding the contact point (nearby)

V1

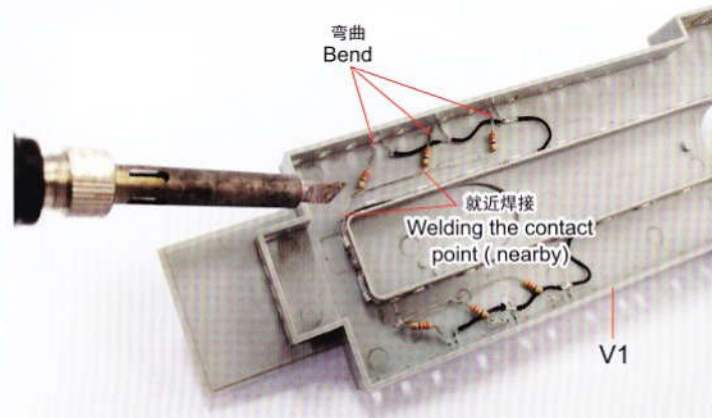

53

焊接 (LED短脚)
Welding the contact point (LED Short leg)

黑线 (145mm)
Black Wire (145mm)

就近焊接
Welding the contact point (nearby)

焊接 (LED短脚)
Welding the contact point (LED Short leg)

V1

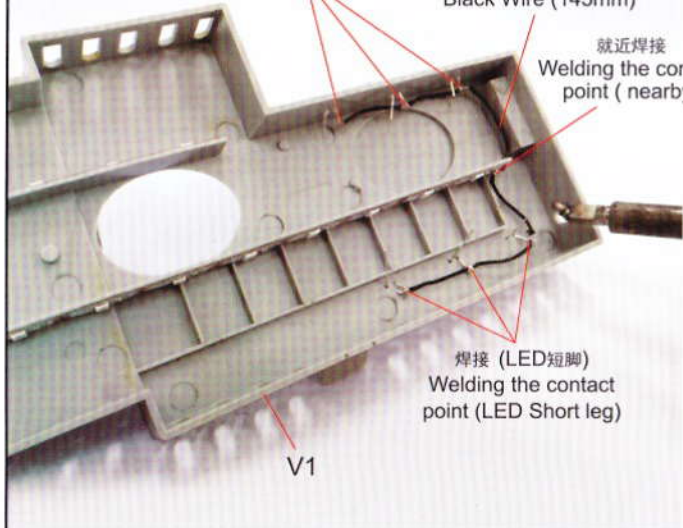

54

对侧相同
Both sides
碳膜电阻
Resistance

焊接 (LED长脚)
Welding the contact point (LED Long pin)

V1

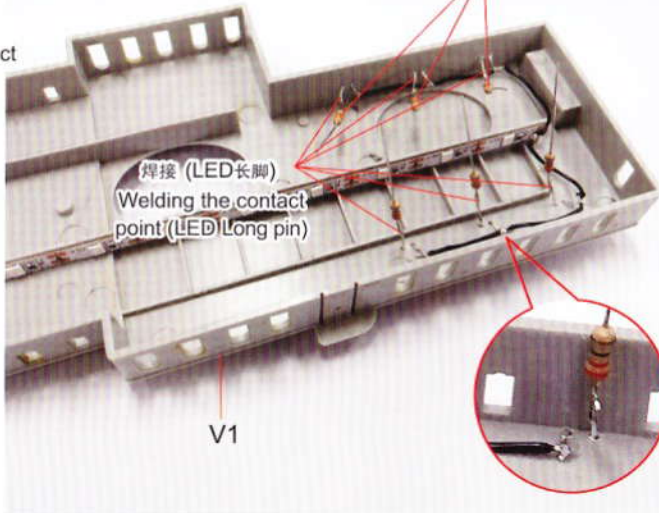

55

对侧相同
Both sides
弯曲
Bend

就近焊接
Welding the contact point (nearby)

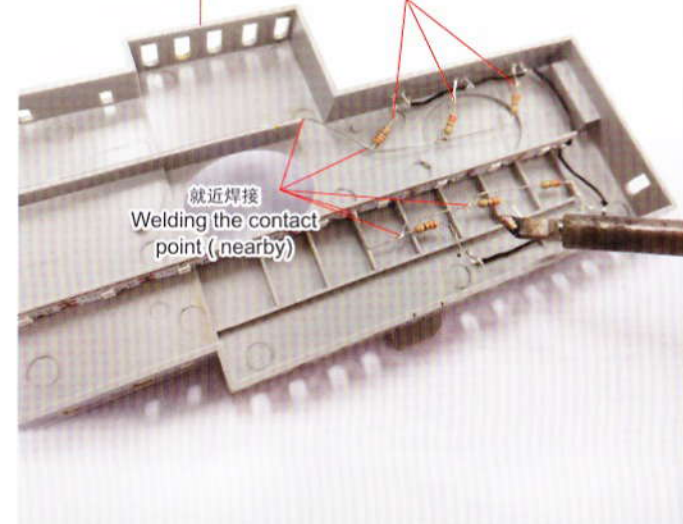

56

(如图) 焊接
(as shown)
Welding the contact point

插头线
Wire with plug

V1

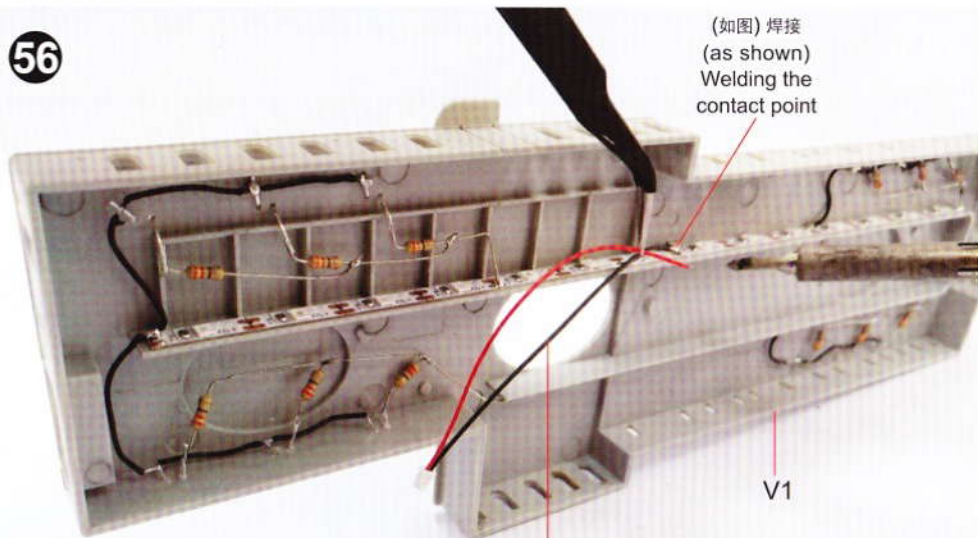

57

打胶固定所有焊接点
Glue and fix all welding points

V1

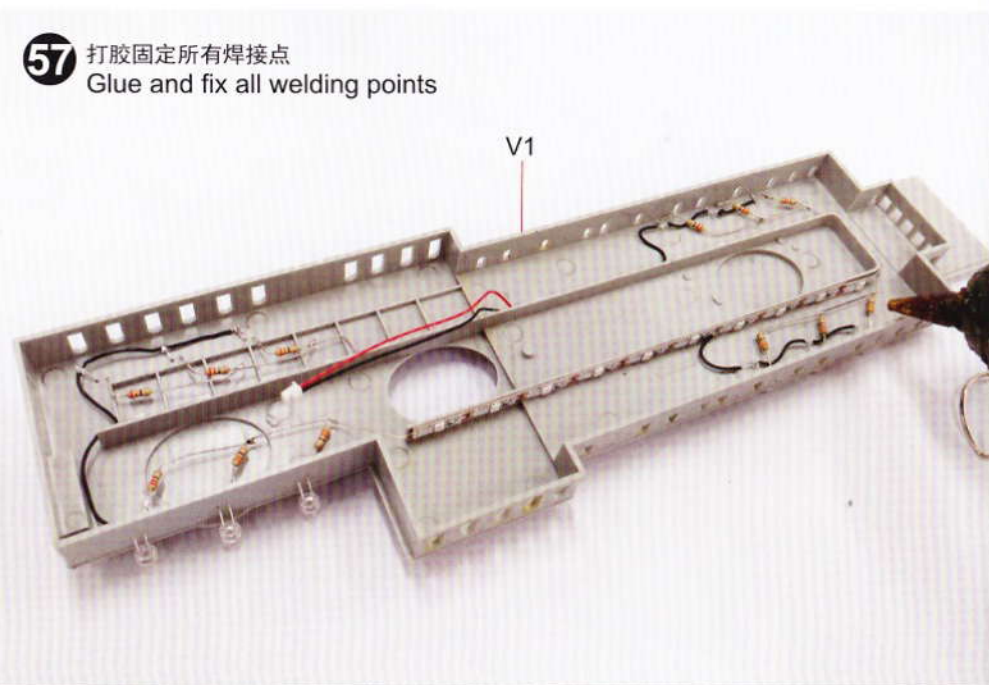

58 贴灯带
Paste LED Band

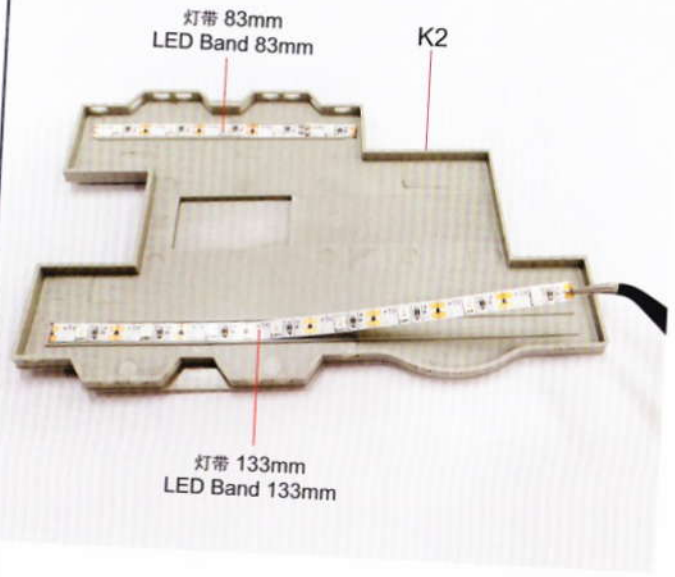

59

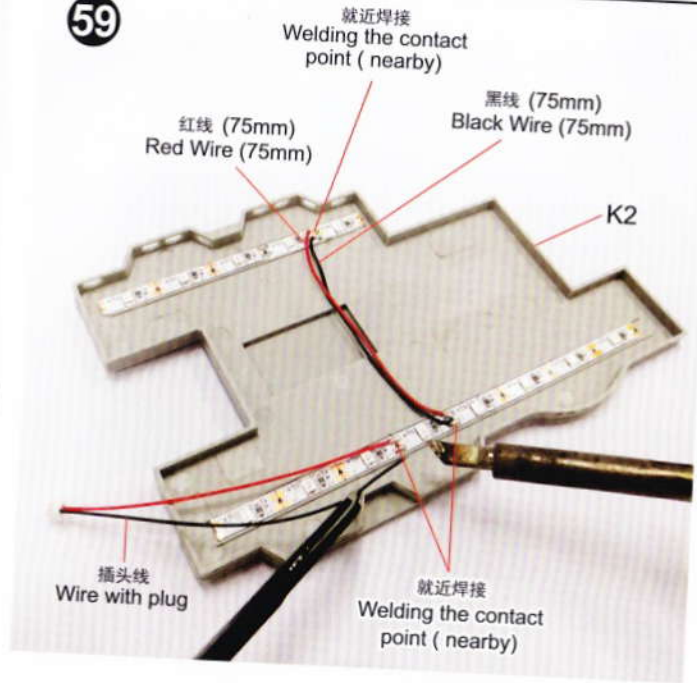

60 打胶固定所有焊接点
Glue and fix all welding points

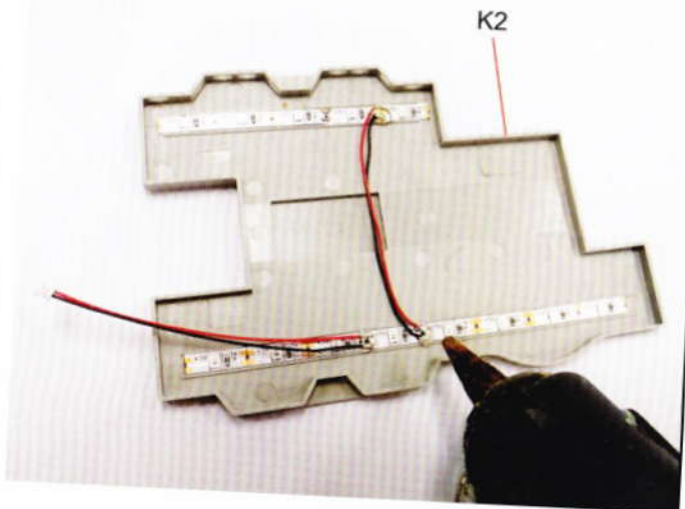

61 钻孔
Drill holes

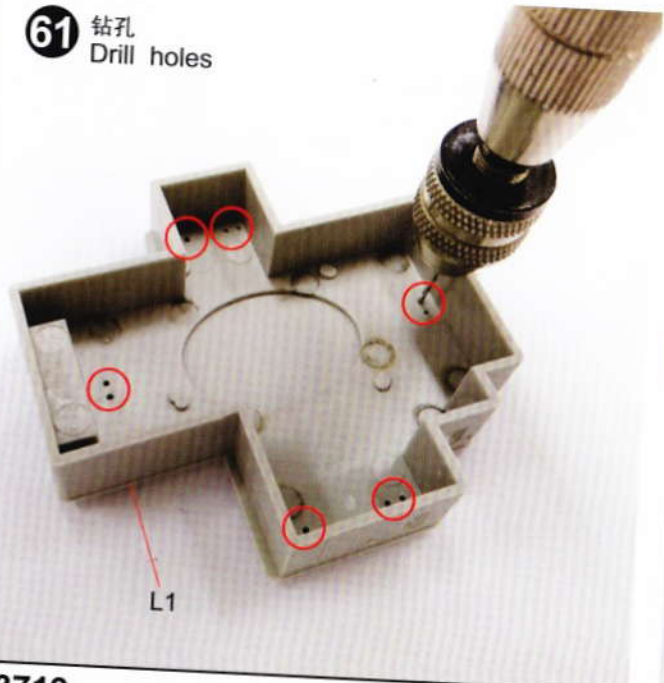

62 如图插LED灯
Insert LED lights as shown

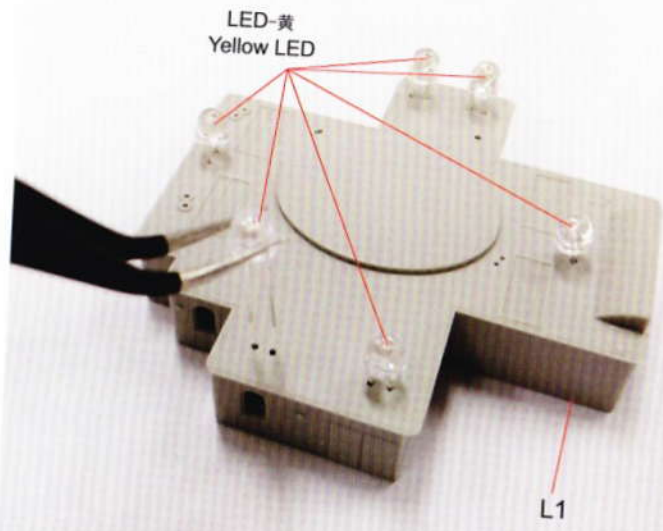

63

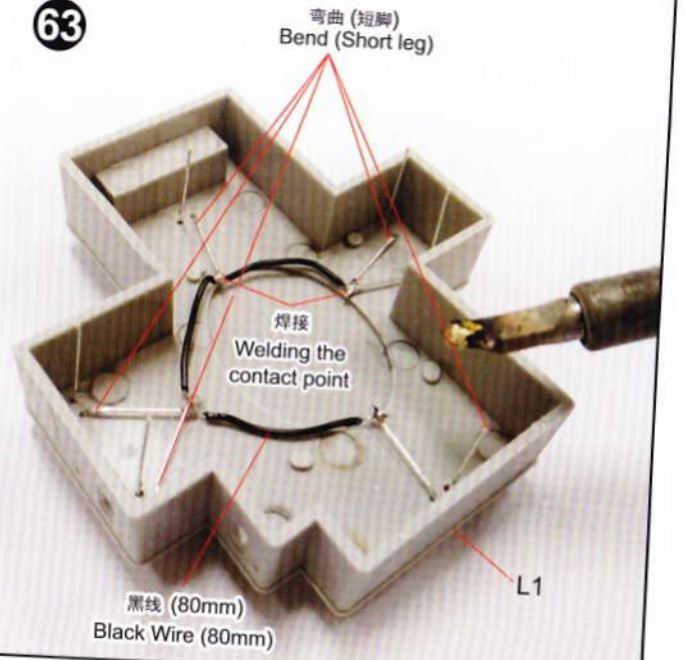

64

碳膜电阻
Resistance

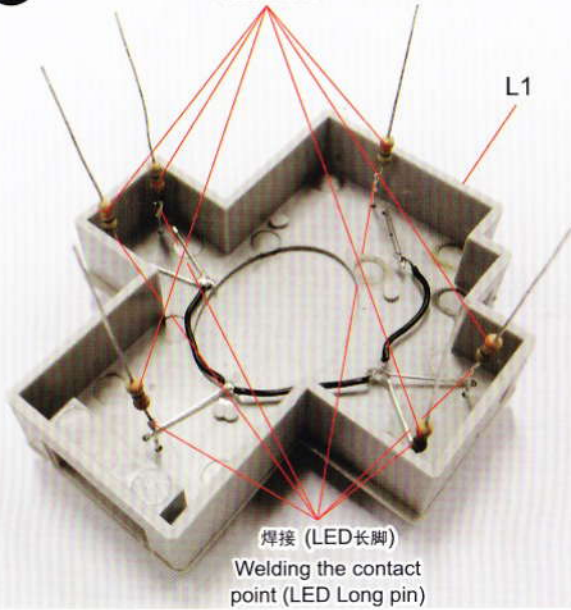

65

弯曲
Bend

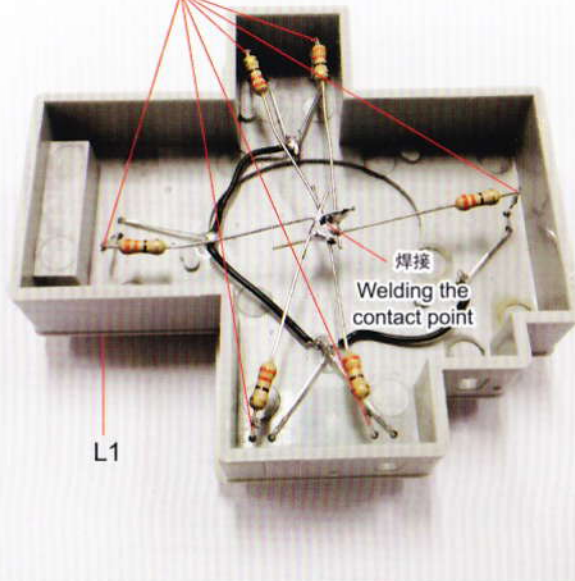

66

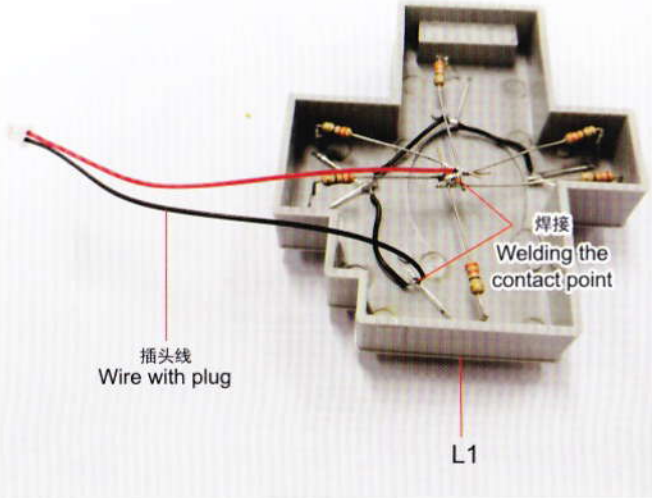

67

打胶固定所有焊接点
Glue and fix all welding points

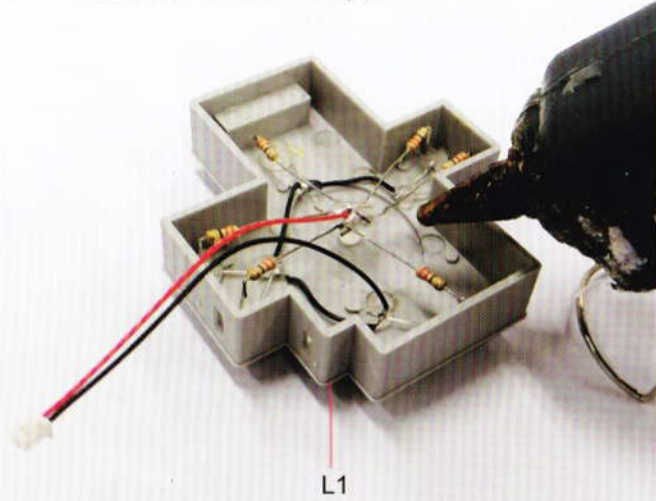

68

钻孔
Drill holes

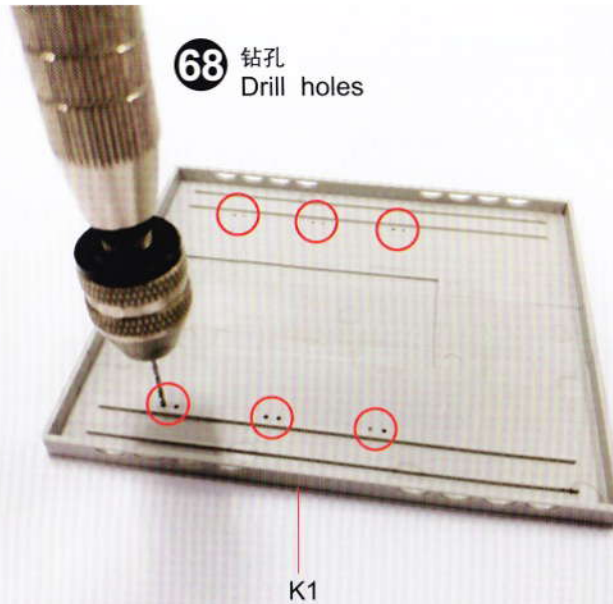

69

贴灯带
Paste LED Band

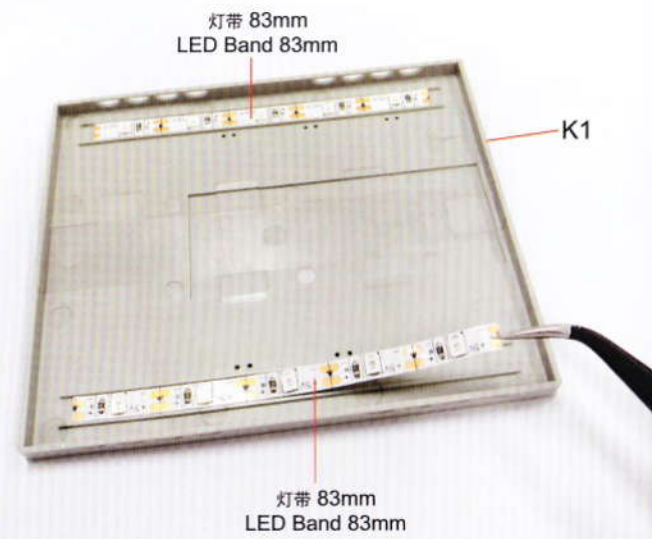

70 如图插LED灯
Insert LED lights as shown

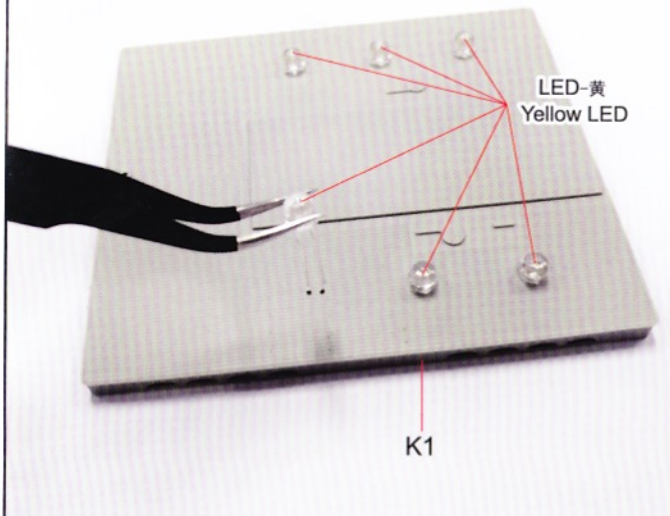

71 就近焊接
Welding the contact point (nearby)

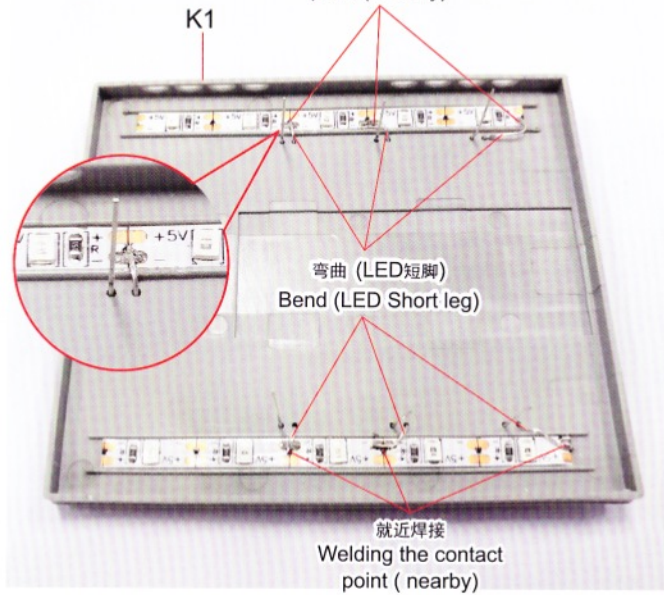

72 碳膜电阻
Resistance

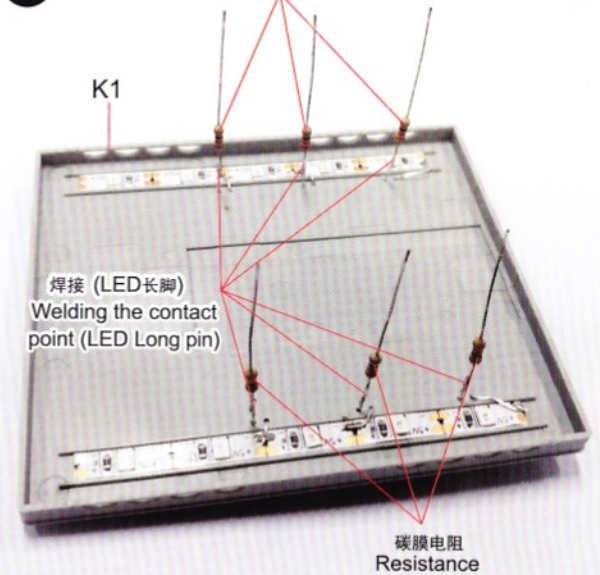

73

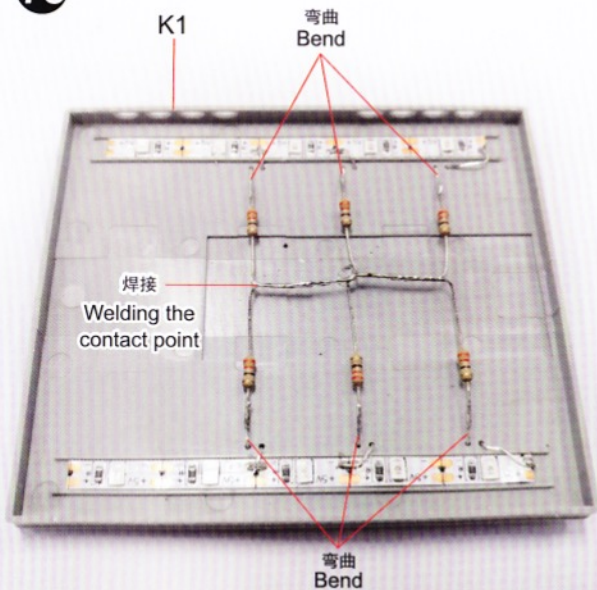

74

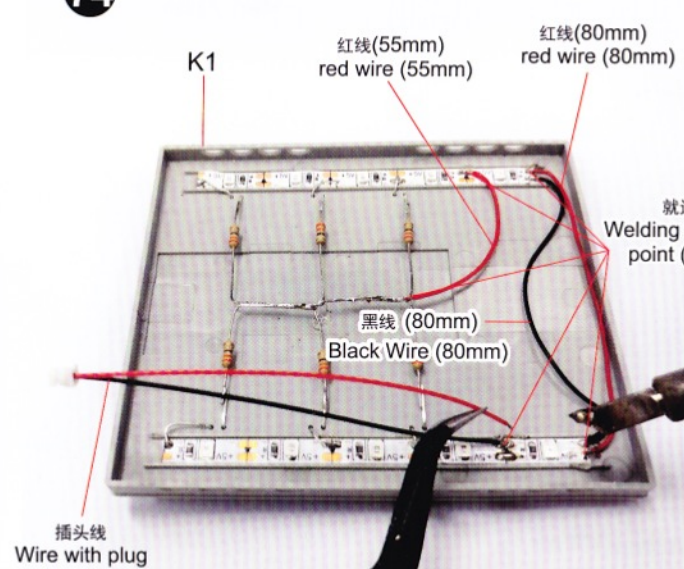

75 打胶固定所有焊接点
Glue and fix all welding points

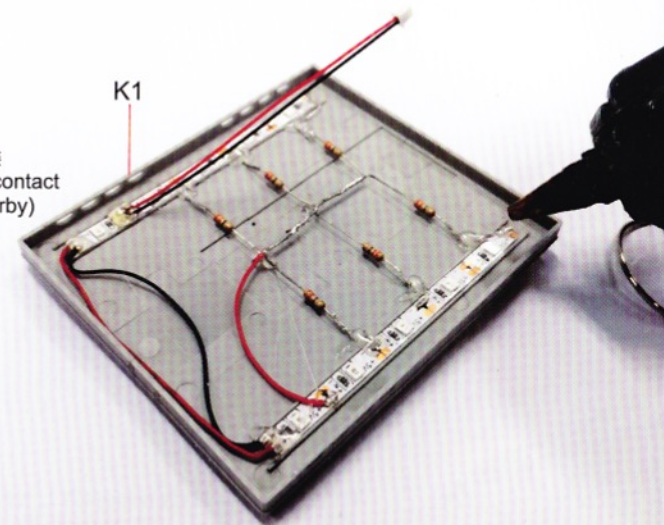

76

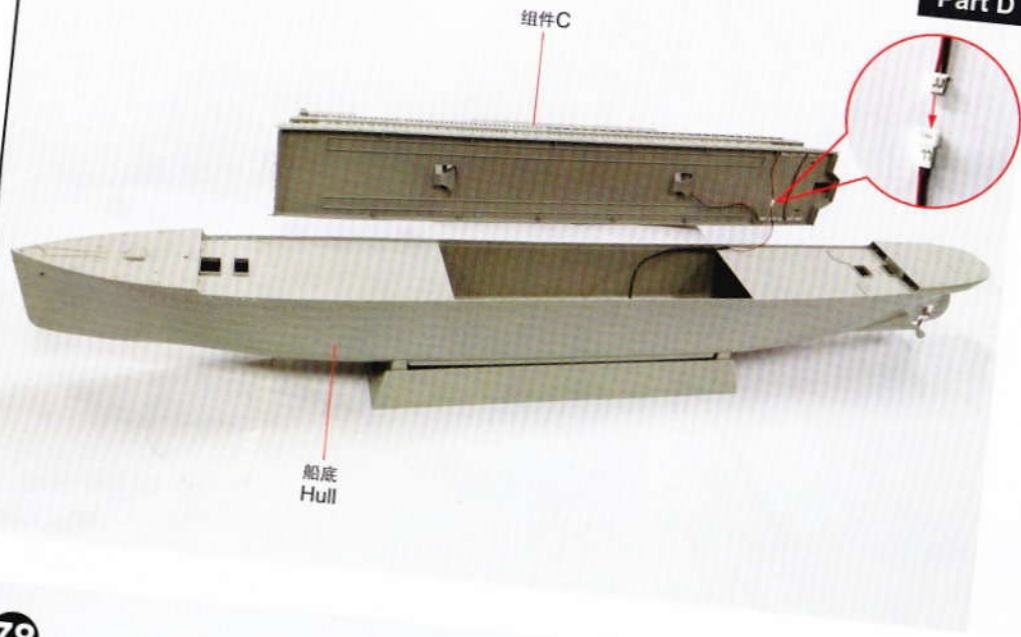

组件 D
Part D

77

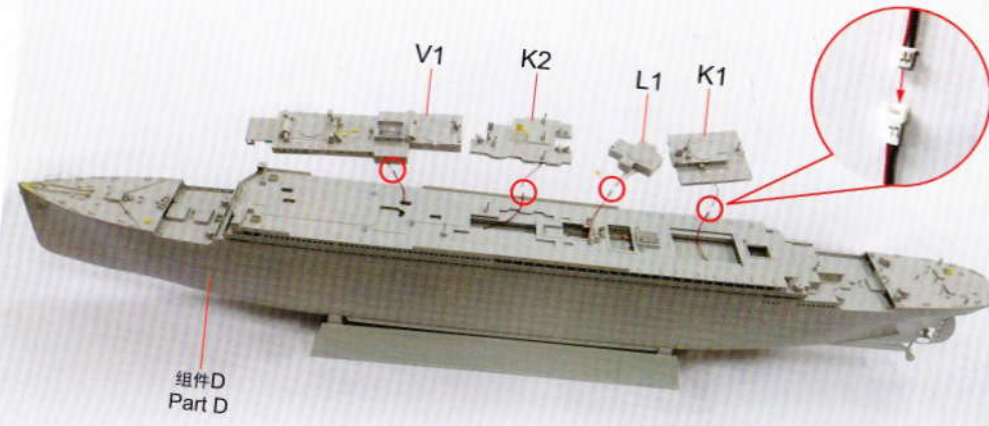

78

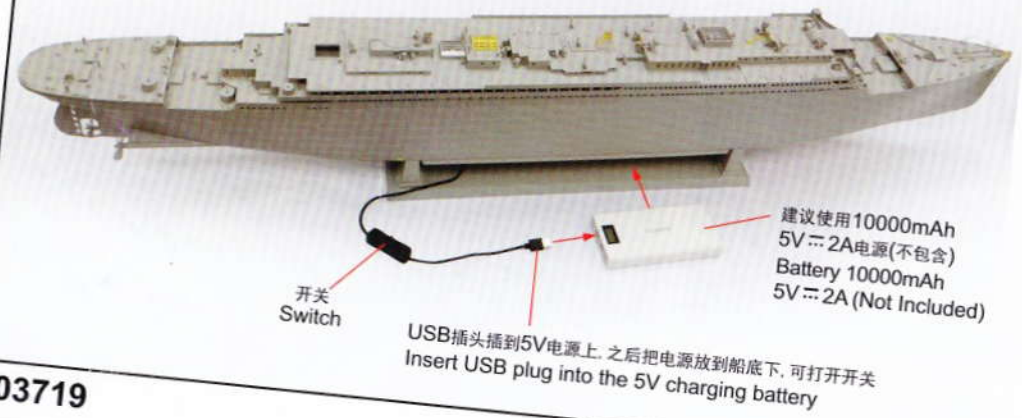

79 完成
Finish

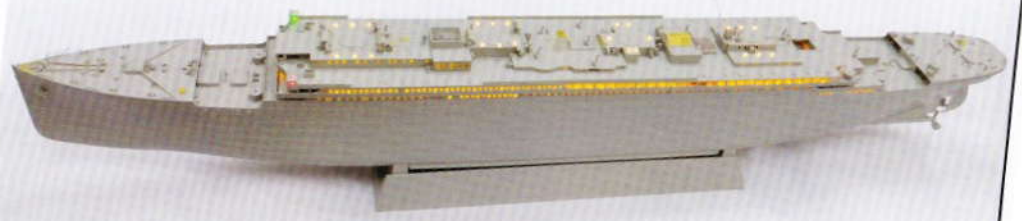

03719

1/200 scale 03719

The Queen of the Ocean

TITANIC



100% NEW TOOLING!

W/LED

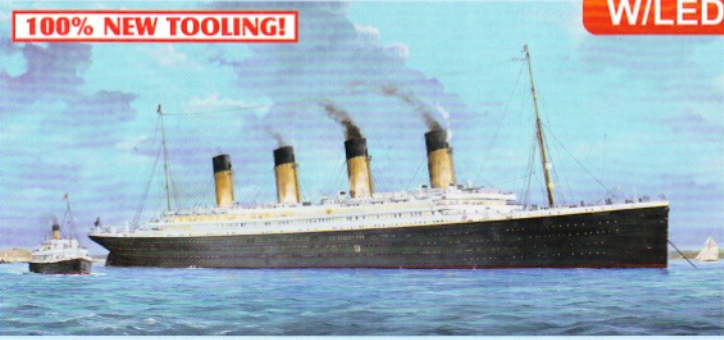

The RMS Titanic was built in Belfast, Northern Ireland, by the shipyard Messrs. Harland & Wolff. Construction of the Titanic began March 31st, 1909, with the laying of her keel, and would continue up until her maiden voyage. At the time of her maiden voyage, the Titanic was the world's largest ocean liner. She was built with many safety features and was claimed to be unsinkable. On the afternoon of April 10th, 1912, the Titanic departed Southampton, England, on her maiden voyage and headed to Cherbourg, France, followed by Queenstown, Ireland, before beginning her crossing of the North Atlantic Ocean towards her intended destination of New York in the United States. On the clear moonless night of April 14th, at 11:40 p.m., the Titanic struck an iceberg and began sinking by the head. By 2:00 a.m. most of the Titanic's lifeboats were gone but many people were left on board the doomed ship. As the Titanic's final moments approached, her bow plunged below the icy waters of the Atlantic, her stern rose out of the water, and the unsinkable ship broke in two. In the early morning hours of April 15th, 1912, nearly 2 hours and 40 minutes after the collision with the iceberg, the Titanic disappeared below the surface of the Atlantic Ocean. Her wreck remained lost until 1 September 1985 when her twisted and broken hull was discovered 12,480 feet down. The Titanic carried 2208 passengers and crew that fateful night and claimed the lives of 1496 people when she sank. The Titanic became one of the worst maritime disasters in history and has become one of the most famous shipwrecks.

The kit consists of 656 parts on 35 sprue, 649 parts photo-etched and metal chain.

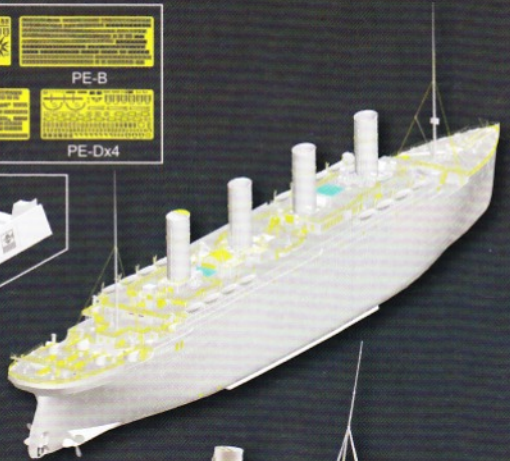
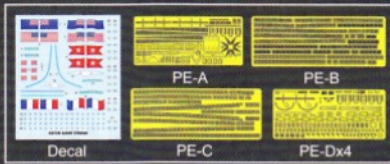

Bow and stern masts with crow's nest and photo-etched ladders.

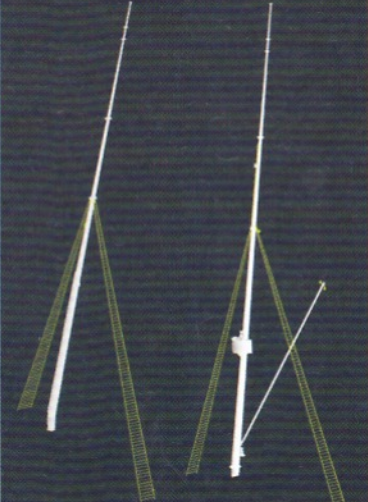

Funnels detailed with photo-etched ladders.

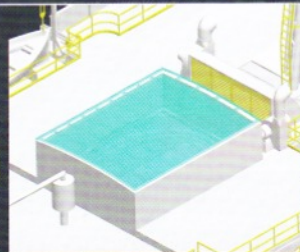
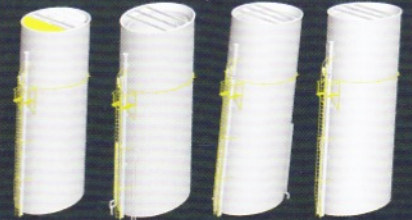

Cranes with photo-etched details.

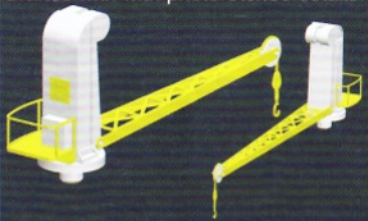

Multiple photo-etched ship details.



Separately molded anchor chain pulleys.

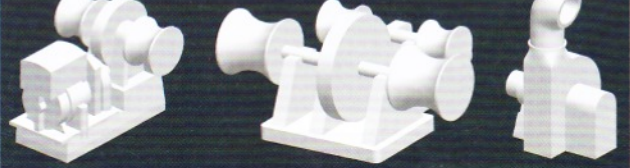

Separately molded lifeboats with davits and photo-etched pulleys.



Trumpeter_Hobbyboss

Trumpeter_Hobbyboss

trumpeter&hobbyboss fan club

小号手模型