

HONDA PRELUDE XX



1/24 SPORTS CAR SERIES



In 1962, the famous Honda motorcycle company ventured into the field of automobile manufacturing with the release of a Sport 360 car and a small T360 truck, then surprised the industry with the release in October of next year with their true sports car, the S500. This two seater had a 4 cylinder DOHC 531cc engine which put out 47hp and really attracted the attention of the sport car world. They added the S600 in 1964 and S800 in 1965 which carried larger engines. With Honda's entry into Formula 1 racing, the experience gained with this high performance engine competition added considerable credibility to this already respected firm. When they released the high performance 1300 street car in 1969, it was a big success and established Honda as a viable manufacturer of high quality vehicles that could compete with the then booming Japanese car market. The first Honda Prelude was released in November 1978. It was a sporty model with front wheel drive; however emphasis was placed on comfort and driving ease, rather than all out performance. It was very easy to handle in traffic and the engine power was more than enough to satisfy it's admirers. In 1982, the Prelude received a complete model change, being offered in three types. The notched back coupe was of similar style to the first Prelude, and the top ranked model is called the XX. The greatest features of this new series is in the chassis components, as the latest in the state of the art are employed. Four wheel independent suspension, with a double wishbone in front. Stability is enhanced by a tread of

1470mm, which is quite wide for a 1800cc class car. This suspension system is the same as used on many racing cars, but not seen on production vehicles. Both the XX and XZ models have four wheel disc brakes as standard, and for the first time, a micro computer system is used to check slippage during braking and automatically increases or reduces braking pressure so that the car stops in the shortest possible time without skidding during sudden braking. Each model of the Prelude has the same 4 cylinder 1829cc engine with 3 valves per cylinder. Two intake and one exhaust valve and a compression ratio of 9.4-1. The engine puts out 125hp and the car can accelerate from 0—400m in 17 seconds. The retractable headlights and wedge shaped body styling point it out as a real sport car, and with its revolutionary suspension and power train, this Prelude is sure to be extremely popular with the public for years to come.

* * *

1962 stieg der bekannte Motorradhersteller Honda in das Autogeschäft ein und brachte als Erstes den Sportwagen 360 und den kleinen Lieferwagen T360. Im darauffolgenden Jahr wurde der Sportwagen S500 im Oktober fertig. Dieser Zweisitzer hatte einen 4 Zylindermotor DOHC mit 531cc, brachte 47 PS und zog die Begeisterung der Sportwagen-Fan's auf sich. 1964 kam der S600, 1965 der S800, beide Wagen hatten grössere Motore. Als dann Honda noch in die Formel 1 Klasse einstieg, bewies sich die Zu-

verlässigkeit und Leistung ihrer grossen Motore. Als dann 1969 der grosse 1300er Wagen herauskam, wurde dies der grosse Erfolg von Honda, ein Fahrzeug hoher Qualität welches in dem Autoboom Japans grosse Beachtung fand. Der erste Honda Prelude kam dann im November 1978, ein sportliches Fahrzeug mit Vorderradantrieb, leicht zu fahren und sehr komfortabel. 1982 kam dann der komplette Modellwechsel und das Fahrzeug wurde in 3 Variationen angeboten. Das Coupe mit Stufenheck war dem ersten Prelude ähnlich, das Spitzenmodell wurde XX genannt. Die grössten Änderungen dieser neuen Serie liegt in der Ausführung des Chassis, in das das Neueste eingebaut wurde. Vierrad unabhängige Aushängung, mit doppeltem Federbein vorne, die Spurbreite von 1470mm ist die, der 1800cc Wagen. Das Aushängungssystem ist das gleiche, wie es in vielen Rennwagen eingebaut wird, aber nicht in Produktionswagen. Die Modelle XX und XZ haben 4 Scheibenbremsen und die erste Micro-Computer Anlage, welches das Blockieren der Räder beim Bremsen verhindert. Jedes Modell der Prelude-Serie hat den gleichen Vierzylinder Motor mit 1829cc und 3 Ventilen pro Zylinder. Zwei Einlass- und ein Auslassventil, die Verdichtung liegt bei 9,4-1, der Motor bringt 125 PS und der Wagen beschleunigt von 0 auf 400 m in 17 Sekunden. Die einziehbaren Scheinwerfer und die kantige Karosserie machen den Prelude zum Sportwagen, die Aushängung und die Motorkraft wird den Prelude von Honda auch noch in den nächsten Jahren sehr populär machen.

3 «Attached Engine»
«Eingebauter Motor»

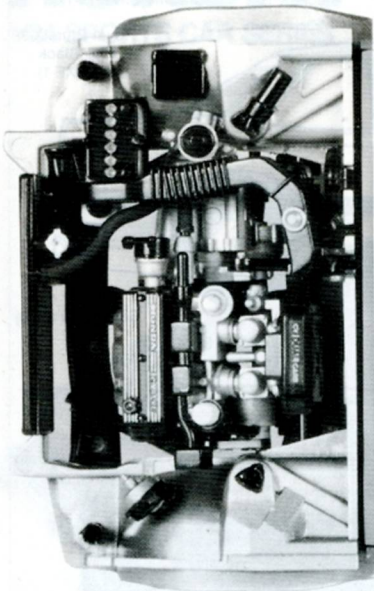

«Knuckle Hubs»
«Lenknaben»
«Right»
«Rechts»

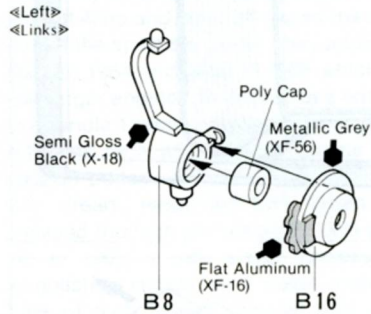
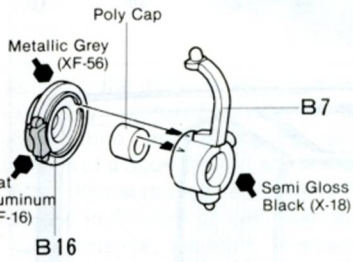

«Attaching Forked Damper»
«Anbringung der Gabel-Stoßdämpfer»

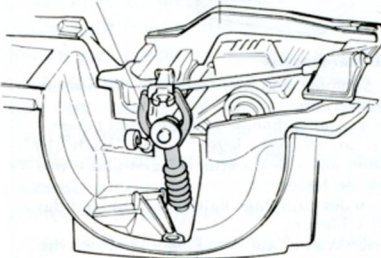

3 Attaching Engine
Einbau des Motors

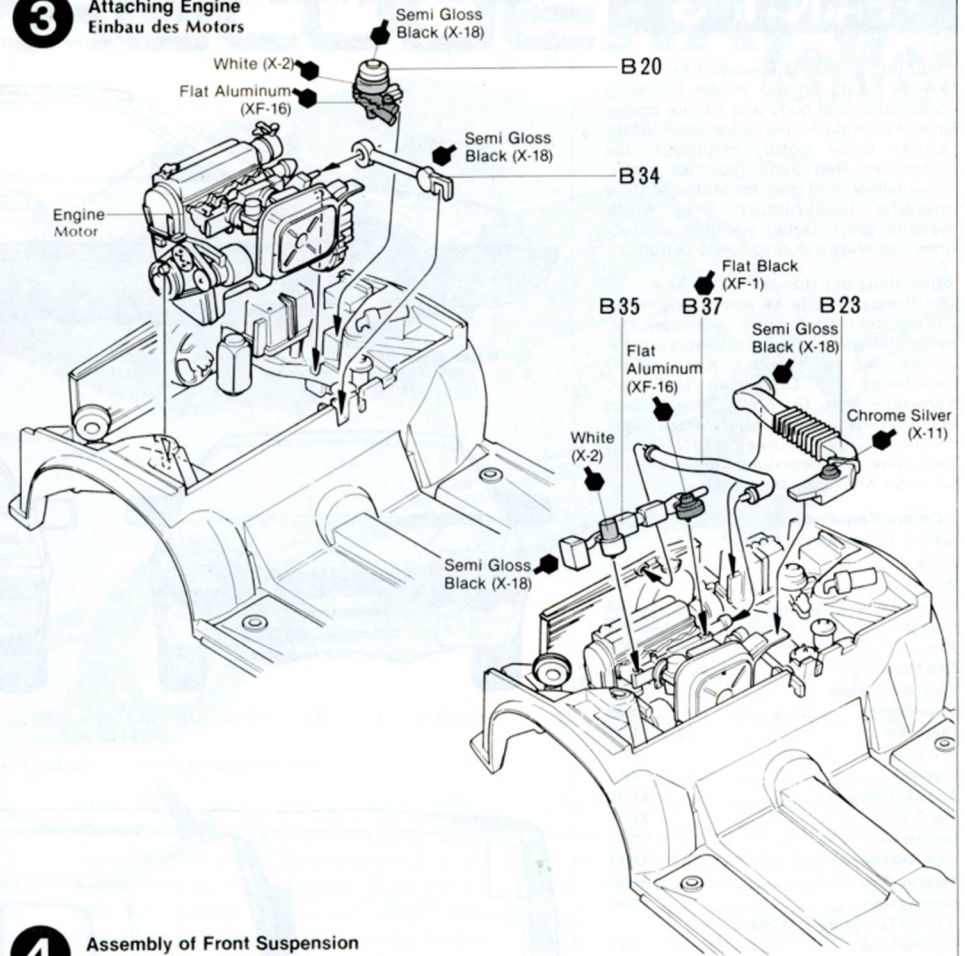

4 Assembly of Front Suspension
Vordere Achsaufhängung

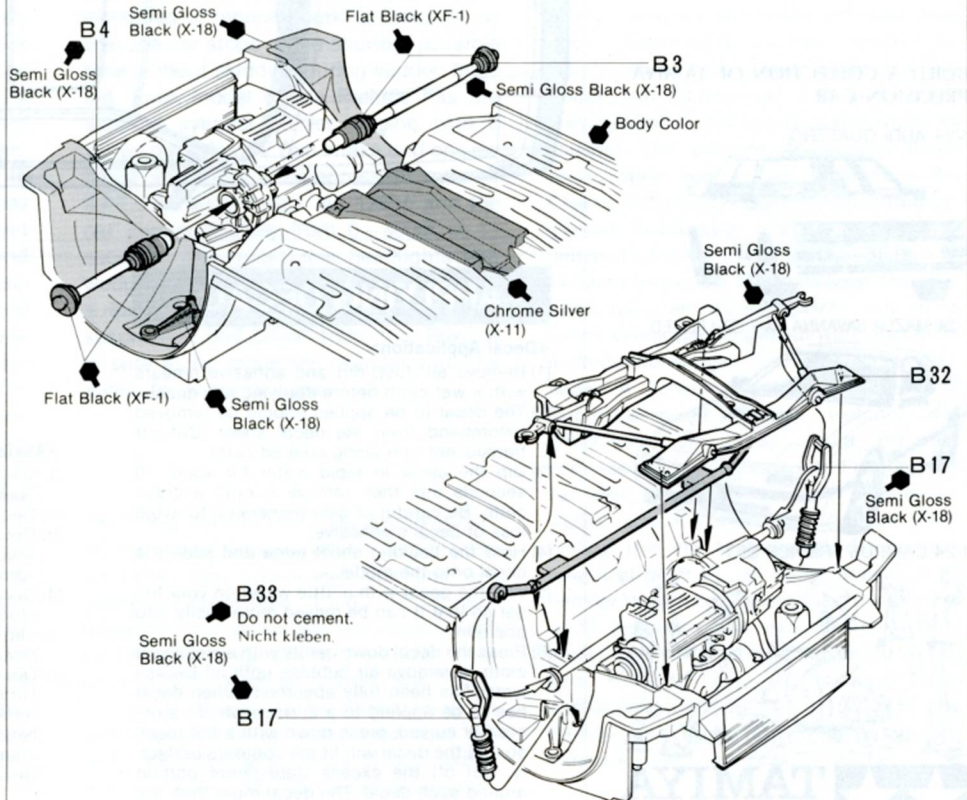

TAMIYA COLOR CATALOGUE
The latest in cars, boats, tanks and ships. Motorized, radio controlled and museum quality models are all shown in full color in Tamiya's latest catalogue. At your nearest hobby supply house.

5 «Attaching Tie Rods»
«Einbau der Spurstangen»

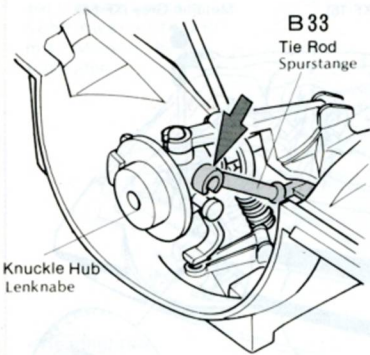

6 «Struts»
«Federbeine»

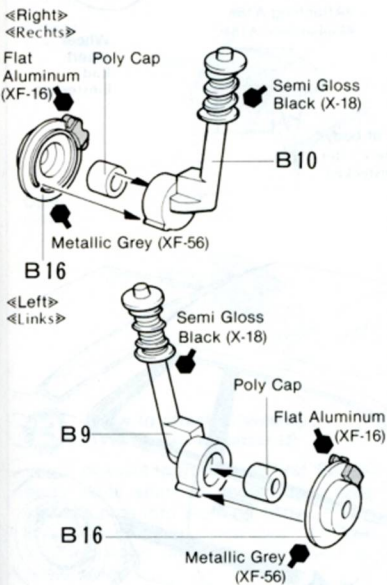

7 «Body and Interior Color»
«Karosserie und Innenfarbe»

Choose colors referring to diagram below and painting instructions on page 8. Coloring shown in each step is based on a car painted silver. () stands for interior color with red body color. Farbenwahl siehe Diagram unten und Bemalanleitung Seite 8. Anleitung in jedem Step ist für das Modell in silber. () = Innenfarbe für rote Karosserie.

Body Color	Interior Color
Greek White	Blue
Arctic Silver	Grey
Midnight Blue / Auburn Grey	
Dominican Red	Red/Black

TAMIYA CEMENT. HEXAGONAL BOTTLE
This is the same high quality Tamiya cement in a new Hexagonal bottle for increased stability. Difficult to upset and easy to use with the cap contained brush dispenser. The preferred plastic cement for experts and beginners alike.

5 Attaching Knuckle Hubs
Einbau der Lenknapen

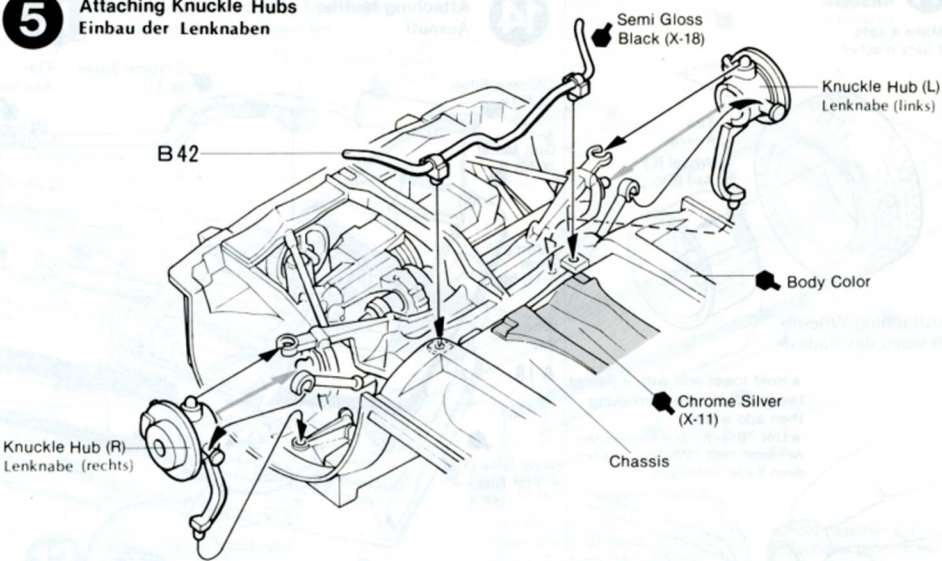

6 Rear Suspension
Hintere Achsaufhängung

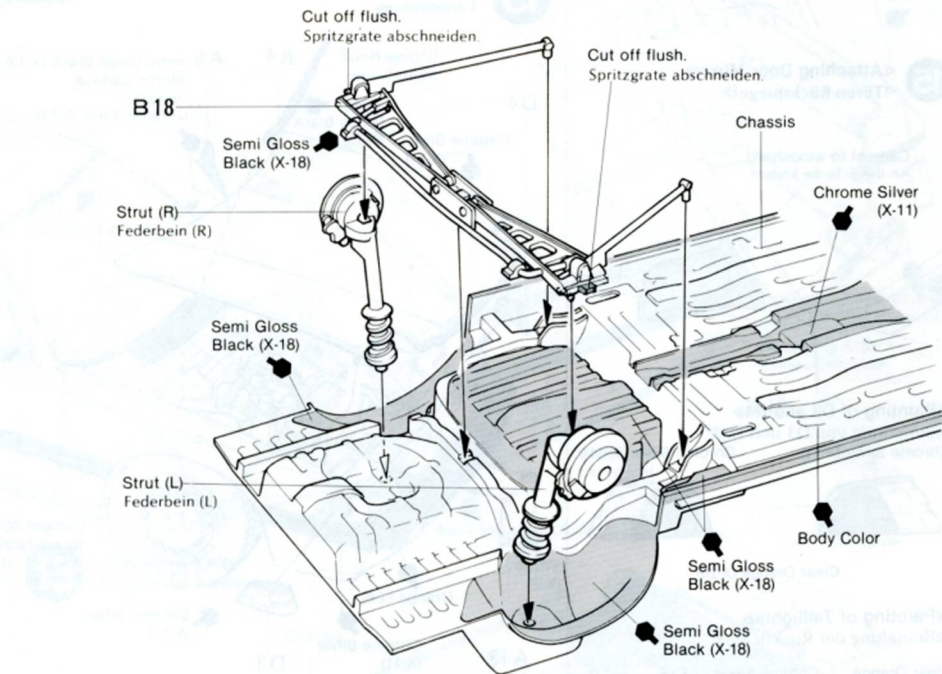

7 Assembly of Dashboard
Armaturenbrett

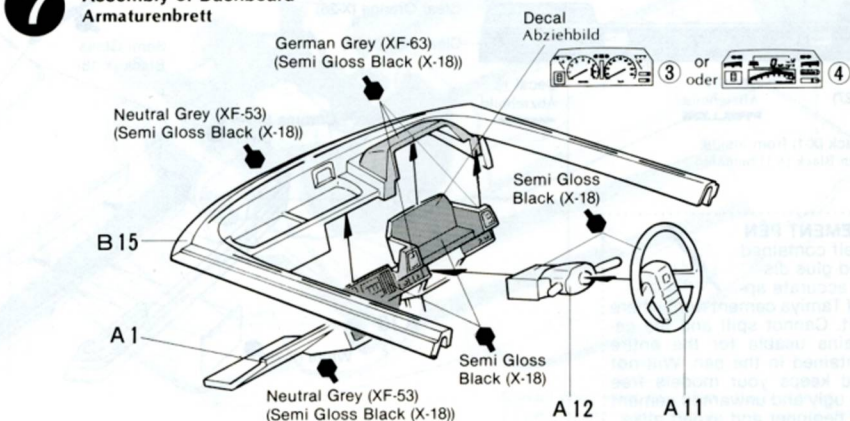

8 <<Assembly of Seats>> <<Sitze>>

Make 2 sets.
2 Satz machen.

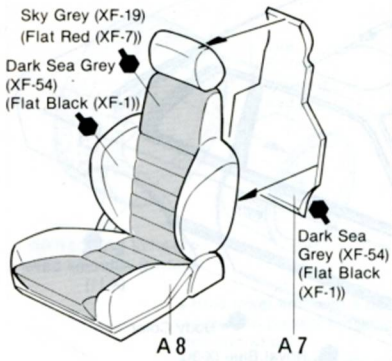

9 <<Interior>> <<Innere>>

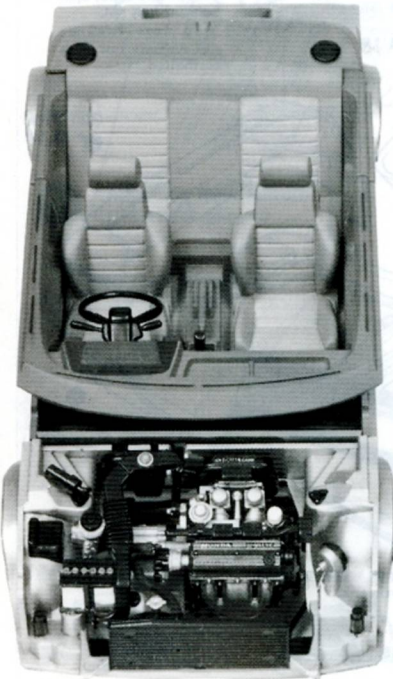

<<Painting of Body>> <<Bemalung der Karosserie>>

Apply overall painting to body prior to commencing assembly.
Zuerst Karosserie bemalen oder besprühen, dann erst weiterbauen.

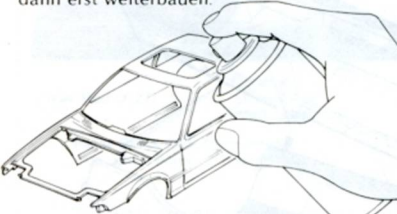

TAMIYA ACRYLIC PAINTS
Need precise color matching?
Try the new Tamiya acrylic paints. Engineered by modelers for modeler's use. The final cover for the finest models. Insist on Tamiya for perfect results.



8 Assembly of Interior Parts Innenteile

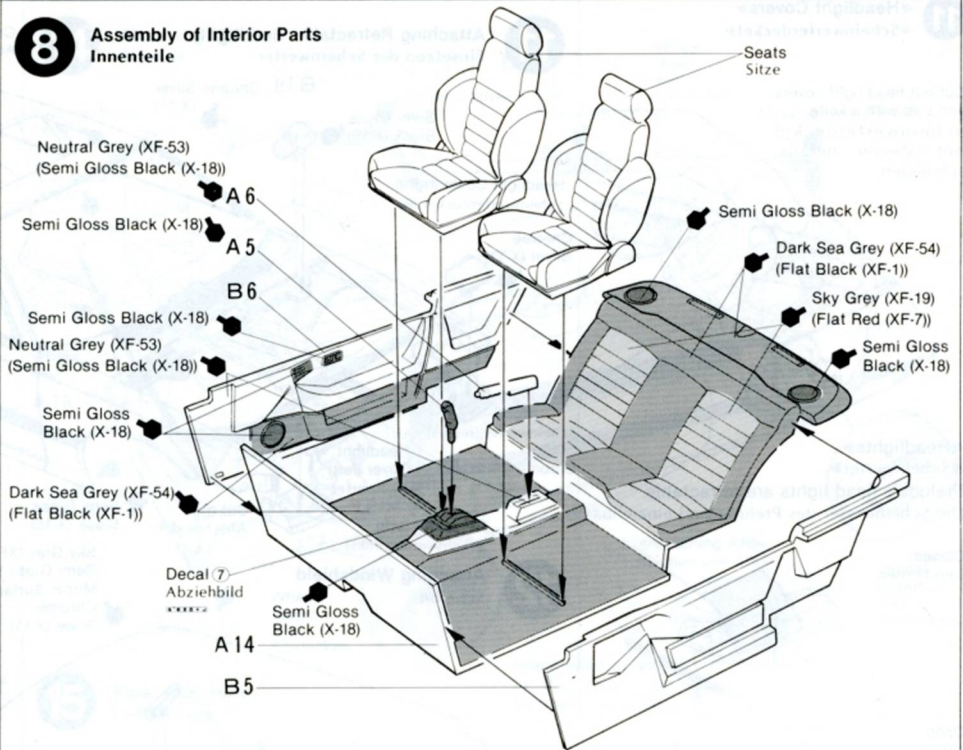

9 Attaching Inside Parts Einbau der Innenteile

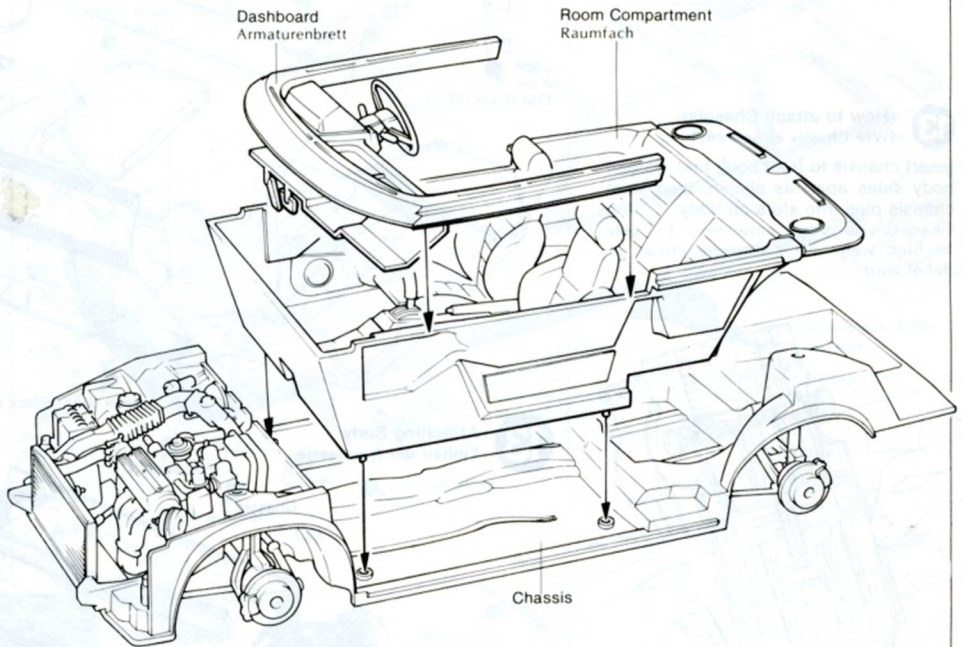

10 Assembly of Retractable Head Lights Zusammenbau der abklappbaren Scheinwerfer

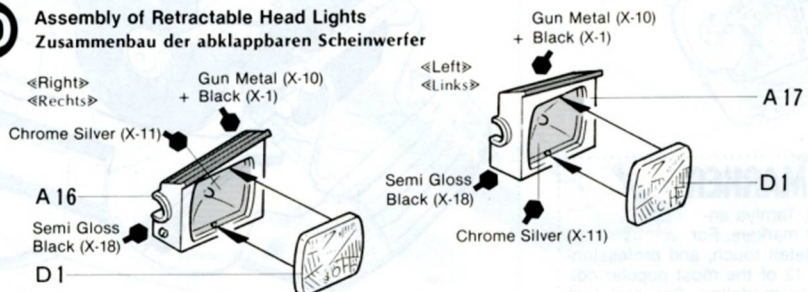

11 «Headlight Covers» «Scheinwerferdeckel»

Cut out head light covers and trim with a knife. Scheinwerferdeckel mit Messer heraus-schneiden.

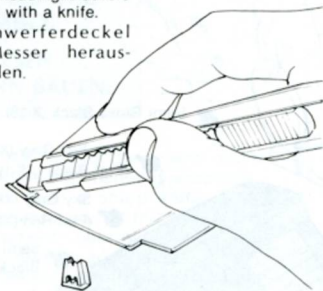

«Headlights» «Scheinwerfer»

Prelude's head lights are retractable. Die Scheinwerfer des Prelude sind einziehbar.

Closed
Geschlossen

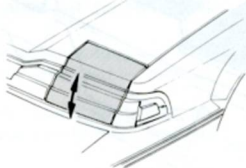

Open
Offen

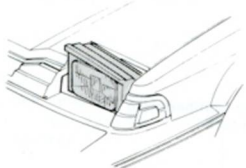

13 «How to attach Chassis» «Wie Chassis einsetzen?»

Insert chassis to front body first. Spread body sides apart as shown, then snap chassis pins into slots on body. Chassis von vorn einsetzen. Es geht leichter, wenn die Karosserie etwas gedehnt wird.

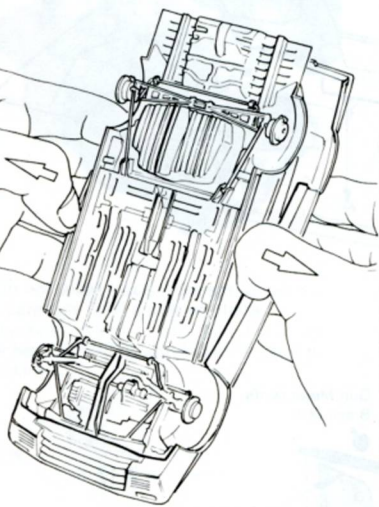

PAINT MARKER

Hand held, Tamiya enamel paint markers. For the final detail touch, and professional results. 12 of the most popular colors used in modeling. See and test them at your local hobby supply house.

11 Attaching Retractable Headlights Einsetzen der Scheinwerfer

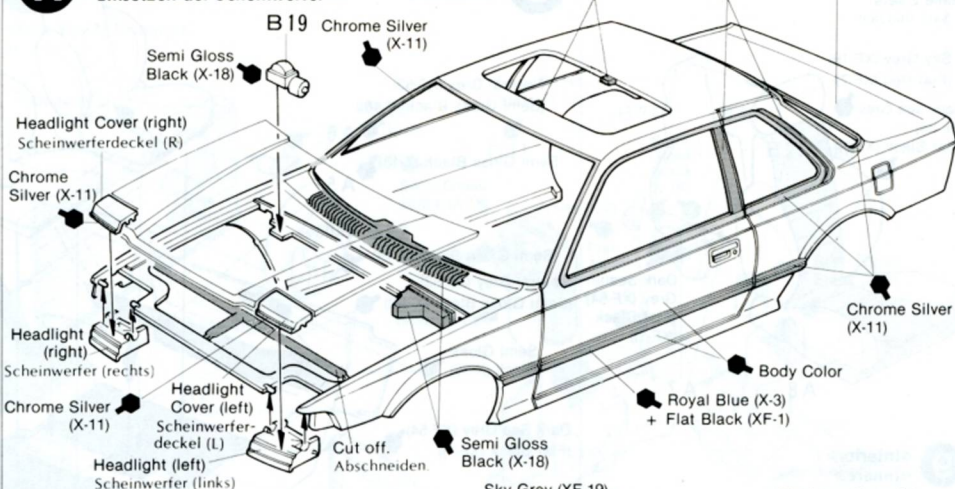

12 Attaching Windshield Scheibe

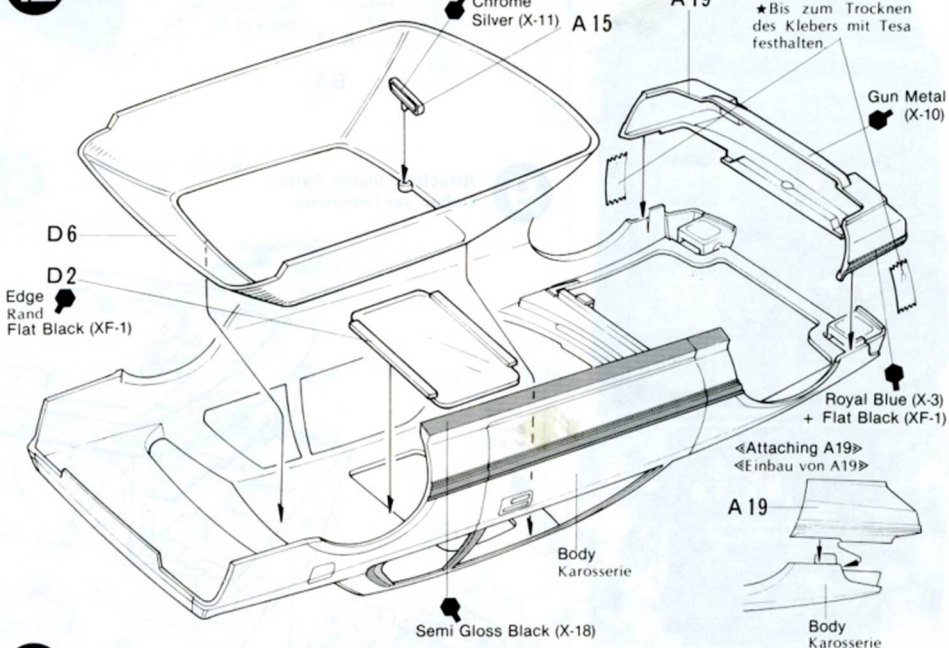

13 Attaching Body Einbau der Karosserie

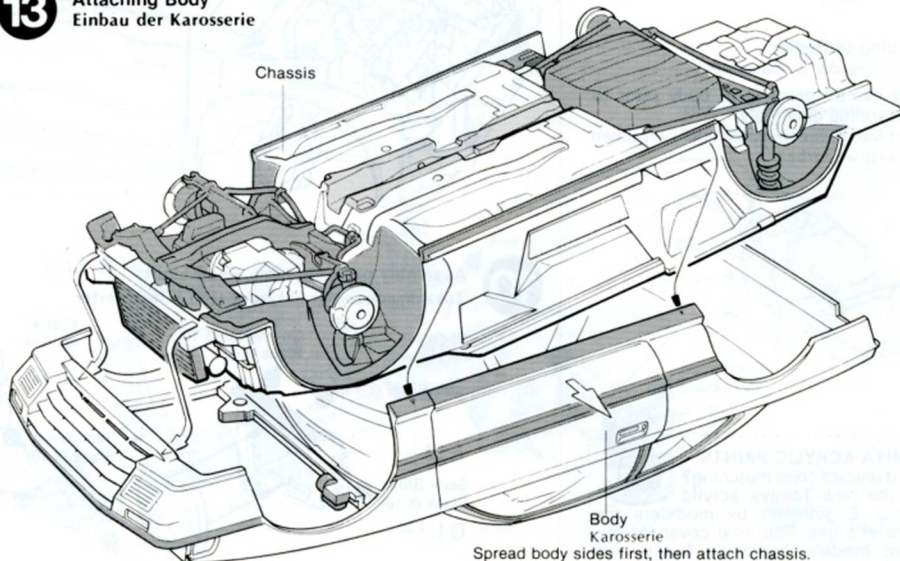

Spread body sides first, then attach chassis. Es geht leichter wenn die Karosserie etwas gedehnt wird.

14 «Wheels» «Räder»

Make 4 sets.
4 Satz machen

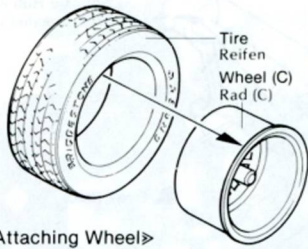

«Attaching Wheel» «Einbau des Rades»

- ★ Hold lower arm with a pair of tweezers to prevent breaking, then add wheel.
- ★ Um Bruch zu vermeiden, Achsarm mit Pinzette halten, dann Räder anbringen.

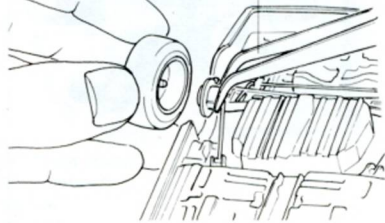

15 «Attaching Door Mirror» «Türen-Rückspiegel»

Cement to windshield.
An die Scheibe kleben.

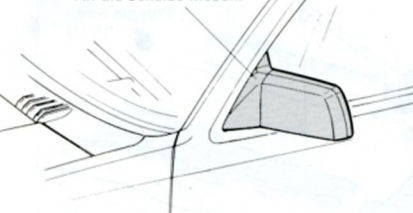

«Painting of D3 and D4» «Bemalung von D3 und D4»

Chrome Silver (X-11) Chrome Silver (X-11)



Clear Orange (X-26)

«Painting of Taillights» «Bemalung der Rücklichte»

Clear Orange (X-26) Chrome Silver (X-11) D5



Clear Red (X-27)

Decal 5
Abziehbild
PRELUDE

Paint Black (X-1) from inside.
Von innen Black (X-1) bemalen

TAMIYA CEMENT PEN

A handy self contained pencil sized glue dispenser for accurate application of Tamiya cement right where you want it. Cannot spill and the cement remains usable for the entire supply contained in the pen. Will not dry up and keeps your models free from those ugly and unwanted cement stains. For beginner and expert alike.

14 Attaching Muffler Auspuff

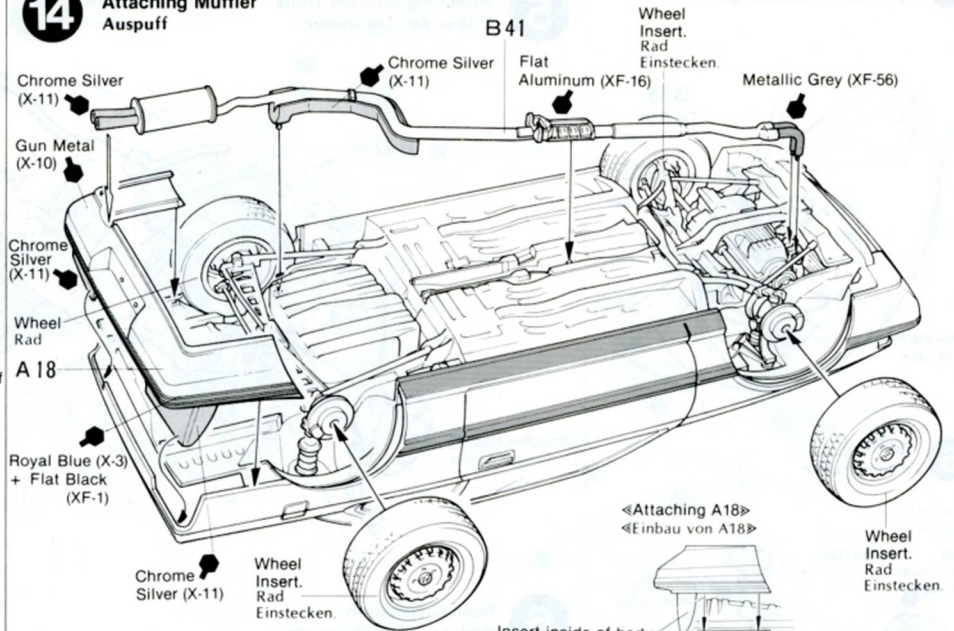

«Attaching A18» «Einbau von A18»



Insert inside of body.
In das Innere der Karosserie einstecken.

15 Final Assembly Endmontage

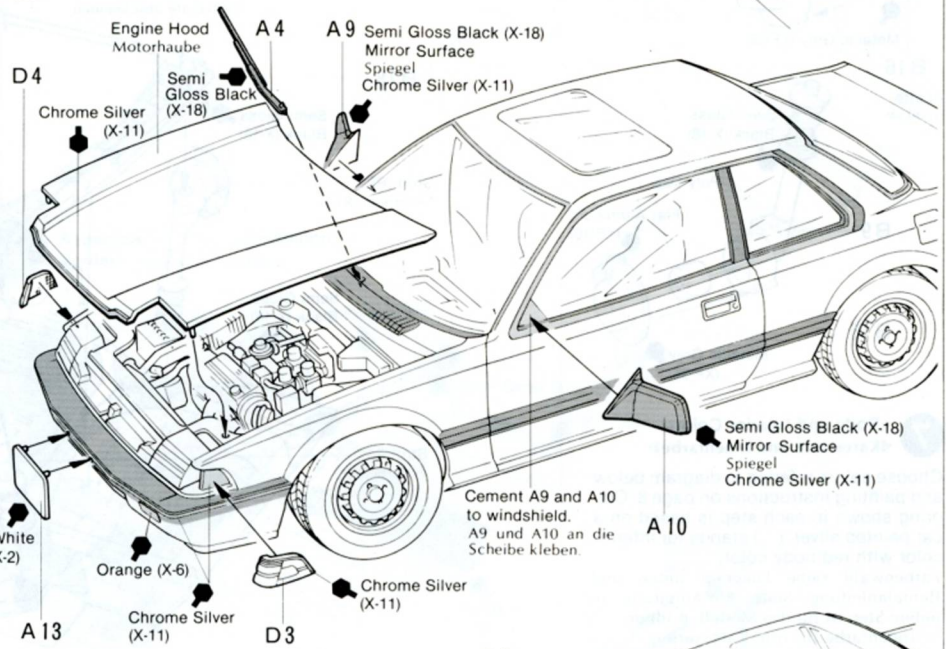

PAINTING

«Painting of Honda Prelude XX»

Prelude XX is offered in the following combinations of body and interior colors Blue or blue/black interior for Greek White (white) body color, red/black for Dominican Red (red), grey for Arctic Silver (silver) and grey for Midnight Blue (metallic blue)/Auburn Grey (dark metallic grey). Detail painting instructions are shown during construction.

«Bemalung des Honda Prelude XX»

Der Honda Prelude XX wird in folgenden Farbzusammenstellungen angeboten. Inneneinrichtung blau oder blau/schwarz für Greek white (weiss) Karosserie, rot/schwarz für Dominican Red (rot) Karosserie, grau für Arctic Silver (silber) und grau für Midnight blue (Metall-blau)/Auburn Grey (dunkel Metall-grau) Karosserie. Die Bemalung kleiner Details ist in der Anleitung angegeben.

«Colors Required»

★ From Tamiya Acrylic Paints

Black	X-1
White	X-2
Royal Blue	X-3
Orange	X-6
Red	X-7
Gun Metal	X-10
Semi Gloss Black	X-18
Clear Orange	X-26
Clear Red	X-27
Flat Black	XF-1
Flat Red	XF-7
Flat Aluminum	XF-16
Sky Grey	XF-19
Neutral Grey	XF-53
Dark Sea Grey	XF-54
Metallic Grey	XF-56
German Grey	XF-63

★ From Tamiya Paint Markers

Chrome Silver	X-11
---------------------	------

BUILD A COLLECTION OF TAMIYA PRECISION CAR

1/24 AUDI QUATTRO



1/24 MAZDA SAVANNA RX-7 GT-LIMITED



1/24 CAMPUS FRIENDS SET



«Painting and Marking of Honda Prelude XX»

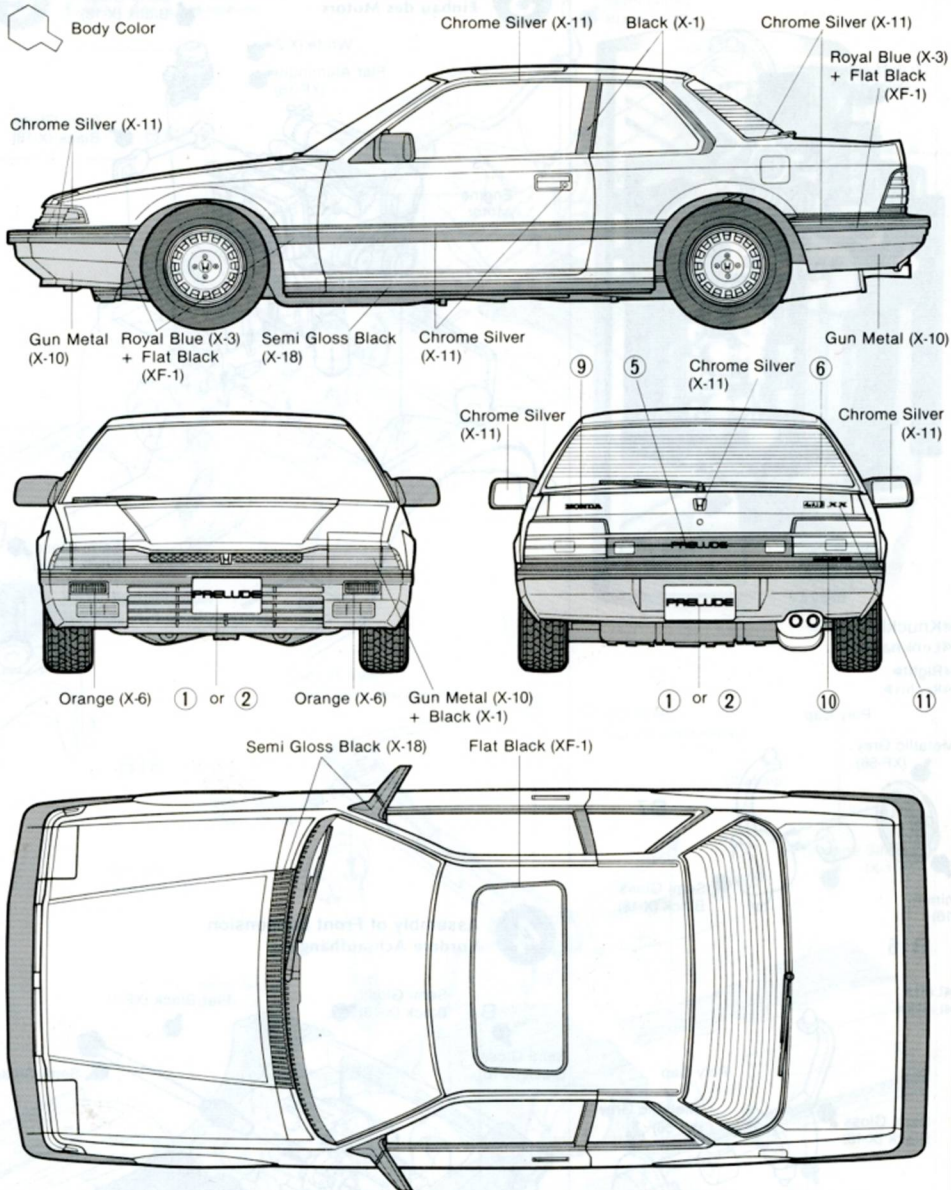

APPLYING DECALS

«Decal Application»

- (1) Remove all dust, dirt and adhesive smears with a wet cloth before applying any decals.
- (2) The decal to be applied should be removed beforehand from the decal sheet. Cut off translucent film along colored parts.
- (3) Dip the decal in tepid water for about 10 seconds and then remove it onto a clean cloth. Be careful of over immersion to avoid loss of decal's adhesive.
- (4) Hold the backing sheet edge and slide the decal onto the model.
- (5) Wet the decal with a little water on your finger so that it can be moved more easily into position.
- (6) Press the decal down gently with a clean soft cloth to remove air bubbles until all excess water has been fully absorbed. When decal has to be applied to a surface which is uneven or curved, press down with a hot towel so that the decal will fit the contours perfectly. Cut off the excess transparent portion around each decal. The decal must then not be touched until dry.



«Abziehbilder-Decals»

- (1) Staub, Schmutz und Klebstoffreste mit nassem Tuch entfernen.
- (2) Decals erst ausschneiden entlang den Linien.
- (3) Decals in Wasser legen, dann nach 10 Sekunden auf z.B. Handtuch legen und etwas abtrocknen lassen.
- (4) Decal an der Unterlage halten und Bild auf das Modell schieben.
- (5) Mit etwas Wasser auf dem Finger lässt sich das Decal noch etwas verschieben.
- (6) Decal mit etwas Stoff gut andrücken, um die Luftblasen zu entfernen und das Wasser abzutrocknen. An unebenen Stellen kann man mit heissen Tuch das Decal besser andrücken. Transparente Überreste am Decal abschneiden. Decal nicht mehr berühren, bis getrocknet ist.