

1/350 SCALE

ITEM NO.:05349

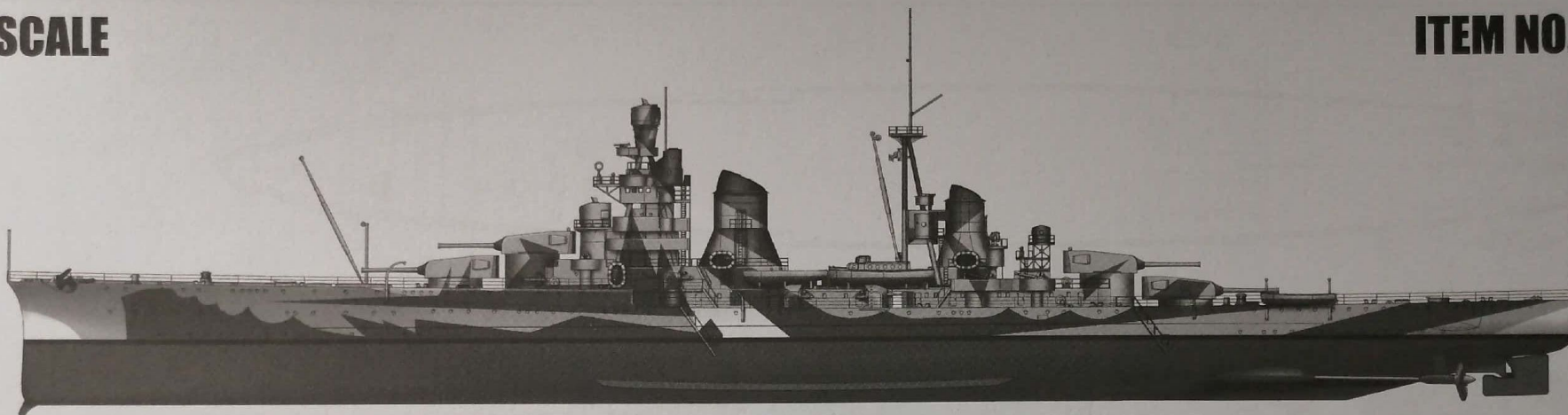

Italian Heavy Cruiser Gorizia

意大利海军“戈里齐亚”号重型巡洋舰

READ BEFORE ASSEMBLY:

- This kit is not recommended for inexperienced modelers or for children under 14 years of age
- Study and understand these instructions thoroughly before beginning assembly
- When needed, remove photo-etch parts carefully using a modeling knife or photo etch sprue cutter, being careful not to damage or lose small parts.
- Take extra care in handling photo etch parts in order to avoid injury
- Apply instant cement sparingly to photo etch parts where instructed
- Tools recommended(not included in kit):Plastic and instant cements,sprue cutters,long nose pliers,modeling knife, small files, tweezers, pin vise & scissors. Soft cloth and sandpaper will also assist in construction
- Glue and paint are not included in the kit. Use plastic cement and hobby paints only. Color guide for purchasing paint is included in the kit.
- Keep out of reach of children. They must not be allowed to ingest small parts or handle plastic bags in any way.

*说明书中含有重要信息，应保留。 Please Keep instruction since it contains important information.

装配之前仔细阅读

- 小心用模型锉刀锉平所有零件表面的注射浇口。
- 小心用刀片切下蚀刻片零件，不要遗失小零件。
- 用强力快干胶水粘合蚀刻片零件和金属轴。过量的快干胶水使用可能导致可动零件会粘住，小心涂胶。
- 取蚀刻片时应特别注意安全，防止利边划伤手指。
- 某些零件表面需贴水上贴纸，请选择在装配的同时进行。
- 推荐模型工具(自备)：胶水，水口剪刀，长咀钳，刀片，锉刀，镊子钳，钻，剪刀，瞬间快干胶。
- 软布同砂纸同时也是所需工具。
- 请使用塑料胶水和油漆，模型内不含有。
- 谨防小孩吸吮塑料零件，或者将塑料袋套在头上，制作时应将套材远离小孩接触。
- 本产品不适合14岁以下没有经验的模型爱好者。

水贴纸的使用:

1. 从水贴上剪下印花;
2. 将印花放入温水中浸10秒，然后放在干净布上。
3. 拿着印花纸板将印花移到模型上;
4. 手指蘸水将印花移到适当的位置;
5. 用软布轻压印花直至水干，汽泡消失。

DECAL APPLICATION:

1. Cut decals from sheet as needed
2. Dip the decal in warm water for about 10 seconds and then place on soft clean cloth.
3. Hold the decal backing sheet edge and gently slide the decal onto the model in its proper position.

4. While still wet,decal can be adjusted for better fit on model by dampening it gently with your finger.
5. When placed in the proper position,gently press decal down with a soft cloth until excess water and air bubbles are gone.
6. Allow decal to dry completely before handling model



部品图 Parts

《船体》
Hull(P版)

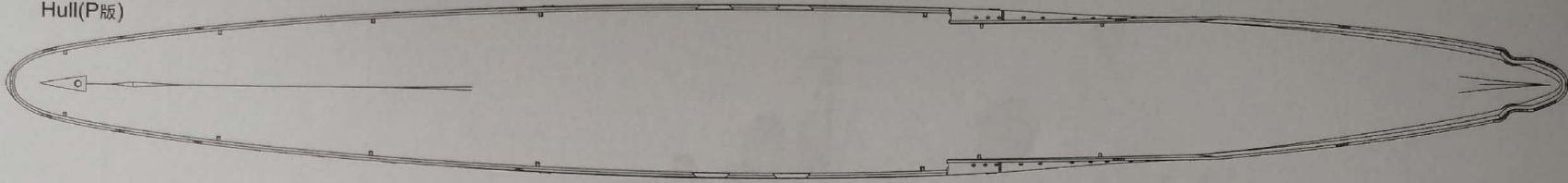

《后甲板》
Rear deck(Q2版)

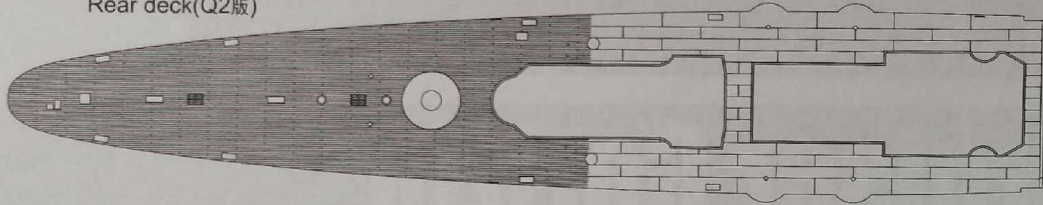

《前甲板》
Fore deck(Q1版)

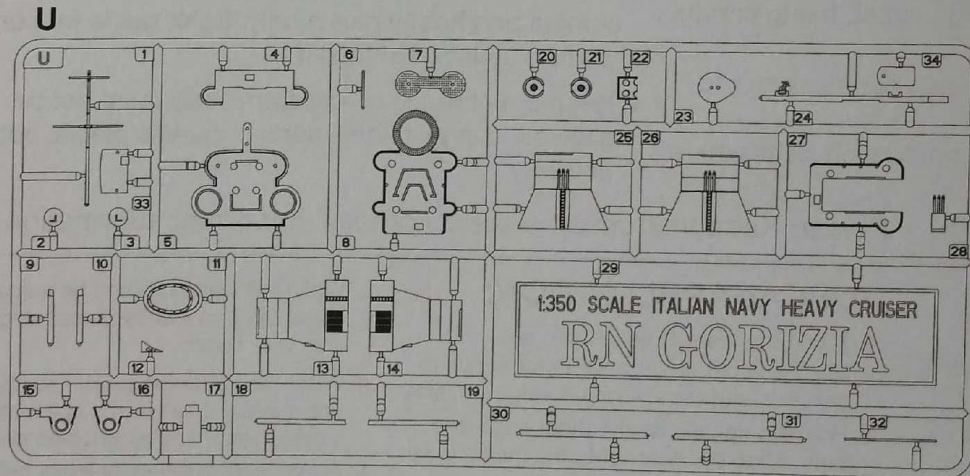
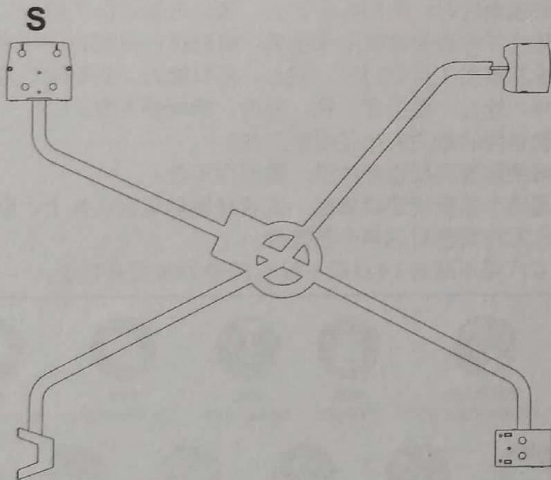
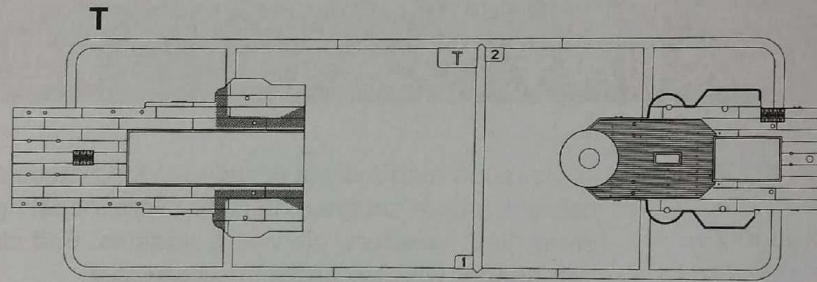
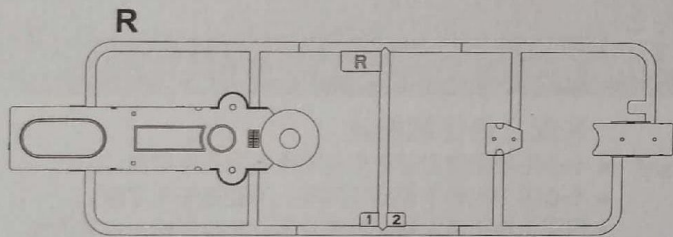
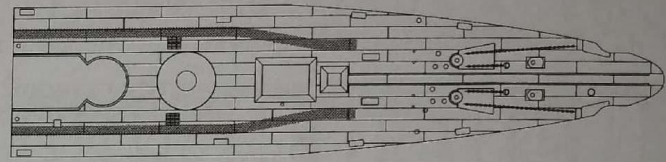

部品图 Parts

Y1

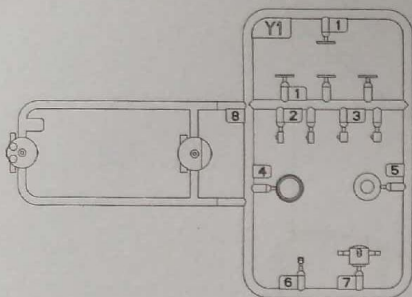

Y2

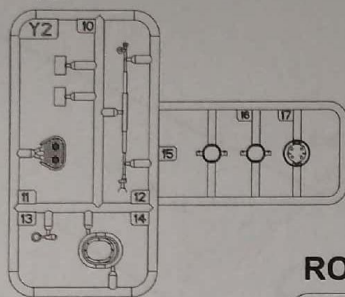

X2x2

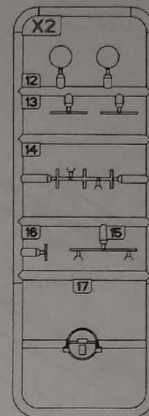

X3x2

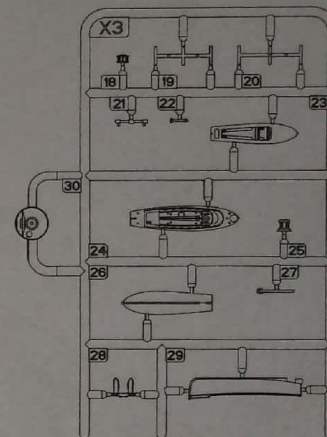

RO.43

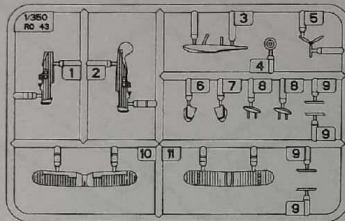

V

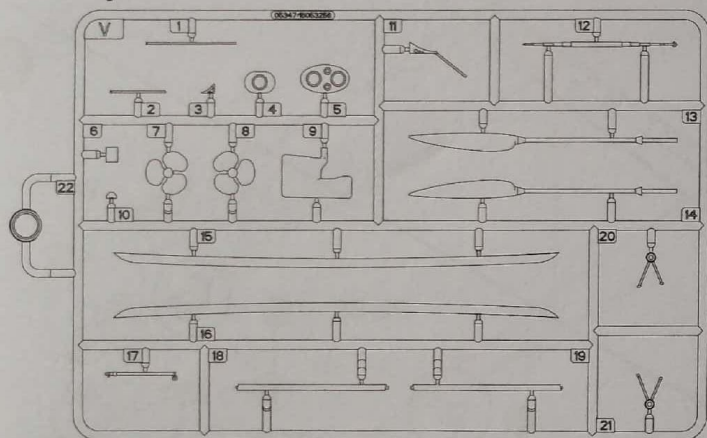

座架 Stand

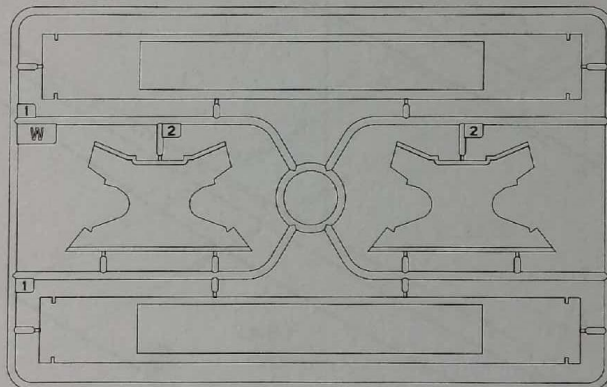

PE-D

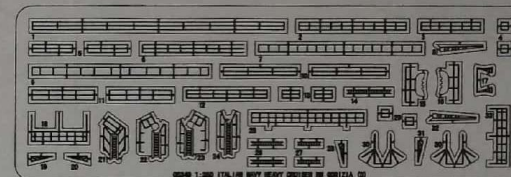

PE-B

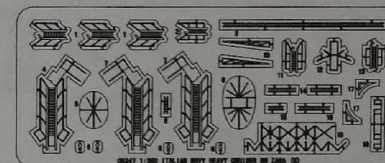

PE-Ex2

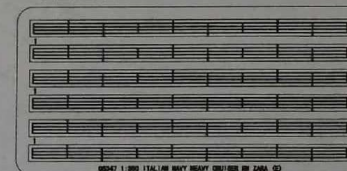

Wx4

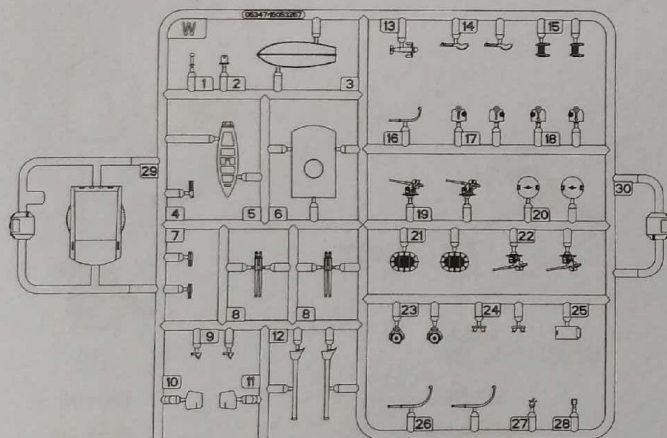

《水贴》
Decal



1

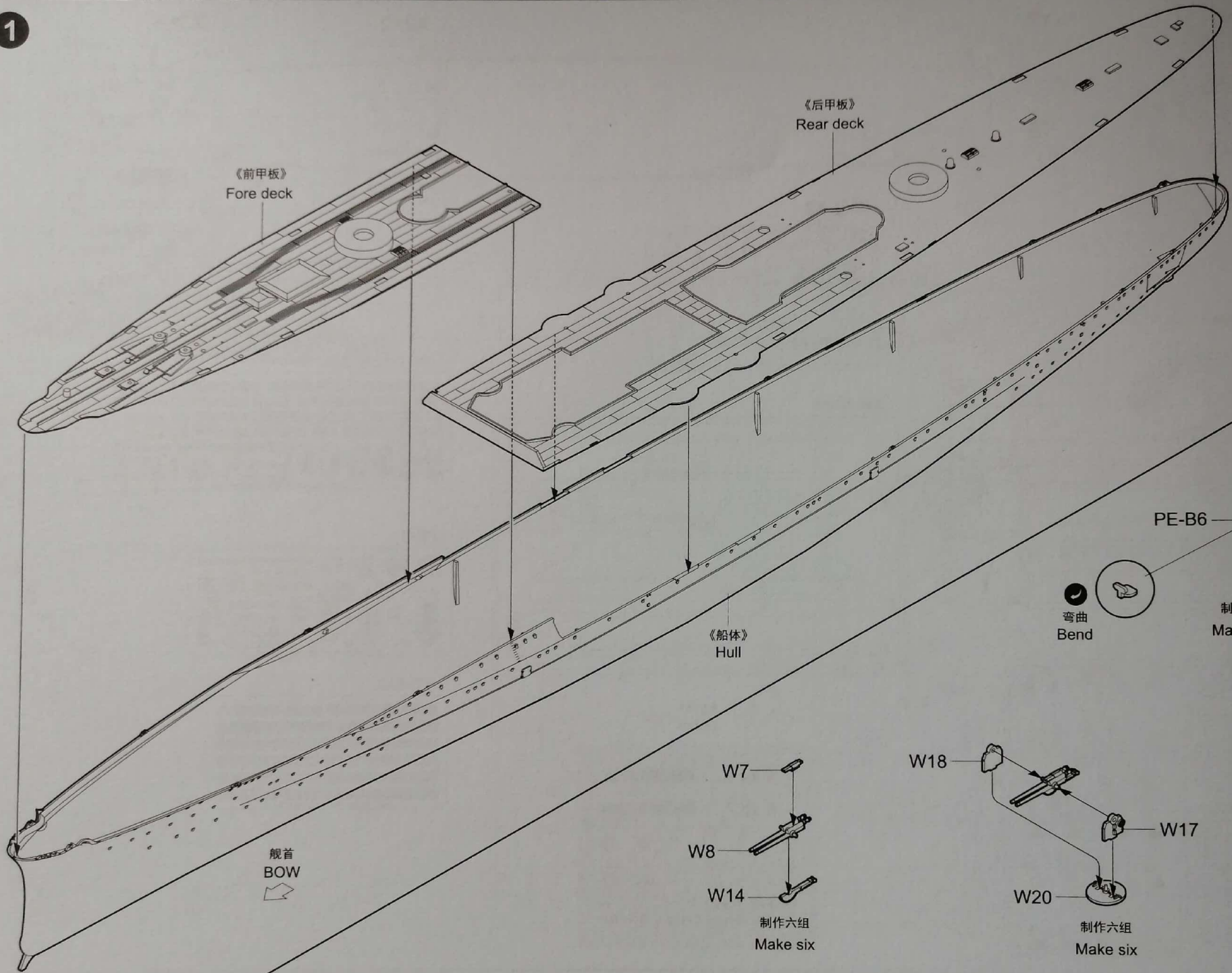

2

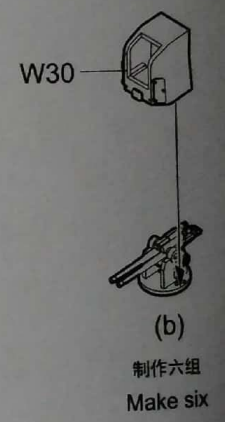
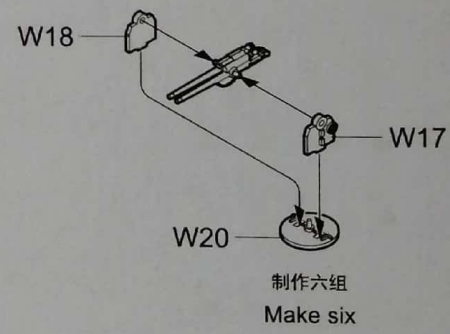
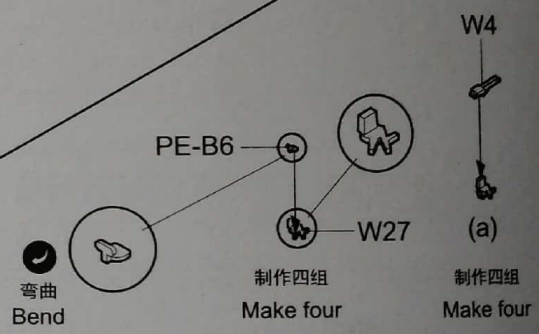

3

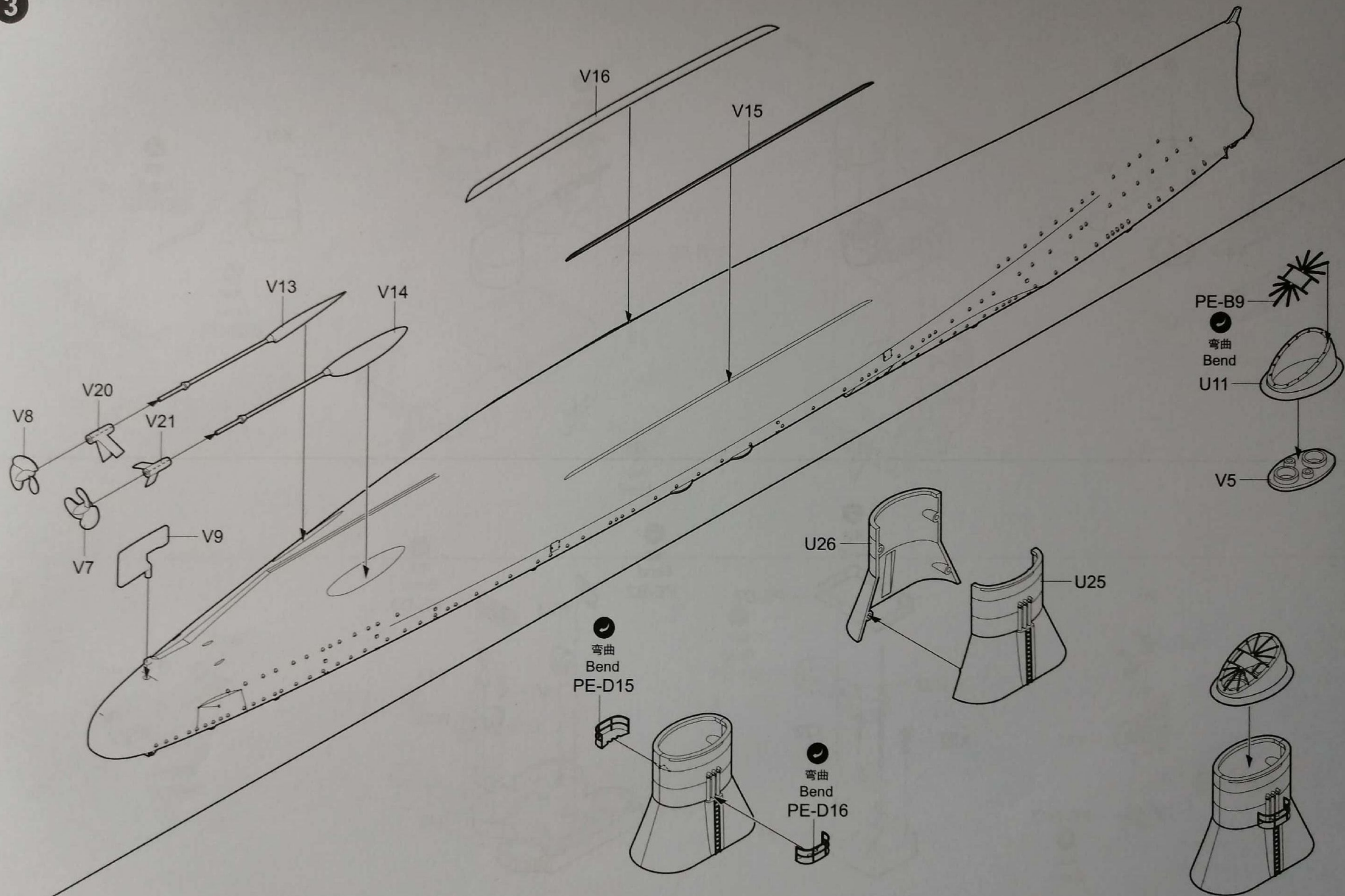

4

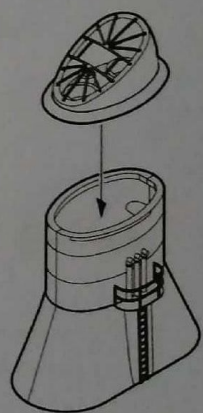

5

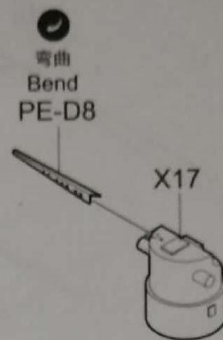
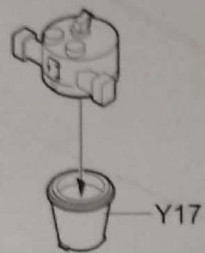
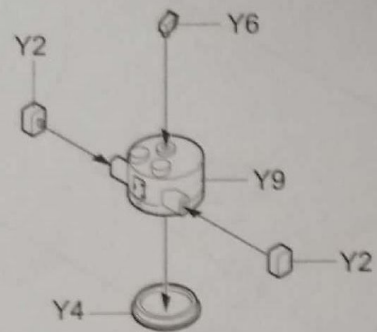

6

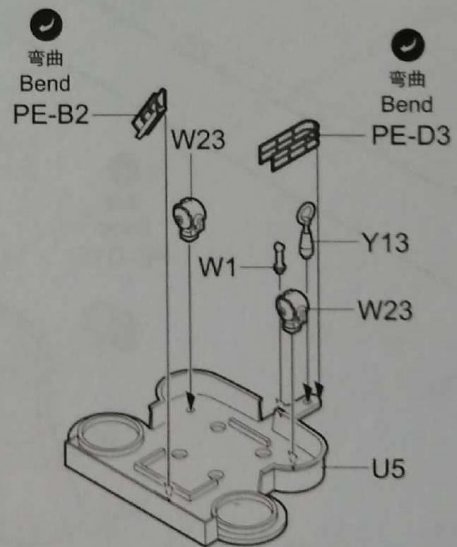
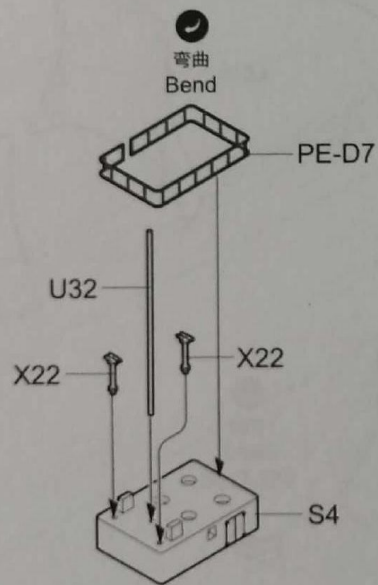
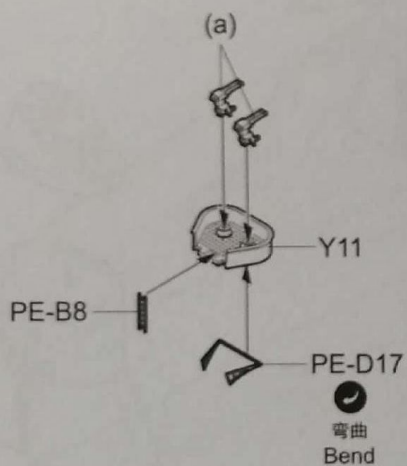

7

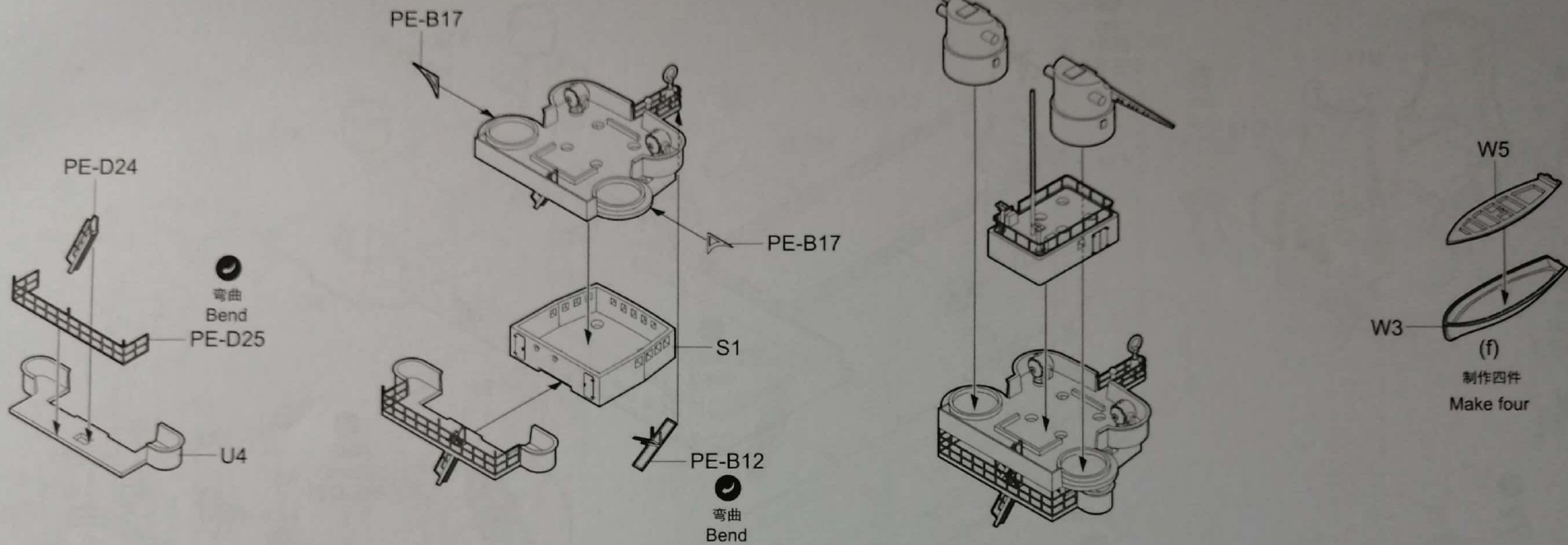

8

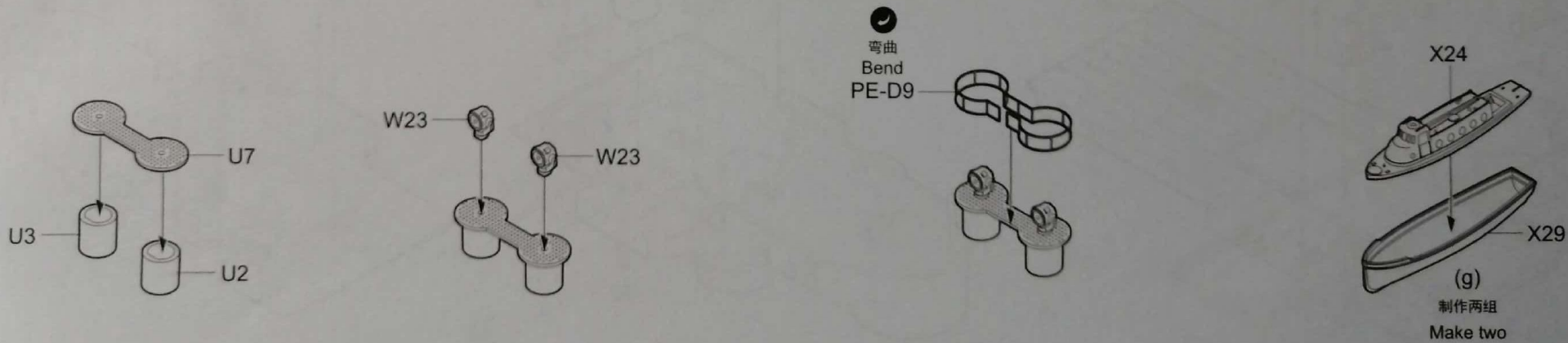

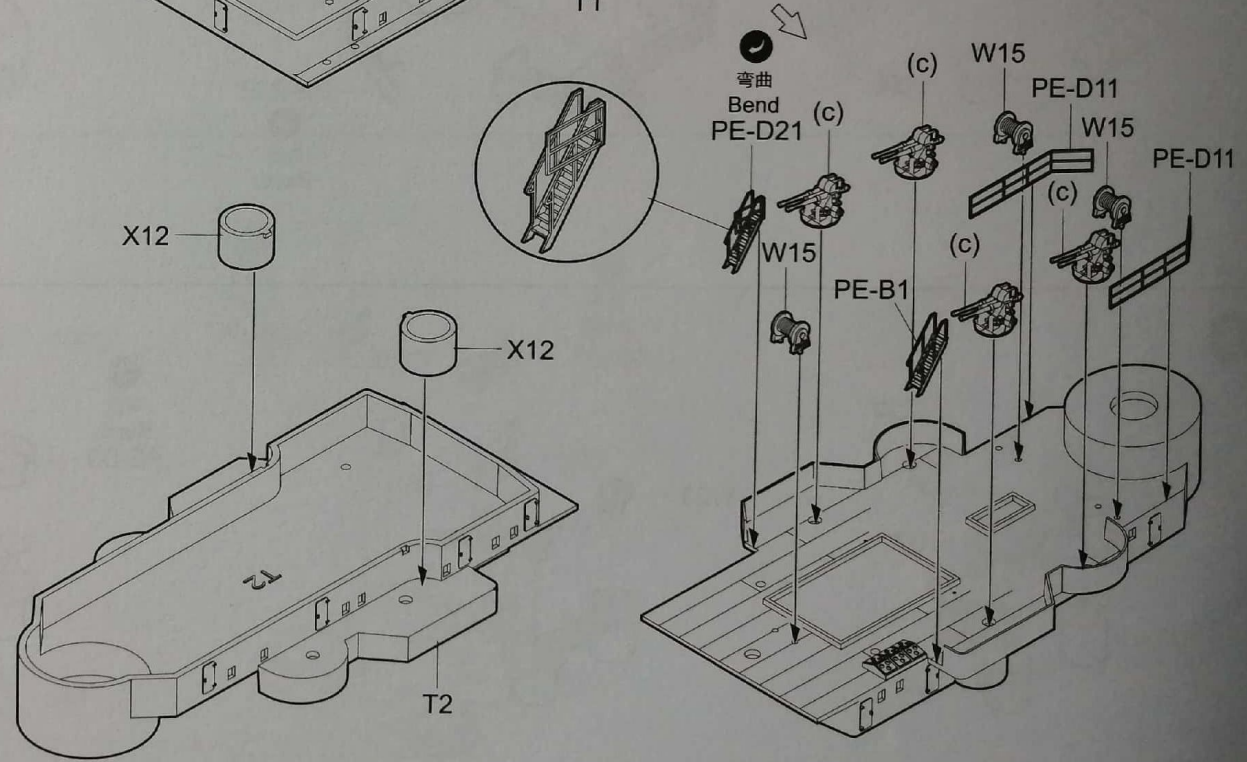
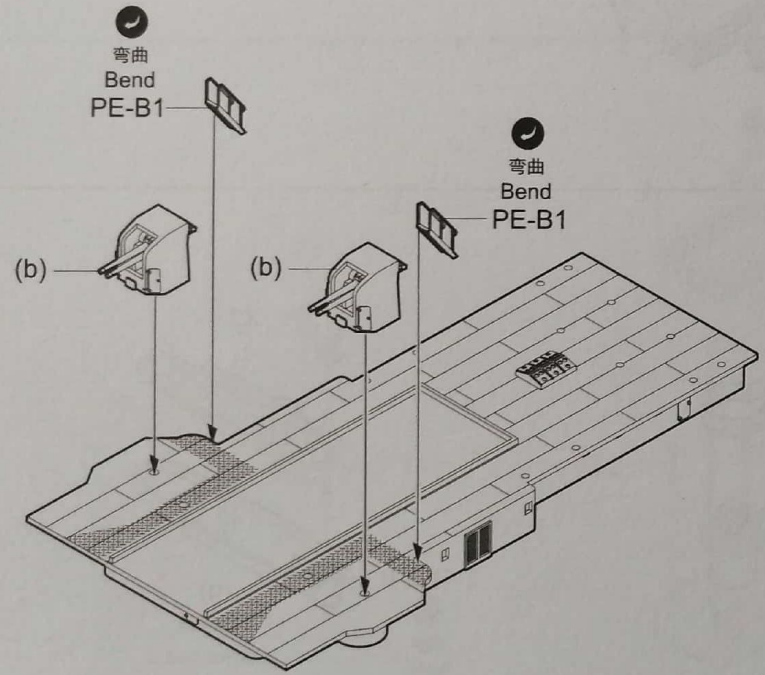
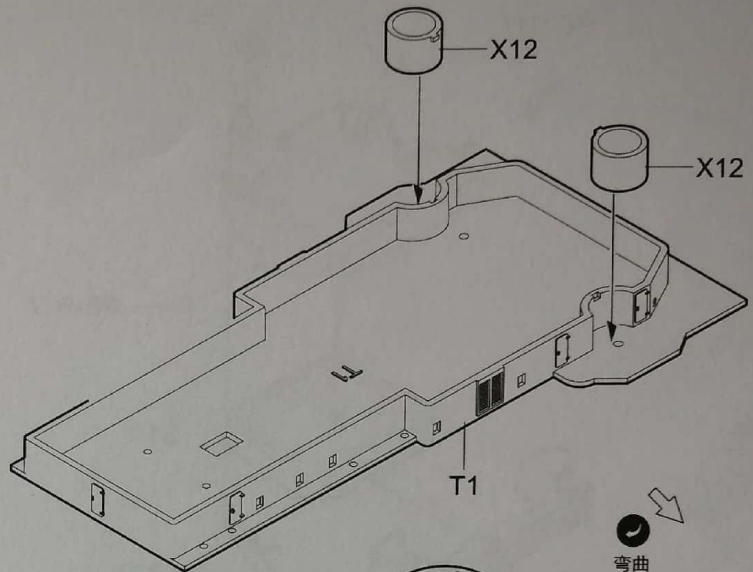
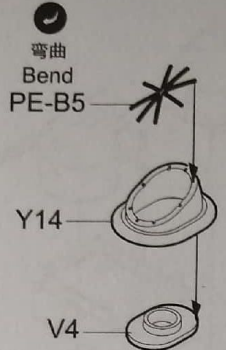
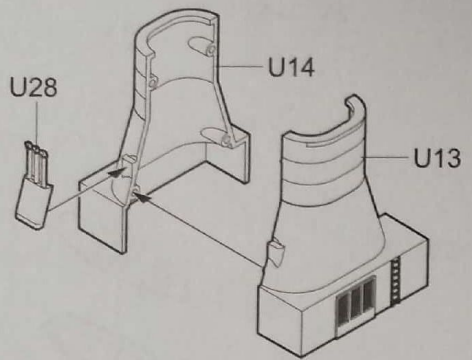

10

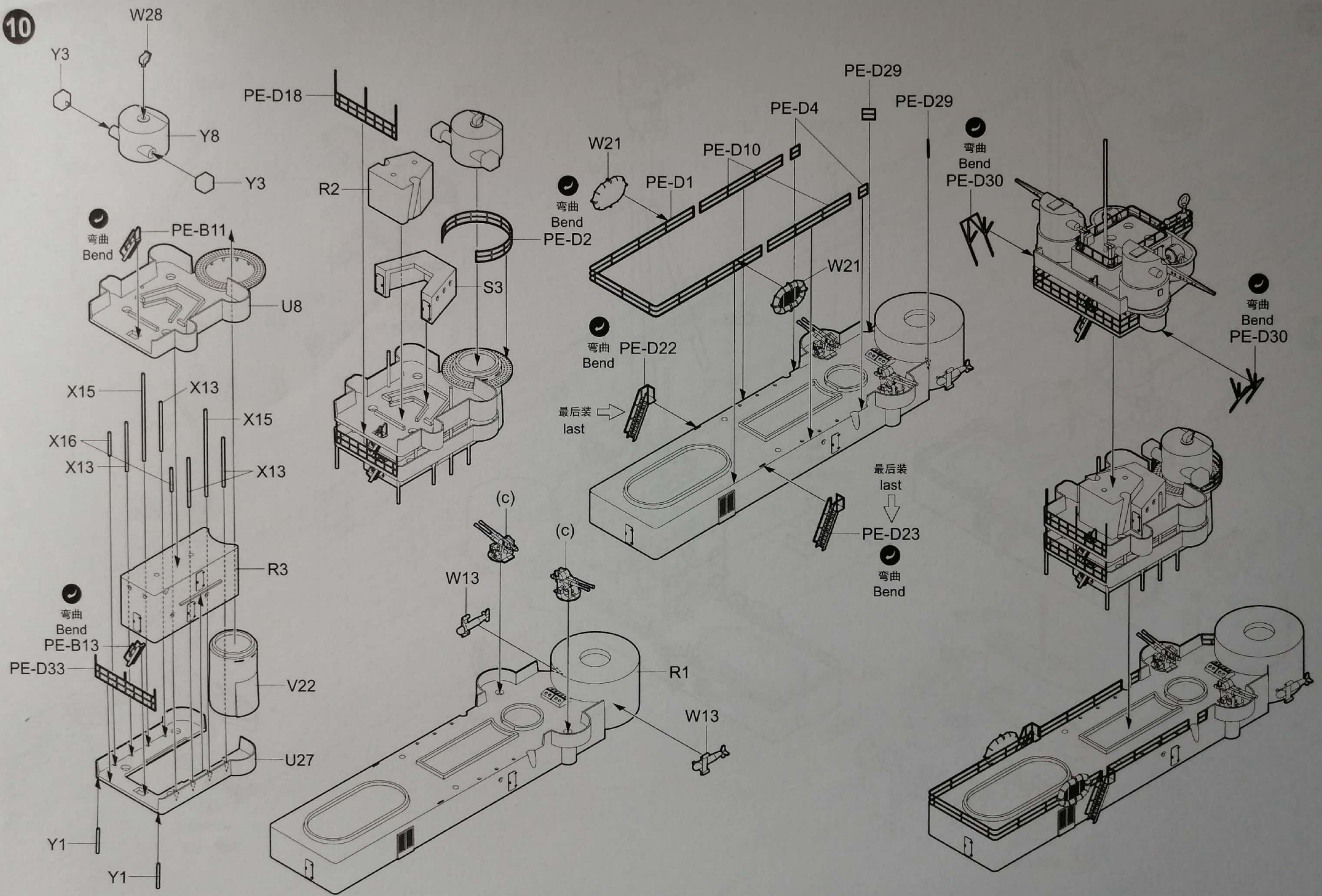

最后装
last

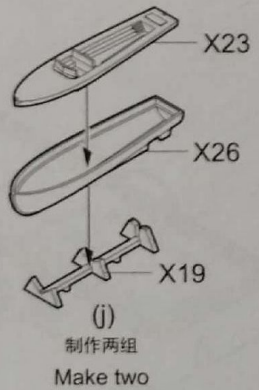
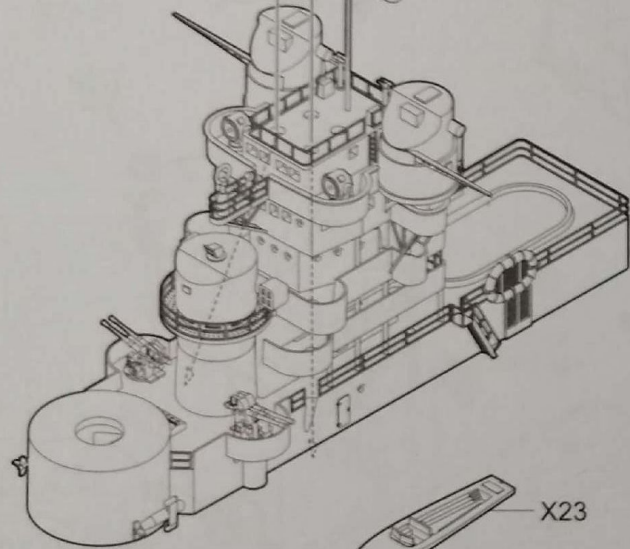
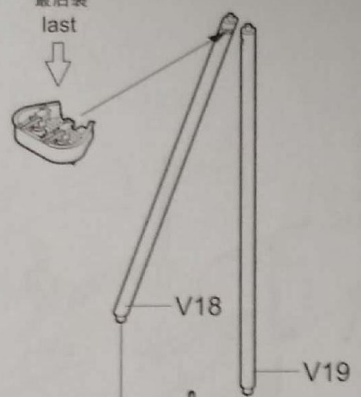

先装
Install it first

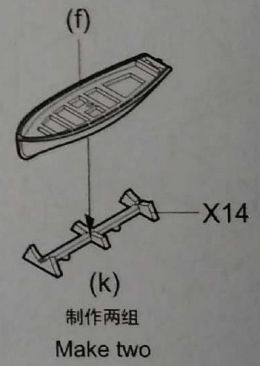
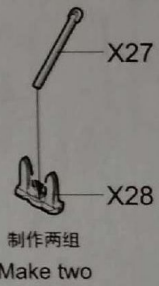
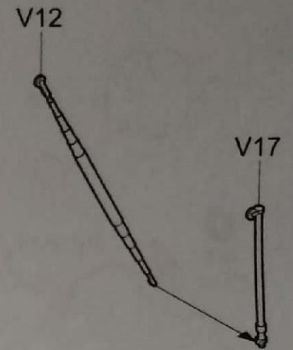
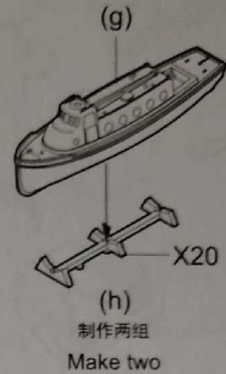
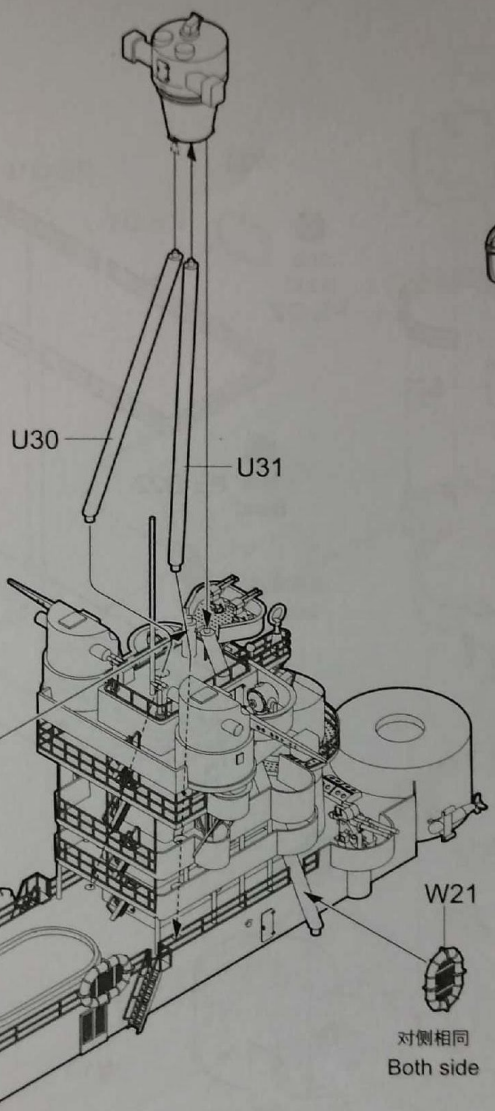
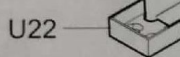

12

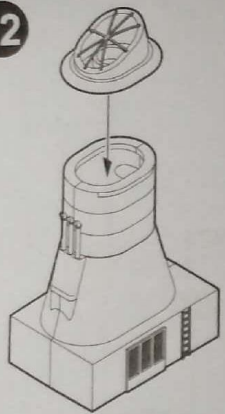

13

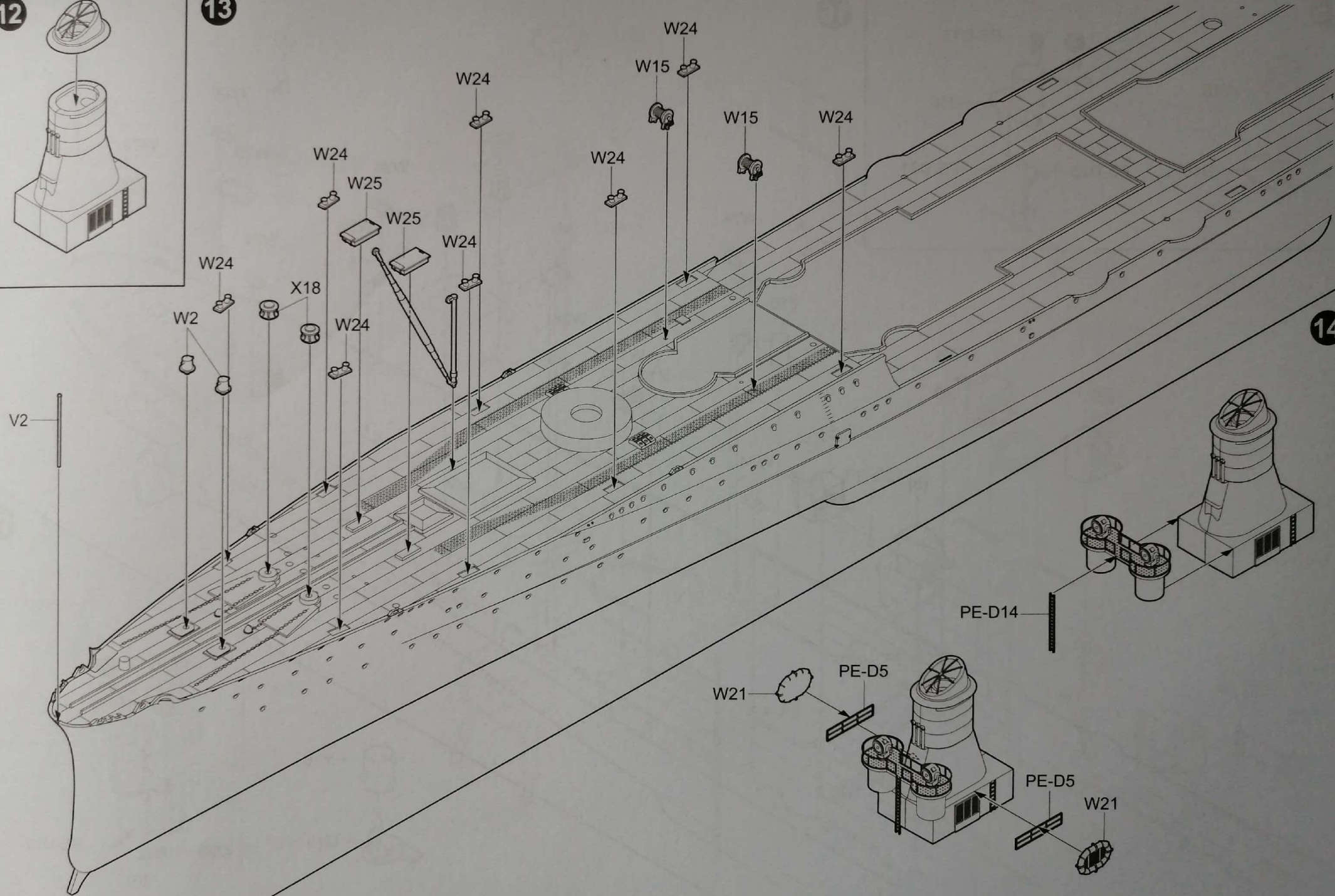

14

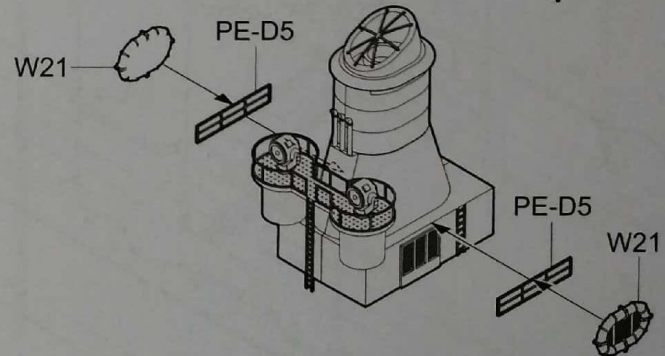
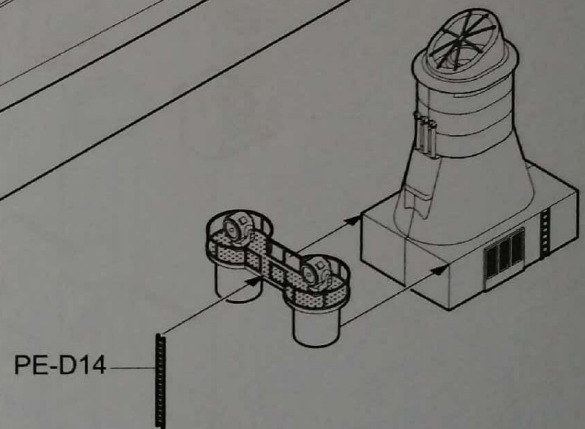

15

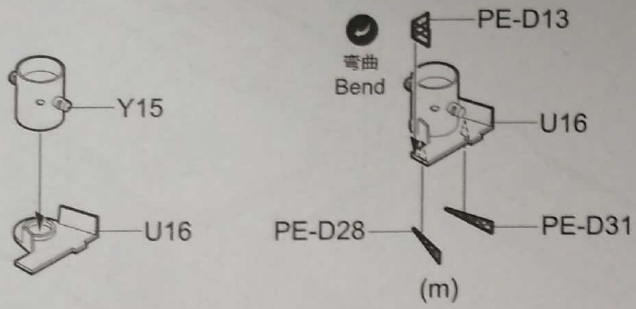

16

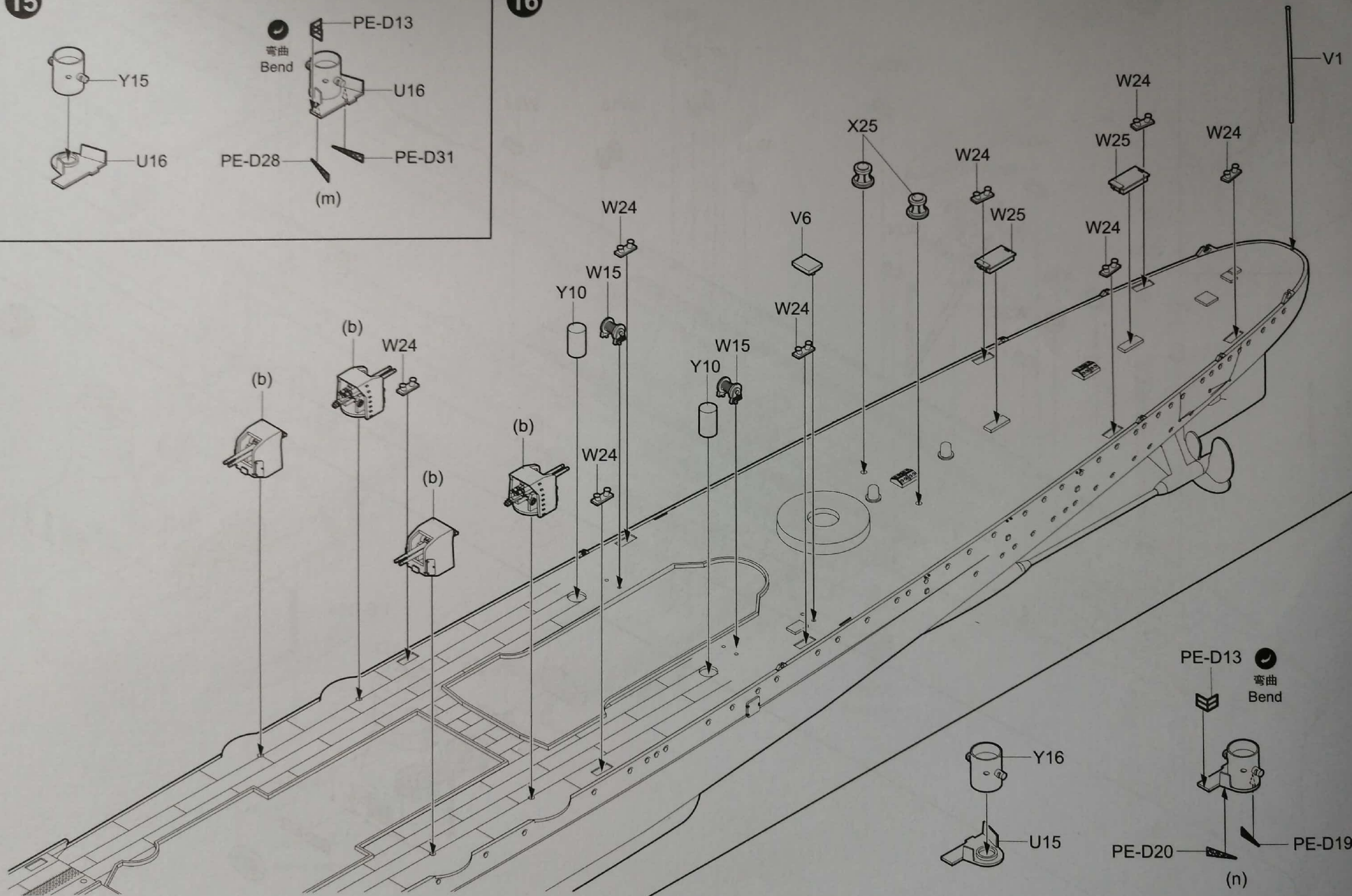

17

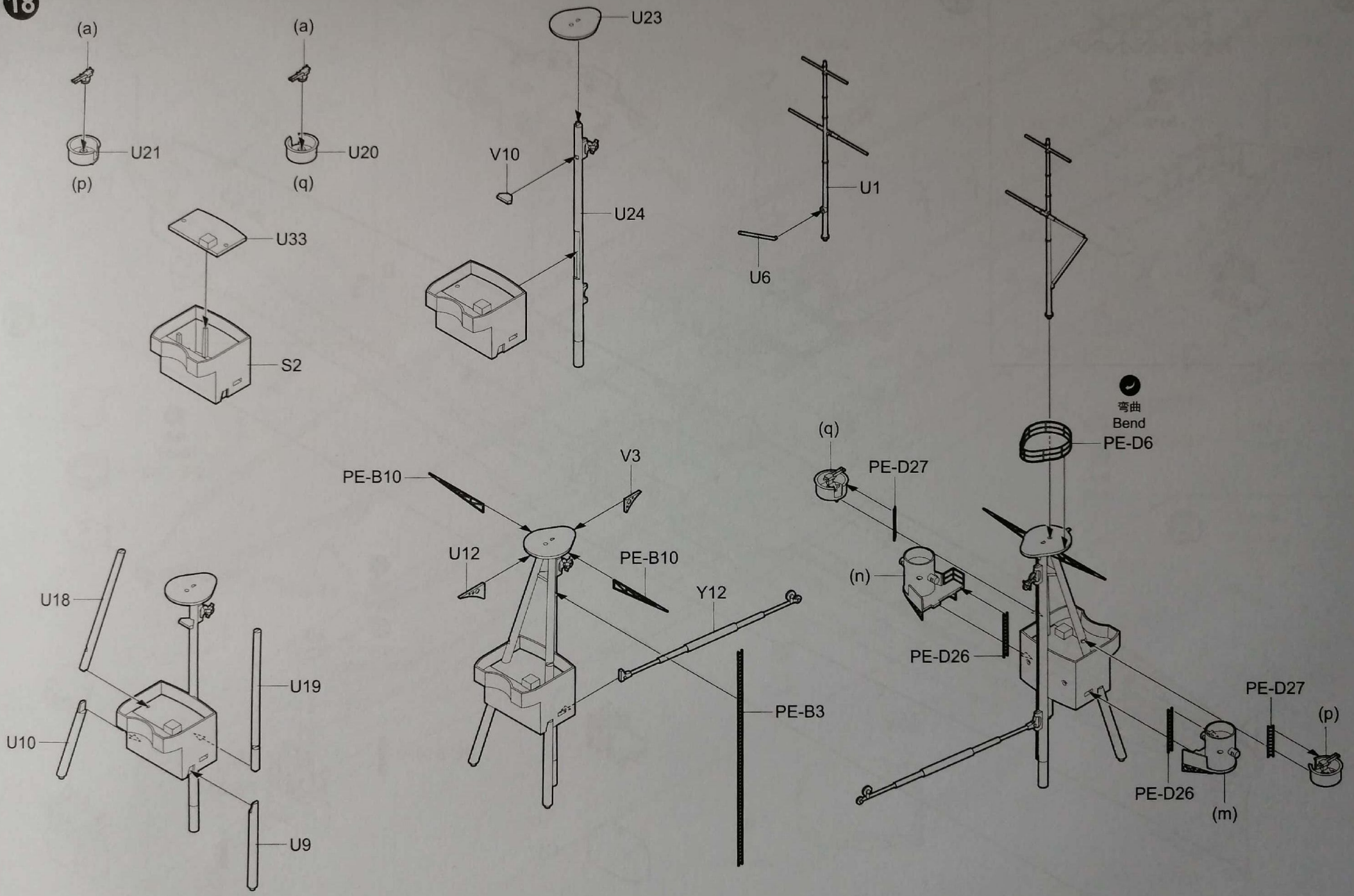

19

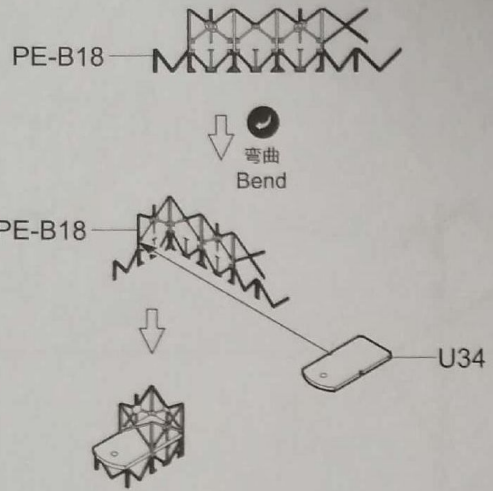

20

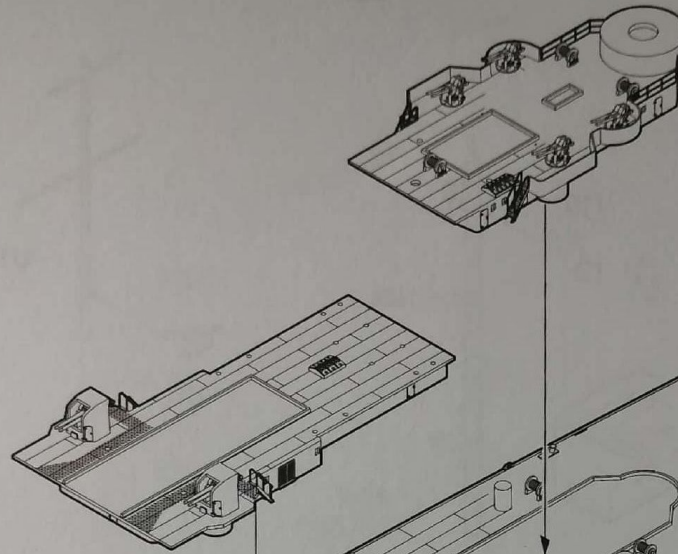

21

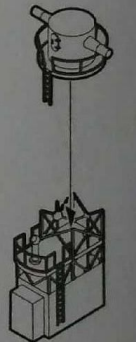
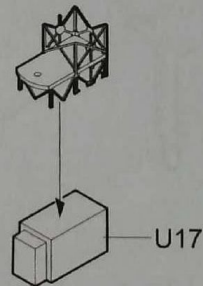
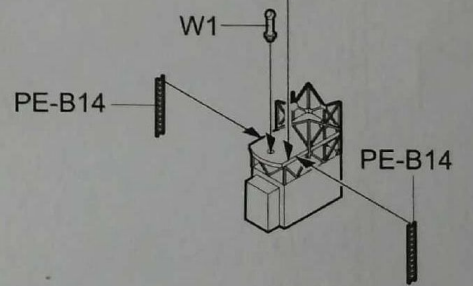

22

制作两组
Make two

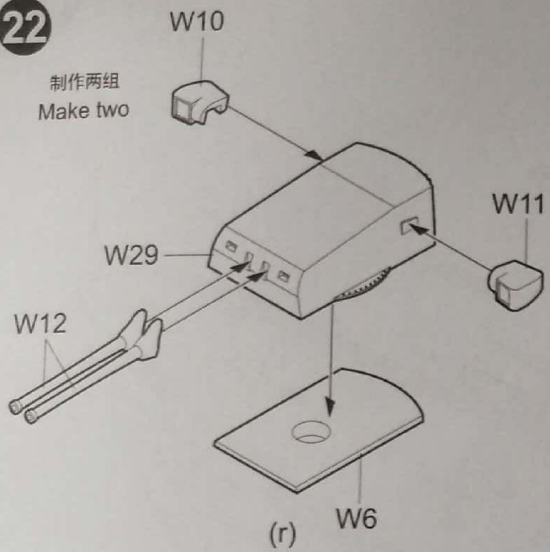

23

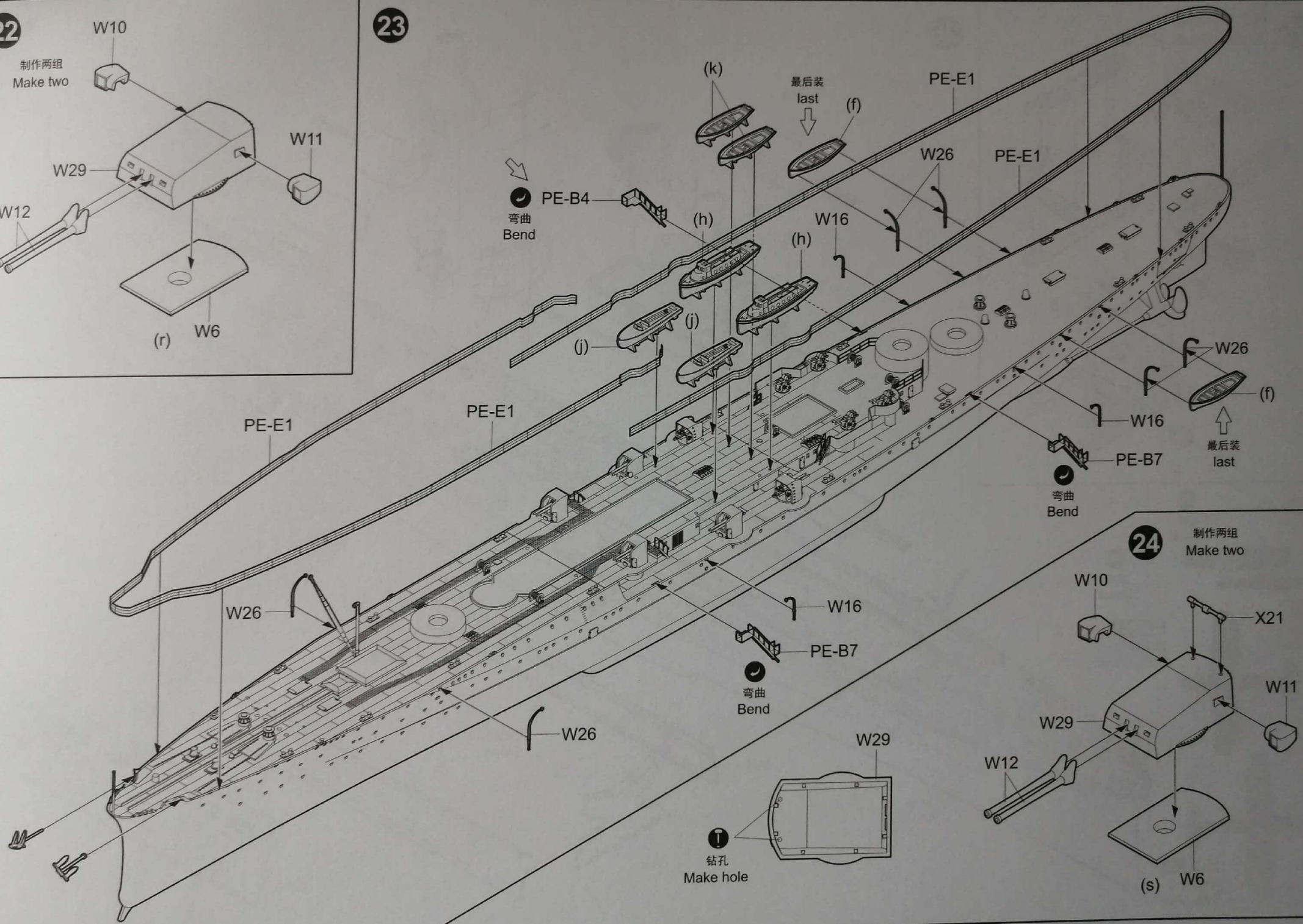

24

制作两组
Make two

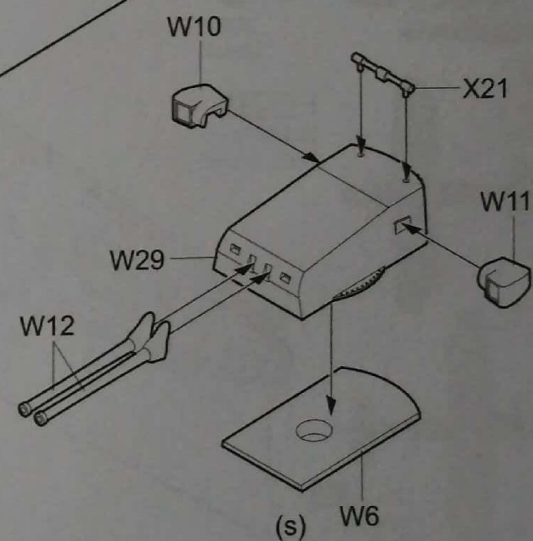

25

RO.43的组装
Assembly of RO.43

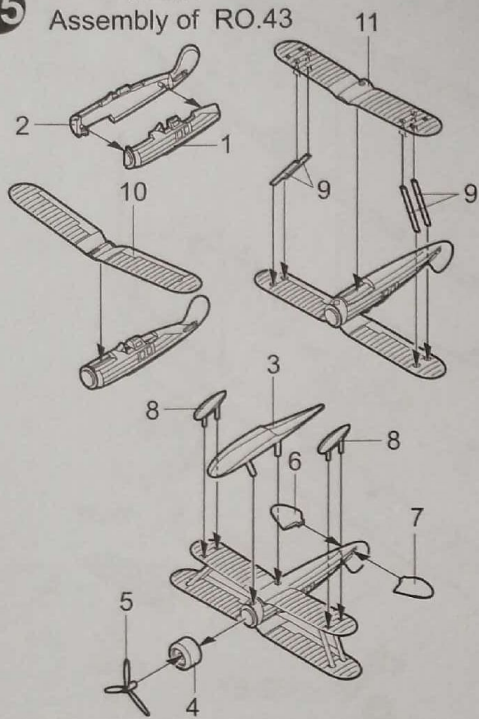

26

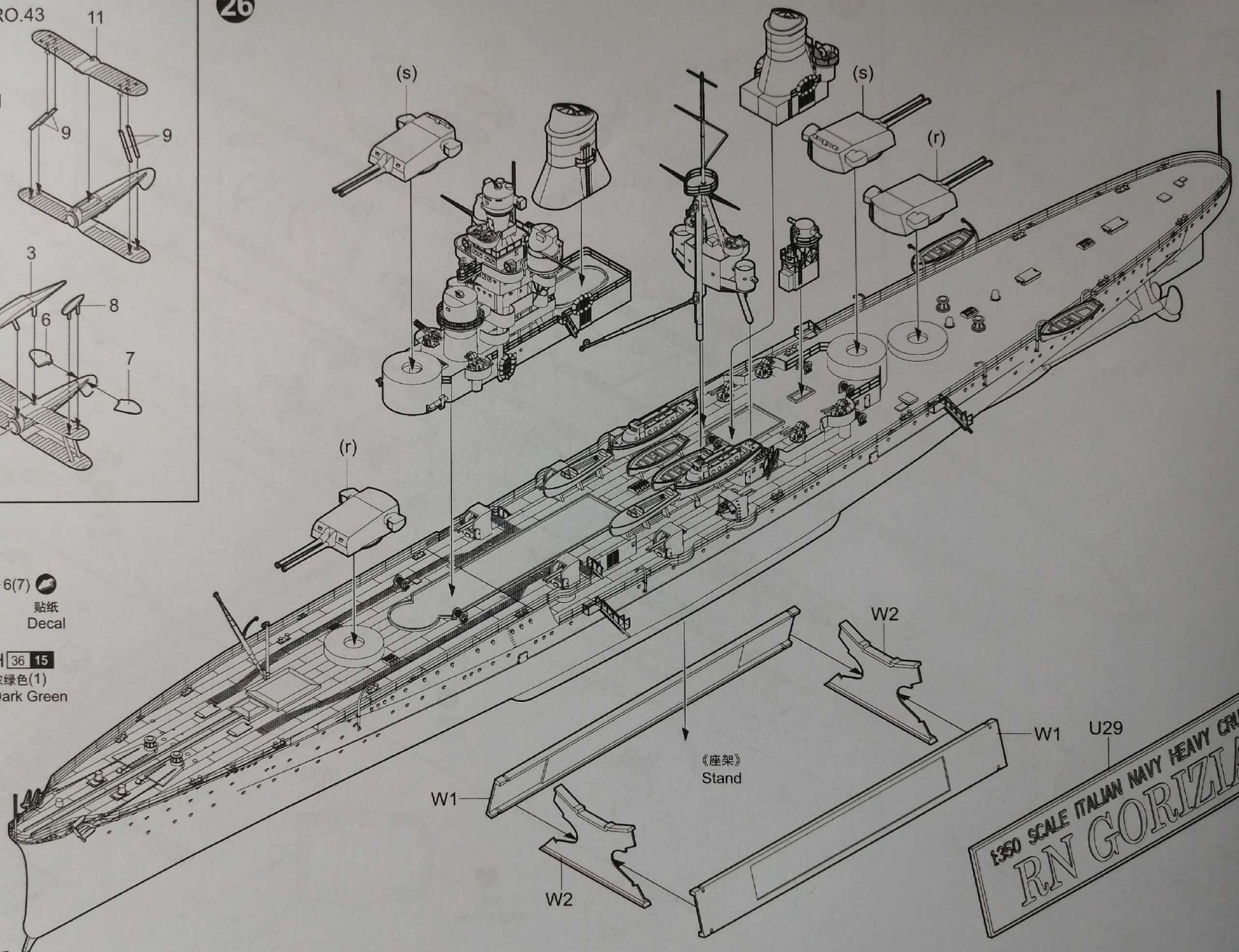

RO.43

4(5) 贴纸
Decal

6(7) 贴纸
Decal

贴纸 8
Decal

H 36 15
浓绿色(1)
Dark Green

贴纸 9
Decal

8

贴纸 9
Decal

H 36 15
浓绿色(1)
Dark Green

1/350 scale 05349

Italian Heavy Cruiser Gorizia



NEW VARIANT!



Gorizia in Otto Group Orlando shipyard started on March 17, 1930, launched on December 28, 1930, and be completed by December 23, 1931. Zara class heavy cruiser ship for number 3.

After the completion of Gorizia incorporated into the second cruiser detachments, December 31, 1934, transferred to the cruiser detachment. Thereafter until 1940, Italy entered the war, Gorizia has been in the squad. From 1936 to 1937 during the Spanish Civil War, Gorizia activities in Spanish waters. Gorizia in August and September 1941 to participate in intercept the British meat Action and the "Halberd action", at the same time cover the communication lines in North Africa in December 1941 and March 1942 were involved in the first times and second Siirt Bay naval battle. later, in June to participate in the intercept British army "Harpoon actions" and "strong action" involved in the intercept "bearing action" in August September 9, because the Italian government to Allied surrender while the Germans control. June 26, 1944, the United Kingdom and Italy combined commandos sneak into La Spezia and sunk her.

The kit consists of 335 parts on 20 sprue. 82 parts photo-etched.



Detailed 203mm Model 29 53cal main battery, 100mm secondary guns.

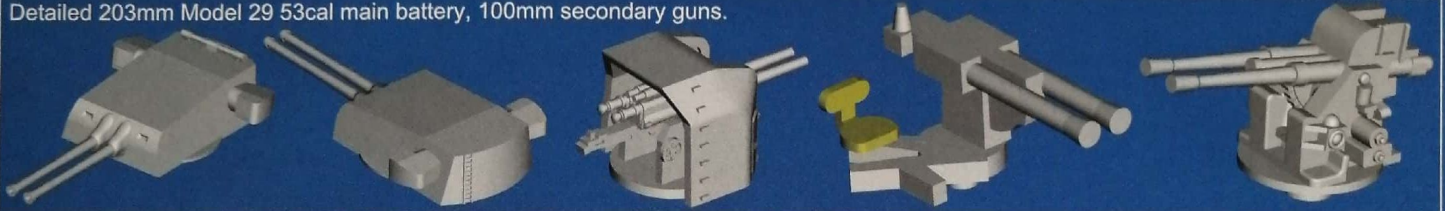

Citadel detailed with photo-etched parts.

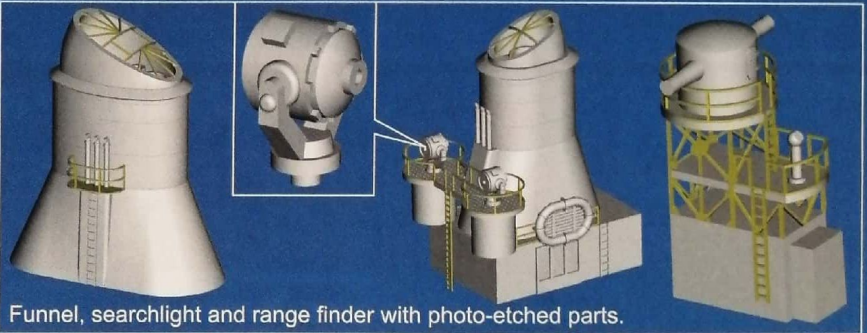
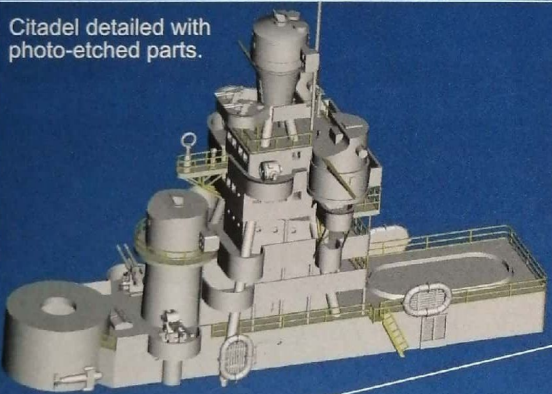

Funnel, searchlight and range finder with photo-etched parts.

Well-rendered propellers.

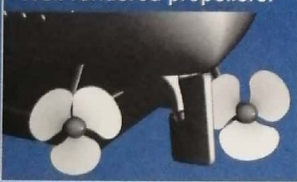

Details abound on the upper works of the ship.

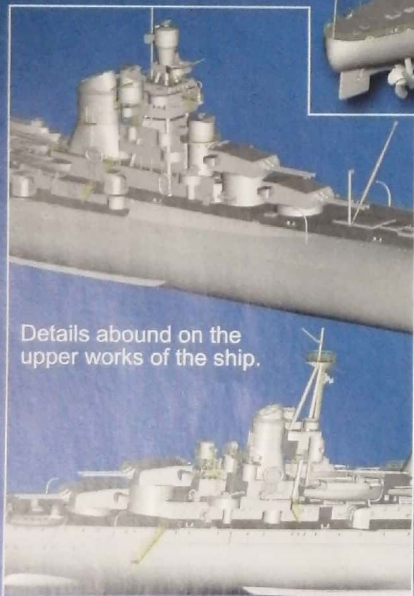

Photo-etched boarding ladder.



Separately molded, detailed anchor.



Separately molded captain's yacht, whaleboats and launch.



Trumpeter_Hobbyboss
 Trumpeter_Hobbyboss
 trumpeter&hobbyboss fan club
 小号手模型

同标贴指示
Painting & Marking guide

PAINT REFERENCE COLOR

Color	Mr.Hobby	Acrycion	Vallejo	Model Master	Tamiya	Humbrol	Color	Mr.Hobby	Acrycion	Vallejo	Model Master	Tamiya	Humbrol
Red 红色	H 3 3	N 3	908	1503	X7	19	Cocoa Brown 巧克力色	H 17 29	N 17	985	-	XF9	177
Yellow 黄色	H 4 4	N 4	953	1514	X8	69	Steel 黑铁色	H 18 28	N 18	864	1402	XF84	-
Green 绿色	H 6 6	N 6	969	2716	X5	3	Tan 黄褐色	H 27 44	N 27	981	-	-	9
Silver 银色	H 8 8	N 8	997	1546	X11	11	Navy Blue 深蓝色	H 54 14	N 54	898	-	-	77
Gold 金色	H 9 9	N 9	878	1744	X12	16	Rim70 Black Green 墨绿色	H 65 18	N 65	897	-	XF27	91
Flat White 消光白	H 11 62	N 11	951	1768	XF2	34	Gray 灰色	H 80 30 8	N 30 8	990	1728	XF19	127
Flat Black 消光黑	H 12 33	N 12	950	1749	XF1	33	Dark Seagrass 深海灰	H 83 33 3	N 83 3	994	-	XF50	123

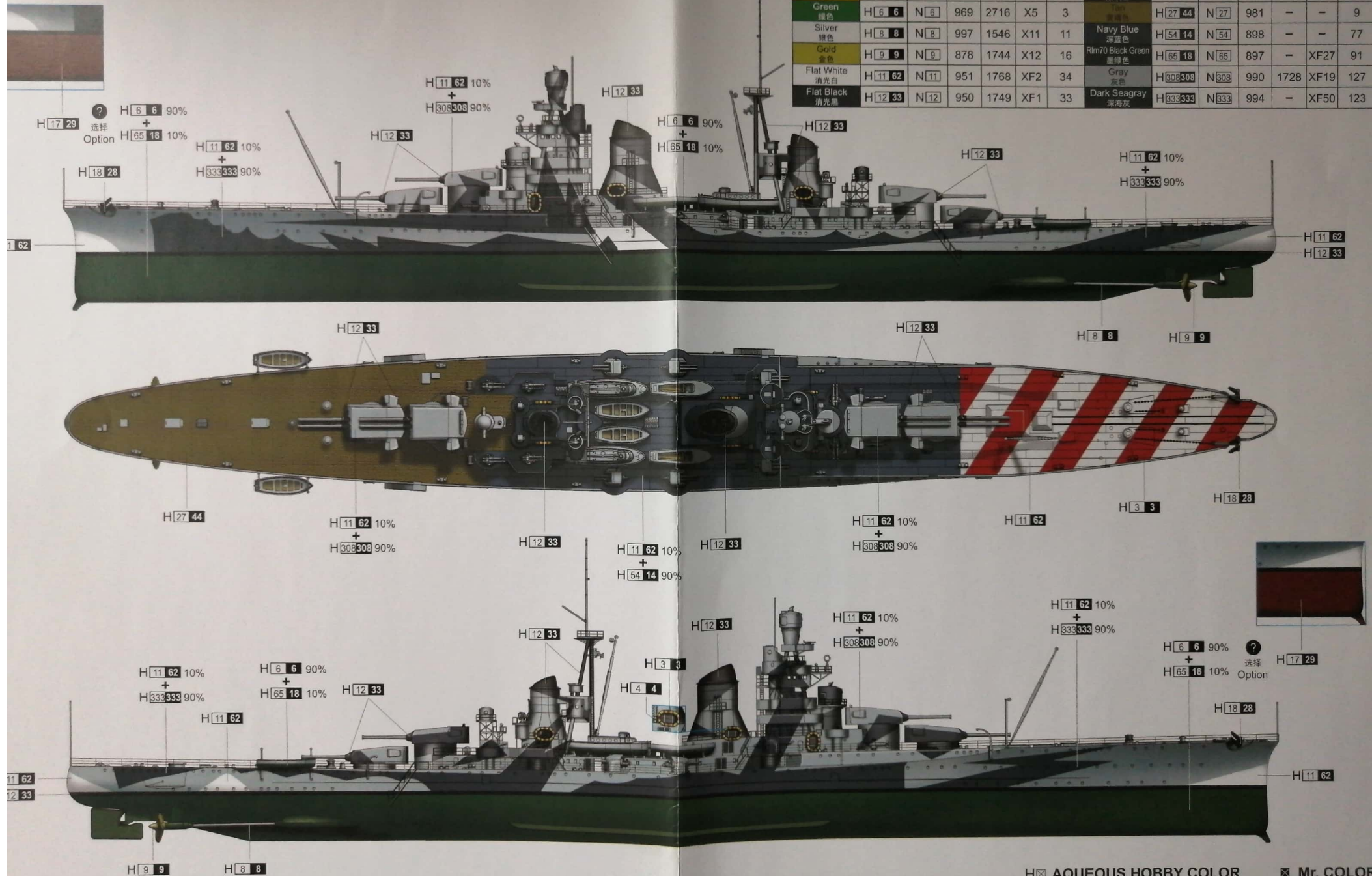

H AQUEOUS HOBBY COLOR Mr. COLOR