

JGSDF TYPE 87 AW

日本87式自行高炮

READ BEFORE ASSEMBLY:

- Study and understand these instructions thoroughly before beginning assembly
- When needed, remove photo-etch parts carefully using a modeling knife or photo etch sprue cutter, being careful not to damage or lose small parts.
- Take extra care in handling photo etch parts in order to avoid injury
- Apply instant cement sparingly to photo etch parts where instructed
- Tools recommended(not included in kit):Plastic and instant cements, sprue cutters,long nose pliers,modeling knife, small files, tweezers, pin vise & scissors. Soft cloth and sandpaper will also assist in construction
- Glue and paint are not included in the kit. Use plastic cement and hobby paints only. Color guide for purchasing paint is included in the kit.

装配之前仔细阅读

- 小心用模型锉刀锉平所有零件表面的注射浇口。
- 小心用刀片切下蚀刻片零件，不要遗失小零件。
- 用强力快干胶水粘合蚀刻片零件和金属轴。过量快干胶水使用可能导致可动零件会粘住，小心涂胶。
- 取蚀刻片时应特别注意安全，防止利边划伤手指。
- 某些零件表面需贴水贴纸，请选择在装配的同时进行。
- 推荐模型工具(自备)：胶水，水口剪刀，长咀钳，刀片，锉刀，镊子，钳，钻，剪刀，瞬间快干胶。
- 软布同砂纸同时也应该是必备工具。
- 请使用塑料胶水和油漆，模型内不含。



配重
Weight



使用强力胶
Cyanoacrylate glue



钻孔
Make hole



切除
Cut / Remove



贴纸
Decal



锉平
File / Sand



选择
Option



不涂胶水
No cement



弯曲
Bend

水贴纸的使用:

- 1.从水贴纸上剪下印花;
- 2.将印花放入温水中浸10秒, 然后放在干净布上。
- 3.拿着印花纸板将印花移到模型上;
- 4.手指蘸水将印花移到适当的位置;
- 5.用软布轻压印花直至水干, 气泡消失

DECAL APPLICATION

- 1.Cut decals from sheet as needed
- 2.Dip the decal in warm water for about 10 seconds and then place on soft clean cloth.
- 3.Hold the decal backing sheet edge and gently slide the decal onto the model in its proper position.
- 4.While still wet,decal can be adjusted for better fit on model by dampening it gently with your finger.
- 5.When placed in the proper position,gently press decal down with a soft cloth until excess water and air bubbles are gone.
- 6.Allow decal to dry completely before handling model

部品图 Parts

115233

A X4

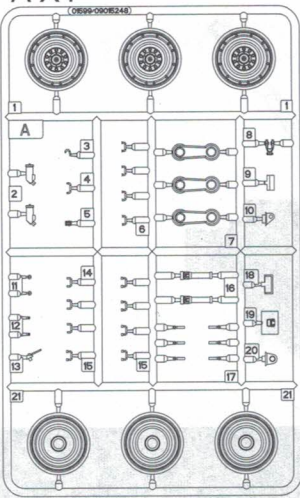

B X2

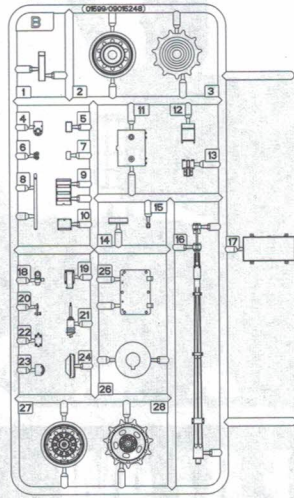

D

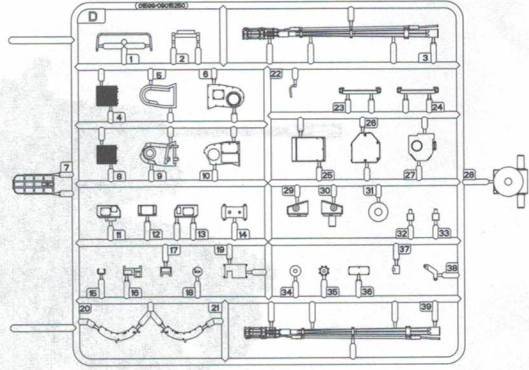

<<车底>>
Lower hull

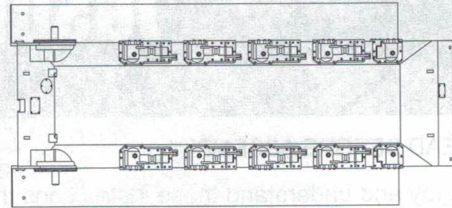

<<车面>>
Upper hull

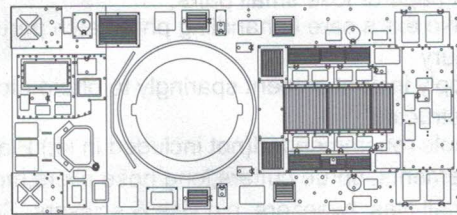

C

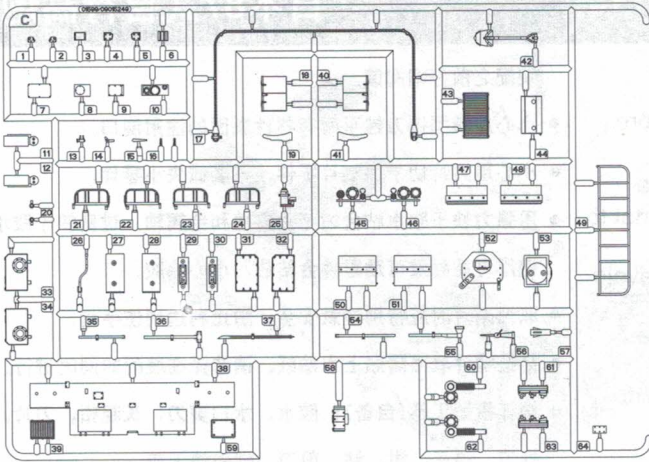

E

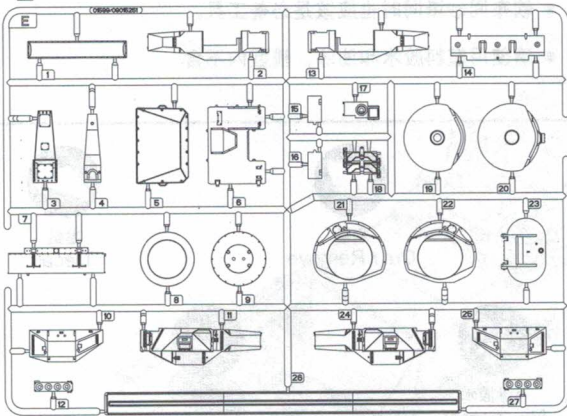

<<炮塔面>>
Top turret

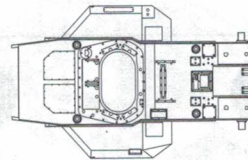

<<炮塔底>>
Bottom turret

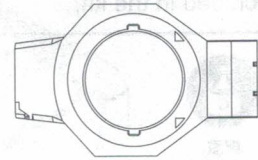

GP

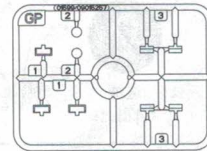

<<铜管>> X2
Copper duct
∅2.0X17.5mm



PE

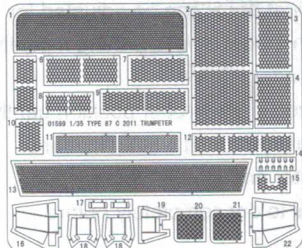

T X17

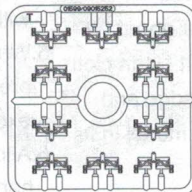

聚乙烯套
Poly cap

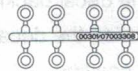

<<水贴>>
Decal



01599

1

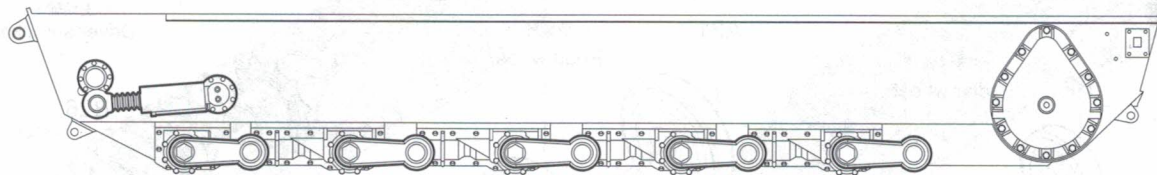

②
选择
Option
<<行驶状态>>
Drive state

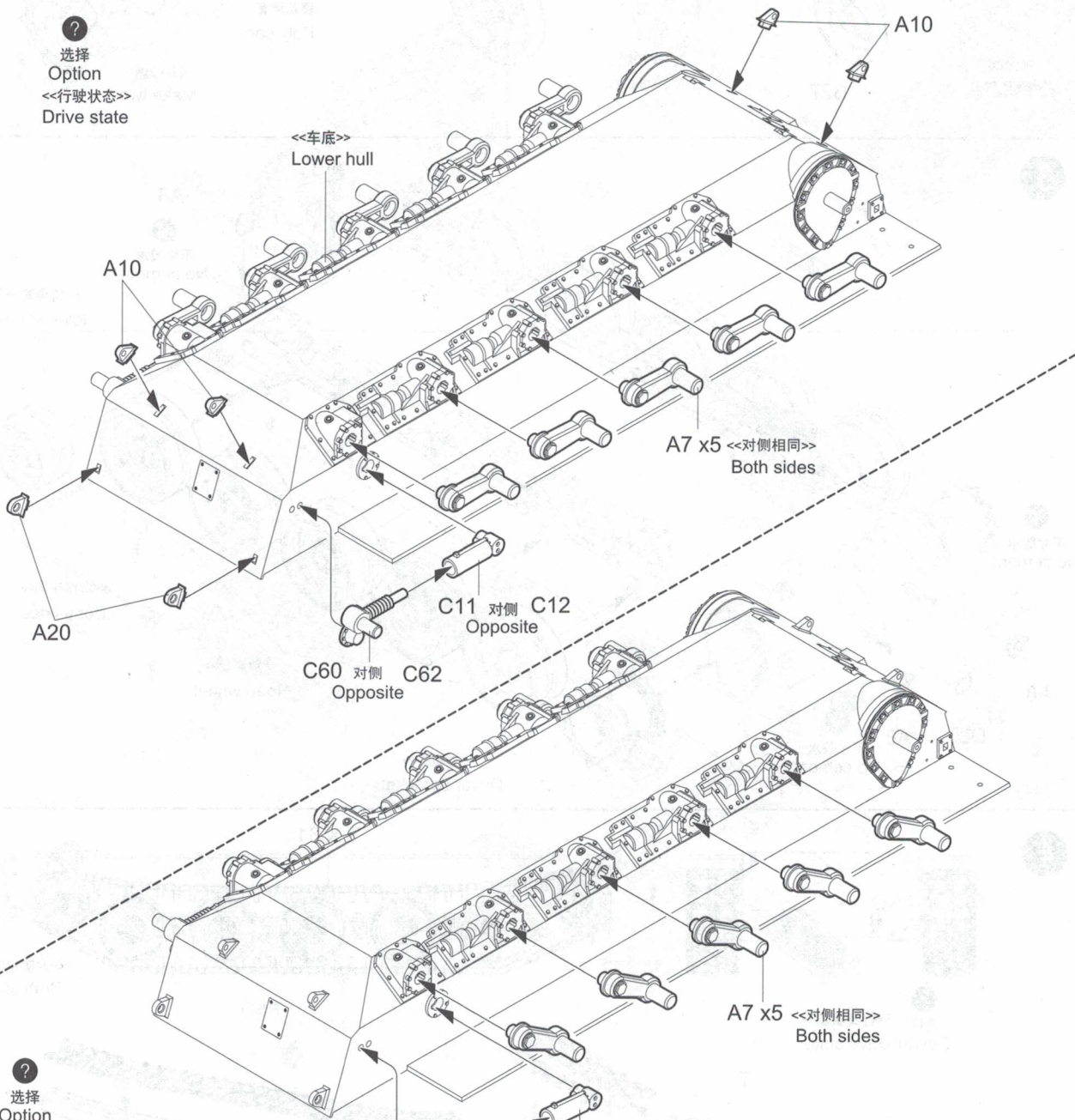

③
选择
Option
<<静止状态>>
Hold still state

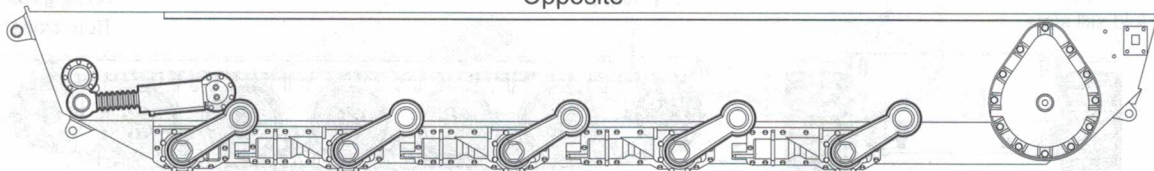
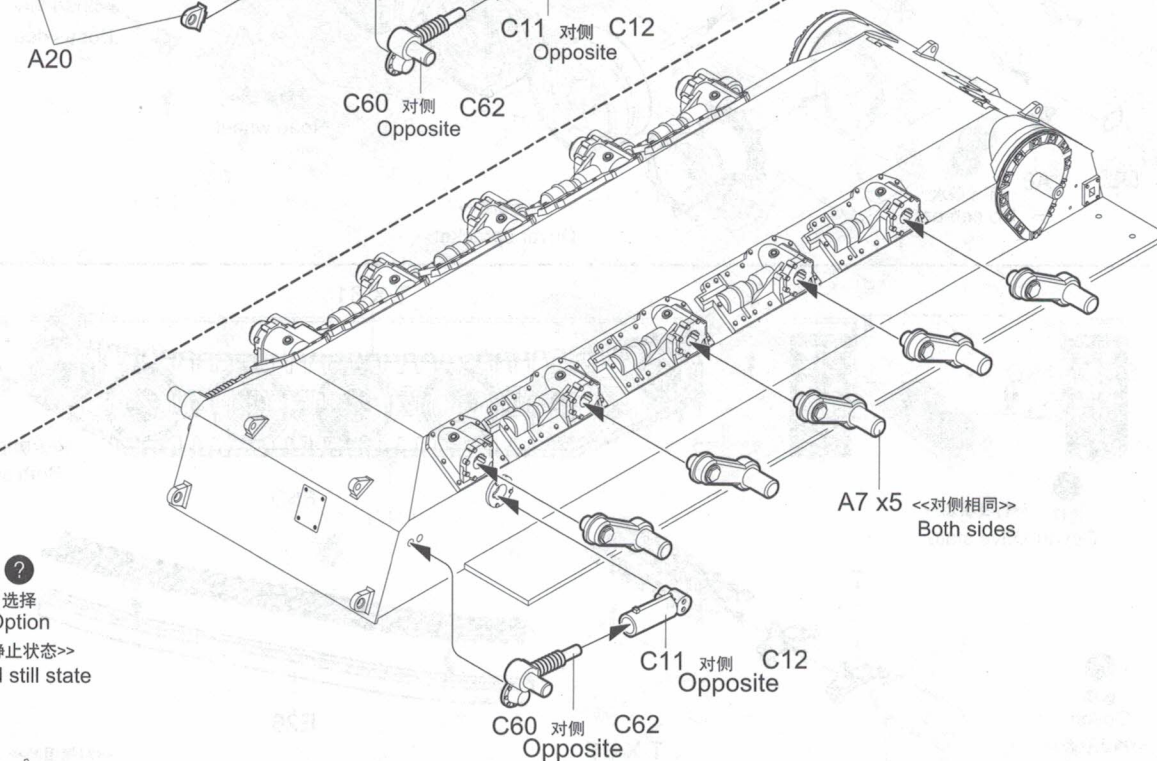

2

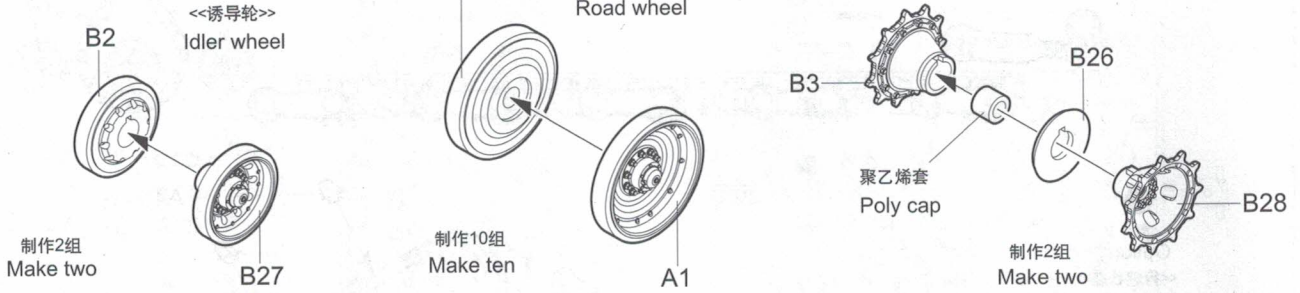

3

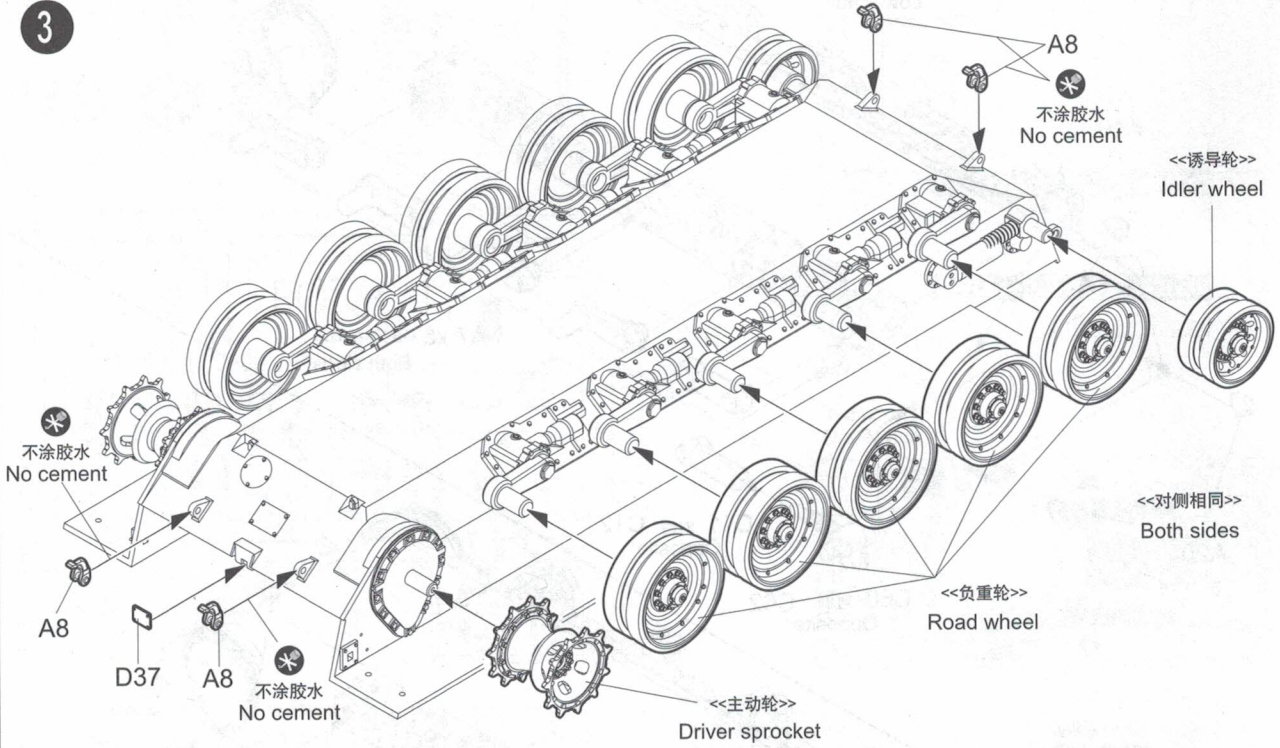

4

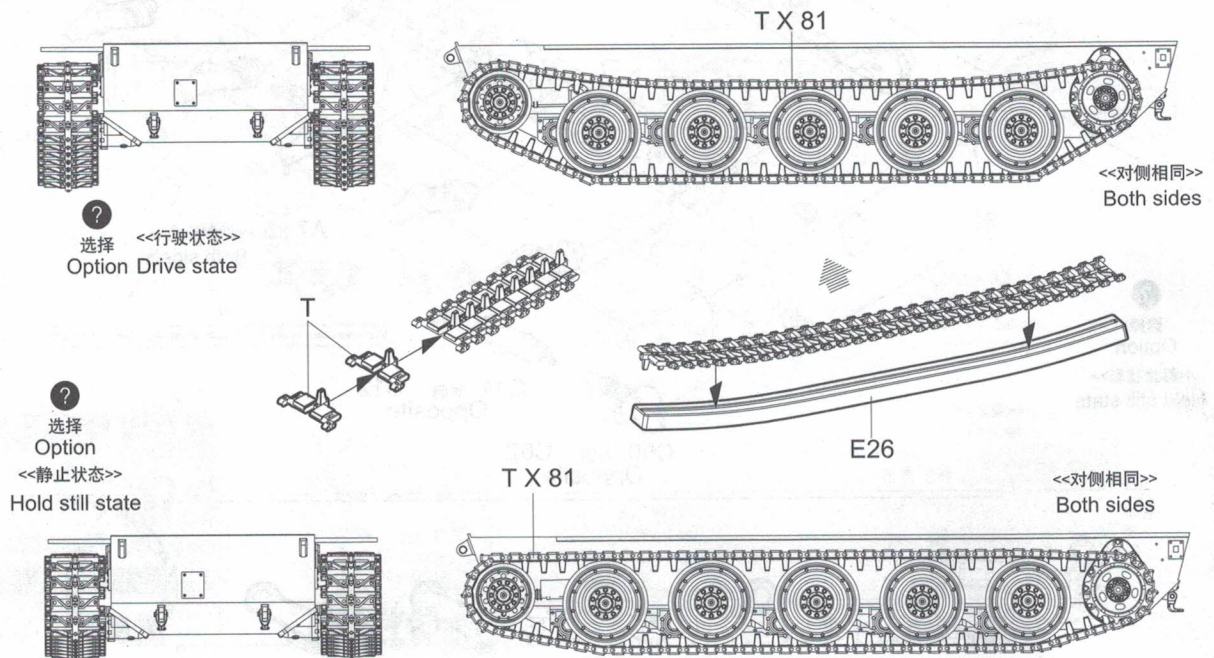

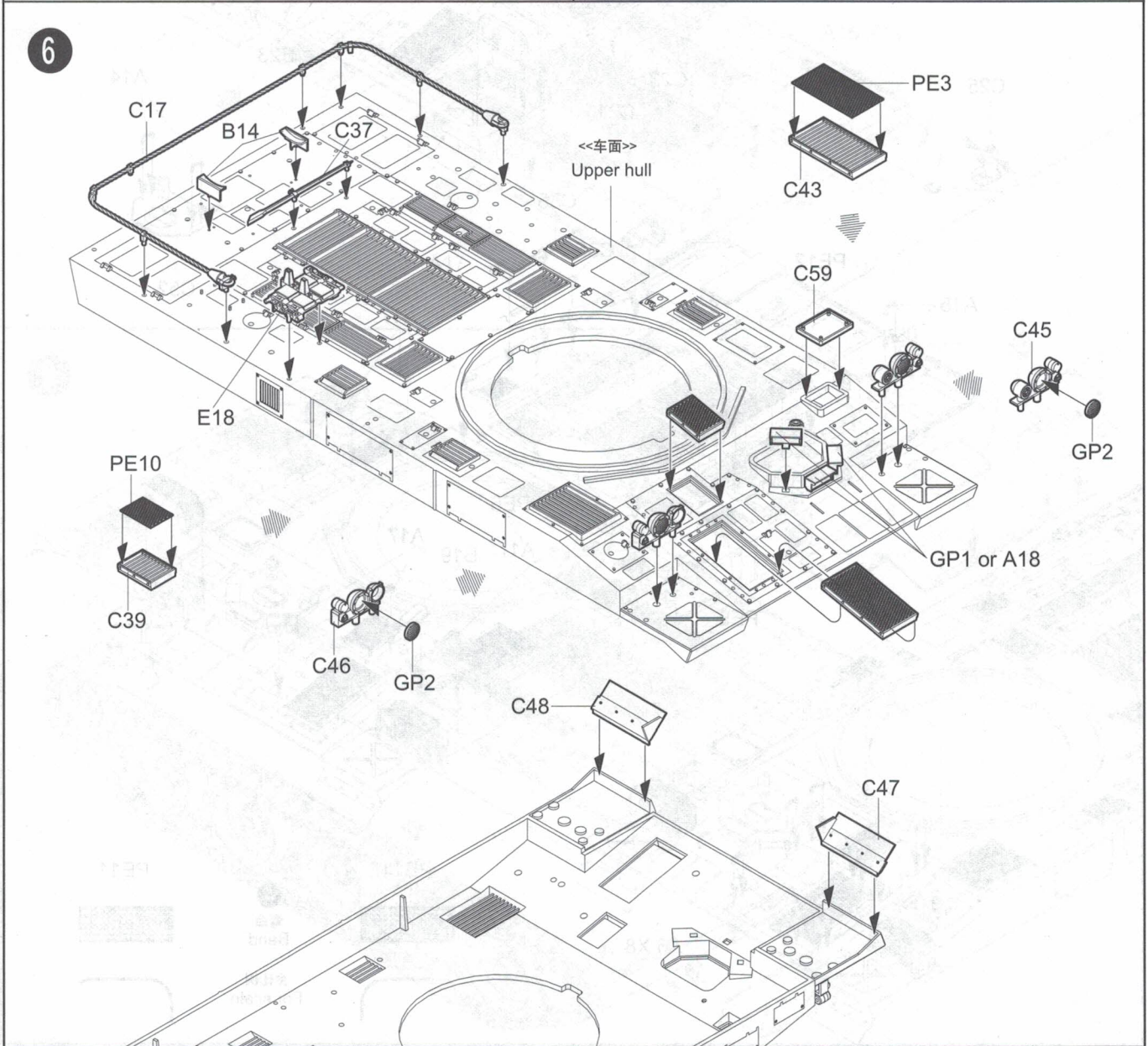
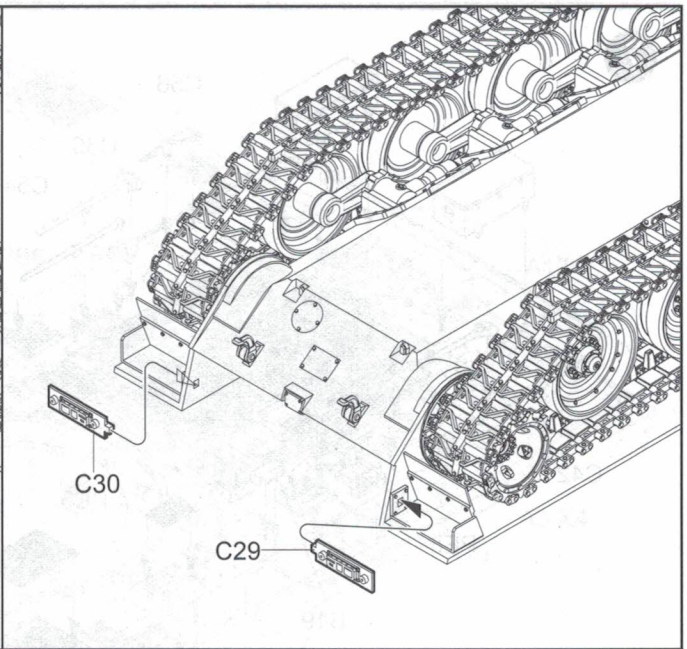
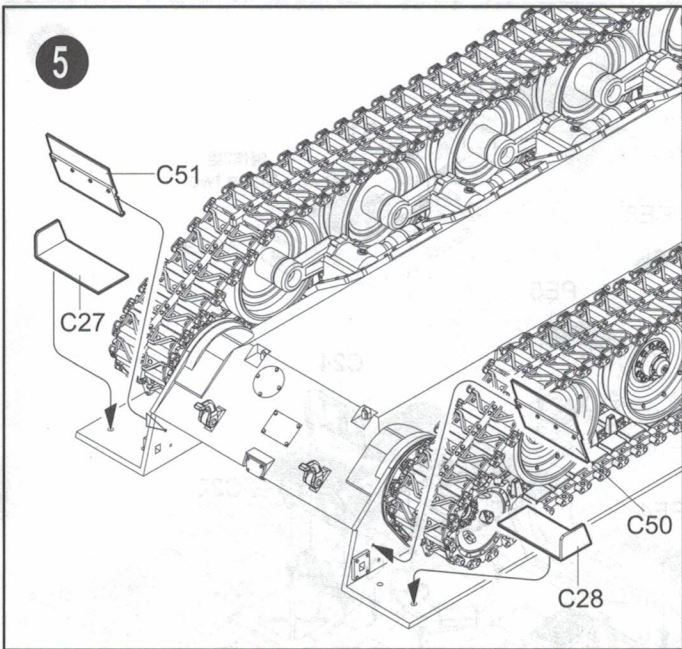

7

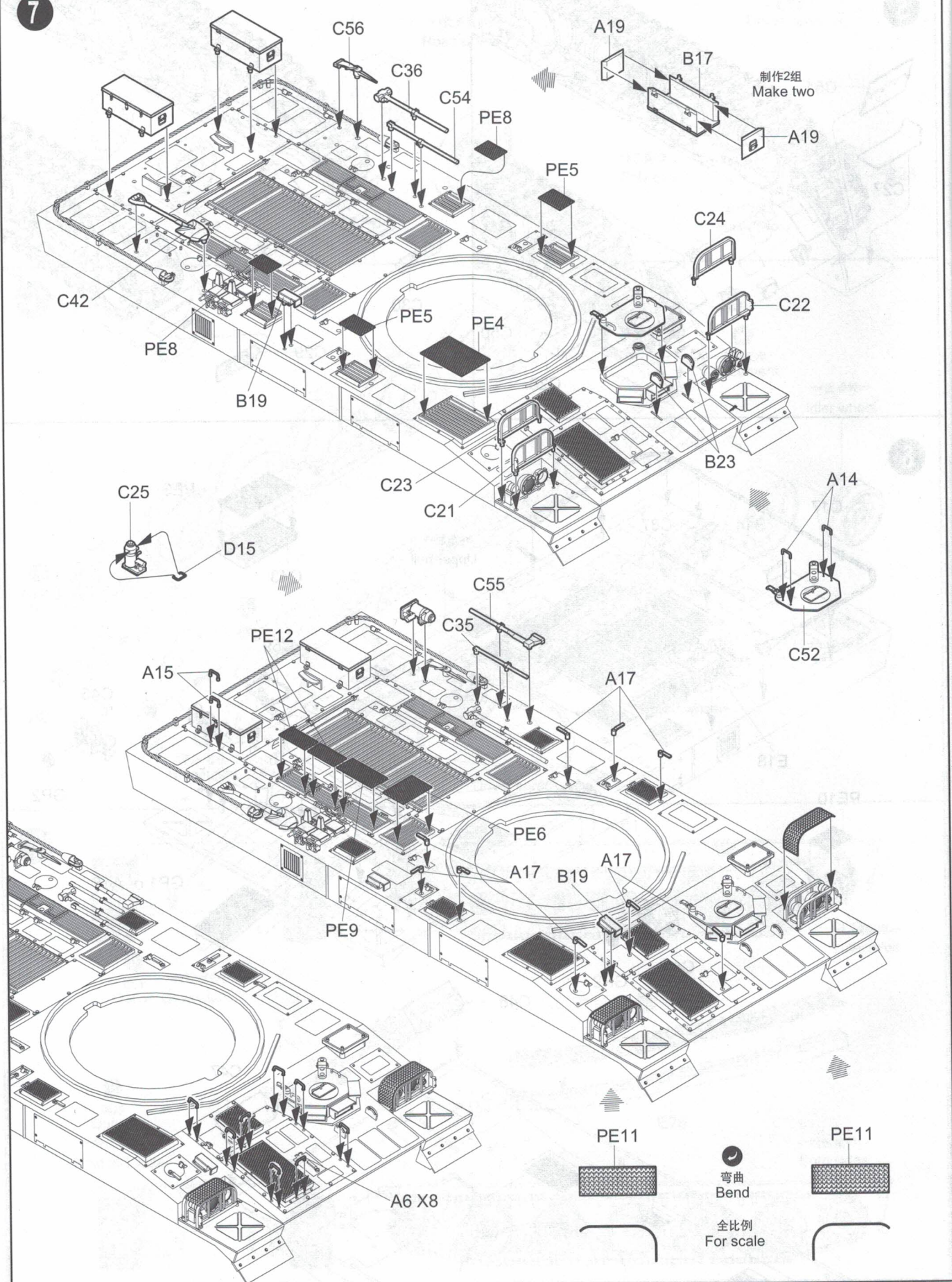

8

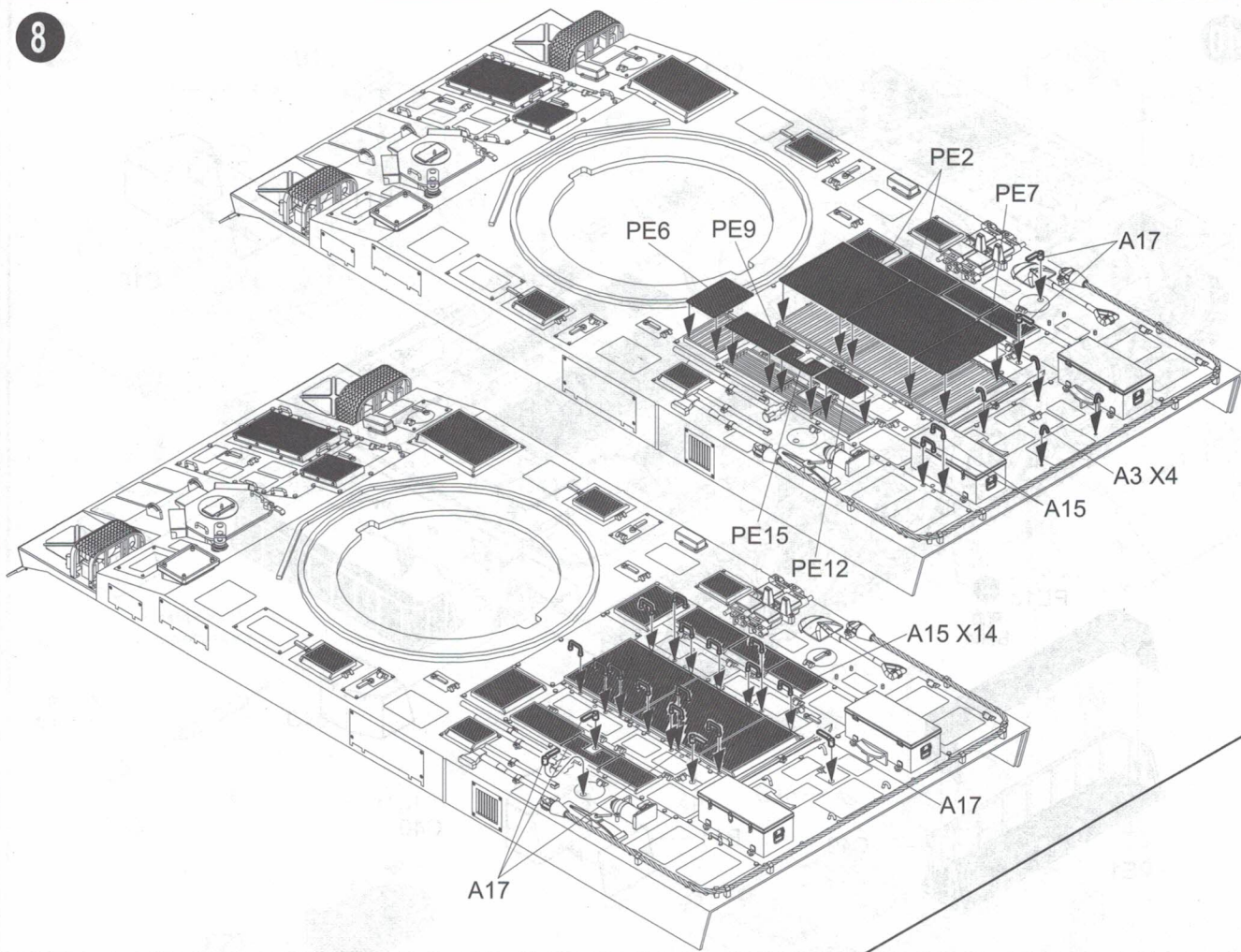

9

制作2组
Make two

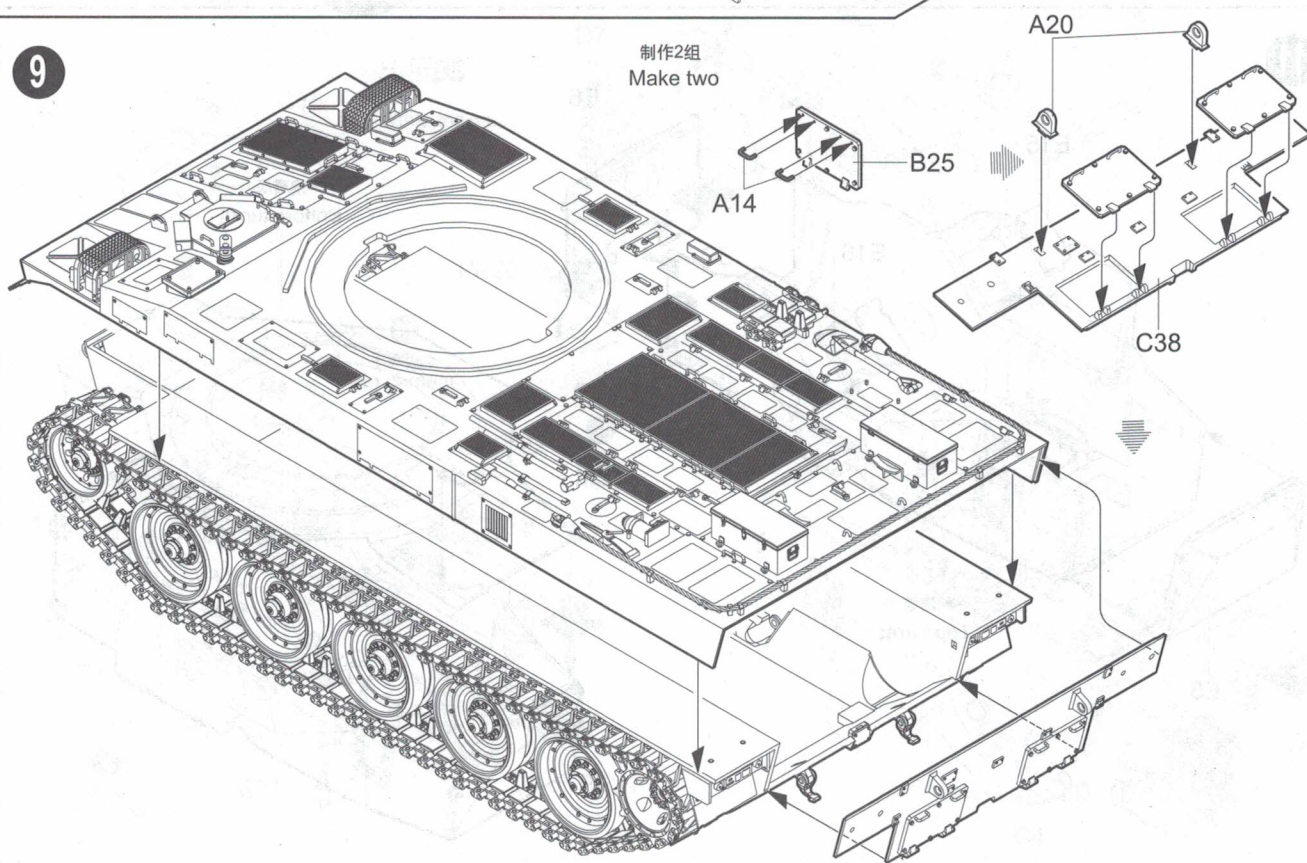

10

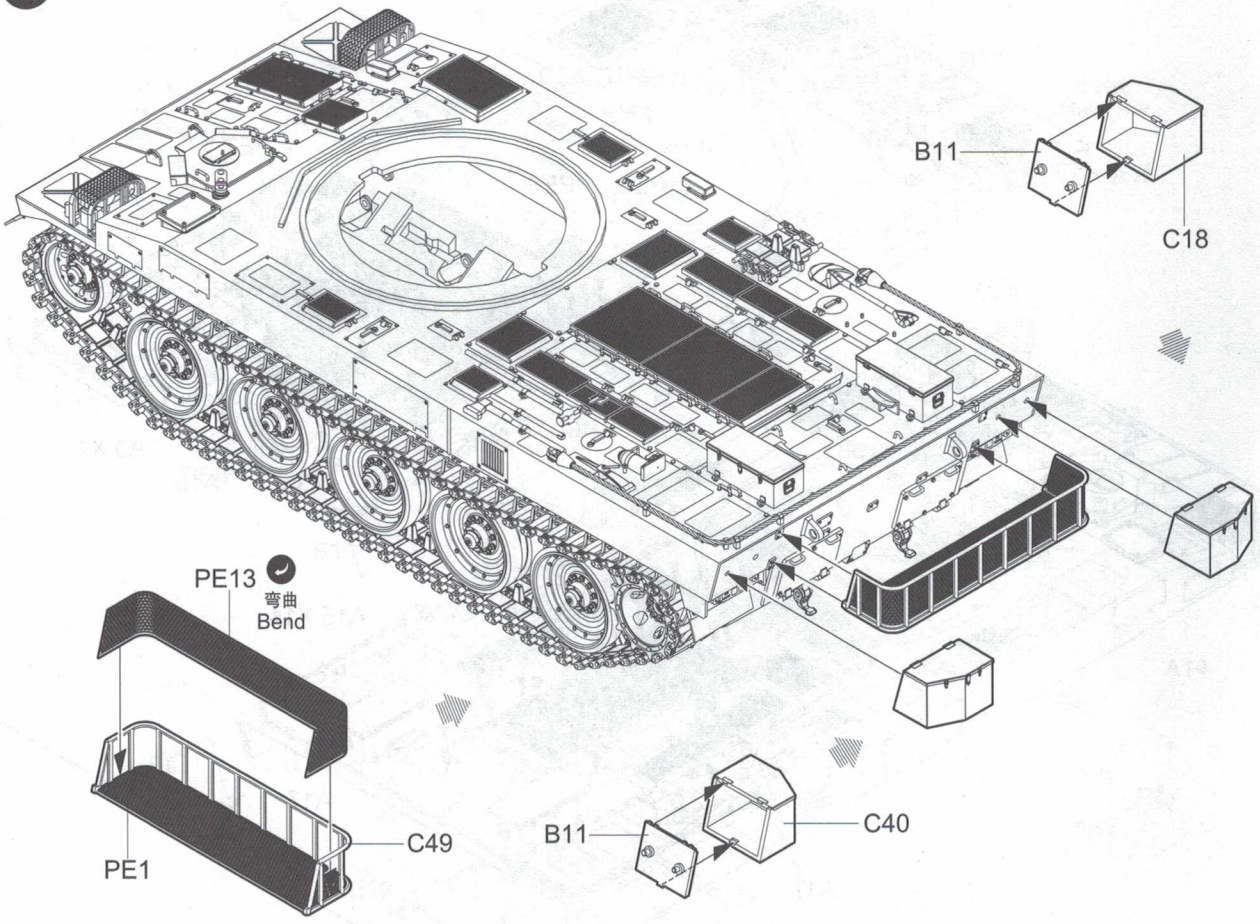

11

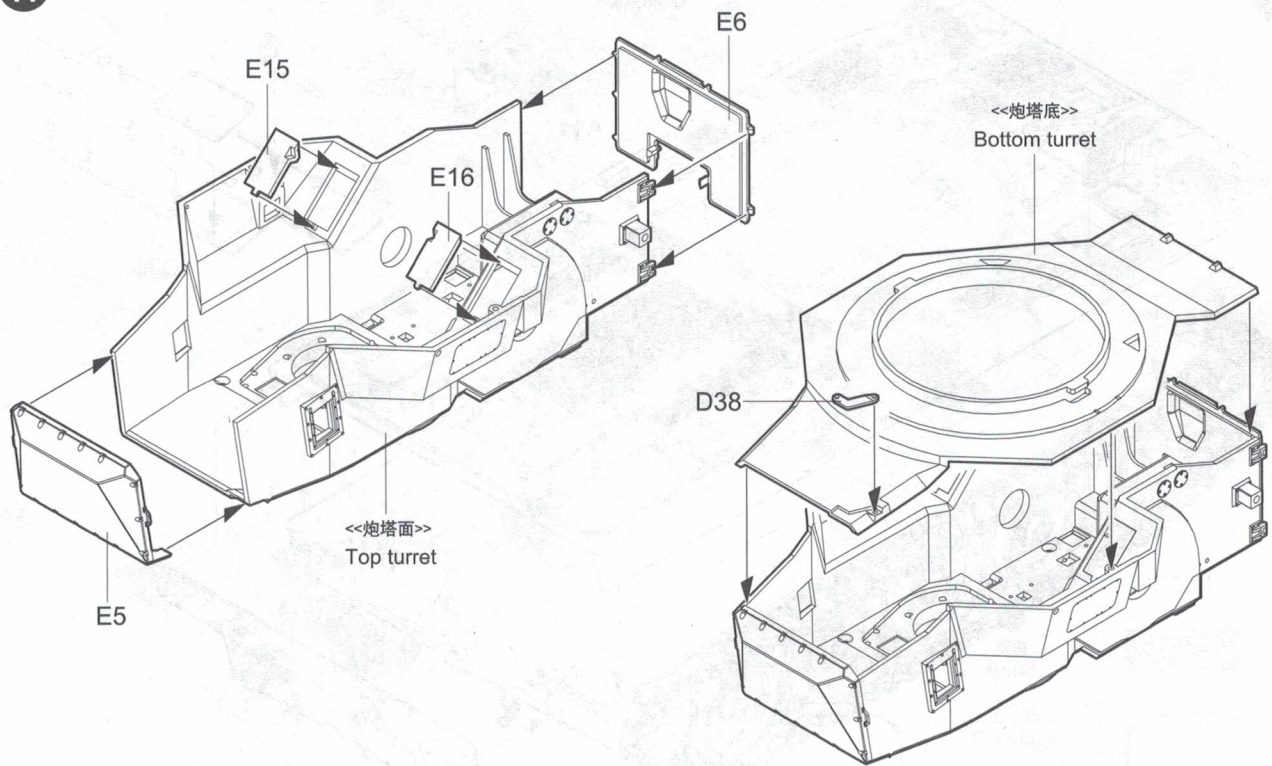

12

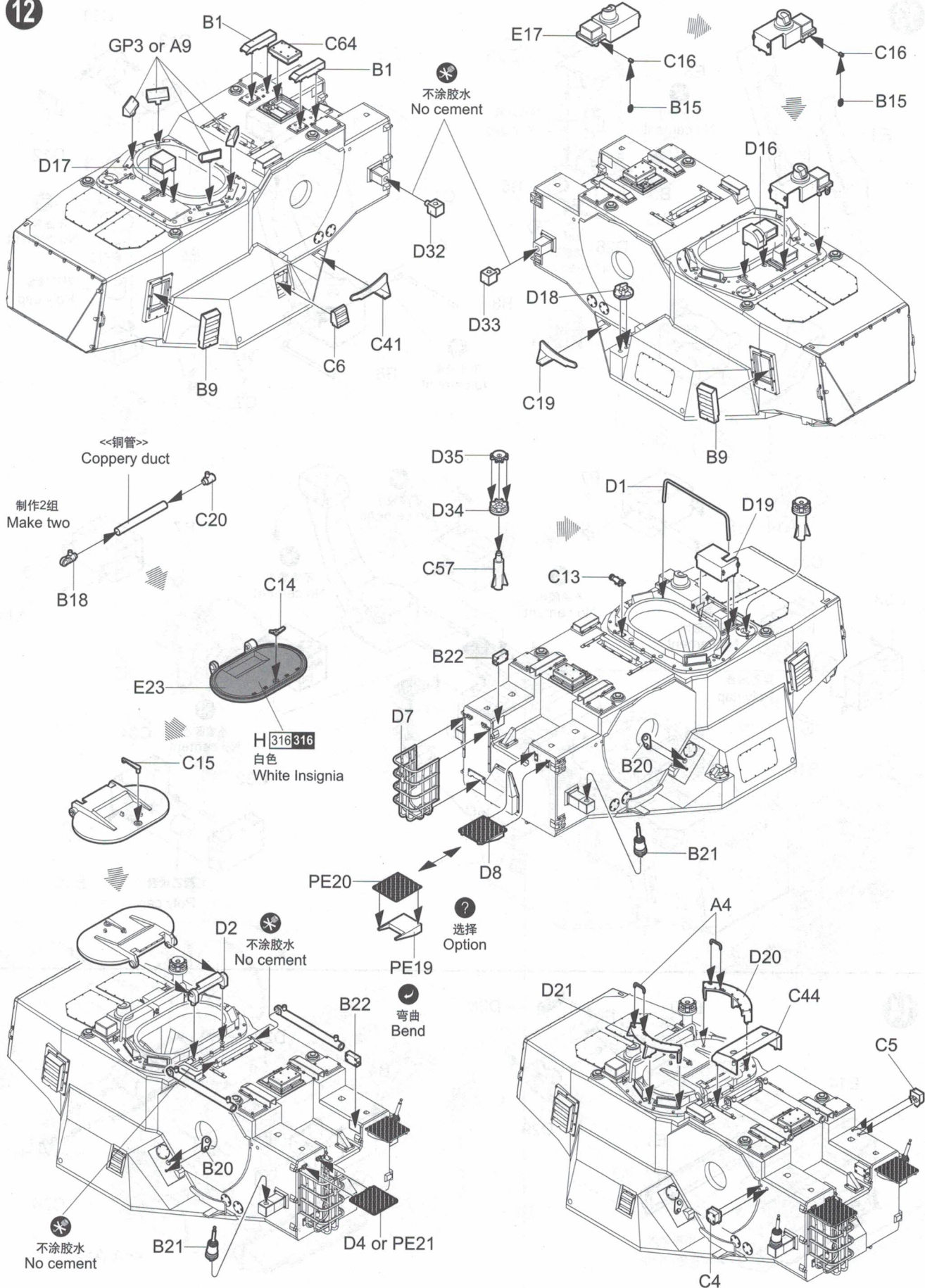

13

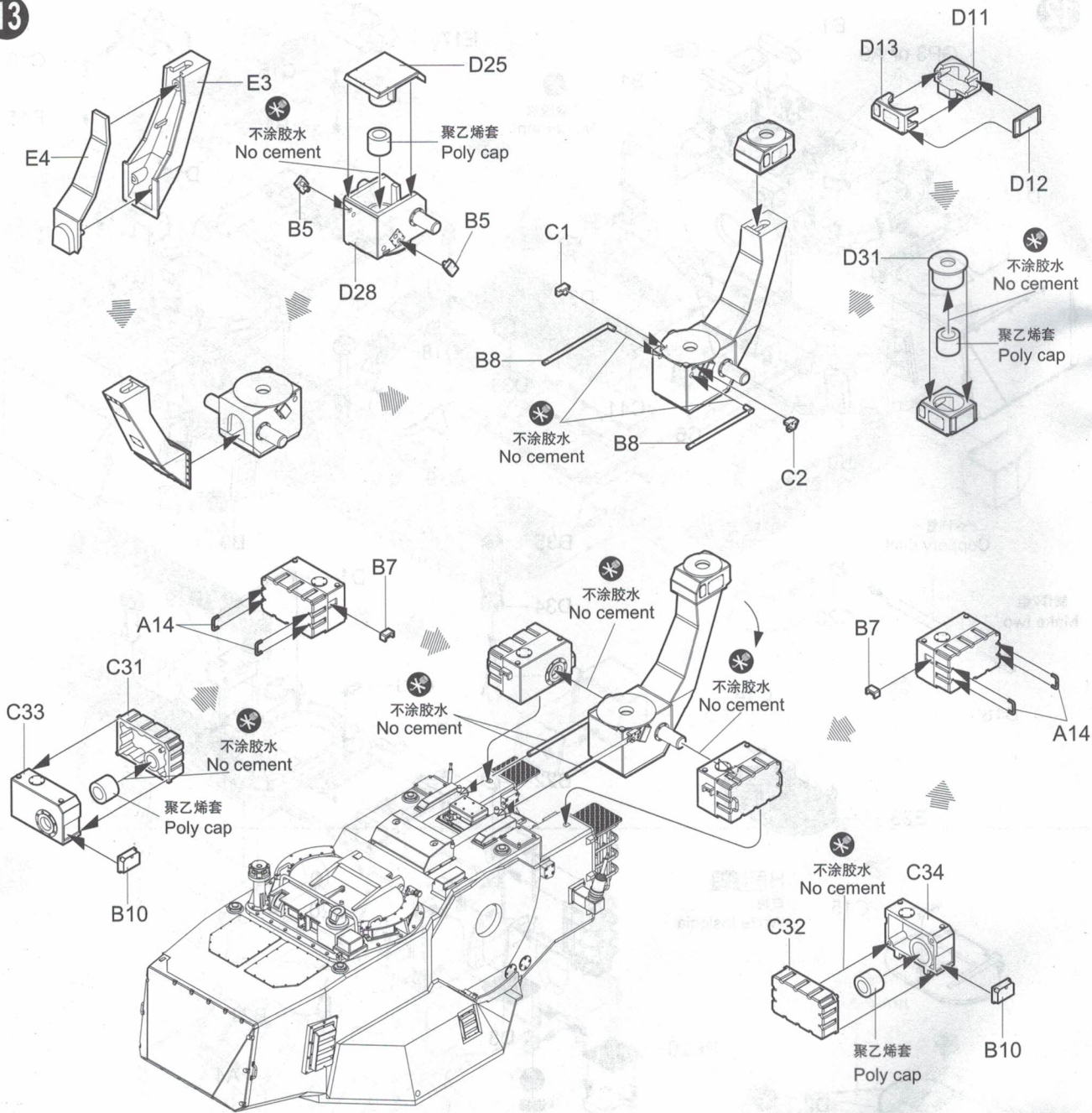

14

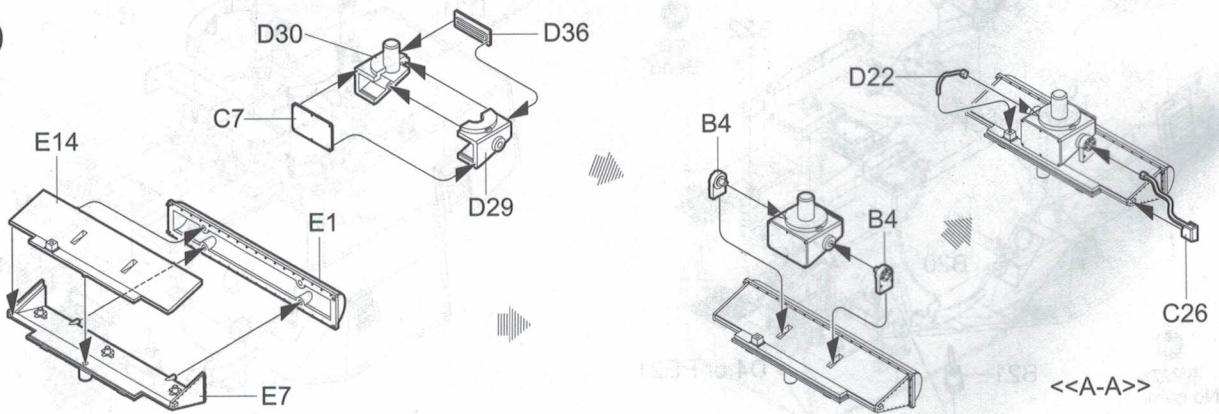

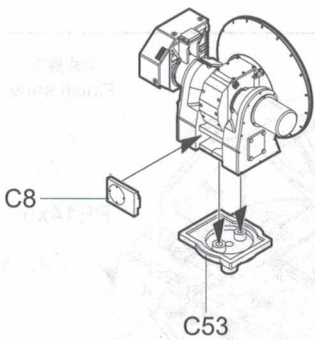
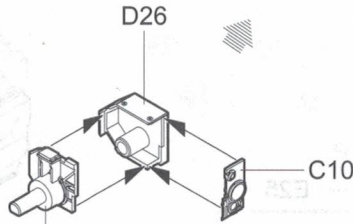
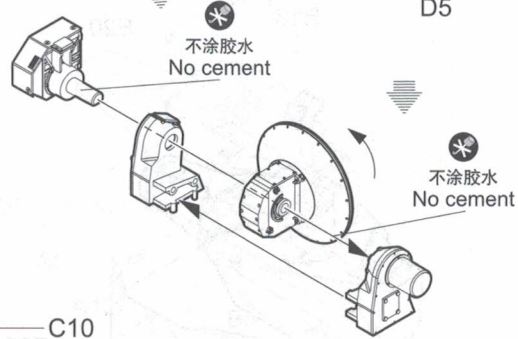
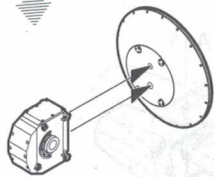
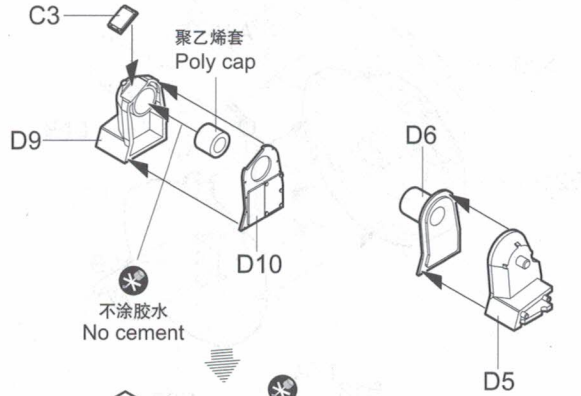
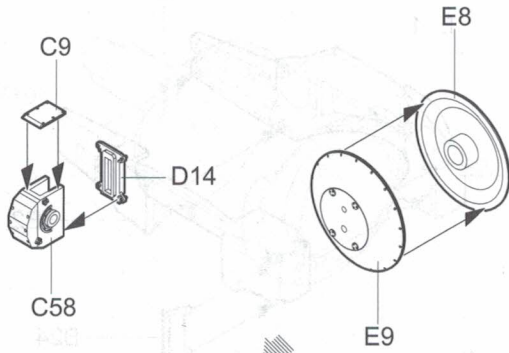

D27

打开展示
Open show

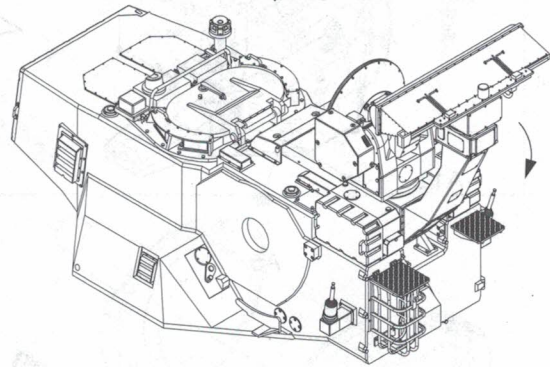

<<A-A>>

不涂胶水
No cement

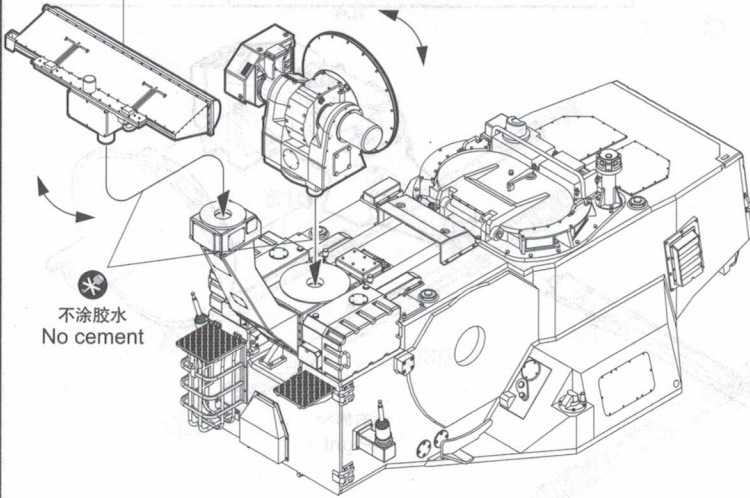

关闭展示
Close up show

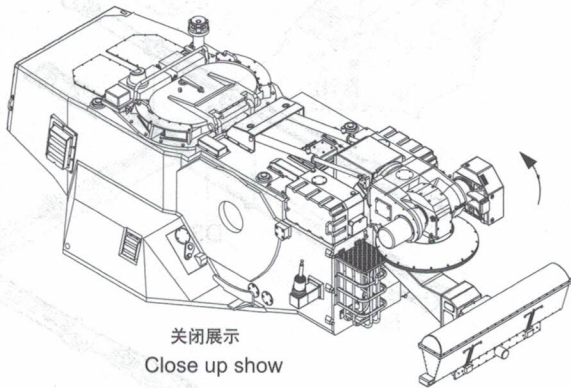

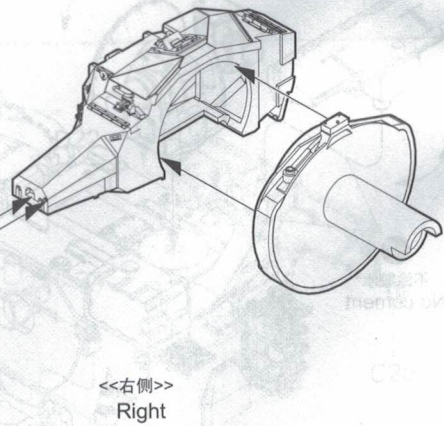
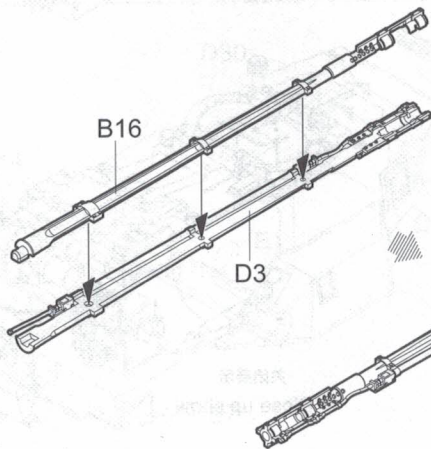
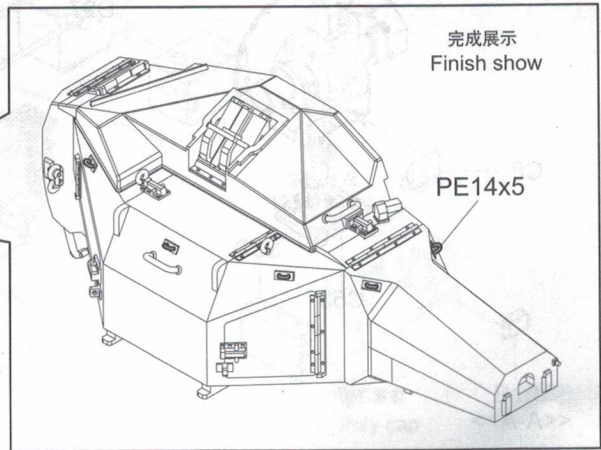
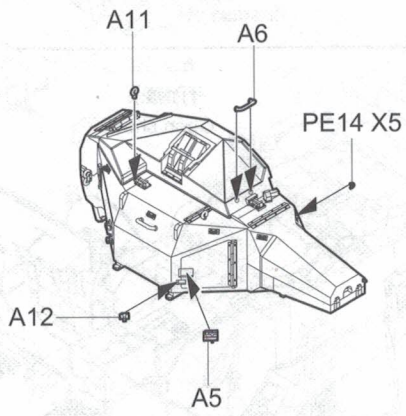
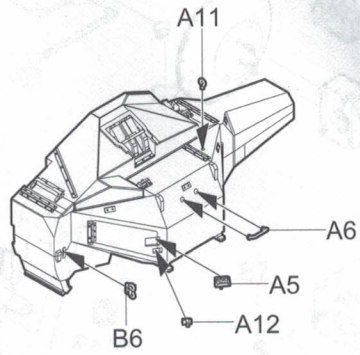
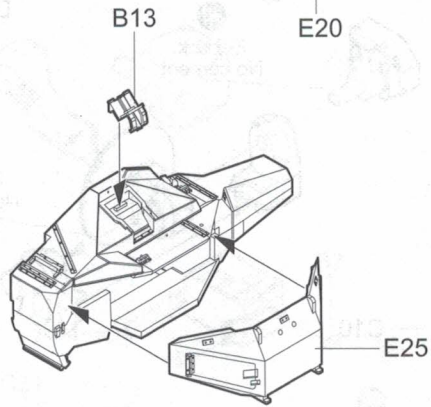
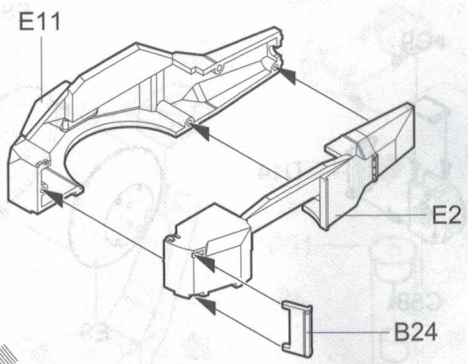
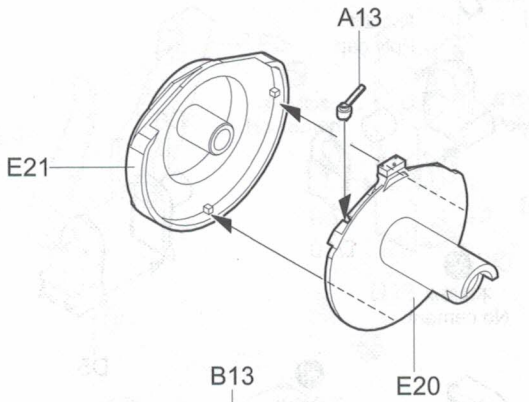

17

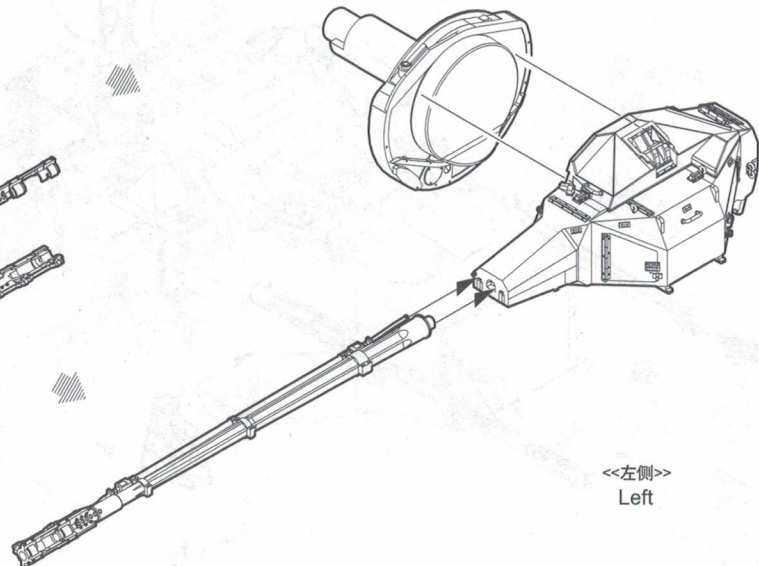
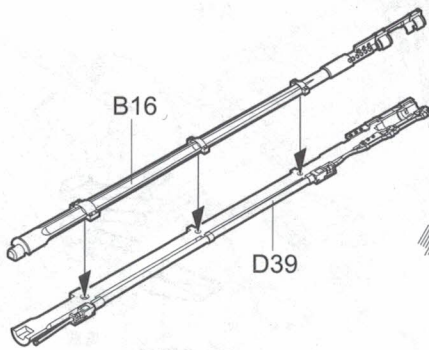
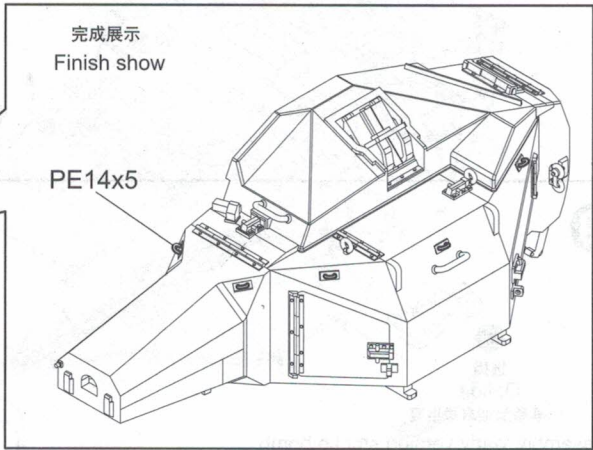
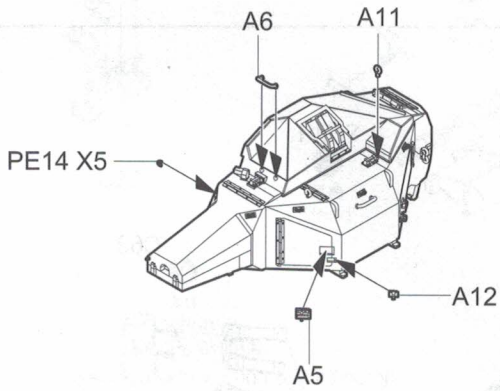
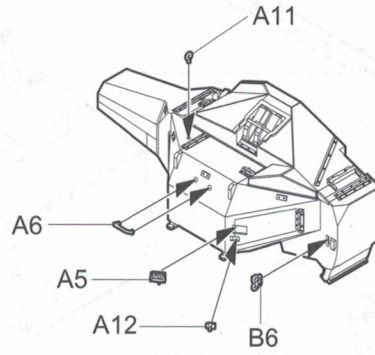
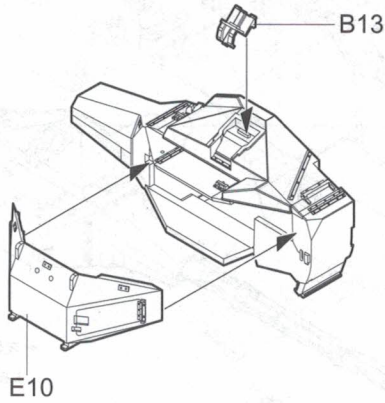
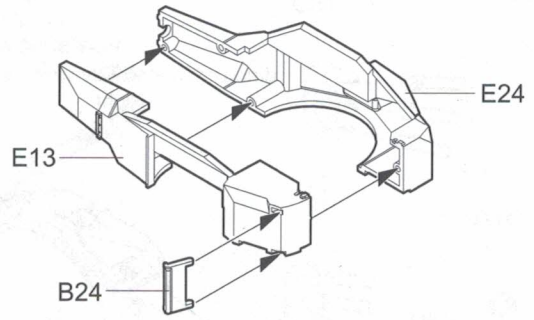
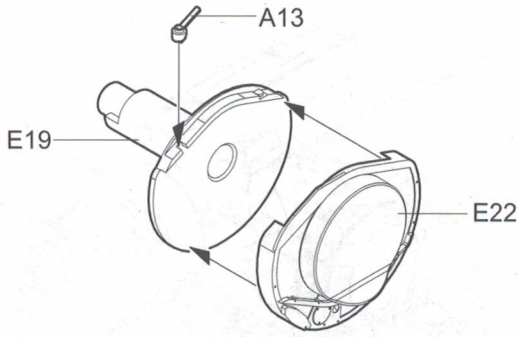

18

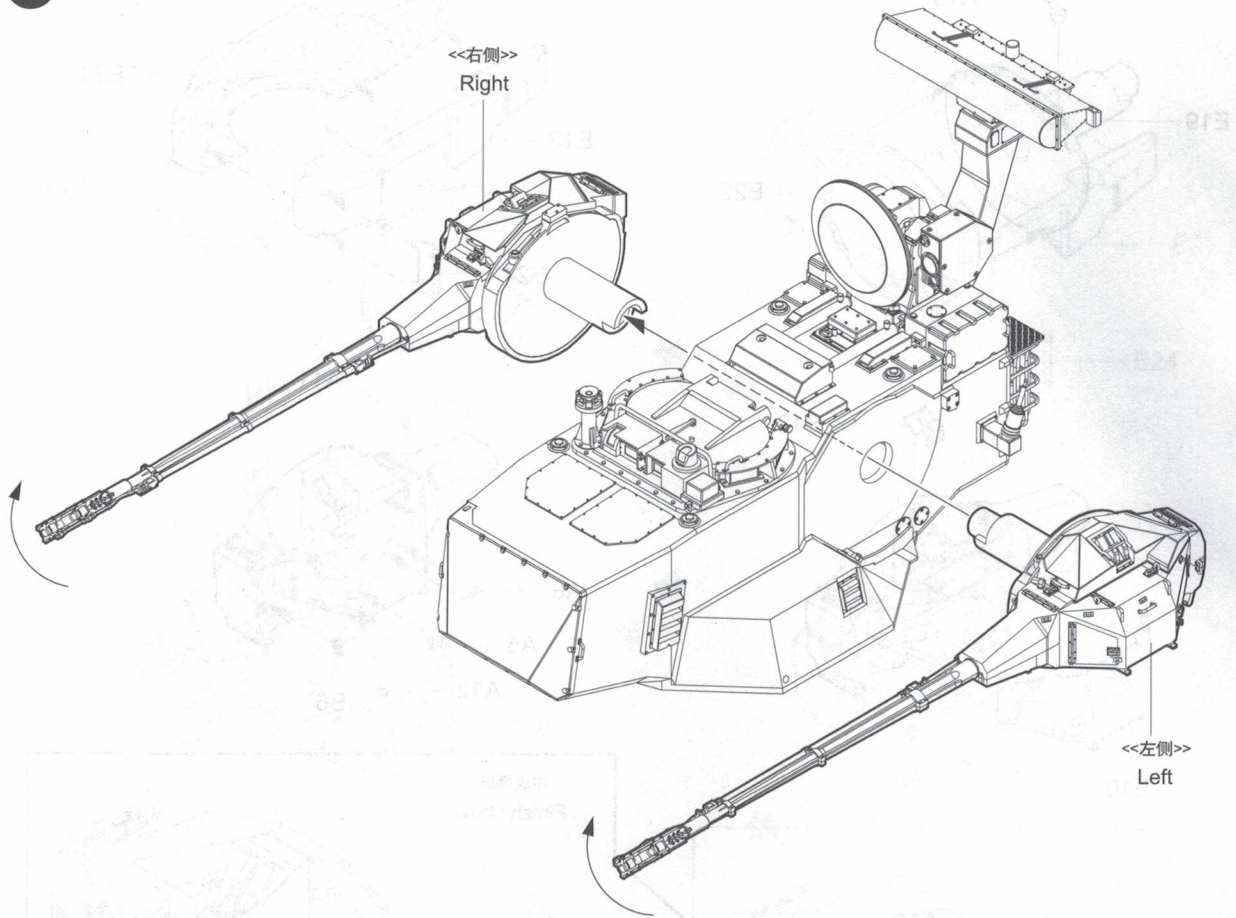

19

?
 选择
 Option
 早期型烟幕弹组装
 Assembly early version smoke bomb

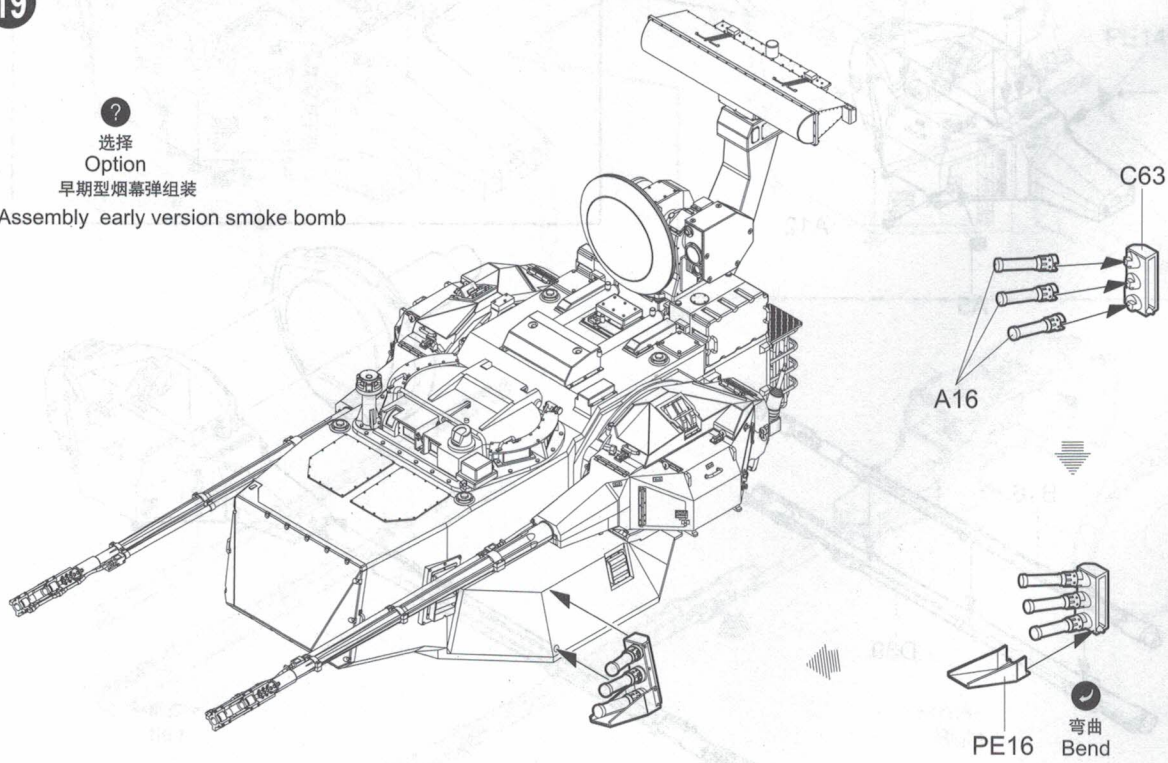

20

? 选择
Option
早期型烟幕弹组装
Assembly early version smoke bomb

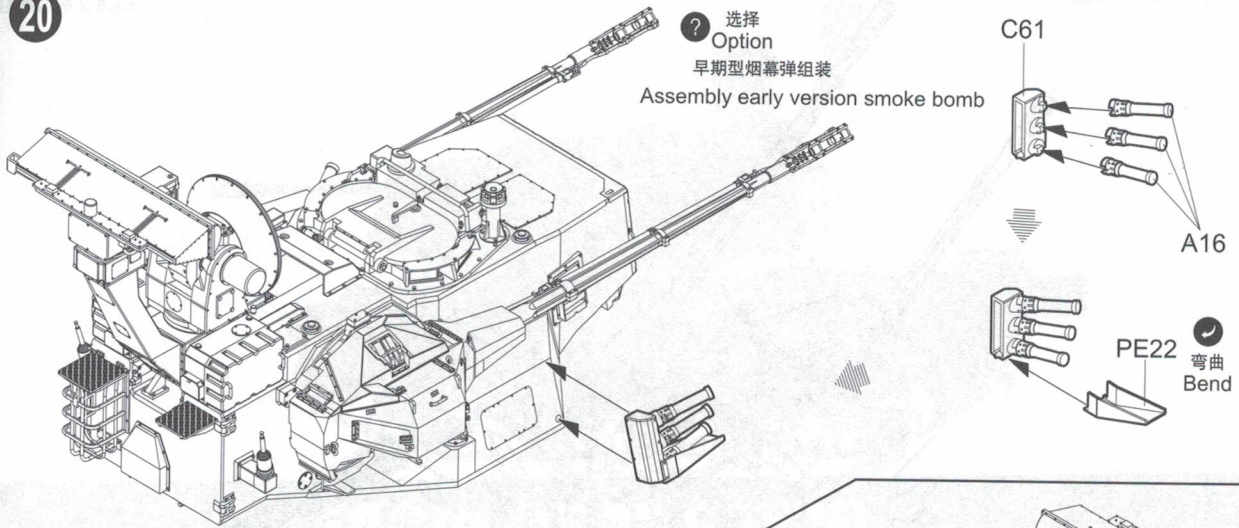

21

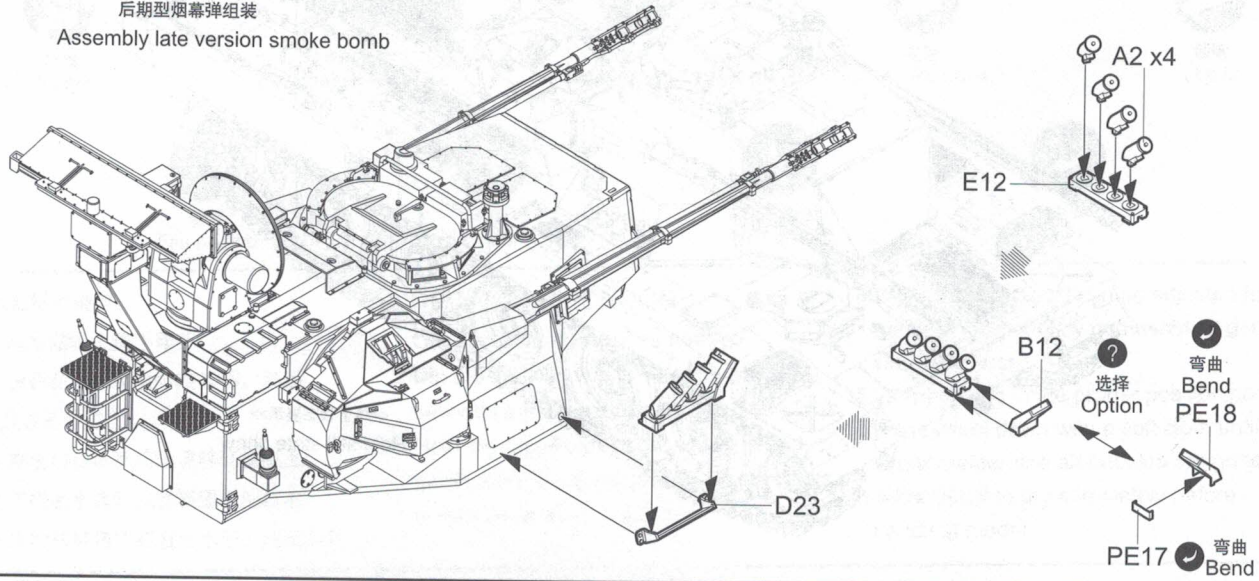
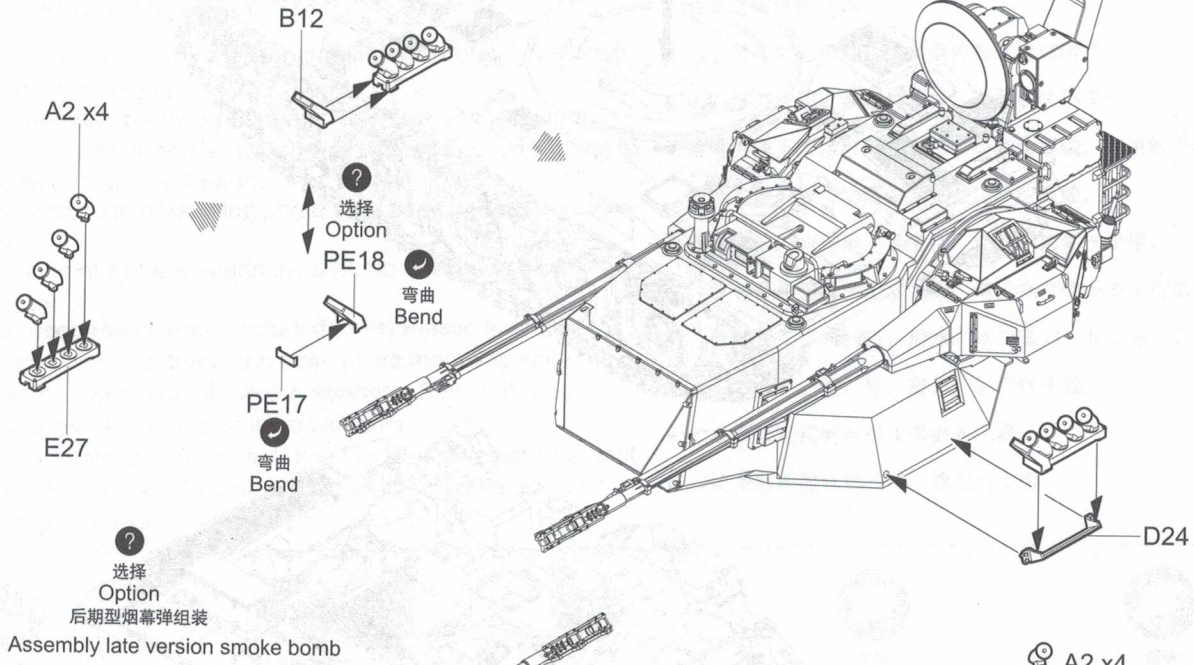

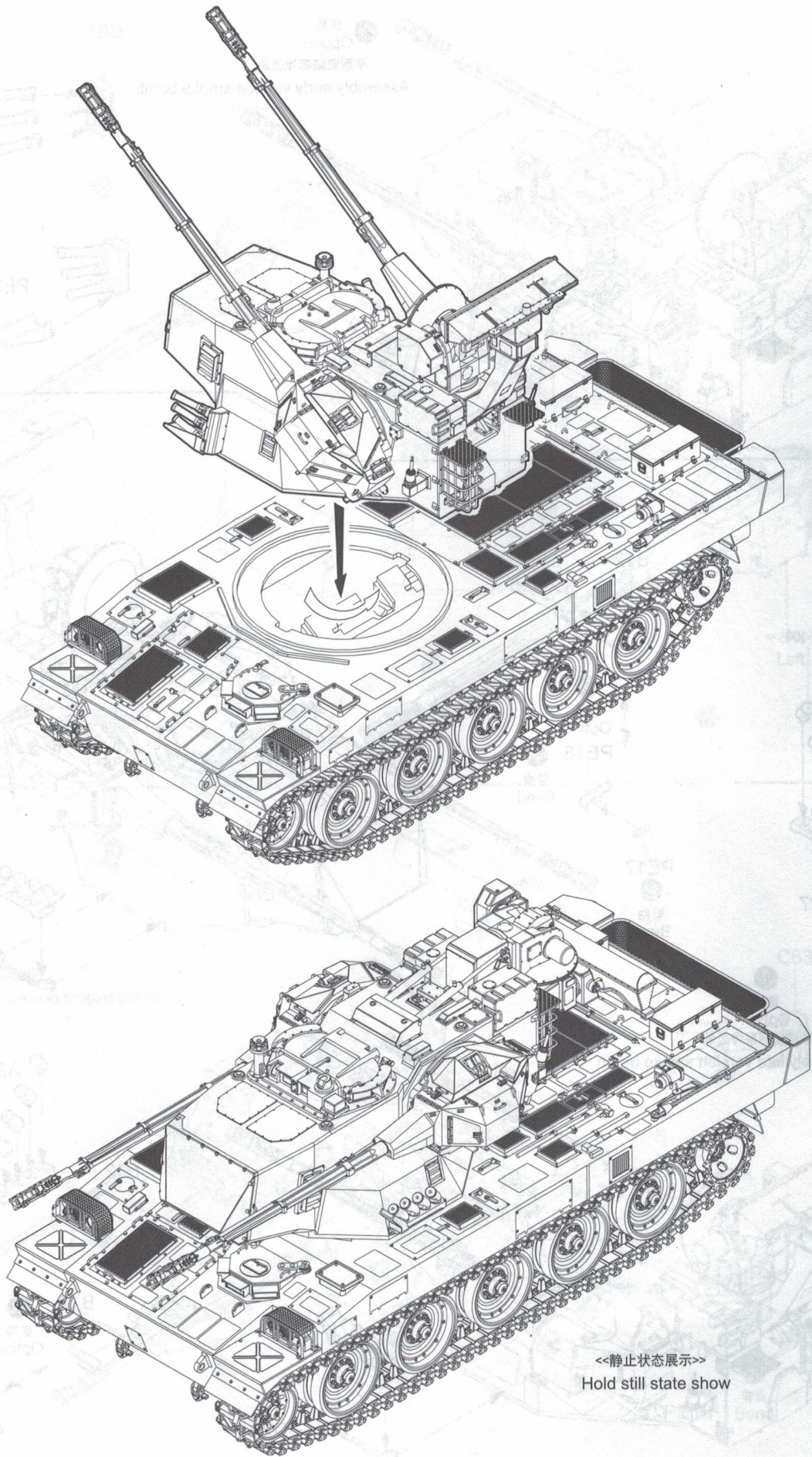

<<静止状态展示>>
Hold still state show

涂装同标贴指示

Painting & Marking guide

PAINT REFERENCE COLOUR

Color	Mr.Hobby	Vallejo	Model Master	Tamiya	Humbrol
Olive Earth 军土色	H 72 22	873	1702	XF52	29
Silver 银色	H 8 8	997	1546	X11	11

PAINT REFERENCE COLOUR

Color	Mr.Hobby	Vallejo	Model Master	Tamiya	Humbrol
Metal Black 黑灰色	H 18 23	864	1402	-	-
Dark Green 深绿军色	H 320 320	895	-	XF26	30

