

ITEM NO. 02218

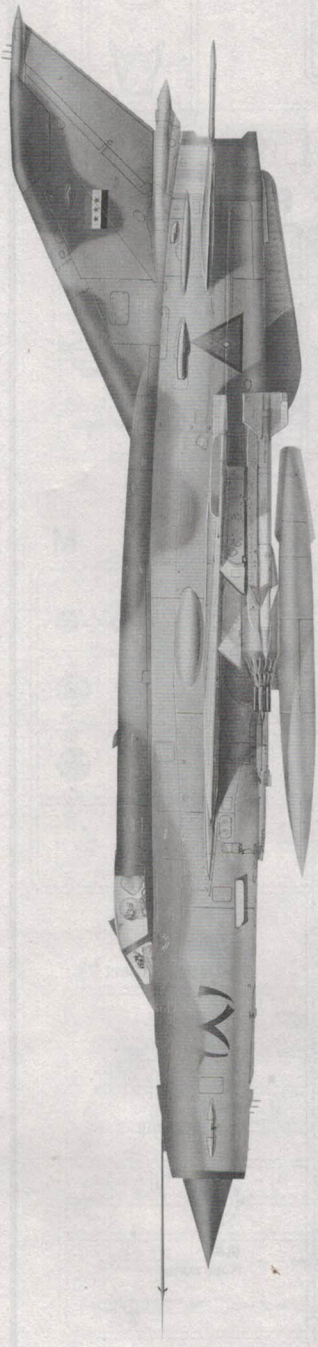

TRUMPETER



# 1:32 SCALE MiG-21MF Fishbed J

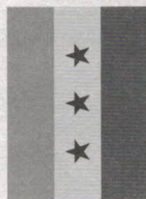
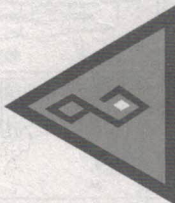
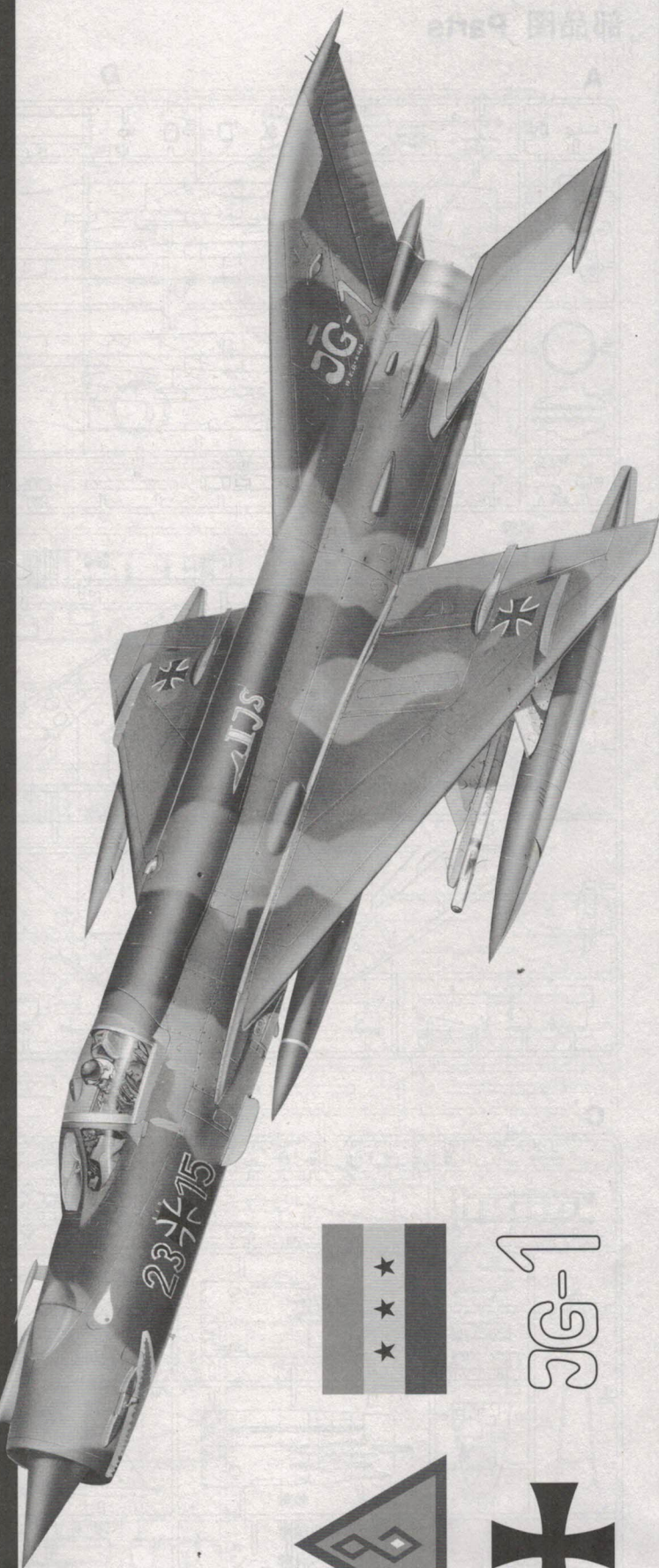

36-1

02218

1

部品图 Parts

A

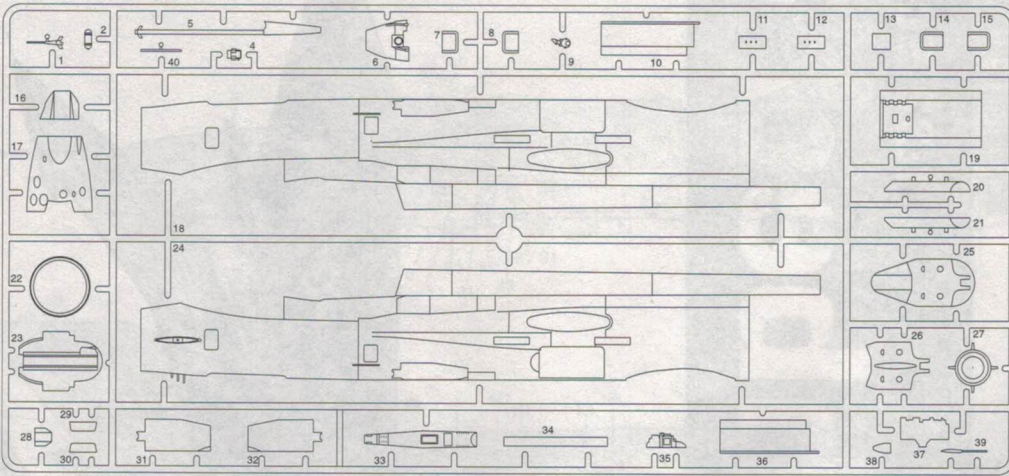

Q1

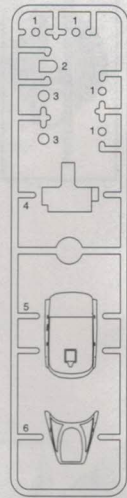

B

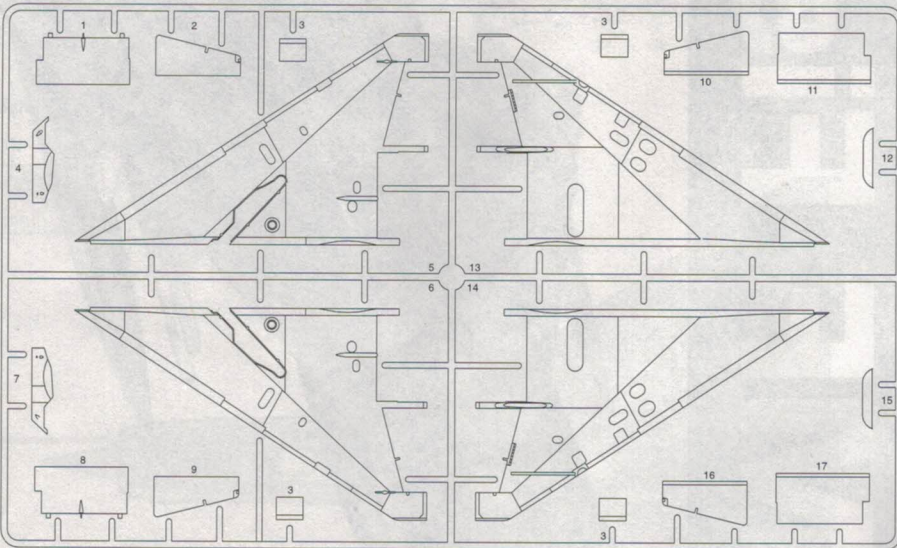

P2

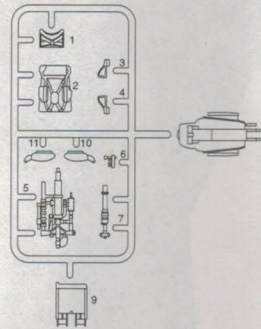

C

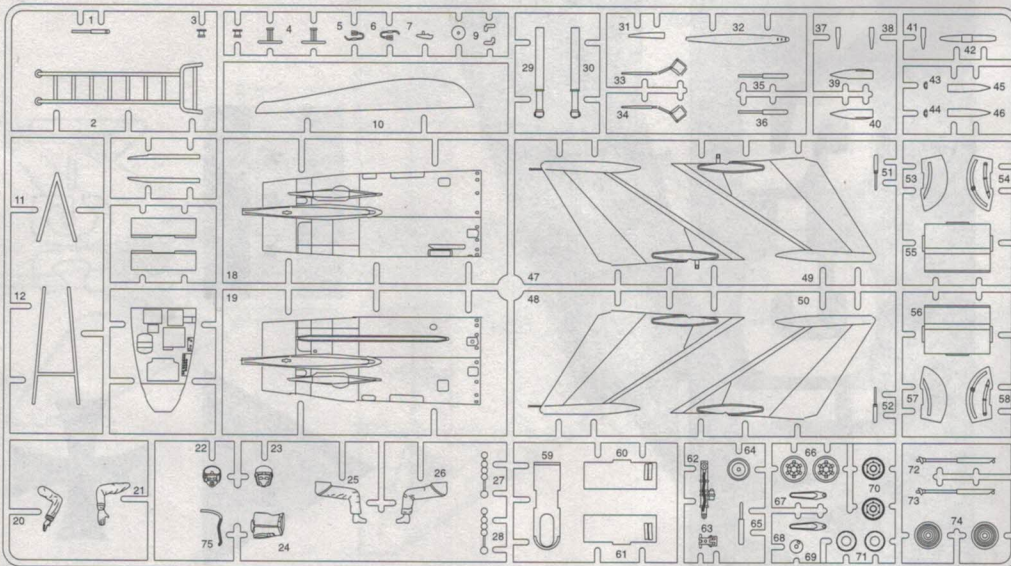

左轮柱  
Left main gear strut

右轮柱  
Right main gear strut

前轮柱  
Nose gear strut

机鼻  
Nose cone

部品图  
Parts

J

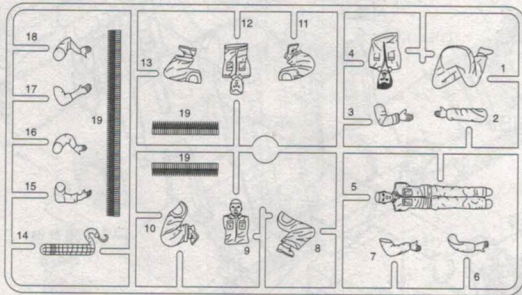

G

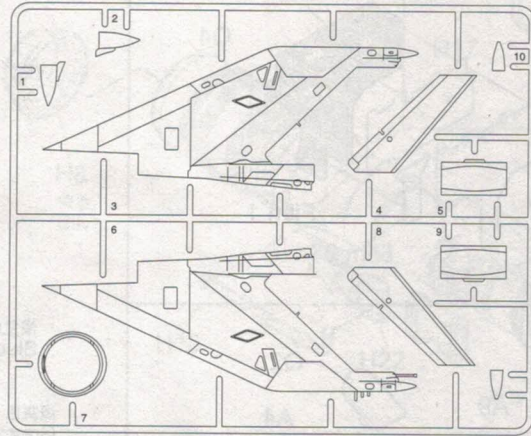

H

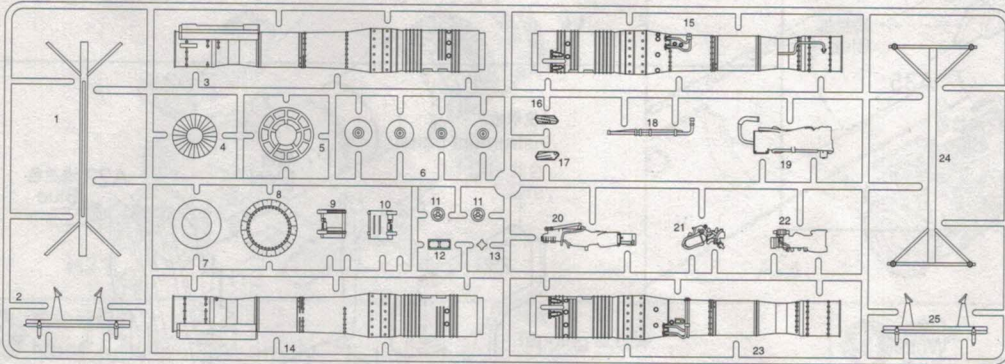

轮胎

Tire



M

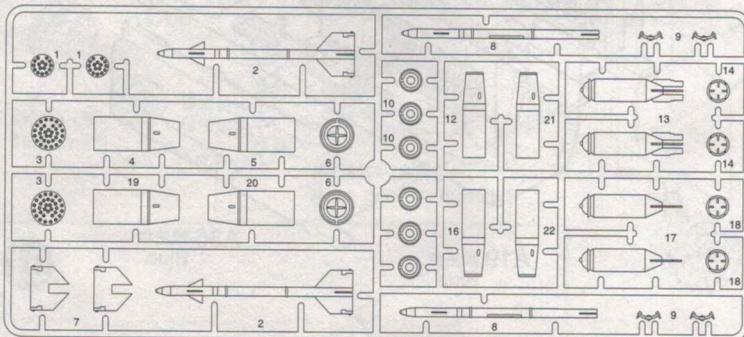

L x 3

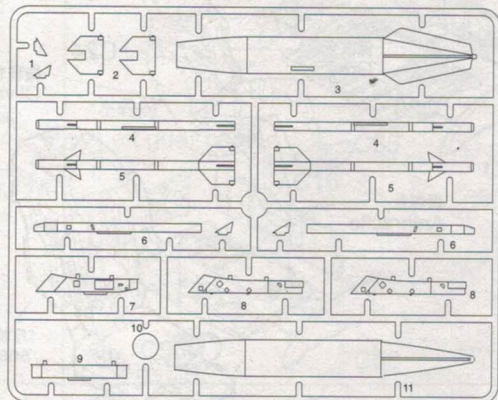

N

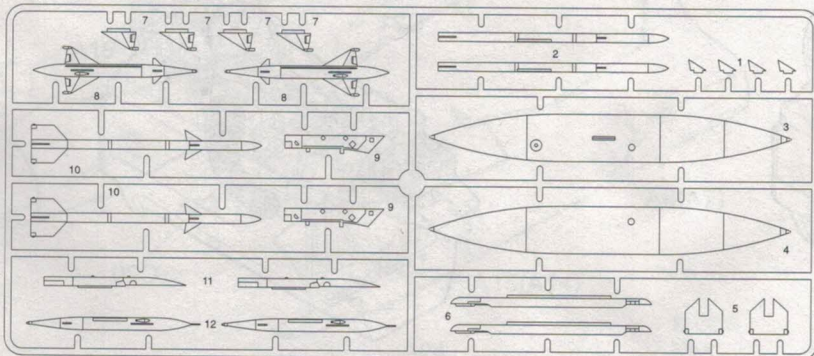

树脂部件 Resin Parts



螺丝 Screw  $\phi 1.4 \times 6\text{mm}$

水贴纸 Decal

胶片 FILM

**1** 仪表板  
Instrument panel

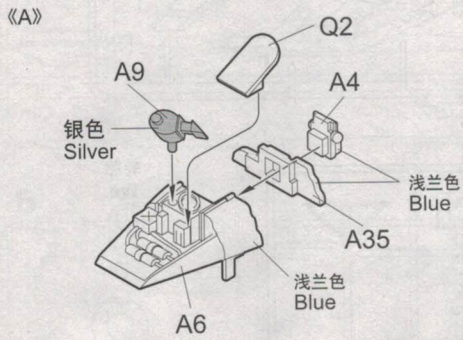
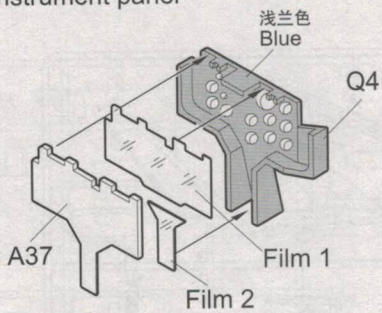

**2** 座椅  
KM-1M seat

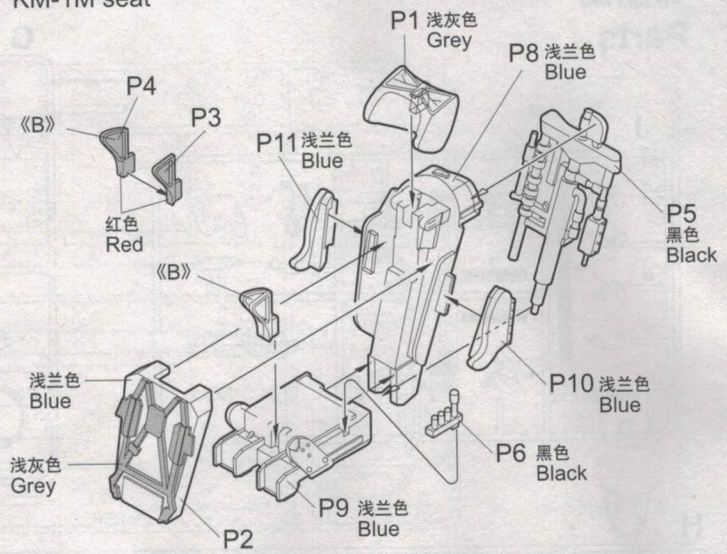

**3** 座舱的组装  
Cockpit assembly

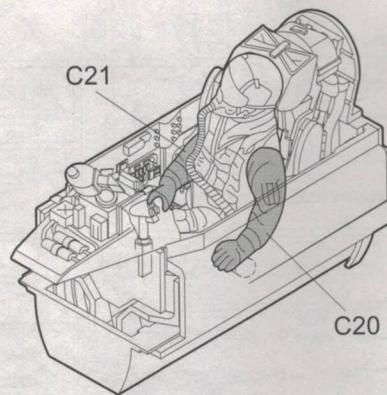
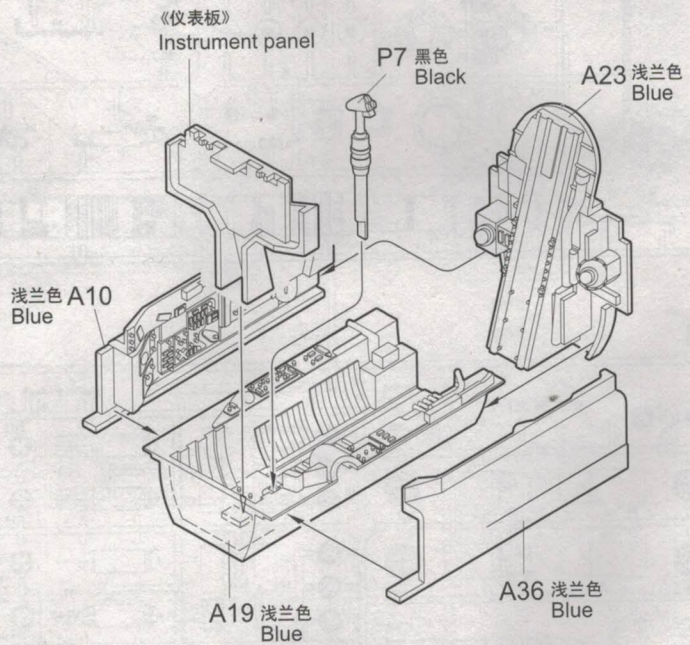
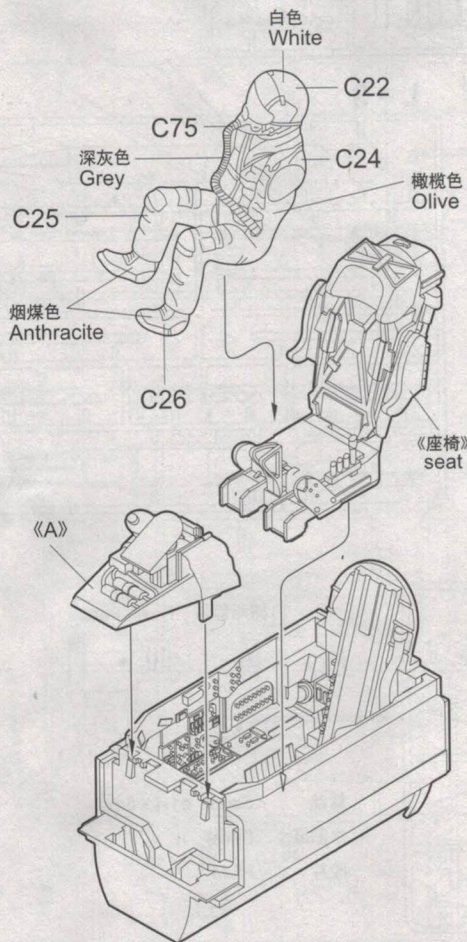



**12** 前机身组装  
Forward fuselage

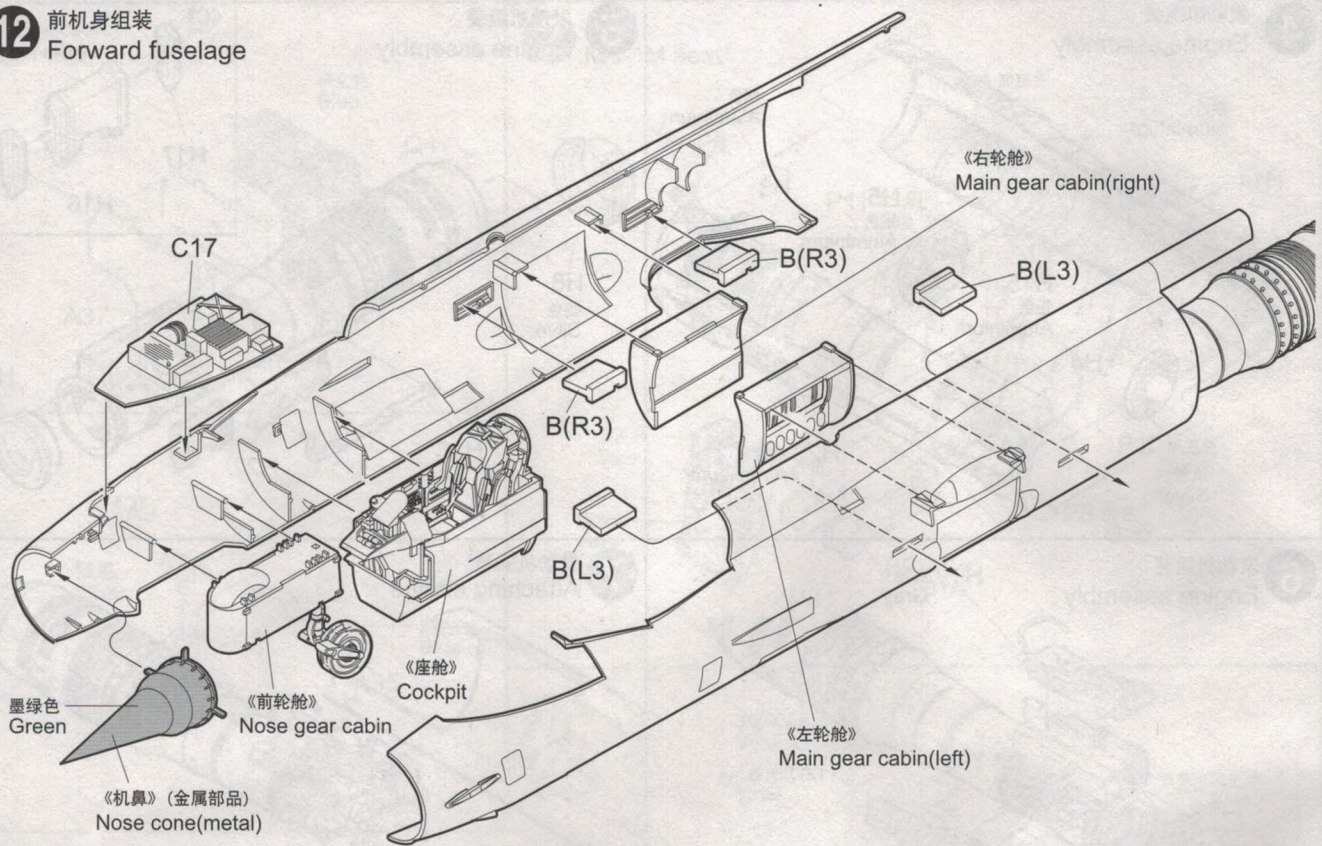

**13** 左侧机翼组装  
Left wing assembly

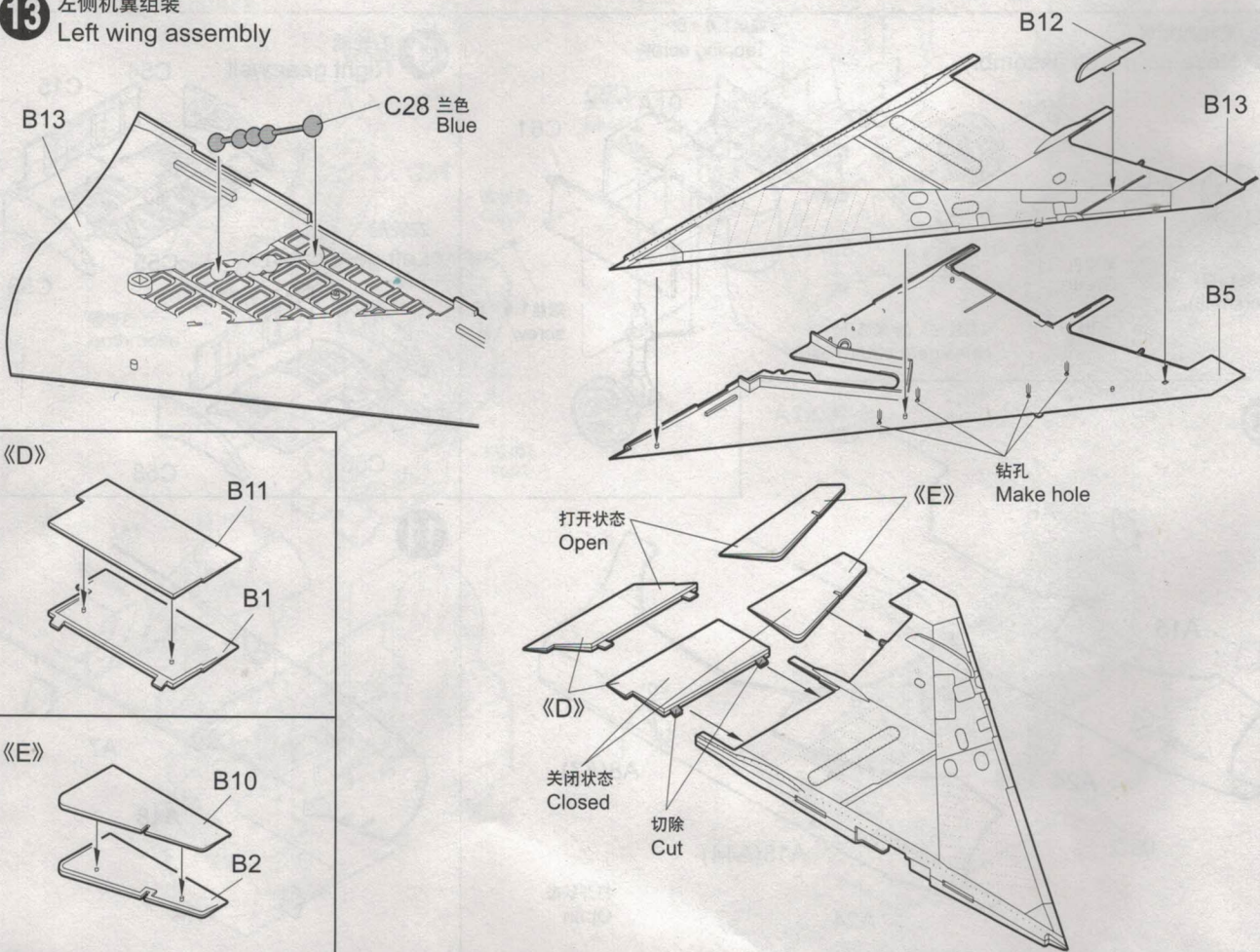

**14** 右侧机翼组装  
Right wing assembly

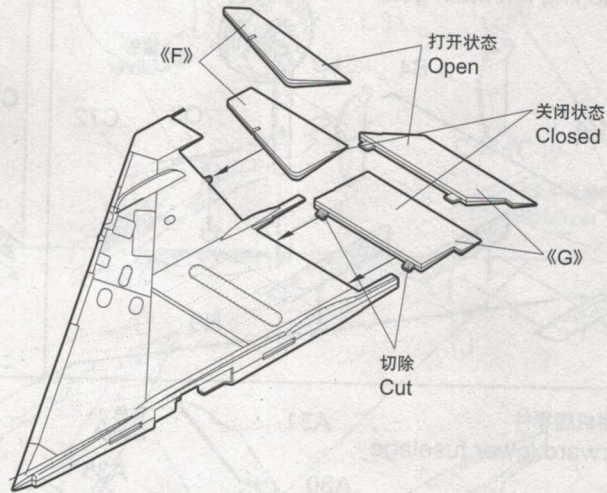
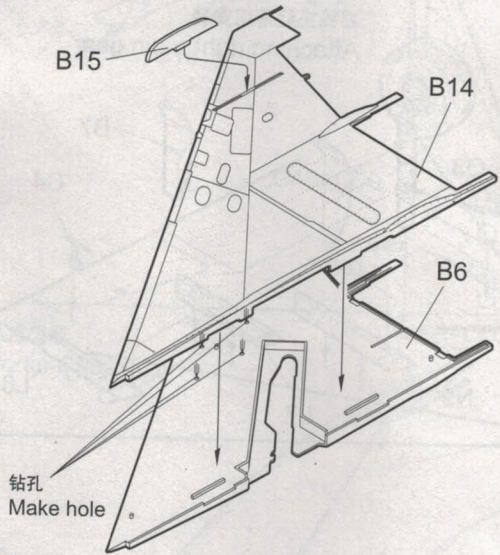
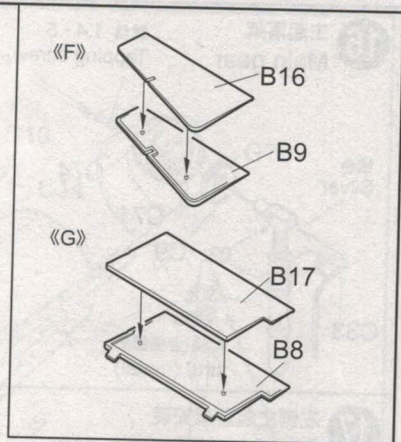
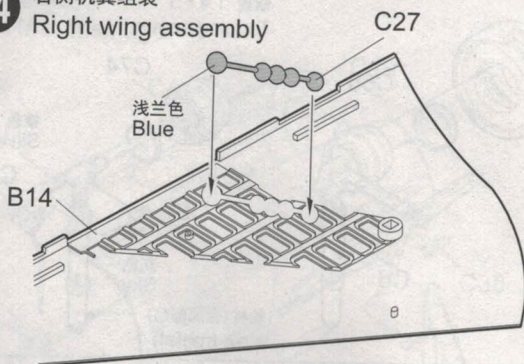

**15** 机翼的安装  
Attaching wings

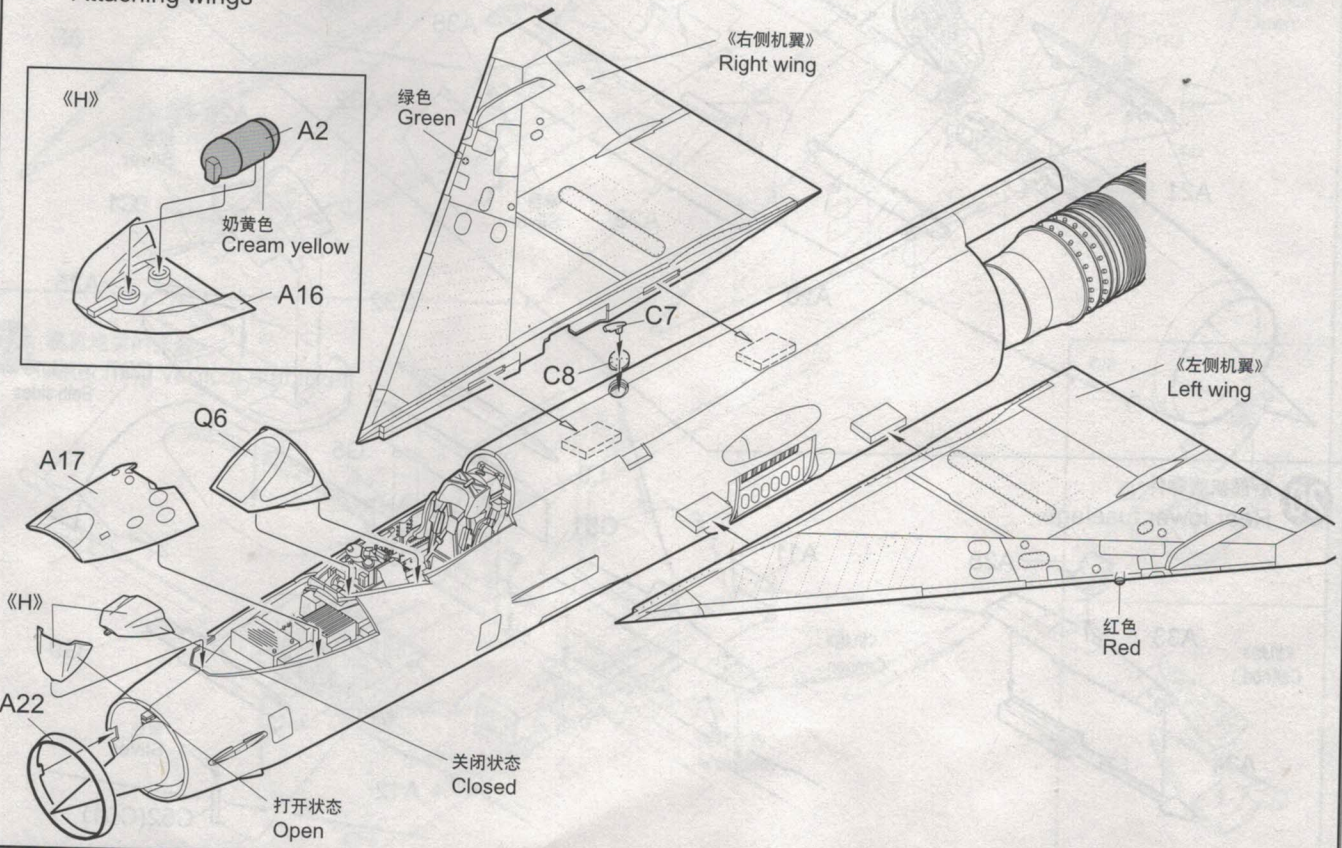
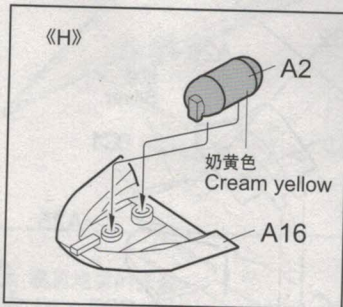

**16** 主起落架  
Main gear



**17** 左侧主起落架安装  
Attaching left main gear

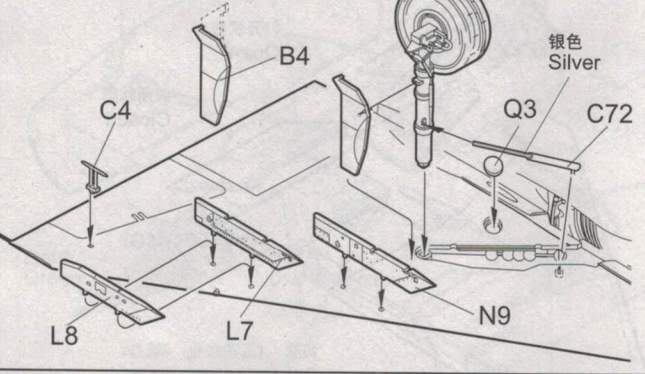

**18** 右侧主起落架安装  
Attaching right main gear

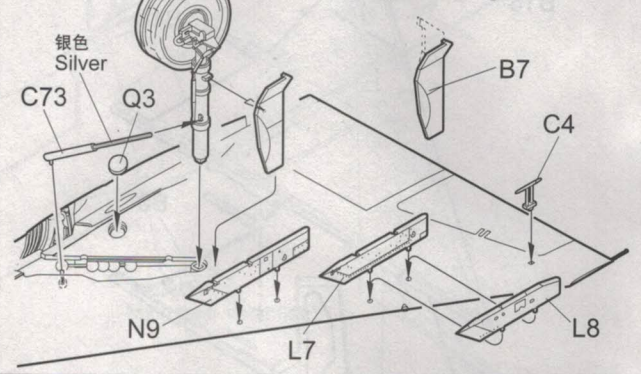

**19** 前部机腹零件  
Forward lower fuselage

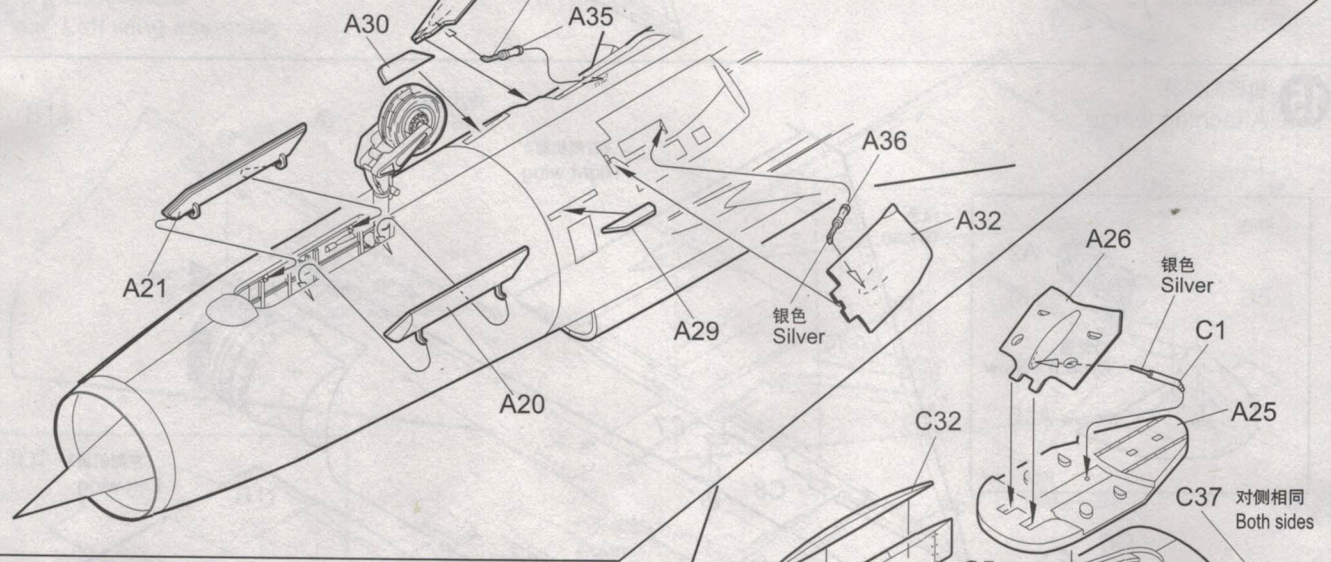

**20** 后部机腹零件  
Rear lower fuselage

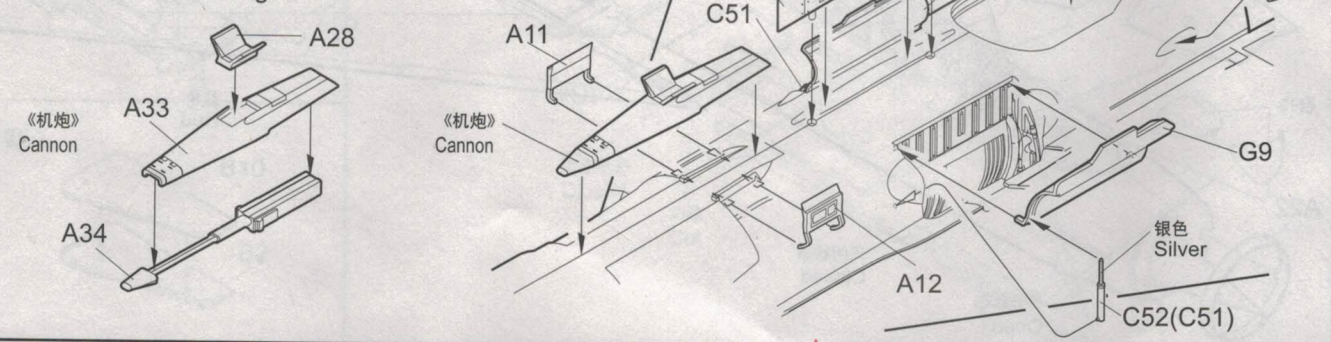

**21** 后机身  
Rear fuselage

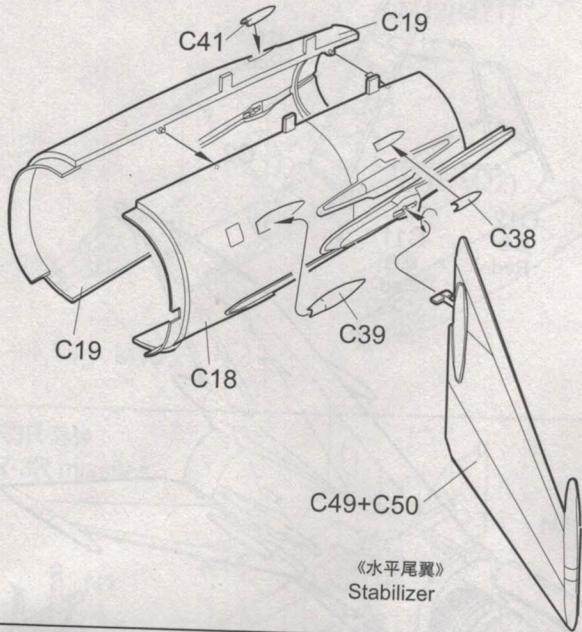

**22** 机腹后部零件  
Rear fuselage parts

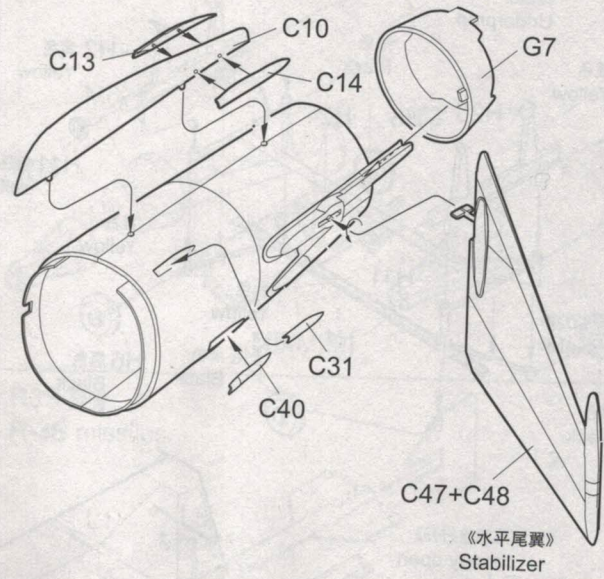

**23** 垂直尾翼  
Vertical stabilizer

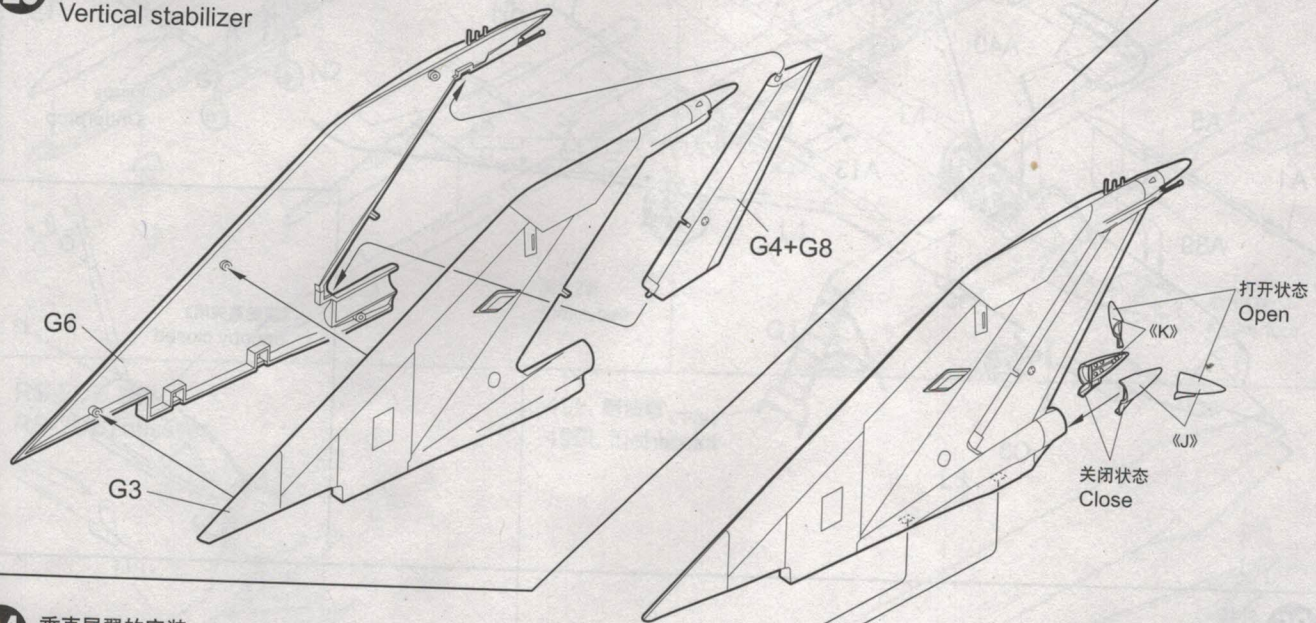

**24** 垂直尾翼的安装  
Attaching vertical stabilizer

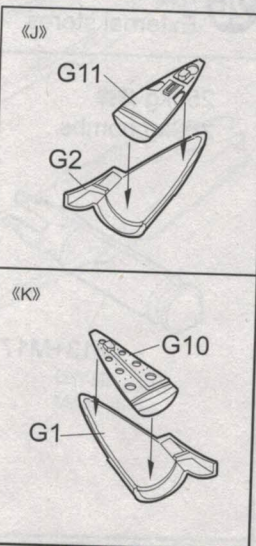
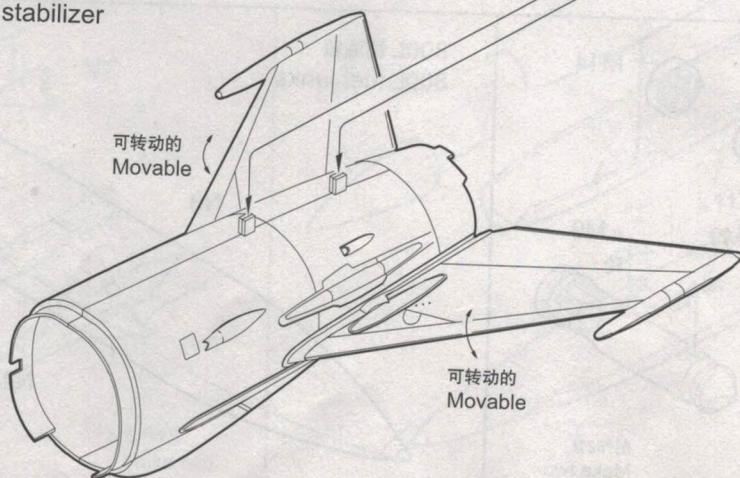

**25** 整体组装  
Finished assembly

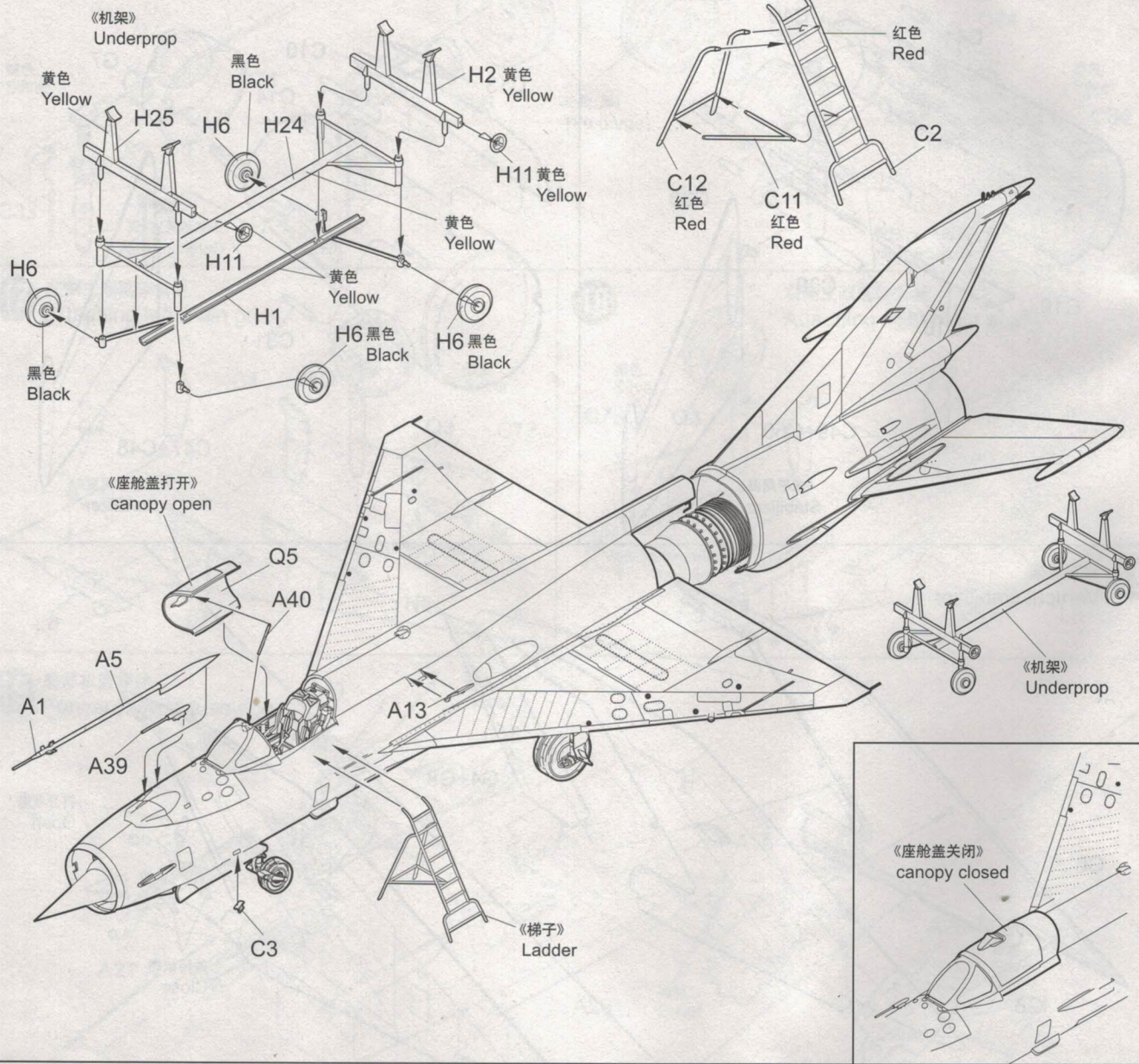

**26** 外挂  
External stores

250kg 炸弹  
250kg bombs

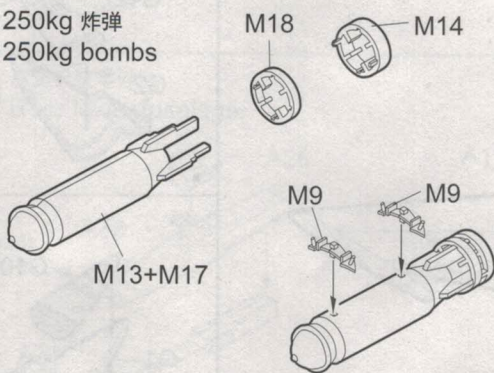

制作2套  
Make two

800L 副油箱  
800L fuel tanks

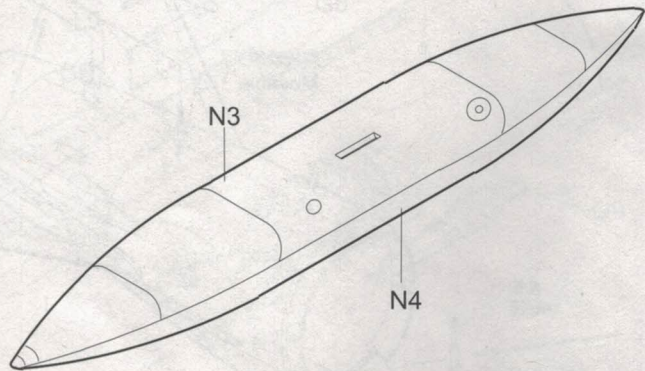

UB-16 火箭巢  
UB-16 rocket pods

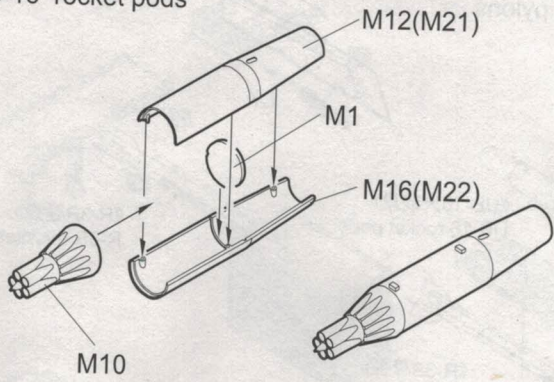

UB-32 火箭巢  
UB-32 rocket pods

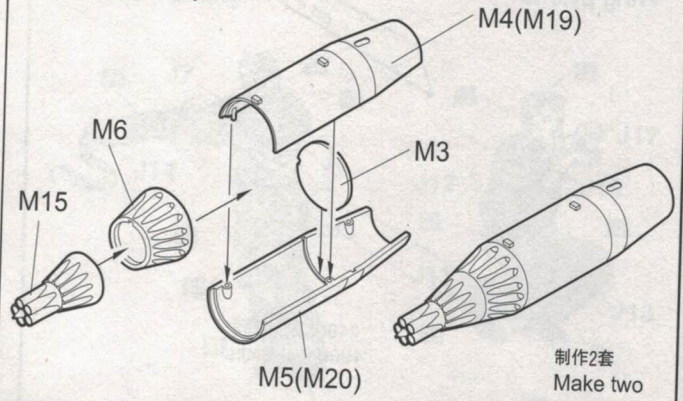

制作2套  
Make two

R3R 导弹  
R-3R missiles

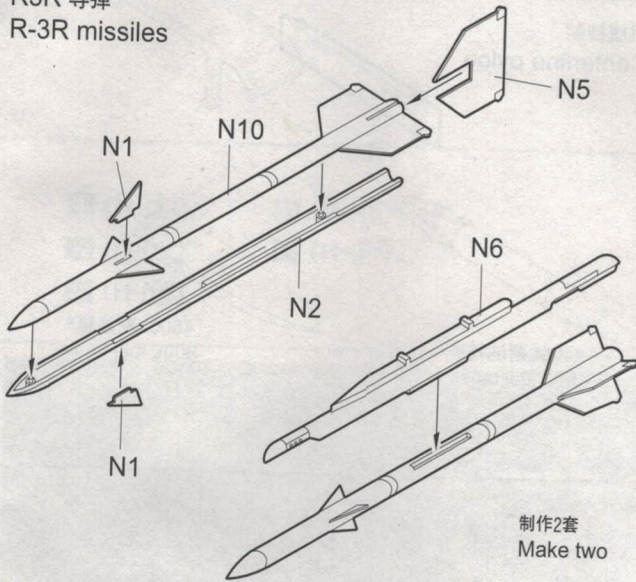

制作2套  
Make two

R3S 导弹  
R-3S missiles

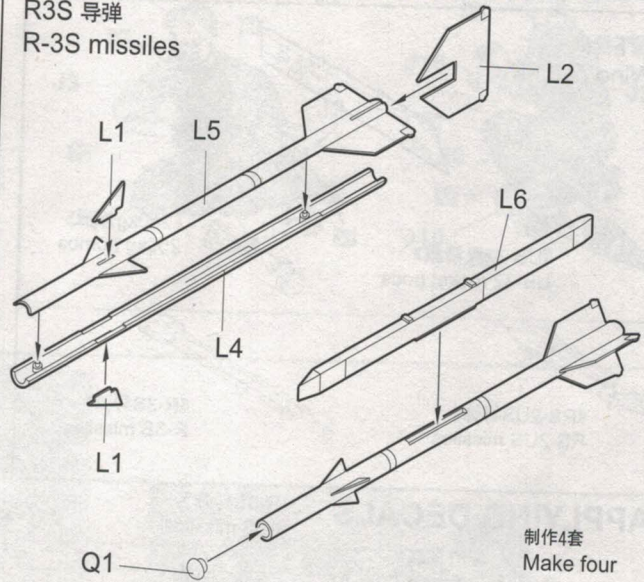

制作4套  
Make four

RS-2US 导弹  
RS-2US missiles

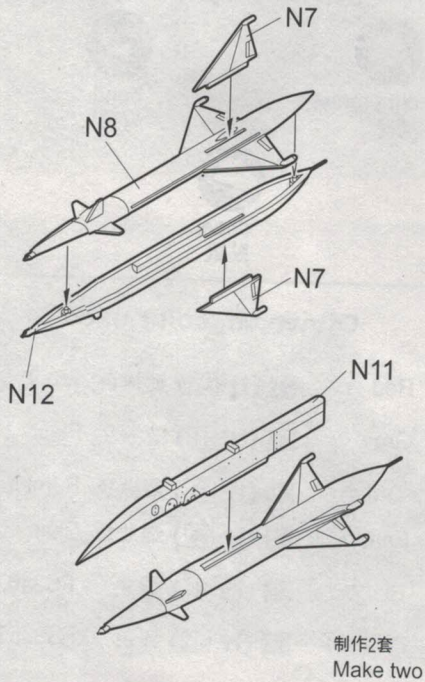

制作2套  
Make two

490I 副油箱  
490L fuel tanks

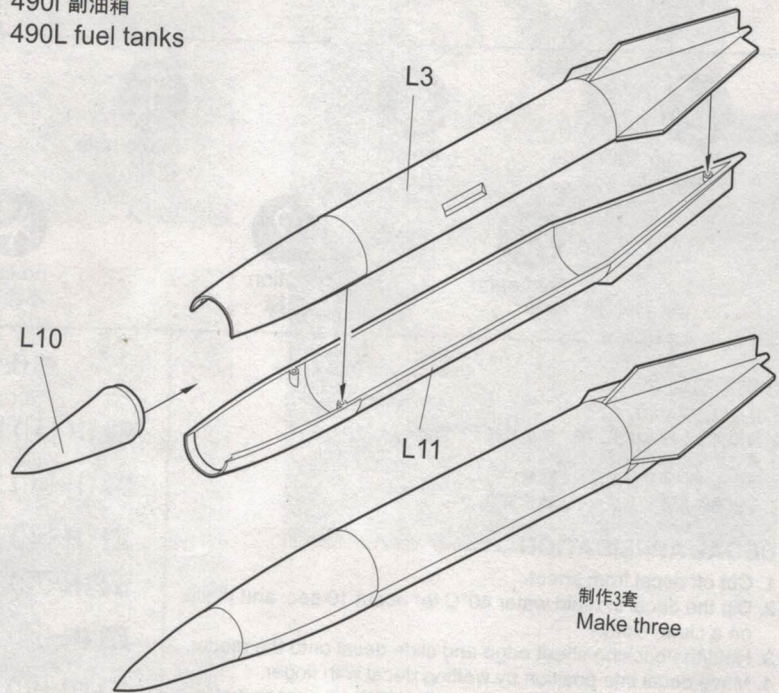

制作3套  
Make three

翼下挂架  
Wing pylons

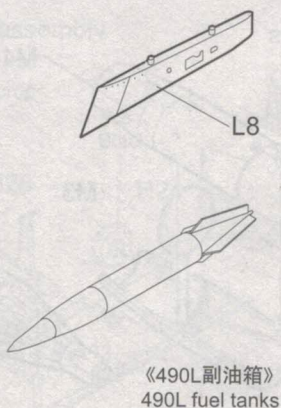

翼下挂架  
Wing pylons

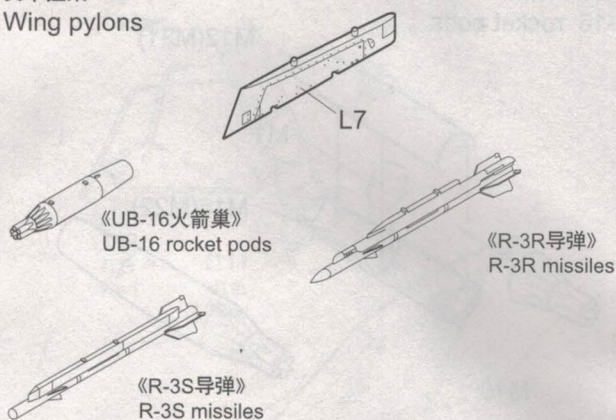

翼下挂架  
Wing pylons

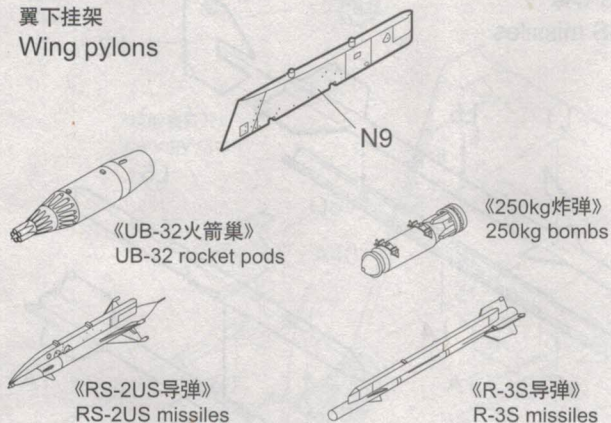

机腹挂架  
Centerline pylon

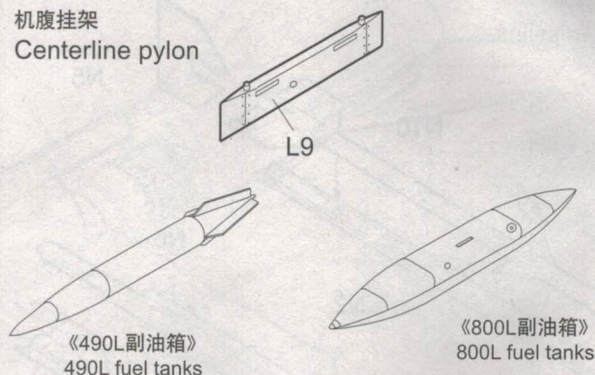

APPLYING DECALS

《R-3S导弹》  
R-3S missiles

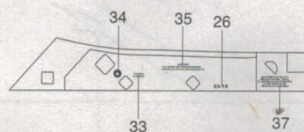
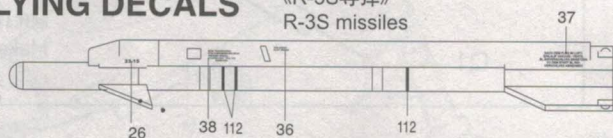

cyanoacrylate glue  
使用强力胶



weight  
配重



make hole  
钻孔



cut / remove  
切除



bend  
弯曲



file / sand  
锉平



option  
选择



no cement  
不涂胶水



decal  
贴纸

水贴纸的使用:

1. 从水贴上剪下印花;
2. 将印花放入温水中浸10秒, 然后放在干净布上。
3. 拿着印花纸板将印花移到模型上;
4. 手指蘸水将印花移到适当的位置;
5. 用软布轻压印花直至水干, 气泡消失。

DECAL APPLICATION

1. Cut off decal from sheet.
2. Dip the decal in tepid water 40°C for about 10 sec. and place on a clean cloth.
3. Hold the backing sheet edge and slide decal onto the model.
4. Move decal into position by wetting decal with finger.
5. Press decal gently down with a soft cloth until excess water and air bubbles are gone.

郡仕色使用

Gunze Mr. color used

|               |       |                |            |
|---------------|-------|----------------|------------|
| 3 (H-3) 红色    | Red   | 44 (H-27) 黄褐色  | Tan        |
| 11 (H-51) 灰色  | Gray  | 51 (H-44) 肌肤色  | Flesh      |
| 18 (H-65) 墨绿色 | Green | 61 (H-76) 烧铁色  | Burnt iron |
| 22 (H-72) 深土色 | Earth | 102 (H-96) 烟兰色 | Blue       |
| 33 (H-12) 黑色  | Black | 309 (H-309) 绿色 | FS34079    |
| 41 (H-47) 红棕色 | Brown | 313 (H-313) 黄色 | FS33531    |

人形涂装  
Figure painting

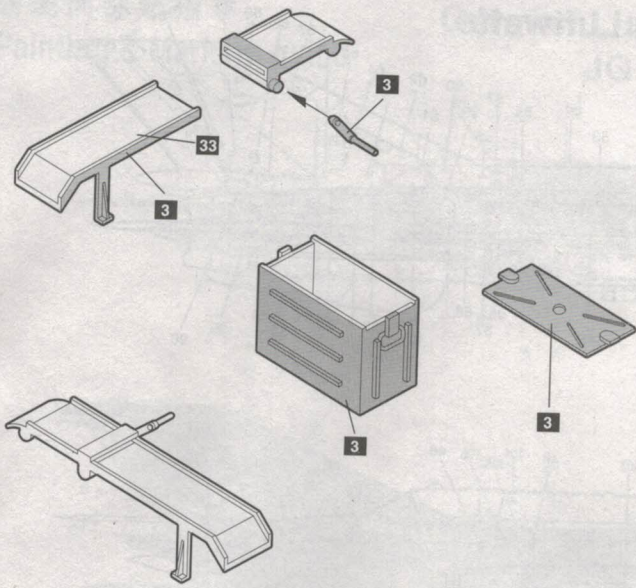

- 3 (H-3)
- 22 (H-72)
- 33 (H-12)
- 41 (H-47)
- 51 (H-44)

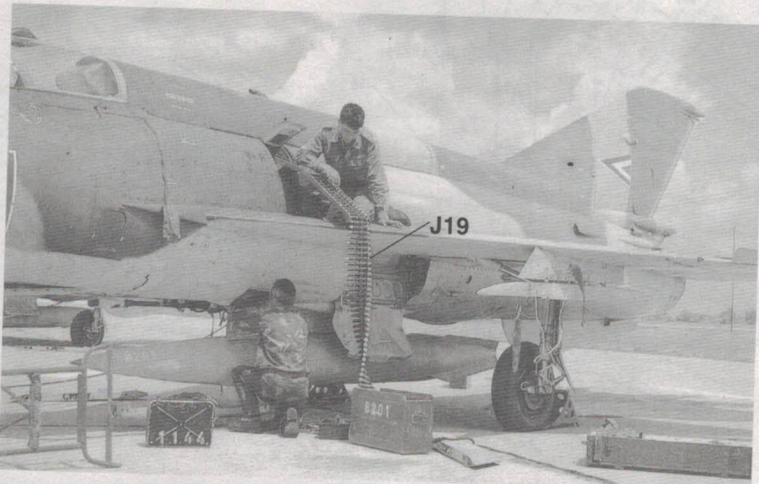
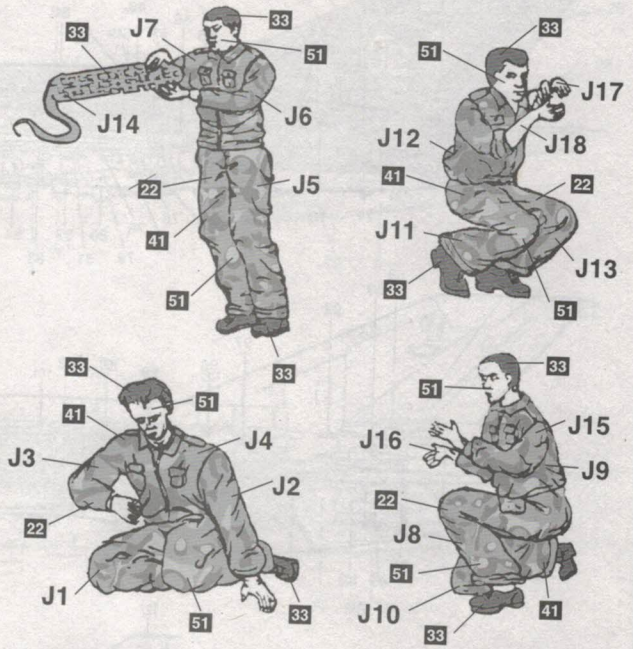

涂装同标贴指示  
Painting & Marking guide

German Luftwaffe

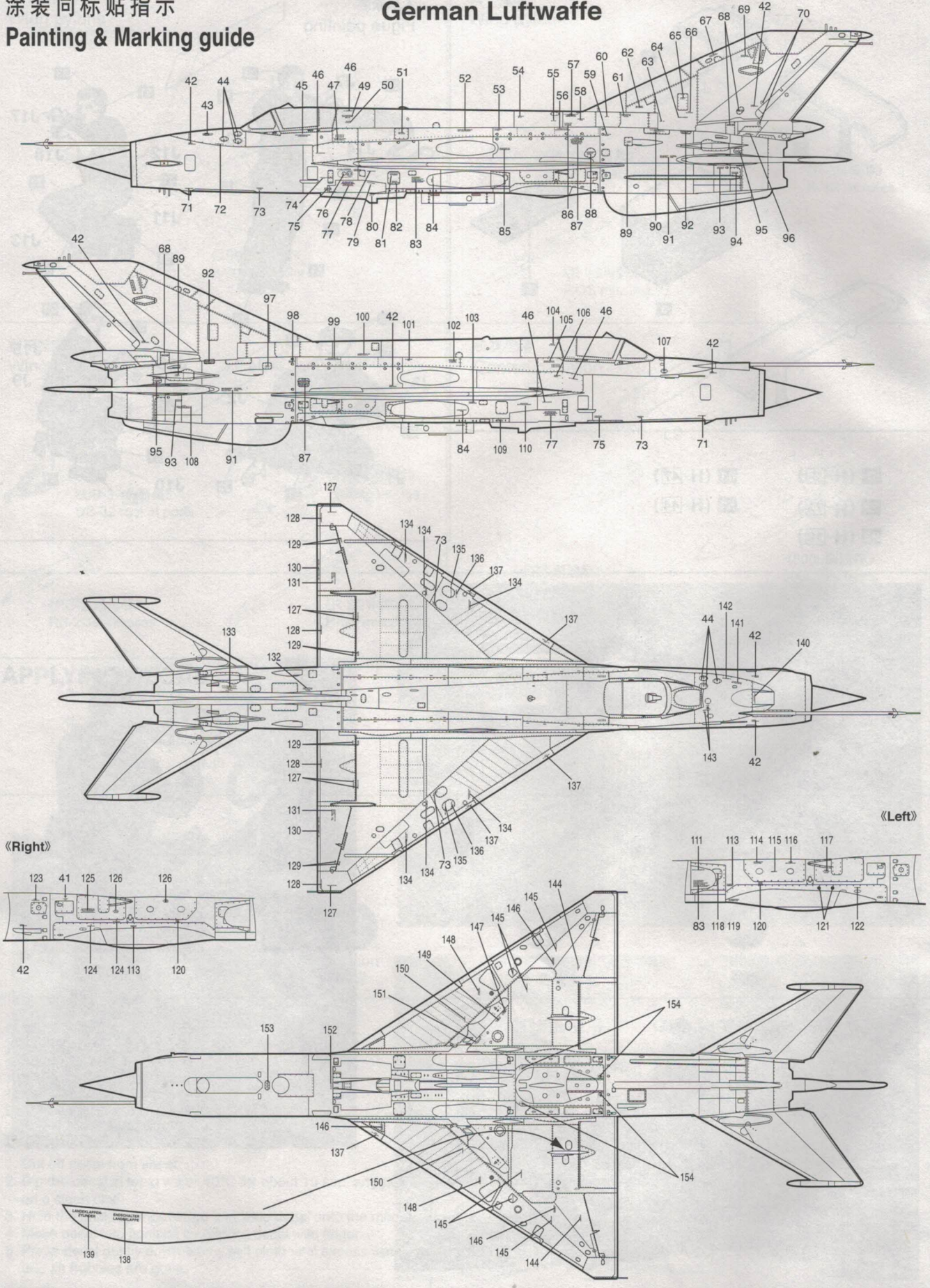

涂装同标贴指示  
Painting & Marking guide

German Luftwaffe MiG-21MF  
JG-1's MiGs

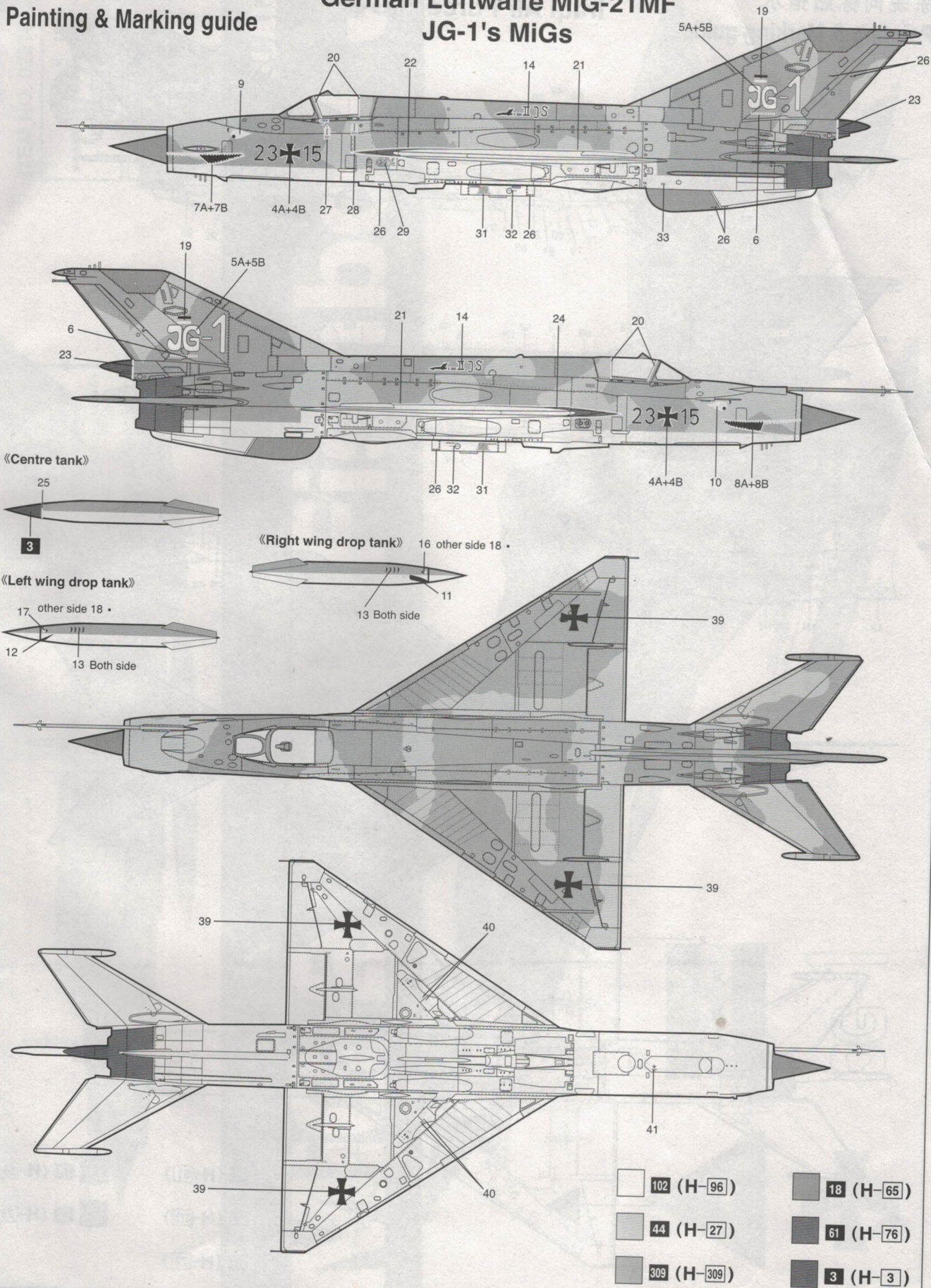

涂装同标贴指示  
Painting & Marking guide

Iraqi Air Force MiG-21MF

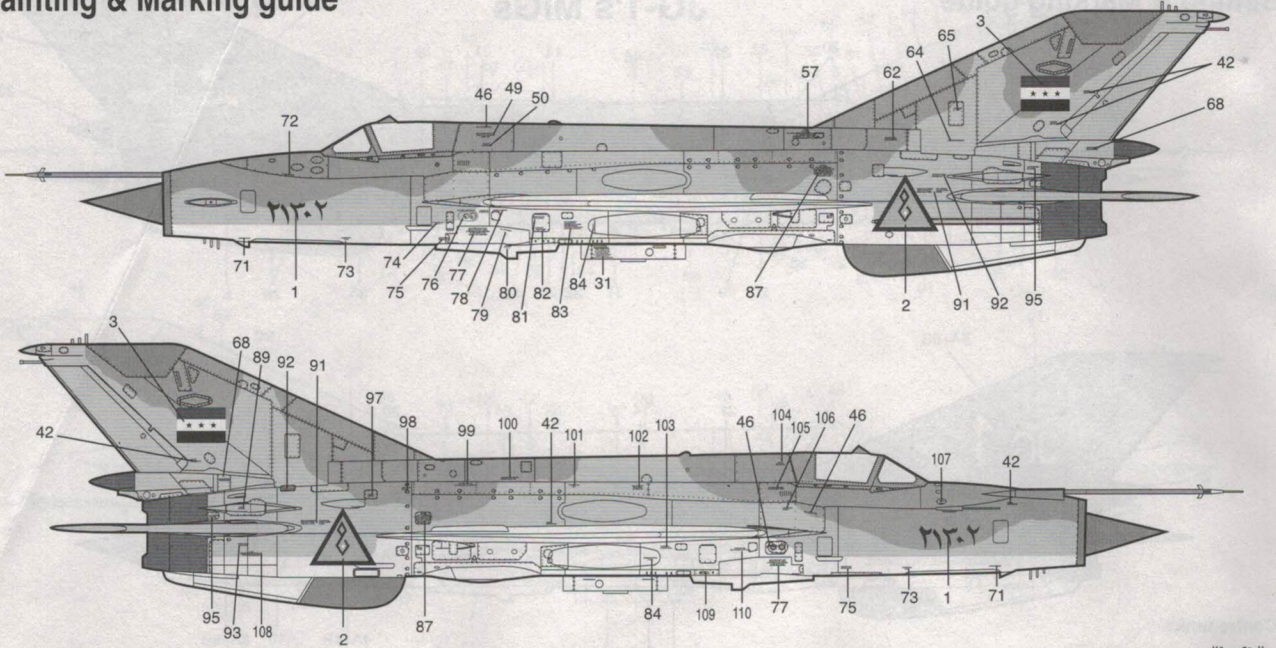

«Right»

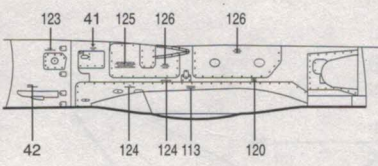

«Left»

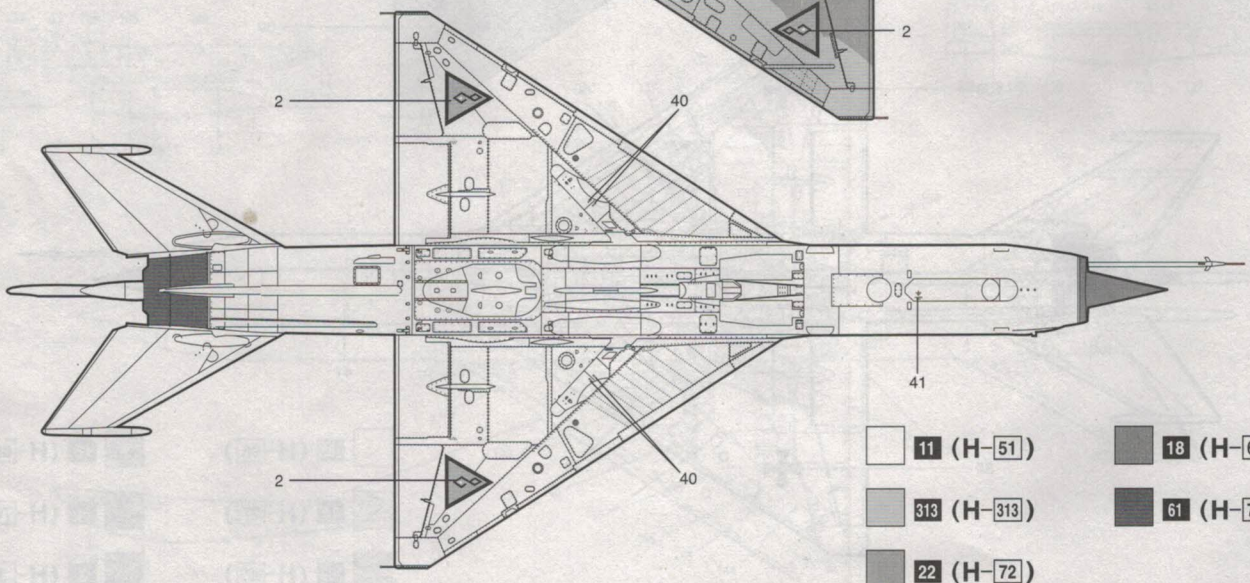
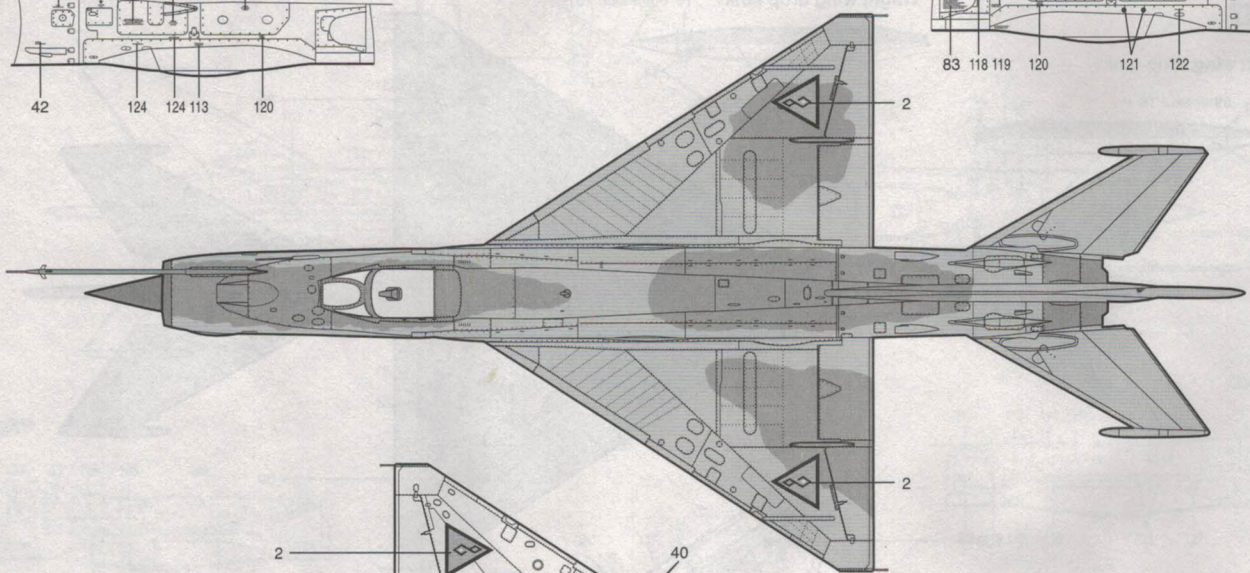
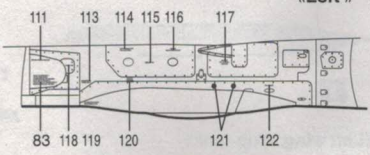

|  |             |  |           |
|--|-------------|--|-----------|
|  | 11 (H-51)   |  | 18 (H-65) |
|  | 313 (H-313) |  | 61 (H-76) |
|  | 22 (H-72)   |  |           |