



07706-0379

LEVEL 3
1 2 3 4 5



VW T3 BUS

Beiliegenden Sicherheitstext beachten / Please note the enclosed safety advice

- Ⓢ Beiliegenden Sicherheitstext beachten und nachschlagbereit halten.
- Ⓢ Please note the enclosed safety advice and keep safe for later reference.
- Ⓢ Respecter les consignes de sécurité ci-jointes et les conserver à portée de main.
- Ⓢ Houdt u aan de bijgaande veiligheidsinstructies en hou deze steeds bij de hand.
- Ⓢ Seguire le avvertenze di sicurezza allegate e tenerle a portata di mano.
- Ⓢ Observar y siempre tener a disposición este texto de seguridad adjunto.
- Ⓢ Ter em atenção o texto de segurança anexo e guardá-lo para consulta.
- Ⓢ Overhold vedlagte sikkerhedsanvisninger og hav dem liggende i nærheden.
- Ⓢ Na alltid vedlagt sikkerhetstekst klar til bruk.
- Ⓢ Beakta bifogad säkerhetstext och håll den i beredskap.
- Ⓢ Huomioi ja säilytä oheiset varoitukset.
- Ⓢ Соблюдать технику безопасности, сохранить инструкцию для дальнейших обращений.
- Ⓢ Przestrzegać załączonego tekstu dotyczącego bezpieczeństwa i mieć go zawsze pod ręką.
- Ⓢ Dodržujte tento příložený bezpečnostní text a mějte ho po ruce.
- Ⓢ A mellékelt biztonsági szöveget vegye figyelembe és tartsa fellapozásra készen.
- Ⓢ Respektujte příložený bezpečnostní text a uchovajte ho pre budúce použitie.
- Ⓢ Respectați textul de siguranță atașat și păstrați-l la îndemână.
- Ⓢ Спазвайте приложения текст за безопасност и го дръжте под ръка за справки.
- Ⓢ Priložena varnostna navodila izvajajte in jih hranite na vsem dostopnem mestu.
- Ⓢ Λάβετε υπόψη σας το συννημένο κείμενο ασφαλείας και φυλάξτε το ώστε να ανατρέχετε σε αυτό όποτε χρειάζεται.
- Ⓢ Ekteki güvenlik talimatlarını dikkate alıp, bakabileceğiniz bir şekilde muafaza ediniz.

© 2022 Revell GmbH, Henschelstr. 20-30, D-32257 Bünde.

REVELL IS THE REGISTERED TRADEMARK OF REVELL GMBH, GERMANY. www.revell.de

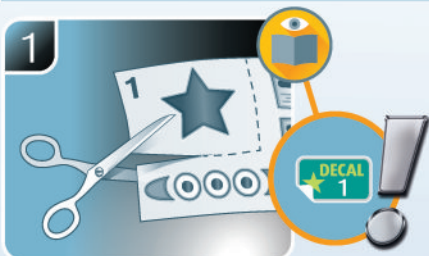
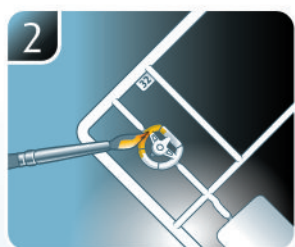
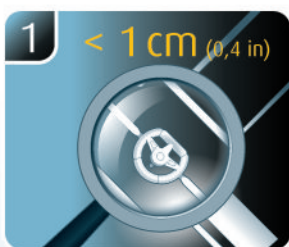
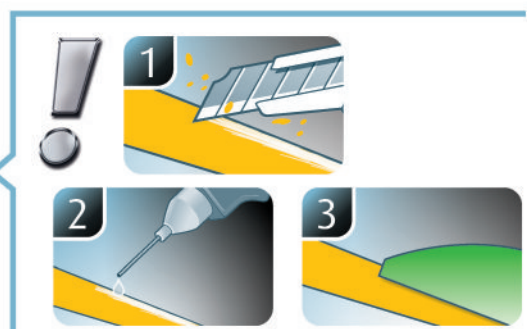
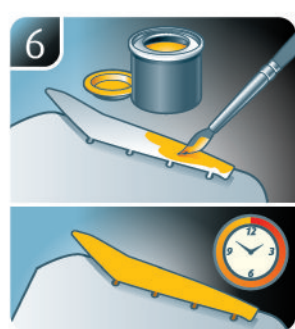
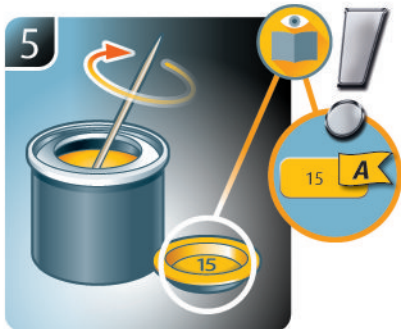
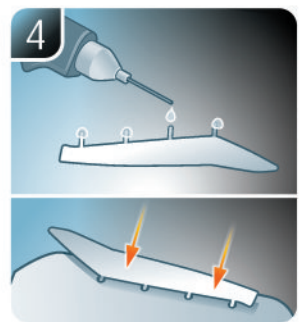
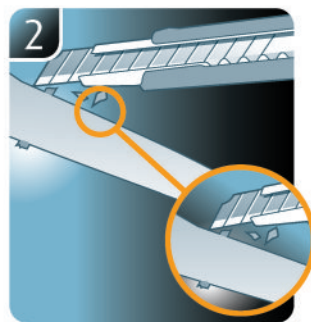
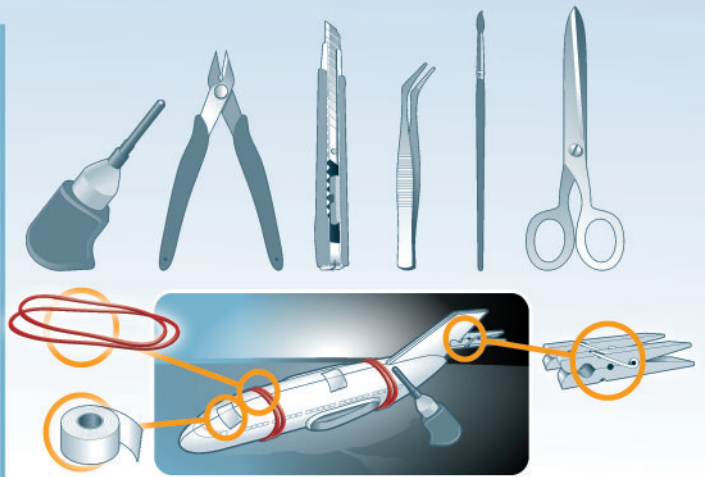

☞ Weitere Tipps und Tricks.
 ☞ Additional tips and tricks.
 ☞ Conseils et astuces supplémentaires.
 ☞ Andere tips en trucs.
 ☞ Ulteriori consigli e suggerimenti.
 ☞ Consejos y sugerencias adicionales.
 ☞ Mais dicas e truques.

☞ Flere tips og tricks.
 ☞ Flere tips og tricks.
 ☞ Ytterligere tips och tricks.
 ☞ Lisää vinkkejä ja niksejä.
 ☞ Другие советы и хитрости.
 ☞ Dalsze wskazówki i sugestie.
 ☞ Další tipy a rady.
 ☞ További ötletek és fogások.
 ☞ Dalsie tipy a triky.
 ☞ Alte sfaturi și trucuri.

☞ Други полезни съвети и трикове.
 ☞ Nadaljnji nasveti in zvijače.
 ☞ Πρόσθετες συμβουλές και κόλποι.
 ☞ Diğer öneriler ve ipuçları.

www.revell.de



- DE Kleben
- GB Glue
- FR Coller
- NL Lijmen
- IT Incollare
- ES Pegamento
- PT Colar
- DK Lim
- NO Lime
- SE Limma
- F Liimaa
- RU Клеить
- PL Przykleić
- CZ Slepění
- HU Ragassza rá
- SK Lepiť
- RO Lipiți
- BS Залепете
- S Prilepite
- GR Κολλήστε
- TR Yapıştırma



- DE Nicht kleben
- GB Don't glue
- FR Ne pas coller
- NL Niet lijmen
- IT Non incollare
- ES No pegamento
- PT Não colar
- DK Lim ikke
- NO Ikke lime
- SE Limma inte
- F Älä liimaa
- RU Не клеить
- PL Nie przyklejać
- CZ Nelepít
- HU Ne ragassza rá
- SK Nelepít
- RO Nu lipiți
- BS Не лепете
- S Ne lepite
- GR Μην κολλήσετε
- TR Yapıştırmayın



- DE Bemalen
- GB Paint
- FR Peindre
- NL Beschilderen
- IT Colorare
- ES Pintar
- PT Pintar
- DK Mal
- NO Male
- SE Måla
- F Maalaa
- RU Раскрасить
- PL Pomalować
- CZ Pomalovat
- HU Fesse be
- SK Natríť
- RO Vopsiți
- BS Боядисајте
- S Robarvajte
- GR Βάψτε
- TR Boyama



- DE Wahlweise
- GB Optional
- FR Facultatif
- NL Naar keuze
- IT Facoltativamente
- ES Opcional
- PT Opcional
- DK Valgfri
- NO Valgfritt
- SE Valfri
- F Valinnaisesti
- RU На выбор
- PL Opcjonalnie
- CZ Volitelně
- HU Választás szerint
- SK Alternativne
- RO Opțional
- BS По избор
- S Izbirno
- GR Προαιρετικά
- TR Opsiyonel



- DE Bauteile trocknen lassen.
- GB Allow the parts to dry.
- FR Laisser sécher les pièces.
- NL Onderdelen laten drogen.
- IT Lasciare asciugare i componenti.
- ES Dejar secar las piezas.
- PT Deixar as peças secar.
- DK Lad delene tørre.
- NO Tørk komponenter.
- SE Låt komponenterna torka.
- F Anna rakenneosien kuivua.
- RU Дайте деталям высохнуть.
- PL Pozostawić elementy konstrukcji do wyschnięcia.
- CZ Nechte díly uschnout.
- HU Hagyja megszáradni az alkatrészeket.
- SK Konštrukčné diely nechajte vyschnúť.
- RO Lăsați componentele să se usuce.
- BS Оставете сглобениите части да изсъхнат.
- S Osušite sestavne dele.
- GR Αφήστε τα μέρη να στεγνώσουν.
- TR Yapı parçalarını kurumaya bırakın.



- DE Zusammenbau Reihenfolge.
- GB Sequence of assembly.
- FR Ordre d'assemblage.
- NL Volgorde van montage.
- IT Sequenza di assemblaggio.
- ES Secuencia de montaje.
- PT Sequência de montagem.
- DK Samlerækkefølge.
- NO Monteringsrekkefølge.
- SE Montering ordningsföljd.
- F Kokoamisjärjestys.
- RU Последовательность сборки.
- PL Kolejność montażu.
- CZ Pořadí složení.
- HU Összerakási sorrend.
- SK Poradie zostavenia.
- RO Ordinea asamblării.
- BS Последовательност на сглобяване.
- S Vrstni red sestavljanja.
- GR Σειρά τοποθέτησης.
- TR Parçaları birleştirme sırası.



- DE Abziehbild in Wasser einweichen und anbringen.
- GB Soak and apply decals.
- FR Mouiller et appliquer les décalcomanies.
- NL Transfer in water even laten weken en aanbrengen.
- IT Immergere la decalcomania nell'acqua e applicarla.
- ES Mojar y aplicar calcomanías.
- PT Amolecer o decalque em água e aplicar.
- DK Gør overførbilledet vådt og sæt det på.
- NO Myk opp avtrekkingsbildet i vann og sett på.
- SE Blötlagg dekalen i vatten och sätt på den.
- F Pehmitä siirtokuva vedessä ja siirrä paikalleen.
- RU Опустите переводную картинку в воду и нанесите её.
- PL Namoczyc kalkomanie w wodzie i przykleić.
- CZ Nechte obtisk odmočit ve vodě a přilepte.
- HU Merítse vízbe és helyezze fel a matricát.
- SK Obtlačkový obrázok namočte do vody a priložte na plochu.
- RO Înmuiati abtibilul în apă și aplicați-l.
- BS Погнете ваденката във вода и я поставете.
- S Prelepnicu namakajte v vodi. In namestite
- GR Μουσκεψτε σε νερό και τοποθετήστε τις χαλκομανίες.
- TR Çıkartmayı suda yumuşatın ve takın.



- DE Klarsichtteile
- GB Clear parts
- FR Pièces transparentes
- NL Transparente onderdelen
- IT Parti trasparenti
- ES Piezas transparentes
- PT Peças transparentes
- DK Klare dele
- NO Klare deler
- SE Genomskinliga detaljer
- F Läpinäkyvät osat
- RU Прозрачные детали
- PL Przejrzyste części
- CZ Průhledné díly
- HU Átlátszó alkatrészek
- SK Číre diely
- RO Pieșe transparente
- BS Прозрачни части
- S Prozorni deli
- GR Διαφανή μέρη
- TR Şeffaf parçalar



- DE Bauanleitung sorgfältig lesen.
- GB Read the assembly instructions carefully.
- FR Lisez attentivement les instructions de montage.
- NL Bouwinstructies zorgvuldig doorlezen.
- IT Leggere attentamente le istruzioni per il montaggio.
- ES Lea cuidadosamente las instrucciones de montaje.
- PT Ler atentamente as instruções de montagem.
- DK Læs byggevejledningen omhyggeligt.
- NO Les byggeanvisningen nøye.
- SE Monteringsinstruktionerna skall läsas noggrant.
- F Lue kokoamisohje huolellisesti.
- RU Внимательно прочитайте инструкцию по сборке.
- PL Dokładnie przeczytać instrukcję montażu.
- CZ Přečtěte si pečlivě návod k obsluze.
- HU Figyelmesen olvassa el a szerelési útmutatót.
- SK Návod na montáž starostlivo prečítajte.
- RO Cititi cu atenție instrucțiunile de montare.
- BS Прочетете внимателно упътването за монтаж.
- S Skrbno preberite navodila za sestavo.
- GR Διαβάστε προσεκτικά τις οδηγίες κατασκευής.
- TR Yapı kılavuzunu dikkatle okuyun.



- DE Anzahl der Arbeitsgänge.
- GB Number of working steps.
- FR Nombre d'étapes de travail.
- NL Het aantal bouwstappen.
- IT Numero di fasi di lavoro.
- ES Número de pasos de trabajo.
- PT Número de passos de trabalho.
- DK Antal arbejds gange.
- NO Antall arbeidstrinn.
- SE Antal operationer.
- F Työvaiheiden määrä.
- RU Количество операций.
- PL Liczba cykli roboczych.
- CZ Počet pracovních kroků.
- HU A munkamenetek száma.
- SK Počet pracovných operácií.
- RO Numărul etapelor de lucru.
- BS Број работни стъпки.
- S Števílo delovnih postopkov.
- GR Αριθμός βημάτων εργασίας.
- TR Çalışma adımı sayısı.



- DE Gleichen Vorgang auf der gegenüberliegenden Seite wiederholen.
- GB Repeat same procedure on opposite side.
- FR Opérer de la même façon sur l'autre face.
- NL Dezelfde handeling herhalen aan de tegenoverliggende kant.
- IT Ripetere il procedimento dall'altra parte.
- ES Repetir el mismo procedimiento en el lado contrario.
- PT Repetir alguns procedimentos no lado oposto.
- DK Gentag proceduren på den modstående side.
- NO Gjenta samme forløp på motliggende side.
- SE Upprepa samma process på motsatta sidan.
- F Toista menettely vastakkaisella puolella.
- RU Повторить такие же действия на противоположной стороне.
- PL Powtórzyc te same czynności po przeciwnej stronie.
- CZ Stejný postup opakujte na protilehlé straně.
- HU Ismételve meg a műveletet az ellentétes oldalon.
- SK Rovnaký postup zopakujte na protiláhlej strane.
- RO Repetați același procedeu pe latura opusă.
- BS Повторете същите стъпки на срещуположната страна.
- S Enak postopek ponovite na nasprotni strani.
- GR Επαναλάβετε την ίδια διαδικασία στην αντίθετη πλευρά.
- TR Aynı işlem adımlarını diğer tarafta da uygulayın.



*

- DE Mit Klebeband fixieren.
- GB Attach with adhesive tape.
- FR Fixer à l'aide de ruban adhésif.
- NL Met plakband vastzetten.
- IT Fissare con nastro adesivo.
- ES Fijar con cinta adhesiva.
- PT Fixar com fita adesiva.
- DK Fastgør med tape.
- NO Fest med tape.
- SE Fixera med tejp.
- FI Kiinnittää liimanauhalla.
- RU Зафиксировать липкой лентой.
- PL Przymocować za pomocą taśmy samoprzylepnej.
- CZ Připevněte lepicí páskou.
- HU Rögzítse ragasztószalaggal.
- SK Fixujte lepiacou páskou.
- RO Fixați cu bandă adezivă.
- GR Φιξισαίτε σ τικσο.
- SJ Pritidite z lepilnim trakom.
- GR Στερεώστε με κολλητική ταινία.
- TR Yapıştırma bandi ile sabitleyin.



- DE Mit einem Messer abtrennen.
- GB Detach with knife.
- FR Détacher au couteau.
- NL Met een mesje afsnijden.
- IT Separare con un coltello.
- ES Separar con cuchillo.
- PT Separar com uma faca.
- DK Skær af med en kniv.
- NO Separer med kniv.
- SE Skall skiljas av med en kniv.
- FI Erota veitsellä.
- RU Отделить ножом.
- PL Oddzielić za pomocą noża.
- CZ Oddělte nožem.
- HU Válassza le késsel.
- SK Oddajte nožom.
- RO Desprindeți cu un cuțit.
- GR Откъснете с нож.
- SJ Odrežite z ustreznim rezilom.
- GR Αφαιρέστε με ένα μαχαίρι.
- TR Bir bıçak ile kesin.



- DE Nicht abtrennen.
- GB Do not detach.
- FR Ne pas séparer.
- NL Niet scheiden.
- IT Non separare.
- ES No separar.
- PT Não separar.
- DK Må ikke rives af.
- NO Ikke separer.
- SE Skall inte skiljas av.
- FI Älä erota.
- RU Не отделять.
- PL Nie oddzielać.
- CZ Neoddělujte.
- HU Ne válassza le.
- SK Neoddľujte.
- RO Nu desprindeți.
- GR Не откъсвайте.
- SJ Ne odstranjujte.
- GR Μην αφαιρείτε.
- TR Kesmeyin.



*

- DE Pinzette benutzen.
- GB Use tweezers.
- FR Utiliser une pince à épiler.
- NL Pincet gebruiken.
- IT Utilizzare una pinzetta.
- ES Usar pinzas.
- PT Utilizar uma pinça.
- DK Brug pincet.
- NO Bruke pinsetter.
- SE Använd pincett.
- FI Käytä pinsettejä.
- RU Пользуйтесь пинцетом.
- PL Użyć pęsety.
- CZ Použijte pinzetu.
- HU Használjon csipeszt.
- SK Použite pinzetu.
- RO Utilizați penseta.
- GR Използвайте пинцета.
- SJ Uporabite pinceto.
- GR Χρησιμοποιήστε τσιμπίδα.
- TR Cımbız kullanın.



- DE Abbildung zusammengesetzter Teile.
- GB Illustration of assembled parts.
- FR Figure représentant les pièces assemblées.
- NL Afbeelding van samengevoegde onderdelen.
- IT Foto delle parti assemblate.
- ES Figura de las piezas montadas.
- PT Ilustração das peças montadas.
- DK Illustration af samlede dele.
- NO Figur av sammensatte deler.
- SE Bild på sammansatta detaljer.
- FI Koottujen osien kuva.
- RU Изображение смонтированных деталей.
- PL Rysunek połączonych części.
- CZ Zobrazení spojených dílů.
- HU Összerakott alkatrészek ábrája.
- SK Obrázok dielov, ktoré sa majú zmontovať.
- RO Figura reprezentând piesele asamblate.
- GR Изображение на слобените части.
- SJ Slika sestavljenih delov.
- GR Απεικόνιση των τοποθετημένων μερών.
- TR Birleştirilmiş parçaların resmi.



- DE Entfernen
- GB Remove
- FR Détacher
- NL Verwijderen
- IT Rimuovere
- ES Eliminar
- PT Remover
- DK Fjern
- NO Fjerne
- SE Ta bort
- FI Poistaa
- RU Удалить
- PL Usunąć
- CZ Odstranit
- HU Eltávolítani
- SK Odstrániť
- RO Îndepărtați
- GR Αφαιρέστε
- SJ Odstranitev
- GR Αφαιρέστε
- TR Çıkar



*

- DE Zur Anbringung der Abziehbilder empfohlen.
- GB Recommended for affixing the decals.
- FR Recommandé pour l'application des décalcomanies.
- NL Aanbevolen voor het aanbrengen van de transfers.
- IT Raccomandato per l'applicazione delle decalcomanie.
- ES Recomendado para fijar bien las calcomanías.
- PT Recomendado para a fixação dos autocolantes.
- DK Anbefales til anbringelse af overføringsbillederne.
- NO Anbefales til å feste avtrekksbilder.
- SE Rekommenderad för montering av klisterdekalerna.
- FI Suositellaan siirtokuvien siirtämiseen.
- RU Рекомендуется для нанесения переводных картинок.
- PL Zalecane do przyklejenia kalkomanii.
- CZ Doporúčujeme k umiestneniu obtiskovacích obrázků.
- HU A matrica felhelyezéséhez ajánlható.
- SK Odporúča sa pre umiestnenie obľáčkových obrázků.
- RO Recomandat pentru aplicarea abtibilurilor.
- GR Препоръчва се за поставяне на ваденци.
- SJ Pri nameščanju nalepnice priporočamo.
- GR Συνιστάται για την τοποθέτηση των χαλκομανιών.
- TR Çikartmaların takılması için önerilir.



*

- DE Zur Anbringung der Klarteile empfohlen.
- GB Recommended to fix clear parts.
- FR Recommandé pour fixer les pièces transparentes.
- NL Aanbevolen voor het aanbrengen van transparante delen.
- IT Raccomandato per l'applicazione delle parti trasparenti.
- ES Recomendado para fijar las piezas transparentes.
- PT Recomendado para a aplicação das peças transparentes.
- DK Anbefales til anbringelse af de klare dele.
- NO Anbefales til å feste klare deler.
- SE Rekommenderad för montering av de genomskinliga detaljerna.
- FI Suositellaan läpinäkyvien osien siirtämiseen.
- RU Рекомендуется для крепления прозрачных деталей.
- PL Zalecane do przyklejenia przezroczystych części.
- CZ Doporúčujeme k umiestnení průhledných dílů.
- HU Az átlátszó darabok felhelyezéséhez ajánlható.
- SK Odporúča sa pre umiestnenie čírych dielov.
- RO Recomandat pentru aplicarea pieselor transparente.
- GR Препоръчва се за поставяне на прозрачни части.
- SJ Pri nameščanju prozornih delov priporočamo.
- GR Συνιστάται για την τοποθέτηση των διάφανων μερών.
- TR Şeffaf parçaların takılması için önerilir.

*

- DE Nicht enthalten
- GB Not included
- FR Non fourni
- NL Behoort niet tot de levering
- IT Non incluso
- ES No incluido
- PT Não incluído
- DK Medfølger ikke
- NO Ikke inkludert
- SE Ingår ej
- FI Ei sisällä
- RU Не содержится
- PL Nie wchodzi w zakres dostawy
- CZ Není obsaženo
- HU Nem tartalmazza
- SK Neobsahuje
- RO Nu este inclus
- GR Не се включва в комплекта
- SJ Ni priloženo
- GR Δεν περιλαμβάνεται
- TR İçermiyor

Benötigte Farben / Required colours

- FR Peintures nécessaires
- NL Benodigde kleuren
- IT Colori necessari
- ES Colores necesarios
- PT Cores necessárias
- DK Nødvendige farver
- NO Nødvendige farger
- SE Erforderliga färger
- F Tarvittavat värit
- RU Необходимые краски
- PL Potrzebne kolory
- CZ Potřebné barvy
- HU Szükséges színek
- SK Požadované farby
- RO Culori necesare
- BG Необходими цветове
- SI Potrebne barve
- GR Απαιτούμενα χρώματα
- TR Gerekl renkler



- DE Beispiel: mischen
- GB Example: mixing
- FR Exemple: mélanger
- NL Voorbeeld: mengen
- IT Esempio: mescolare
- ES Ejemplo: mezclar
- PT Exemplo: misturar
- DK Eksempel: blanding
- NO Eksempel: blanding
- SE Exempel: blanda
- F Esimerkki: sekoittaminen
- RU Пример: смешивание
- PL Przykład: mieszać
- CZ Příklad: míchat
- HU Példa: keverés
- SK Příklad: miešanie
- RO Exemplu: amestecare
- BG Пример: смесване
- SI Primer: mešanje
- GR Παράδειγμα: ανάμειξη
- TR Örnek: karıştırma

99

A

- DE Aluminium metallic
- GB Aluminium metallic
- FR Aluminium métallique
- NL Aluminium metallic
- IT Alluminio metallico
- ES Aluminio metálico
- PT Alumínio metálico
- DK Aluminium metallisk
- NO Aluminium metallisk
- SE Aluminium metallisk
- F Alumiini metallinen
- RU Алюминий металлик
- PL Aluminium metaliczny
- CZ Hliníková metalizovaný
- HU Alumínium metál
- SK Hliníková metaliza
- RO Aluminiu metallic
- BG Алюминий металик
- SI Aluminijasta kovinska
- GR Αλουμίνιο μεταλλικό
- TR Alüminyum grisi metalik

302

B

- DE Schwarz seidenmatt
- GB Black silk matt
- FR Noir satiné mat
- NL Zwart zijdemat
- IT Nero opaco satinato
- ES Negro mate satinado
- PT Preto mate sedoso
- DK Sort silkematt
- NO Sort silkematt
- SE Svart sidenmatt
- F Musta silkimatta
- RU Чёрный шелковисто-матовый
- PL Czarny jedwabście matowy
- CZ Černá jemně matný
- HU Fekete, fakóselymes
- SK Čierna hodvábne matný
- RO Negru satinat
- BG Черно коприненоматово
- SI Črna svileni-mat
- GR Μαύρο σατινέ
- TR Siyah ipeksi mat

90

C

- DE Silber metallic
- GB Silver metallic
- FR Argent métallique
- NL Zilver metallic
- IT Argento metallico
- ES Plata metálico
- PT Prata metálico
- DK Sølv metallisk
- NO Sølv metallic
- SE Silver metallic
- F Hopea metallinen
- RU Серебрянный металлик
- PL Srebrny metaliczny
- CZ Stříbrná metalizovaný
- HU Ezüstmetál
- SK Strieborná metaliza
- RO Argintiu metallic
- BG Сребро металик
- SI Srebrna kovinska
- GR Ασημί μεταλλικό
- TR Gümüş rengi metalik

09

D

- DE Anthrazit matt
- GB Anthracite matt
- FR Anthracite mat
- NL Antraciet mat
- IT Antracite opaco
- ES Antracita mate
- PT Antracite mate
- DK Antracitgrå mat
- NO Antrasitt matt
- SE Antracitgrå matt
- F Antrasiitinharmaa matta
- RU Антрацит матовый
- PL Antracyt matowy
- CZ Antracitová šedá matný
- HU Antracit, fénytelen
- SK Čierna uhlová matný
- RO Antracit mat
- BG Антрацит матово
- SI Antracit mat
- GR Γκρι ανθρακί ματ
- TR Antrazit mat

91

E

- DE Eisen metallic
- GB Iron metallic
- FR Fer métallique
- NL Ijzer metallic
- IT Ferro metallico
- ES Acero metálico
- PT Aço metálico
- DK Stål metallisk
- NO Jern metallic
- SE Stål metallic
- F Teräs metallinen
- RU Сталь металлик
- PL Grafit metaliczny
- CZ Ocelová metalizovaný
- HU Acélmetél
- SK Ocelová metaliza
- RO Fier metallic
- BG Желязо металик
- SI Železna kovinska
- GR Χρώμα σιδήρου μεταλλικό
- TR Metalik metalik

07

F

- DE Schwarz glänzend
- GB Black gloss
- FR Noir brillant
- NL Zwart glanzend
- IT Nero lucido
- ES Negro brillante
- PT Preto brilhante
- DK Sort blank
- NO Sort glansende
- SE Svart blank
- F Musta kiiltävä
- RU Чёрный глянец
- PL Czarny błyszczący
- CZ Černá lesklý
- HU Fekete, fényes
- SK Čierna lesklý
- RO Negru-strălucitor
- BG Черно гланцово
- SI Črna sijoca
- GR Μαύρο γυαλιστερό
- TR Siyah parlak

50%

302

G

378

50%

- DE Schwarz seidenmatt
- GB Black silk matt
- FR Noir satiné mat
- NL Zwart zijdemat
- IT Nero opaco satinato
- ES Negro mate satinado
- PT Preto mate sedoso
- DK Sort silkematt
- NO Sort silkematt
- SE Svart sidenmatt
- F Musta silkimatta
- RU Чёрный шелковисто-матовый
- PL Czarny jedwabście matowy
- CZ Tmavá šedá jemně matný
- HU Fekete, fakóselymes
- SK Tmavo sivá hodvábne matný
- RO Negru satinat
- BG Черно коприненоматово
- SI Črna svileni-mat
- GR Μαύρο σατινέ
- TR Siyah ipeksi mat
- DE Dunkelgrau seidenmatt
- GB Dark grey silk matt
- FR Gris foncé satiné mat
- NL Donkergrijs zijdemat
- IT Grigio scuro opaco satinato
- ES Gris oscuro mate satinado
- PT Cinza escuro mate sedoso
- DK Mørkegrå silkematt
- NO Mørk grå silkematt
- SE Mörkgrå sidenmatt
- F Tummanharmaa silkimatta
- RU Тёмно-серый шелковисто-матовый
- PL Ciemnoszary jedwabście matowy
- CZ Tmavá šedá jemně matný
- HU Sötétszürke, fakóselymes
- SK Tmavo sivá hodvábne matný
- RO Gri-inchis satinat
- BG Тъмносиво коприненоматово
- SI Temno-siva svileni-mat
- GR Γκρι σκούρο σατινέ
- TR Koyu gri ipeksi mat

378

H

- DE Dunkelgrau seidenmatt
- GB Dark grey silk matt
- FR Gris foncé satiné mat
- NL Donkergrijs zijdemat
- IT Grigio scuro opaco satinato
- ES Gris oscuro mate satinado
- PT Cinza escuro mate sedoso
- DK Mørkegrå silkematt
- NO Mørk grå silkematt
- SE Mörkgrå sidenmatt
- F Tummanharmaa silkimatta
- RU Тёмно-серый шелковисто-матовый
- PL Ciemnoszary jedwabście matowy
- CZ Tmavá šedá jemně matný
- HU Sötétszürke, fakóselymes
- SK Tmavo sivá hodvábne matný
- RO Gri-inchis satinat
- BG Тъмносиво коприненоматово
- SI Temno-siva svileni-mat
- GR Γκρι σκούρο σατινέ
- TR Koyu gri ipeksi mat

310

I

- DE Lufthansa-Gelb seidenmatt
- GB Lufthansa yellow silk matt
- FR Jaune Lufthansa satiné mat
- NL Lufthansa-geel zijdemat
- IT Giallo Lufthansa opaco satinato
- ES Amarillo mate satinado
- PT Amarelo mate sedoso
- DK Lufthansagul silkematt
- NO Gul silkematt
- SE Lufthansagul sidenmatt
- FI Keltainen silkkimatta
- RU Люфтганза жёлтый шелковисто-матовый
- PL Żółty Lufthansa jedwabście matowy
- CZ Žlutá jemně matný
- HU Lufthansa sárga, fakóselymes
- SK Žltá hodvábné matný
- NO Galben satinat
- RO Жёлто Луфганза коприненоматово
- SI Lufthansa-rumena svilenlo-mat
- GR Κίτρινο Lufthansa σατινέ
- TR Sari ipeksi mat

04

J

- DE Weiß glänzend
- GB White gloss
- FR Blanc brillant
- NL Wit glanzend
- IT Bianco lucido
- ES Blanco brillante
- PT Branco brilhante
- DK Hvid blank
- NO Hvit glansende
- SE Vit blank
- FI Valkoinen kiiltävä
- RU Белый гляцевый
- PL Biały błyszczący
- CZ Bílá lesklý
- HU Fehér, fényes
- SK Biela lesklý
- NO Alb strålucitor
- RO Бяло глаццово
- SI Bela sijoča
- GR Ασπρο γυαλιστερό
- TR Beyaz parlak

12

K

- DE Gelb glänzend
- GB Yellow gloss
- FR Jaune brillant
- NL Geel glanzend
- IT Giallo lucido
- ES Amarillo brillante
- PT Amarelo brilhante
- DK Gul blank
- NO Gul glansende
- SE Gul blank
- FI Keltainen kiiltävä
- RU Жёлтый гляцевый
- PL Żółty błyszczący
- CZ Žlutá lesklý
- HU Sárga, fényes
- SK Žltá lesklý
- NO Galben strålucitor
- RO Жълто глаццово
- SI Rumena sijoča
- GR Κίτρινο γυαλιστερό
- TR Sari parlak

301

L

- DE Weiß seidenmatt
- GB White silk matt
- FR Blanc satiné mat
- NL Wit zijdemat
- IT Bianco opaco satinato
- ES Blanco mate satinado
- PT Branco mate sedoso
- DK Hvid silkematt
- NO Hvit silkematt
- SE Vit sidenmatt
- FI Valkoinen silkkimatta
- RU Белый шелковисто-матовый
- PL Biały jedwabście matowy
- CZ Bílá jemně matný
- HU Fehér, fakóselymes
- SK Biela hodvábné matný
- NO Alb satinat
- RO Бяло коприненоматово
- SI Bela svilenlo-mat
- GR Ασπρο σατινέ
- TR Beyaz ipeksi mat

88

M

- DE Ocker matt
- GB Ochre matt
- FR Ocre mat
- NL Oker mat
- IT Ocra opaco
- ES Ocre mate
- PT Ocre mate
- DK Okkerbrun mat
- NO Okerbrun matt
- SE Ockrabrun matt
- FI Okranruskea matta
- RU Охра матовый
- PL Ochra matowy
- CZ Okr hnědý matný
- HU Okker, fénytelen
- SK Okrová matný
- NO Ocru mat
- RO Охра матово
- SI Oker mat
- GR Όχρα ματ
- TR Toprak rengi mat

85

N

- DE Braun matt
- GB Brown matt
- FR Brun mat
- NL Bruin mat
- IT Marrone opaco
- ES Marrón mate
- PT Castanho mate
- DK Brun mat
- NO Brun matt
- SE Brun matt
- FI Ruskea matta
- RU Коричневый матовый
- PL Brązowy matowy
- CZ Hnědá matný
- HU Barna, fénytelen
- SK Hnedá matný
- NO Maro mat
- RO Кафяво матово
- SI Rjava mat
- GR Καφέ ματ
- TR Kahve mat

80%

84

O

01

20%

- DE Lederbraun matt
- GB Leather brown matt
- FR Brun cuir mat
- NL Lederbruin mat
- IT Marrone pelle opaco
- ES Marrón cuero mate
- PT Castanho couro mate
- DK Læderbrun mat
- NO Lærbrun matt
- SE Läderbrun matt
- FI Nahanuskea matta
- RU Коричневая кожа матовый
- PL Skórzanobrazowy matowy
- CZ Kožená hnědá matný
- HU Bőrszínű, fénytelen
- SK Kožená hnedá matný
- NO Maro pielos mat
- RO Кафява кожа матово
- SI Ušnjenjo-rjava mat
- GR Καφέ σκούρο ματ
- TR Deri kahvesi mat

+

- DE Farblos glänzend
- GB Clear gloss
- FR Incoloro brillant
- NL Kleurloos glanzend
- IT Incoloro lucido
- ES Incoloro brillante
- PT Verniz brilhante
- DK Klarlak blank
- NO Klar glansende
- SE Klarlack blank
- FI Värítön kiiltävä
- RU Бесцветный гляцевый
- PL Przejrzysty błyszczący
- CZ Bezbarvá lesklý
- HU Színtelen, fényes
- SK Priehľadný lesklý
- NO Transparent strålucitor
- RO Безцветно глаццово
- SI Brezbarvna sijoča
- GR Διάφανο γυαλιστερό
- TR Renksiz parlak

314

P

- DE Beige seidenmatt
- GB Beige silk matt
- FR Beige satiné mat
- NL Beige zijdemat
- IT Beige opaco satinato
- ES Beige mate satinado
- PT Beige mate sedoso
- DK Beige silkematt
- NO Beige silkematt
- SE Beige sidenmatt
- FI Beige silkkimatta
- RU Бежевый шелковисто-матовый
- PL Beżowy jedwabście matowy
- CZ Běžová jemně matný
- HU Bézs, fakóselymes
- SK Běžová hodvábné matný
- NO Bej satinat
- RO Бежово коприненоматово
- SI Bež svilenlo-mat
- GR Μπεζ σατινέ
- TR Bej ipeksi mat

382

Q

- DE Holzbraun seidenmatt
- GB Wood brown silk matt
- FR Brun bois satiné mat
- NL Houtbruin zijdemat
- IT Marrone legno opaco satinato
- ES Marrón madera mate satinado
- PT Castanho madeira mate sedoso
- DK Træbrun silkematt
- NO Trebrun silkematt
- SE Tråbrun sidenmatt
- FI Puunruskea silkkimatta
- RU Древесно-коричневый шелковисто-матовый
- PL Brązowy w odcieniu drewna jedwabście matowy
- CZ Dřevěná hnědá jemně matný
- HU Fa barna, fakóselymes
- SK Drevená hnedá hodvábné matný
- NO Maro lemnos satinat
- RO Дървеснокафяво коприненоматово
- SI Lesno-rjava svilenlo-mat
- GR Καφέ ανοιχτό σατινέ
- TR Ahşap rengi ipeksi mat

730

R

- DE Orange klar
- GB Orange clear
- FR Orange clair
- NL Oranje helder
- IT Arancio chiaro
- ES Naranja claro
- PT Laranja transparente
- DK Orange klar
- NO Oransje klar
- SE Oransje klar
- FI Oranssi kirkas
- RU Оранжевый прозрачный
- PL Pomarańczowy przezroczysty
- CZ Oranžová bezbarvý
- HU Narancs, világos
- SK Oranžová číry
- NO Oranj curat
- RO Оранжево бистро
- SI Oranžna čista
- GR Πορτοκαλί διάφανο
- TR Turuncu canlı

731

S

- DE Rot klar
- GB Red clear
- FR Rouge clair
- NL Rood helder
- IT Rosso chiaro
- ES Rojo claro
- PT Vermelho transparente
- DK Rødbrun klar
- NO Rød klar
- SE Rødbrun klar
- FI Punainen kirkas
- RU Красный прозрачный
- PL Czerwony przezroczysty
- CZ Červená bezbarvý
- HU Piros, világos
- SK Červená číry
- NO Roðu curat
- RO Червено бистро
- SI Rdeča čista
- GR Κόκκινο διάφανο
- TR Kırmızı canlı

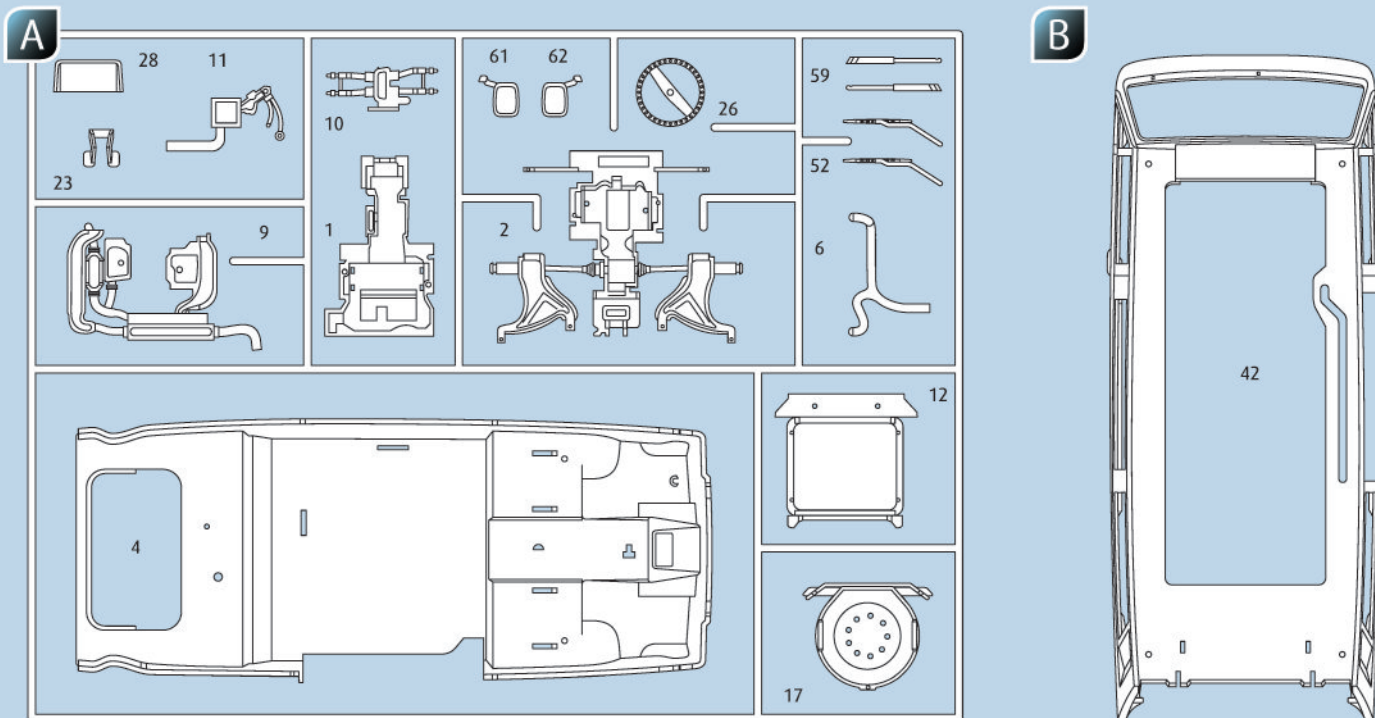

Ⓞ Nicht benötigte Teile
 Ⓞ Parts not used.
 Ⓞ Pièces non utilisées.
 Ⓞ Niet benodigde onderdelen.
 Ⓞ Parti non necessarie.
 Ⓞ Piezas no utilizadas.
 Ⓞ Peças não utilizadas.

Ⓞ Dele der ikke skal bruges.
 Ⓞ Deler som ikke er nødvendige.
 Ⓞ Ej nödvändiga delar.
 Ⓞ Tarpeettomat osat.
 Ⓞ Неиспользуемые детали.
 Ⓞ Niepotrzebne części.
 Ⓞ Nepotřebné díly.

Ⓞ Szükségtelen alkatrészek.
 Ⓞ Nepotrebne diely.
 Ⓞ Pieše care nu sunt necesare.
 Ⓞ Ненужни детали.
 Ⓞ Nepotrebni deli.
 Ⓞ Μη χρησιμοποιούμενα μέρη.
 Ⓞ Gerekl olmayan parçalar.

Ⓞ Kundenservice: www.revell-service.de oder **Revell GmbH, Abteilung X, Henschelstr. 20-30, D-32257 Bünde** (nur für DE, AT, NL, BE, LU, ES, IT, PL, US, CA). Für alle übrigen Länder kontaktieren Sie ausschließlich Ihren Händler oder Distributeur.

Ⓞ Customer Service: www.revell-service.de/en or **Carrera Revell UK LTD, Unit 10, Old Airfield Industrial Estate, Cheddington Lane, Tring HP23 4QR, United Kingdom** (only for United Kingdom and Ireland). For all other countries please contact your dealer or distributor only.

Ⓞ Customer Service: www.revell-service.de/en or **Revell GmbH, Department X, Henschelstr. 20-30, D-32257 Bünde, Germany** (only for DE, AT, NL, BE, LU, ES, IT, PL, US, CA). For all other countries please contact your dealer or distributor only.

Ⓞ Service clientèle: www.revell-service.de/fr (uniquement pour la France). Pour tous les autres pays, veuillez contacter votre revendeur ou distributeur uniquement.

Ⓞ Klantenservice: www.revell-service.de of **Revell GmbH, Abteilung X, Henschelstr. 20-30, D-32257 Bünde** (alleen voor DE, AT, NL, BE, LU, ES, IT, PL, US, CA). Voor alle andere landen kunt u alleen contact opnemen met uw dealer of distributeur.

Ⓞ Servicio al cliente: www.revell-service.de o **Revell GmbH, Abteilung X, Henschelstr. 20-30, D-32257 Bünde** (sólo para DE, AT, NL, BE, LU, ES, IT, PL, US, CA). Para todos los demás países, por favor, póngase en contacto con su proveedor o distribuidor solamente.

Ⓞ Servizio clienti: www.revell-service.de o **Revell GmbH, Abteilung X, Henschelstr. 20-30, D-32257 Bünde** (solo per DE, AT, NL, BE, LU, ES, IT, PL, US, CA). Per tutti gli altri paesi si prega di contattare esclusivamente il proprio rivenditore o distributore.

Ⓞ Serviço de apoio ao cliente: www.revell-service.de ou **Revell GmbH, Abteilung X, Henschelstr. 20-30, D-32257 Bünde** (apenas para DE, AT, NL, BE, LU, ES, IT, PL, US, CA). Para todos os outros países, contacte apenas o seu revendedor ou distribuidor.

Ⓞ Kundenservice: www.revell-service.de eller **Revell GmbH, Abteilung X, Henschelstr. 20-30, D-32257 Bünde** (kun for DE, AT, NL, BE, LU, ES, IT, PL, US, CA). For alle øvrige lande bedes du udelukkende kontakte din forhandler eller distributor.

Ⓞ Kundenservice: www.revell-service.de eller **Revell GmbH, Abteilung X, Henschelstr. 20-30, D-32257 Bünde** (kun for DE, AT, NL, BE, LU, ES, IT, PL, US, CA). For alle andre land gjelder at all kontakt skal skje via din forhandler eller distributør.

Ⓞ Kundtjänst: www.revell-service.de eller **Revell GmbH, Abteilung X, Henschelstr. 20-30, D-32257 Bünde** (endast för DE, AT, NL, BE, LU, ES, IT, PL, US, CA). För övriga länder var god kontakta återförsäljaren eller distributören.

Ⓞ Asiakaspalvelu: www.revell-service.de tai **Revell GmbH, Abteilung X, Henschelstr. 20-30, D-32257 Bünde** (vain DE, AT, NL, BE, LU, ES, IT, PL, US, CA). Muiden maiden kohdalla ota yhteyttä paikalliseen jälleenmyyjään tai jakelijaan.

Ⓞ Служба поддержки клиентов: www.revell-service.de или **Revell GmbH, Abteilung X, Henschelstr. 20-30, D-32257 Bünde** (только для DE, AT, NL, BE, LU, ES, IT, PL, US, CA). Клиентам из других стран следует обращаться исключительно к своему поставщику или дистрибьютору.

Ⓞ Dział obsługi klienta: www.revell-service.de lub **Revell GmbH, Abteilung X, Henschelstr. 20-30, D-32257 Bünde** (tylko dla DE, AT, NL, BE, LU, ES, IT, PL, US, CA). We wszystkich pozostałych krajach należy kontaktować się wyłącznie ze sprzedawcą lub dystrybutorem.

Ⓞ Zákaznický servis: www.revell-service.de nebo **Revell GmbH, Abteilung X, Henschelstr. 20-30, D-32257 Bünde** (pouze pro DE, AT, NL, BE, LU, ES, IT, PL, US, CA). Pro všechny ostatní země kontaktujte výlučně svého obchodníka nebo prodejce.

Ⓞ Ügyfélszolgálat: www.revell-service.de vagy **Revell GmbH, Abteilung X, Henschelstr. 20-30, D-32257 Bünde** (csak DE, AT, NL, BE, LU, ES, IT, PL, US, CA országok esetében). Az egyéb országok esetének kizárólag kereskedőjével, vagy forgalmazójával vegye fel a kapcsolatot.

Ⓞ Zákaznický servis: www.revell-service.de alebo **Revell GmbH, Abteilung X, Henschelstr. 20-30, D-32257 Bünde** (iba pre DE, AT, NL, BE, LU, ES, IT, PL, US, CA). Pre všetky ostatné krajiny kontaktujte výlučne svojho obchodníka alebo predajcu.

Ⓞ Serviciul clienți www.revell-service.de sau **Revell GmbH, Abteilung X, Henschelstr. 20-30, D-32257 Bünde** (doar pentru DE, AT, NL, BE, LU, ES, IT, PL, US, CA). Pentru toate celelalte țări contactați doar comerciantul dvs. sau distribuitorul.

Ⓞ Отдел за обслужване на клиенти: www.revell-service.de или **Revell GmbH, Abteilung X, Henschelstr. 20-30, D-32257 Bünde** (само за DE, AT, NL, BE, LU, ES, IT, PL, US, CA). За всички останали държави се свързвайте само с Вашия дилър или дистрибутор.

Ⓞ Služba za pomoć strankam: www.revell-service.de ali **Revell GmbH, Abteilung X, Henschelstr. 20-30, D-32257 Bünde** (samo za DE, AT, NL, BE, LU, ES, IT, PL, US, CA). Za vse ostale države se obrnite samo na prodajalca ali distributerja.

Ⓞ Τμήμα εξυπηρέτησης πελατών: www.revell-service.de ή **Revell GmbH, Abteilung X, Henschelstr. 20-30, D-32257 Bünde** (μόνο για DE, AT, NL, BE, LU, ES, IT, PL, US, CA). Για όλες τις άλλες χώρες επικοινωνήστε αποκλειστικά με τον έμπορο ή τον αντιπρόσωπο της περιοχής σας.

Ⓞ Müşteri hizmetleri: www.revell-service.de veya **Revell GmbH, Abteilung X, Henschelstr. 20-30, D-32257 Bünde** (sadece DE, AT, NL, BE, LU, ES, IT, PL, ABD, CA için). Tüm diğer ülkeler için sadece satıcınıza veya distribütörünüze başvurun.

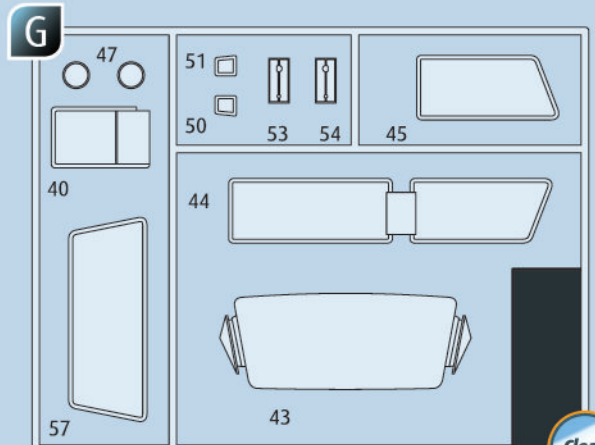
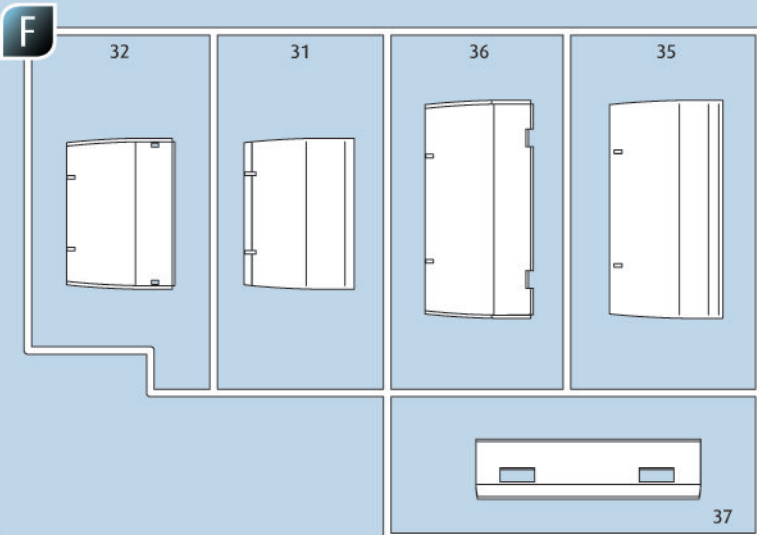
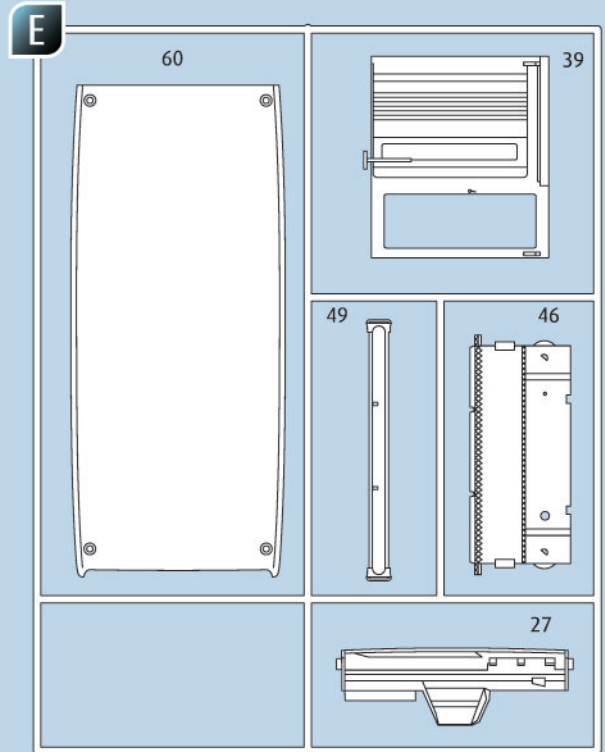
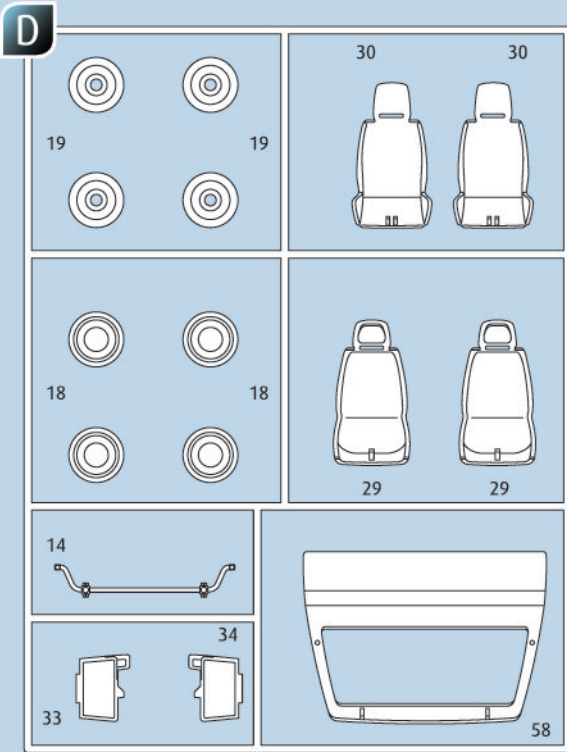
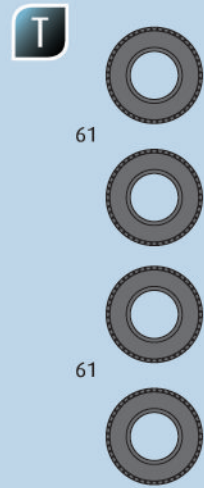
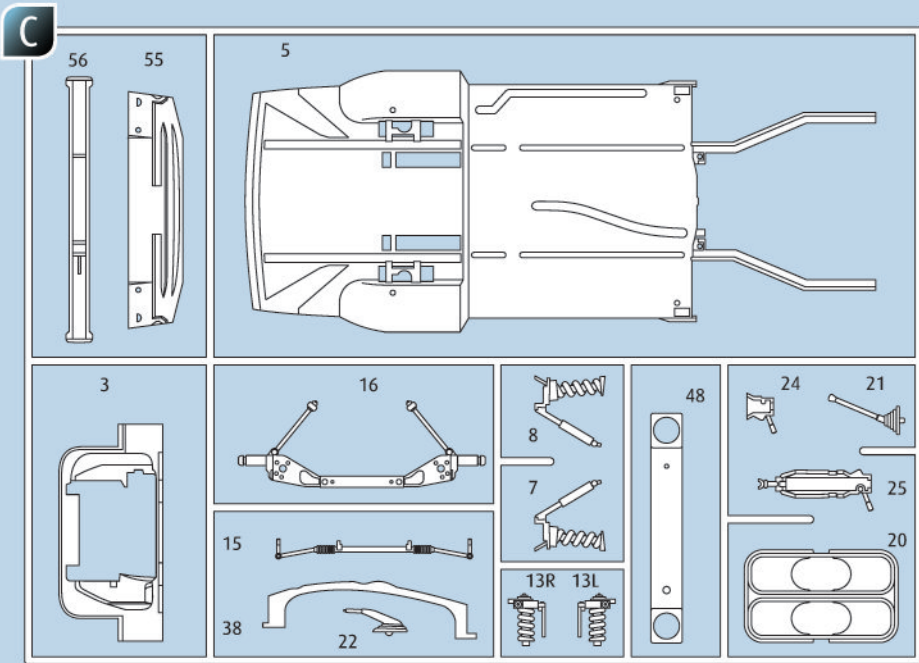

1

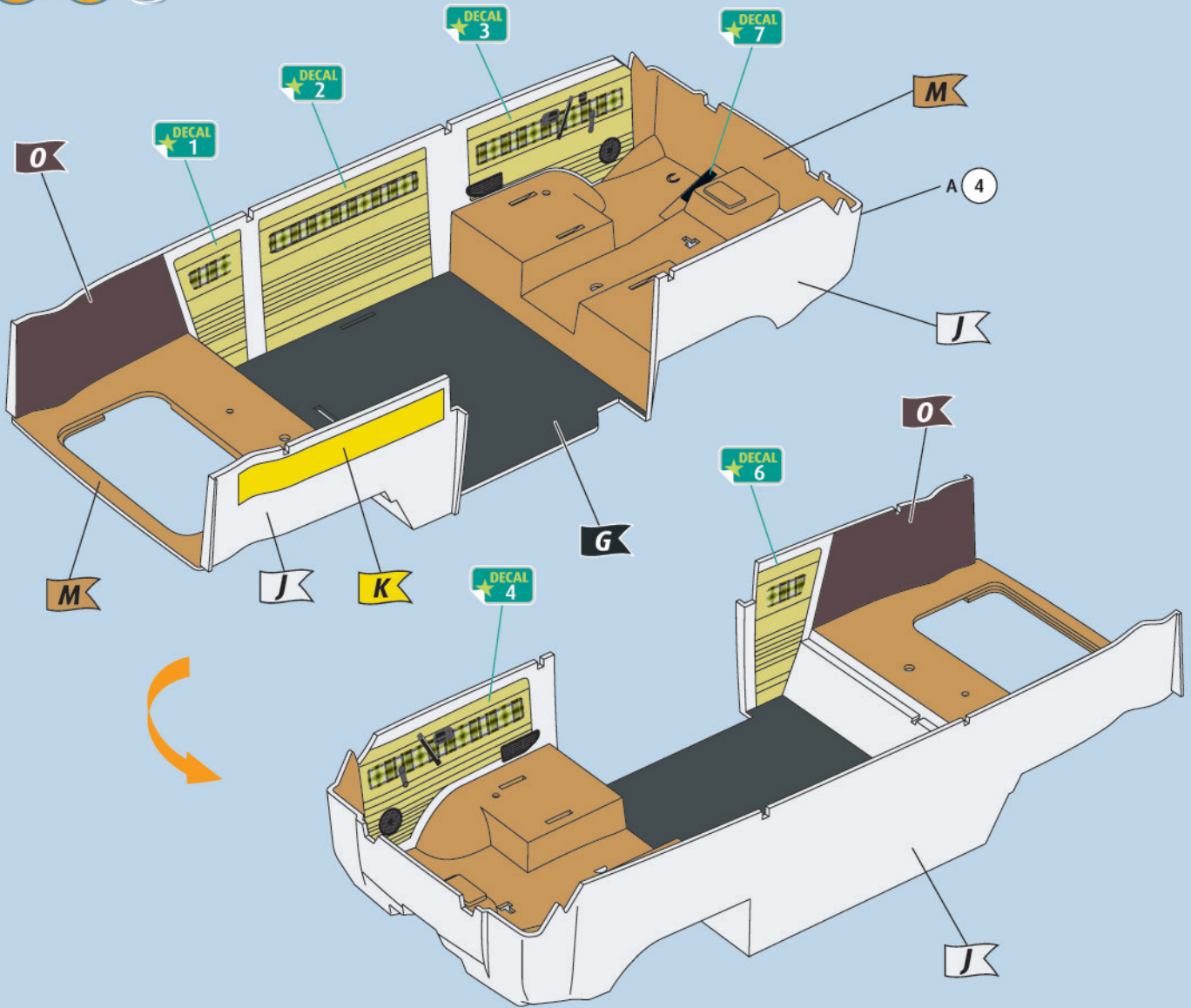

2

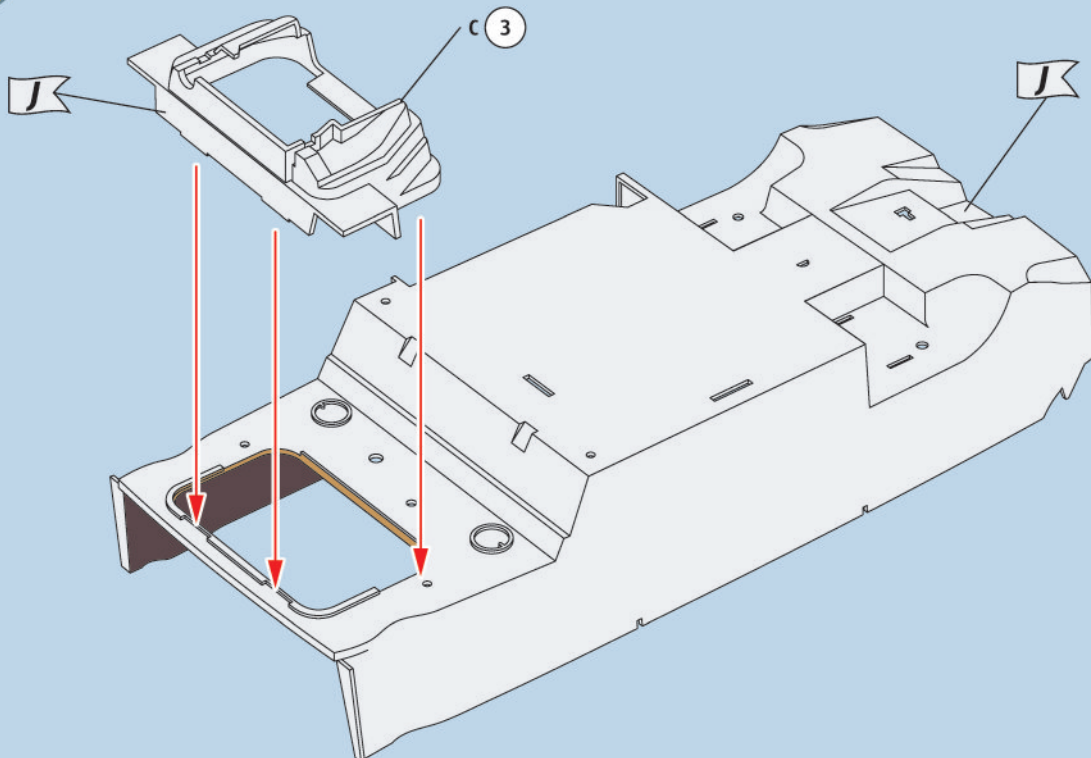

3  

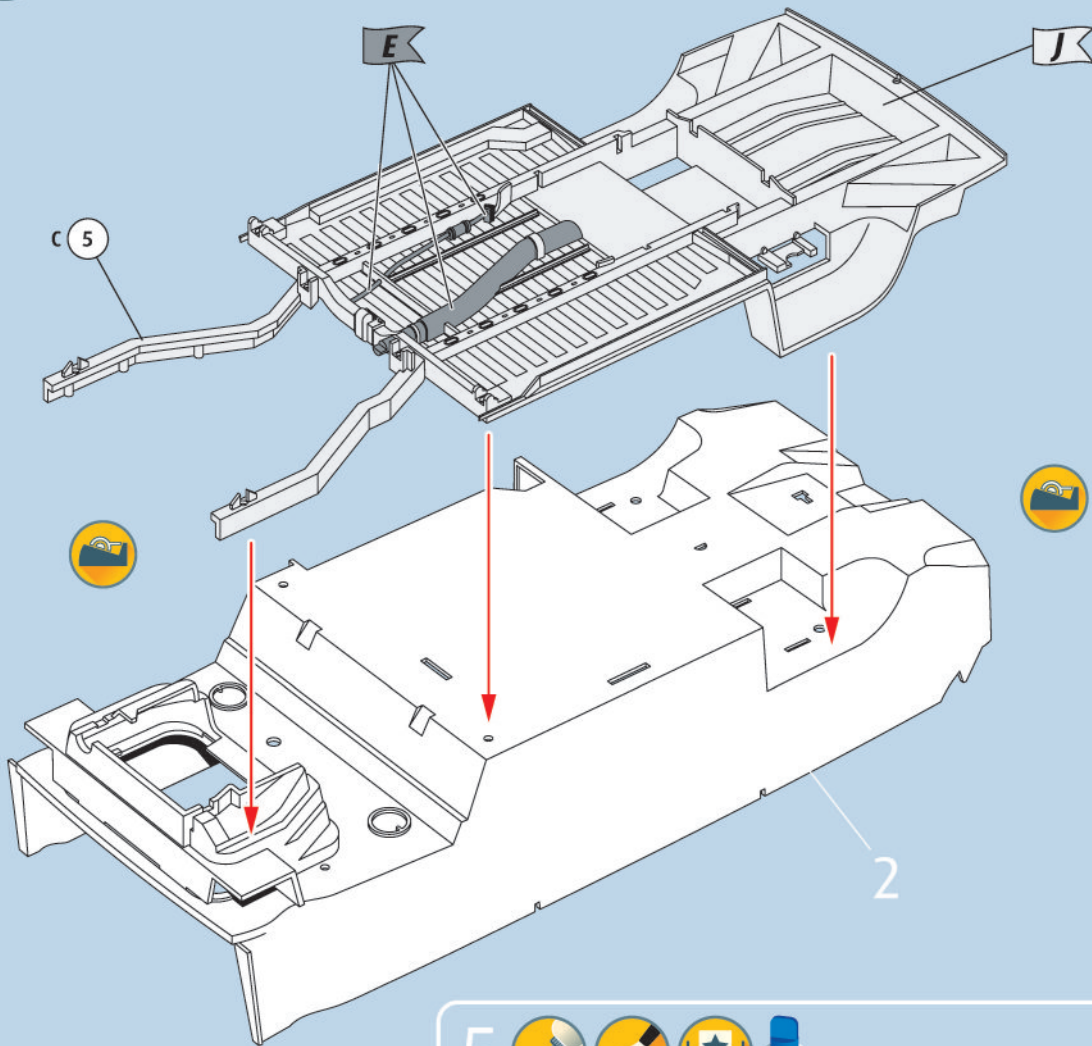

4  

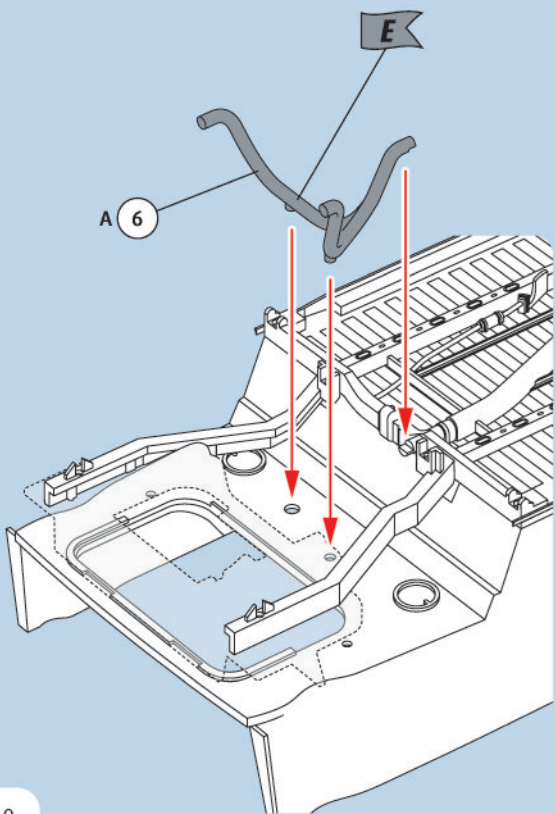

5    

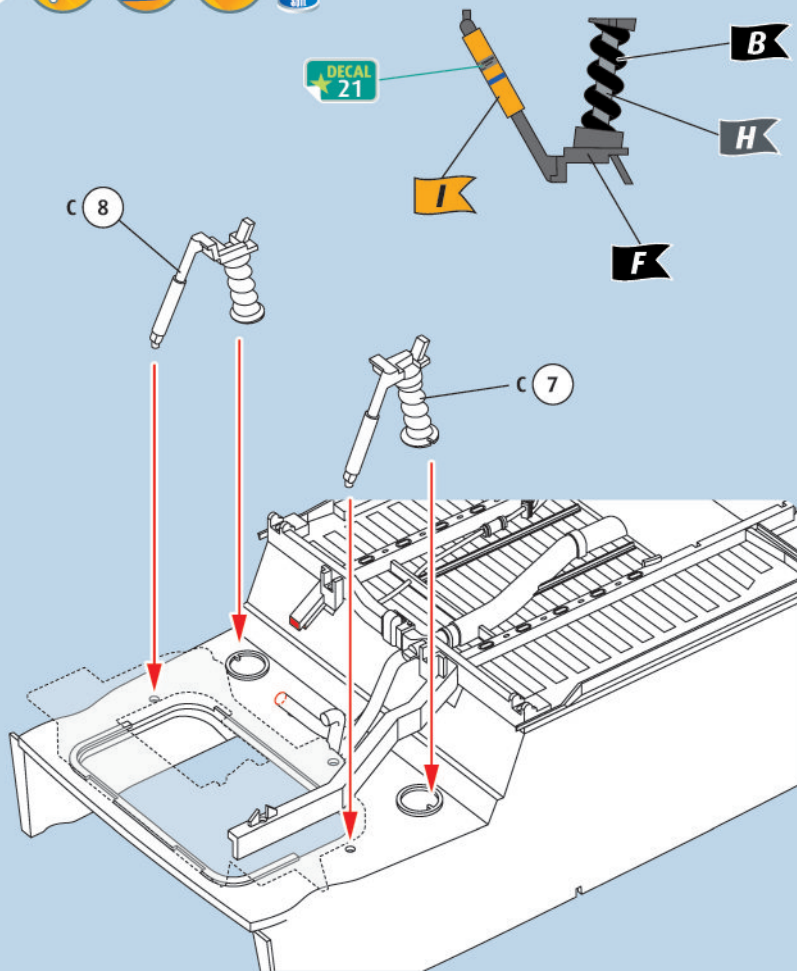

6

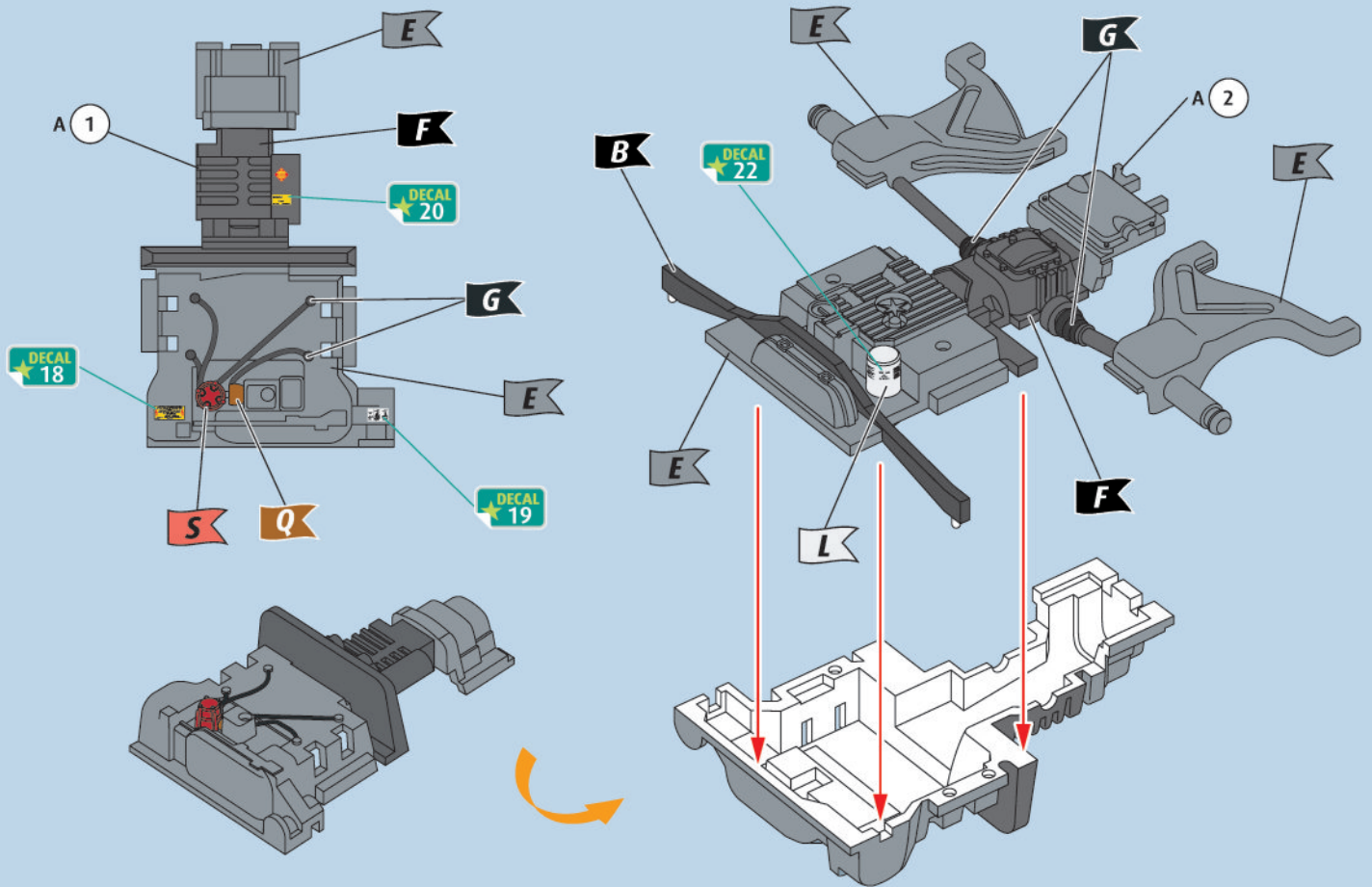

7

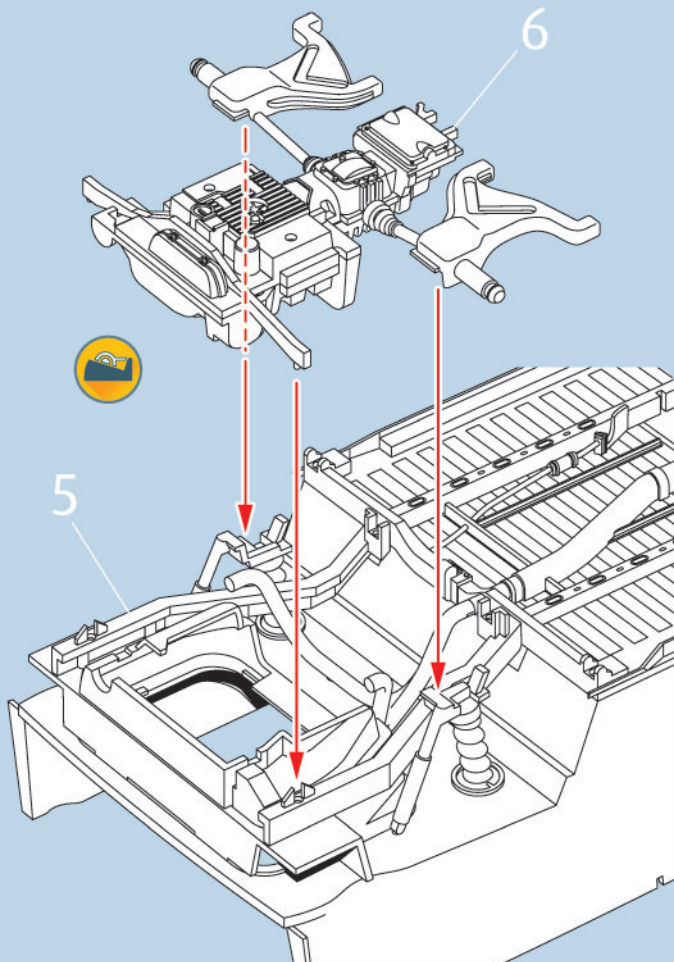

8

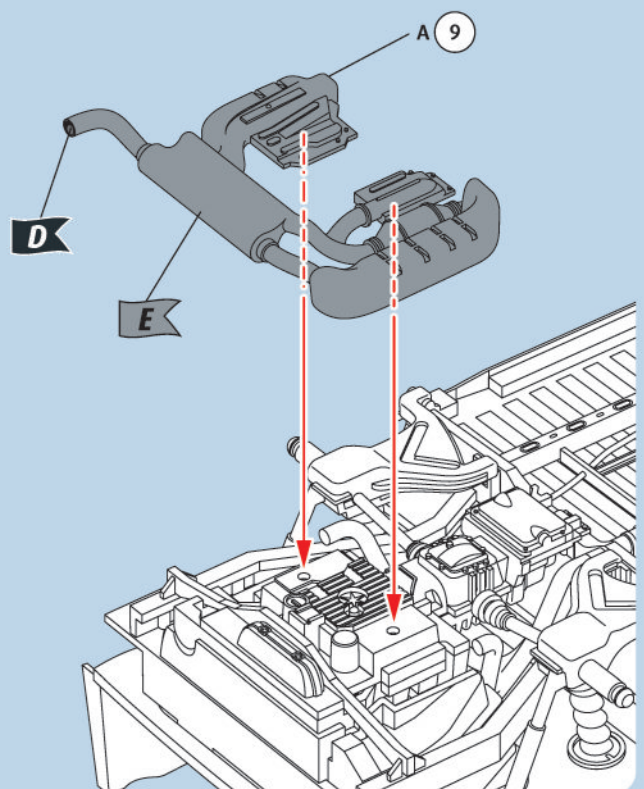

9  

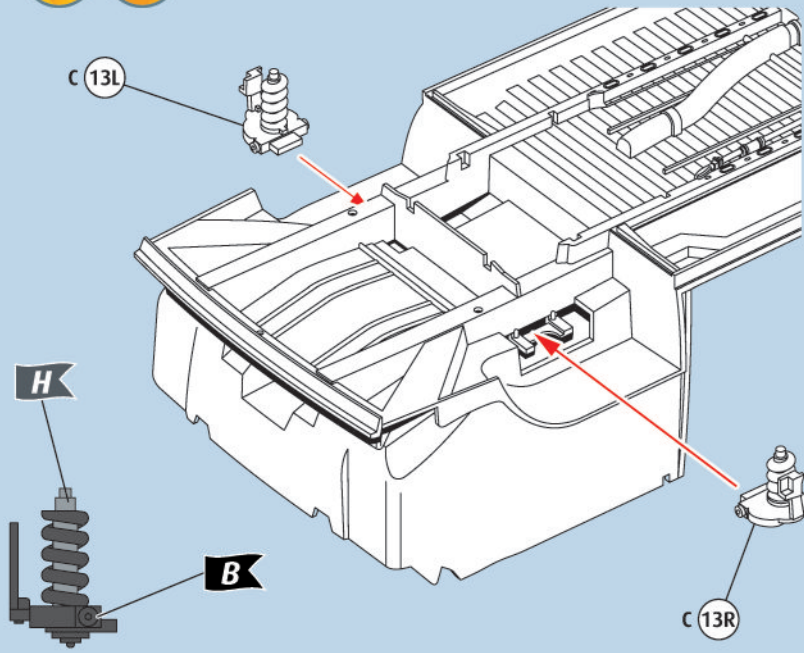

10  

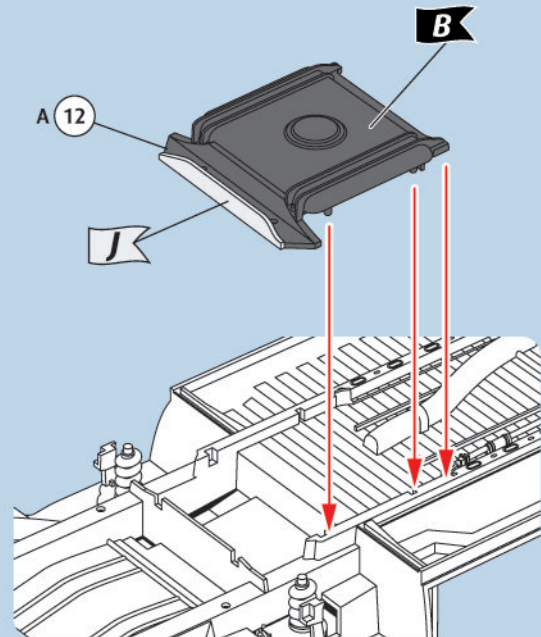

11  

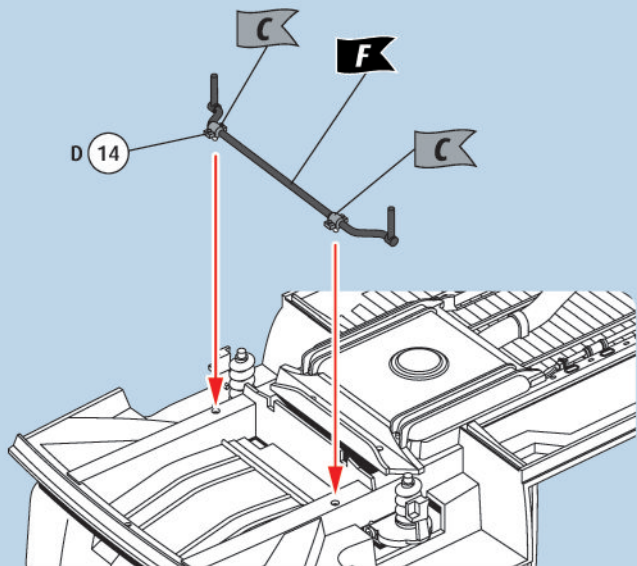

12  

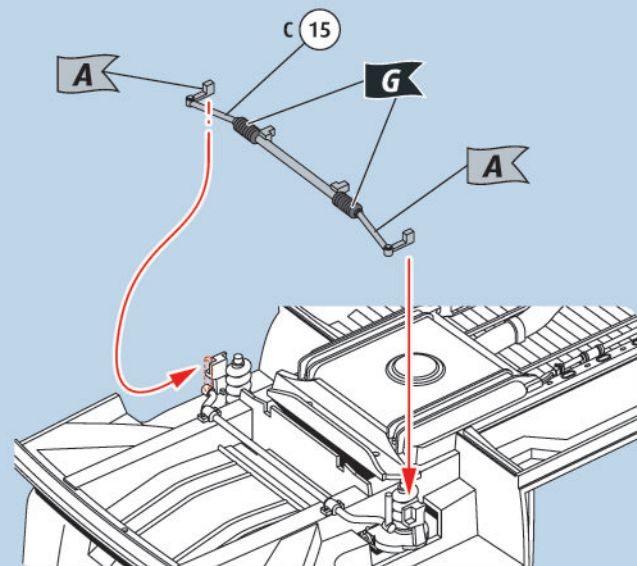

13  

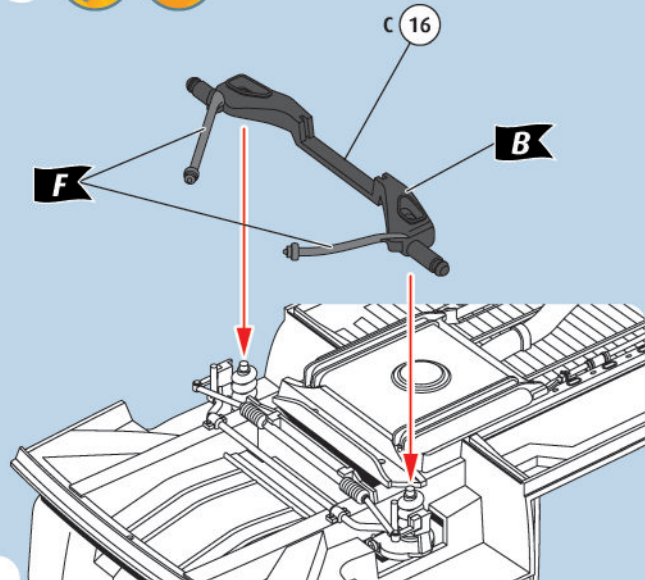

14  

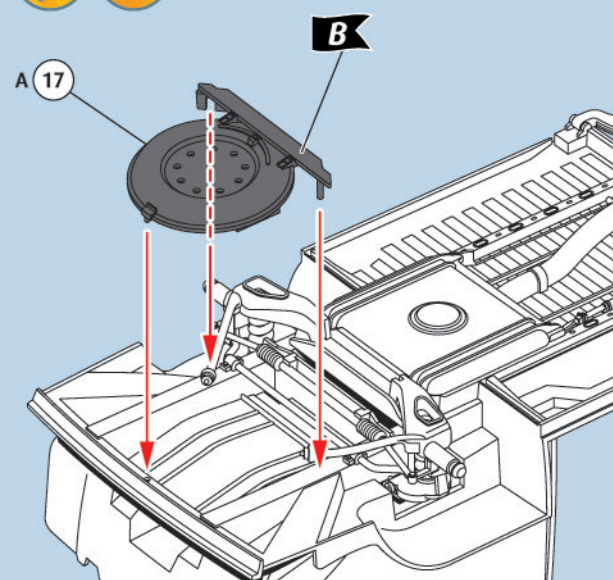

15

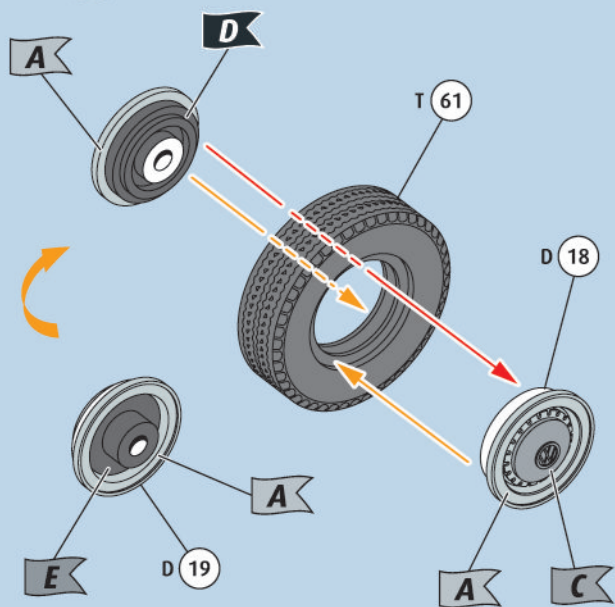

16

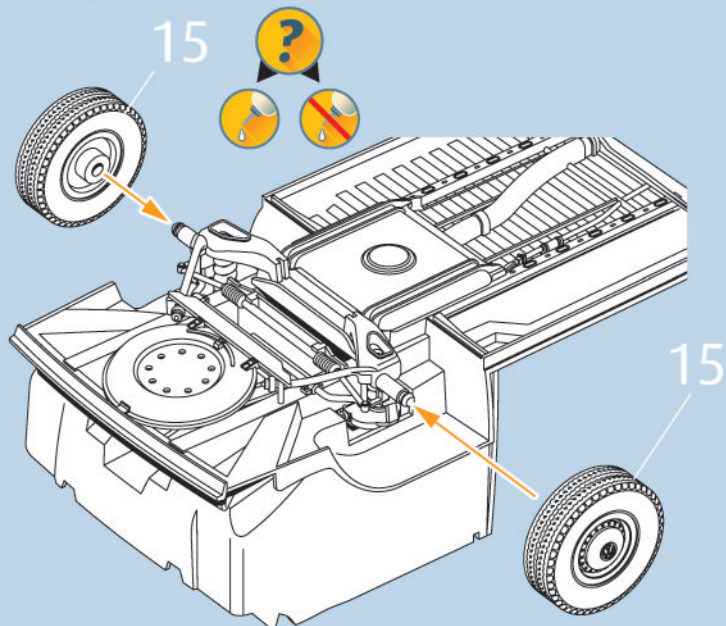

17

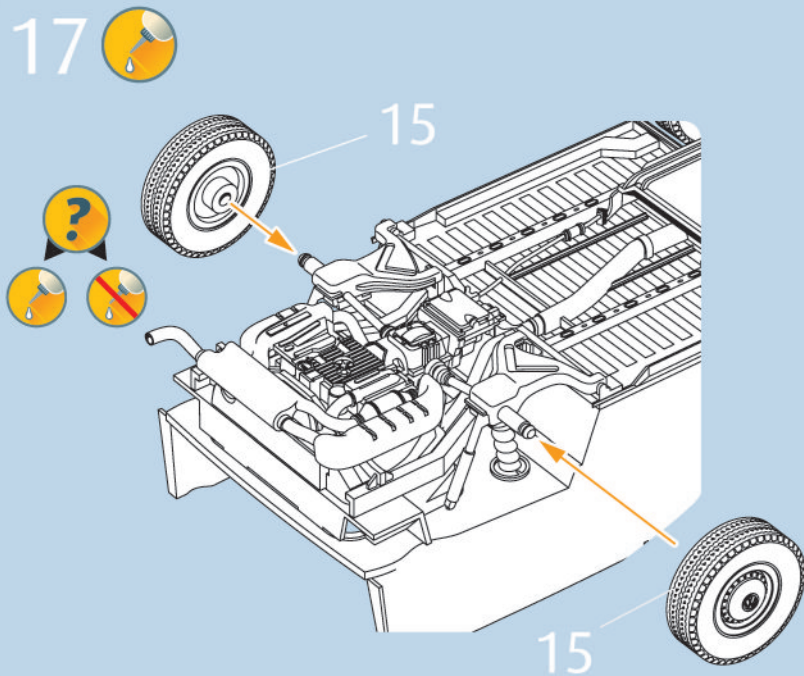

18

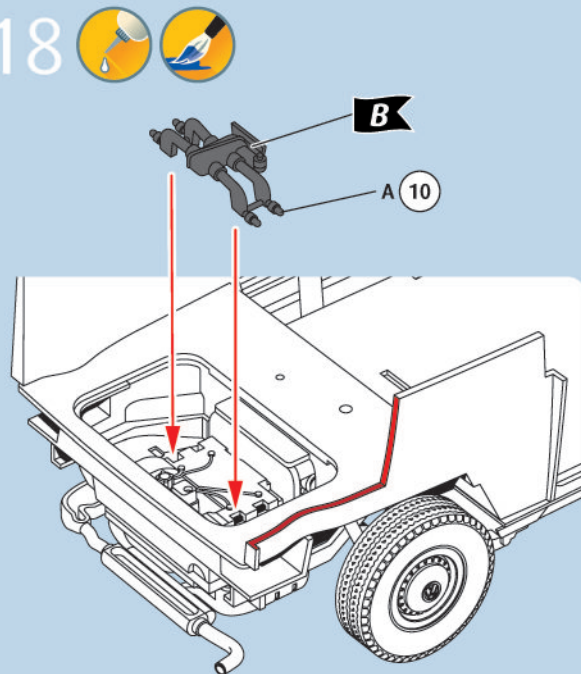

19

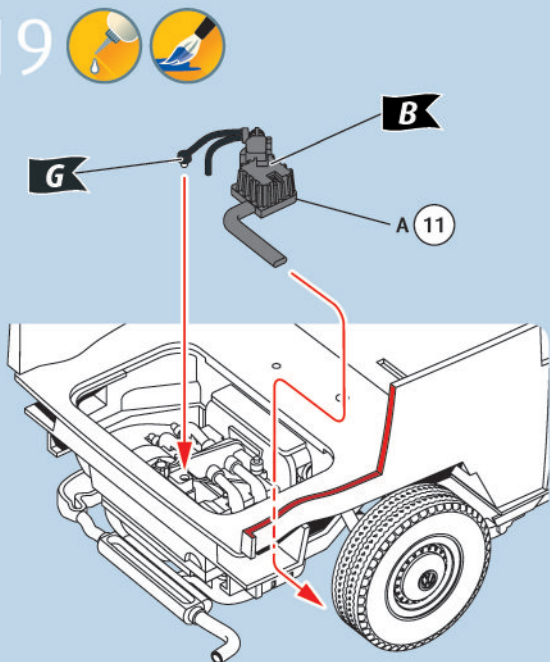

20

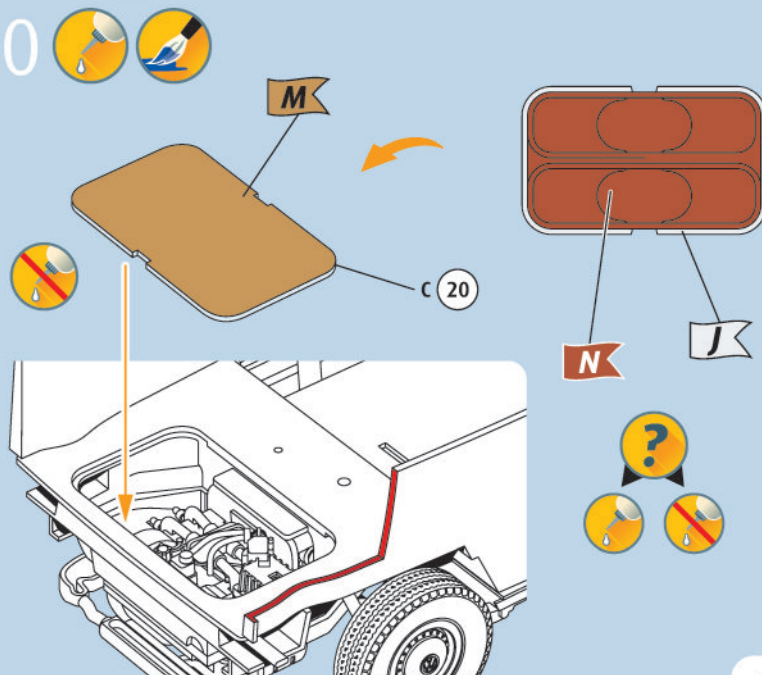

21

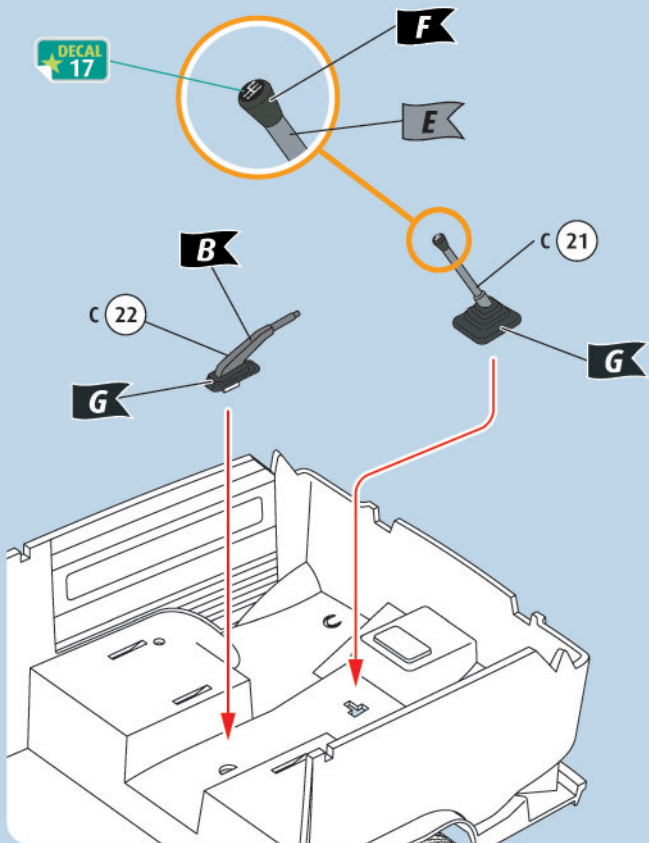

22

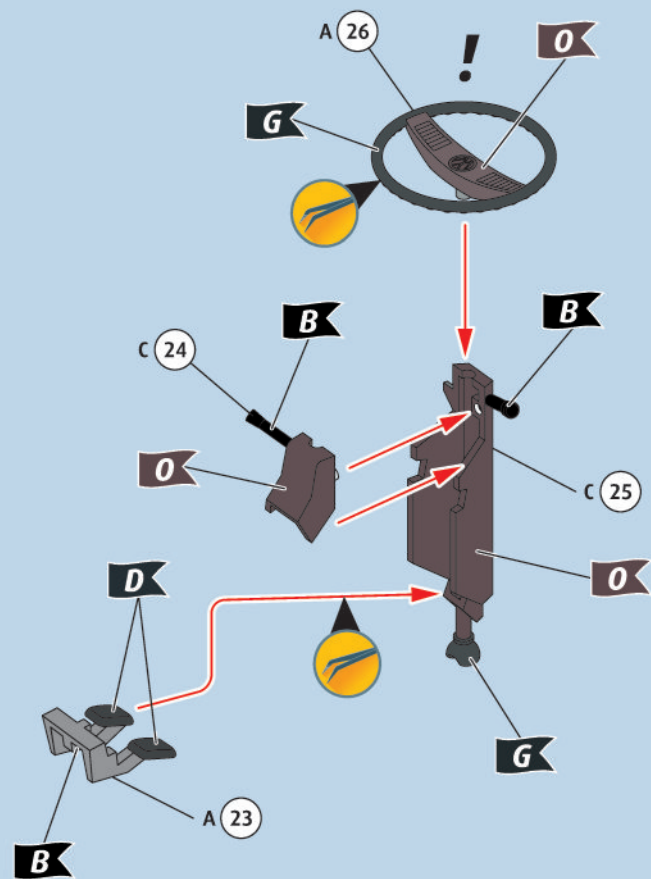

23

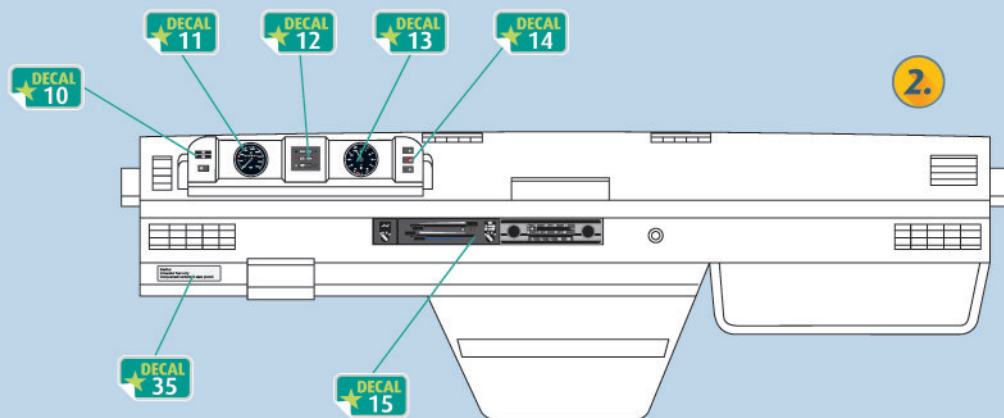
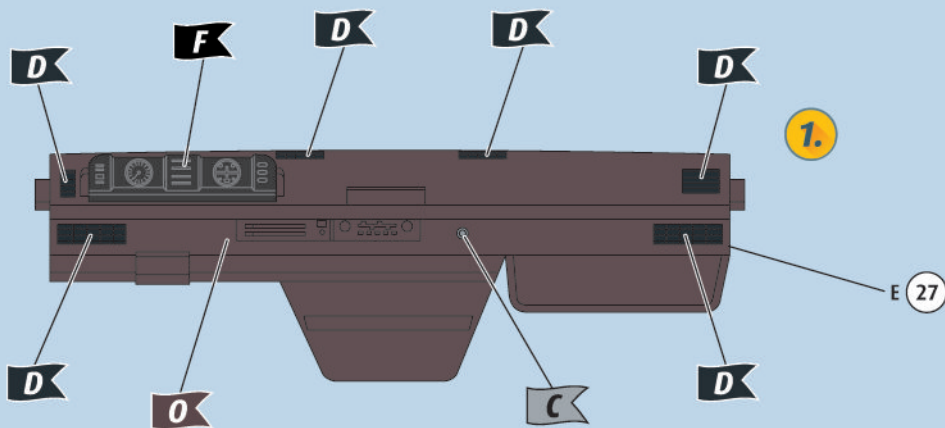

24

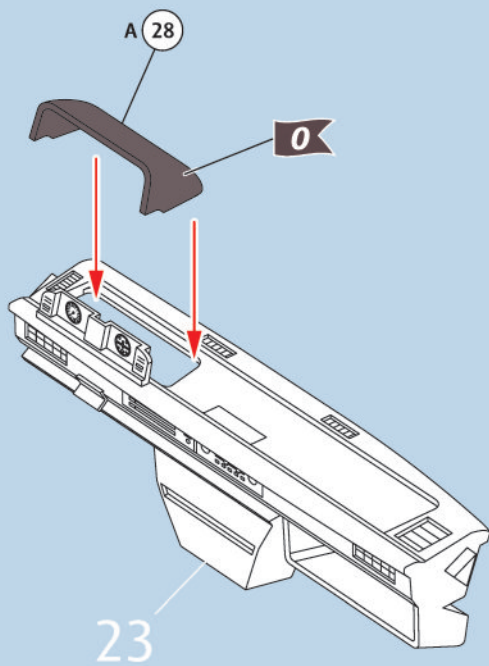

25

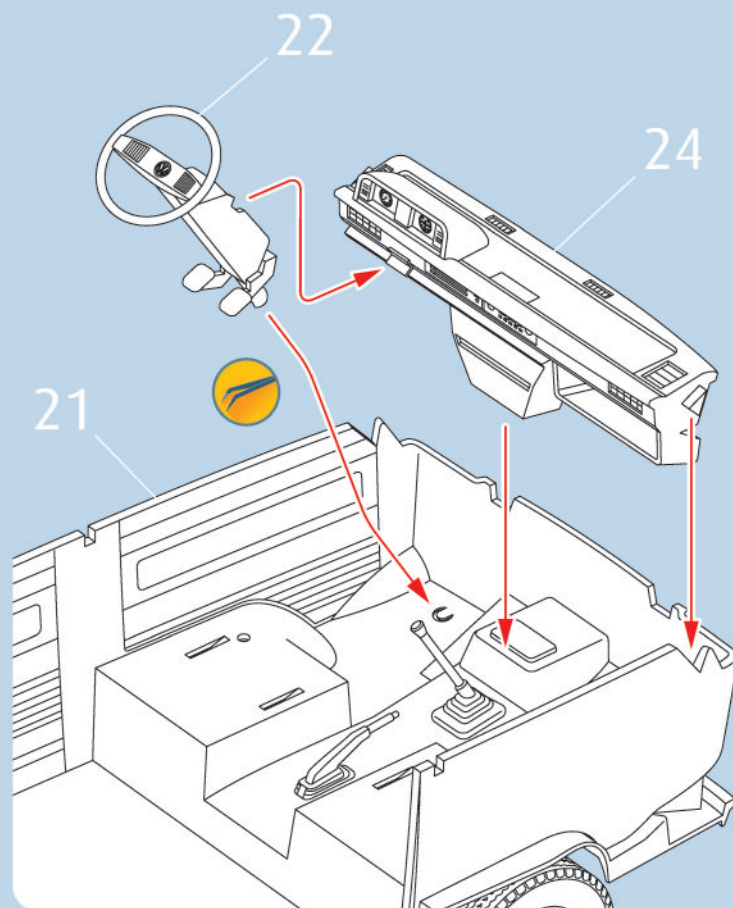

26

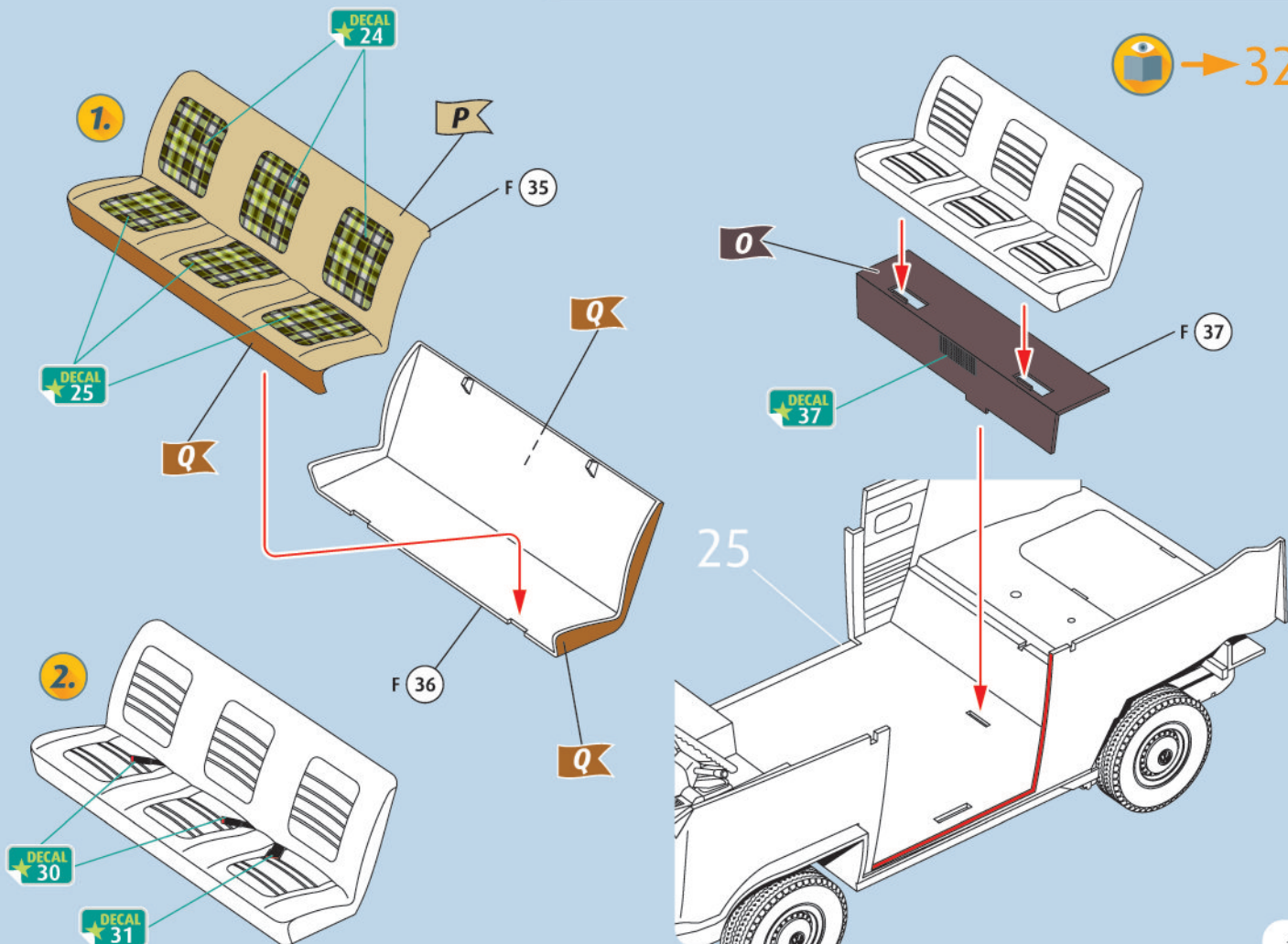

27

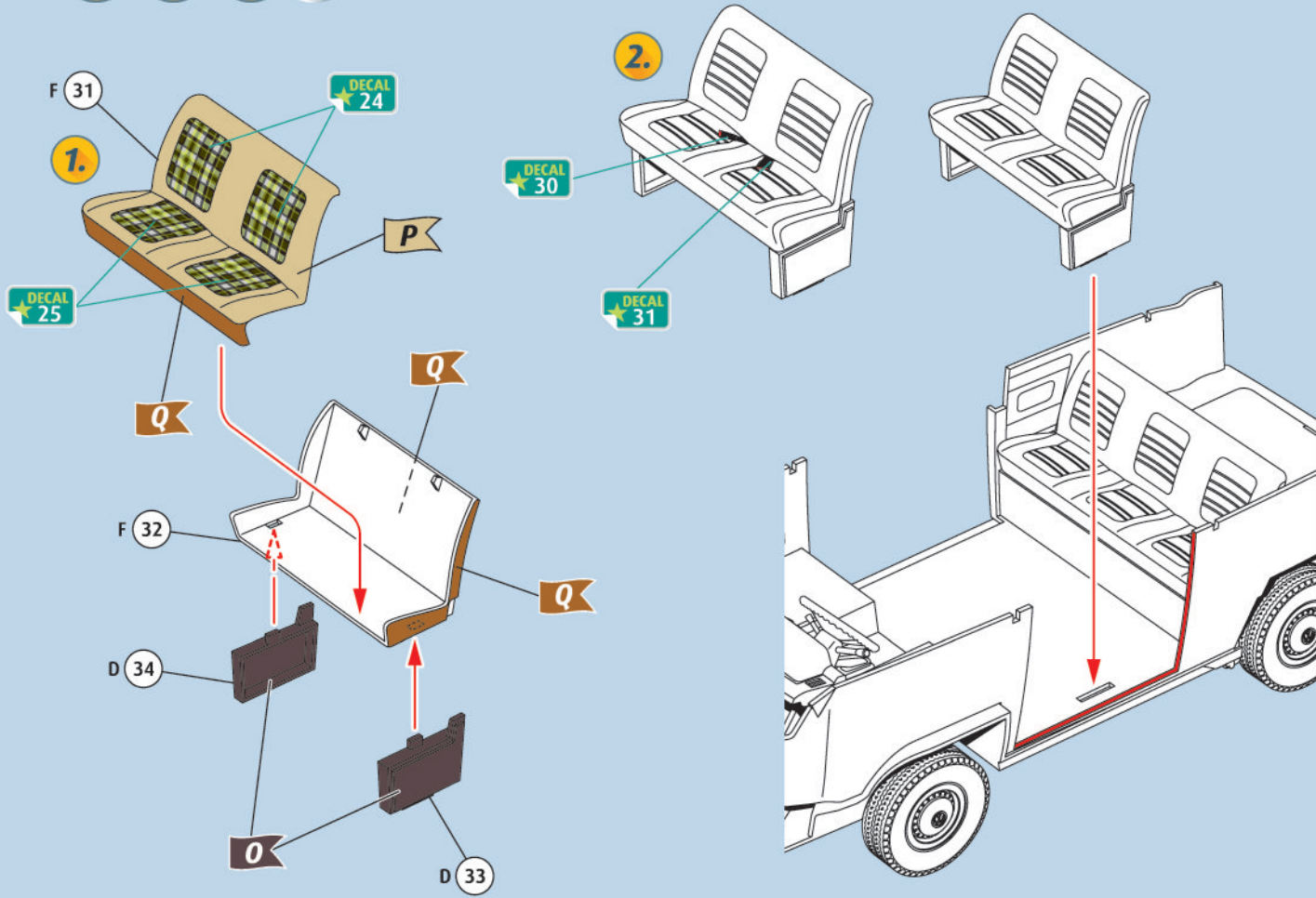

28

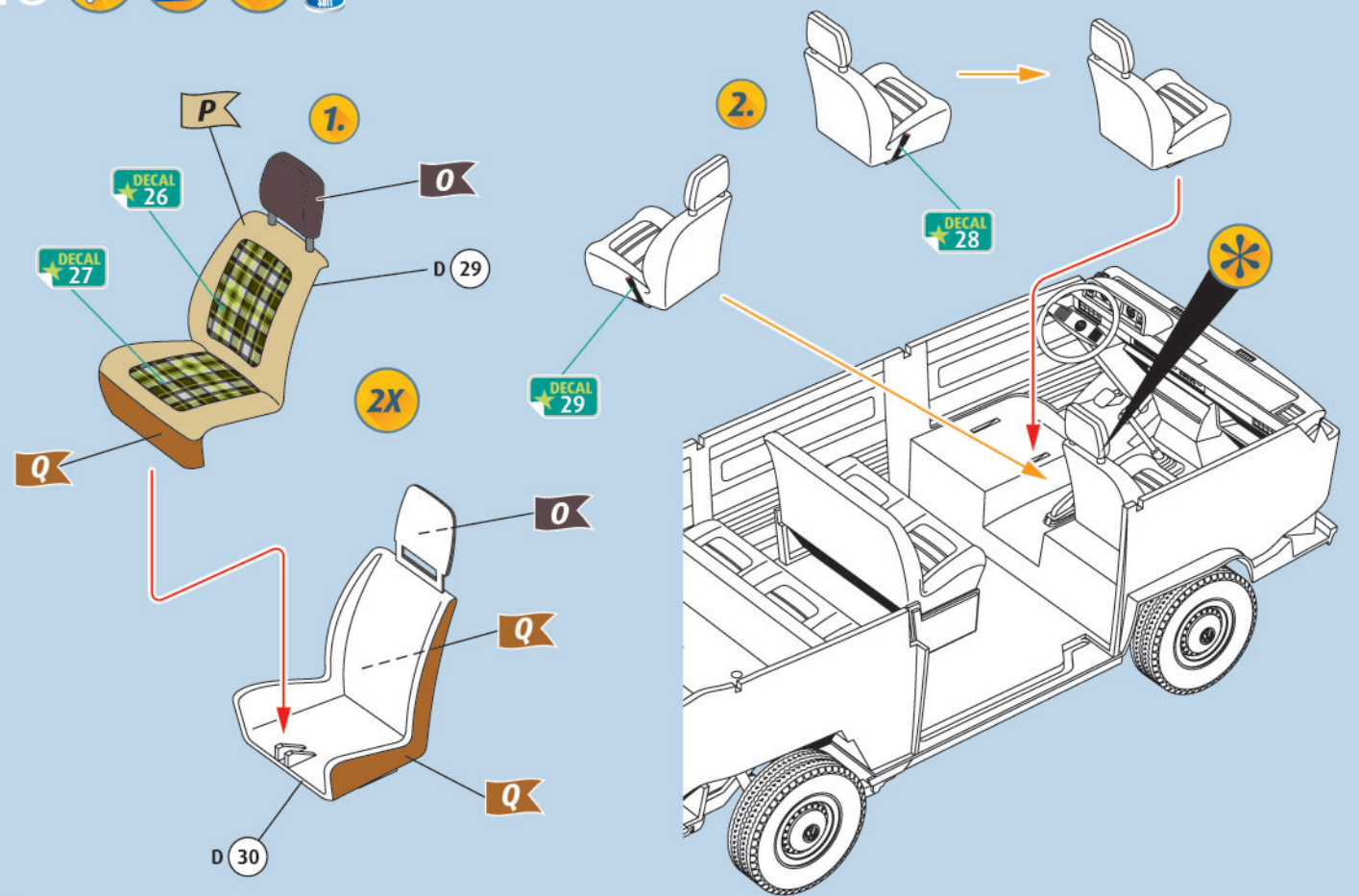

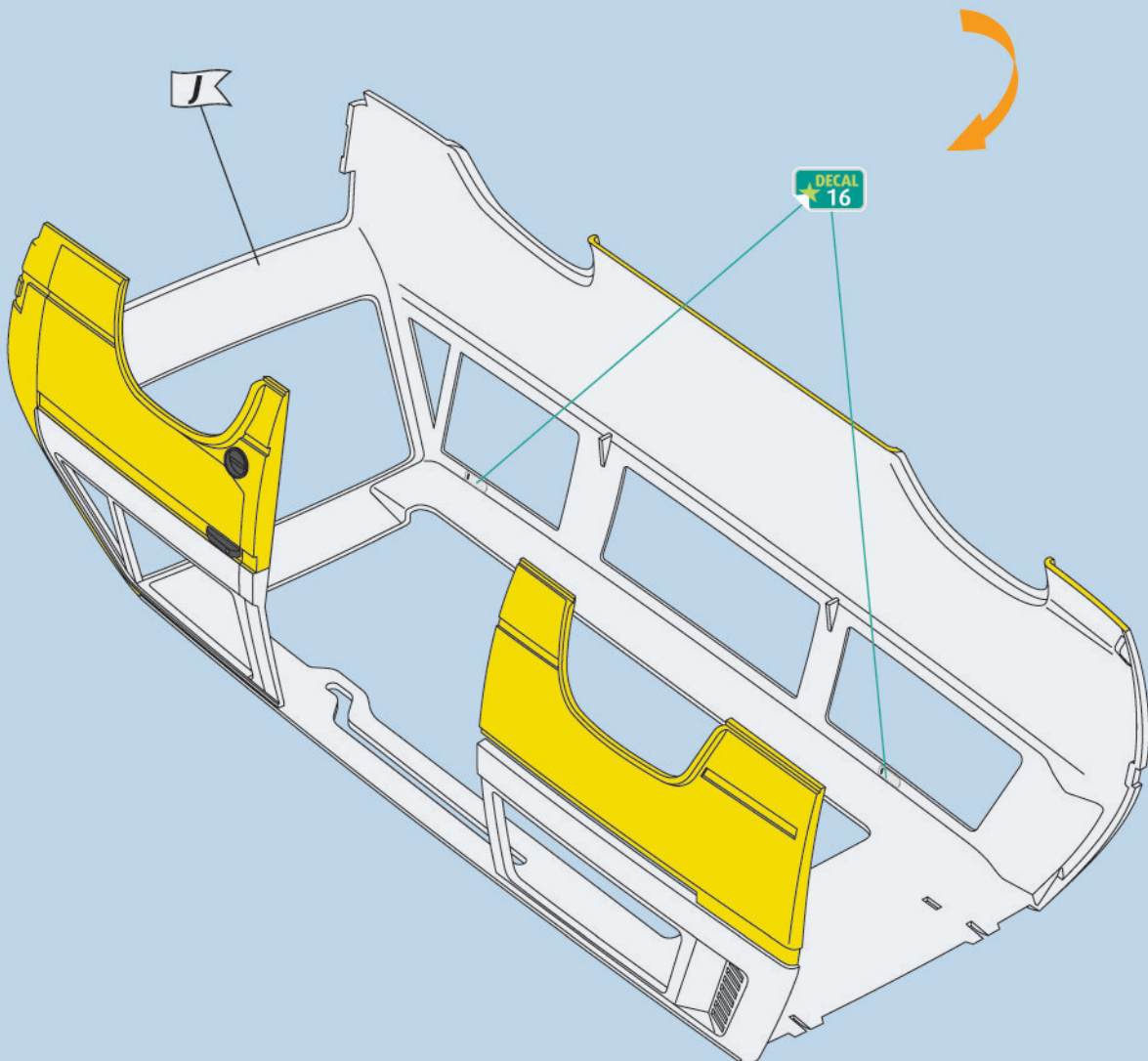
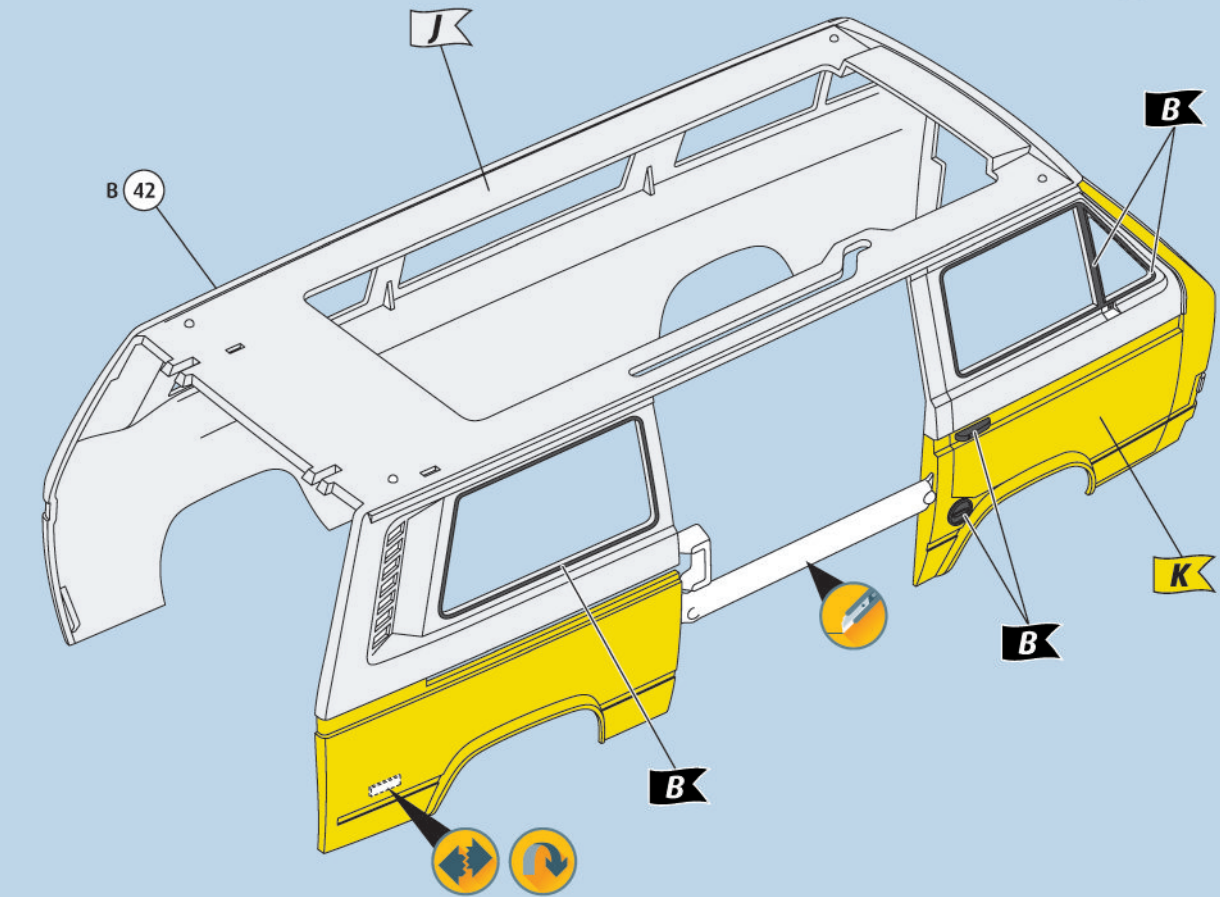

30

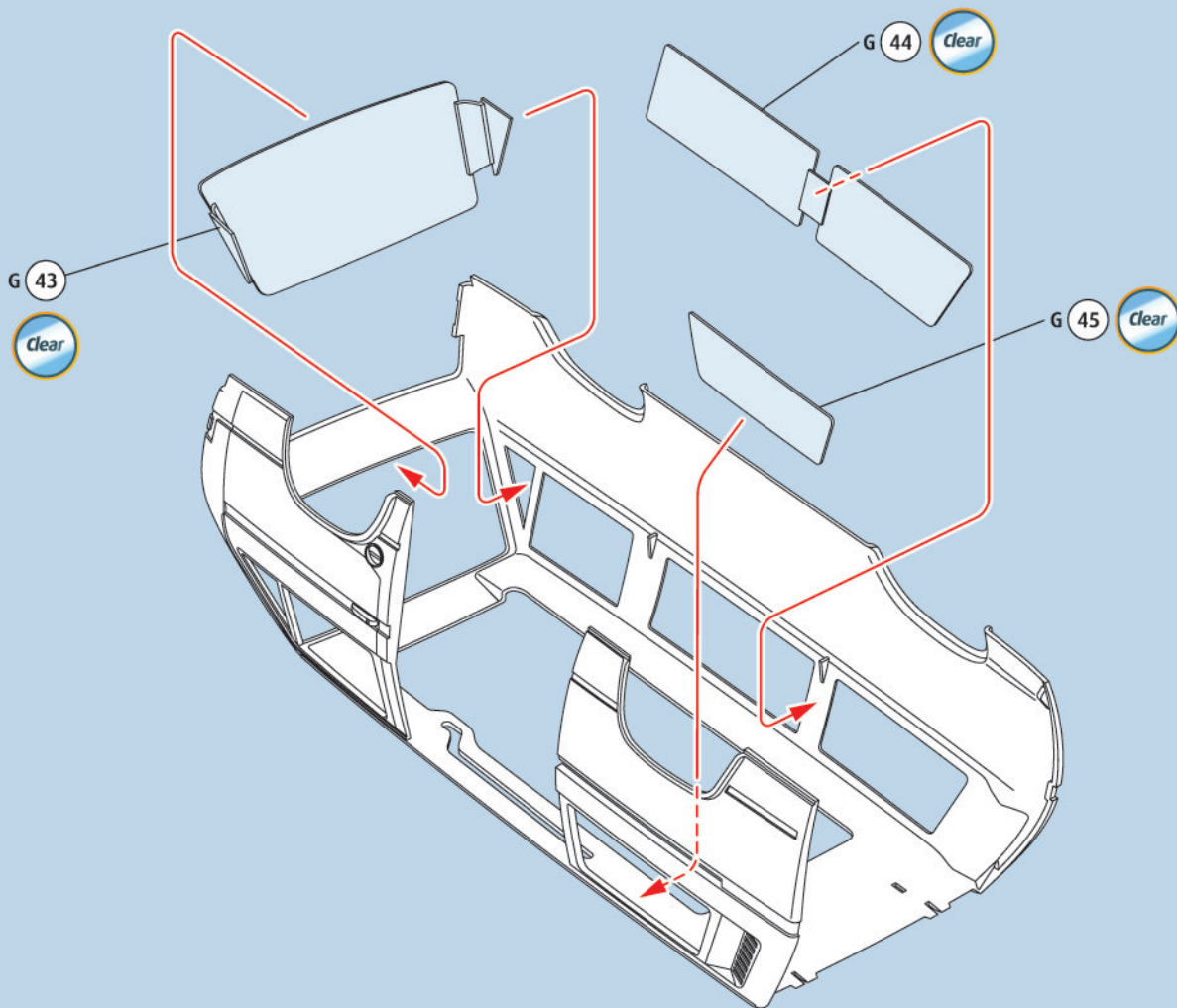

31

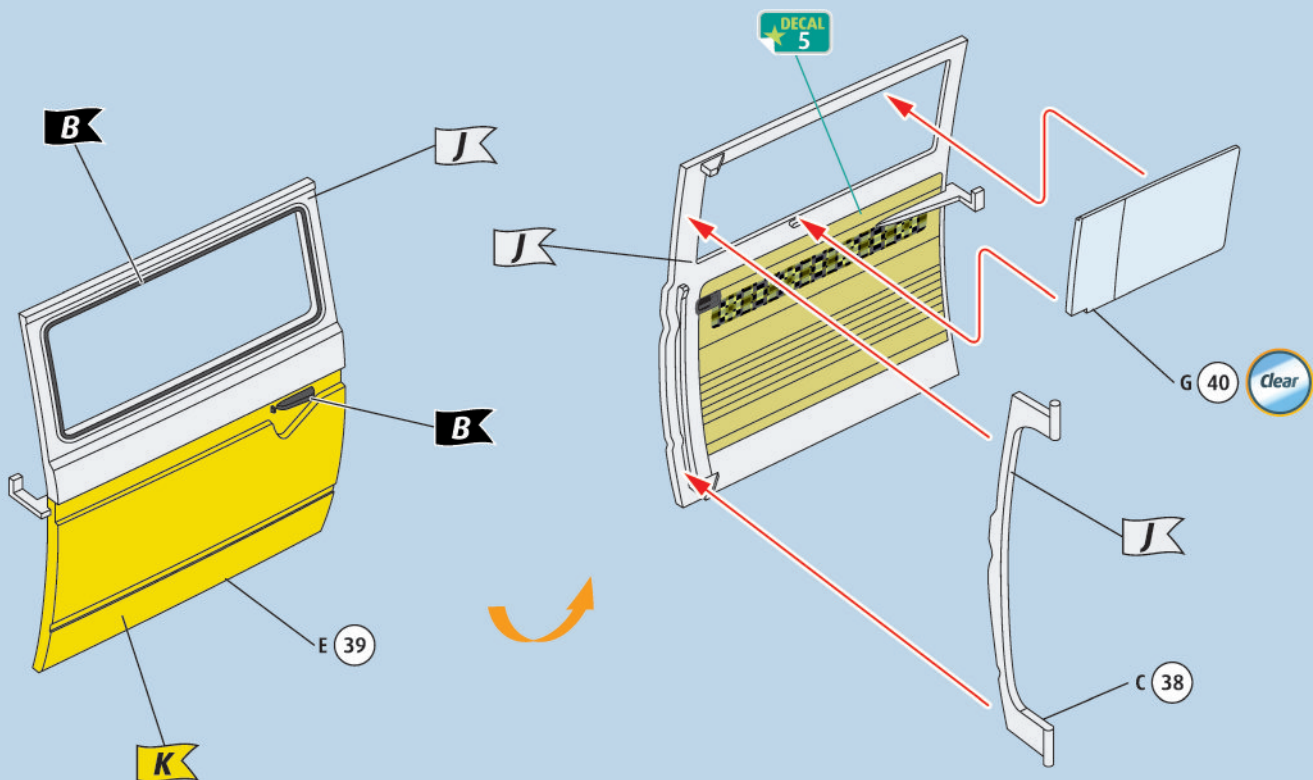

32

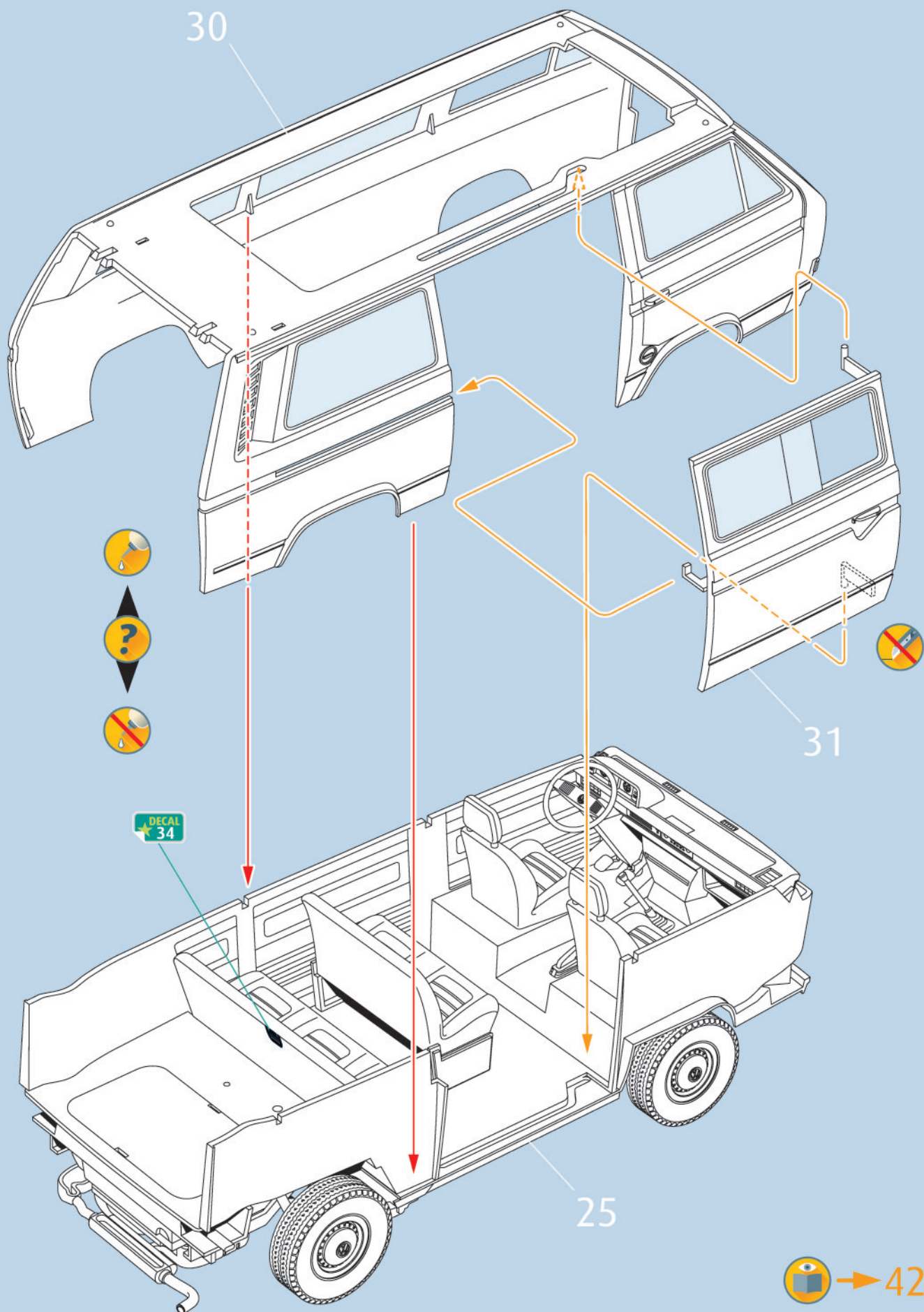

33

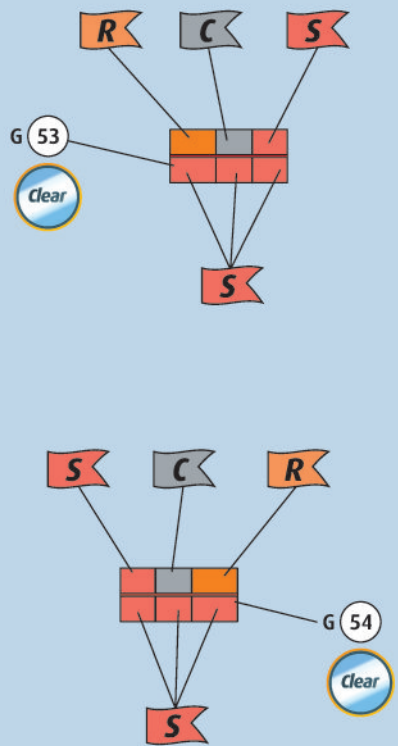
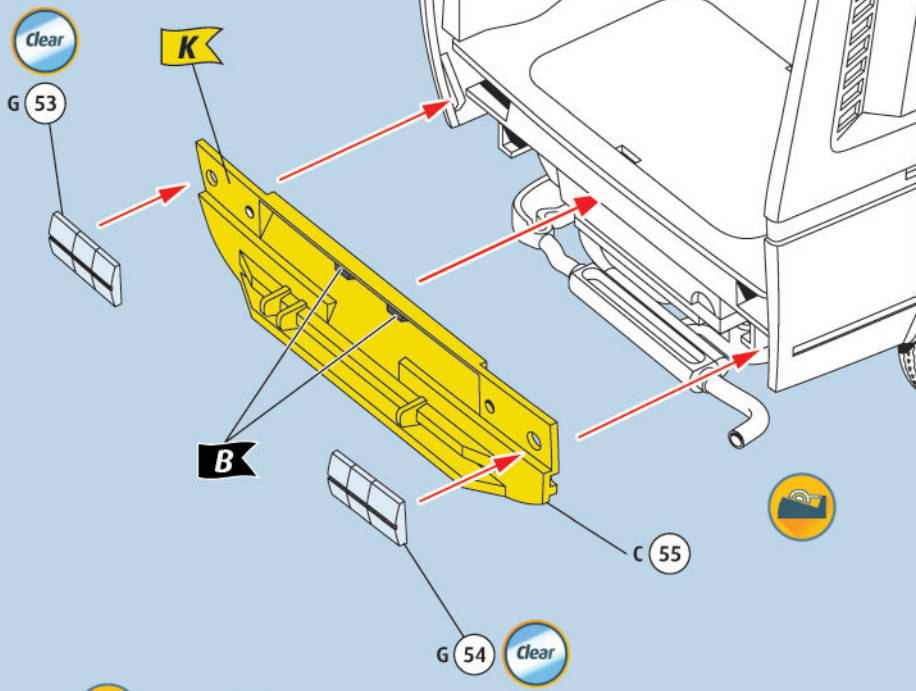

→ 42

**COLOURING
INNER SIDE**

34



- 1. **B**
- 2. **DECAL 43**

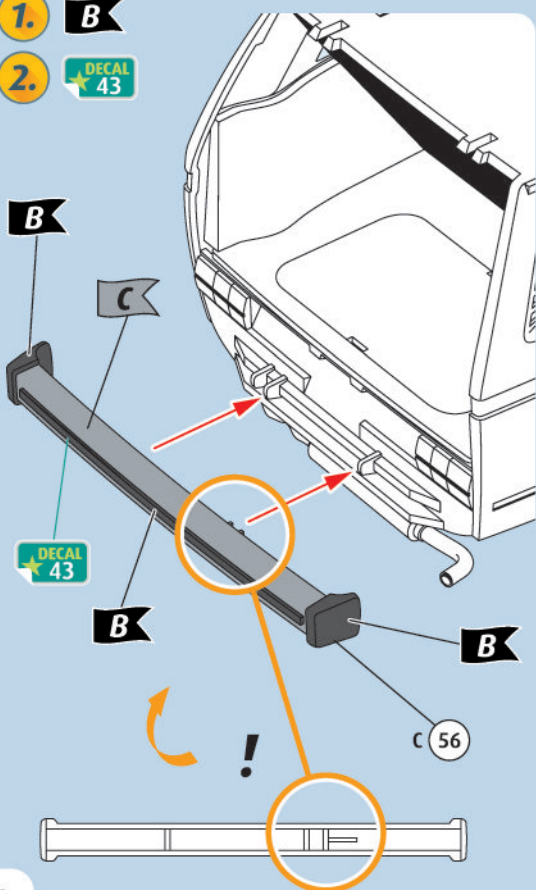

35

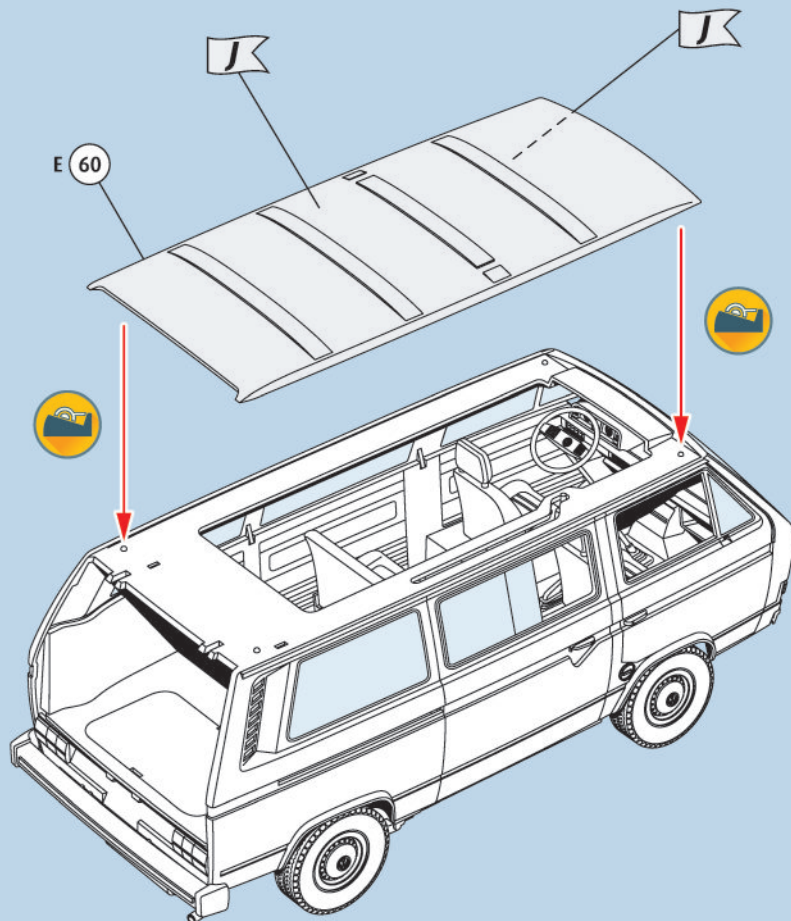

36

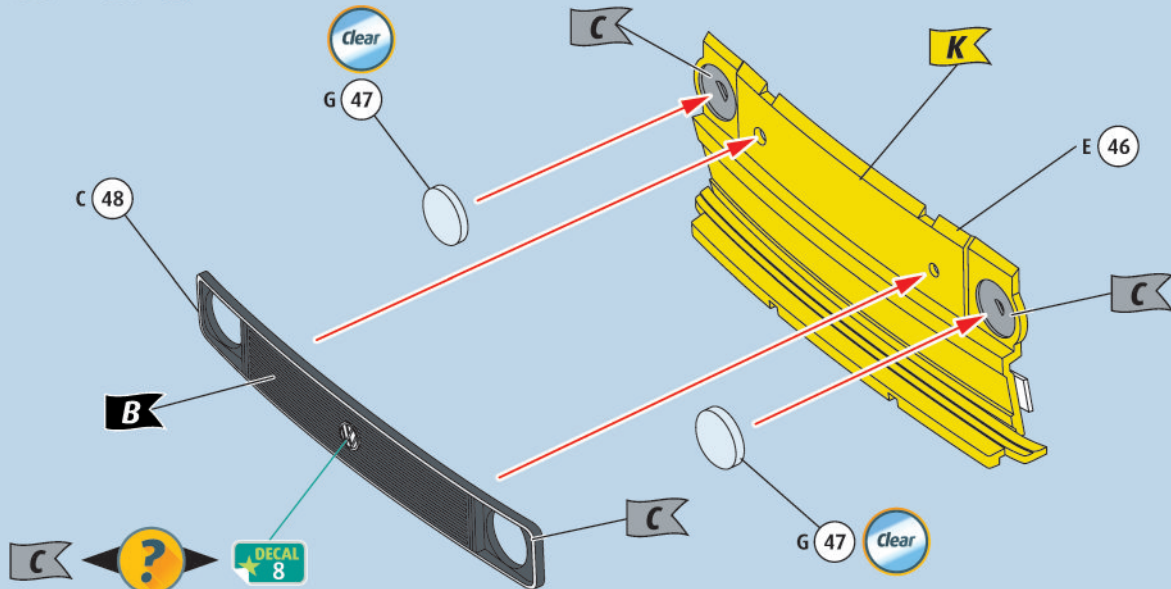

37

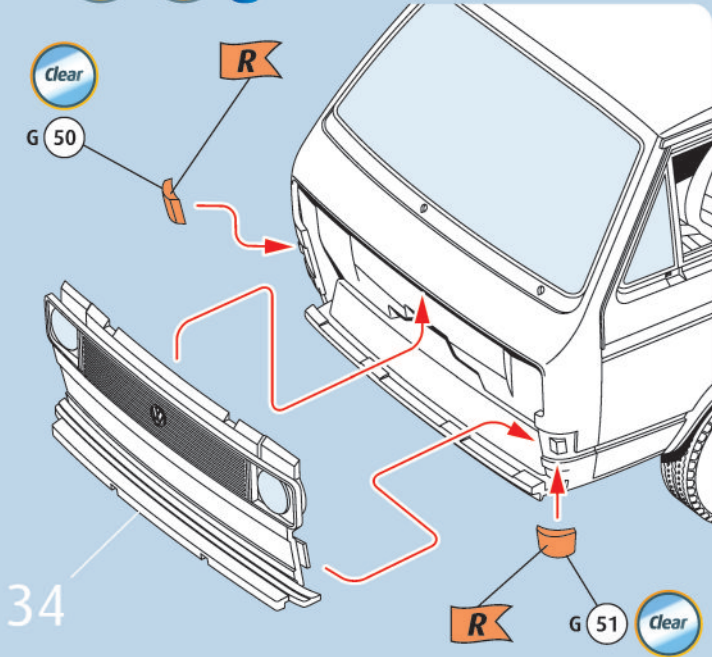

38

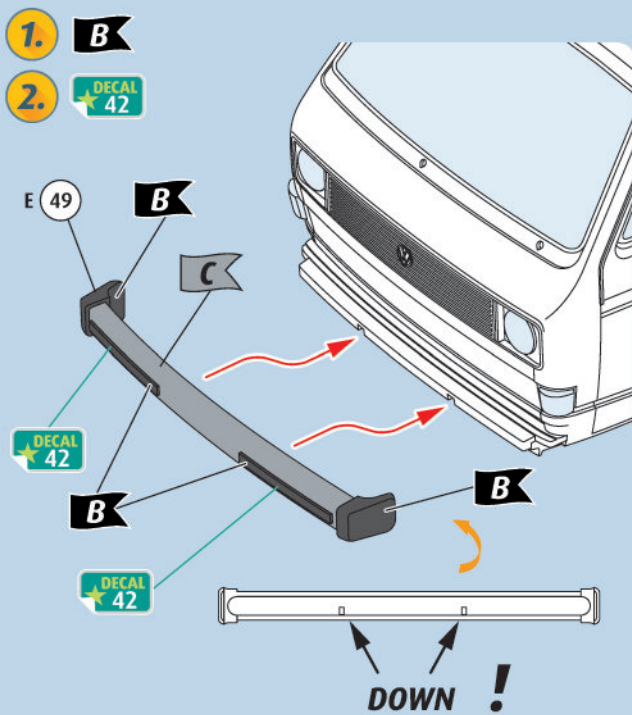

39

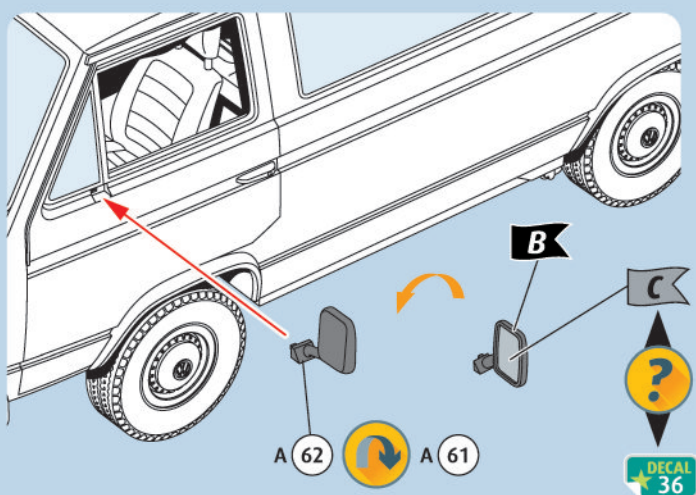

40

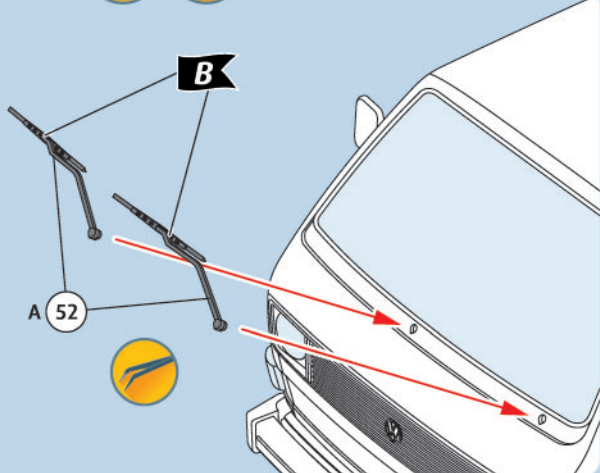

41

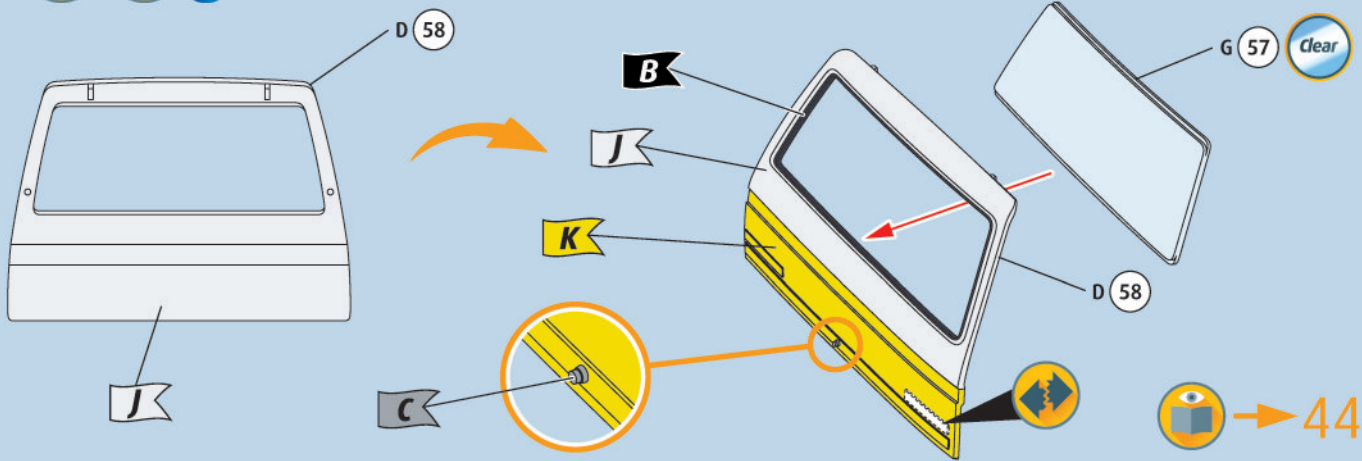

42

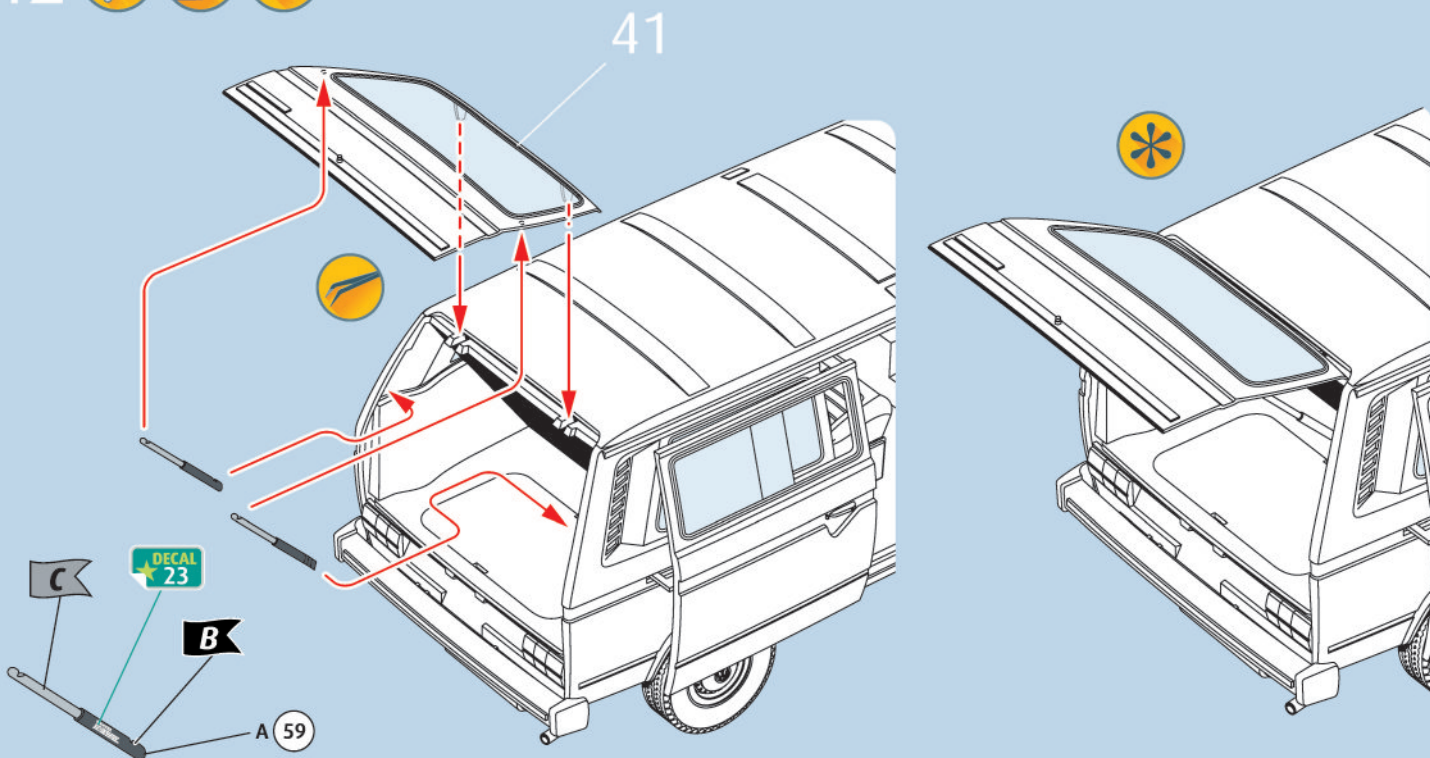

43

