



1:35 Ferret Scout Car Mk.2

A1379 SCALE MODEL CONSTRUCTION KIT | Length: 112mm Height: 55mm Width: 54.6mm | Three Decal Schemes Included

EN A successful series of light armoured reconnaissance and liaison vehicles, the Ferret Scout Car saw widespread British and Commonwealth military service from the 1950s onwards, with later variants of the Ferret taking part in the Gulf War of 1990. A vehicle type which can trace its lineage back to the successful Daimler Dingo scout car of the Second World War, the Ferret was designed with stealth in mind, a light and fast armoured vehicle which could probe enemy positions, reporting any discovered weak points back to commanders, with their own forces moving to exploit what they found.

FR Constituant une série réussie de véhicules blindés légers de reconnaissance et de liaison, les automitrailleuses Ferret, également appelées « scout cars » ont été largement utilisées par l'armée britannique et du Commonwealth à partir des années 1950. Des variantes ultérieures ont participé à la guerre du Golfe de 1990. Type de véhicule dont la lignée remonte aux blindés de reconnaissance réussis Daimler Dingo de la Seconde Guerre mondiale, la Ferret a été conçue dans une optique de discrétion, pour en faire un véhicule blindé léger et rapide capable de sonder les positions ennemies et de signaler aux commandants les points faibles détectés pour que leurs propres forces puissent les exploiter.

DE Die als leichte Radpanzer für den Aufklärungs- und Verbindungseinsatz entwickelte Reihe von Ferret Scout Cars wurde ab Anfang der 1950er Jahre von den Streitkräften Großbritanniens und des Commonwealth erfolgreich eingesetzt. Spätere Varianten des Ferret wurden sogar noch 1990 im Golfkrieg verwendet. Der eigentliche Fahrzeugtyp geht auf den im Zweiten Weltkrieg gebauten Spähpanzer Daimler Dingo zurück. Der Ferret (englisch „Frettchen“) war auf Tarnung ausgerichtet. Als leicht gepanzert, schneller Kraftwagen sollte er Feindpositionen flink ausspähen können, um eventuelle Schwachpunkte des Gegners rasch an Kommandanten zurückzumelden, damit sie solche Situationen prompt ausnutzen konnten.

ES El Ferret Scout, un vehículo blindado ligero de reconocimiento y enlace de gran éxito, fue utilizado por las fuerzas armadas del Reino Unido y la Commonwealth a partir de la década de 1950. Las versiones posteriores del Ferret participaron en la Guerra del Golfo de 1990. El Ferret, un tipo de vehículo basado en el exitoso Daimler Dingo de la Segunda Guerra Mundial, se desarrolló con el objetivo de ser un vehículo blindado sigiloso, ligero, rápido y capaz de sondear las posiciones enemigas e informar a los comandantes de los puntos débiles descubiertos y movilizar a sus fuerzas para aprovechar lo encontrado. Con un peso operativo de unas 4 toneladas, el Ferret estaba totalmente soldado y contaba

SV Ferret Scout Car var en framgångsrik serie med lätt bepansrade spanings- och sambandsfordon som användes i stor utsträckning av brittisk militär och samväldets militär från 1950-talet och framåt, och senare varianter av Ferret användes i Gulfkriget 1990. Ferret är en fordonstyp vars anor sträcker sig tillbaka till den framgångsrika spaningsbilen Daimler Dingo som användes under andra världskriget. Ferret utformades med smygmetoder i åtanke – ett lätt och snabbt bepansrat fordon som kunde sondera fiendens ställningar och rapportera eventuella svaga punkter till befälhavarna, så att de egna styrkorna i sin tur kunde förflytta sig framåt för att dra nytta av den inhämtade informationen. Ferret hade en tjänstevikt på runt 4 ton, var helt svetsad och hade ett pansarskydd som

Weighing in at around 4 tons operational weight, the Ferret was of all welded construction and featured armour protection capable of withstanding most small arms fire, but nothing much heavier, although it was not intended that the vehicle would be operating in direct opposition to heavy enemy armour. If it did find itself in a bit of trouble, the 4 wheel drive Ferret was powered by a reliable 6 cylinder Rolls Royce engine which gave it a top speed of 45 mph, a speed it could also achieve in reverse if required, something which could prove extremely useful if the crew found themselves in a tight spot.

D'un poids en ordre de combat d'environ 4 tonnes, la Ferret possédait une construction entièrement soudée et disposait d'un blindage de protection capable de résister à la plupart des tirs d'armes légères, mais pas beaucoup plus, car il n'était pas prévu qu'elle soit déployée en opposition directe aux blindés lourds ennemis. Si elle se trouvait en difficulté, la Ferret à quatre roues motrices pouvait compter sur son moteur Rolls Royce 6 cylindres qui lui donnait une vitesse maximale de 72 km/h en marche avant comme en marche arrière en cas de besoin, ce qui pouvait s'avérer extrêmement utile si l'équipage se trouvait dans une situation difficile.

Das Einsatzgewicht des Ferret betrug rund 4 Tonnen. Er war aus Panzerstahlplatten zusammengesetzt und bot Schutz vor Beschuss durch die meisten leichten Infanteriewaffen. Er war nämlich nicht für den Einsatz gegen schwerere Waffen konzipiert. Wenn der Ferret in schwierige Situationen geriet, erwies sich sein Vierradantrieb oft als nützlich. Mit seinem zuverlässigen Rolls-Royce-6-Zylindermotor konnte er eine Höchstgeschwindigkeit von über 70 km/h erreichen – sogar im Rückwärtsgang, wofür seine Besatzungen sicherlich oft dankbar waren.

con una protección de blindaje que podía resistir la mayoría de los disparos de armas ligeras, pero no mucho más pesadas, aunque no se pretendía utilizar el vehículo en oposición directa al blindaje pesado del enemigo. En caso de dificultades, el Ferret, con tracción en las cuatro ruedas, contaba con un fiable motor Rolls Royce de 6 cilindros que le proporcionaba una velocidad máxima de 72 km/h, también posible marcha atrás llegado el caso, algo que podía resultar muy útil si la tripulación se encontraba en un aprieto.

kunde stå emot de flesta handeldvapen, men ingenting mycket tyngre än så. Det var dock inte meningen att fordonet skulle användas i direkta strider mot tungt bepansrade fiendetrupper. Om den hamnade i knipa kunde den fyrhjulsdrivna Ferret ta sig iväg med hjälp av sin tillförlitliga sexcylindriga Rolls Royce-motor som gav den en högsta hastighet på runt 72 km/h. Vid behov kunde fordonet även backa i samma hastighet, något som i kniviga lägen kunde komma väl till pass.

Airfix would like to thank Simon Mallett, Brian Laker, The Isle of Wight Military & Heritage Museum & Paul Thompson for their help researching the model.

FOR BEST RESULTS:

Surfaces to be painted should be clean – before parts are removed from the sprue, wash in warm, soapy water, rinse and dry thoroughly. Stir paints thoroughly before use.

PLEASE NOTE:

Some parts in the kit may not be required to build the model specified.

**HORNBY
HOBBIES**



Manufactured by: Hornby Hobbies Ltd Westwood, Margate, Kent, CT9 4JX, UK +44(0)1843 233525 customerservices.uk@hornby.com

EU Authorised Representative: Hornby Italia SRL Viale dei Caduti, 52/A6, Castel Mella (BS), Italy, 25030 +39 0687501292 customerservices.it@hornby.com

ASSEMBLY INSTRUCTIONS

EN Study drawings and practise assembly before cementing parts together. Carefully scrape paint from cementing surfaces. All parts are numbered. Paint small parts before assembly. To apply decals cut sheet as required, dip in warm water for a few seconds, slide off backing into position shown. Use in conjunction with box artwork. Not appropriate for children under 36 months of age, due to the presence of small detachable parts.

FR Étudier attentivement les dessins et simuler l'assemblage avant de coller les pièces. Gratter soigneusement toute peinture sur les surfaces à coller. Toutes les pièces sont numérotées. Peindre les petites pièces avant l'assemblage. Pour coller les décalcomanies, découper le motif, le plonger quelques secondes dans de l'eau chaude puis le poser à l'endroit indiqué en décollant le support papier. Utiliser conjointement avec les illustrations sur la boîte. Ne convient pas aux enfants de moins de 36 mois – présence de petits éléments détachables.

DE Vor dem Zusammenkleben der Teile die Zeichnungen sorgfältig ansehen und die zu verklebenden Teile zur Vermeidung möglicher Fehler versuchsweise zusammenfügen. Dann an den Klebeflächen vorhandene Farbbeschichtung vor dem Zusammenkleben vorsichtig abkratzen. Alle Bestandteile sind mit Nummern versehen. Kleine Teile vor dem Zusammenbau bemalen. Abziehbilder wie gewünscht ausschneiden. Vor dem Anbringen einige Sekunden in warmes Wasser tauchen und dann vom Trägerpapier in ihre vorgesehene Position schieben. Dabei die Abbildungen auf der Schachtel beachten. Nicht für Kinder unter 36 Monaten geeignet, da abnehmbare bzw. lose angebrachte Kleinteile enthalten sind.

ES Estudiar los dibujos y practicar el montaje antes de pegar las piezas. Raspar cuidadosamente la pintura en las superficies de contacto antes de pegar las piezas. Todas las piezas están numeradas. Es conveniente pintar las piezas pequeñas antes de su montaje. Para aplicar las calcomanías, cortarlas de la hoja, sumergirlas en agua tibia durante unos segundos y deslizarlas a la posición indicada. Utilizar en conjunción con la ilustración de la caja. No es adecuado para niños menores de 36 meses, ya que contiene piezas pequeñas que podrían soltarse.

SV Studera bilderna noggrant och sätt ihop delarna innan du limmar ihop dem. Skrapa försiktigt bort färg från limmade delar. Alla delarna är nummerade. Måla smådelarna före ihopsättning. Sätt fast dekalerna genom att klippa arket, doppa i varmt vatten några sekunder in låta baksidan glida på plats som bilden visar. Använd enligt bildanvisningarna på kartongen. Rekommenderas ej för barn under 3 år. Innehåller löstagbara smådelar.

NL Tekeningen bestuderen en delen in elkaar zetten alvorens deze te lijmen. Lak voorzichtig van lijmvlakken afschrapen. Alle delen zijn genummerd. Kleine delen vóór montage verven. Voor aanbrengen van stickers, gewenste stickers uit het vel knippen, een paar seconden in warm water dompelen en dan van het schutblad af op afgebeelde plaats schuiven. Hierbij afbeelding op doos raadplegen. Niet geschikt voor kinderen onder 3 jaar, omdat kleine dr altes gemakkelijk kunnen losraken.

PO Przed przystąpieniem do sklejania przestuduj uważnie rysunki i przećwicz składanie części. Ostrożnie zeskrób ze sklejanych powierzchni farbę. Wszystkie części są ponumerowane. Drobne części pomaluj przed ich złożeniem. Celem przeniesienia kalkomanii wytnij ją z arkusza, zanurz na kilka sekund w letniej wodzie i zsuń z podłoża na wymagane miejsce. Używaj w połączeniu ze wzorami na pudełku. W związku z obecnością wielu drobnych, rozbielalnych części, nieodpowiednie dla dzieci poniżej 3 lat.

IT Studiare i disegni ed esercitarsi a montare i vari pezzi prima di fissarli con la colla. Raschiare con cura le tracce di vernice dalle superfici da incollare. Tutti i pezzi sono numerati. Verniciare i pezzi di piccole dimensioni prima di montarli. Per applicare le decalcomanie, ritagliare il foglio nel modo richiesto, immergere in acqua calda per alcuni secondi, quindi staccare la decalcomania dalla carta di supporto e posizionarla nel punto desiderato. Usare le decalcomanie come indicato nell'illustrazione riportata sulla confezione. Non adatto a bambini di età inferiore a 36 mesi per la presenza di componenti di piccole dimensioni che potrebbero staccarsi.

PT Estudar atentamente os desenhos e experimentar a montagem. Raspar cuidadosamente as superfícies de modo a eliminar pintura antes de colar. Todas as peças estão numeradas. Pintar as pequenas peças antes de colar. Para aplicar as decalcomanias, cortar as folhas e mergulhar em água morna por alguns segundos, depois deslizar e aplicar no respectivo lugar, como indicado nas ilustrações na caixa. Não convém a uma criança de menos de 36 meses devido à presença de pequenos elementos destacáveis.

EL Μελετήστε προσεκτικά τα σχέδια και συναρμολογήστε για πρώτη φορά τα κομμάτια χωρίς να τα συγκολλήσετε. Αφαιρέστε επιμελώς την πλαστική βαφή από τις επιφάνειες τις οποίες θα συγκολλήσετε. Όλα τα κομμάτια είναι αριθμημένα. Χρωματίστε τα μικρά κομμάτια πριν από τη συναρμολόγηση. Για να κολλήσετε τις χαλκομανίες, κόψτε γύρω από το σχέδιο όπως απαιτείται, βυθίστε το μερικά δευτερόλεπτα σε χλιαρό νερό και μετά τοποθετήστε το στη θέση που υποδεικνύεται, αφαιρώντας τη μεμβράνη που το καλύπτει. Λάβετε υπόψη σας ταυτόχρονα την εικονογράφηση του κουτιού. Ακατάλληλο για παιδιά ηλικίας κάτω των 36 μηνών λόγω ύπαρξης μικρών κομματιών που αποσπώνται.

FI Tutustu piirroksiin ja harjoittele kokoamista, ennen kuin liimaat osat yhteen. Raaputa maali varovasti pois liimattavilta pinoilta. Kaikki osat on numeroitu. Maalaa pienet osat ennen kokoamista. Siirtokuvien kiinnittämiseksi leikkaa ne arkista tarpeen mukaan. Kasta kuva lämpimään veteen muutaman sekunnin ajaksi, anna takapuolen liukua kivalle osoitettuun kohtaan. Käytetään yhdessä laatikon kuvituksen kanssa. Ei suositella alle kolmivuotiaille lapsille. Paljon irotettavia pikkuosia.

DA Studér tegningerne nøje og forsøg at sætte delene sammen, inden de klæbes sammen. Skrab forsigtigt malingen af de overflader, der skal klæbes sammen. Alle dele er nummererede. Små dele skal males, før de monteres. Overføringsbillederne påføres ved at klippe dem ud af arket, som påkrævet, dypp dem i varmt vand i nogle få sekunder, hvorefter underlaget glides af i de viste positioner. Påføres ifølge illustrationerne på æsken. Ikke egnet til børn under 3 år på grund af tilstedeværelse af små aftagelige dele.

ASSEMBLY ICON INSTRUCTIONS

<p>1</p> <p>Assembly phase Phase de montage Montagephase Fase de montaje Monteringfasen Fase di montaggio Montagefase Fase de montagem Monteringsfase Kokoamisvaihe Faza składowania Φάση συναρμολόγησης</p>	<p>A1</p> <p>Cement Coller Kleben Nicht kleben Pegar Limma Incollare Lijmen Colar Klebes Kokoamisvaihe Liimaa Kleić Κολλήστε</p>	<p>Do not cement together No pas coller Nicht kleben Niet pegan Limma inte Non incollare Niet lijmen Não colar Skal ikke klæbes Älä liimaa Nie klei ć Μη συγκολλήσετε</p>	<p>Indicates final location Indique l'emplacement final Zeigt Endposition Indica la ubicación definitiva Anger slutmonteringsplats Sede di montaggio finale Geeft uiteindelijke locatie aan 'Indica localização final Viser endelig placering Osoittaa lopullisen sijainnin Oznacza miejsce docelowe Υποδεικνύει τελική τοποθεσία</p>	<p>Alternative part(s) provided Autre(s) pièce(s) fournie(s) Ersatzteil(e) mitgeliefert Se incluye(n) pieza(s) alternativa(s) Alternativ(a) del(ar) ingår Uno o più componenti alternativi forniti Alternatieve onderdelen meegeleverd Peças(s) alternativa(s) fornecida(s) Alternativ(e) del(e) medfølger Vaihtoehtoiset osat pakkausksessa Dostęne części zamienne Παρέχονται εναλλακτικά κομμάτια</p>	<p>x2</p> <p>Repeat this operation Répéter l'opération Vorgang wiederholen Repètir la operación Upprepa åtgärden Ripetere l'operazione De verrichting herhalen Repètir a operação Manövrer gentages Toista toimintapide Powtórzć operacj e Επανάλαβετε τη διαδικασία</p>	
<p>1</p> <p>Decals Décalcomanies Abziehbild Calcomanias Dekaler Decalcomanie Stickers Decalcomania Siirtokuvat Kalkomanie Χαλκομανίες</p>	<p>A1</p> <p>Crystal part Pièce cristal Kristallteil Pieza de cristal Kristalldel Pezzo cristallo Kristallen onderdeel Peça de cristal Krystalstykke Kristalliossa Część kryształowa Κομμάτι κρυστάλλου</p>	<p>1</p> <p>Weight Lester Beschweren Lastrar Belasta Appliquer un peso Verzwaren Lastrar Påfør vægt Aseta vastapaino Obciążyć balastem Επιθέστε βάρος</p>	<p>1</p> <p>Remove by filing Enlever avec une lime Abfeilen Eliminar con lima Ta bort genom att fila Rimuovere con la lima Verwijderen door afvijlen Remove limando Fjern ved at file væk Poista viilaamalla Usun aç przy użyciu pilnika Αφαιρέστε λιμόντας με λιμά</p>	<p>1</p> <p>Drill or pierce Perçer Durchbohren Perforar Borra Trapanare o forare Boren of doorboren Furar Gennembor Poraa tai puhkaise Wywierci ć lub przedziurawi ć Τρυπήστε</p>	<p>00</p> <p>Cut Découper Schneiden Cortar Skär Tagliare Snijden Cortar Skær Leikkaa Przeci ać Κόψτε</p>	<p>00</p> <p>Humbrol paint number No peinture Humbrol Humbrol-Farbennummer No de pintura Humbrol Humbrol färg nummer No vernice Humbrol Humbrol verfnummer No de pintura Humbrol Humbrol mallingsnummer Humbrol-maalin numero Nr farby Humbrol Νόμepο χρώματος Humbrol</p>

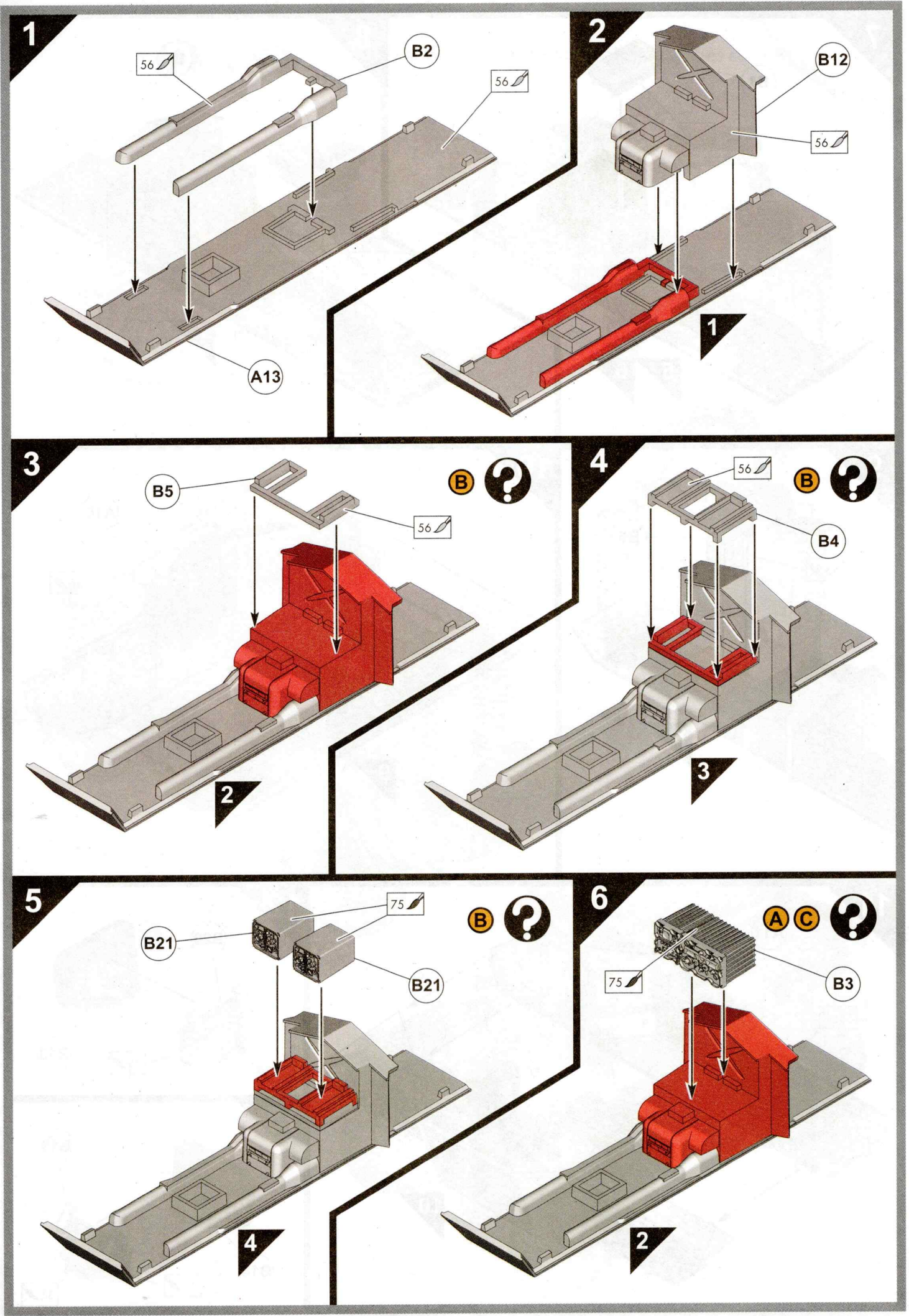

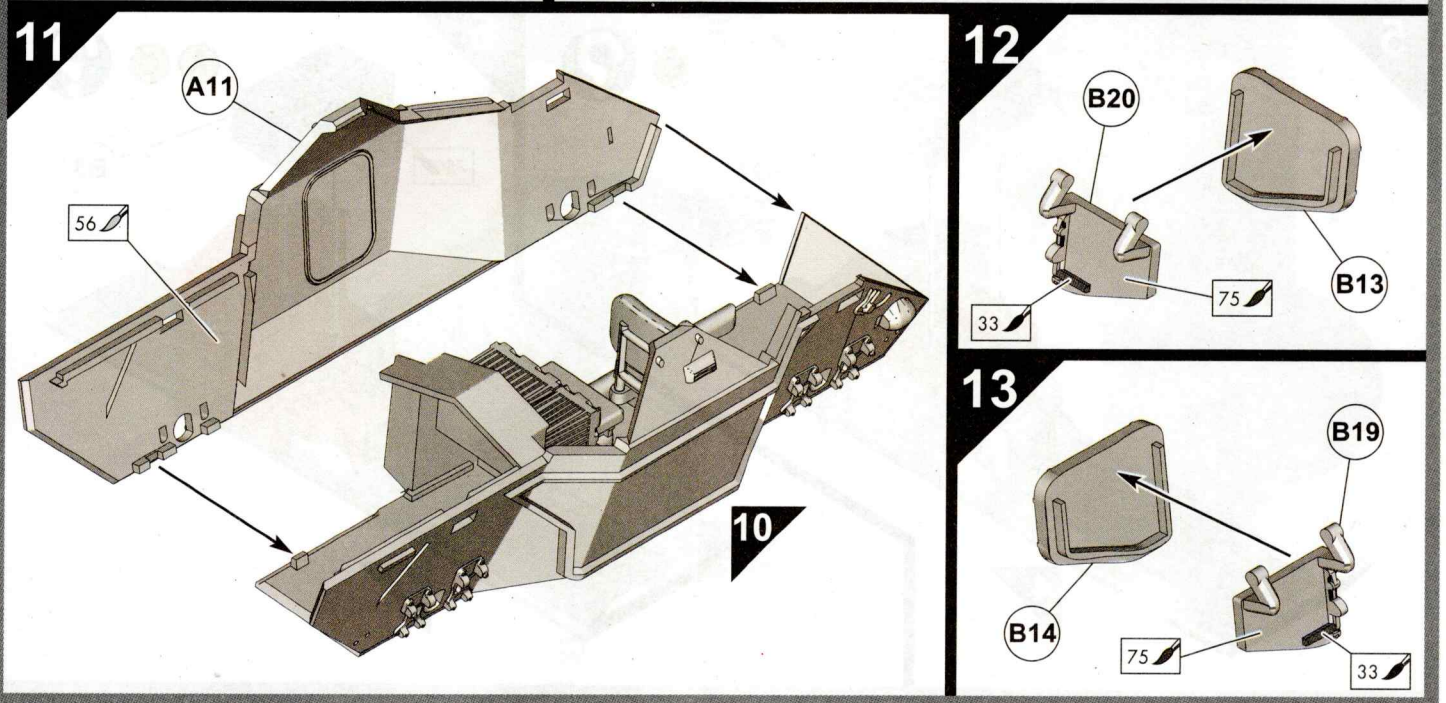
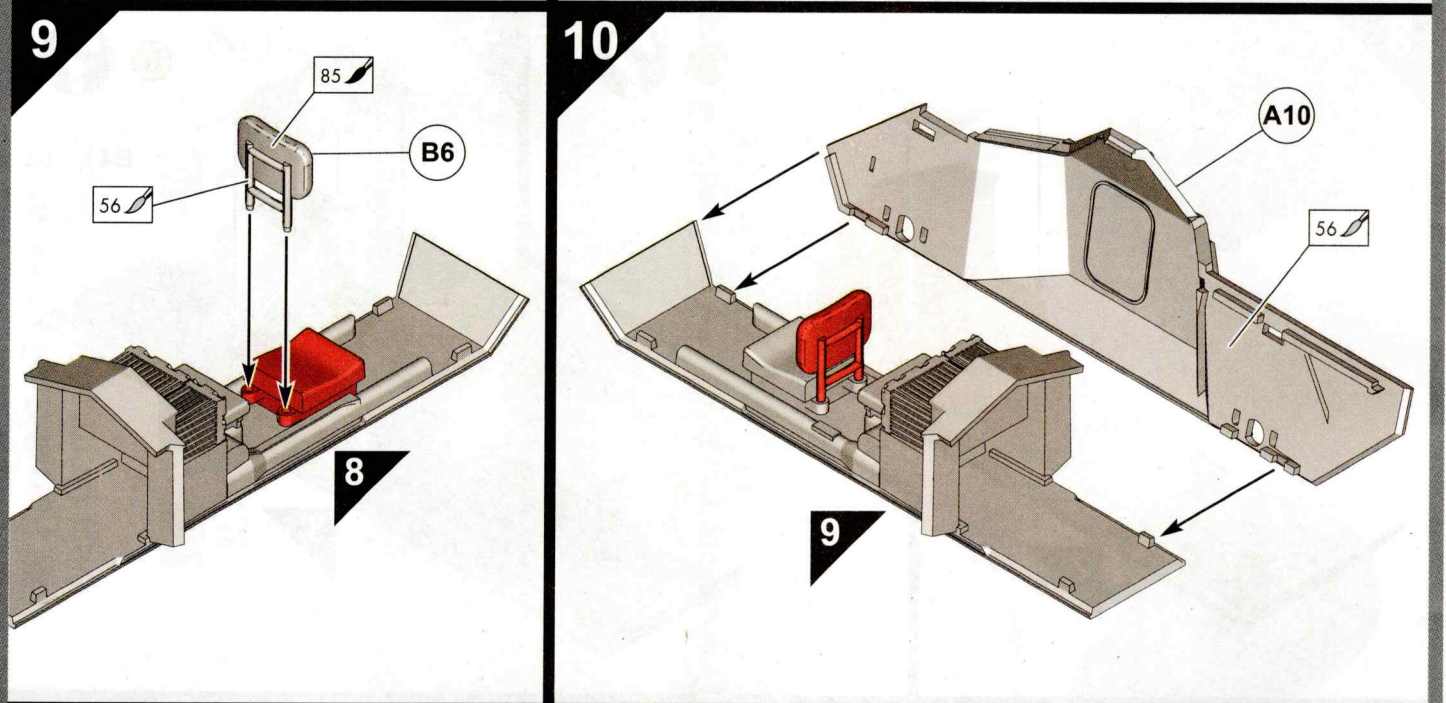
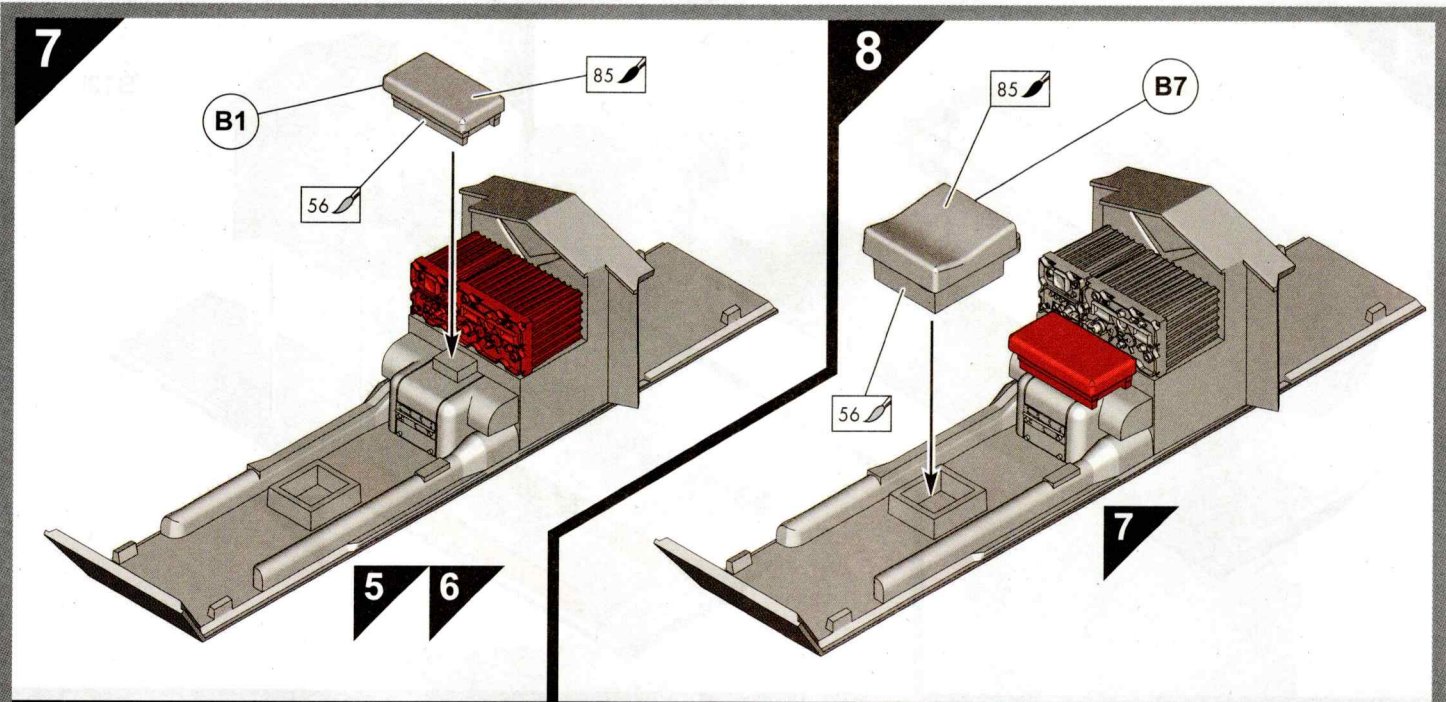

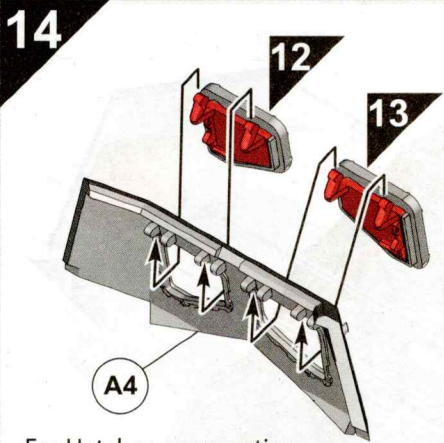

For Hatches open option, refer to step 98 on page 17.

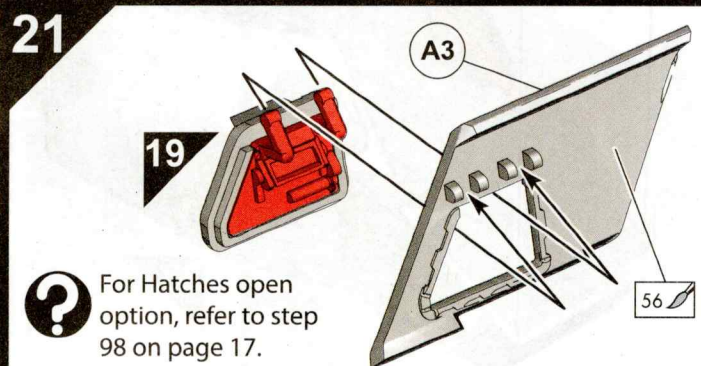
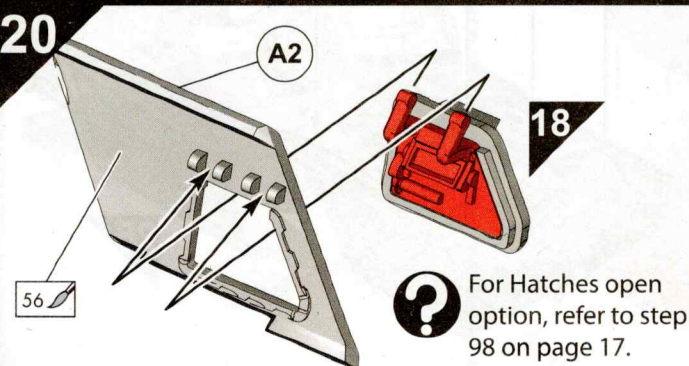
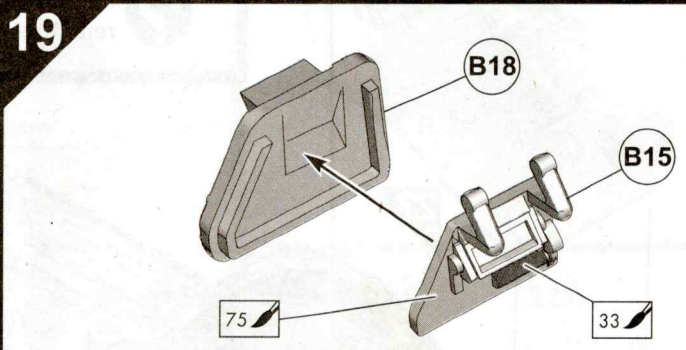
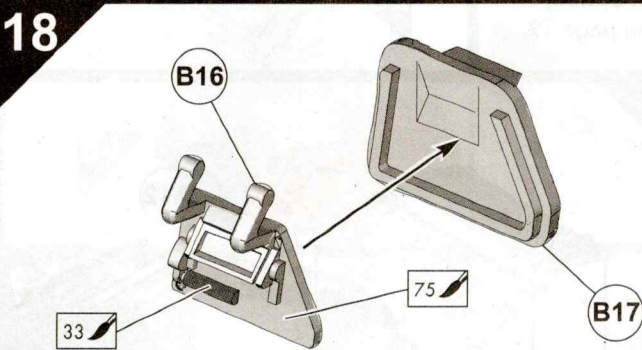
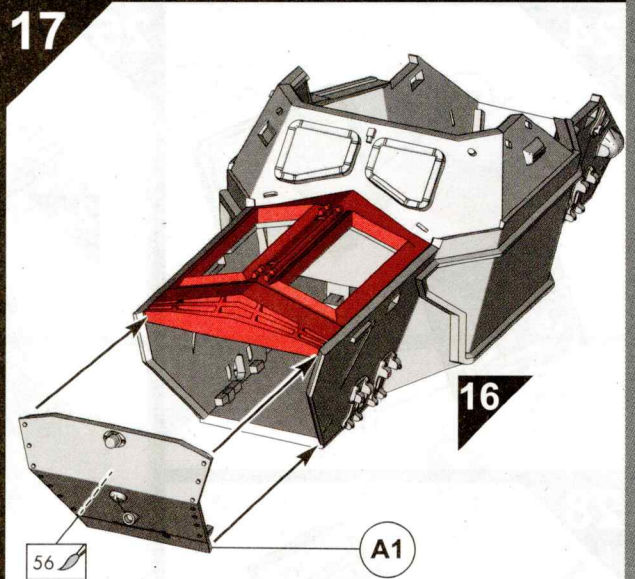
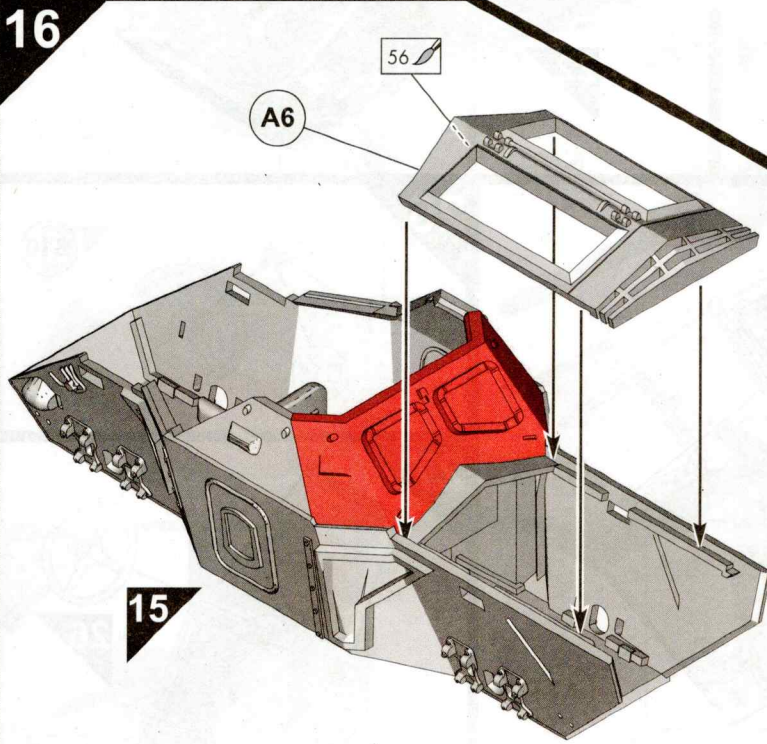
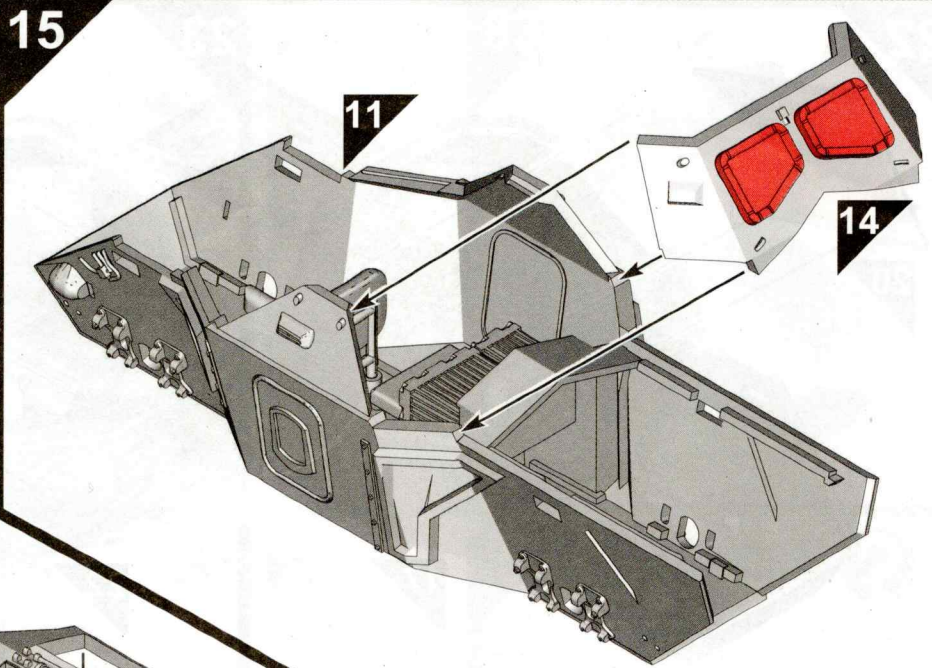

22

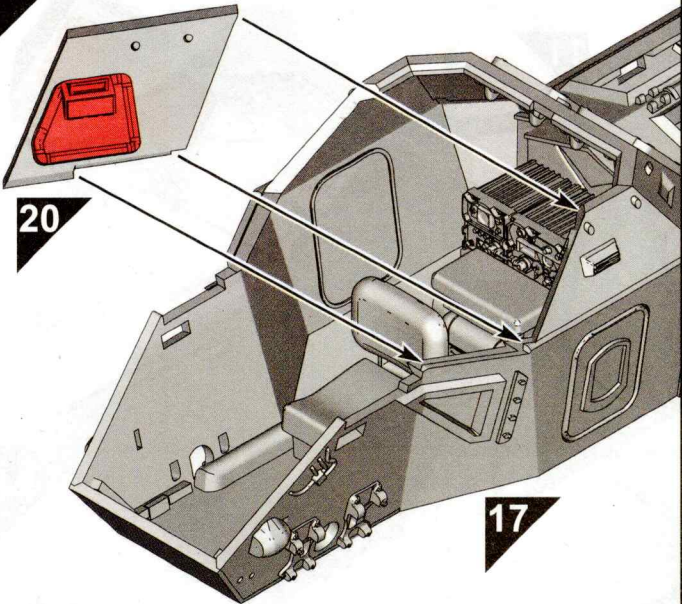

23

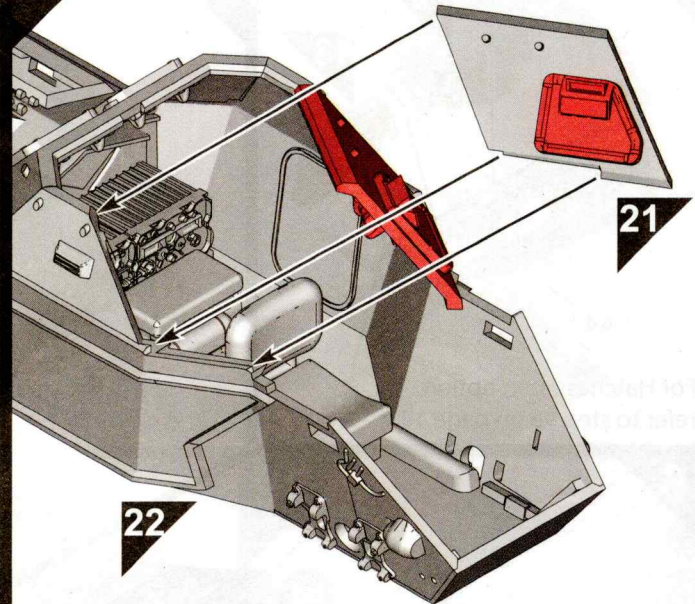

24

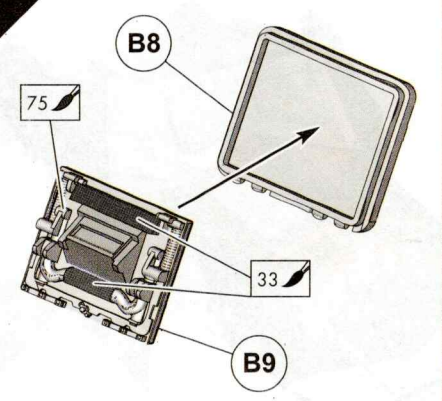

25

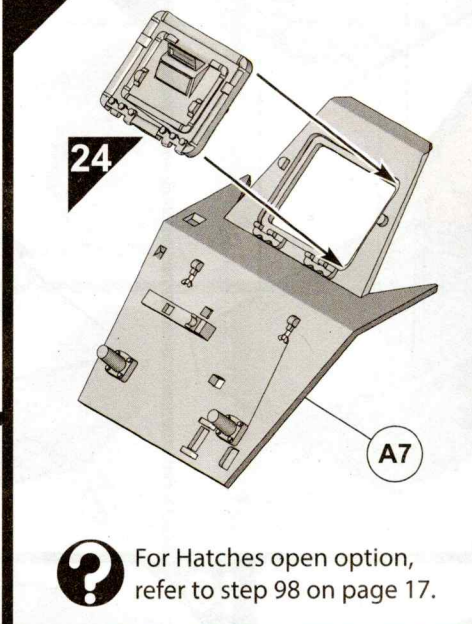

26

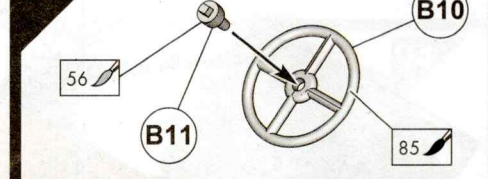

27

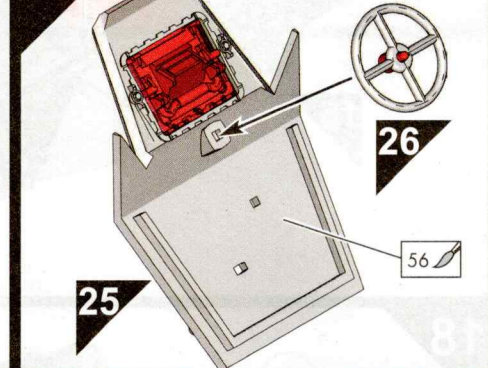

28

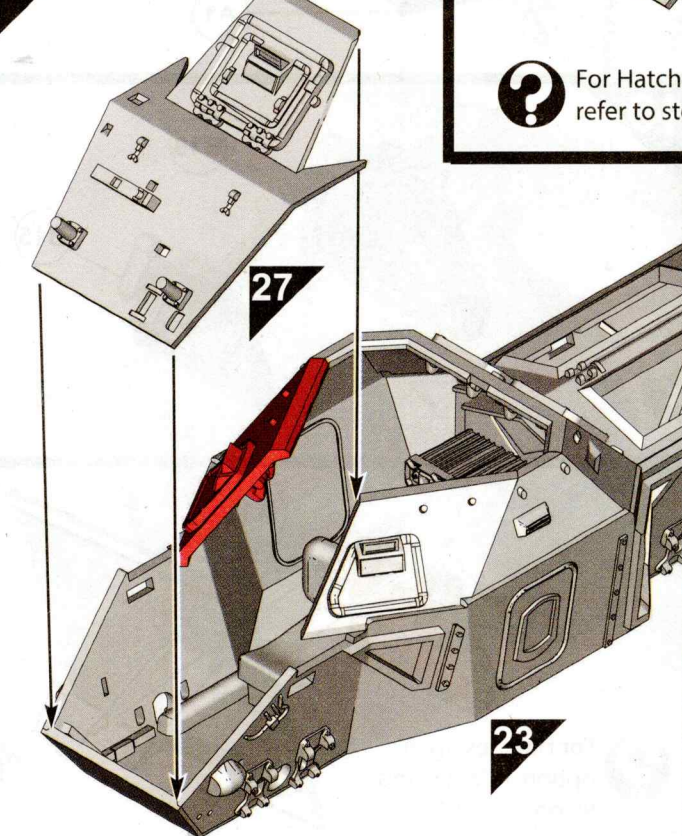

29

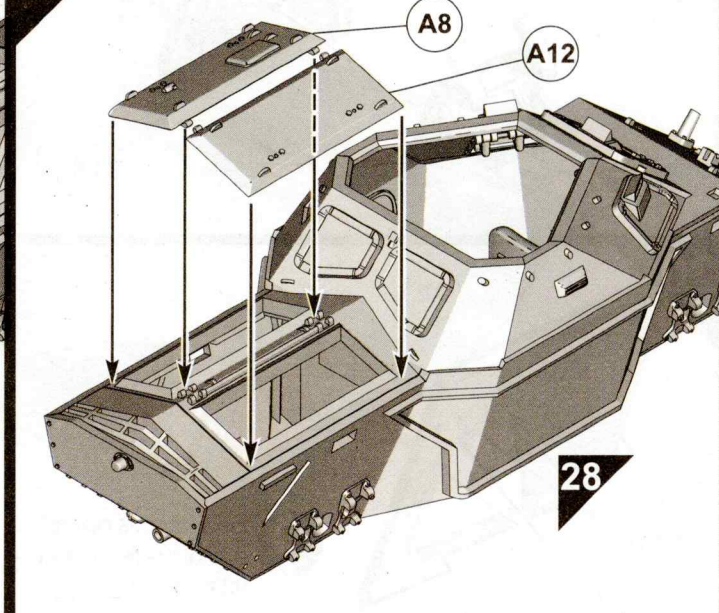

? For Hatches open option, refer to step 98 on page 17.

30

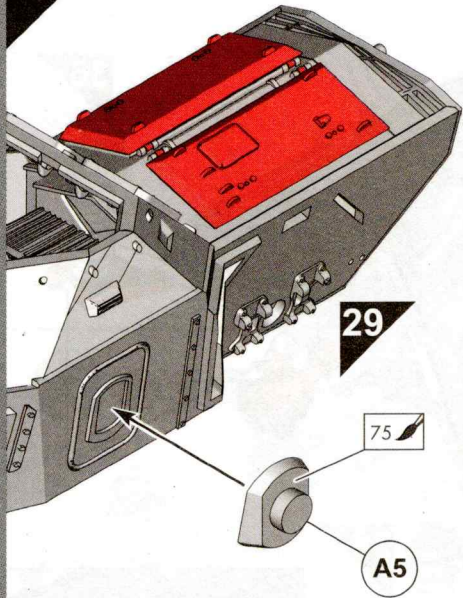

31

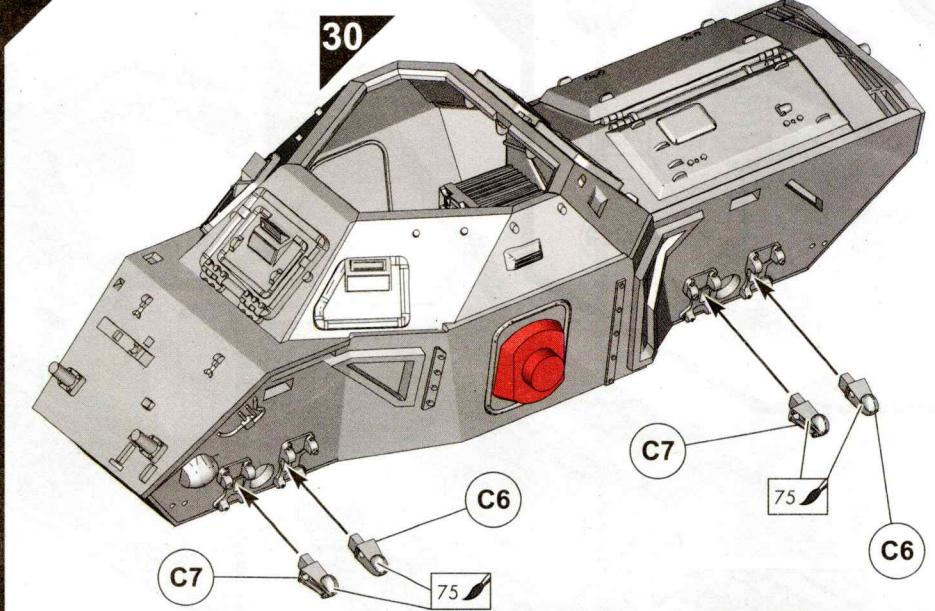

32

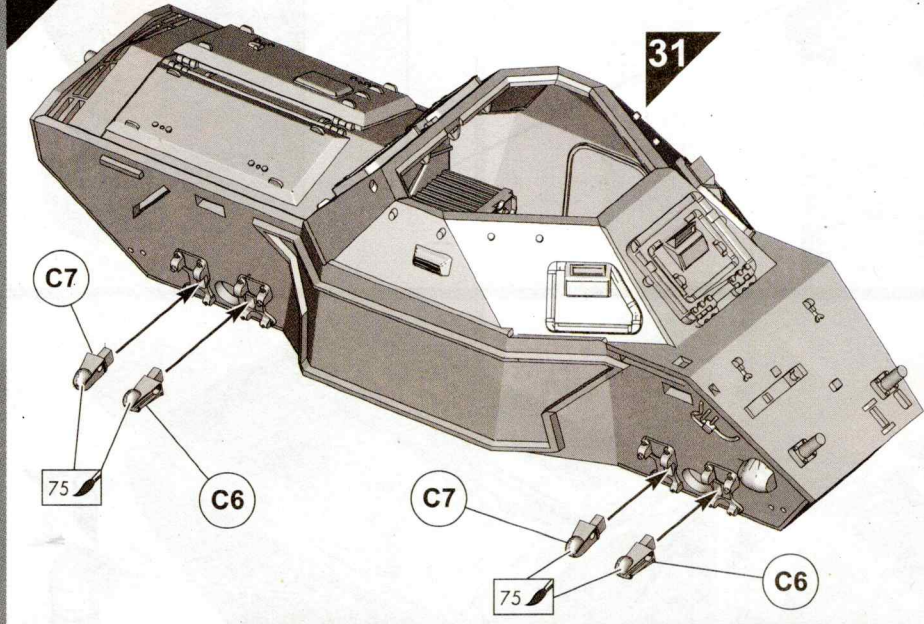

33

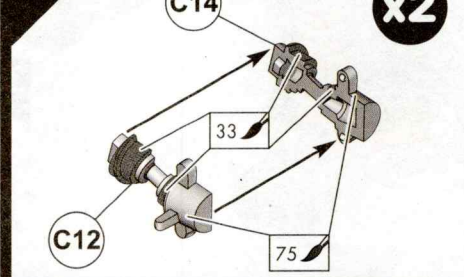

34

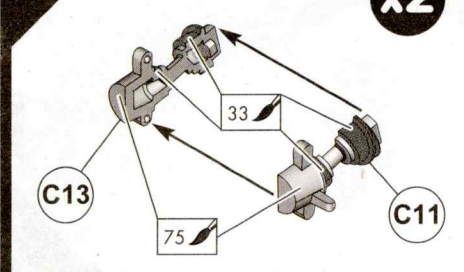

35

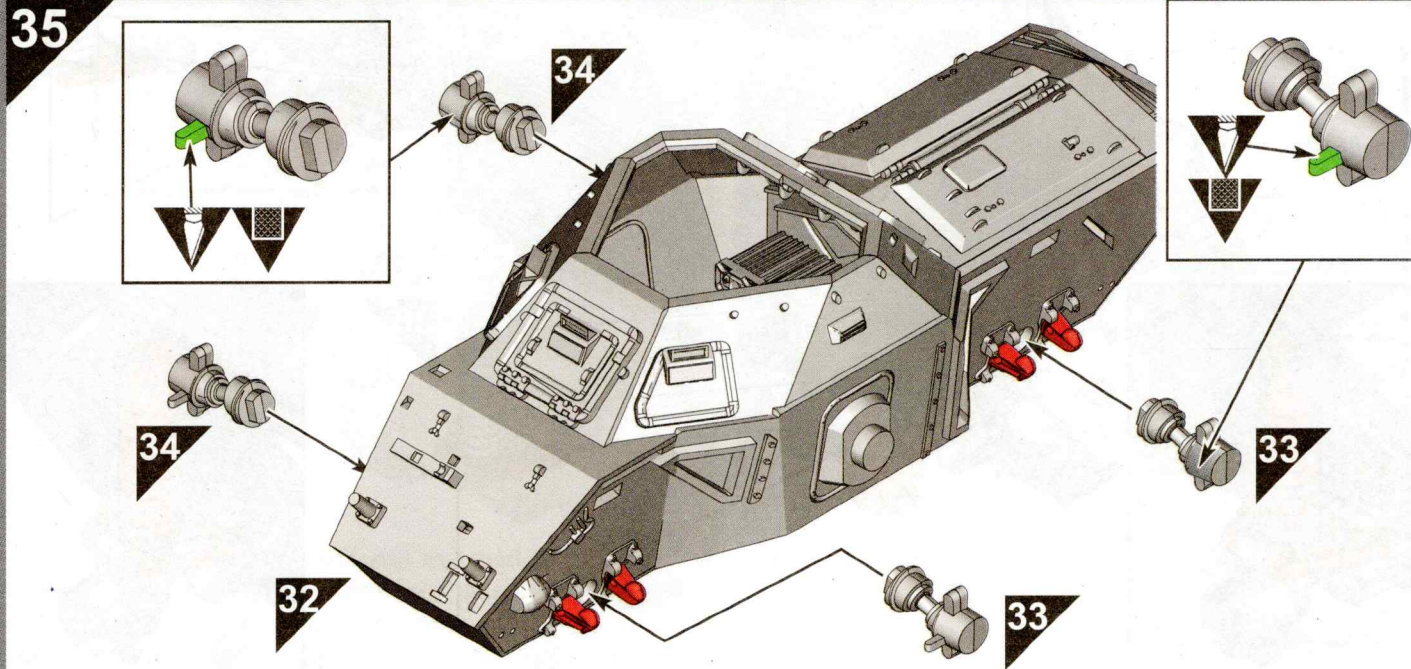

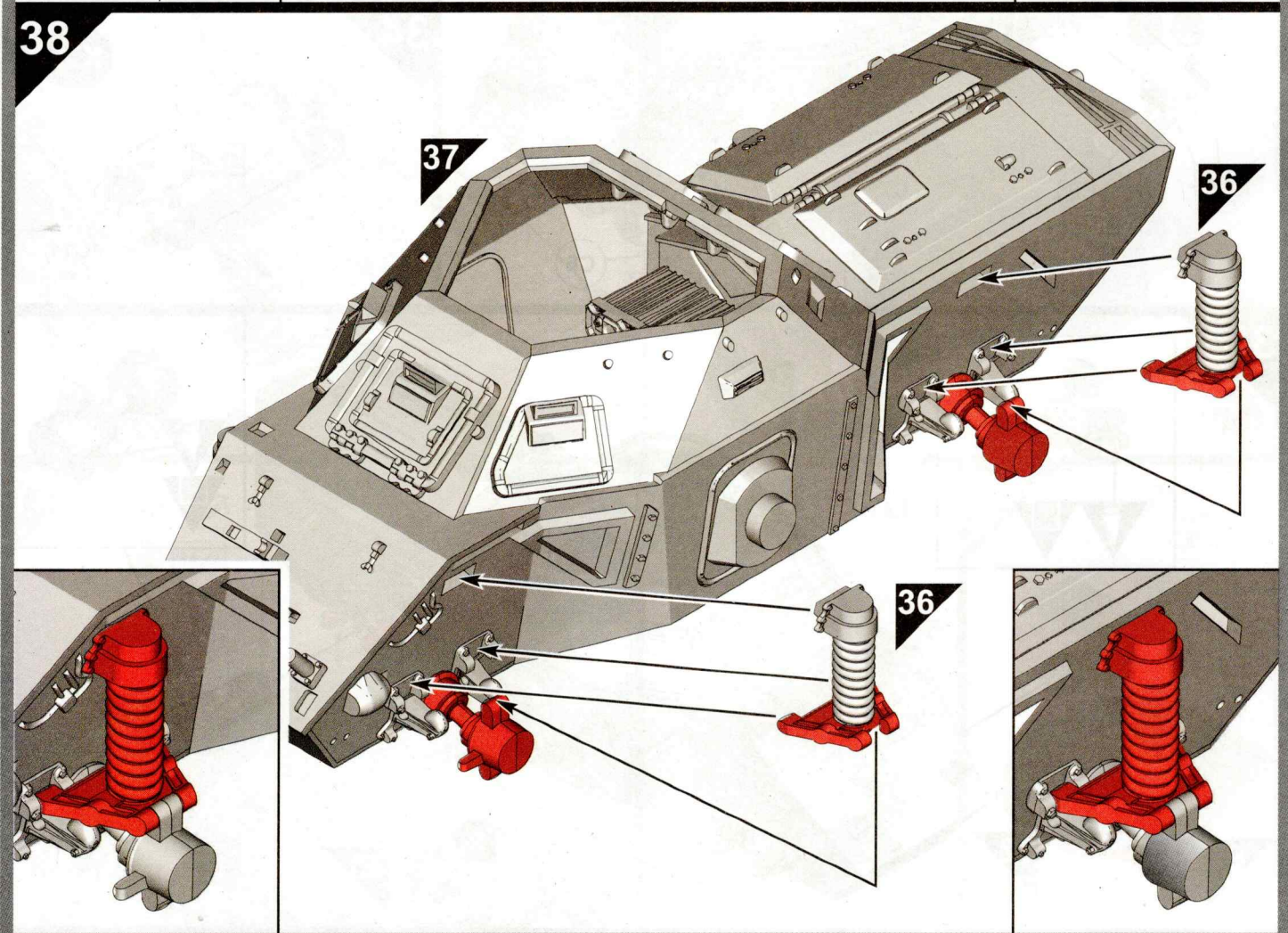
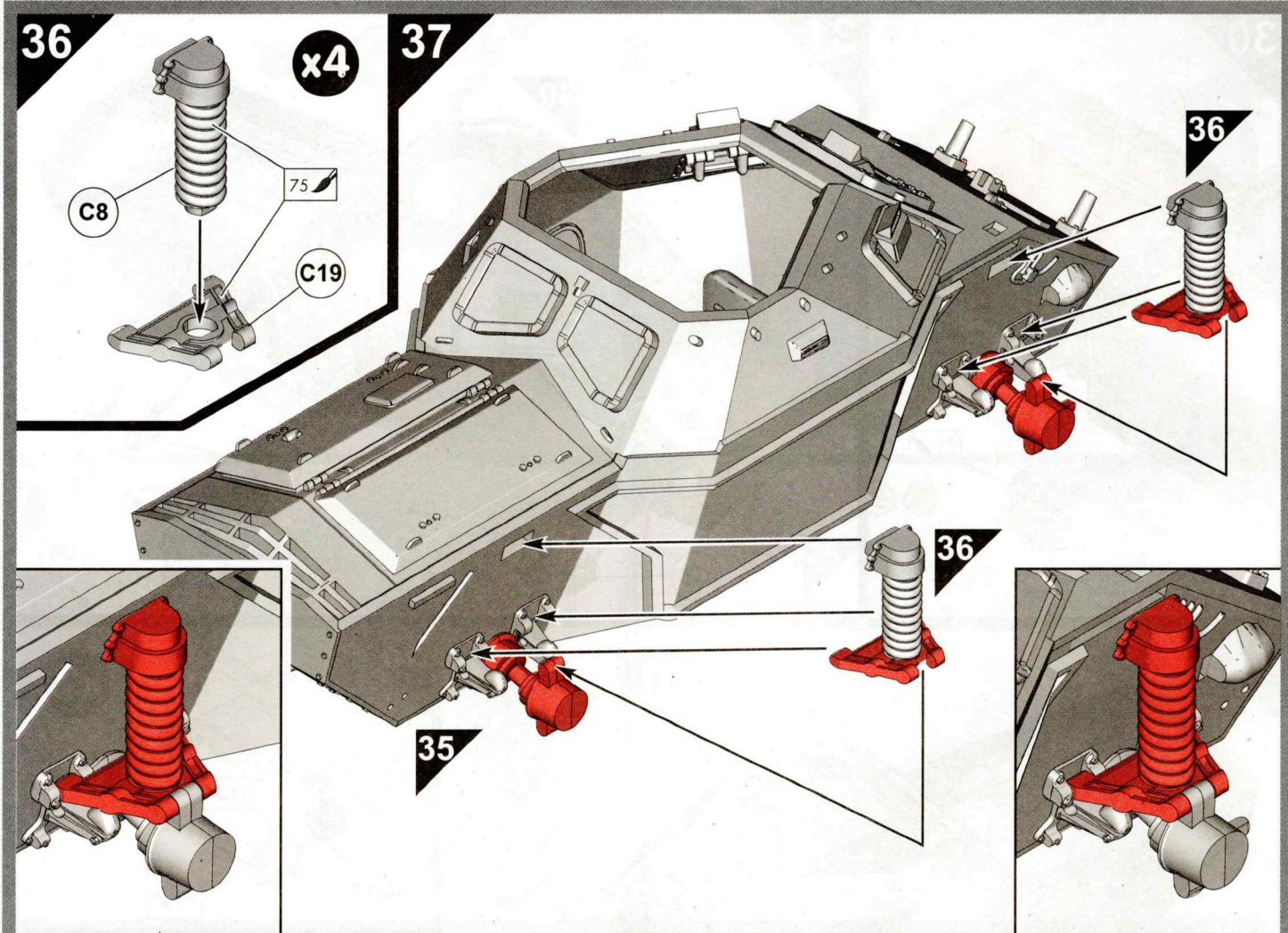

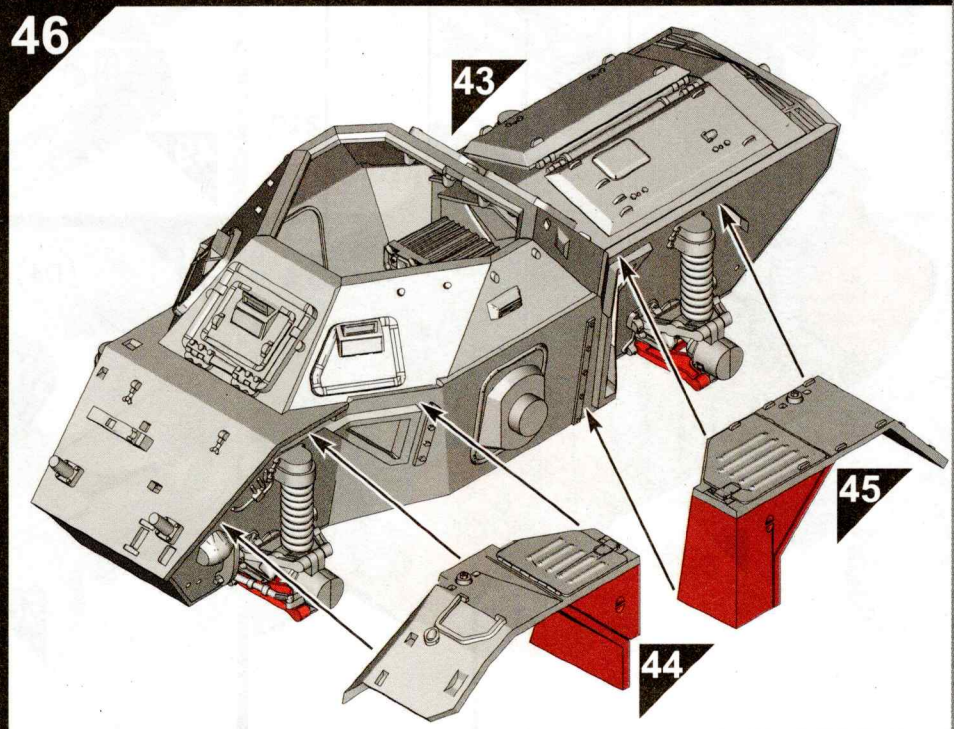
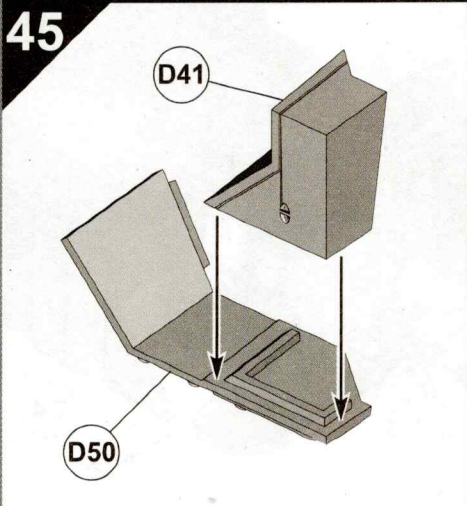
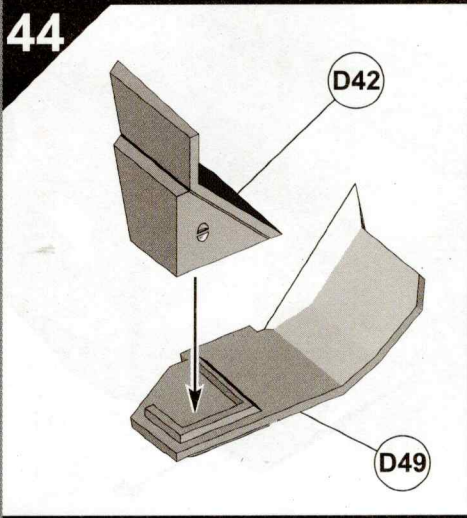
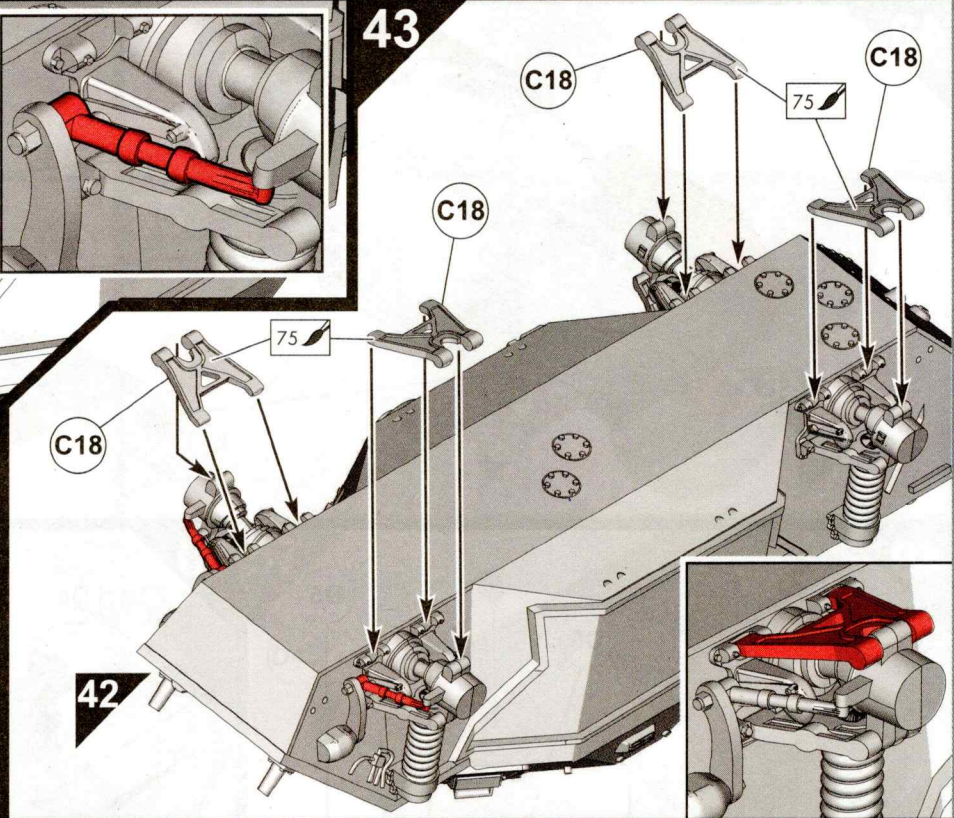
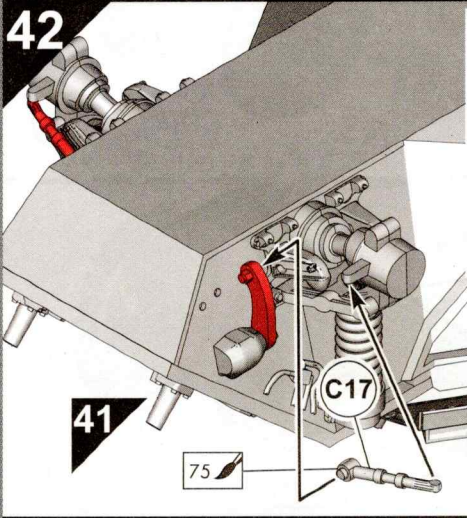
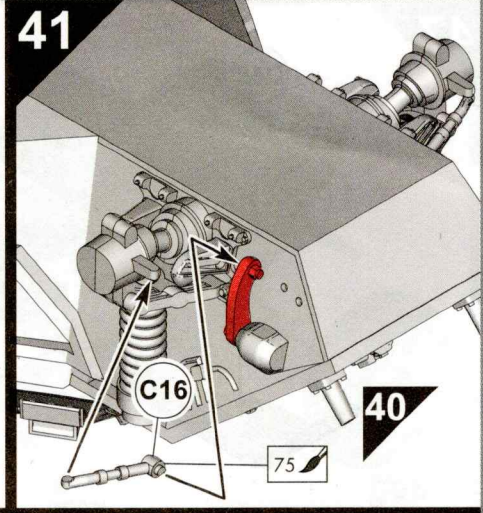
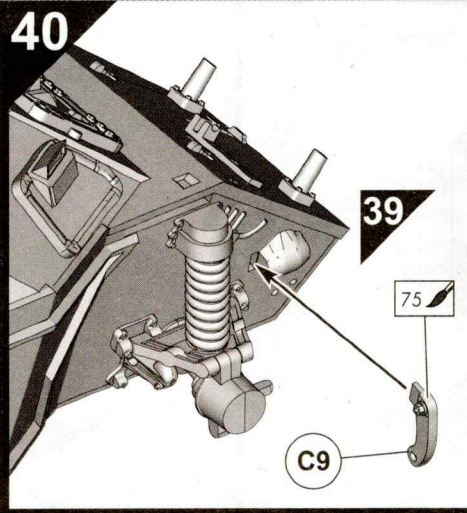
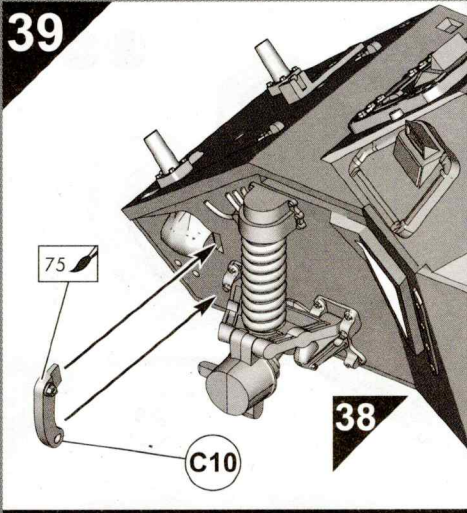

47

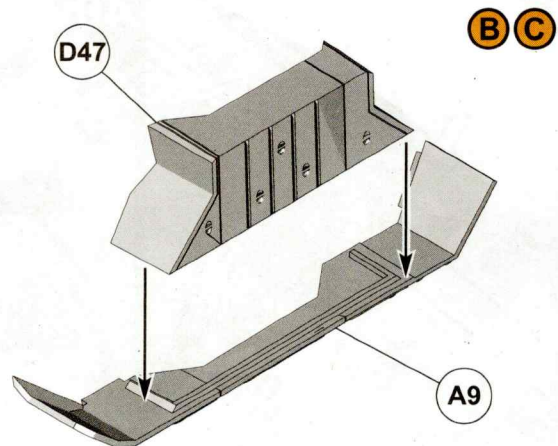
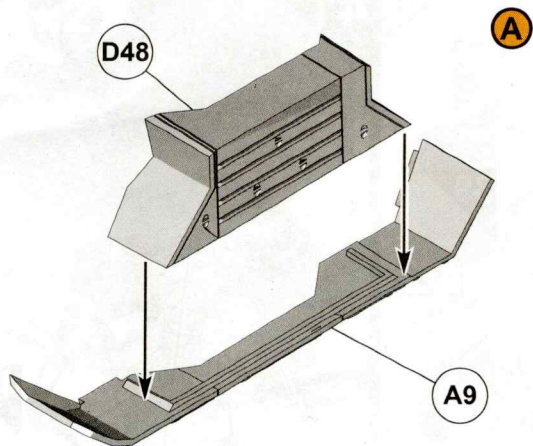

48

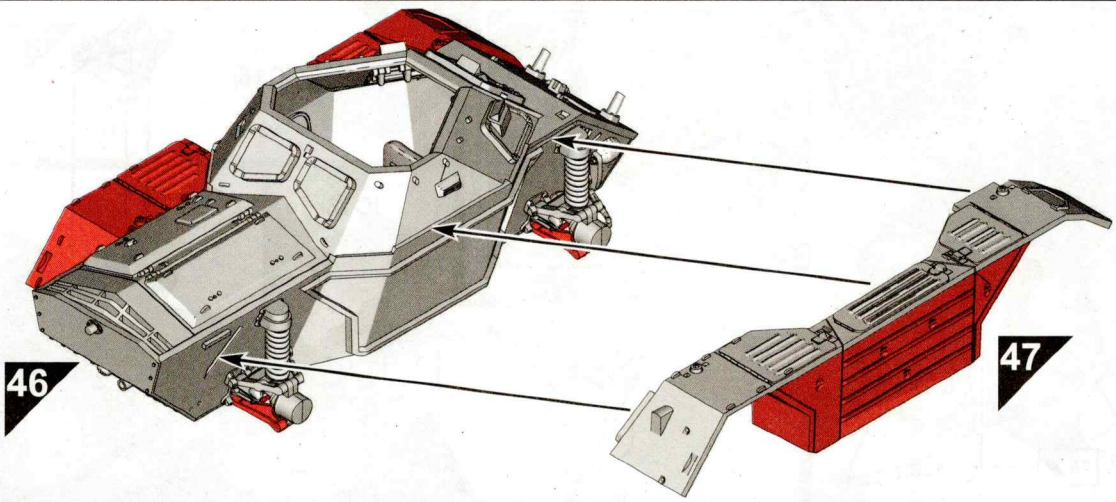

49

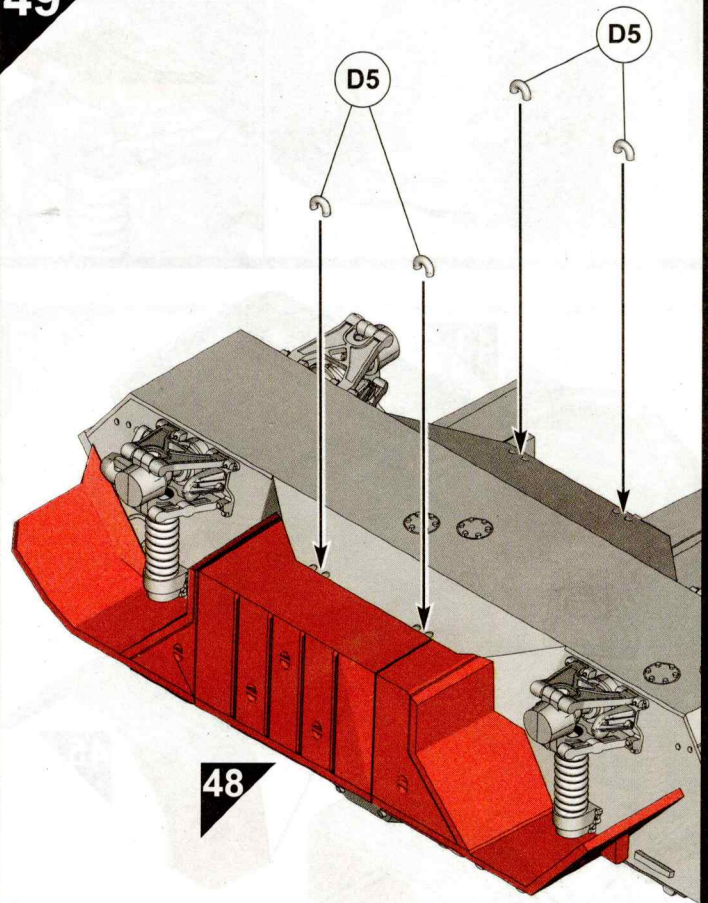

50

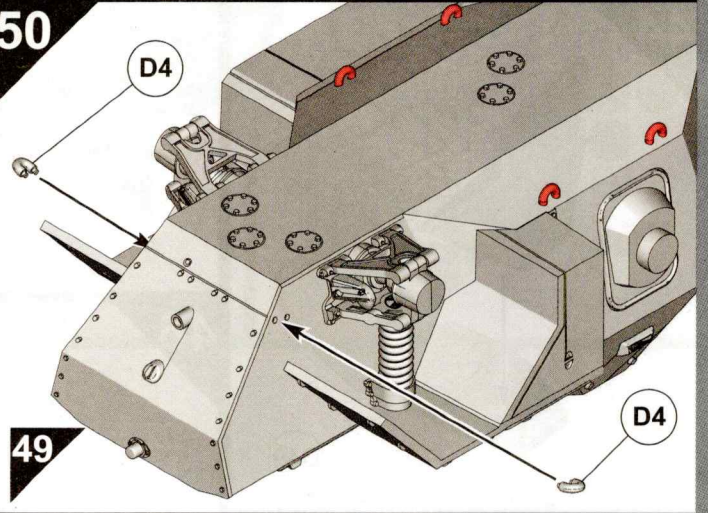

51

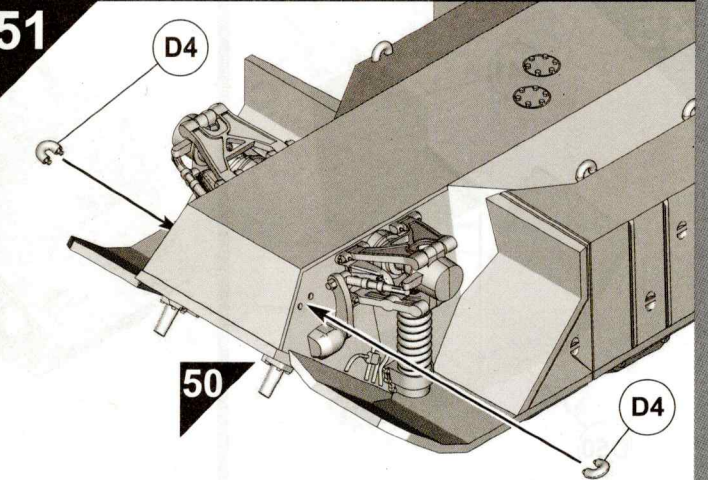

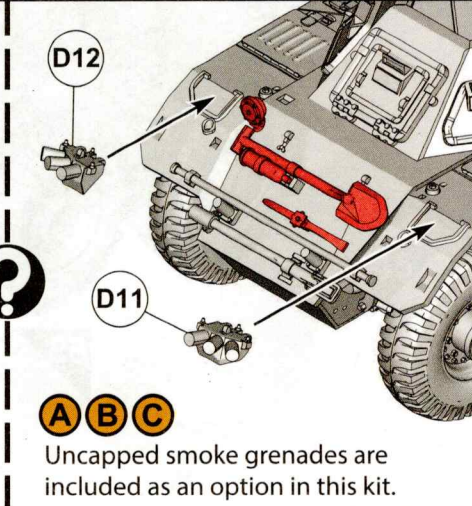
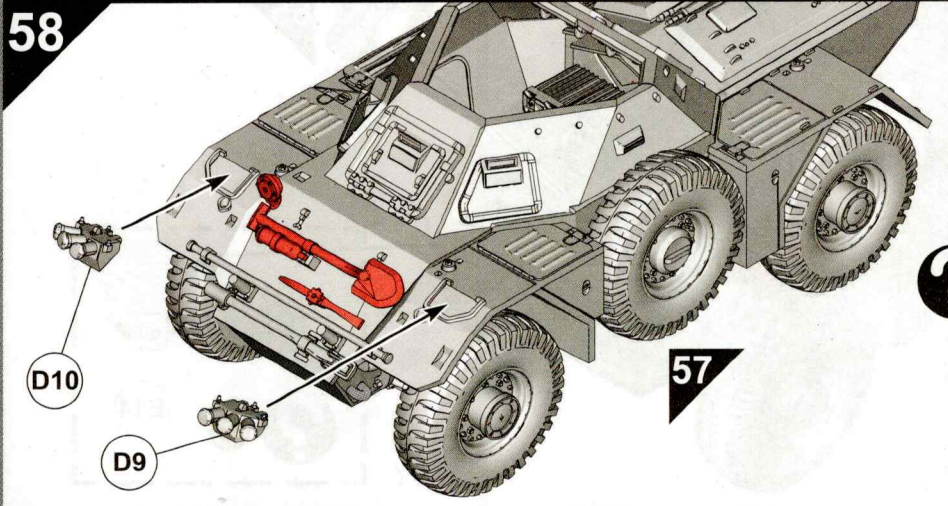
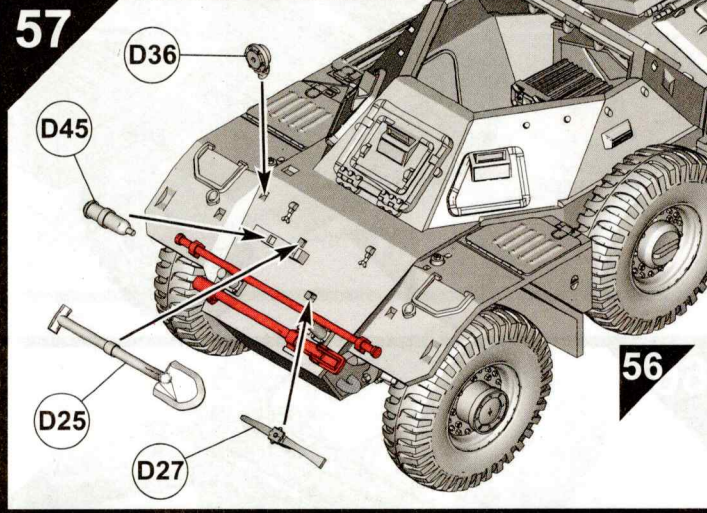
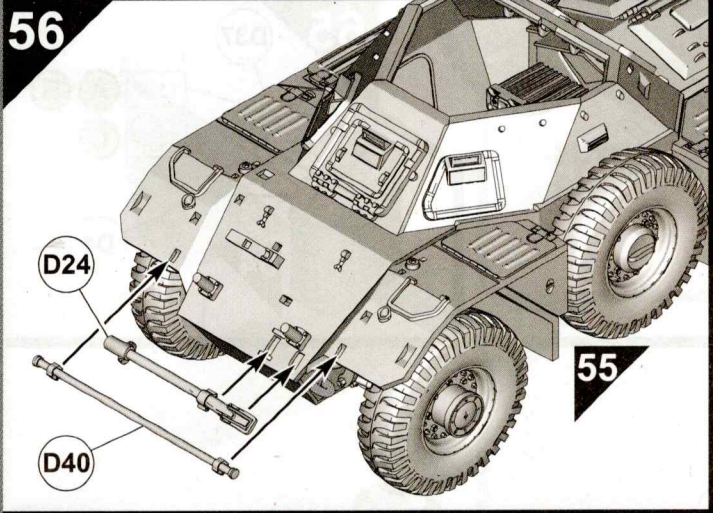
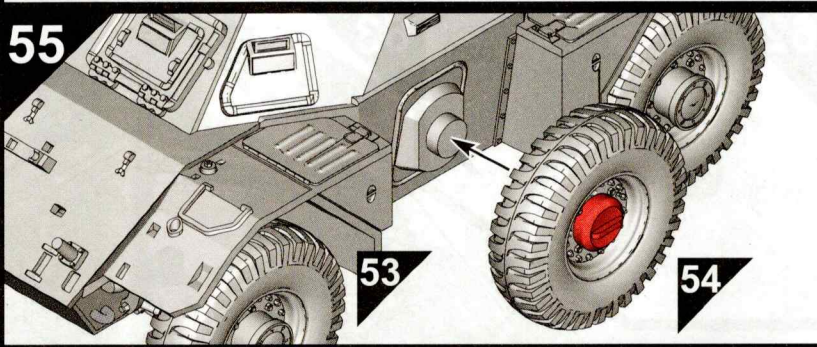
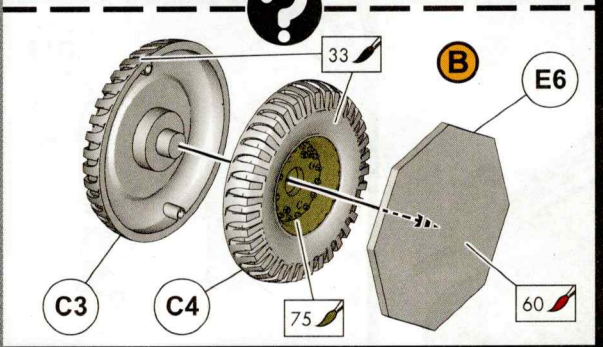
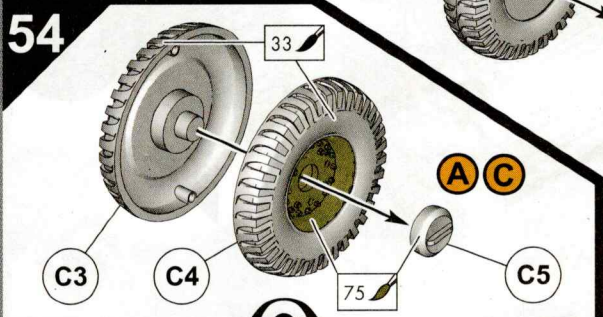
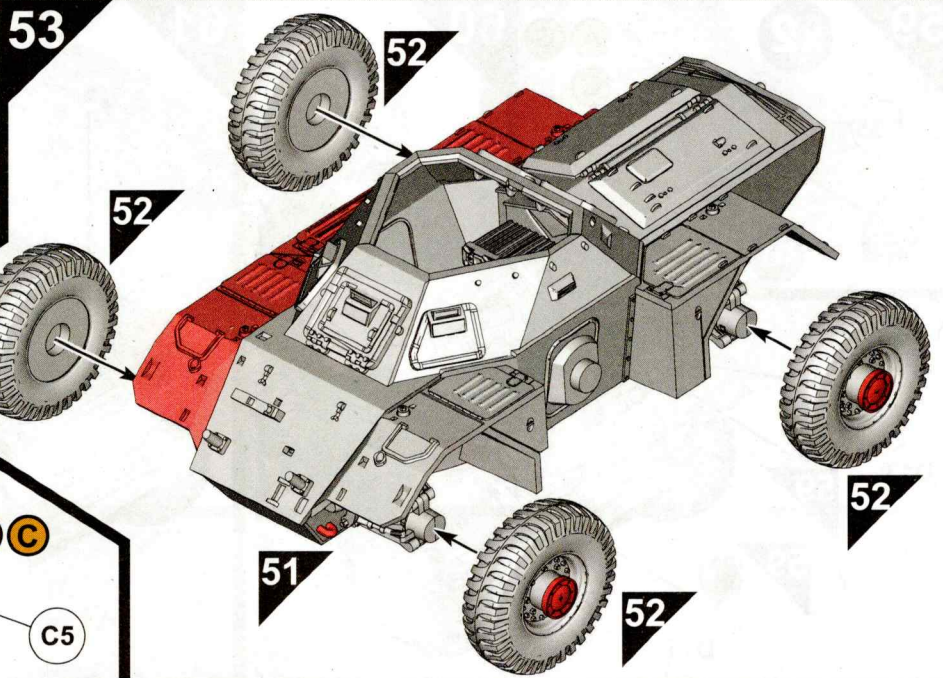
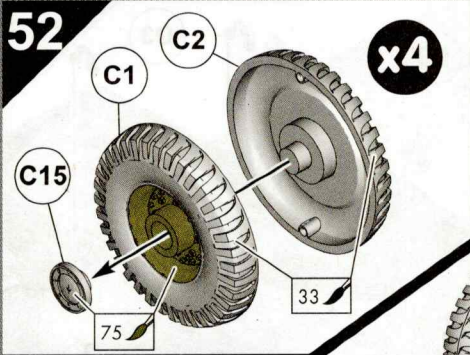

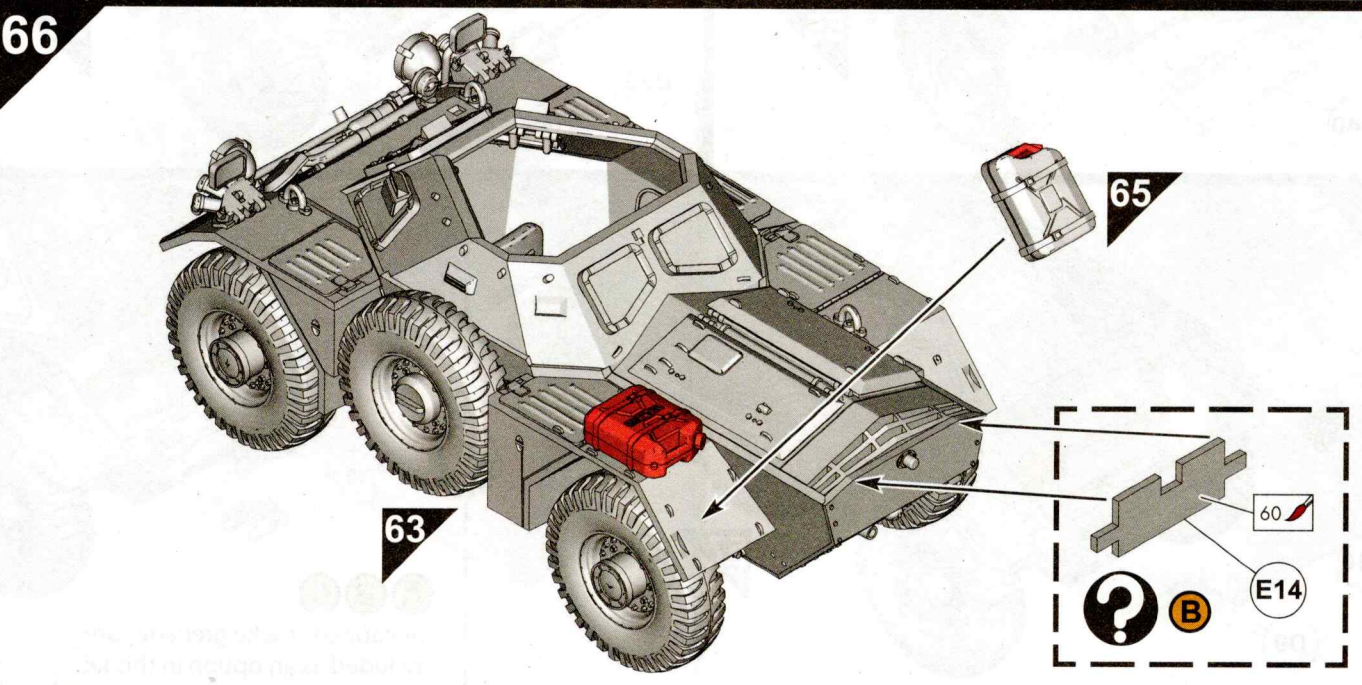
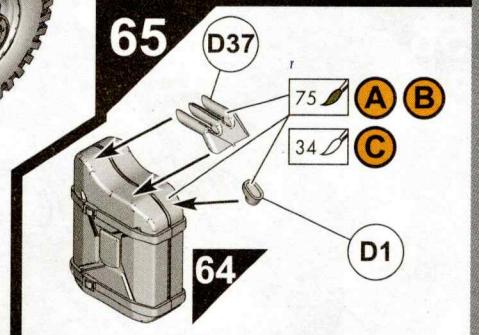
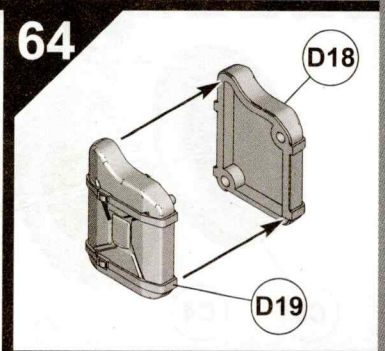
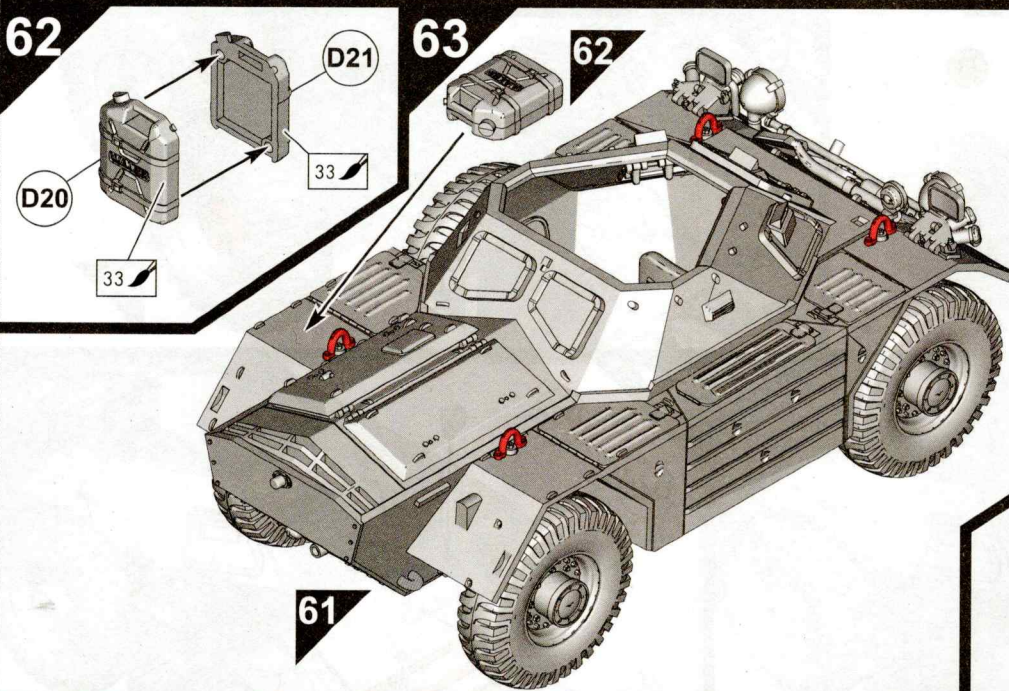
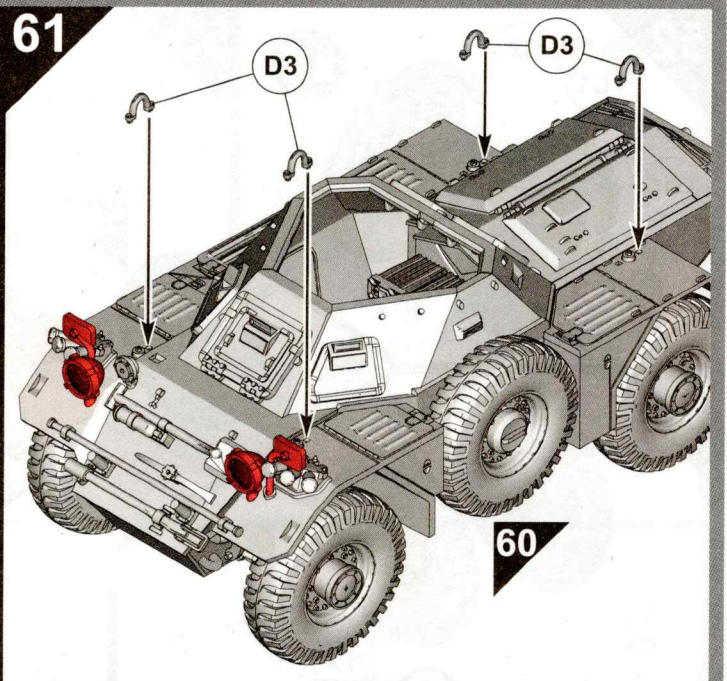
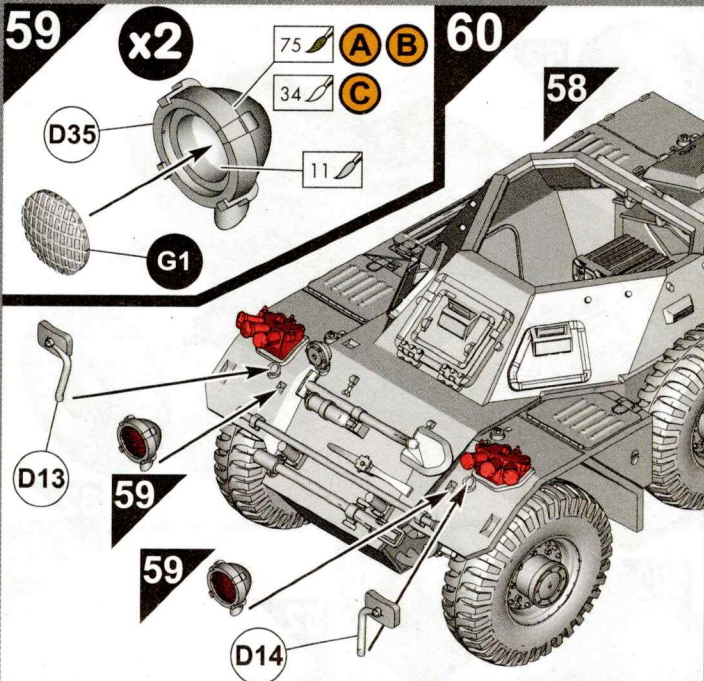

67

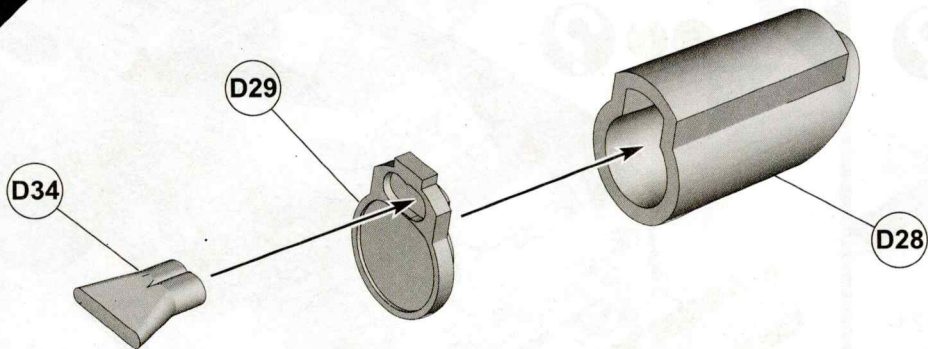

69



68

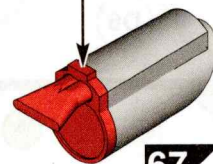

67



A B C

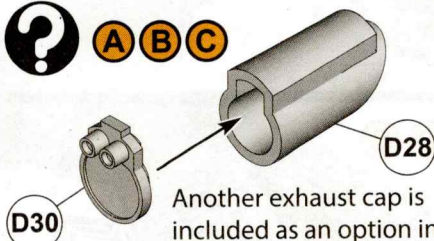

Another exhaust cap is included as an option in this kit.

68

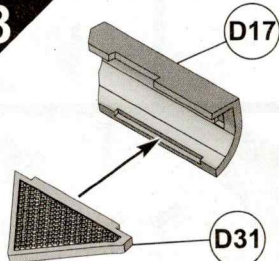

70

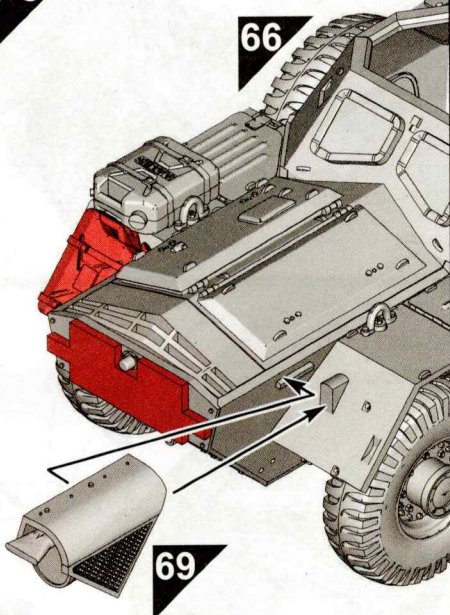

66

69

71

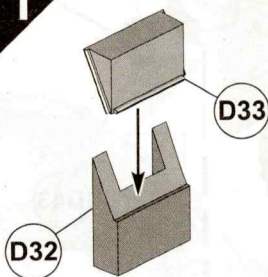

70

72

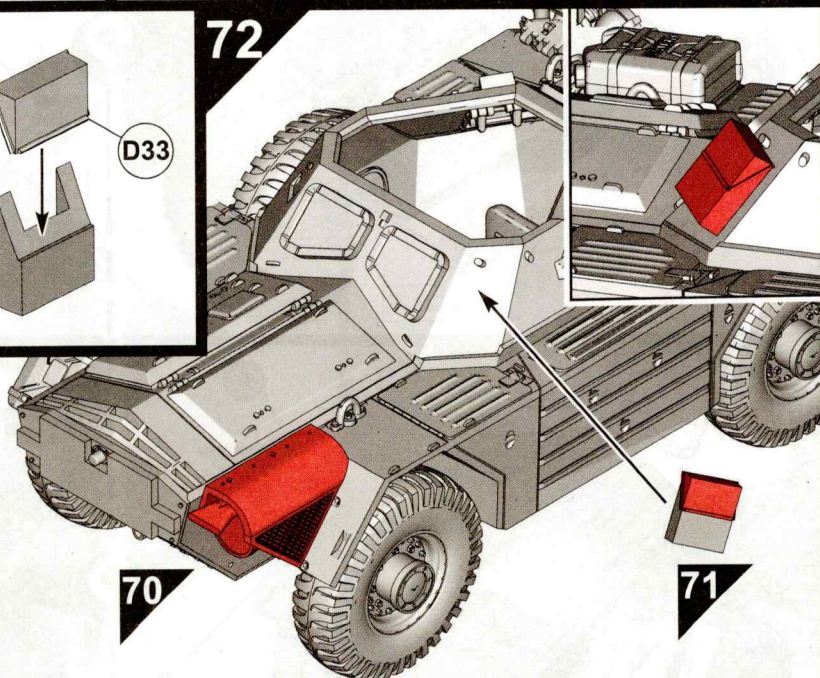

71

73

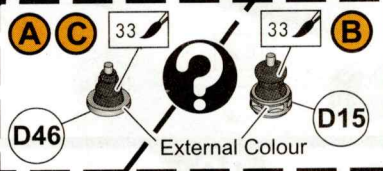

72

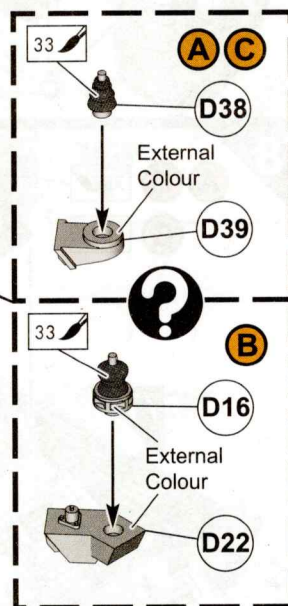
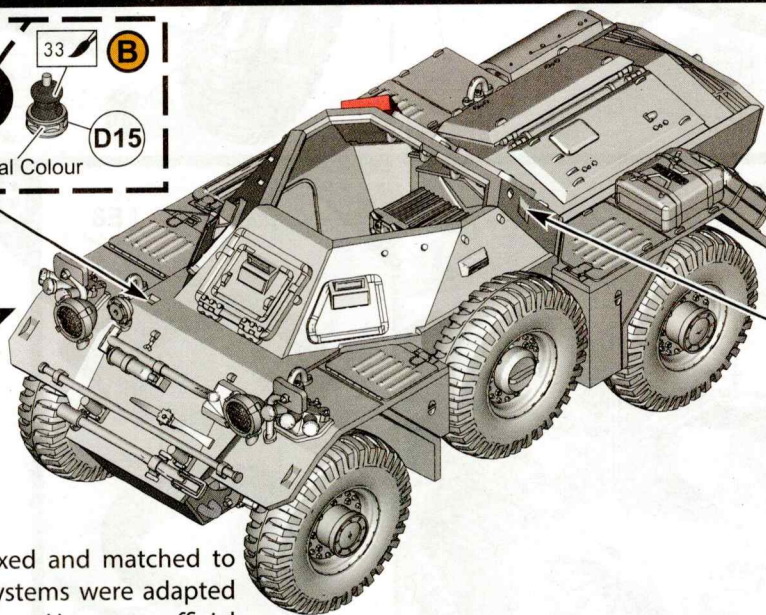

These antenna can be mixed and matched to users reference, as radio systems were adapted to what mounts were there. However, official larkspur setup is **A** & **C** and clansmen is **B**

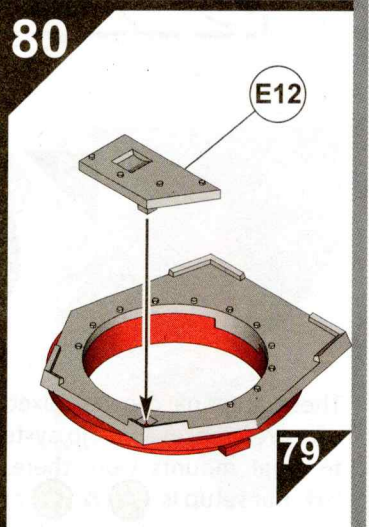
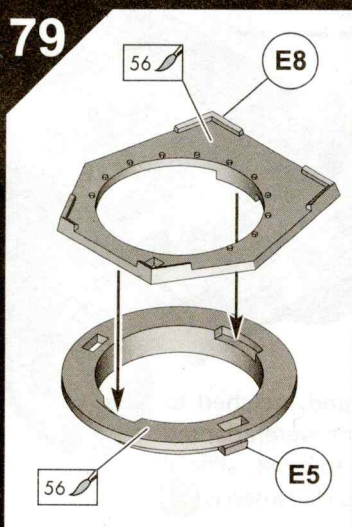
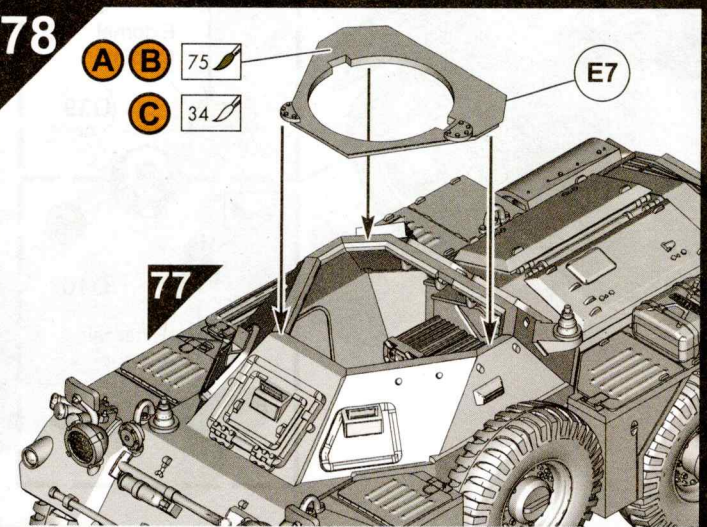
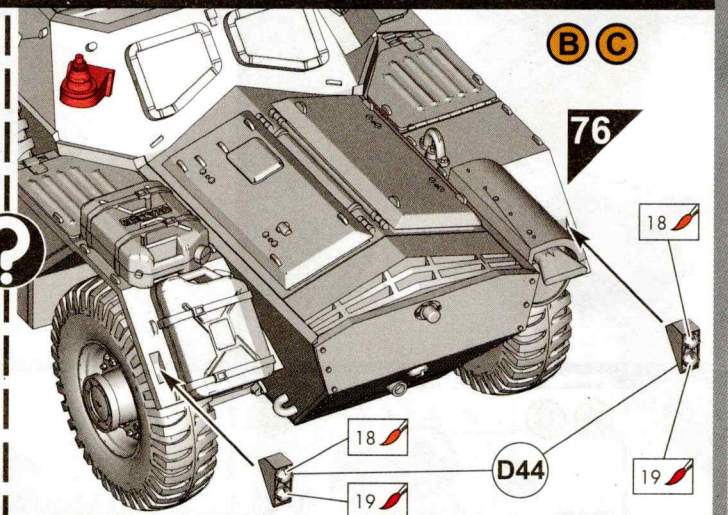
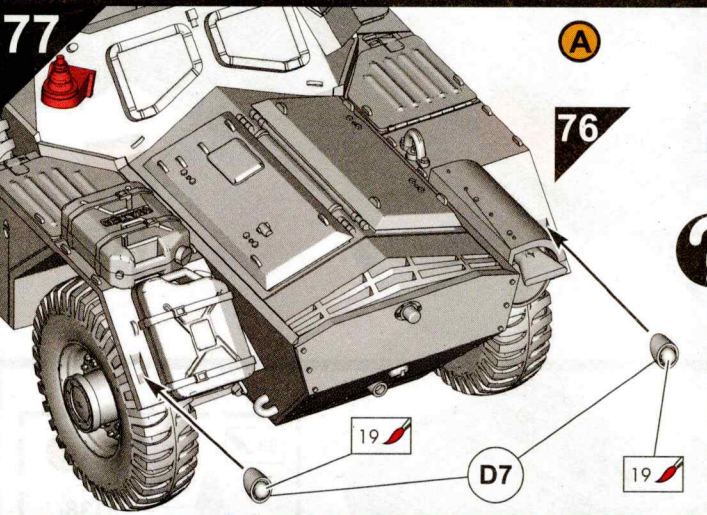
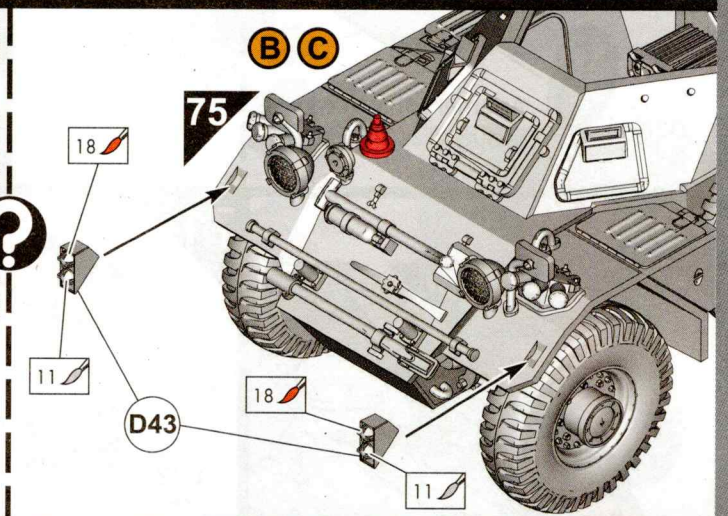
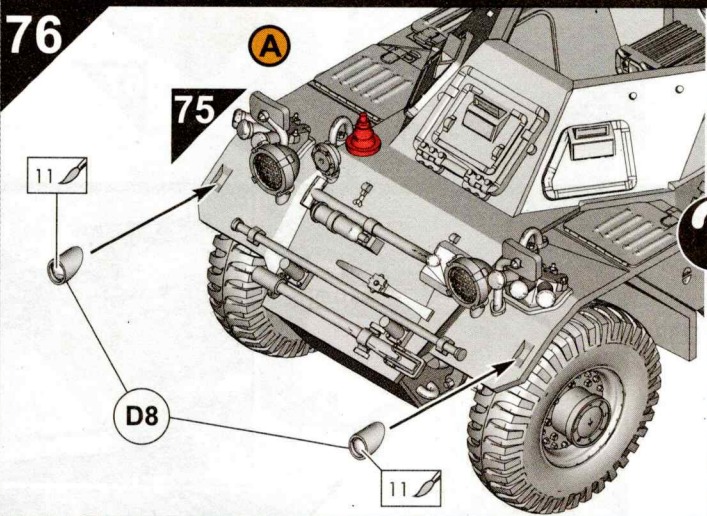
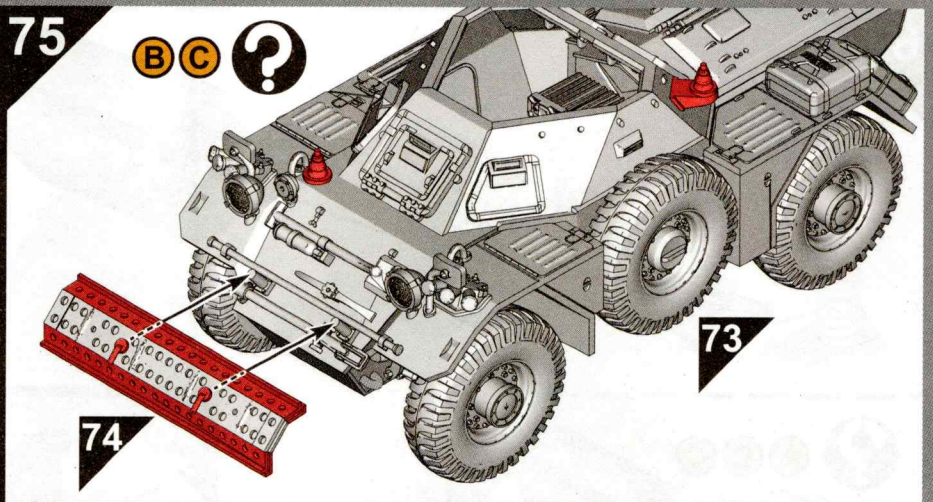
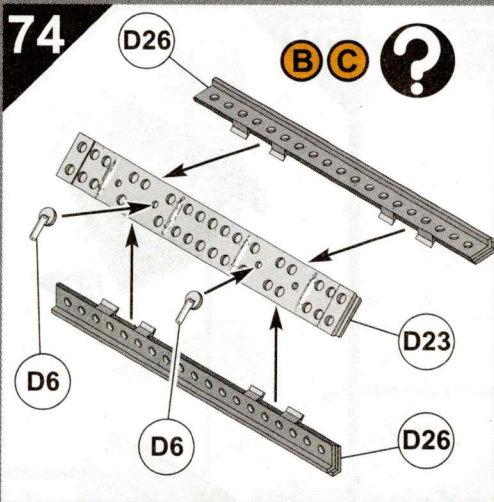

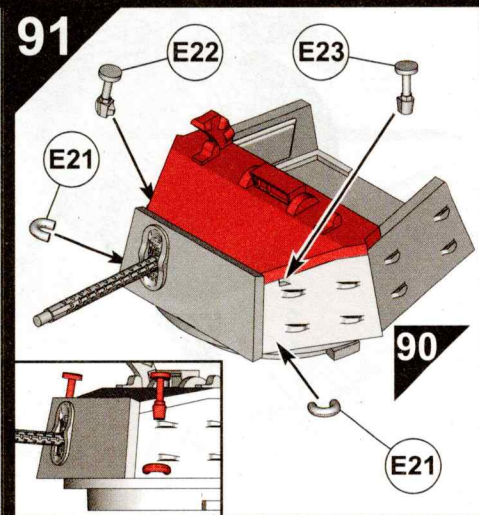
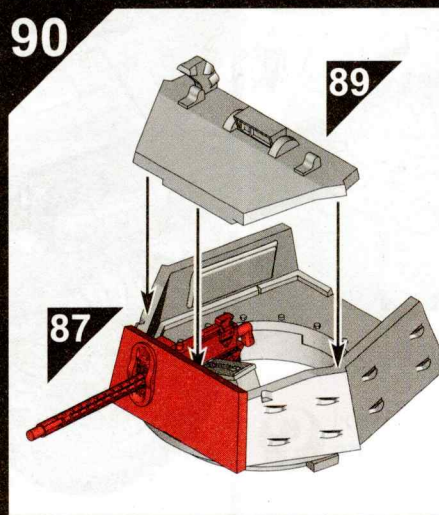
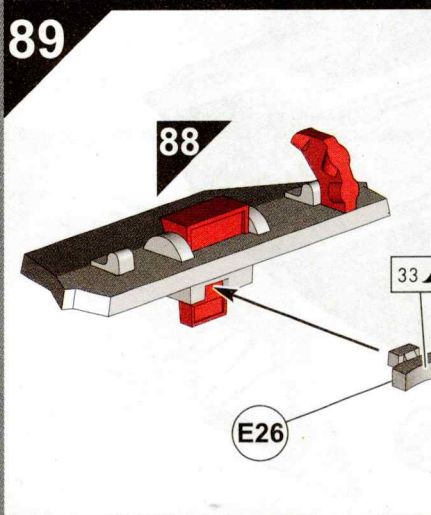
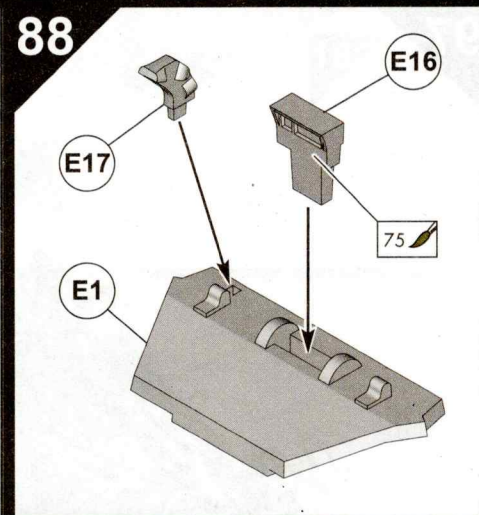
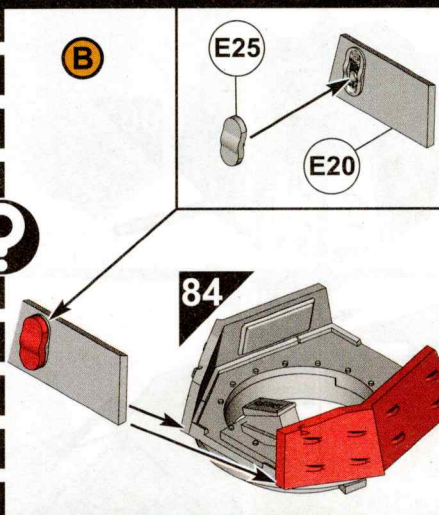
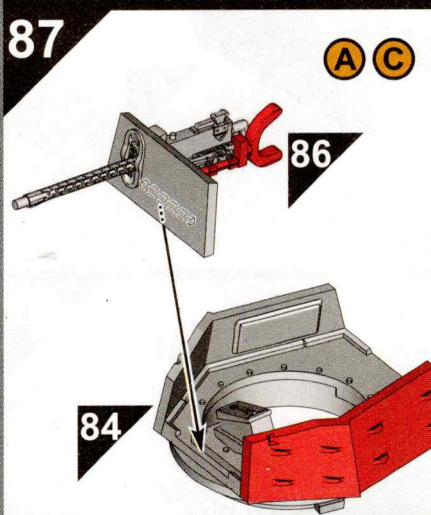
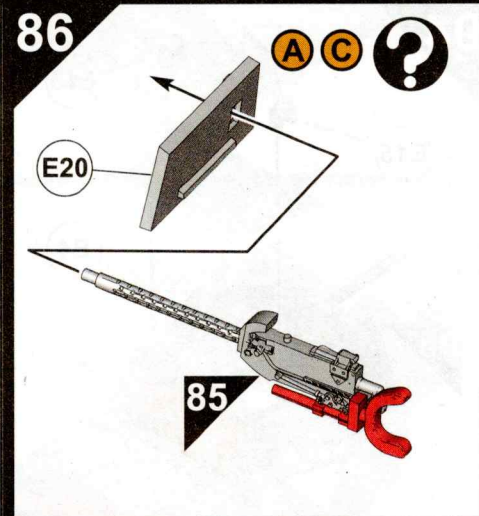
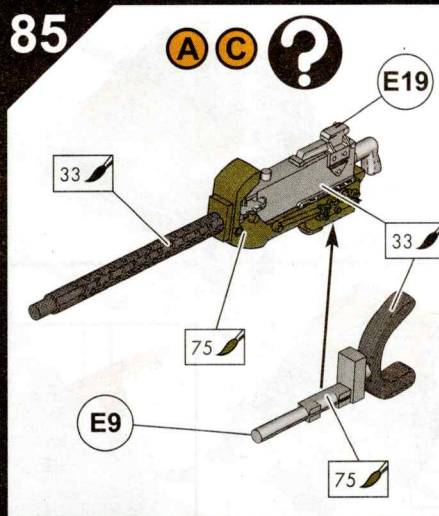
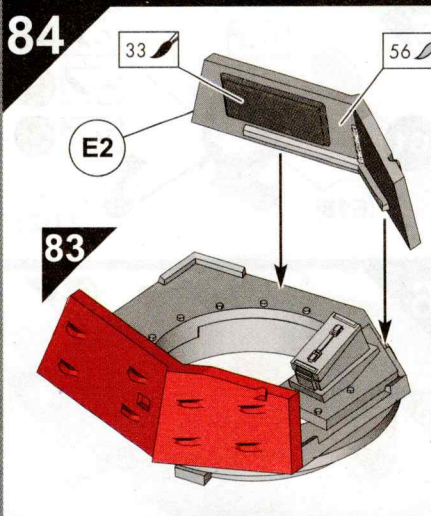
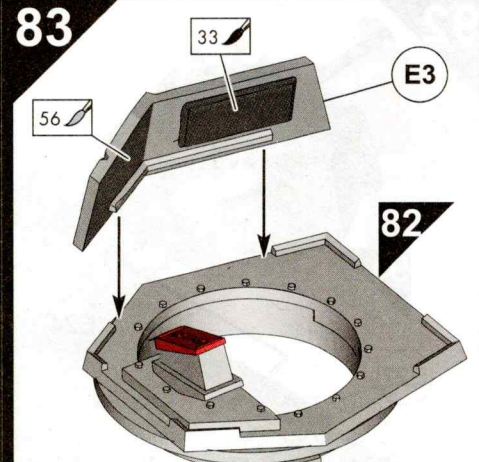
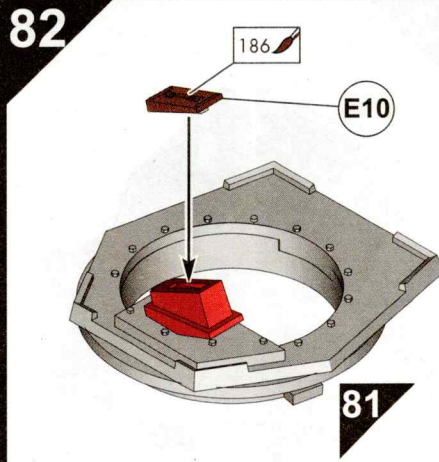
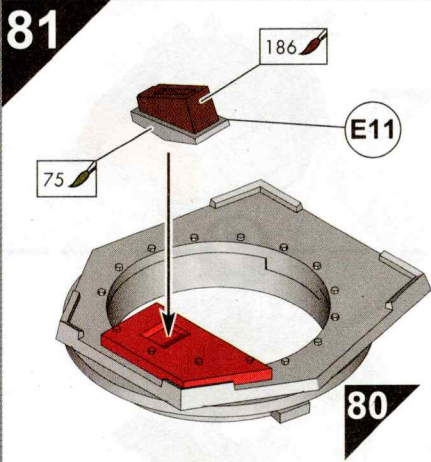

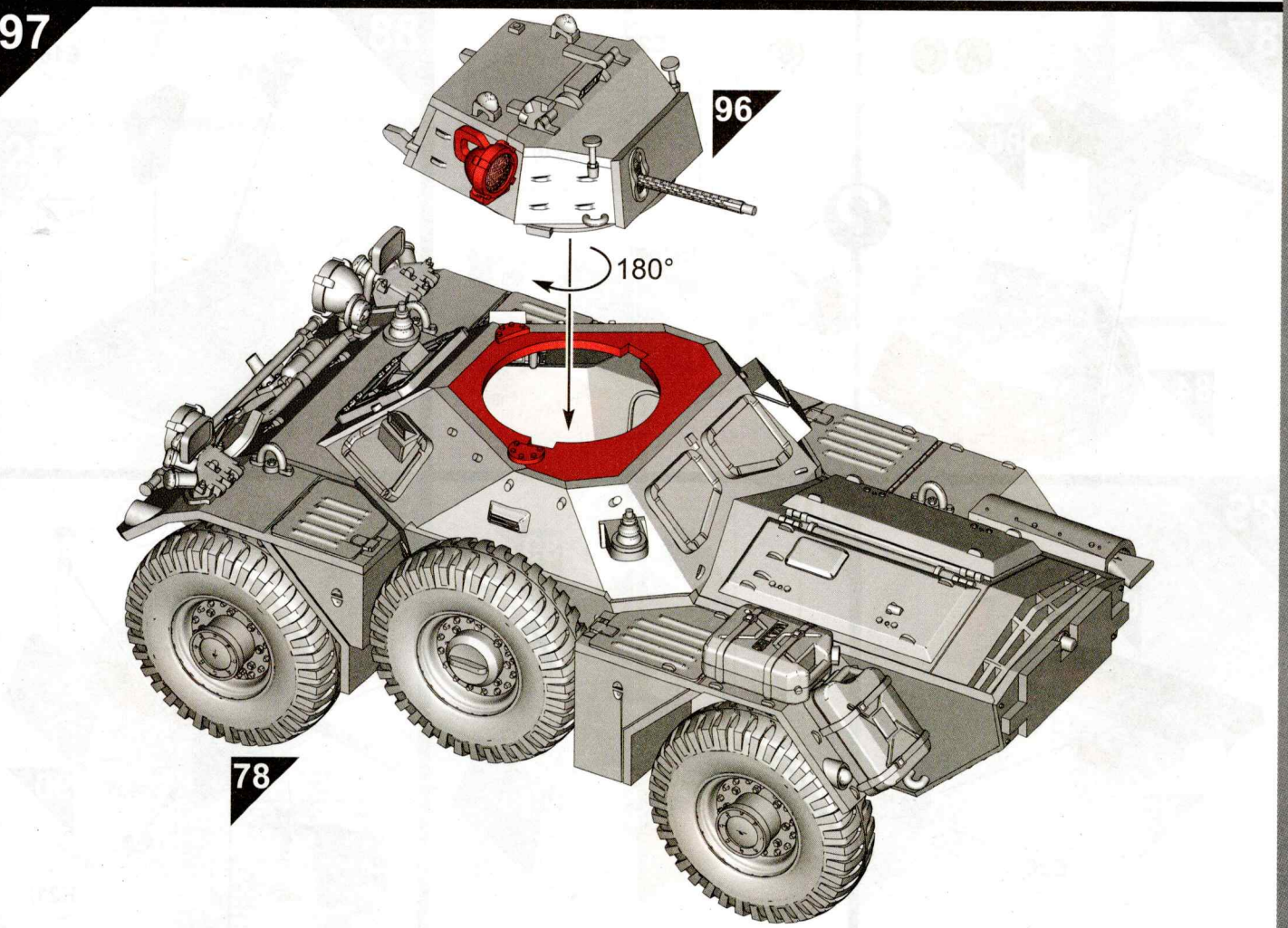
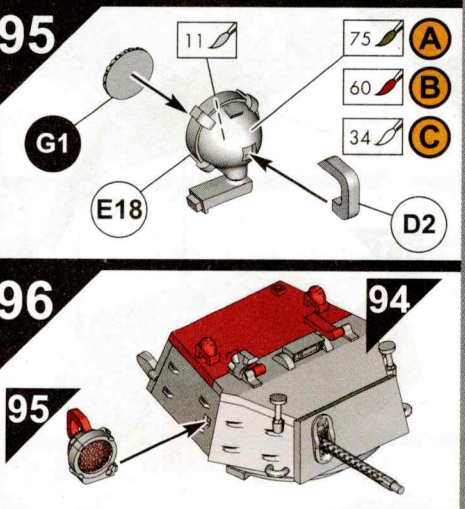
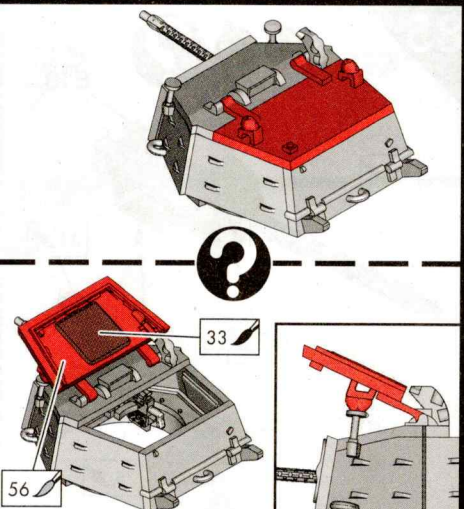
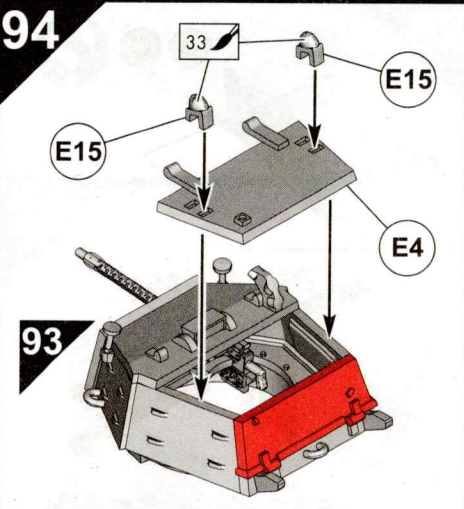
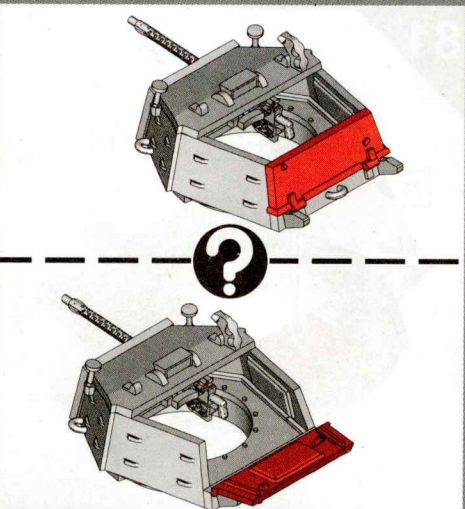
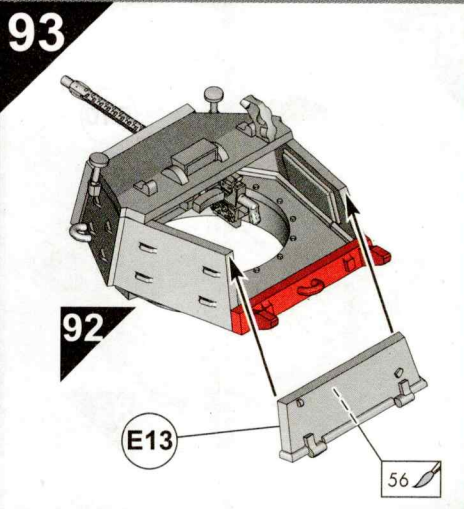
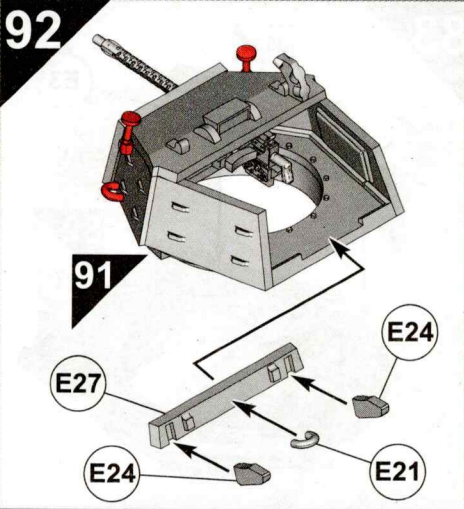



A B C

This page shows the option of how all the hatches can be assembled in their open position.

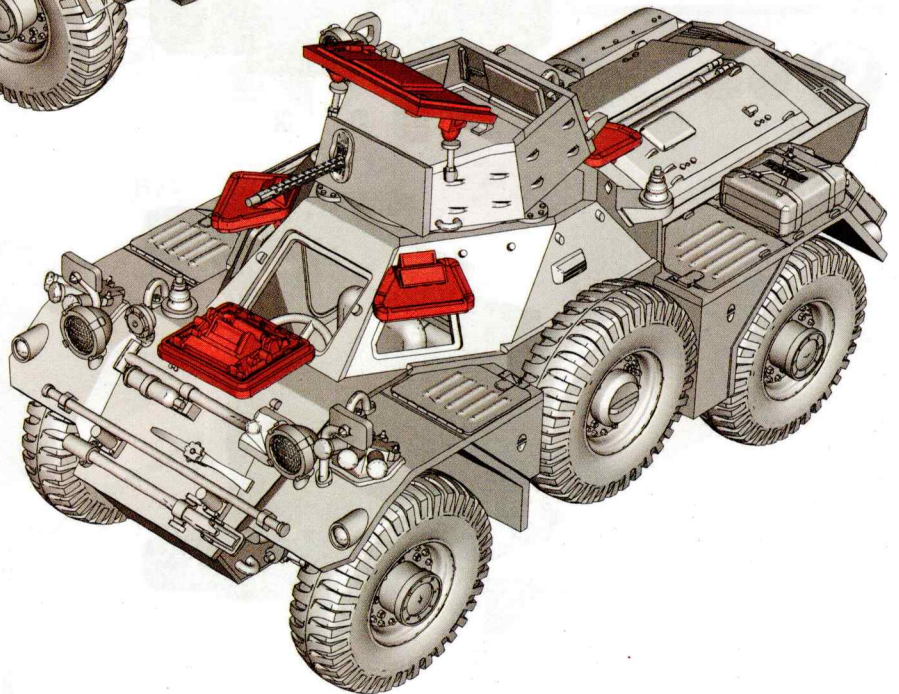
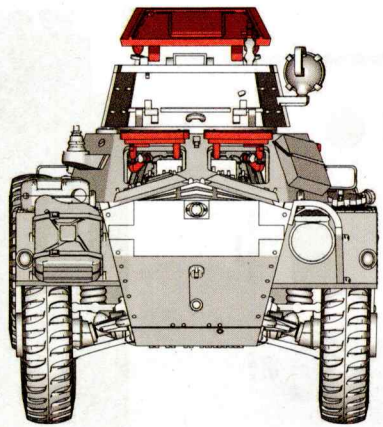
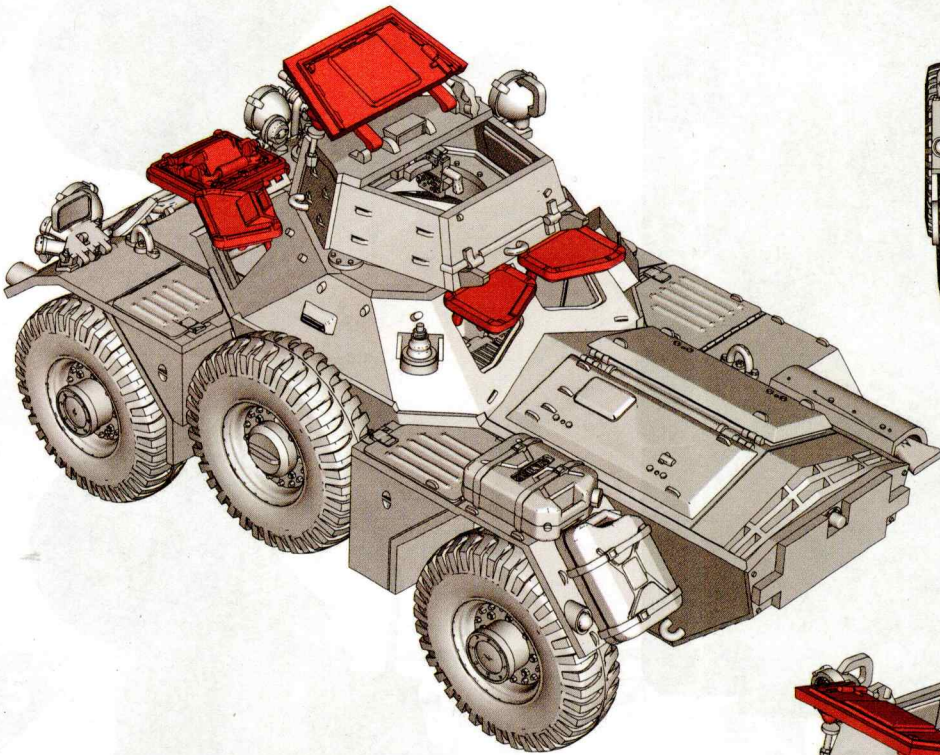
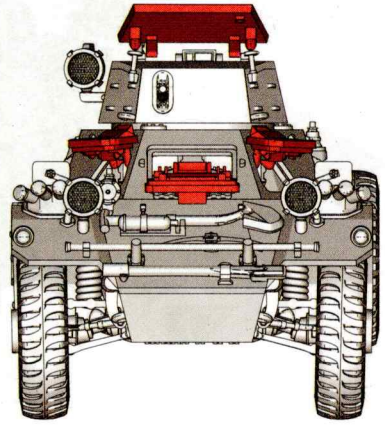
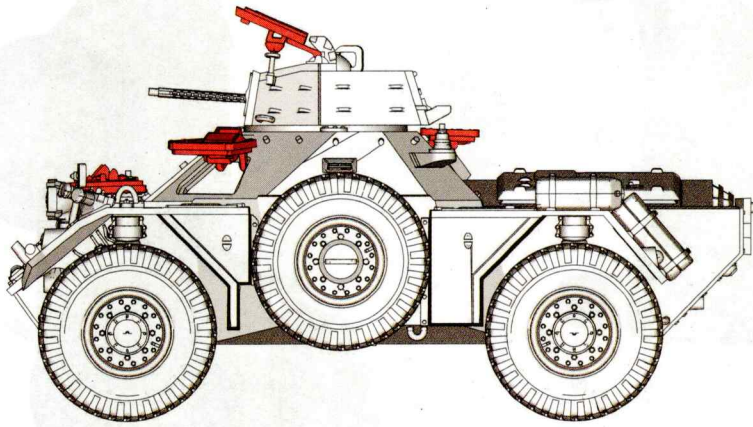

A Ferret Scout Car Mk.2
 West Germany, August 1961.

- 11 Silver
- 29 Dark Earth
- 33 Matt Black
- 53 Gun Metal
- 75 Matt Bronze Green

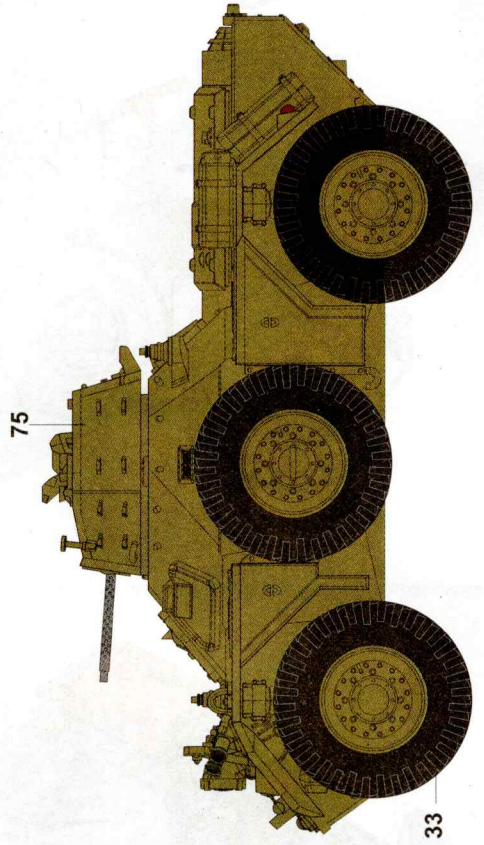
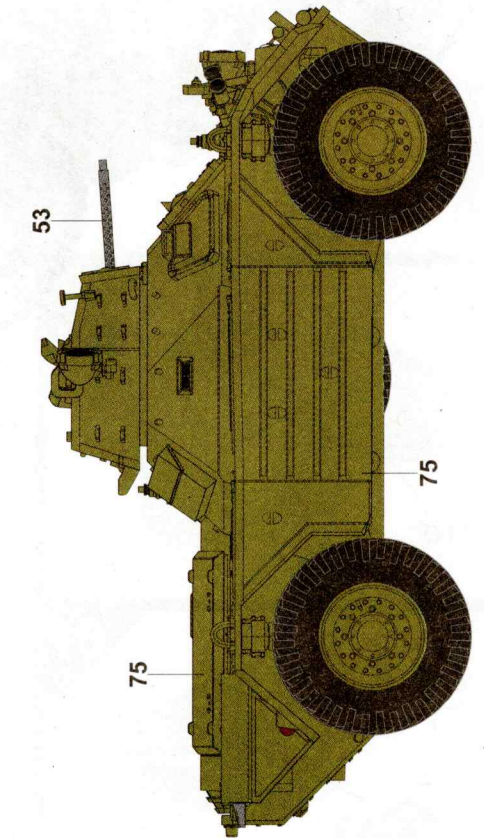
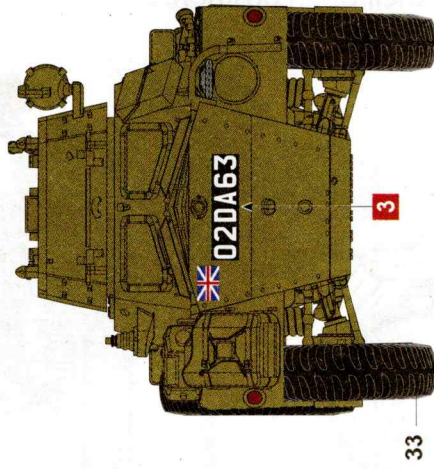
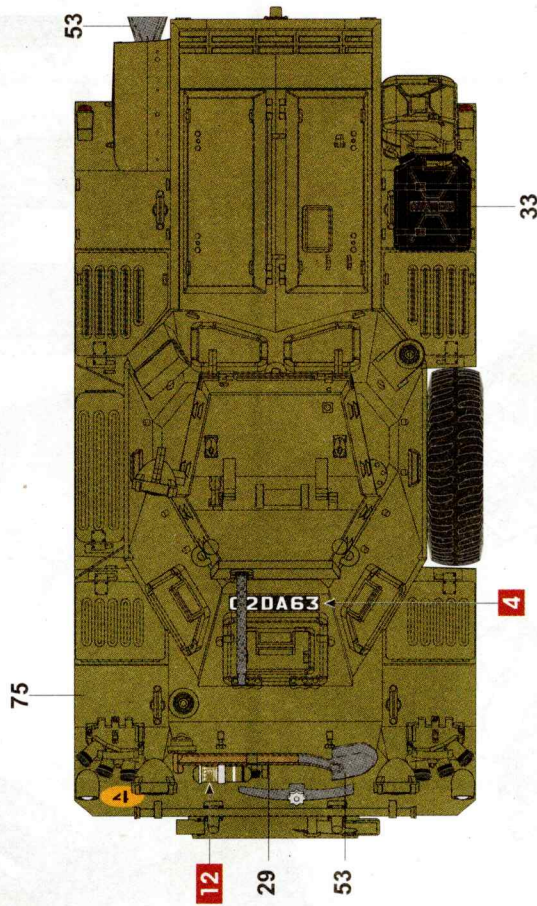
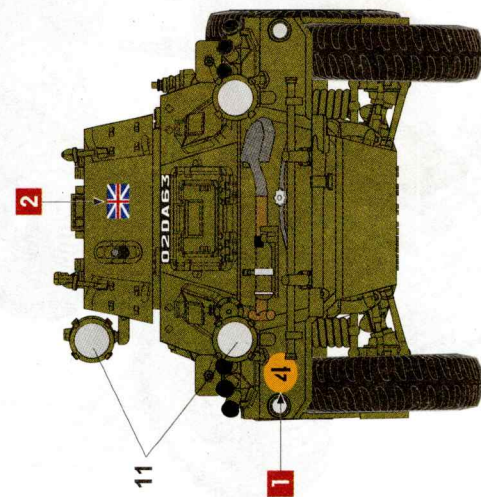

B Ferret Scout Car Mk.2
 British Army Training Unit Suffield (BATUS), Canadian Forces Base Suffield, Alberta, Canada, 1980s.

- 11 Silver
- 29 Dark Earth
- 33 Matt Black
- 53 Gun Metal
- 60 Matt Scarlet
- 75 Matt Bronze Green

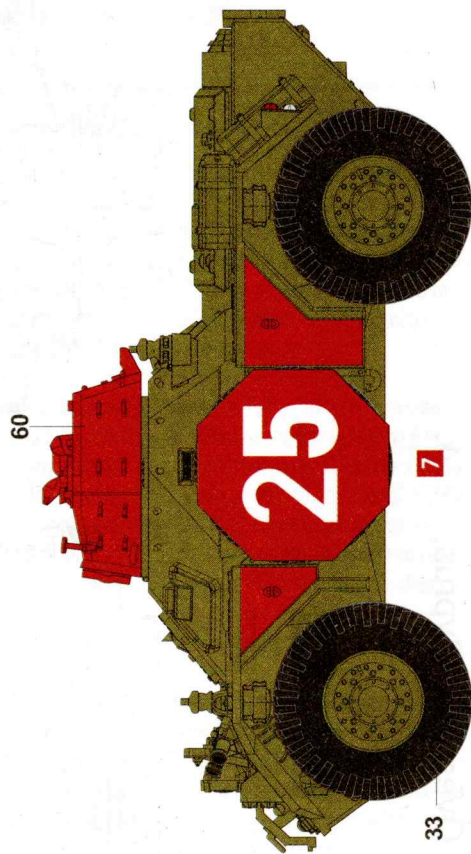
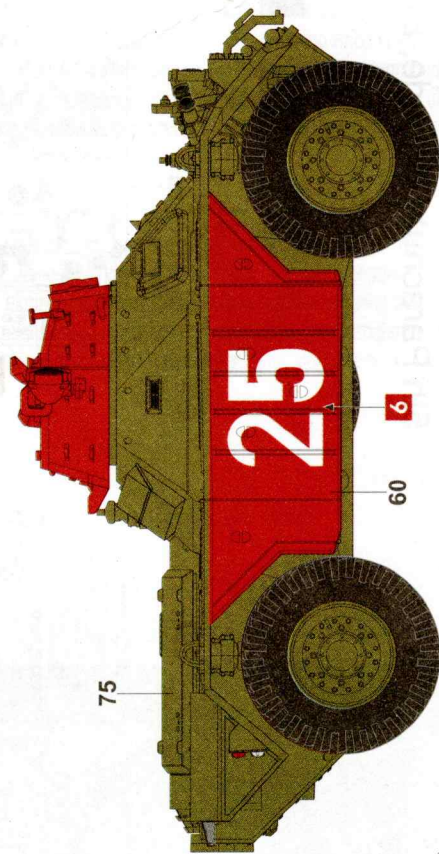
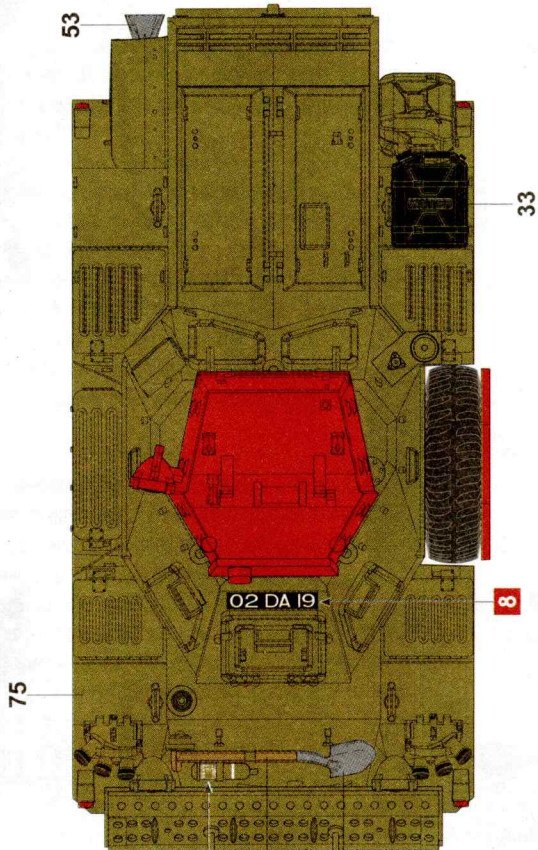
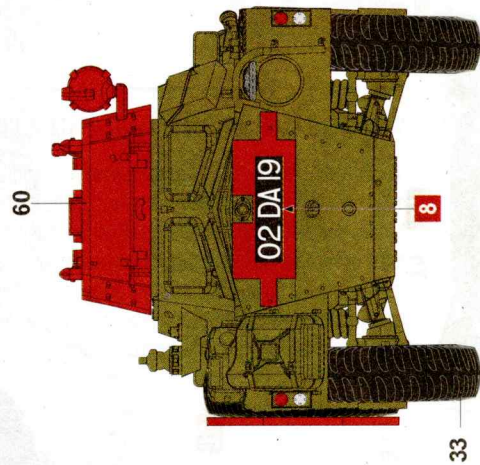
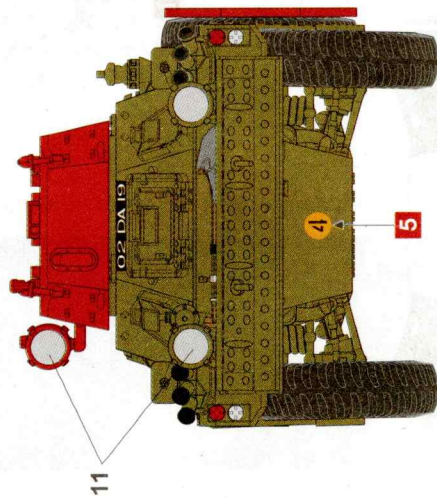

© Ferret Scout Car Mk.2
 5th Parachute Brigade, British Army Overseas, Cyprus, 1974.

- 11** Silver
- 29** Dark Earth
- 33** Matt Black
- 34** Matt White
- 53** Gun Metal
- 75** Matt Bronze Green

