

Sd.Kfz.164 Nashorn

JASON
Accessories designed & sculpted
by JASON STUDIO



ドイツ軍 Sd.Kfz.164 ナースホルンw/砲兵フィギュア 德国Sd.Kfz.164“犀牛”自行反坦克炮 附带炮兵组

● READY TO ASSEMBLE PRECISION MODEL KIT ● MODELING SKILLS HELPFUL IF UNDER 14 YEARS OF AGE ● MODEL MAY VARY FROM IMAGE ON BOX ● CEMENT AND PAINT NOT INCLUDED

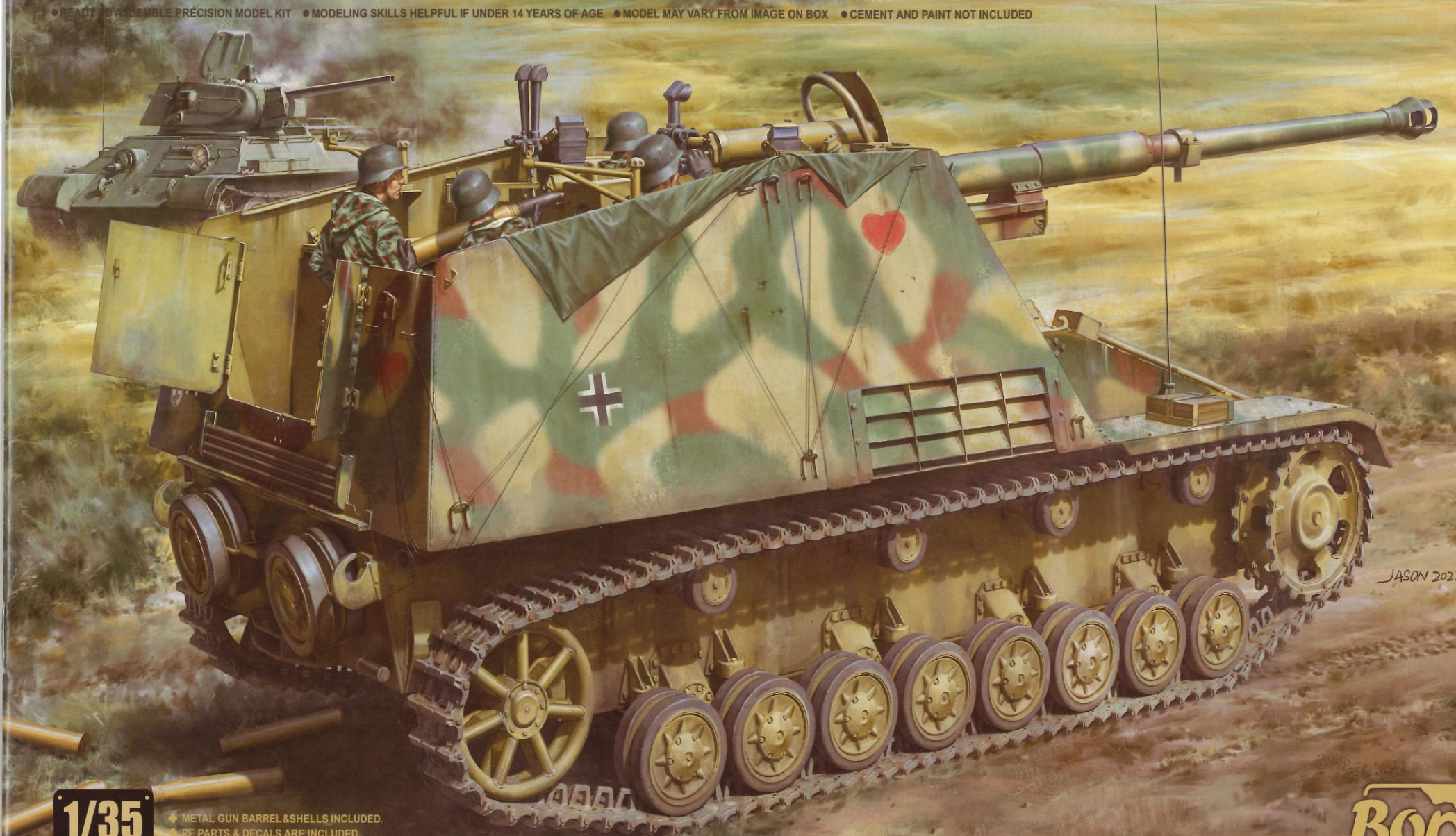

JASON 2022

1/35
SCALE
BT-024

- ◆ METAL GUN BARREL & SHELLS INCLUDED.
- ◆ RE PARTS & DECALS ARE INCLUDED.
- ◆ 4 CREW FIGURES INCLUDED.
- ◆ YOU CAN CHOOSE TO MAKE 2 VERSIONS.
- ◆ LINK & LENGTH STYLE TRACKS INCLUDED. EASY TO ASSEMBLE.
- ◆ INCLUDES BUCKETS, T-34 TRACKS & PACKAGES AS MOUNTINGS.

Border

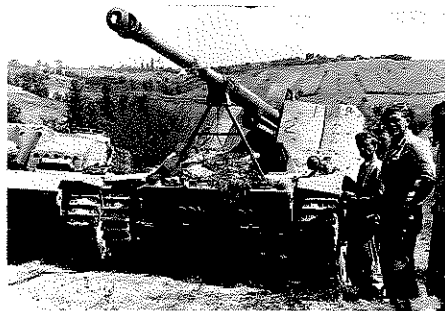

History | 历史介绍

In February 1942, Alkett fitted the Pak 43 anti-tank gun on a Geschutzwagen III/IV chassis, designed as the "Hornisse" (Hornet), and later in 1942, this hull was also used for the Hummel self-propelled howitzer (Sd.Kfz.165). The engine was moved to the center and the hull was extended to accommodate the long-barreled 88mm anti-tank gun, while still balancing the weight distribution of the vehicle. Due to the huge weight of the gun and the hull's load capacity, the crew was only protected by light armor.

In October 1942, the full model was presented to Hitler himself and was approved, and he also wanted production to start in May 1943. In early 1944, the arrangement of the front armor plate of the cab was changed in production, and the gun was changed to PaK 43, so that there were two different versions of the vehicle, and on February 24 (or 27), 1944, Hitler ordered the second model to be named "Nashorn" (Rhinoceros). "There was no difference between the Hornisse and the Nashorn except for the arrangement of the front armor plate of the cab and the gun type, both of which were inconsequential. Despite the lack of armor protection, both provided much needed mobility for the powerful 88mm anti-tank gun. The limited space in the battle chamber limited the ammunition capacity, which was usually between 24-40 rounds. "The Hornisse and Nashorn's open top combat chambers relied only on canvas for shelter from the elements and lacked a hull machine gun, usually an MG34 or MG42, to provide close combat defense. From February 1943 to March 1945, the production of Hornisse and Nashorn self-propelled anti-tank guns designed by Alkett and built by Deutsche Eisenwerke was very low, 20 and 47 respectively. The production of Hornisse and Nashorn designed by Alkett and built by Deutsche Eisenwerke was very low, 20 and 474 respectively.

Both types of self-propelled anti-tank guns were equipped with heavy tank destroyer battalions, and the first combat was with the 655th heavy tank destroyer battalion at the Battle of Kursk. They were so successful that a total of six such heavy tank destroyer battalions were later equipped and saw action on all fronts (e.g. the 525th Heavy Tank Destroyer Battalion fought on the Italian front in 1944). They were eventually replaced by more powerful and better protected self-propelled anti-tank guns such as the No. 4 Tank Destroyer and the Cheetah Tank Destroyer, but their war history lasted until the end of the war.

1942年2月，埃克特(Alkett)公司在Geschutzwagen III/IV的底盘上装备了Pak43反坦克炮，设计定名为“Hornisse”(大黄蜂)。1942年晚些时候，这种车体还被用于野蜂(Hummel)自行榴弹炮(编号Sd.Kfz.165)。引擎被移到中间，车体被延长以容纳长身管的88毫米反坦克炮，同时还可以平衡整车的重量分布。由于火炮的巨大重量和车体承载能力的限制，乘员组只能受到轻型装甲的保护。

1942年10月，整车模型向希特勒本人做了展示，得到了批准，他还希望生产能于1943年5月开始。1944年早期，驾驶室前装甲板的布置在生产中有了变动，火炮也变为PaK43，这样该车就有了两种不同的型号。1944年2月24日(一说27日)，希特勒下令将第二种型号命名为“Nashorn”(犀牛)。“大黄蜂”和“犀牛”除了驾驶室前装甲板的布置和火炮型号外没有任何区别，而这两点变动都是无关紧要的。尽管缺少装甲防护，二者都为威力强大的88毫米反坦克炮提供了急需的机动性。战斗室的有限空间使载弹量受到限制，通常在24-40发之间。“大黄蜂”和“犀牛”顶部敞开的战斗室仅依靠帆布来遮蔽风雨，而且缺乏一挺车体机枪，通常一挺MG34或MG42机枪会配备在车体内以提供近战防御。从1943年2月到1945年3月，由埃克特(Alkett)公司设计、德国埃森工厂(Deutsche Eisenwerke)制造的“大黄蜂”和“犀牛”自行反坦克炮产量很低，分别为20辆和474辆。

这两种型号的自行反坦克炮都装备了重型坦克歼击炮营，第一次作战是跟随第655重型坦克歼击炮营参加库尔斯克会战。它们表现得很成功，所以以后一共装备了6个这样的重型坦克歼击炮营，出没在各条战线(例如1944年第525重型坦克歼击炮营在意大利战线作战)。最后它们逐渐被威力更大、防护更好的自行反坦克炮如四号坦克歼击车和猎豹坦克歼击车所取代，但它们的战史一直持续到战争结束。

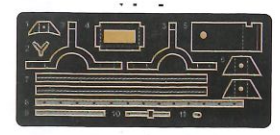
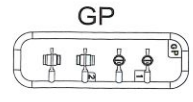
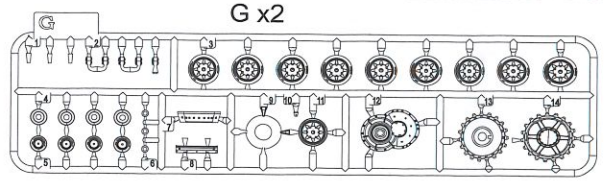
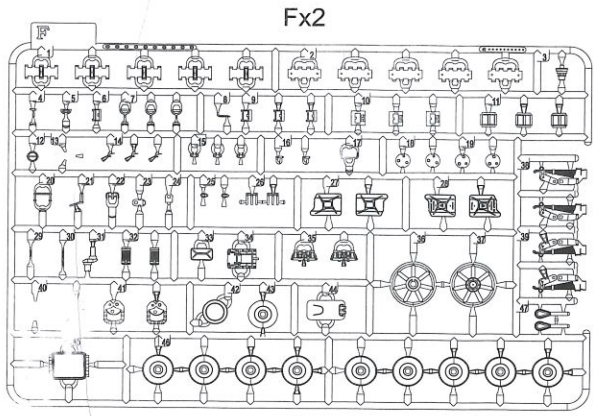
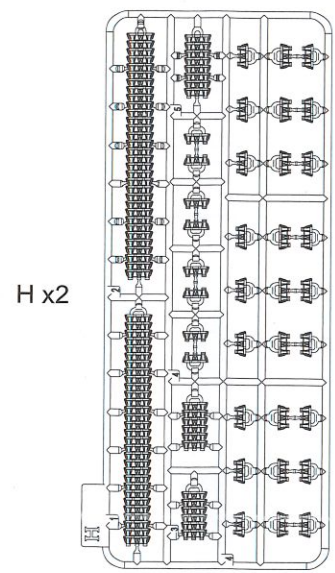
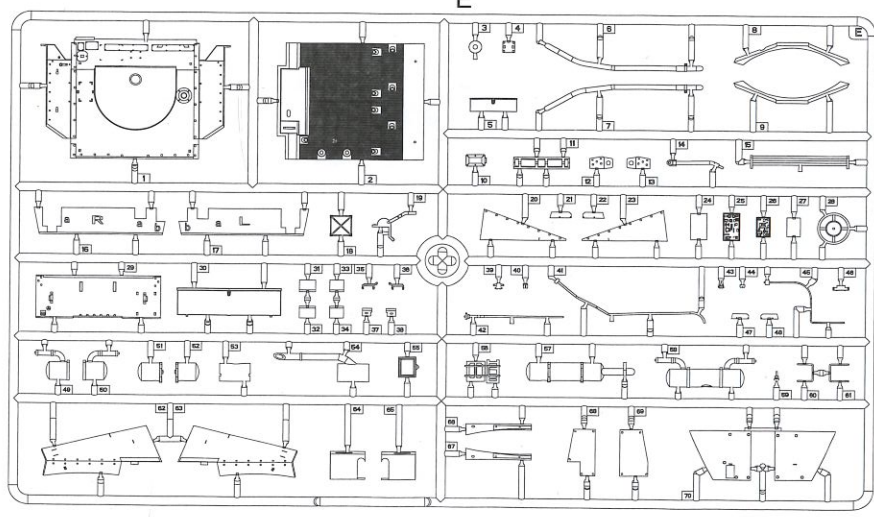
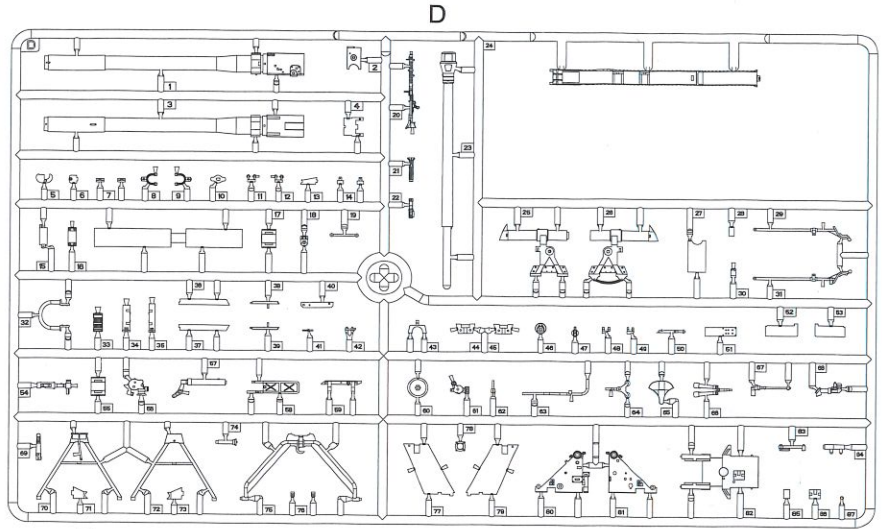
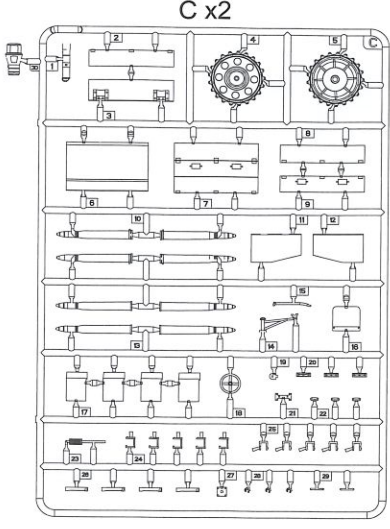
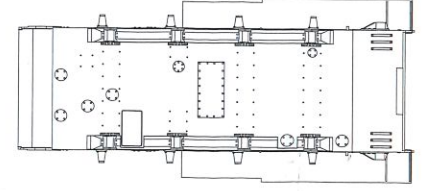
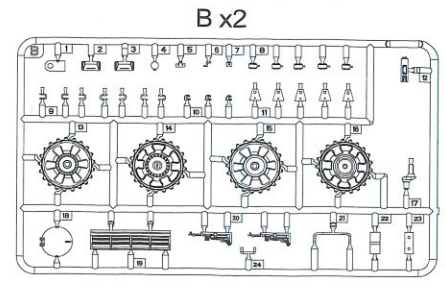
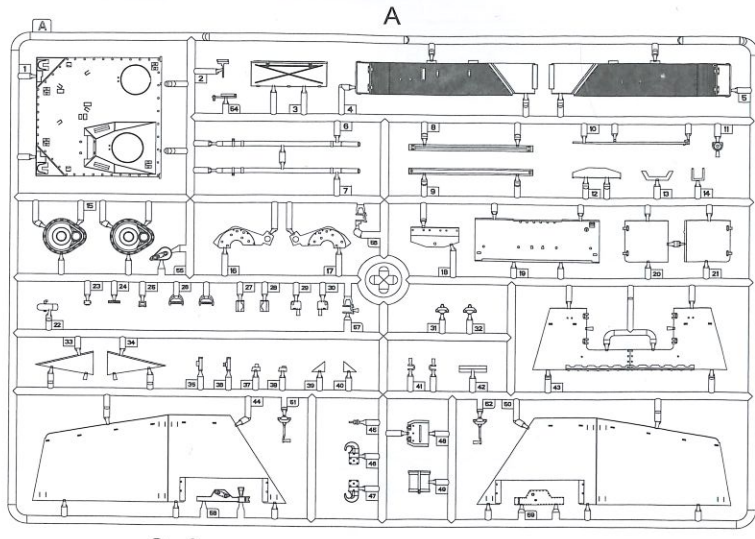

1

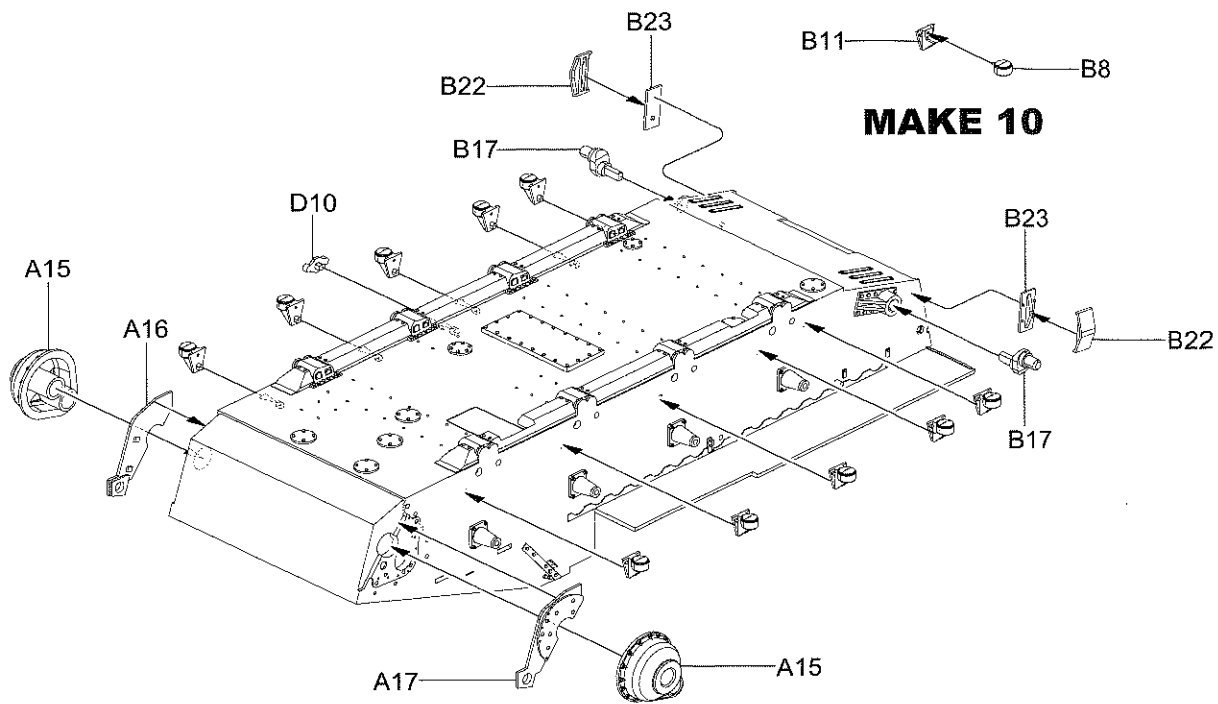

MAKE 10

2

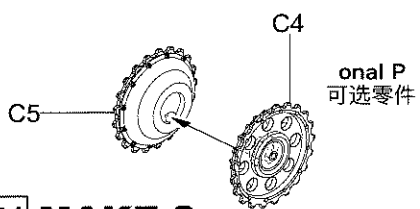

A1 MAKE 2

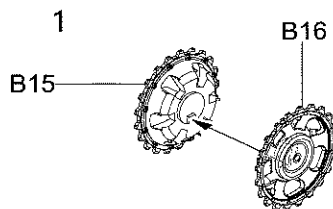

A2 MAKE 2

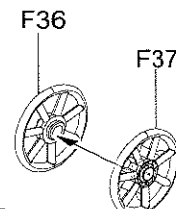

B MAKE 2

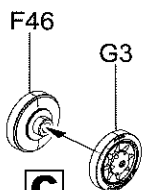

MAKE 16

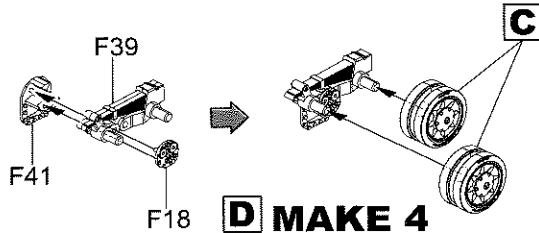

D MAKE 4

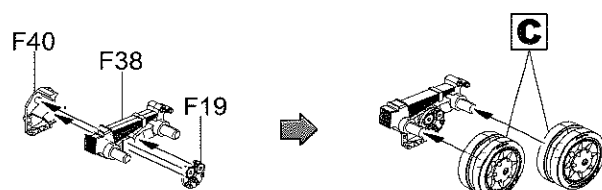

E MAKE 4

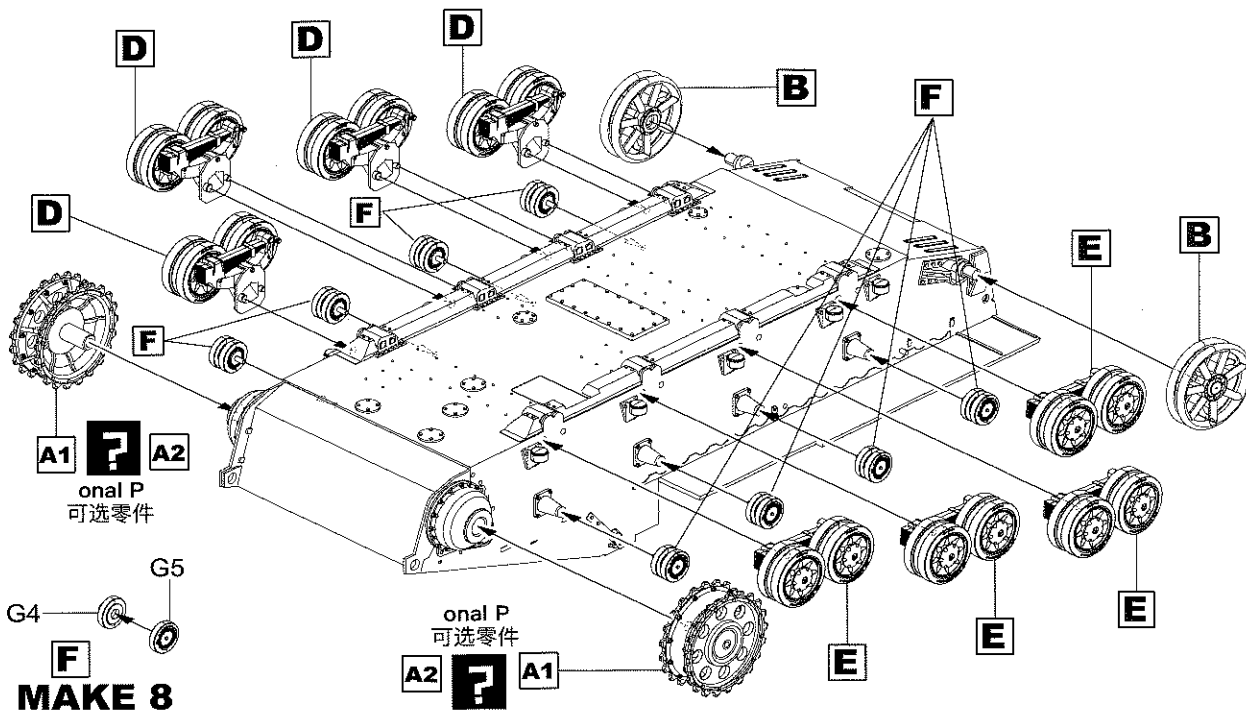

MAKE 8

3

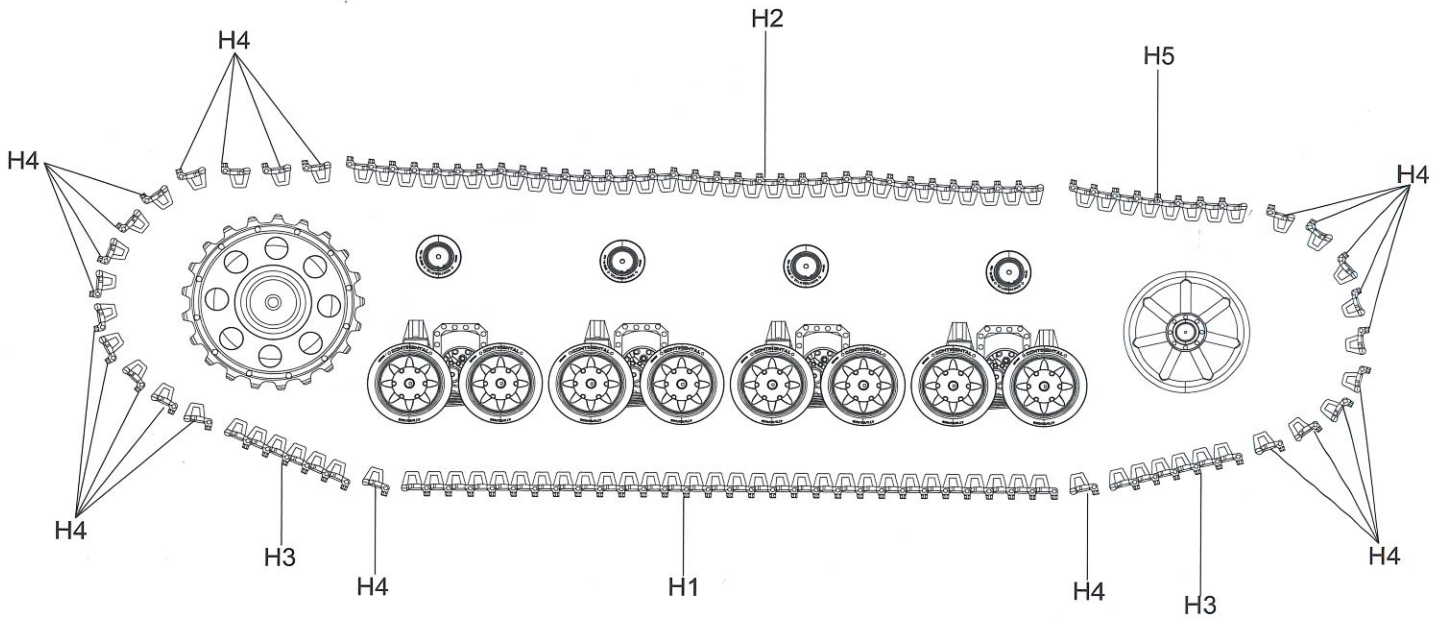
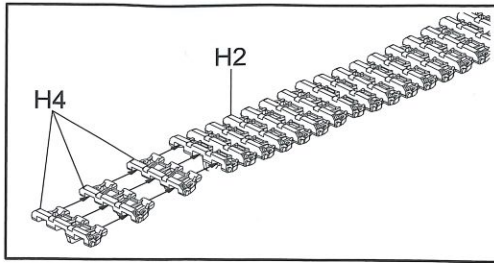

4

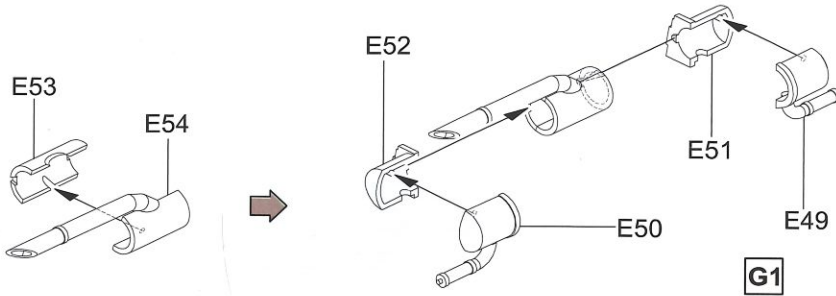

?
onal P
可选零件

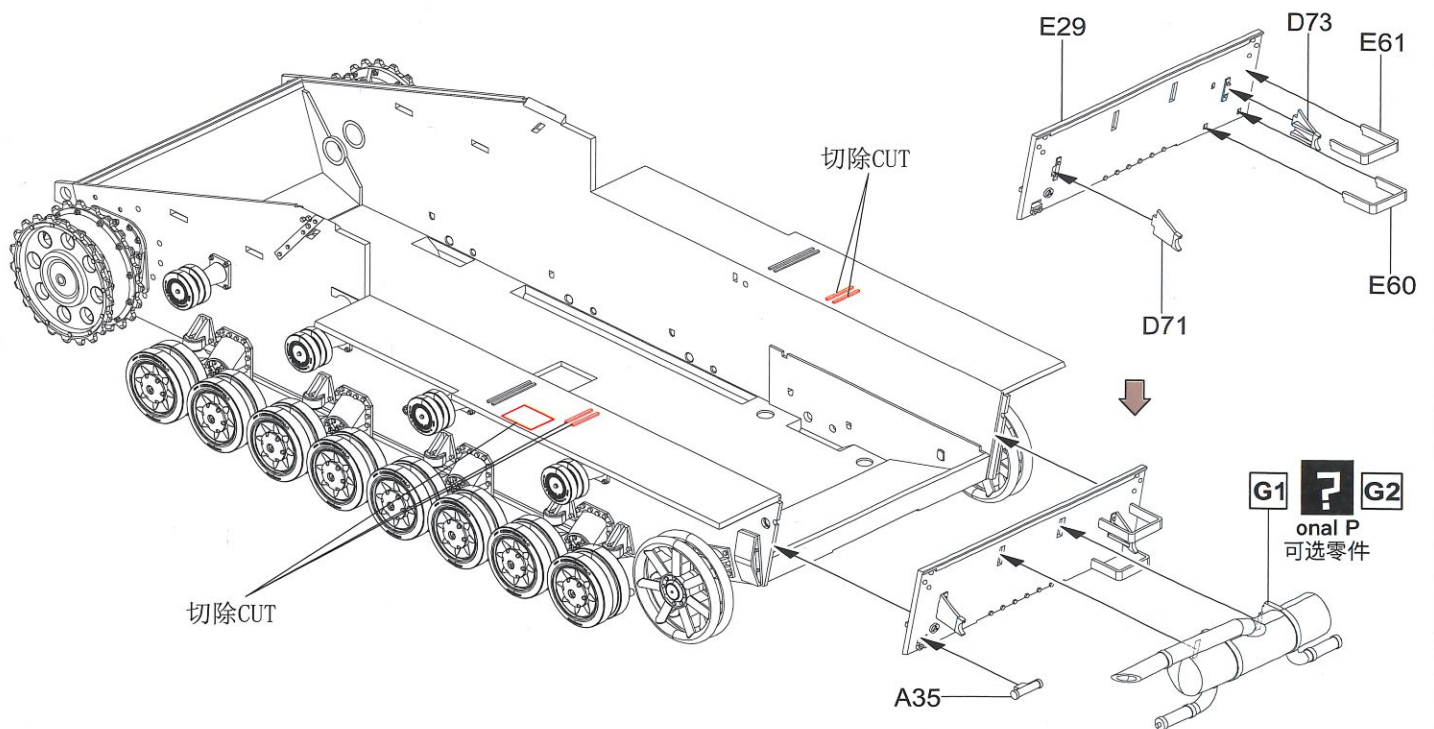
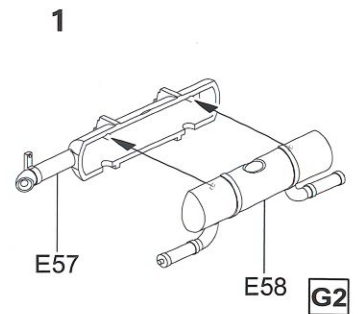

5

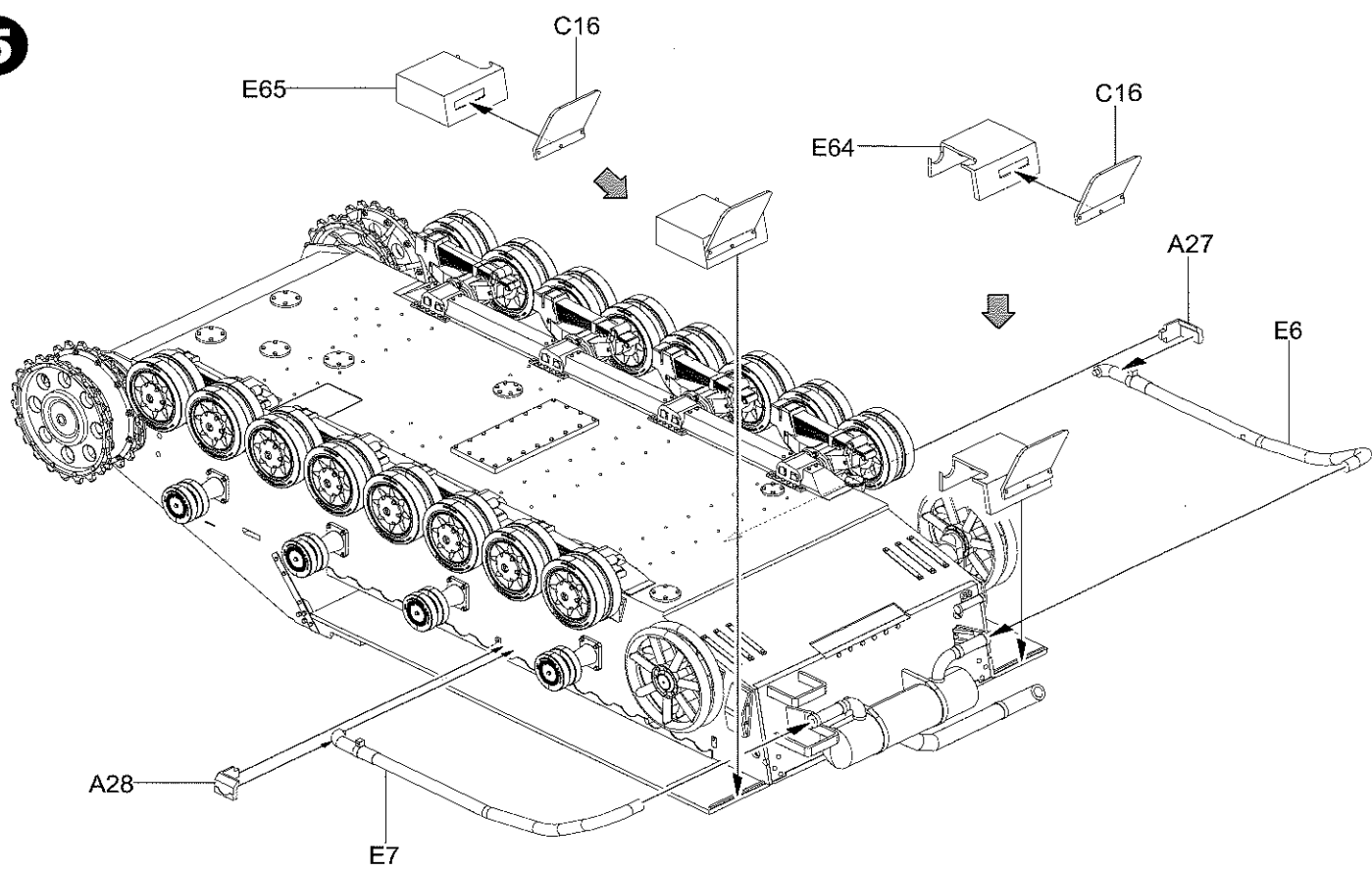

6

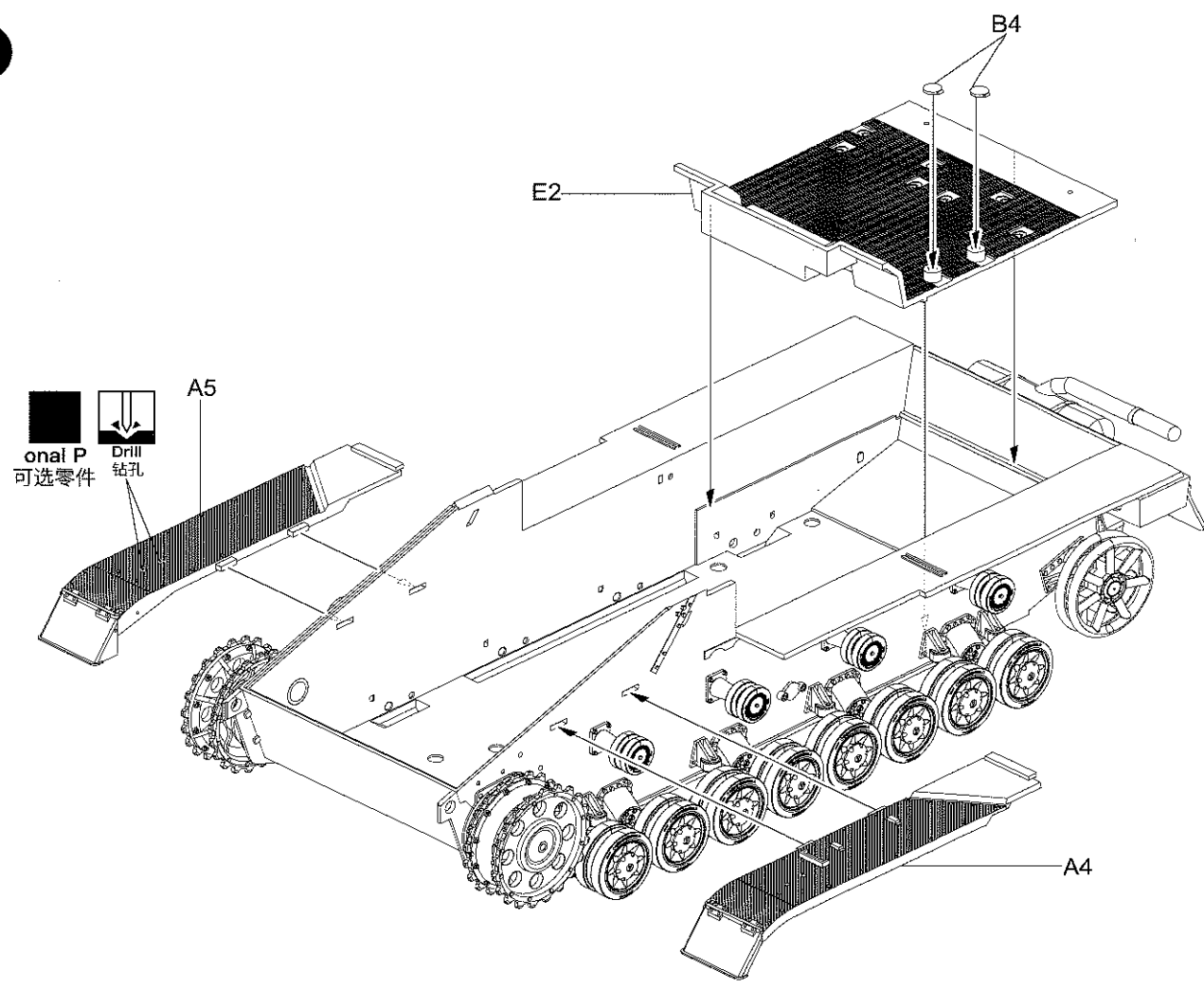

7

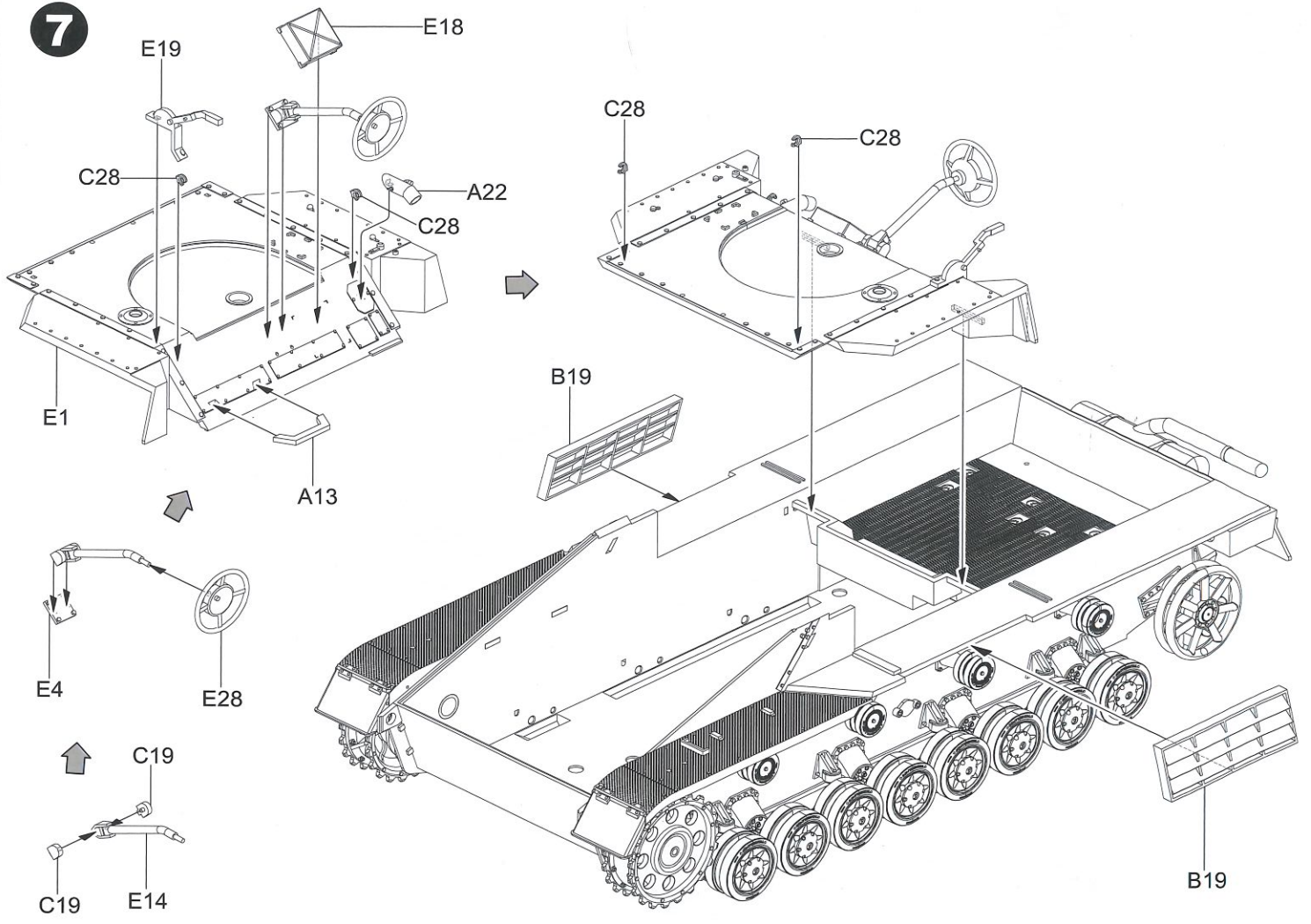

8

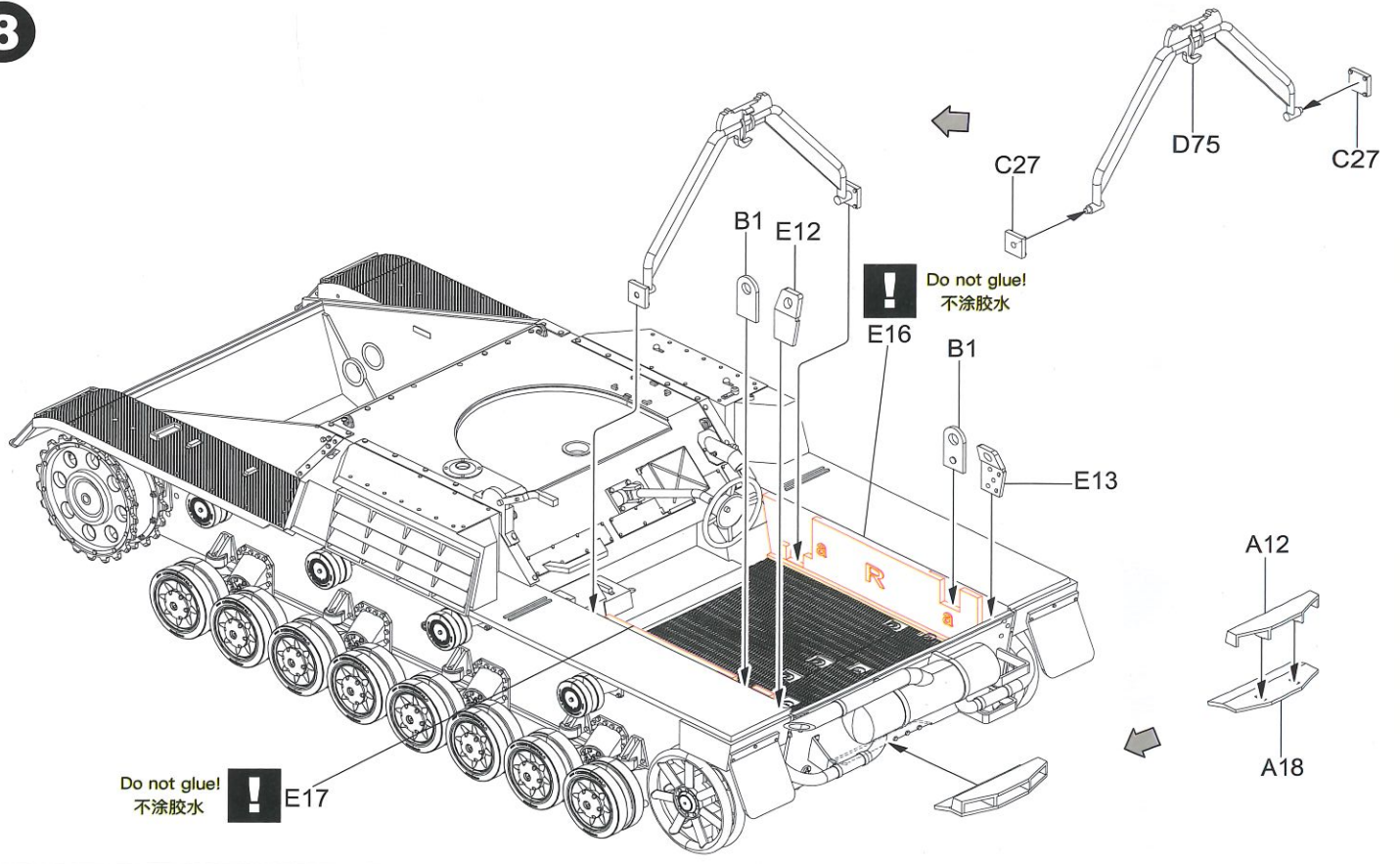

9

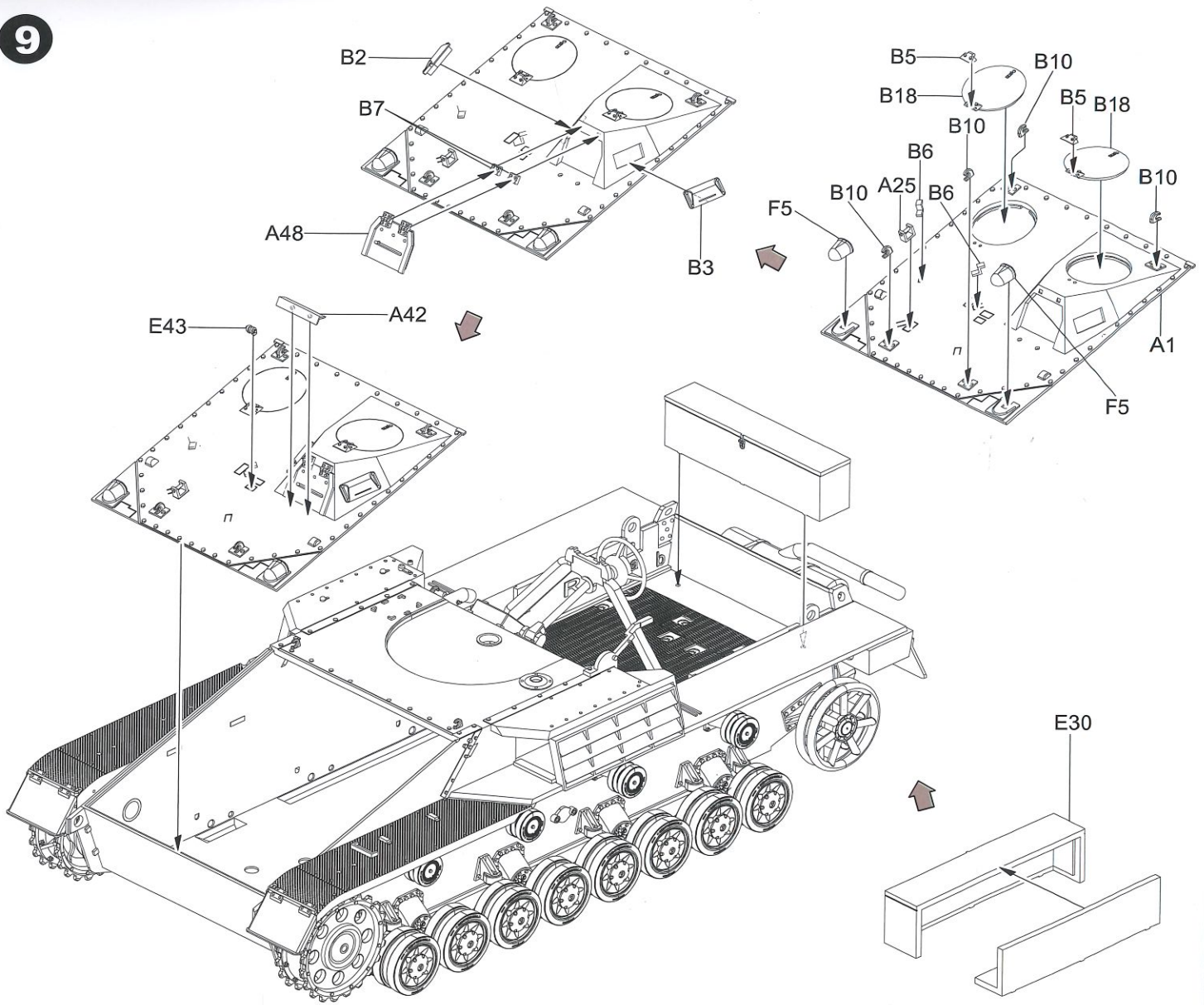

10

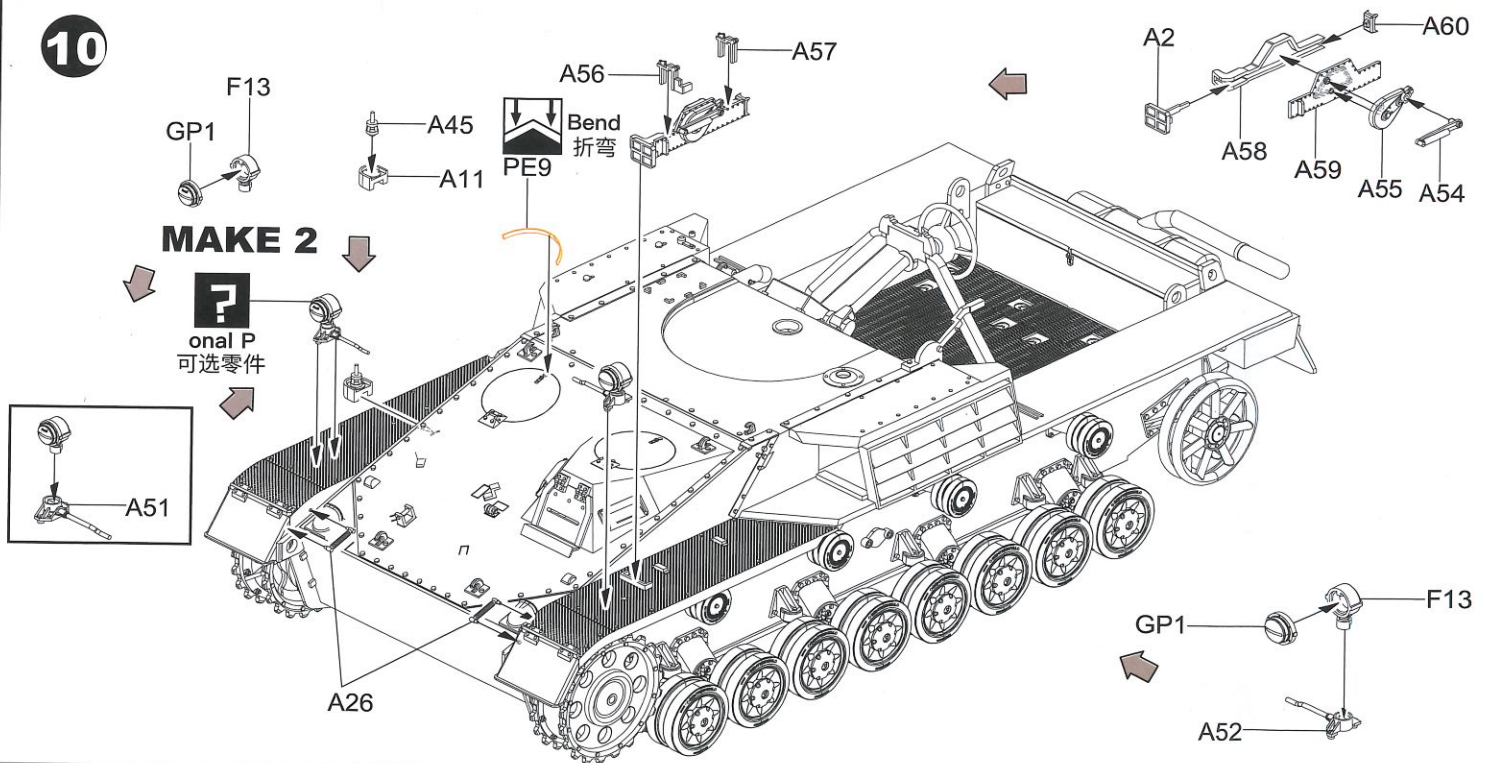

11

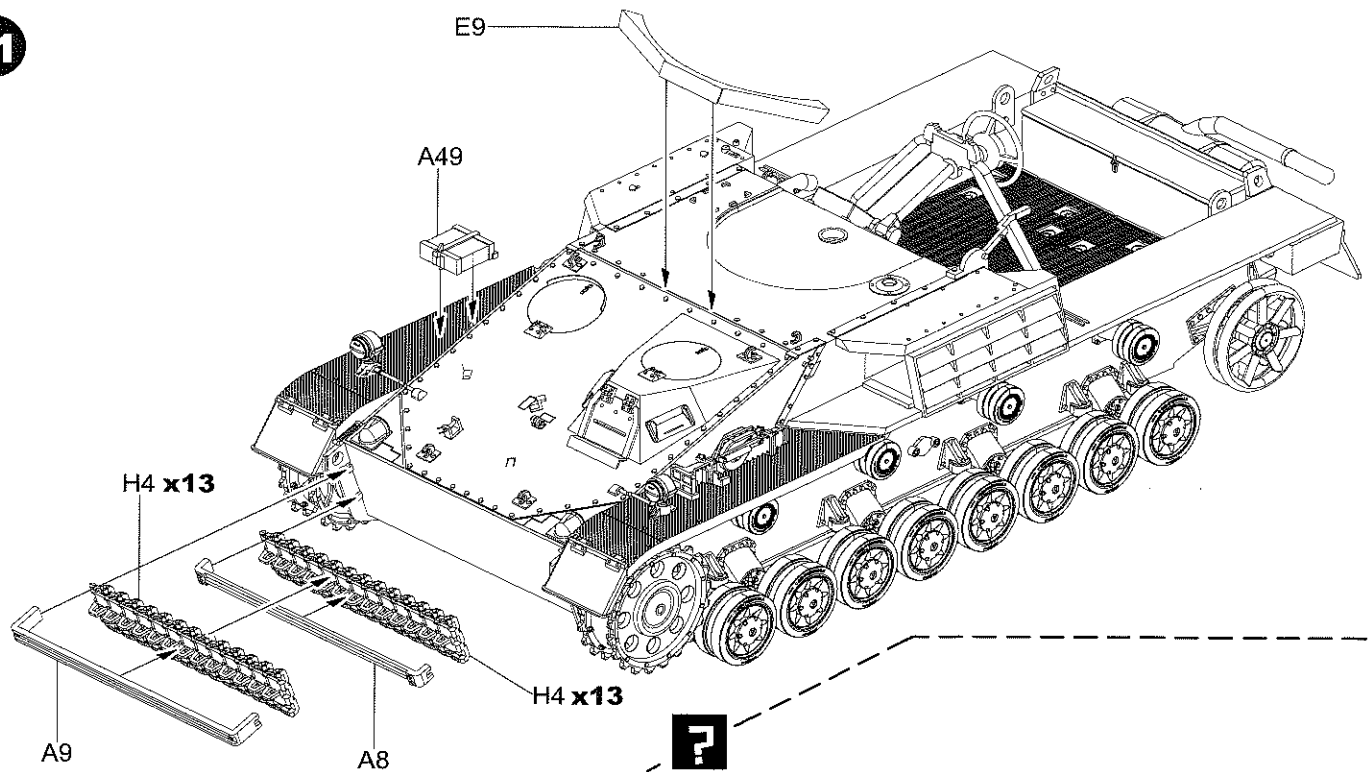

Optional P
可选零件

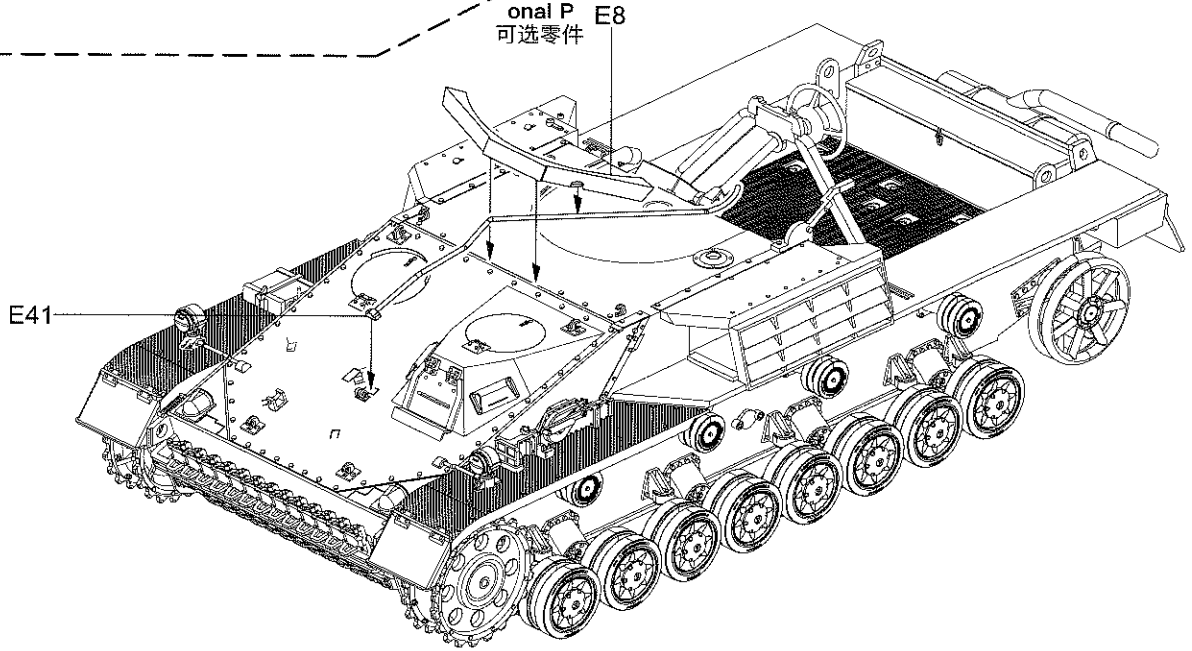

The steps for using metal cannons are on the next page
下一页有使用金属炮管的步骤

12

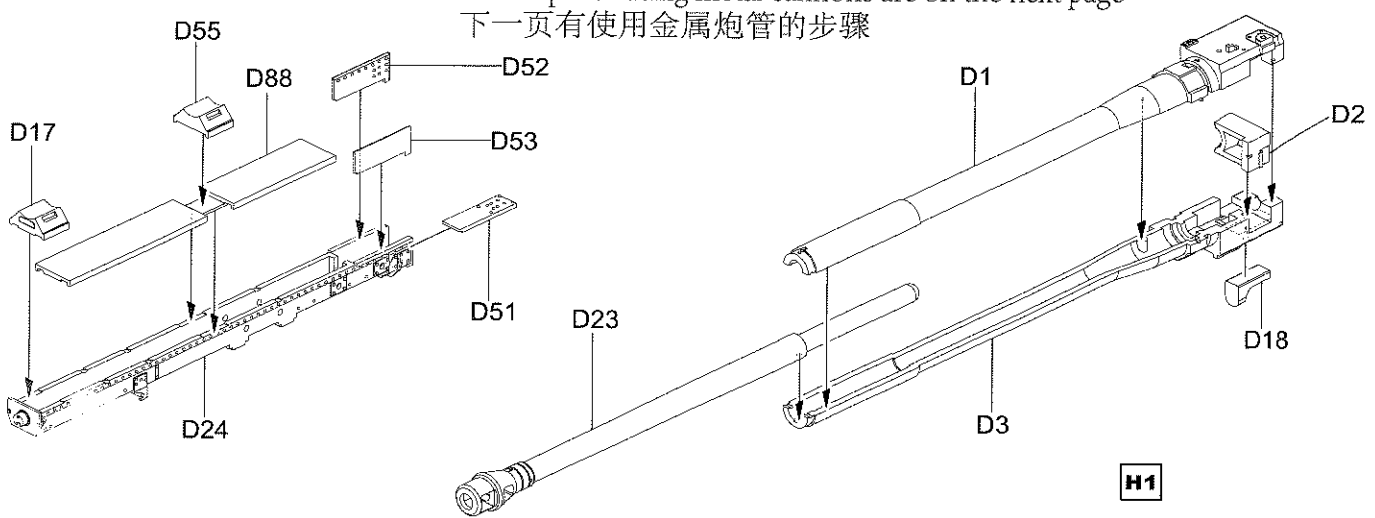

13

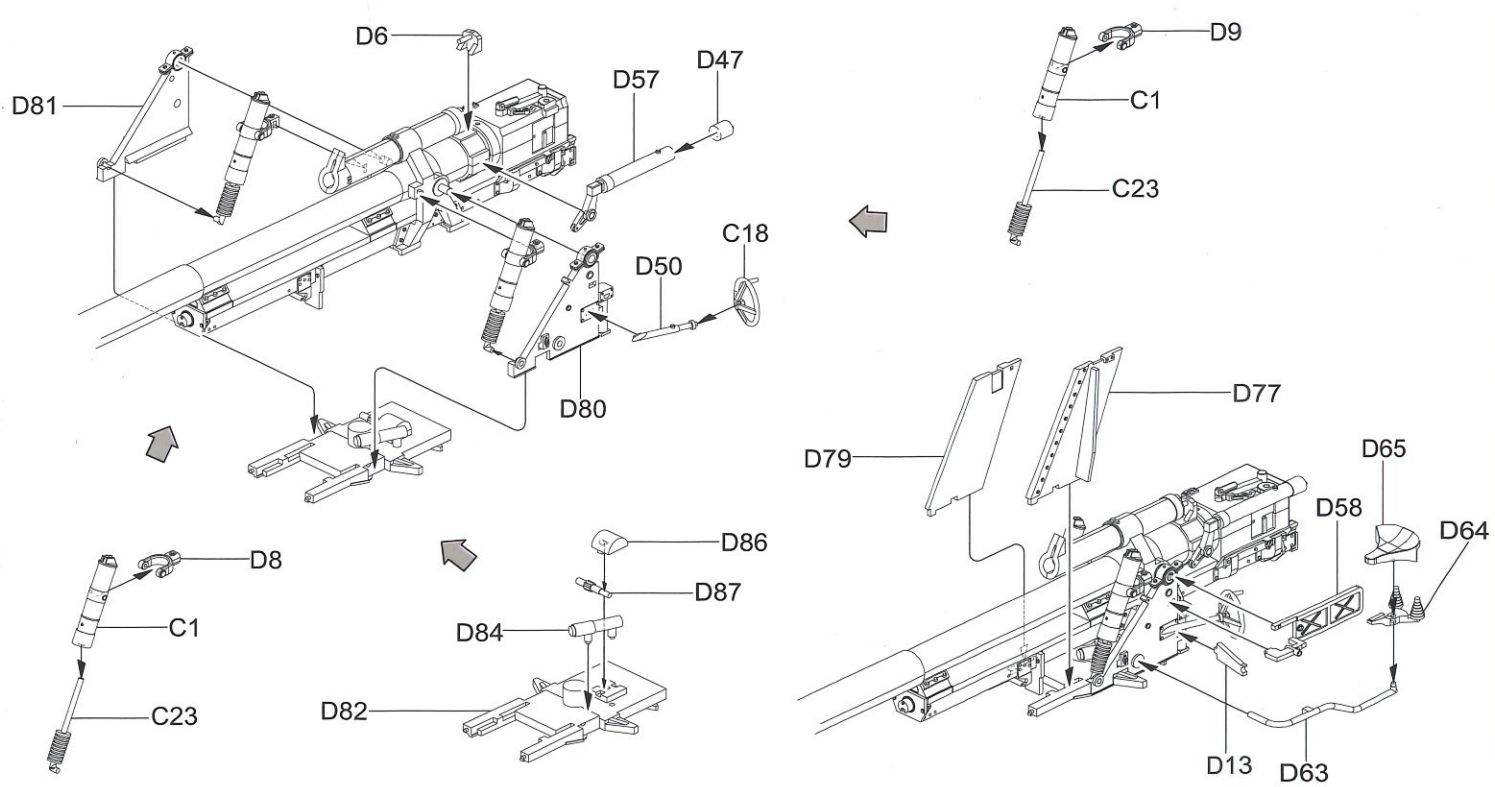
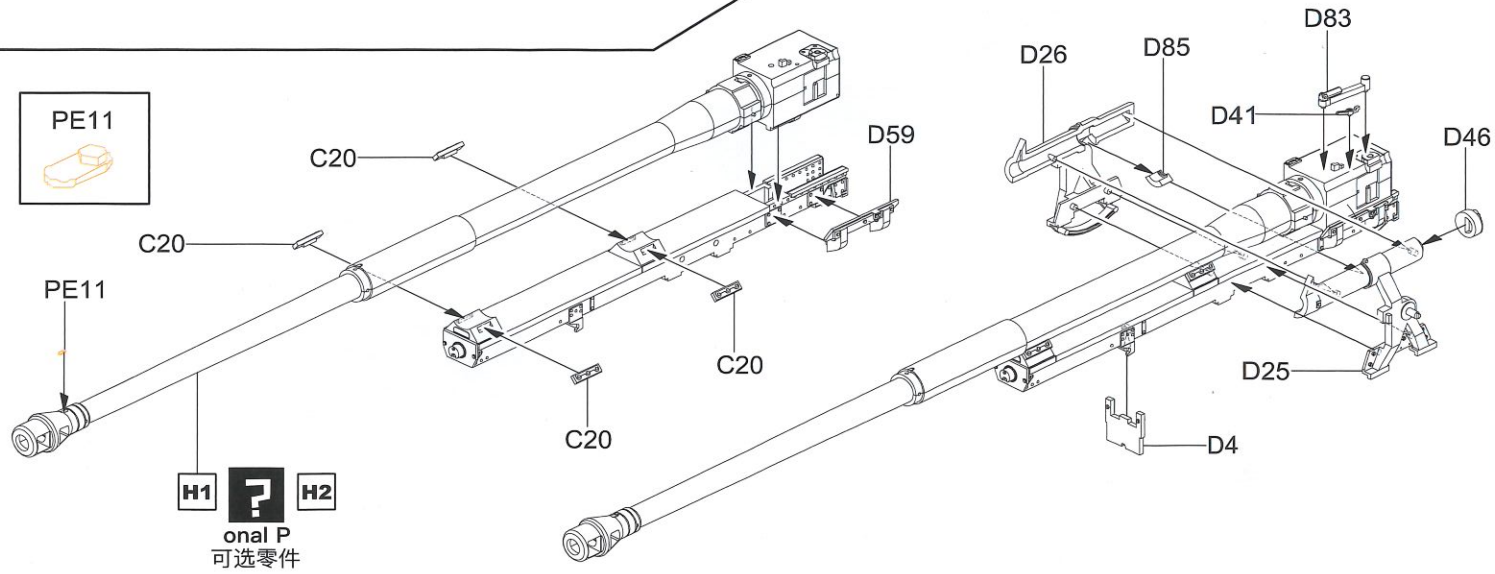
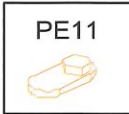
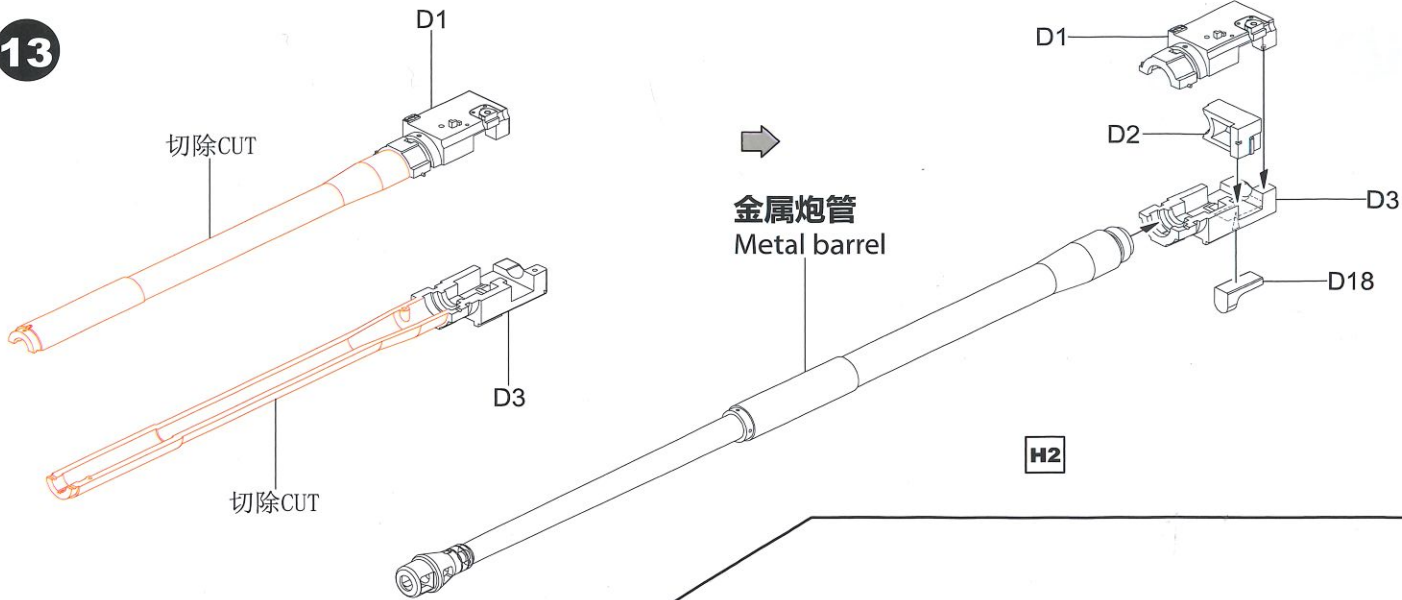

14

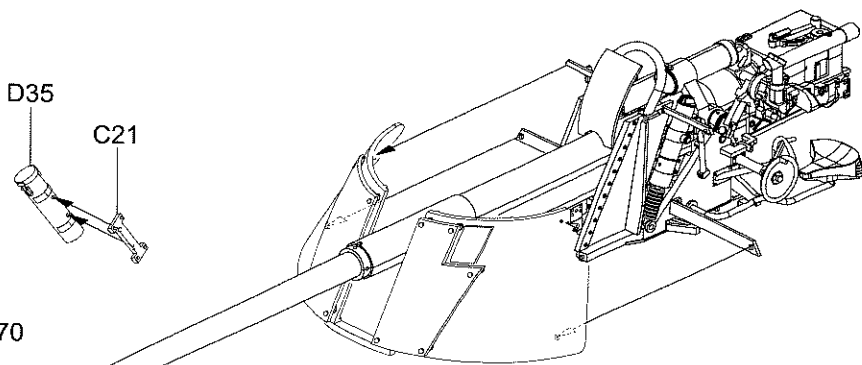
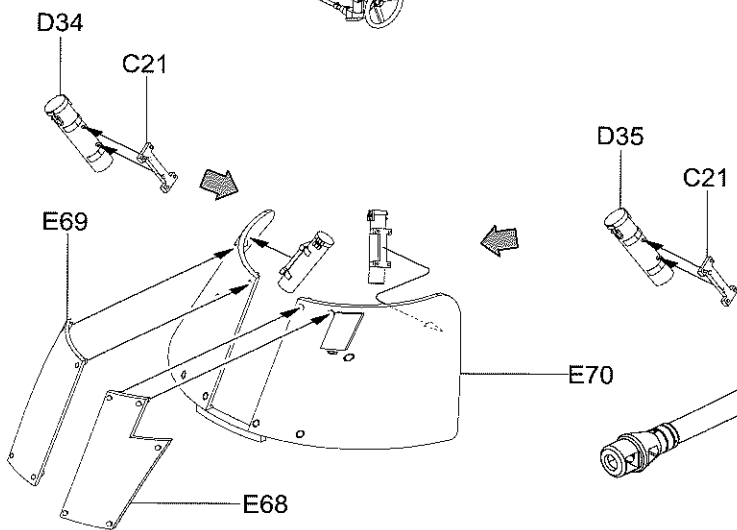
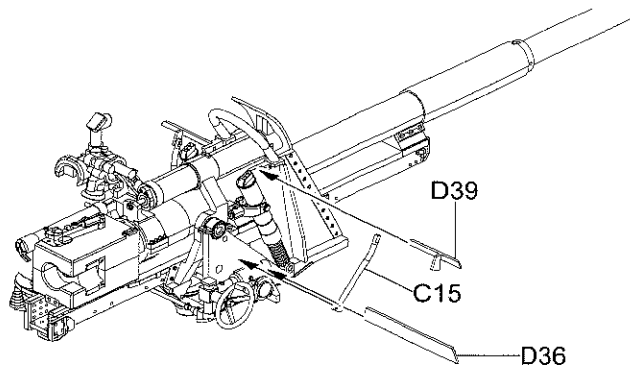
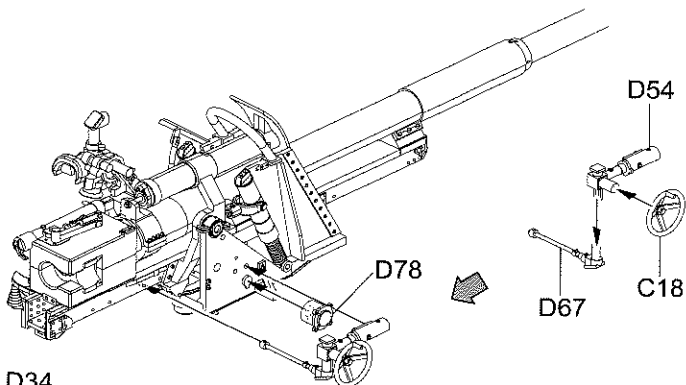
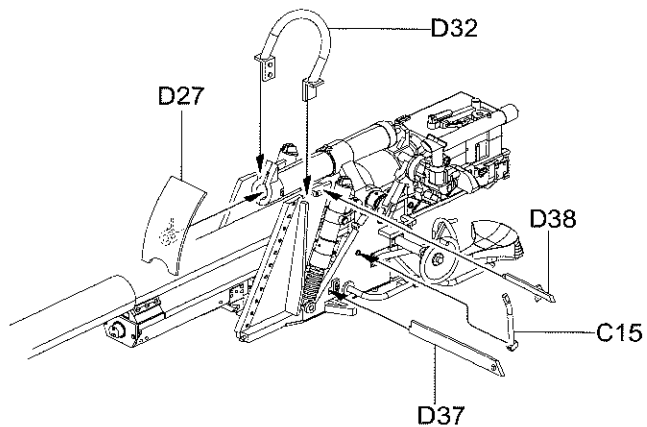
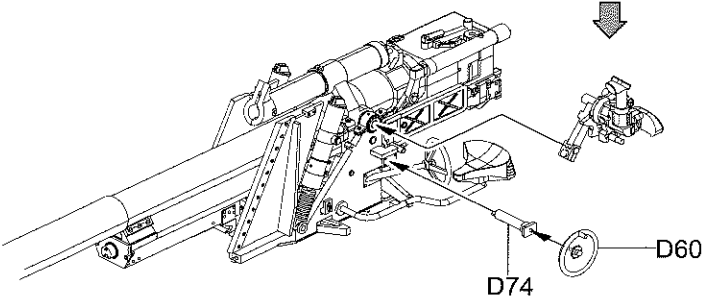
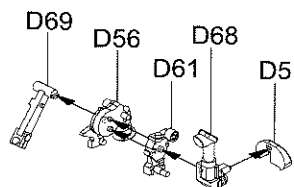

J

15

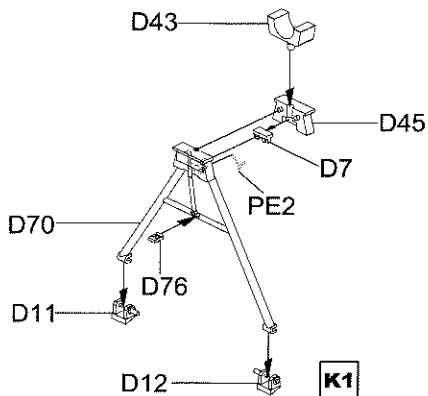

K1

?
 onal P
 可选零件

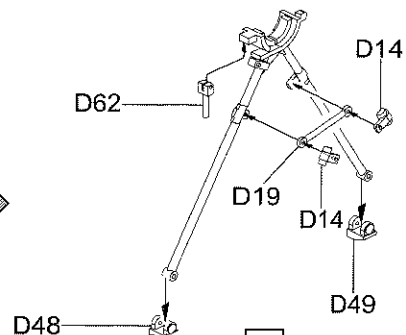
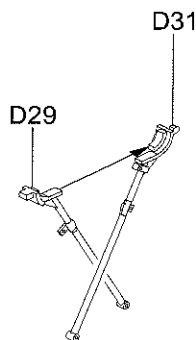

K2

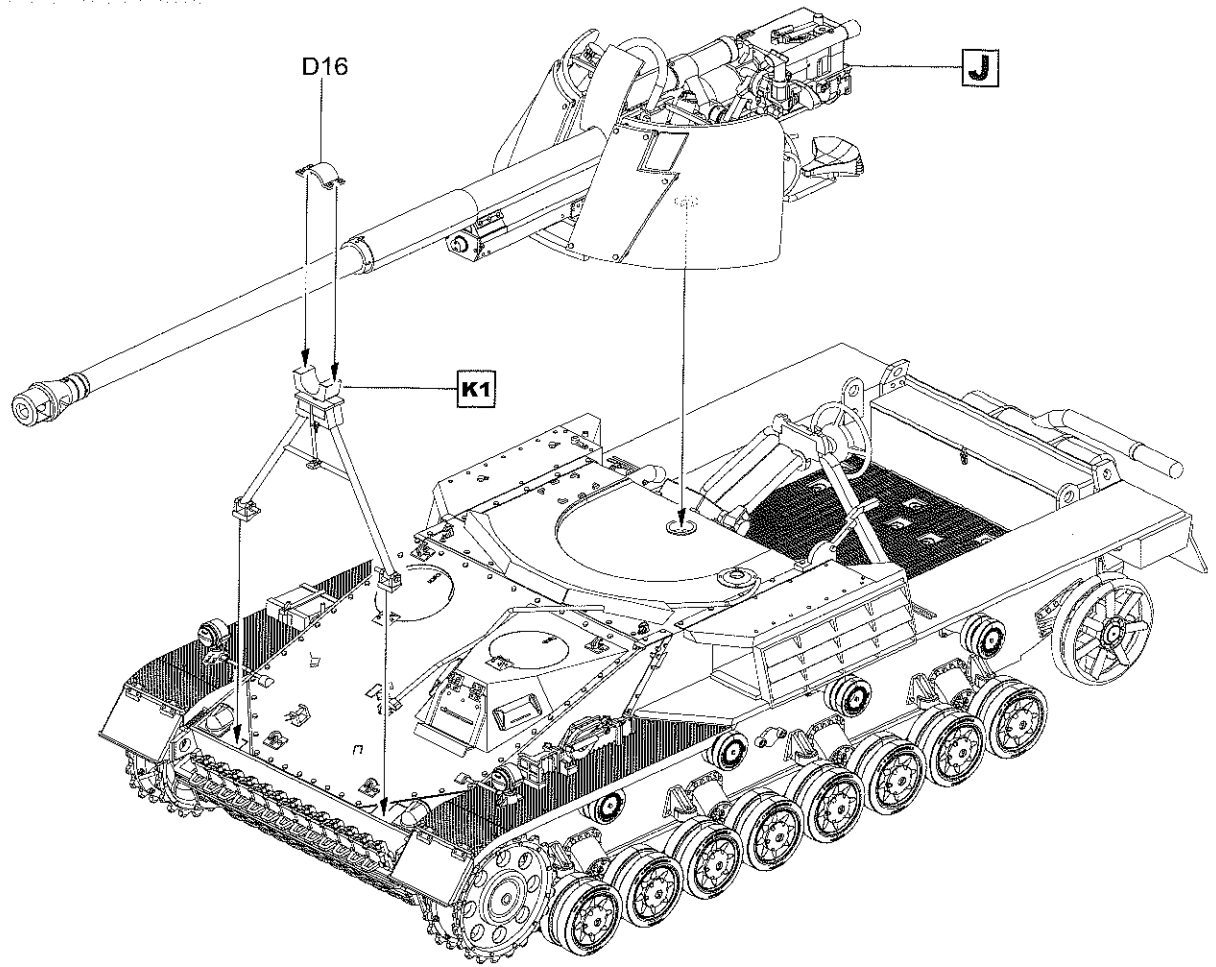

Optional P
可选零件

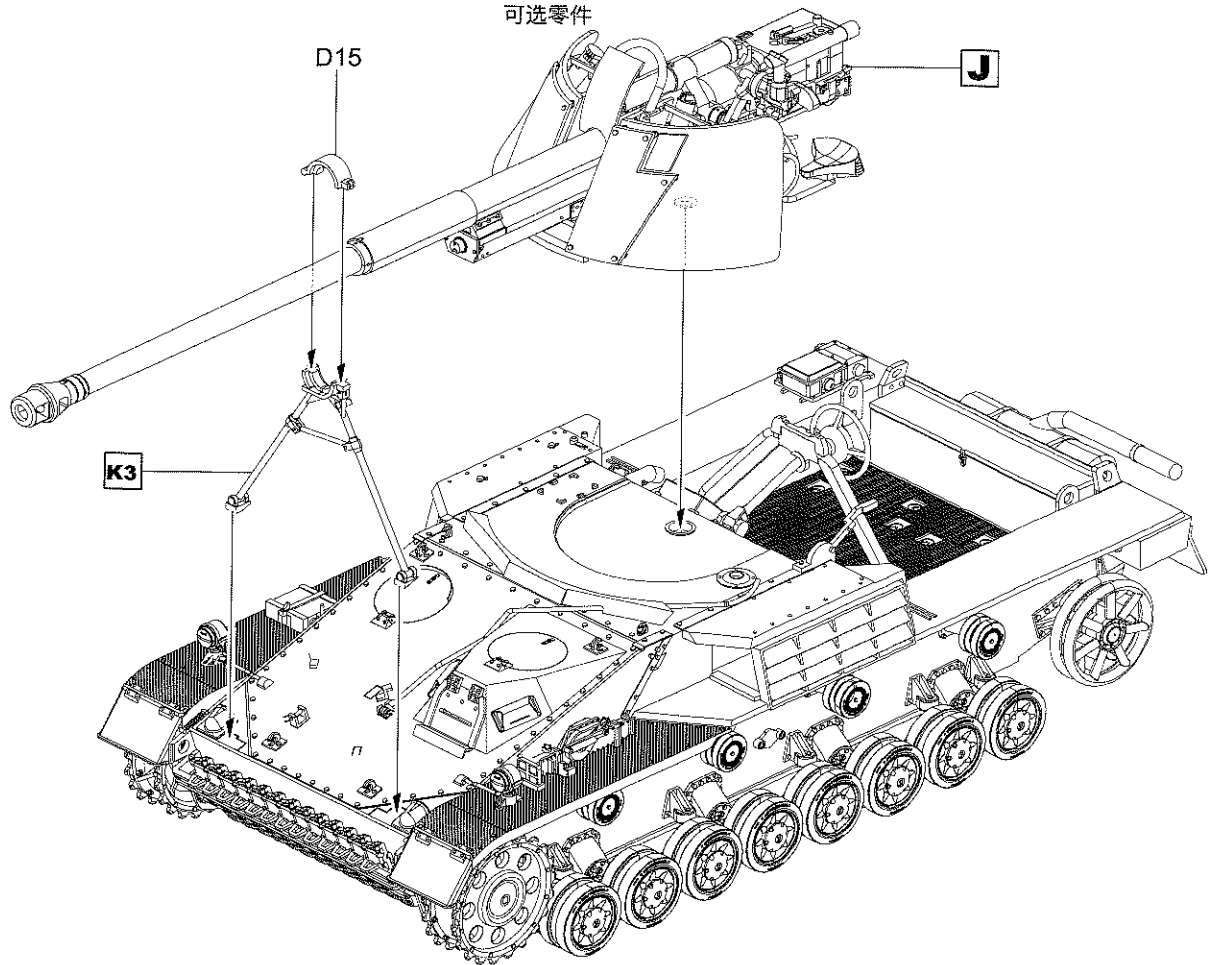

17

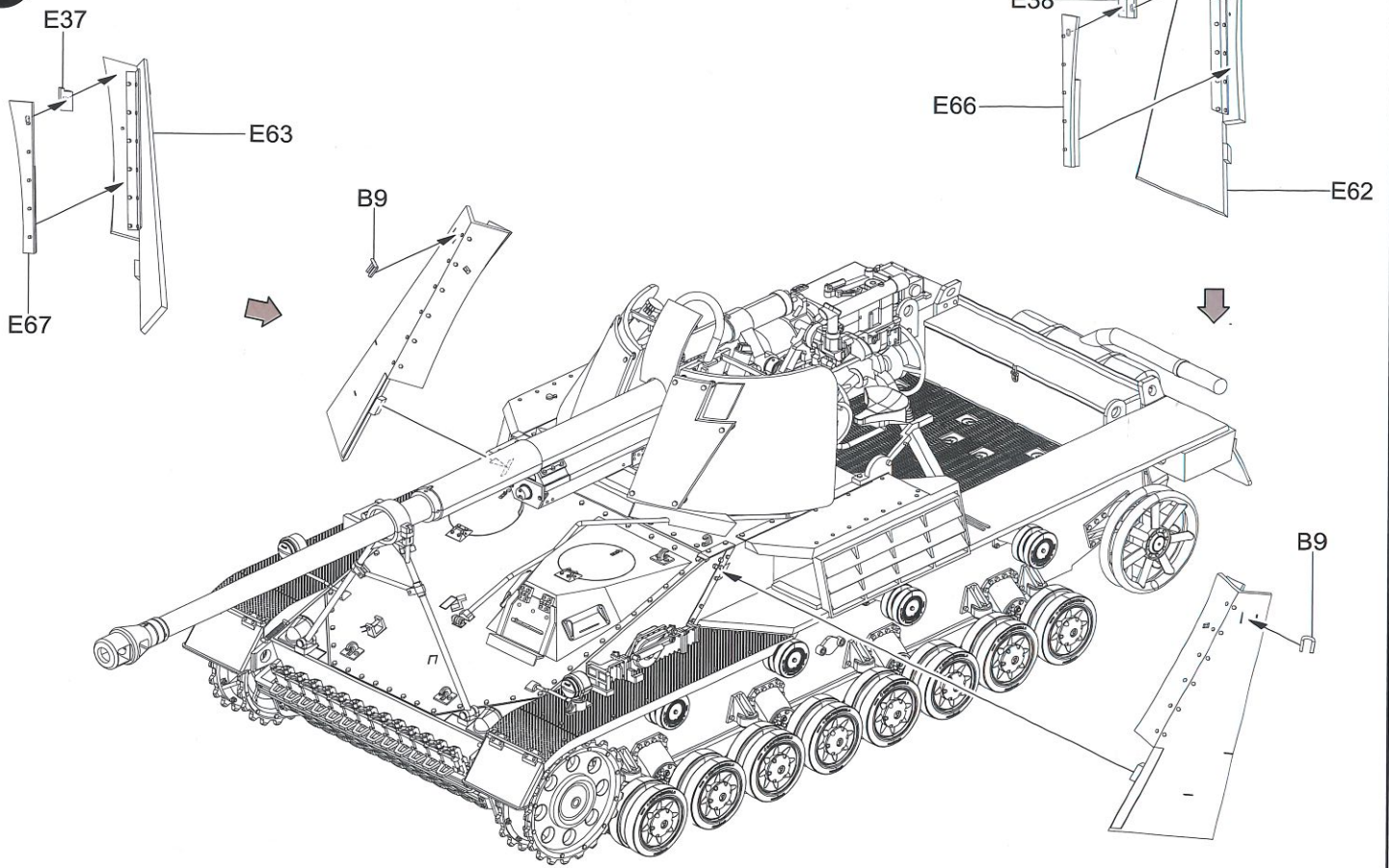

18

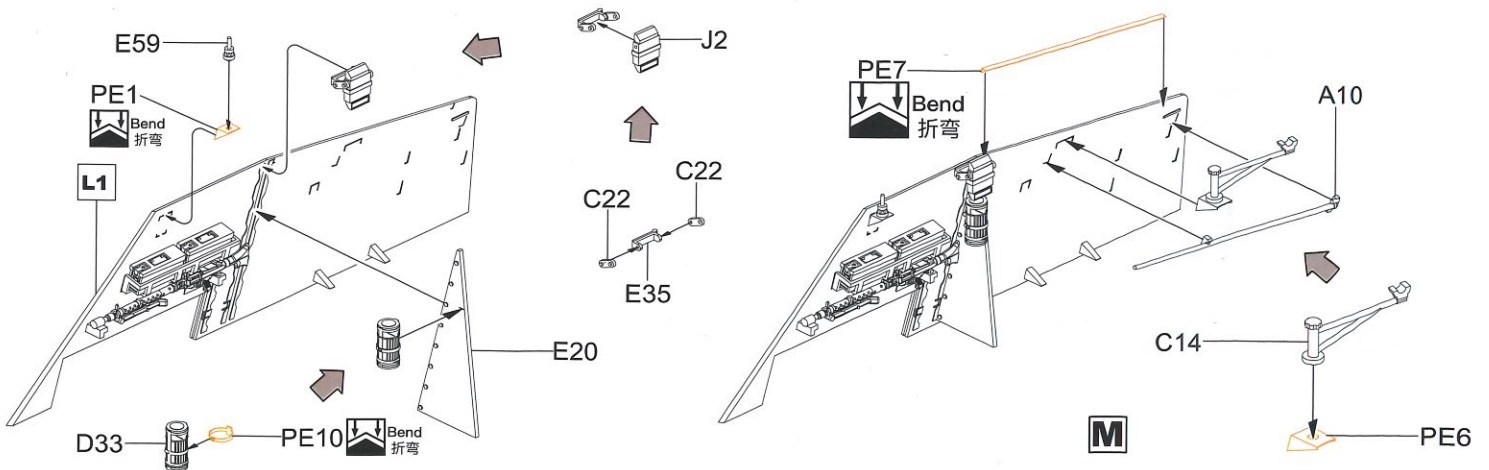
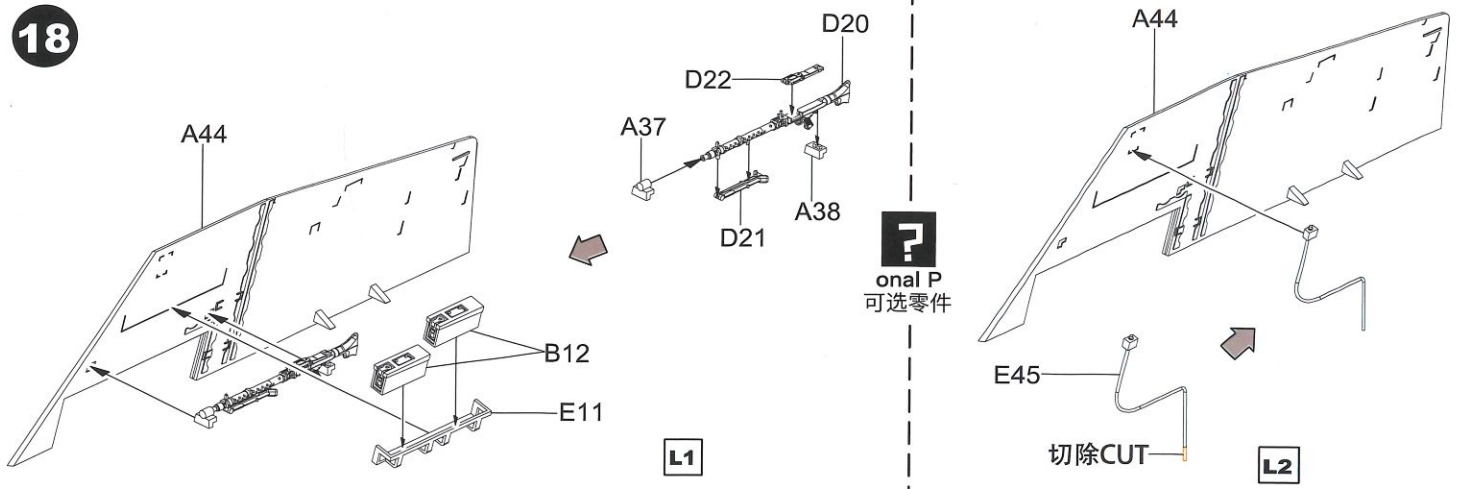

19

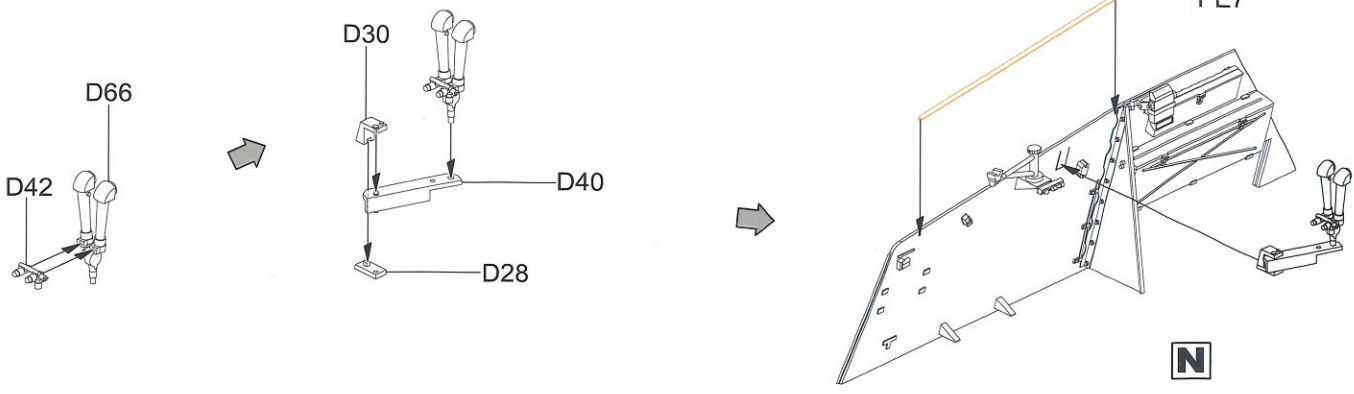
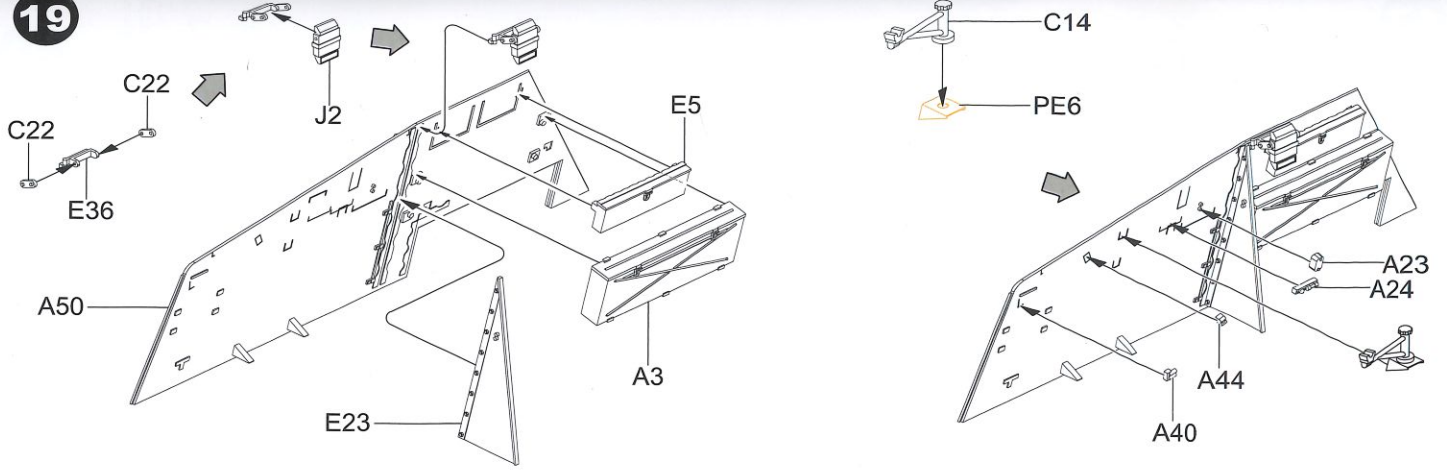

20

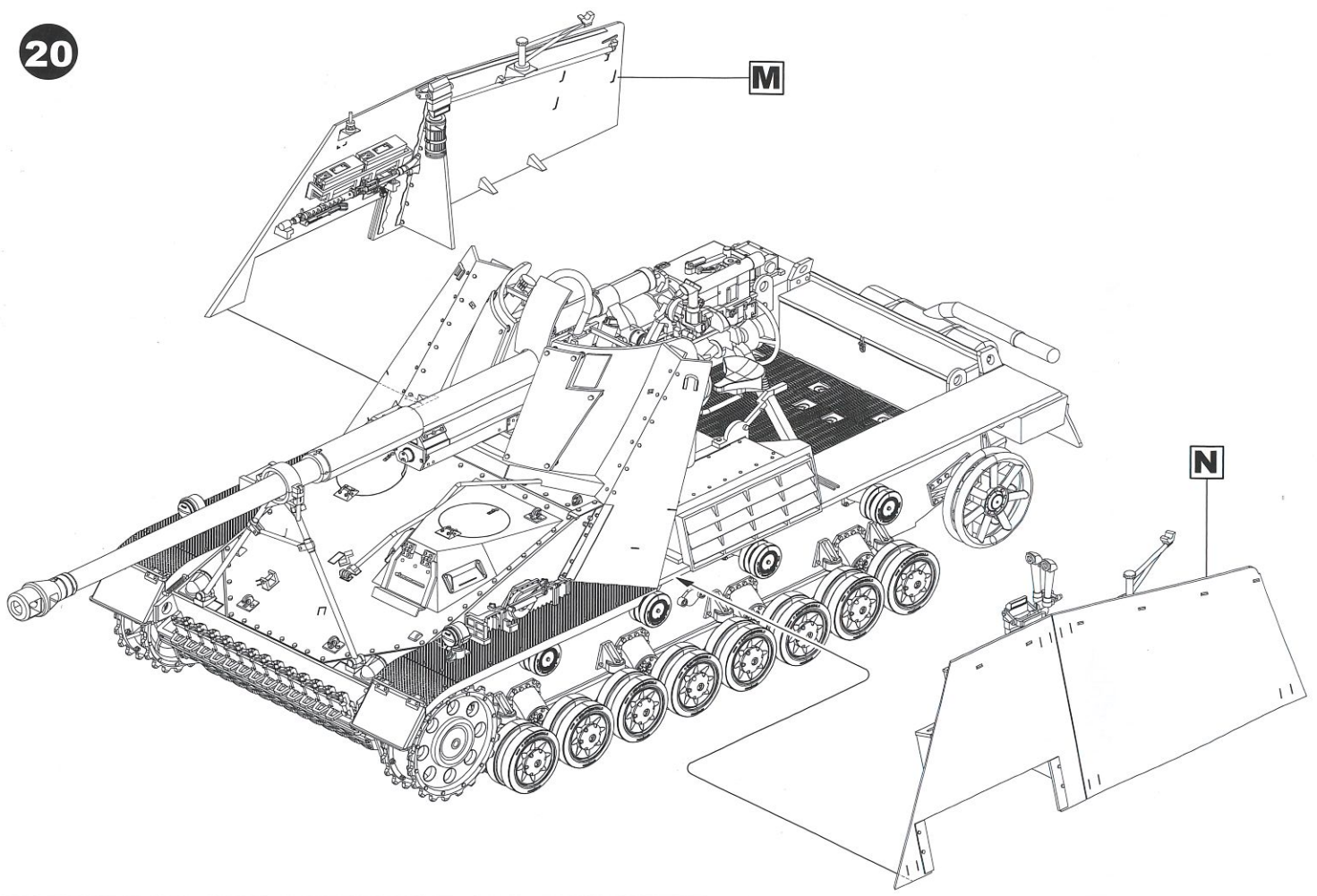

21

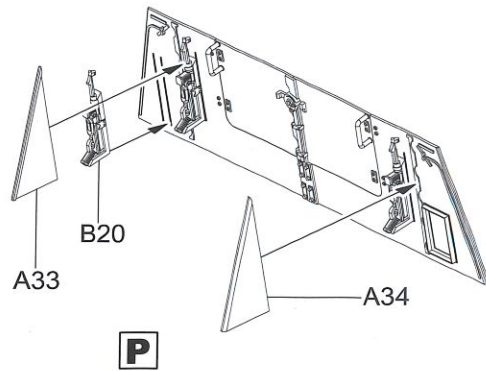
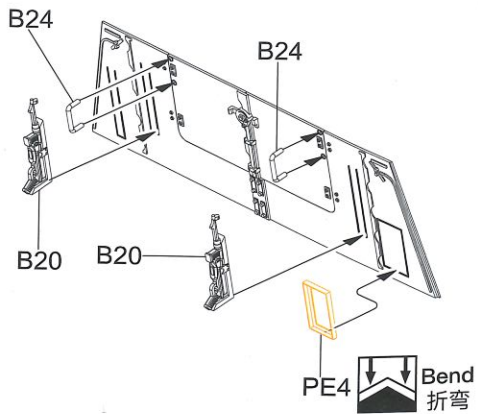
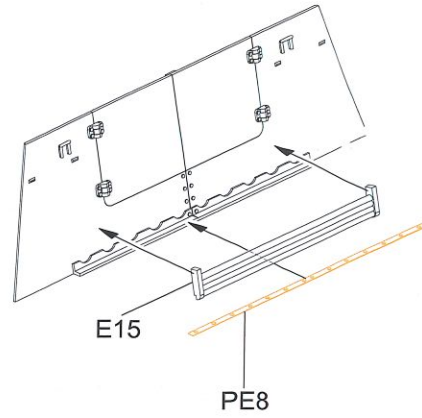
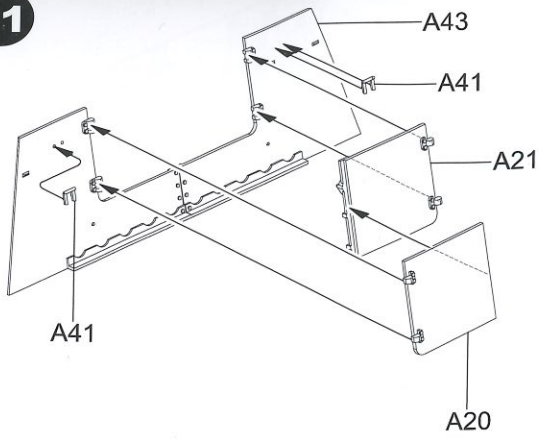

22

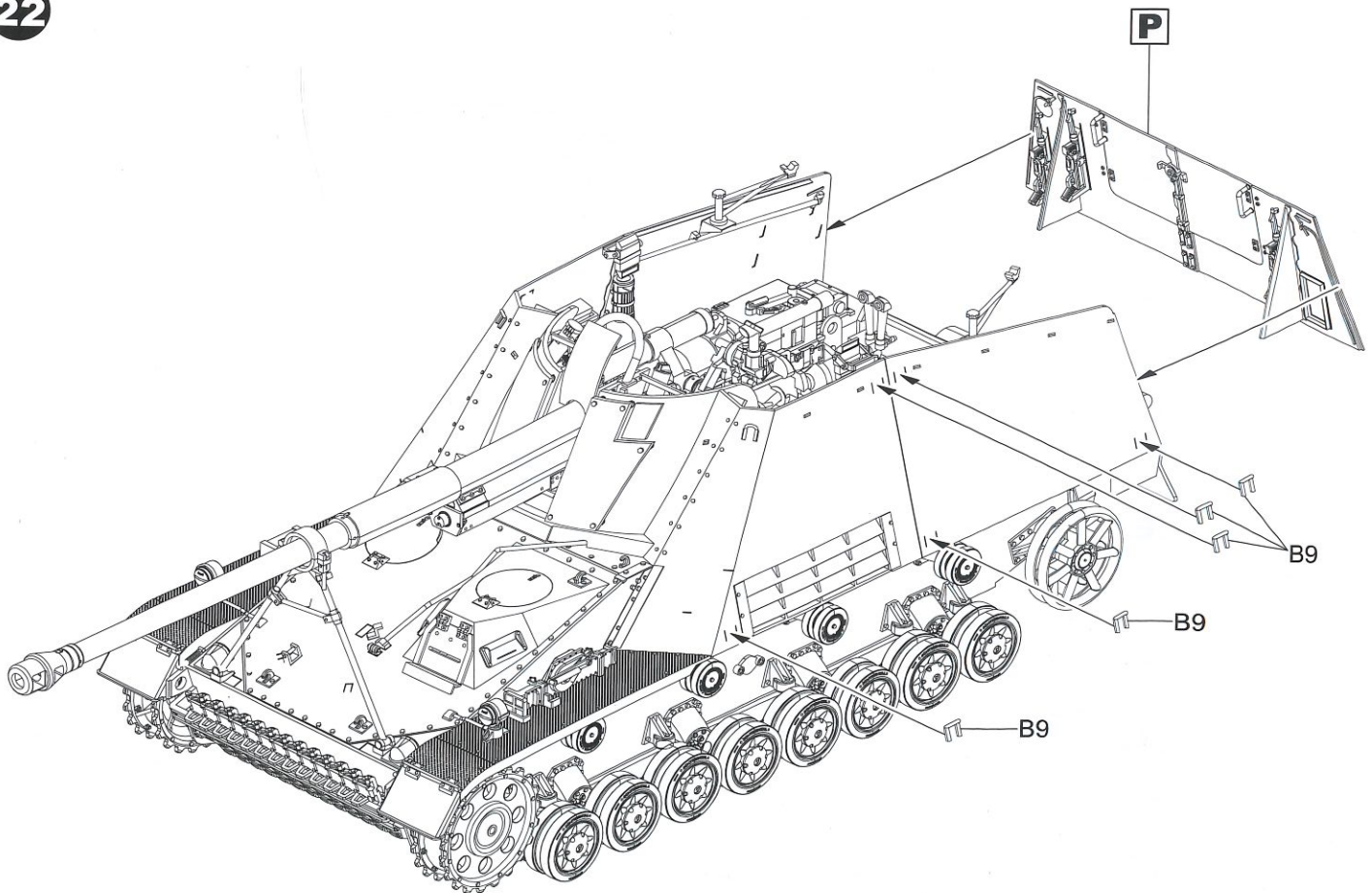

23

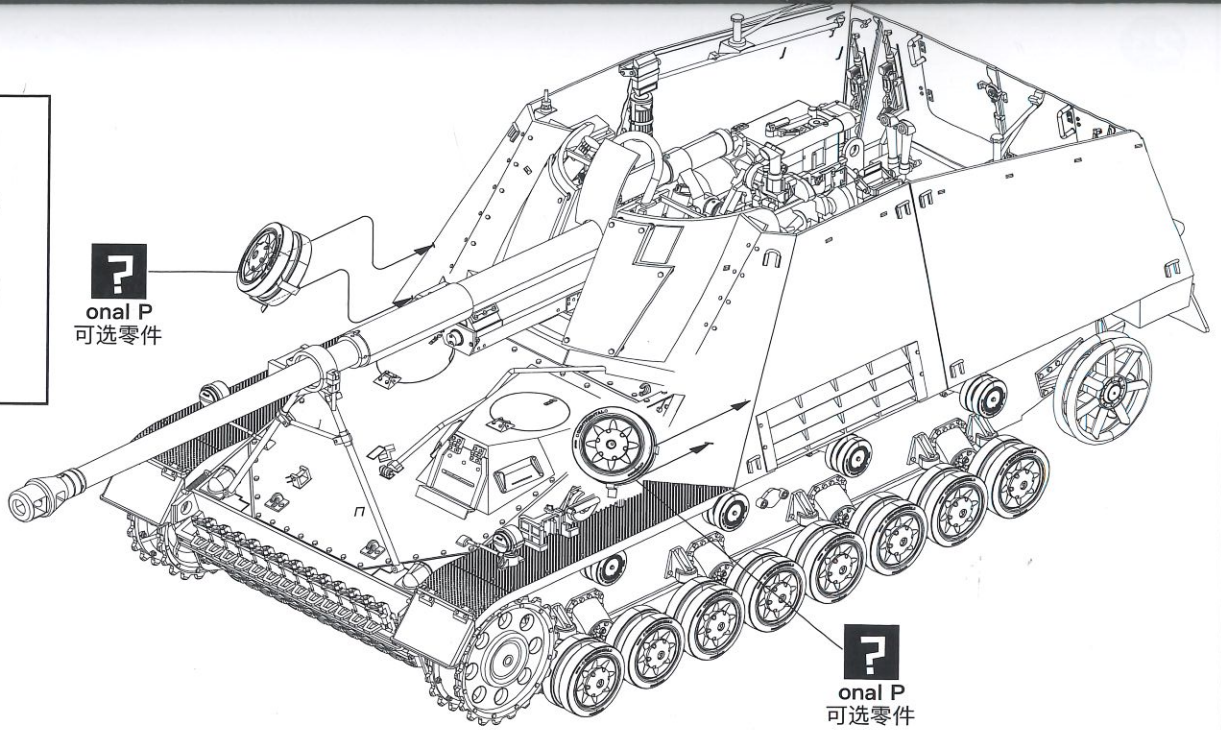
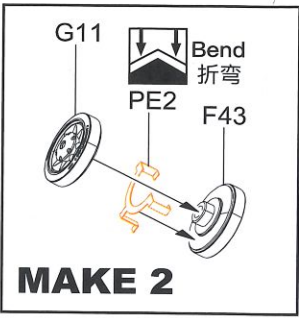

24

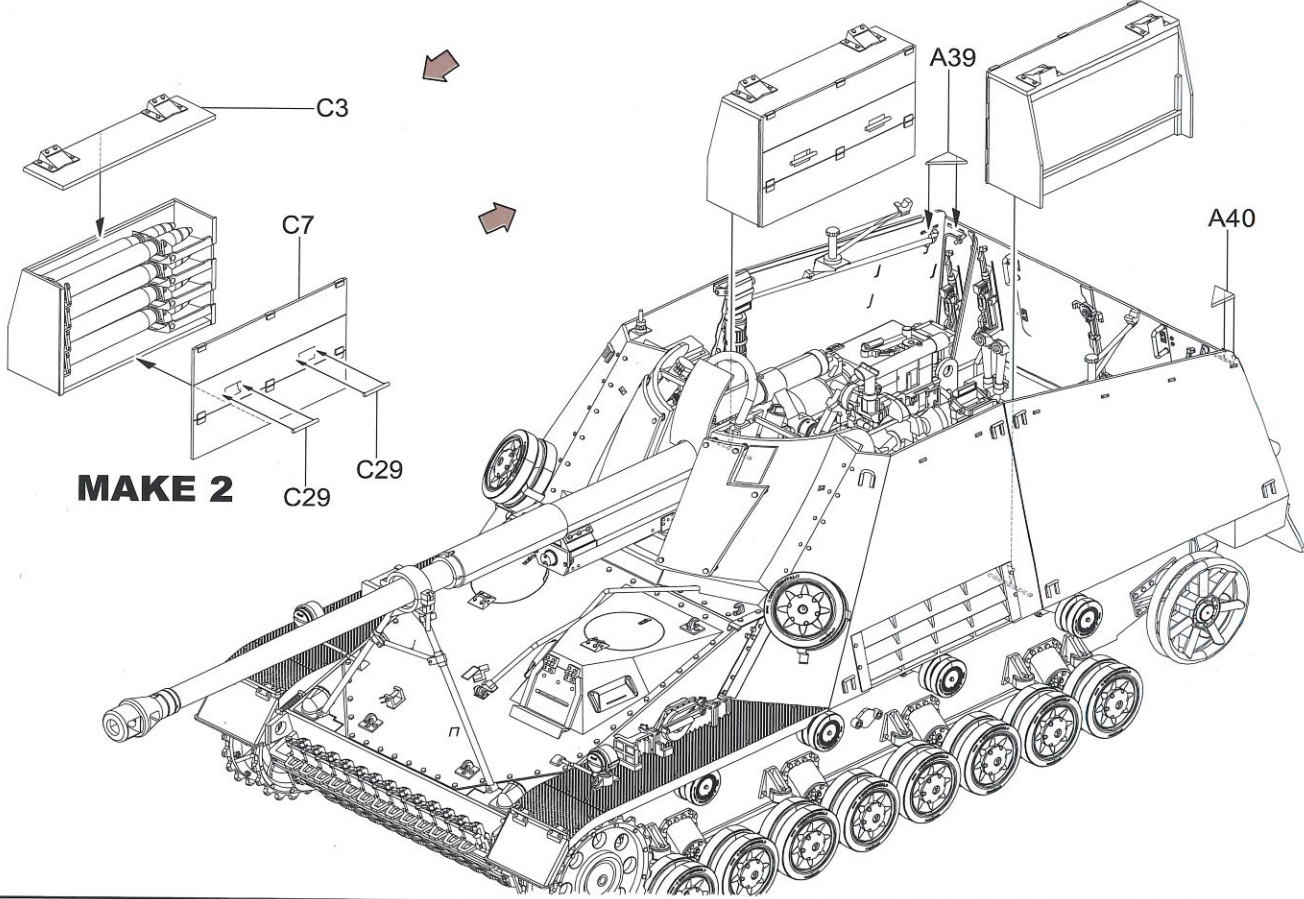
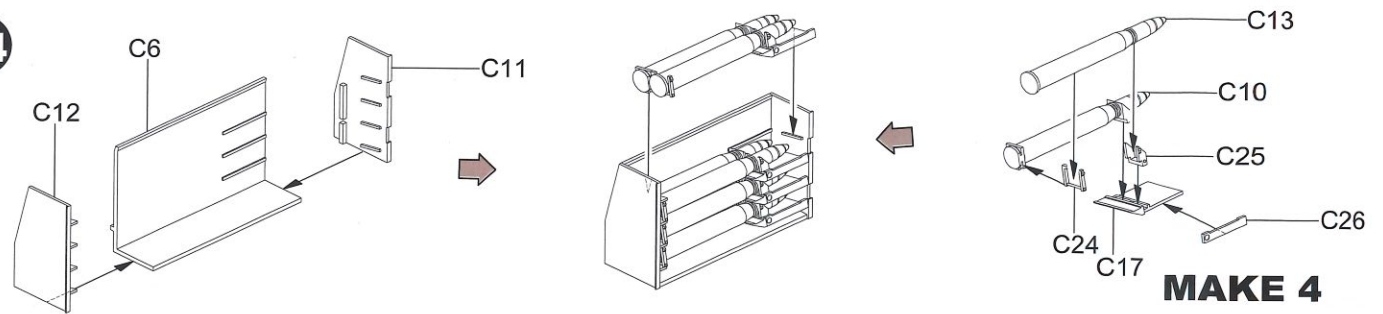

25

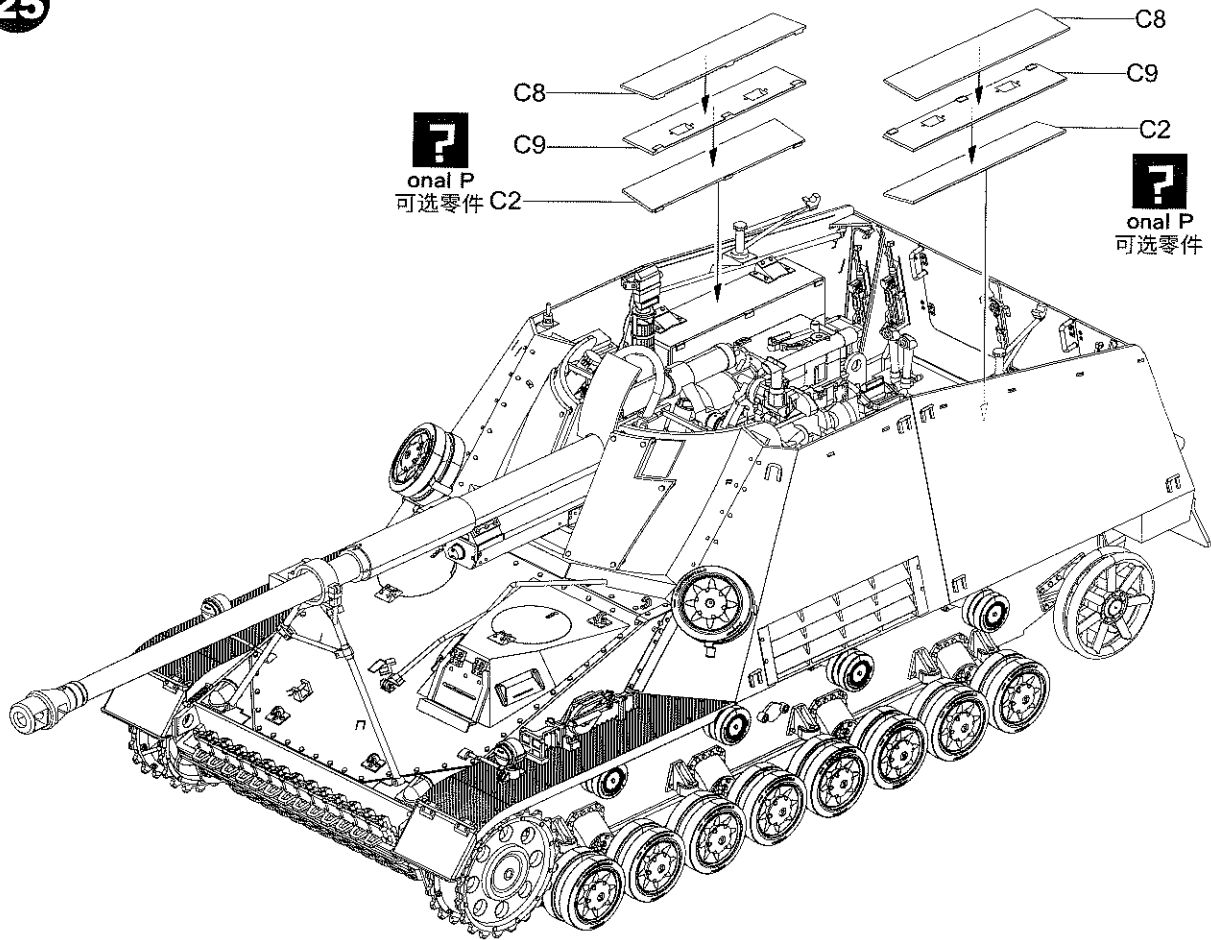

26

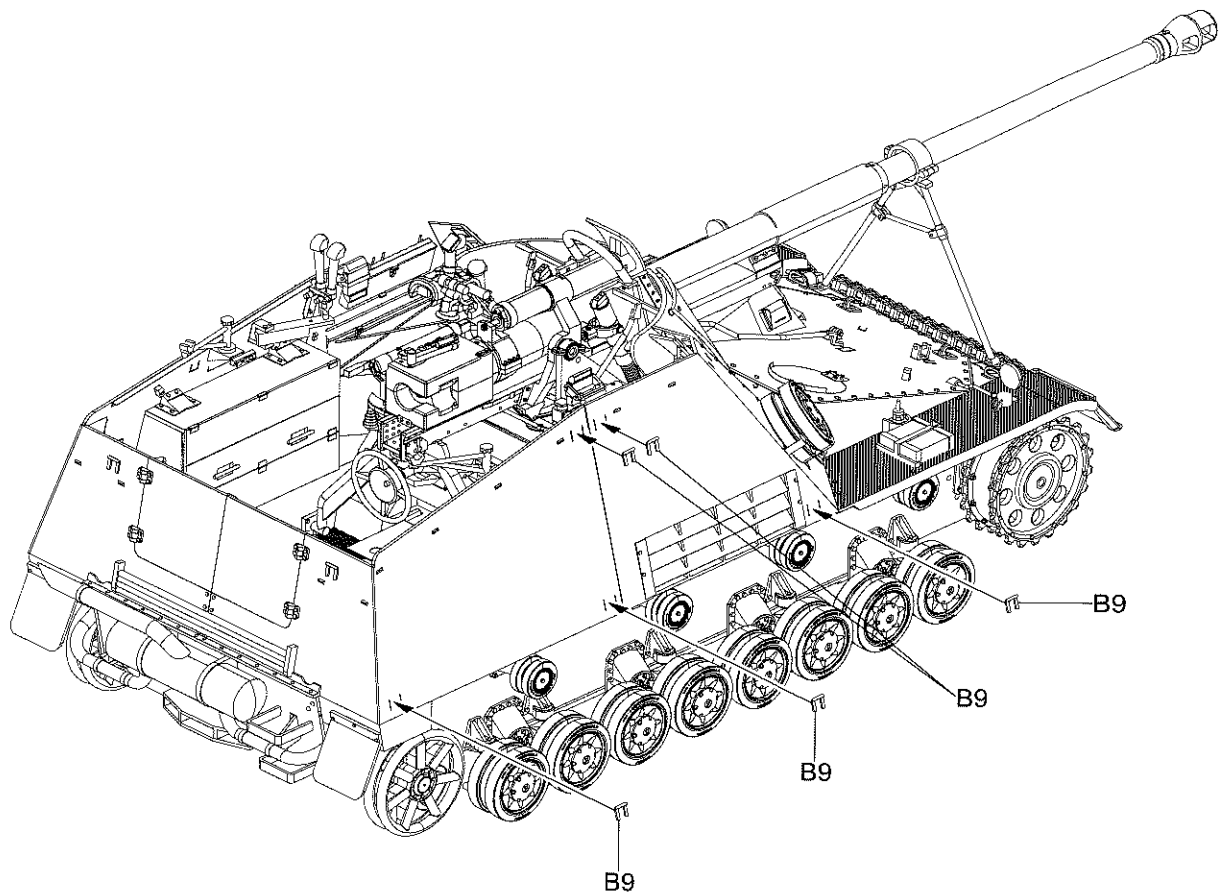

A.MIG-037 New Wood A.MIG-015 RAL 8017 SCHOKOBRAUN

A.MIG-098 Crystal Blue

A.MIG-003 RAL 6011 RESEDAGRÜN

A.MIG-033 Rubber & Tires

A.MIG-035 Gun Metal

A.MIG-035 Dark Tracks

A.MIG-011 RAL 7028 DUNKELGELB AUS '44 DG I

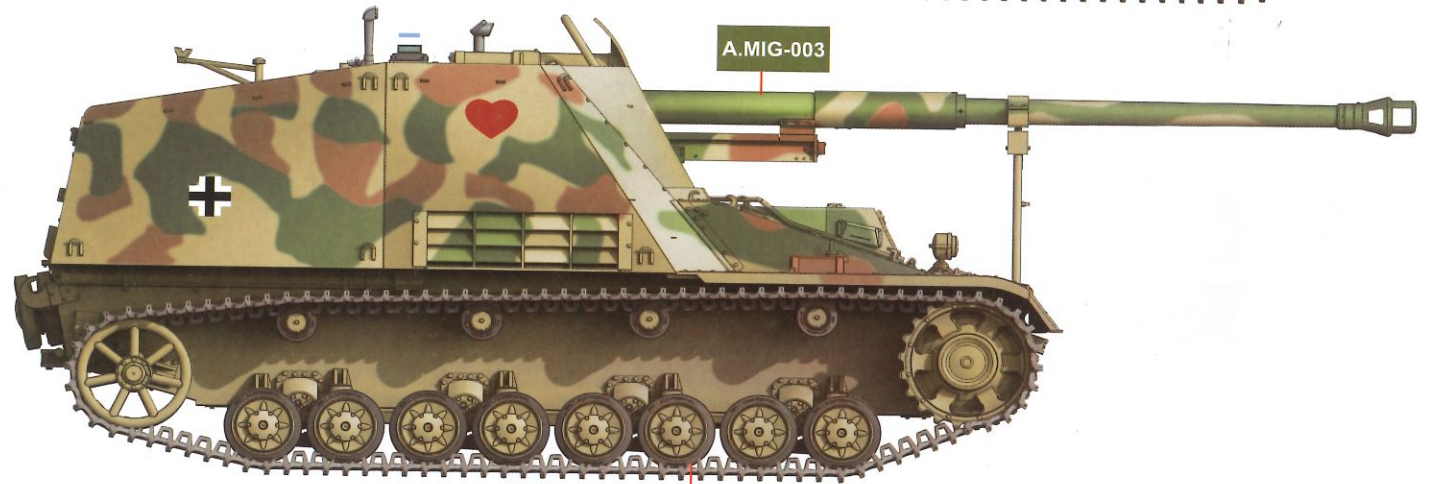
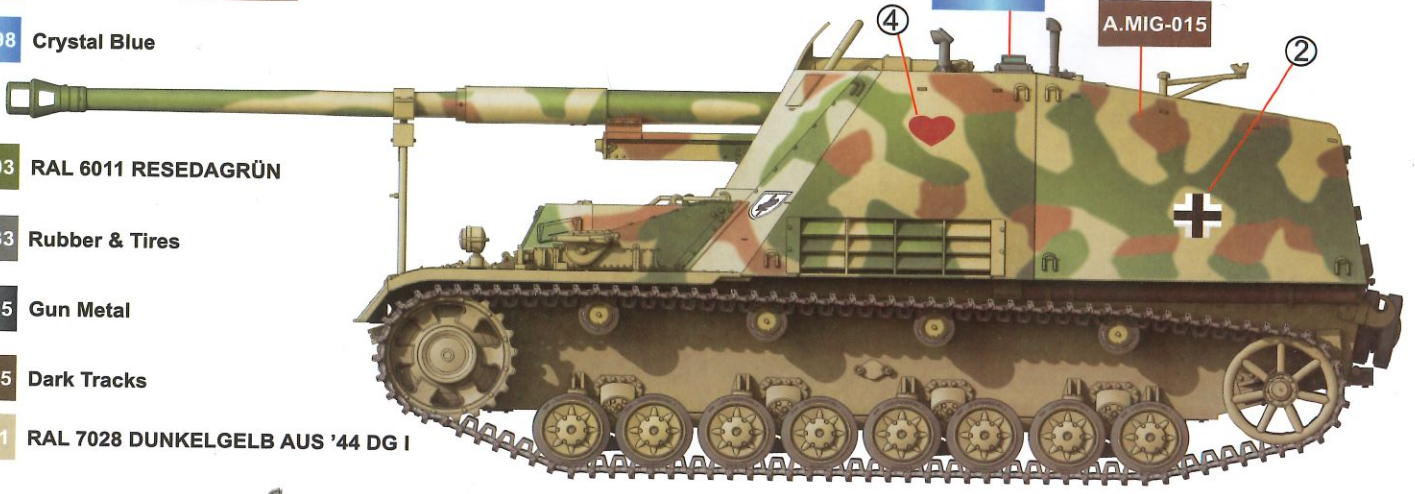

3rd Company,
88th Heavy Anti-Tank
Battalion,
Eastern Front, 1944

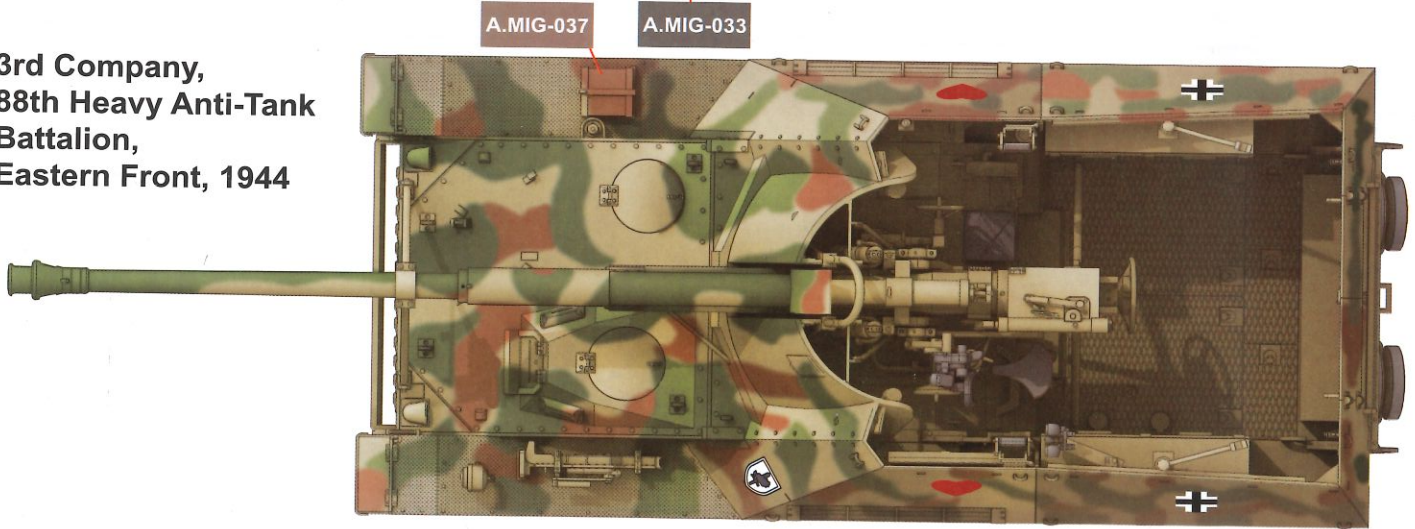

- A.MIG-037 New Wood
- A.MIG-015 RAL 8017 SCHOKOBRAUN
- A.MIG-098 Crystal Blue
- A.MIG-024 Washable White Camo

- A.MIG-003 RAL 6011 RESEDAGRÜN
- A.MIG-033 Rubber & Tires
- A.MIG-035 Gun Metal
- A.MIG-035 Dark Tracks
- A.MIG-011 RAL 7028 DUNKELGELB AUS '44 DG I

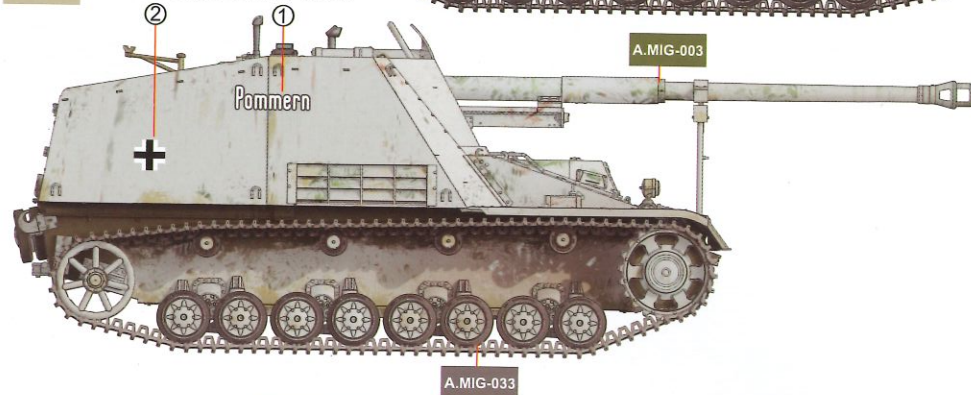

519th Heavy Anti-Tank Battalion, Eastern Front, 1944

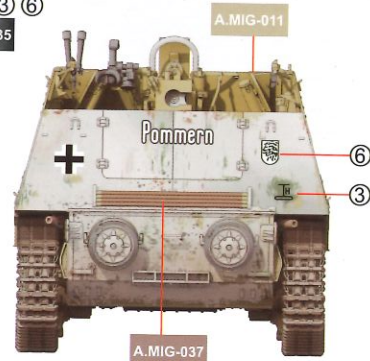
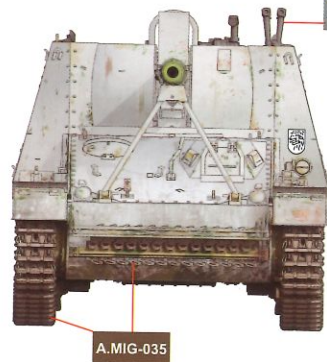
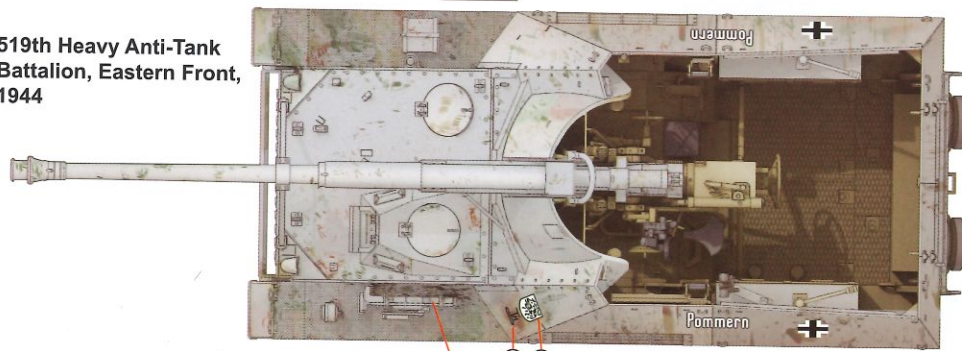

- A.MIG-037 New Wood
- A.MIG-015 RAL 8017 SCHOKOBRAUN
- A.MIG-098 Crystal Blue

- A.MIG-003 RAL 6011 RESEDAGRÜN
- A.MIG-033 Rubber & Tires
- A.MIG-035 Gun Metal
- A.MIG-035 Dark Tracks
- A.MIG-011 RAL 7028 DUNKELGELB AUS '44 DG I

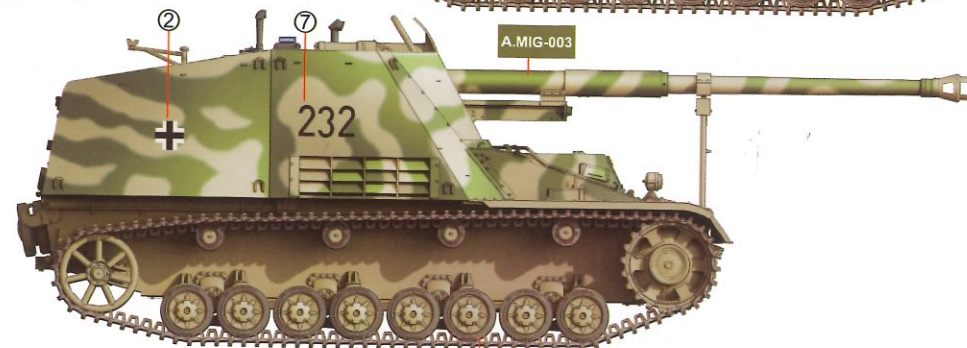

s.H.Pz.Jg.Abt.560, Russia 1943

