



1:72 Messerschmitt Me410A-1/U2 & U4

A04066 SCALE MODEL CONSTRUCTION KIT | Wingspan: 226mm Fuselage Length: 175mm | Two Decal Schemes Included

EN The Messerschmitt Me410 was developed as a heavy fighter but went on to perform several roles such as night fighter, bomber destroyer and reconnaissance. Entering service two years later than scheduled in 1943 as a replacement for the Me210, the aircraft featured several distinctive features including the twin gun barbettes. The Me210 had been found severely lacking across the board, but its major problem was its handling characteristics, the aircraft was inherently unstable which led to an unacceptably high accident rate. The Me410 was essentially a development of the 210 featuring a lengthened fuselage, revised wings and more powerful engines. Both the Me210 and Me410 were designed to replace the ageing Bf110 in a number of roles but this did not occur, the Bf110 continued to soldier on in a number of different guises until the war's end despite becoming obsolete. Although the Me410 performed well, it entered service too late to make an impact on the tide of war and was soon relegated to reconnaissance roles. Only two examples are known to survive, one on display at the RAF Museum, the other in storage in the US.

FR Le Messerschmitt Me 410 a été conçu comme chasseur lourd mais a ensuite rempli plusieurs rôles tels que chasseur de nuit, destructeur de bombardiers et avion de reconnaissance. Entré en service en 1943, deux ans plus tard que prévu, en remplacement du Me 210, l'avion présentait plusieurs caractéristiques distinctives, dont des barbettes à deux canons. Le Me 210 présentait de sérieuses lacunes dans tous les domaines, mais son principal problème résidait dans sa maniabilité, l'avion étant intrinsèquement instable, ce qui a entraîné un taux d'accidents inacceptable. Le Me 410 était essentiellement une évolution du 210 avec un fuselage allongé, des ailes revues et des moteurs plus puissants. Le Me 210 et le Me 410 ont été conçus pour remplacer le Bf 110 vieillissant dans un certain nombre de rôles, mais cela ne s'est pas réalisé dans les faits : le Bf 110 est resté en service dans diverses configurations jusqu'à la fin de la guerre, bien qu'il soit devenu obsolète. Bien que performant, le ME 410 est entré en service trop tard pour avoir une influence sur le cours de la guerre et a été rapidement relégué à des rôles de reconnaissance. Seuls deux exemplaires ont survécu : l'un est exposé au musée de la RAF, l'autre est entreposé aux États-Unis.

DE Ursprünglich als schweres Jagdflugzeug entwickelt, wurde die Messerschmitt Me410 schließlich in mehreren Rollen wie etwa als Nachtjäger, Zerstörer und Aufklärungsflugzeug verwendet. Zwei Jahre später als geplant, wurde sie 1943 als Nachfolger der Me210 in Dienst gestellt. Sie stach durch mehrere markante Merkmale hervor, einschließlich ihrer MG-Zwilling-slafetten. Bei der Me210 hatten sich mehrere ernsthafte Mängel herausgestellt, vor allem im Flugverhalten. Sie neigte zum Überziehen und Trudeln, was zu einer nicht hinnehmbaren Unfallrate führte. Grundsätzlich basierte die Konstruktion der Me410 auf der Me210, war jedoch mit einem verlängerten Rumpf, neu gestalteten Flügeln und kräftigeren Motoren ausgestattet worden. Sowohl die Me210 als auch die Me410 waren zum Ersatz der technisch überholten Bf110 in mehreren Rollen ausersehen gewesen. Tatsächlich geschah das dann aber nicht, und die Bf110 diente trotz ihrer Rückständigkeit weiterhin als Lückenbüßer in unterschiedlichen Ausführungen bis zum Kriegsende. Obwohl die Me410 sich gut bewährte, konnte sie durch ihren späten Einsatz nur wenig auf den Kriegsverlauf Einfluss nehmen und wurde bald nur noch für Aufklärungszwecke eingesetzt. Nur zwei Exemplare sind davon erhalten – eines ist im RAF-Museum in London ausgestellt, während sich das zweite in den USA befindet.

Specification

Maximum Speed: 315 mph (507 km/h) at sea level

Range: 750 miles (1200 km)

Wingspan: 53 ft 8 in (16.36 m)

Length: 40 ft 12 in (12.5 m)

Armament: 2 x 7.92 mm MG 17 in the nose, 2 x MG151/20 & up to 1000kg of bombs

Spécification:

Vitesse maximale: 507 km/h au niveau de la mer

Rayon d'action : 1200 km

Envergure: 16,36 m

Longueur: 12,5 m

Armement: 2 mitrailleuses MG 17 de 7,92 mm dans le nez, 2 MG 151/20 et jusqu'à 1 000 kg de bombes

Spezifikation:

Höchstgeschwindigkeit: 507 km/h auf Meereshöhe;

Reichweite: 1200 km

Spannweite: 16,36 m

Länge: 12,5 m

Bewaffnung: zwei 7,92 mm MG 17 im Bug, zwei MG151/20 und bis zu 1000 kg Bomben

Airfix would like to thank the RAF Museum and Lynn Ritger for their assistance in the development of this model

FOR BEST RESULTS:

Surfaces to be painted should be clean – before parts are removed from the sprue, wash in warm, soapy water, rinse and dry thoroughly. Stir paints thoroughly before use.

PLEASE NOTE:

Some parts in the kit may not be required to build the model specified.

**HORNBY
HOBBIES**



Manufactured by: Hornby Hobbies Ltd Westwood, Margate, Kent, CT9 4JX, UK +44(0)1843 233525 customerservices.uk@hornby.com

EU Authorised Representative: Hornby Italia SRL Viale dei Caduti, 52/A6, Castel Mella (BS), Italy, 25030 +39 0687501292 customerservices.it@hornby.com

ES El Messerschmitt Me410 se diseñó como caza pesado, pero desempeñó distintas funciones, como caza nocturno, bombardero destructor y de reconocimiento. Entró en servicio en 1943, dos años después de lo previsto, para sustituir al Me210, y contaba con varias características exclusivas, como la doble barbata en las ametralladoras. El Me210 había presentado importantes deficiencias generales, pero su principal problema radicaba en el sistema de manejo: el aparato era inherentemente inestable, lo que propició una tasa de accidentes inaceptable. El Me410 era en esencia un desarrollo del 210 con fuselaje prolongado, alas con diseño revisado y motores de mayor potencia. Tanto el Me210 como el Me410 se crearon para sustituir al envejecido Bf110 en distintas funciones, pero esto no llegó a suceder: a pesar de estar obsoleto, el Bf110 siguió cumpliendo su misión con distintos exteriores hasta el final de la guerra. Aunque ofrecía buenas prestaciones, el Me410 entró en servicio demasiado tarde como para influir en el curso de la guerra y no tardó en quedar relegado a funciones de reconocimiento. Solo se han conservado dos unidades: una se exhibe en el Museo de la RAF y la otra permanece en un almacén en EE. UU.

SV Messerschmitt Me410 utvecklades som ett tungt stridsflygplan men fick tjänstgöra i olika roller som vid nattstrid, bombing och spionage. Planet togs i bruk två år senare än planerat 1943 som en ersättning för Me210 och var utrustat med flera utmärkande funktioner, bland annat de dubbla kulsprutebarbeterna. Me210 hade flera brister, men det största problemet var dess hantering. Planet var ökänt instabil vilket ledde till en oacceptabelt hög olycksnivå. Me410 var i grund och botten en utveckling av 210 med en längre flygkropp, reviderade vingar och kraftfullare motorer. Både Me210 och Me410 utvecklades för att ersätta den gamla Bf110 i flera olika roller, men det blev inte så. Bf110 fortsatte att användas i olika versioner till krigsslutet trots att det blivit förlästat. Trots att Me410 presterade väl kom det i tjänst för sent för att påverka utgången av kriget och förpassades snart till spaningsuppdrag. Endast två kända exemplar finns kvar, ett på RAF-museet och det andra finns på ett lager i USA.

Especificación:
Velocidad máxima: 507 km/h a nivel del mar
Autonomía: 1200 km
Envergadura: 16,36 m
Longitud: 12,5 m
Armamento: 2 ametralladoras MG 17 de 7,92 mm en el morro, 2 MG151/20 y hasta 1000 kg de bombas

Spekifikation:
Toppfart: 507 km/h vid havsytan
Räckvidd: 1 200 km
Spännvidd: 16,36 m
Längd: 12,5 m
Bestyckning: 2 x 7,92 mm MG 17 i nosen, 2 x MG151/20 och upp till 1 000 kg bomblast

ASSEMBLY INSTRUCTIONS

EN Study drawings and practise assembly before cementing parts together. Carefully scrape paint from cementing surfaces. All parts are numbered. Paint small parts before assembly. To apply decals cut sheet as required, dip in warm water for a few seconds, slide off backing into position shown. Use in conjunction with box artwork. Not appropriate for children under 36 months of age, due to the presence of small detachable parts.

FR Étudier attentivement les dessins et simuler l'assemblage avant de coller les pièces. Grattez soigneusement toute peinture sur les surfaces à coller. Toutes les pièces sont numérotées. Peindre les petites pièces avant l'assemblage. Pour coller les décalcomanies, découper le motif, le plonger quelques secondes dans de l'eau chaude puis le poser à l'endroit indiqué en décollant le support papier. Utiliser conjointement avec les illustrations sur la boîte. Ne convient pas aux enfants de moins de 36 mois - présence de petits éléments détachables.

DE Vor dem Zusammenkleben der Teile die Zeichnungen sorgfältig ansehen und die zu verklebenden Teile zur Vermeidung möglicher Fehler versuchsweise zusammenfügen. Dann an den Klebeflächen vorhandene Farbbeschichtung vor dem Zusammenkleben vorsichtig abkratzen. Alle Bestandteile sind mit Nummern versehen. Kleine Teile vor dem Zusammenbau bemalen. Abziehbilder wie gewünscht ausschneiden. Vor dem Anbringen einige Sekunden in warmes Wasser tauchen und dann vom Trägerpapier in ihre vorgesehene Position schieben. Dabei die Abbildungen auf der Schachtel beachten. Nicht für Kinder unter 36 Monaten geeignet, da abnehmbare bzw. lose angebrachte Kleinteile enthalten sind.

ES Estudiar los dibujos y practicar el montaje antes de pegar las piezas. Raspas cuidadosamente la pintura en las superficies de contacto antes de pegar las piezas. Todas las piezas están numeradas. Es conveniente pintar las piezas pequeñas antes de su montaje. Para aplicar las calcomanías, cortarlas de la hoja, sumergirlas en agua tibia durante unos segundos y deslizarlas a la posición indicada. Utilizar en conjunción con la ilustración de la caja. No es adecuado para niños menores de 36 meses, ya que contiene piezas pequeñas que podrían soltarse.

SV Studera bilderna noggrant och sätt ihop delarna innan du limmar ihop dem. Skrapa försiktigt bort färg från limmade delar. Alla delarna är numrerade. Måla smådelarna före ihopsättning. Sätt fast dekalerna genom att klippa arket, doppa i varmt vatten några sekunder och låta baksidan glida på plats som bilden visar. Använd enligt bildanvisningarna på kartongen. Rekommenderas ej för barn under 3 år. Innehåller löstagbara smådelar.

NL Tekeningen bestuderen en delen in elkaar zetten alvorens deze te lijmen. Lak voorzichtig van lijmvlakken afschrapen. Alle delen zijn genummerd. Kleine delen vóór montage verven. Voor aanbrengen van stickers, gewenste stickers uit het vel knippen, een paar seconden in warm water dompelen en dan van het schutblad af op afgebeelde plaats schuiven. Hierbij afbeelding op doos raadplegen. Niet geschikt voor kinderen onder 3 jaar, omdat kleine deeltjes gemakkelijk kunnen losraken.

PO Przed przystąpieniem do sklejania przestuduj uważnie rysunki i przećwicz składanie części. Ostrożnie zeskrob ze sklejanych powierzchni farbę. Wszystkie części są ponumerowane. Drobnie części pomaluj przed ich złożeniem. Celem przeniesienia kalkomanii wytnij ją z arkusza, zanurz na kilka sekund w letniej wodzie i zsuń z podłoża na wymaganie miejsce. Używaj w połączeniu ze wzorami na pudełku. W związku z obecnością wielu drobnych, rozbiernych części, nieodpowiednie dla dzieci poniżej 3 lat.

IT Studiare i disegni ed esercitarsi a montare i vari pezzi prima di fissarli con la colla. Raschiare con cura le tracce di vernice dalle superfici da incollare. Tutti i pezzi sono numerati. Verniciare i pezzi di piccole dimensioni prima di montarli. Per applicare le decalcomanie, ritagliare il foglio nel modo richiesto, immergere in acqua calda per alcuni secondi, quindi staccare la decalcomania dalla carta di supporto e posizionarla nel punto desiderato. Usare le decalcomanie come indicato nell'illustrazione riportata sulla confezione. Non adatto a bambini di età inferiore a 36 mesi per la presenza di componenti di piccole dimensioni che potrebbero staccarsi.

PT Estudar atentamente os desenhos e experimentar a montagem. Raspas cuidadosamente as superfícies de modo a eliminar pintura antes de colar. Todas as peças estão numeradas. Pintar as pequenas peças antes de colar. Para aplicar as decalcomanias, cortar as folhas e mergulhar em água morna por alguns segundos, depois deslizar e aplicar no respectivo lugar, como indicado nas ilustrações na caixa. Não convém a uma criança de menos de 36 meses devido à presença de pequenos elementos destacáveis.

EL Μελετήστε προσεκτικά τα σχέδια και συναρμολογήστε για πρώτη φορά τα κομμάτια χωρίς να τα συγκολλήσετε. Αφαιρέστε επιμελώς την πλαστική βαφή από τις επιφάνειες τις οποίες θα συγκολλήσετε. Όλα τα κομμάτια είναι αριθμημένα. Χρωματίστε τα μικρά κομμάτια πριν από τη συναρμολόγηση. Για να κολλήσετε τις χαλκομανίες, κόψτε γύρω από το σχέδιο όπως απαιτείται, βυθίστε το μερικά δευτερόλεπτα σε χλιαρό νερό και μετά τοποθετήστε το στη θέση που υποδεικνύεται, αφαιρώντας τη μεμβράνη που το καλύπτει. Λάβετε υπόψη σας ταυτόχρονα την εικονογράφηση του κουτιού. Ακατάλληλο για παιδιά ηλικίας κάτω των 36 μηνών λόγω ύπαρξης μικρών κομματιών που αποσπούνται.

FI Tutustu piirroksiin ja harjoittele kokoamista, ennen kuin liimaat osat yhteen. Raaputa maali varovasti pois liimattavilta pinnolta. Kaikki osat on numeroitu. Maalaa pienet osat ennen kokoamista. Siirtokuvien kiinnittämisksi leikkaa ne arkista tarpeen mukaan. Kasta kuva lämpimään veteen muutaman sekunnin ajaksi, anna takapuolen liukua kovalle osoitettuun kohtaan. Käytetään yhdessä laatikon kuvituksen kanssa. Ei suositella alle kolmivuotiaille lapsille. Paljon irrotettavia pikkuosia.

DA Studer tegningerne nøje og forsøg at sætte delene sammen, inden de klæbes sammen. Skrab forsigtigt malingen af de overflader, der skal klæbes sammen. Alle dele er nummererede. Små dele skal males, før de monteres. Overfaringsbillederne påføres ved at klippe dem ud af arket, som påkrævet, dypp dem i varmt vand i nogle få sekunder, hvorefter underlaget glides af i de viste positioner. Påføres ifølge illustrationerne på æsken. Ikke egnet til børn under 3 år på grund af tilstedeværelse af små aflagelige dele.

ASSEMBLY ICON INSTRUCTIONS

<p>Assembly phase Phase de montage Montagephase Fase de montaje Montieringfasen Fase di montaggio Montagefase Fase de montagem Monteringsfase Kokoamisvaihe Faza składowania Φάση συναρμολόγησης</p>	<p>Cement Coller Kleben Kleben Pegar Limma into Incollare Lijmen Lijmen Color Kleibes Limmaa Kleić Συγκολλήστε</p>	<p>Do not cement together No pas coller Nicht kleben Nicht kleben No pegar Limma into Non incollare Niet lijmen Nào color Skaf ikke klabes Aiã limaa Nie klei ć Mh συγκολλήστε</p>	<p>Indicates final location Indica l'emplacement final Zeigt Endposition Indica la ubicación definitiva Anger slutmonteringsplats Seede di montaggio finale Geft uiteindeilike locatie aan ? Indica localização final Viser endelig placering Osoittaa lopullisen sijainnin Oznacza miejsce docelowe Υποδεικνύει τελική τοποθεσία</p>	<p>Alternative part(s) provided Autre(s) pièce(s) fournie(s) Ersatzteil(e) mitgeliefert Se incluye(n) pieza(s) alternativa(s) Alternativ(a) del(ar) ingår Uno o più componenti alternativi forniti Alternatieve onderdelen meegeleverd Peça(s) alternativa(s) fornecida(s) Alternativ(e) del(e) medfølger Vaihtoehtoiset osat pakkauskassa Dostane część zamienną Παρέχονται εναλλακτικά κομμάτια</p>	<p>Repeat this operation Répéter l'opération Wznowić wiederholen Wznowić l'opération Upprepa åtgärden Ripetere l'operazione De verrichting herhalen Repeter a operação Manavnen gentages Toista toimintapide Powtórz ć operacj e Επανάλαβετε τη διαδικασία</p>	
<p>Decals Décalcomanias Abziehbild Calcomanias Dekaler Decalcomanie Stickers Decalcomania Billedoverføring Siirtokuvat Kalkomanie Χαλκομανίες</p>	<p>Crystal part Pièce cristal Kristallteil Piazza de cristal Kristalldel Pezzo cristallo Kristallin osat Kryształowa część Κρυστάλινα κομμάτια</p>	<p>Weight Lester Beschweren Lastrar Belasta Applicare un peso ? Verzwaren Lastrar Påfør vægt Aseta vastapaino Obci ażyc balastem Επιθέστε βάρος</p>	<p>Remove by filing Enlever avec une lime Abfeilen Elimnar con lima Ta bort genom att fila Ritnuovere con la lima Verwijderen door afvlijen Remova limando Fjern ved at file væk Poista viljamalla Usunaj przy użyciu pilnika Αφαιρέστε λιμάροντας με λίμα</p>	<p>Drill or pierce Perforer Durchbohren Perforar Boira Trapanare o forare Boren of doorboren Furar Gennembor Poraa tai puhkaise Wywierć ć lub przedziurawić Τρυπήστε</p>	<p>Cut Découper Schneiden Cortar Skär Sniijden Furar Skær Leikáa Przeciać Κόψτε</p>	<p>Humbrol paint number No peinture Humbrol Humbrol-Farbrnummer No de pintura Humbrol Humbrol färg nummer No vertice Humbrol Humbrol verfummer No de pintura Humbrol Humbrol-maalin numero Nr farby Humbrol Νόμepo χρώματος Humbrol</p>

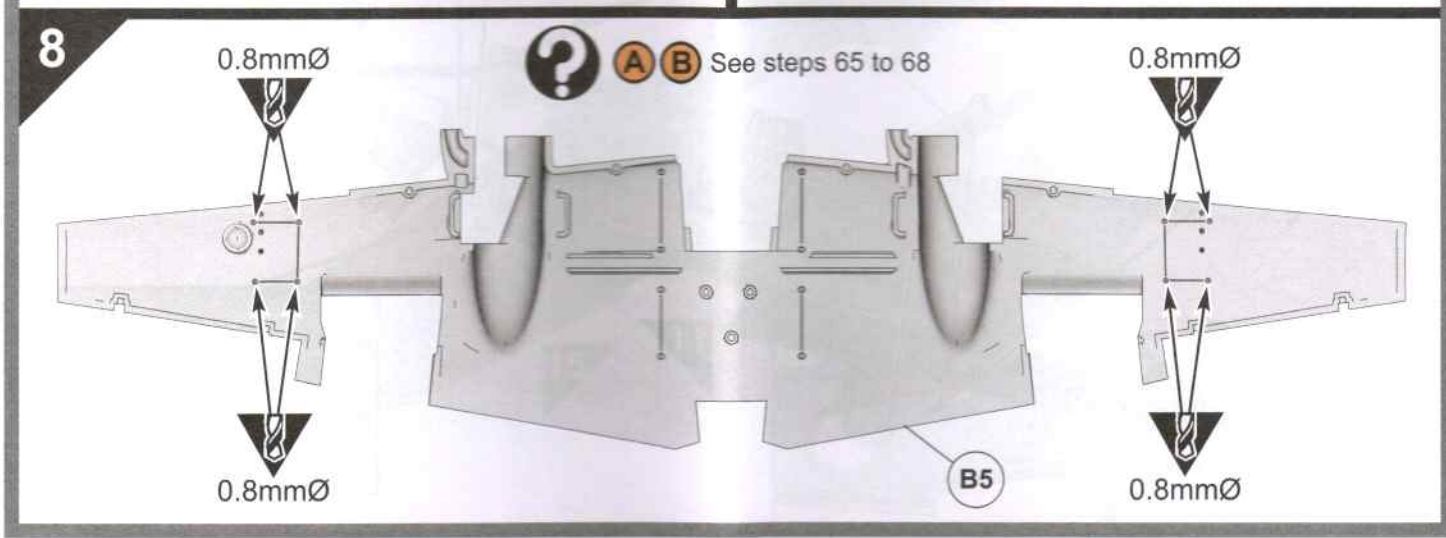
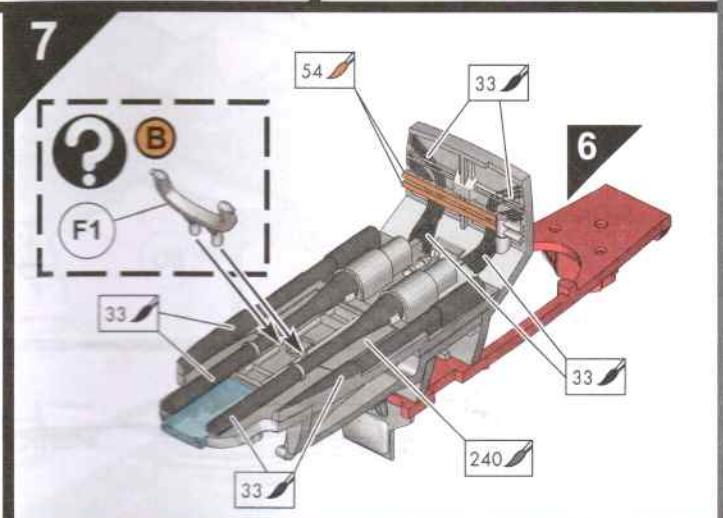
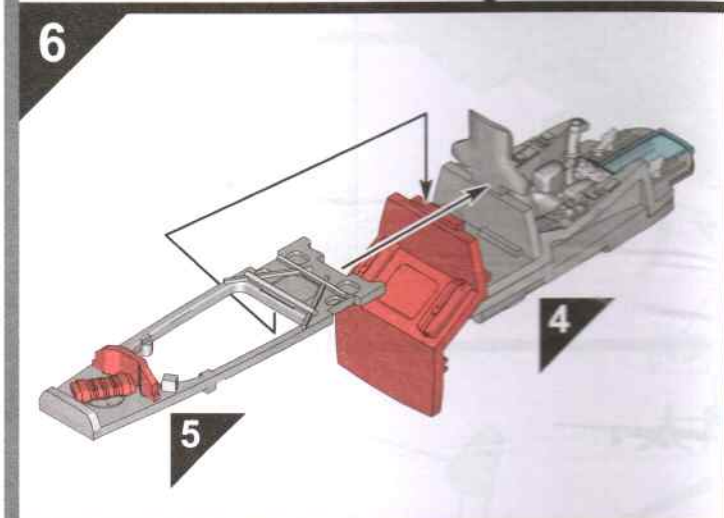
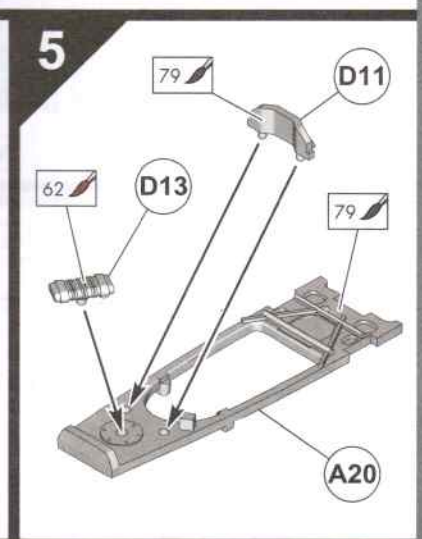
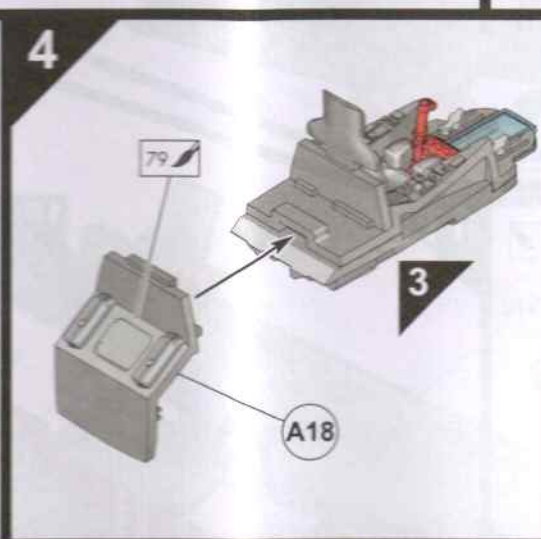
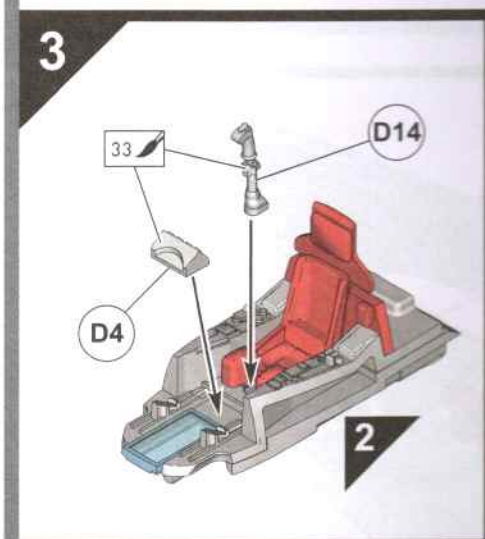
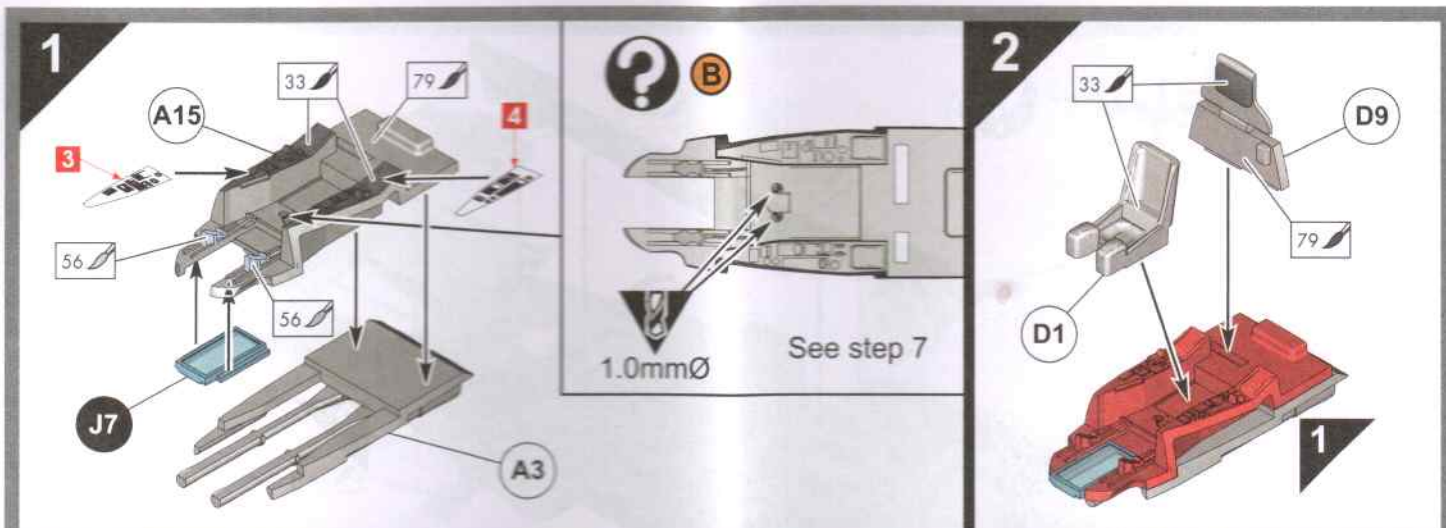

9

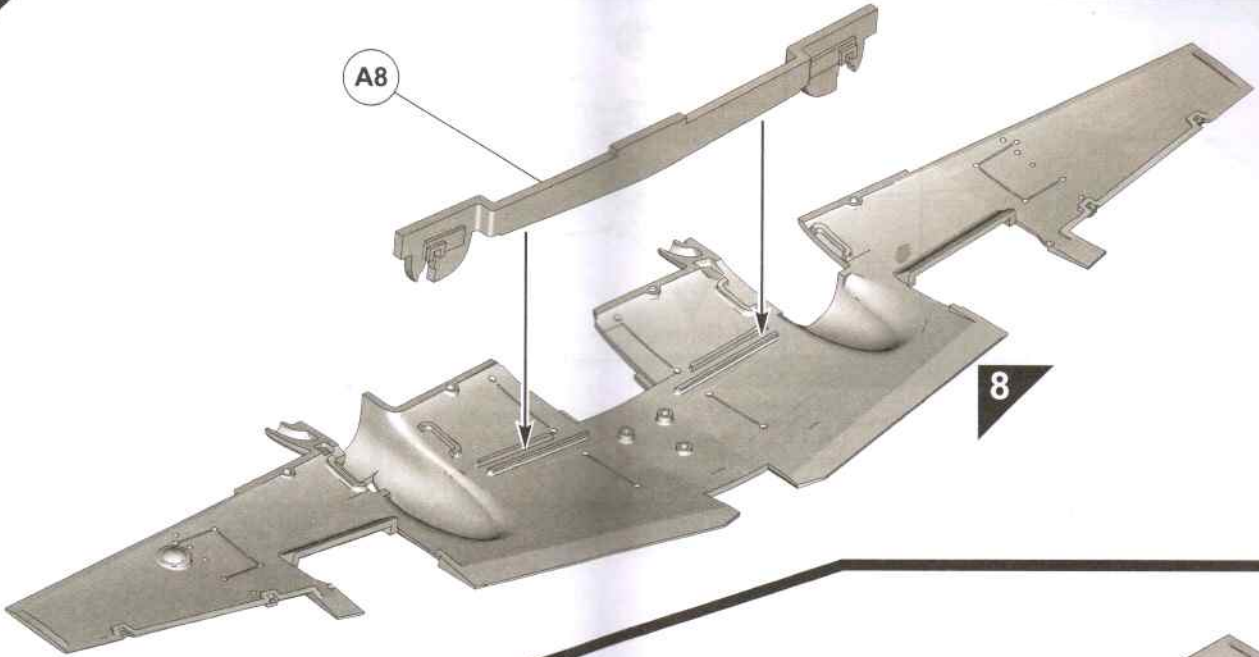

10

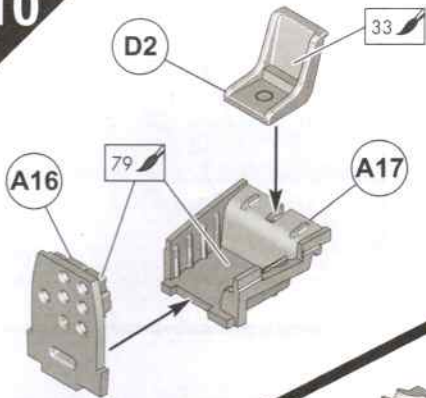

11

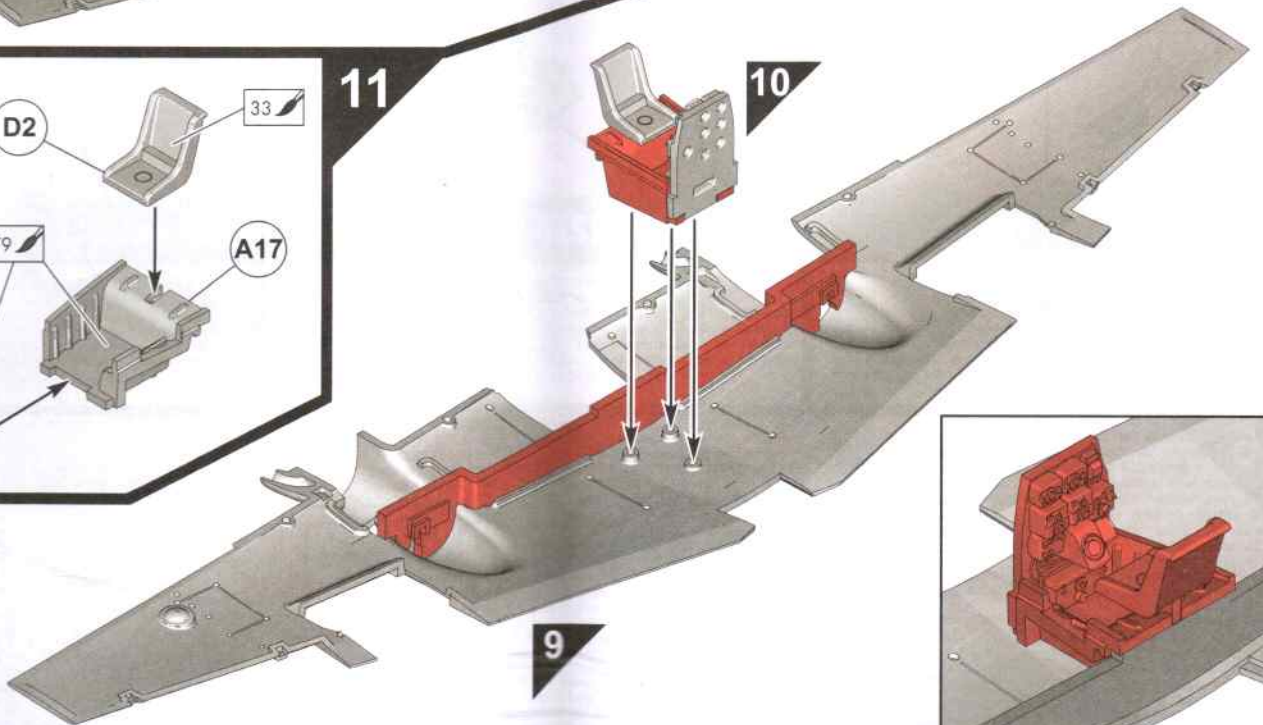

12

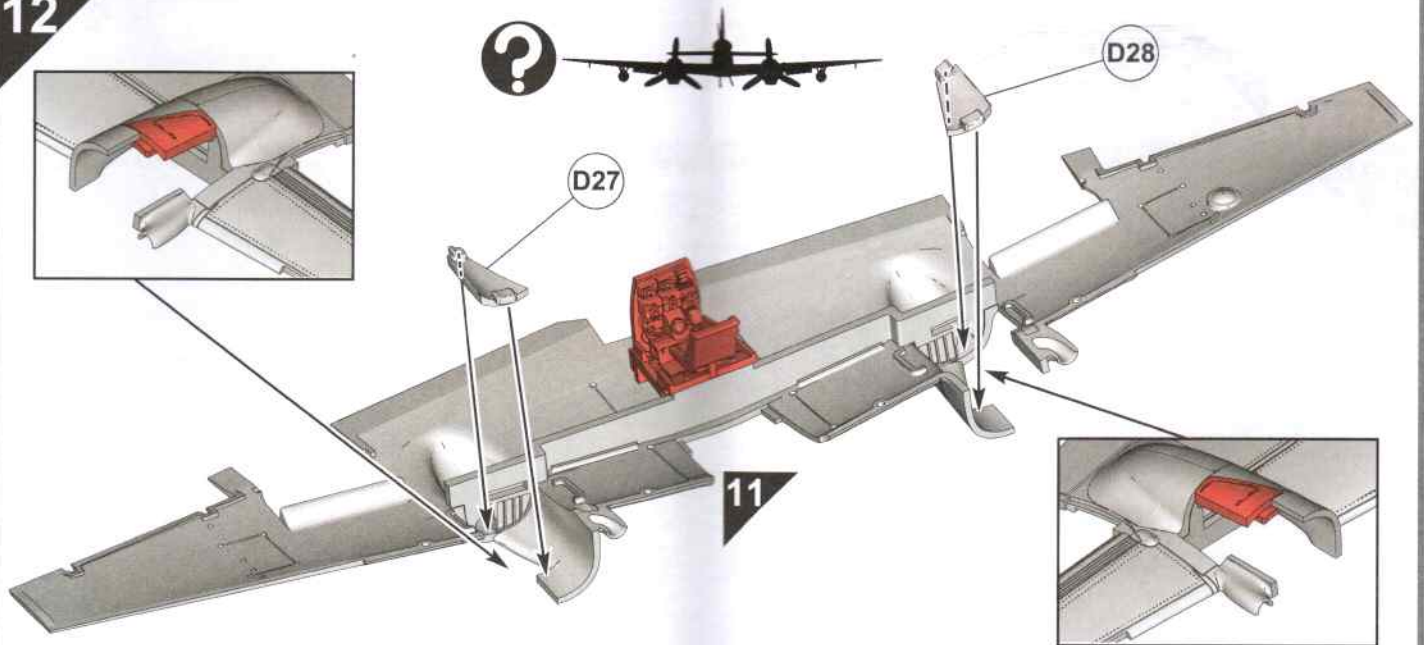

13

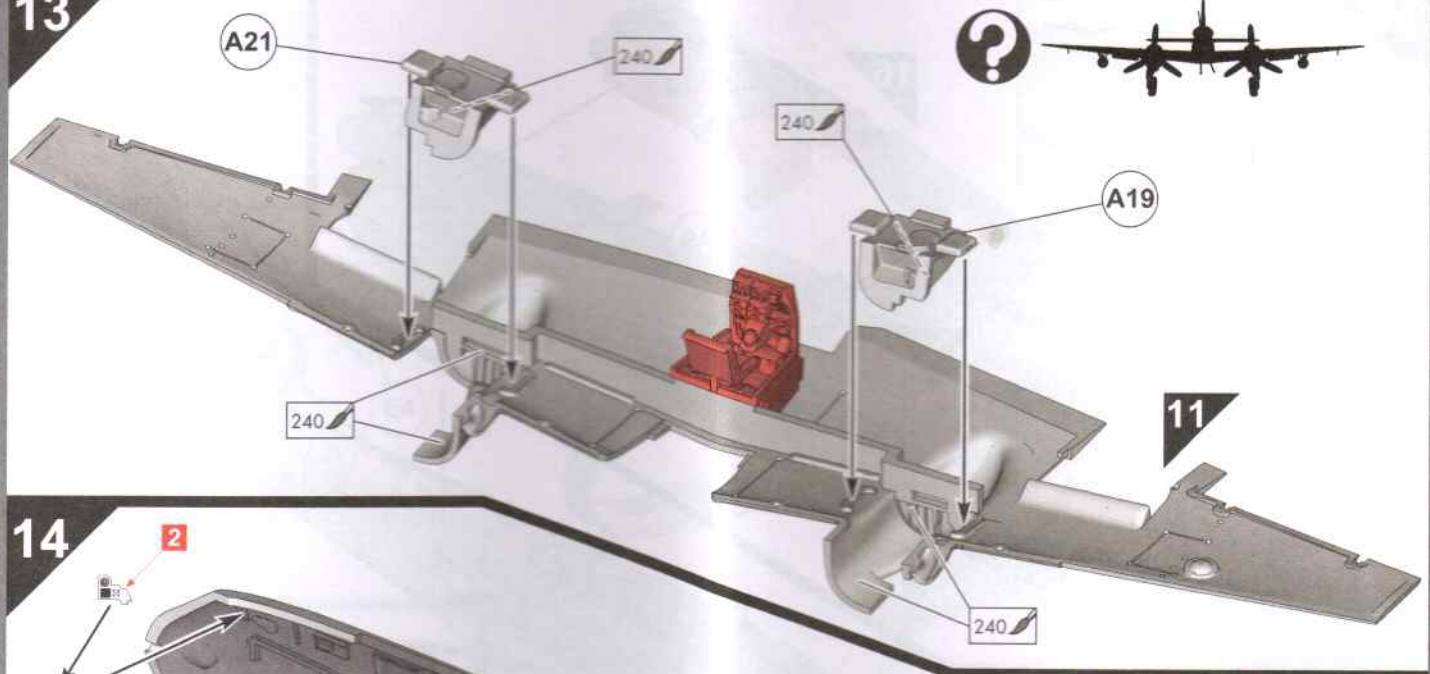

14

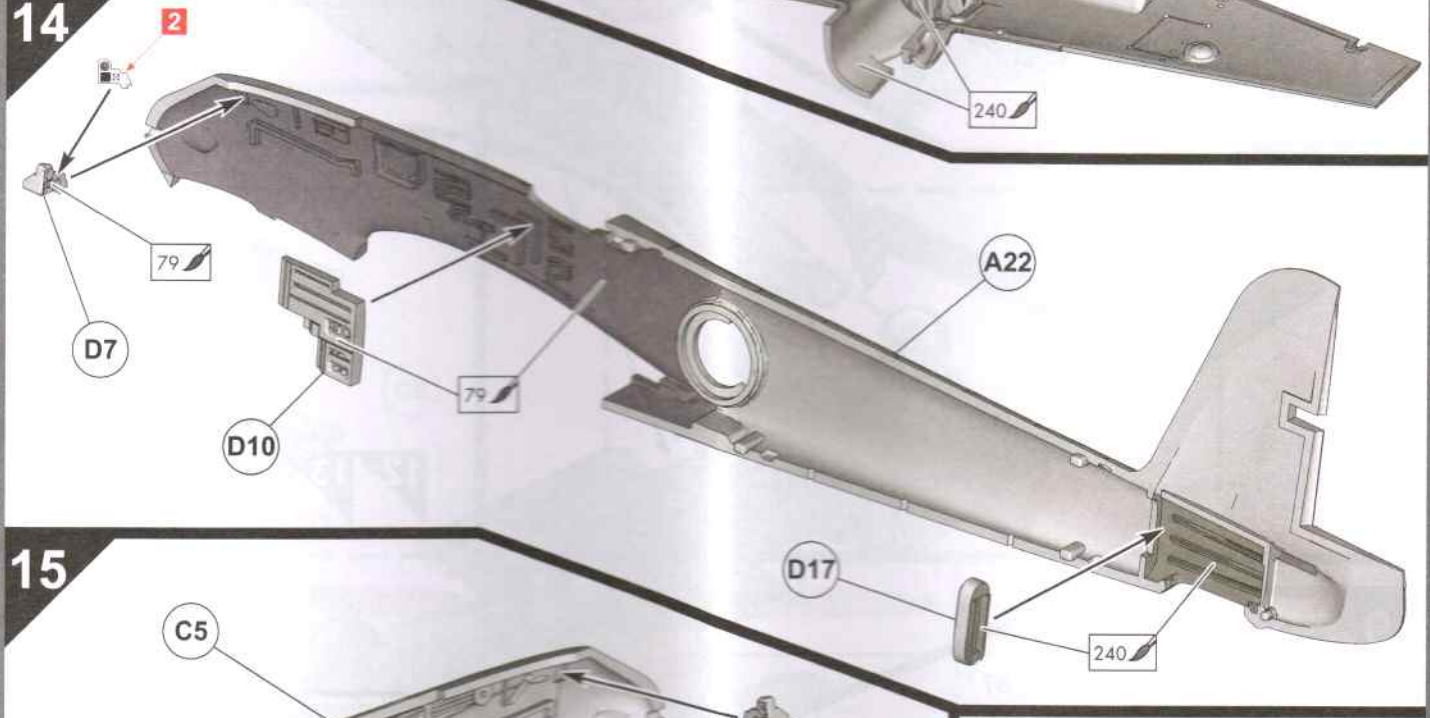

15

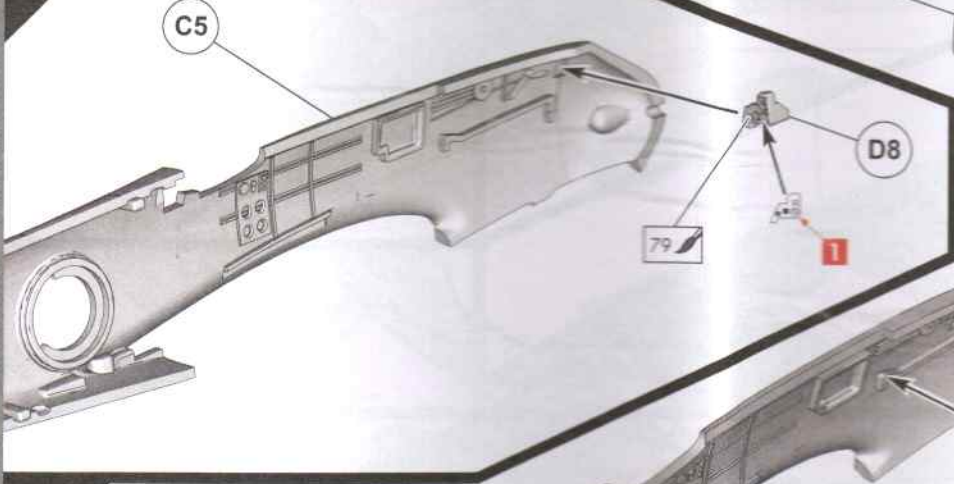

16

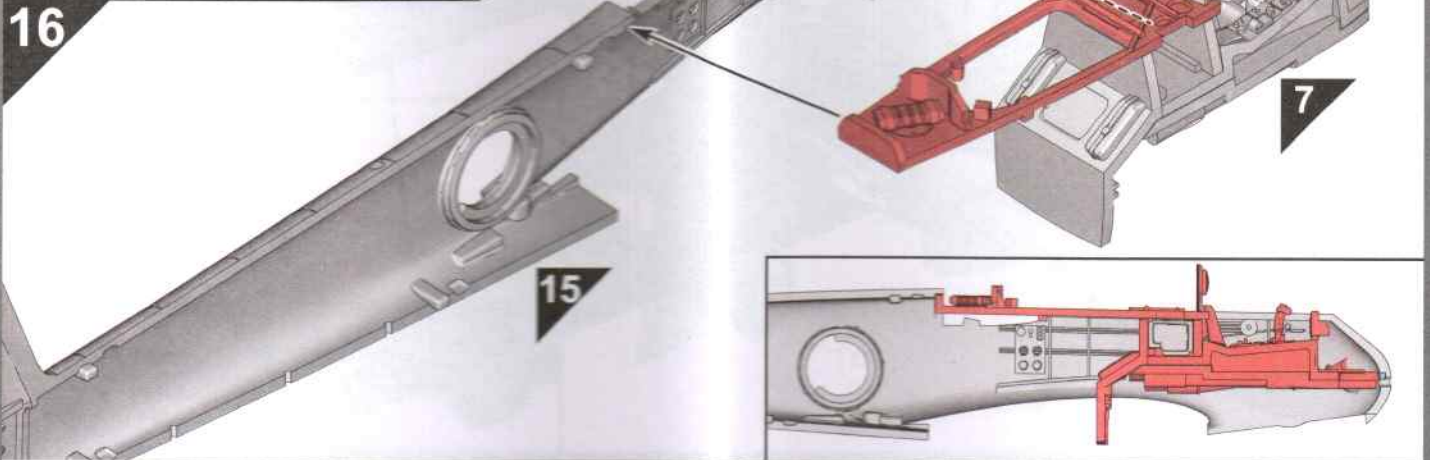

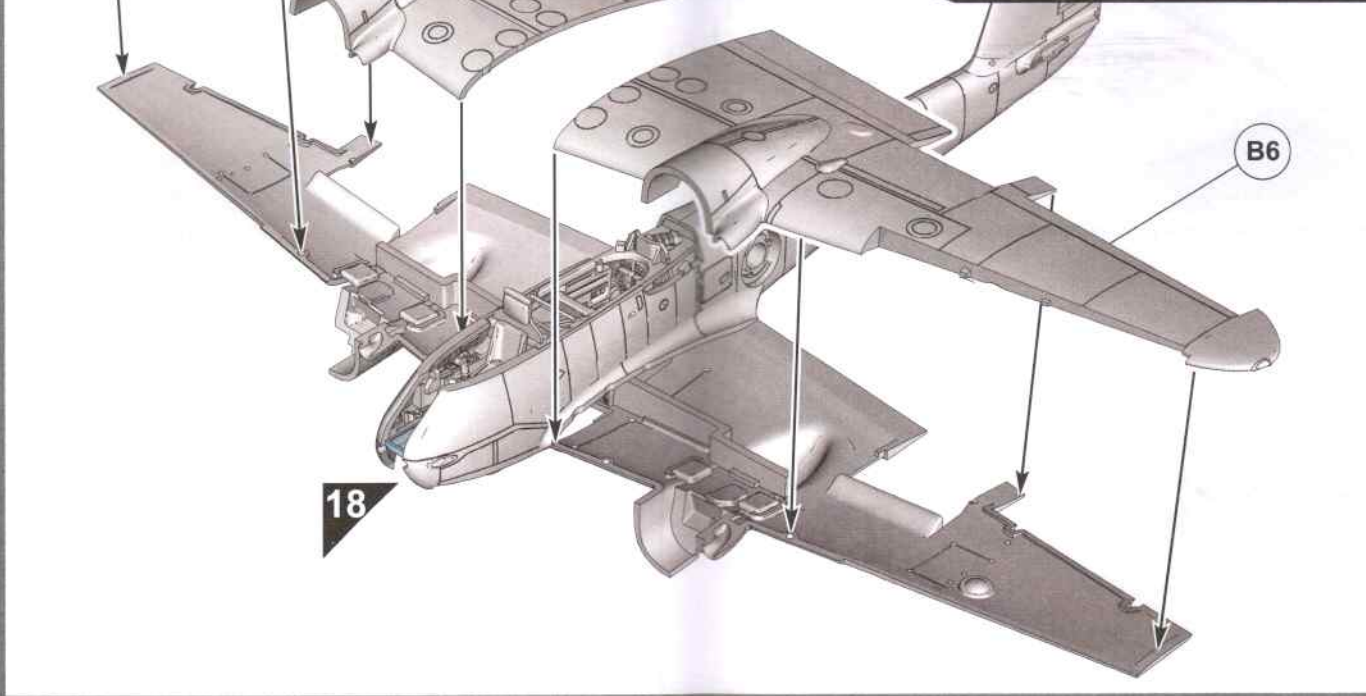
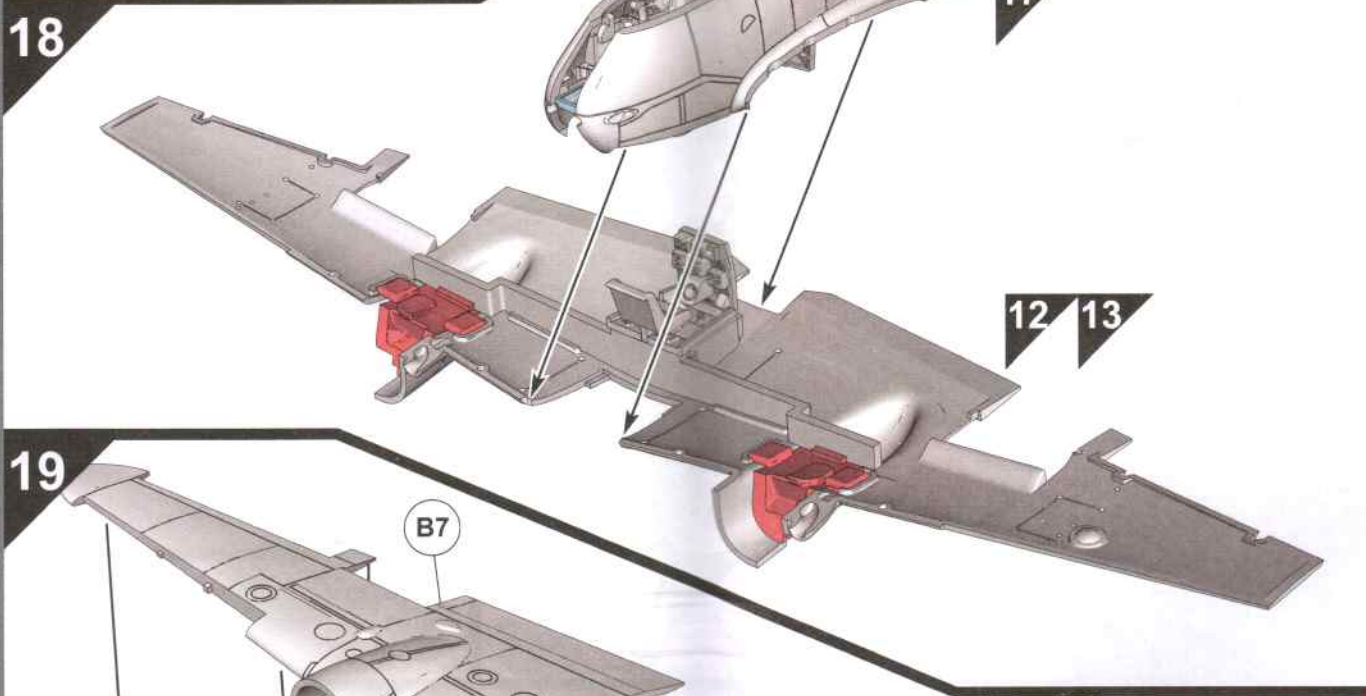
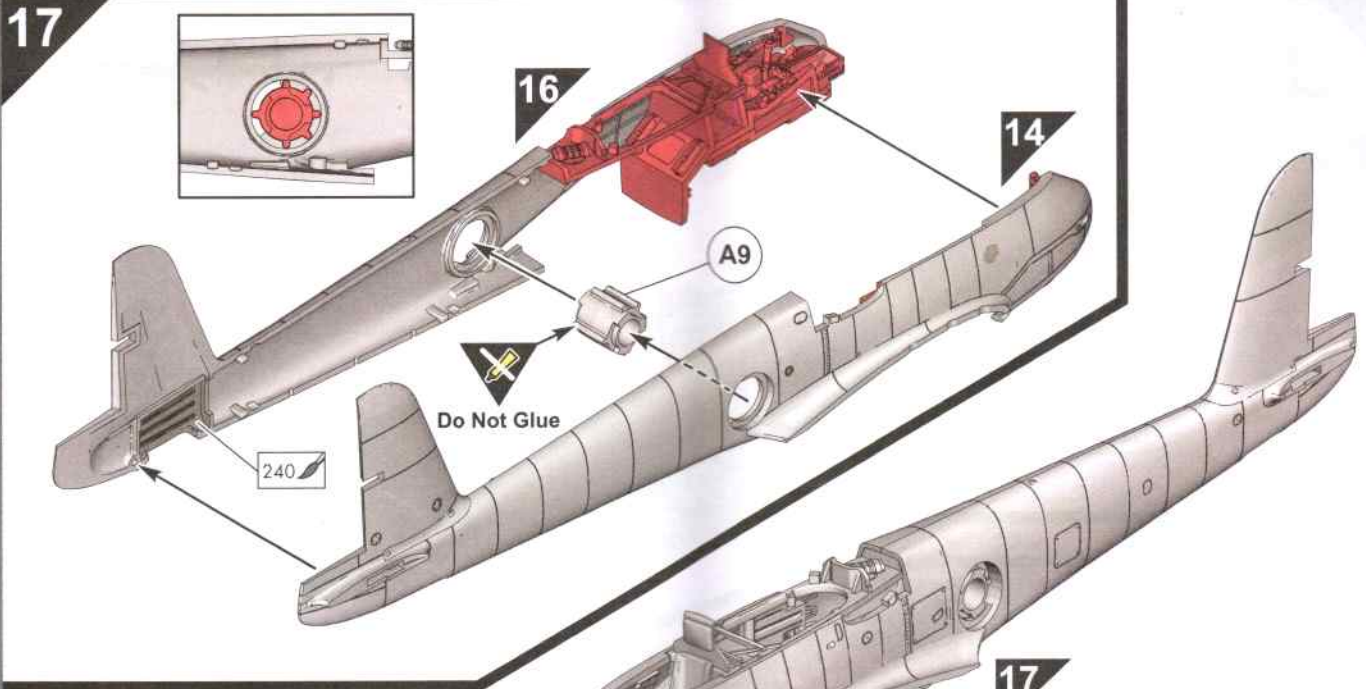

20

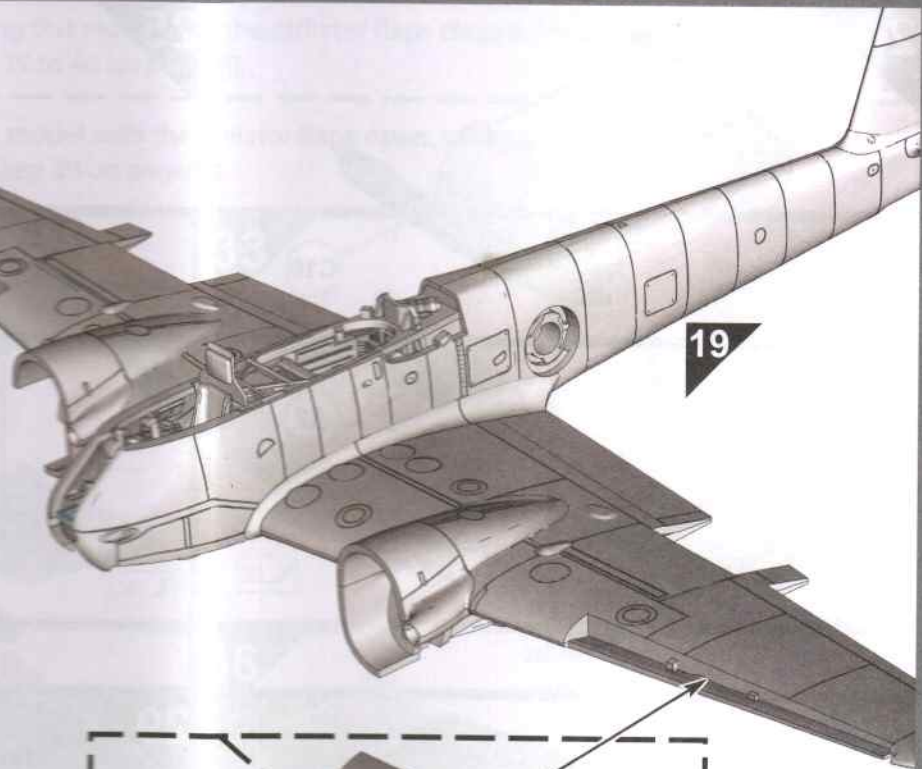
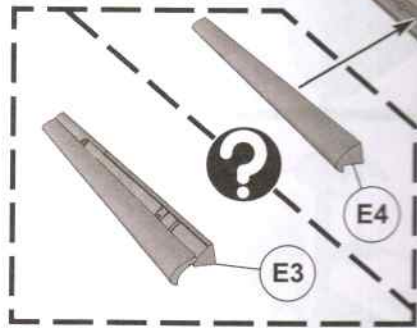

21

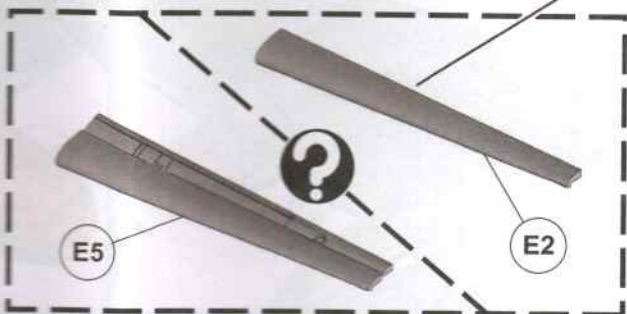
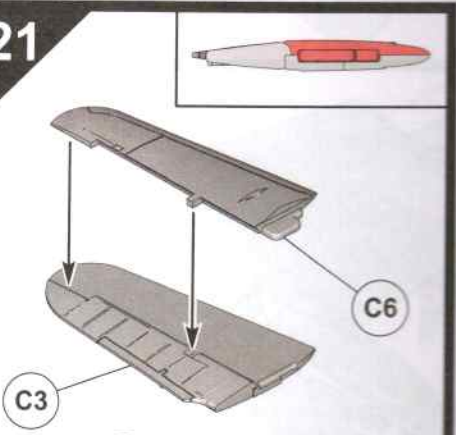

?

22

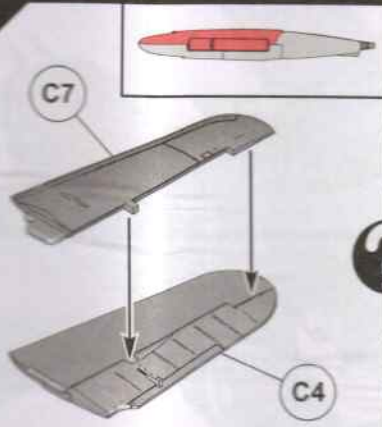
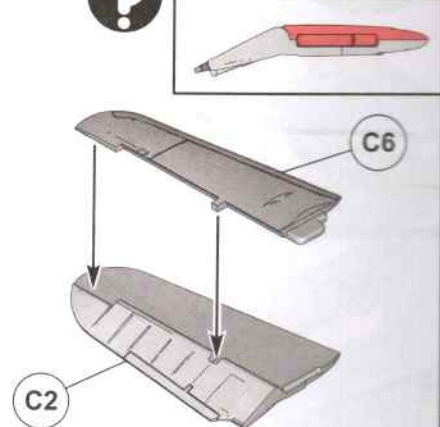

?

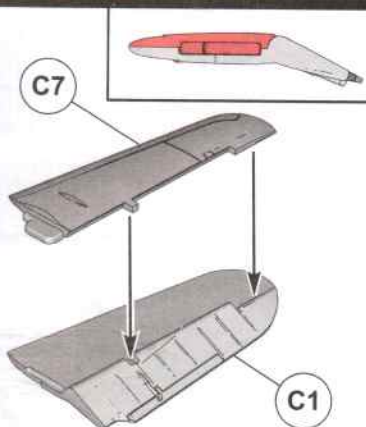

23

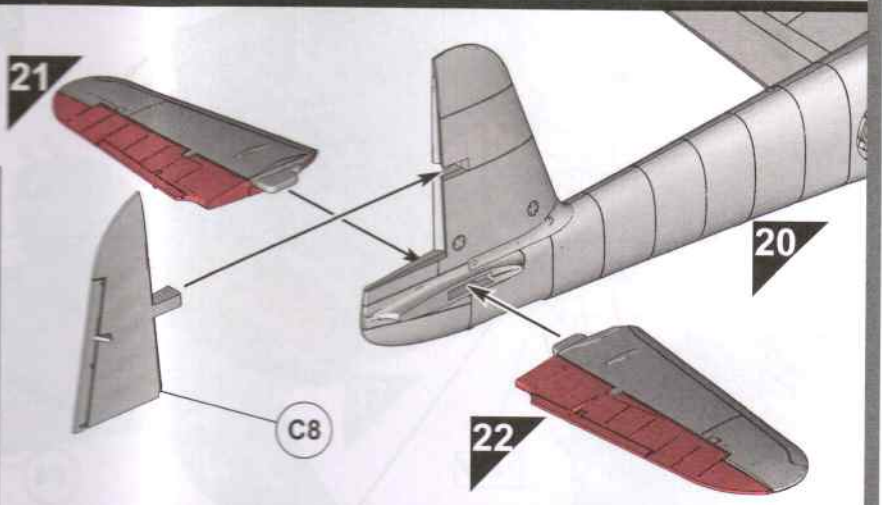

24

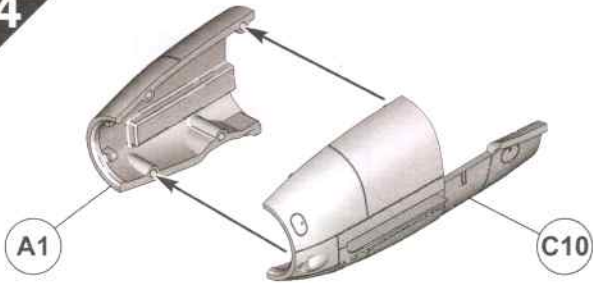

25

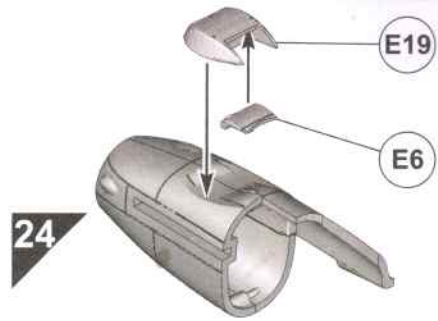

26

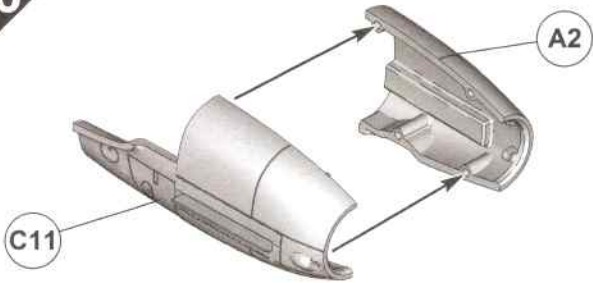

27

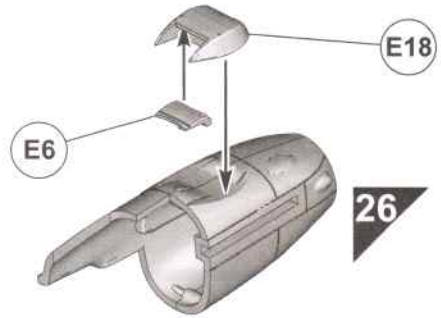

28

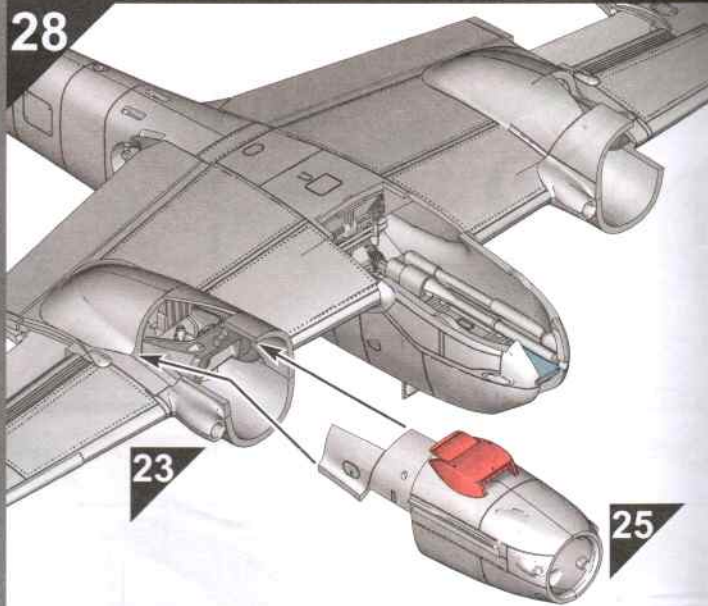

29

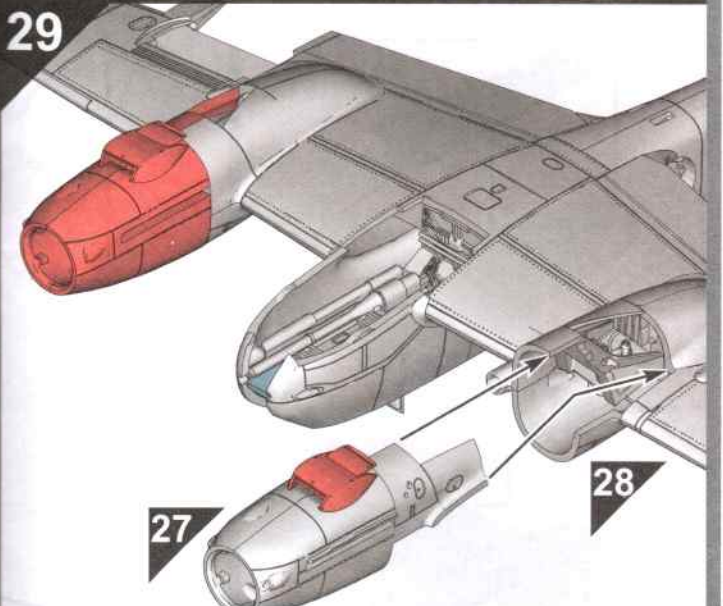

30

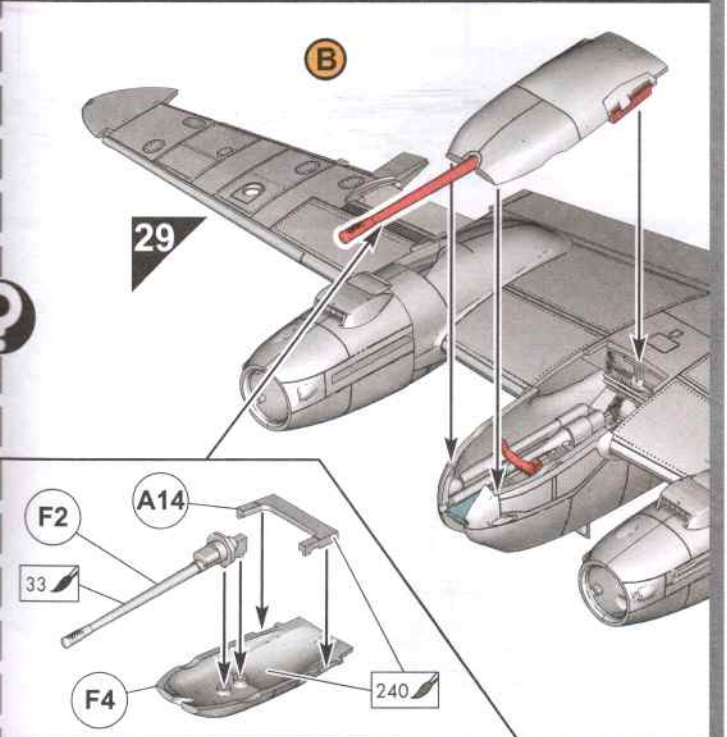
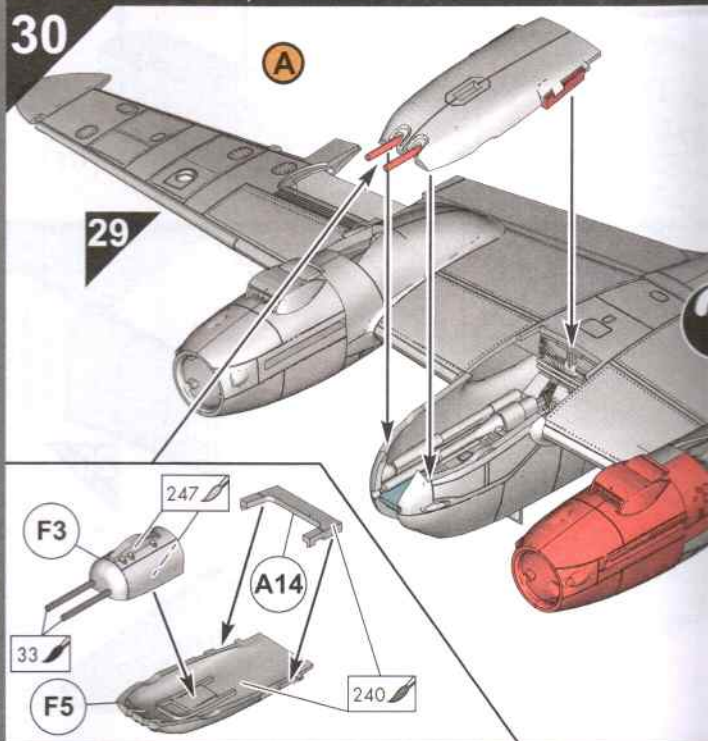



Note: When building this model with the radiator flaps **closed**, follow steps 31 to 38 on page 9 and miss out steps 39 to 46 on page 10.

When building this model with the radiator flaps **open**, miss out steps 31 to 38 on page 9 and carry on from step 39 on page 10.

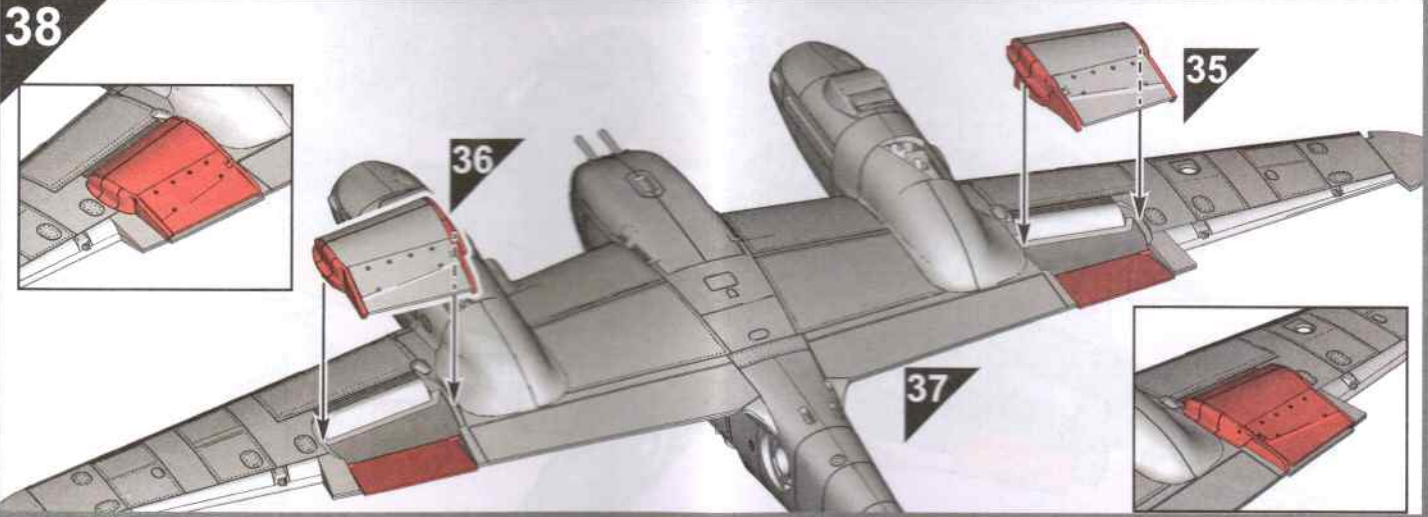
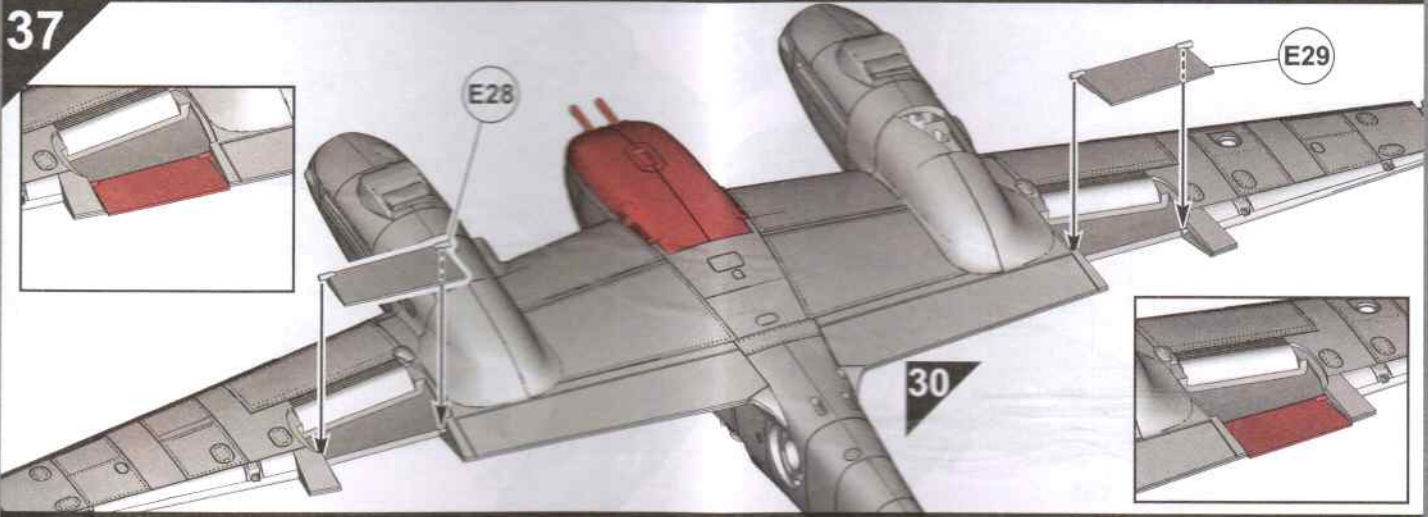
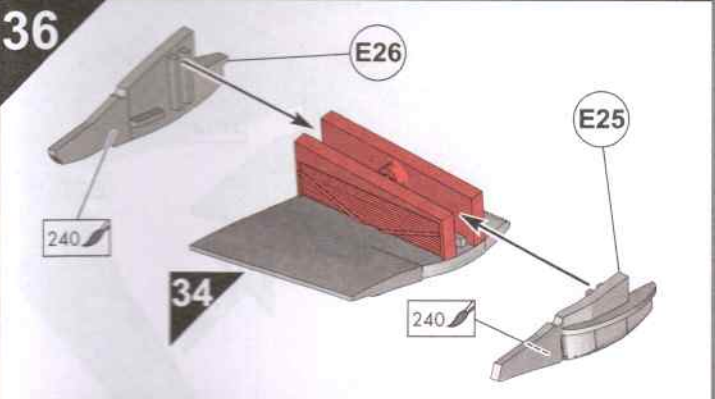
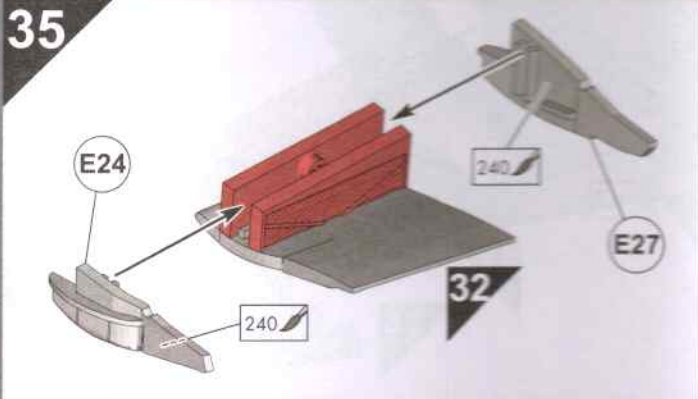
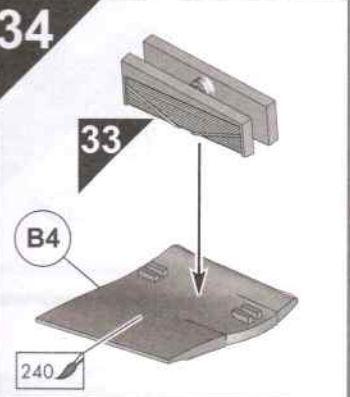
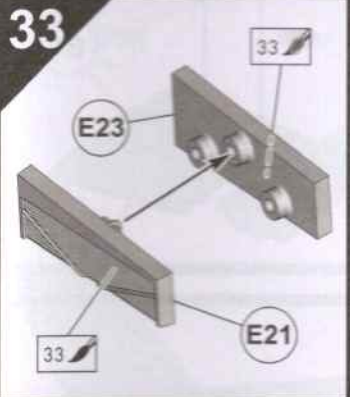
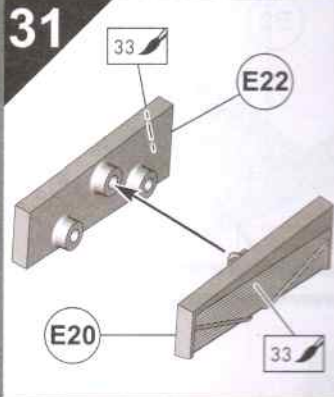

39

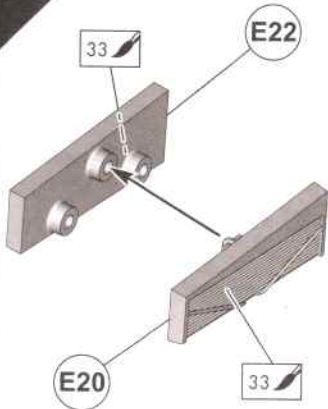

40

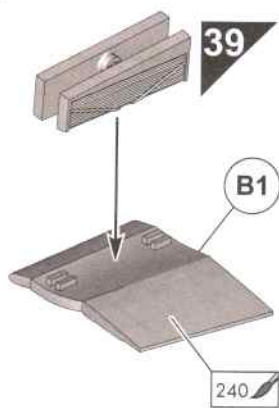

41

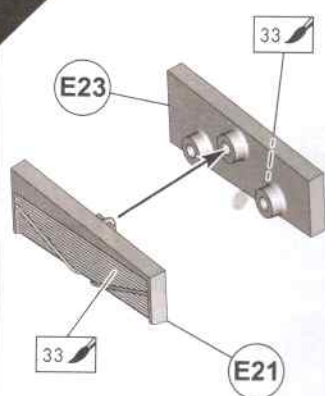

42

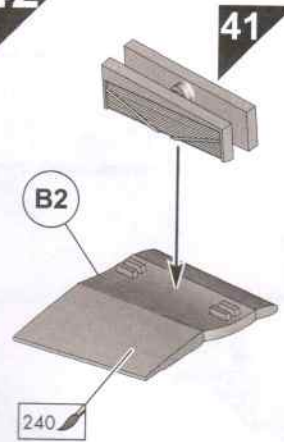

43

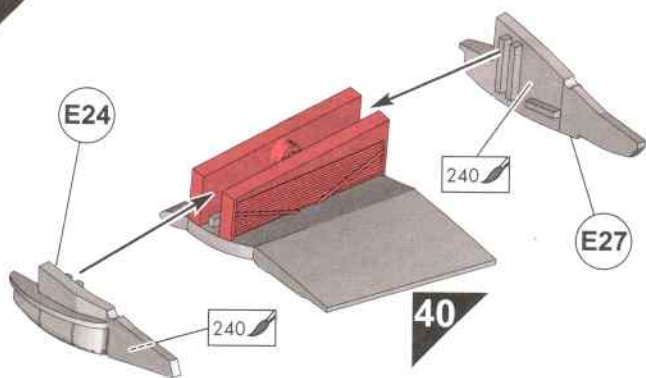

44

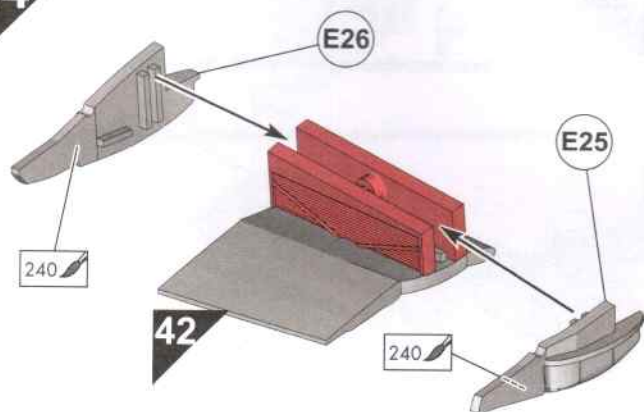

45

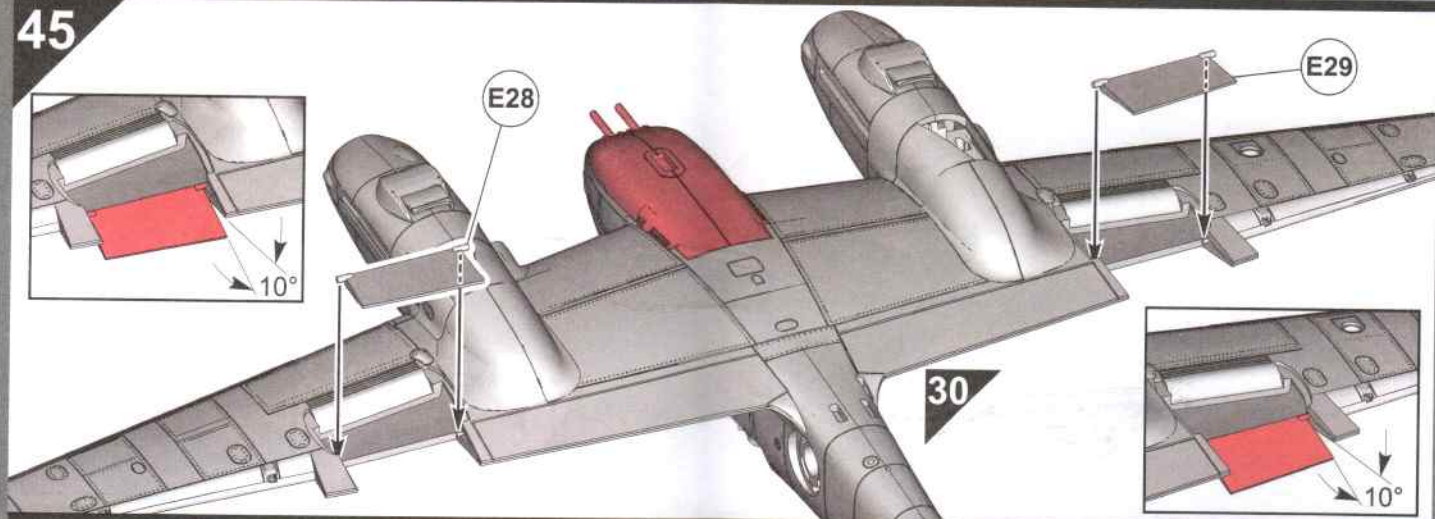

46

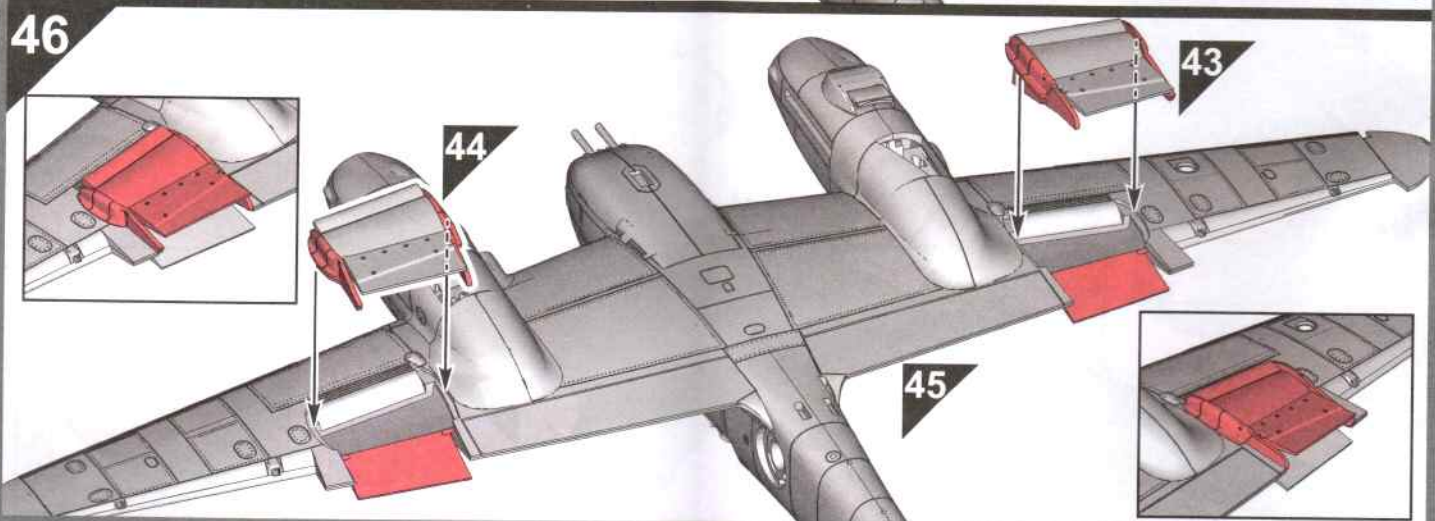

47

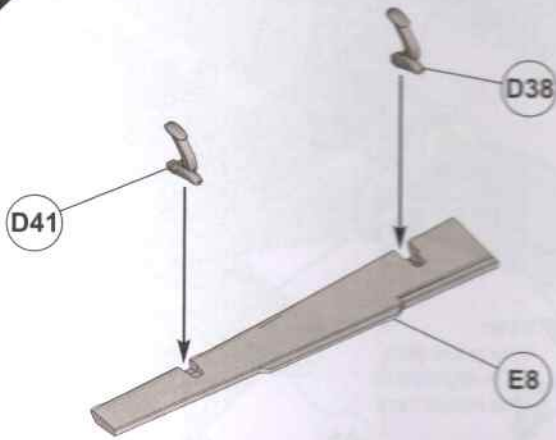

48

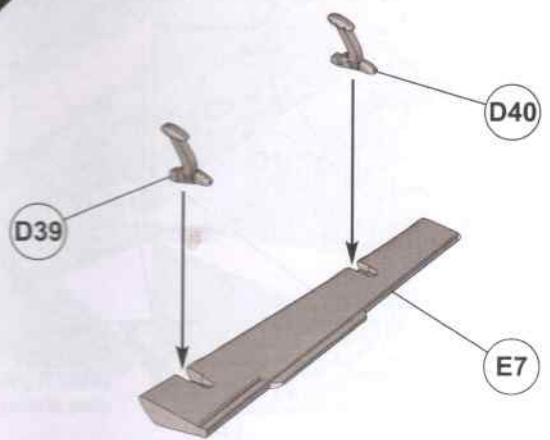

49

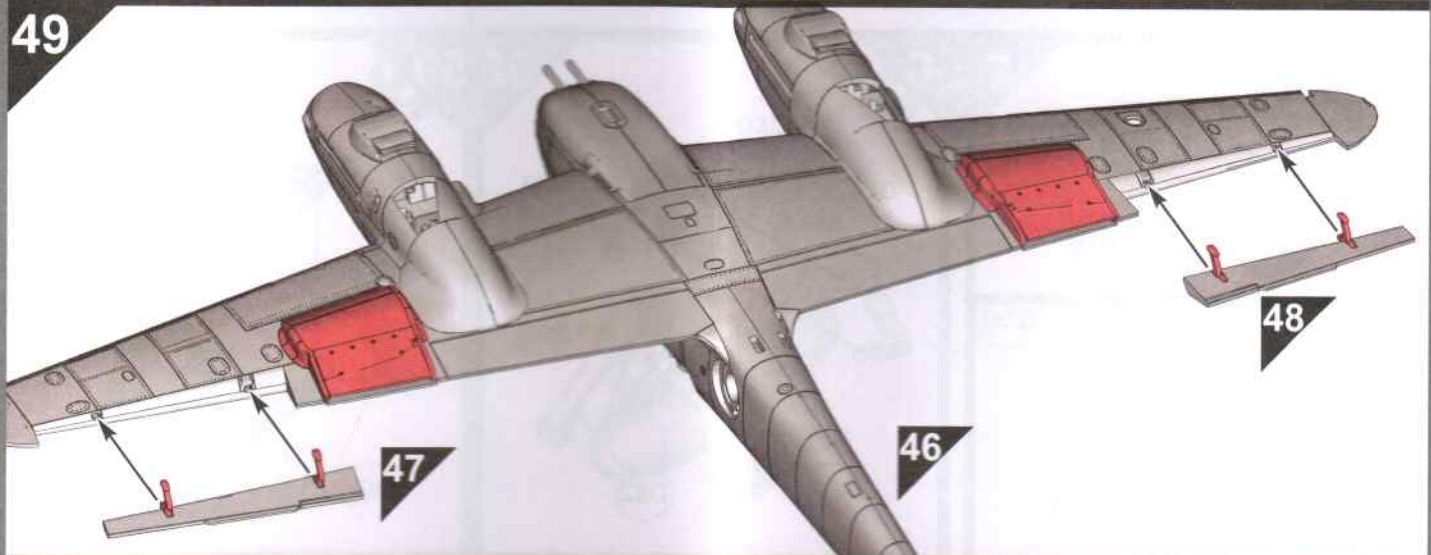

50

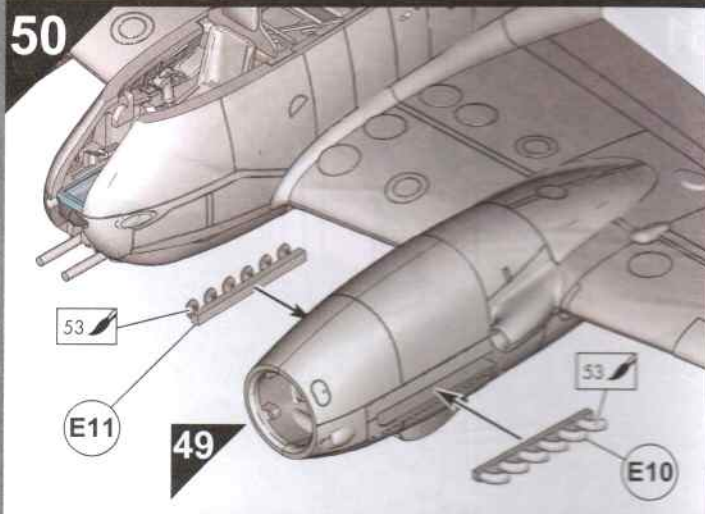

51

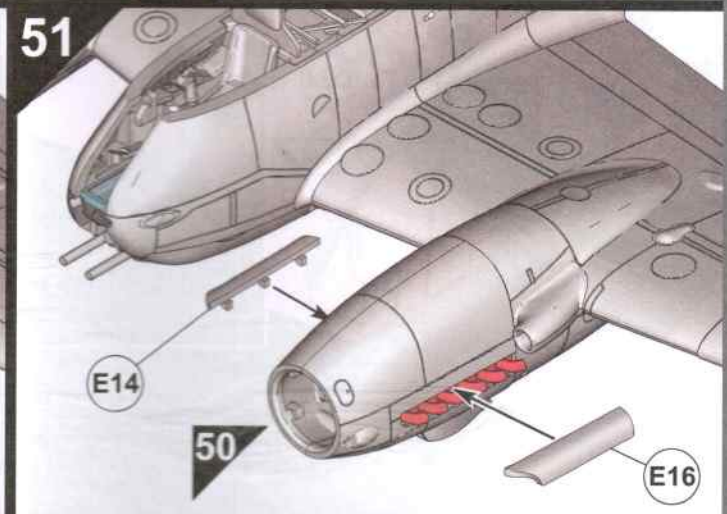

52

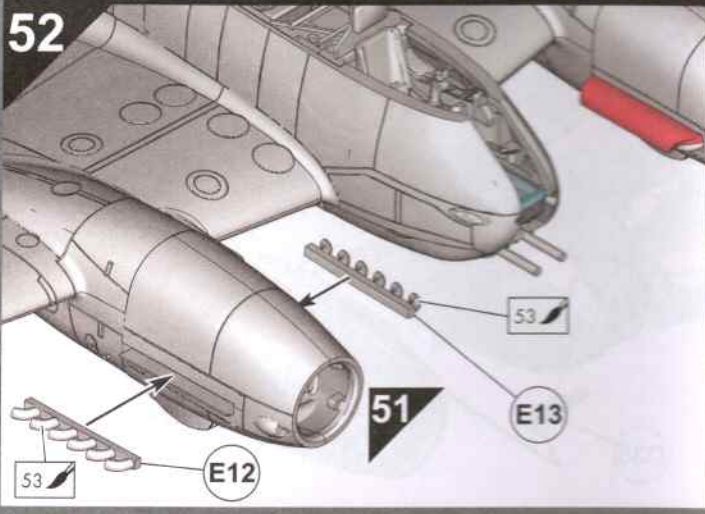

53

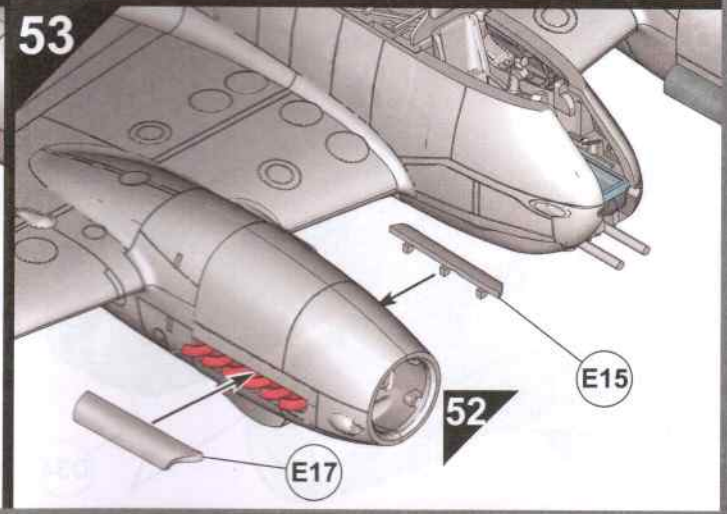

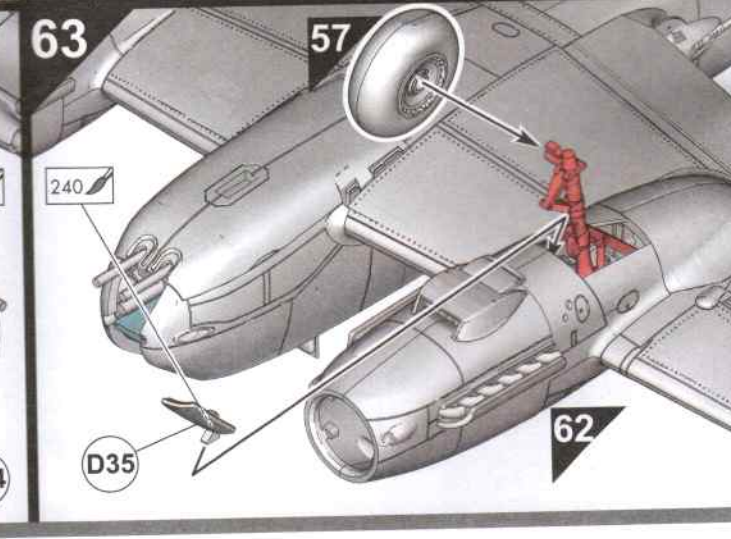
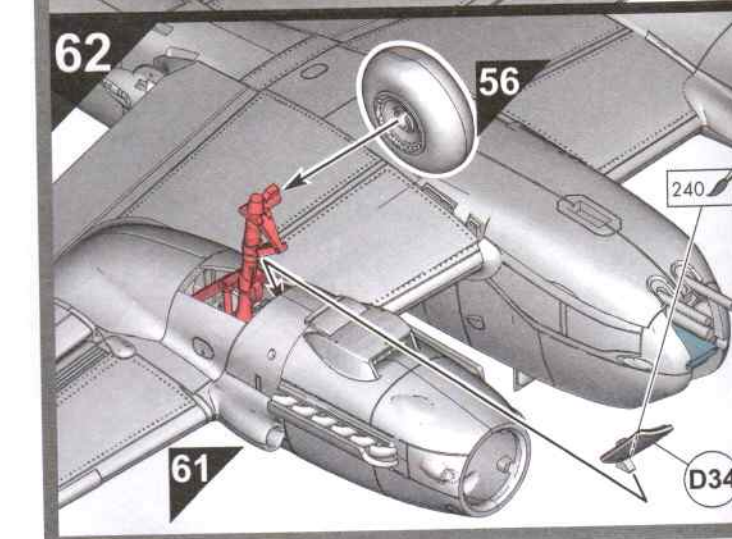
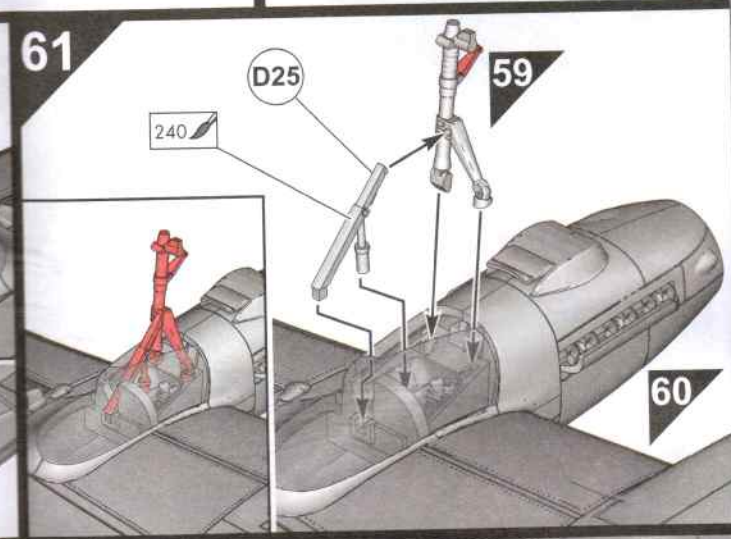
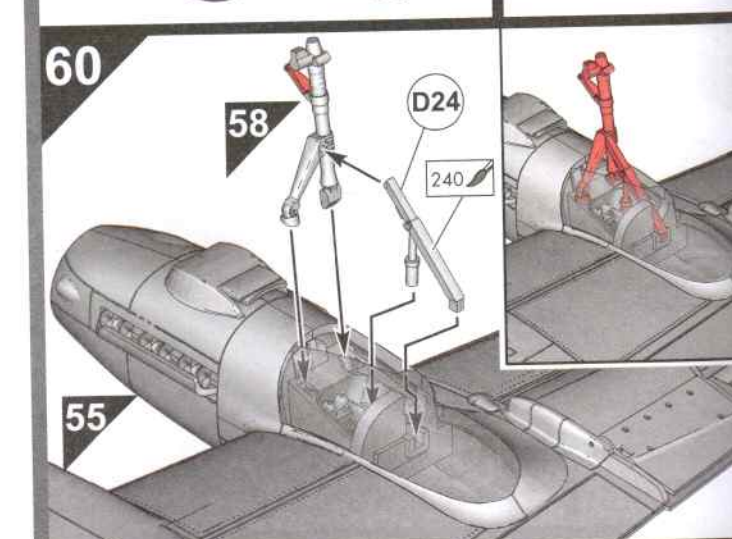
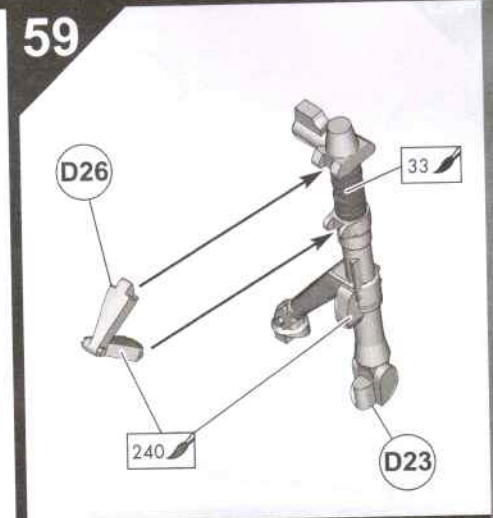
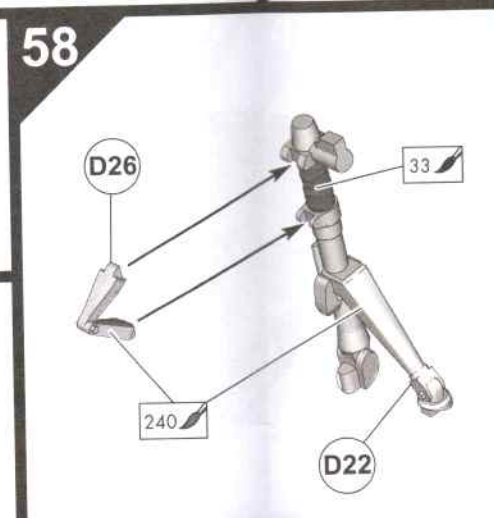
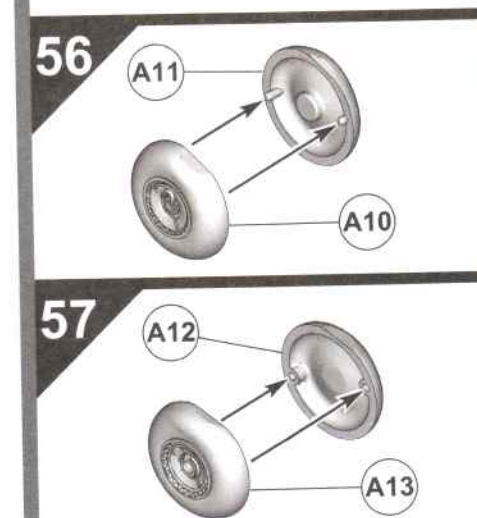
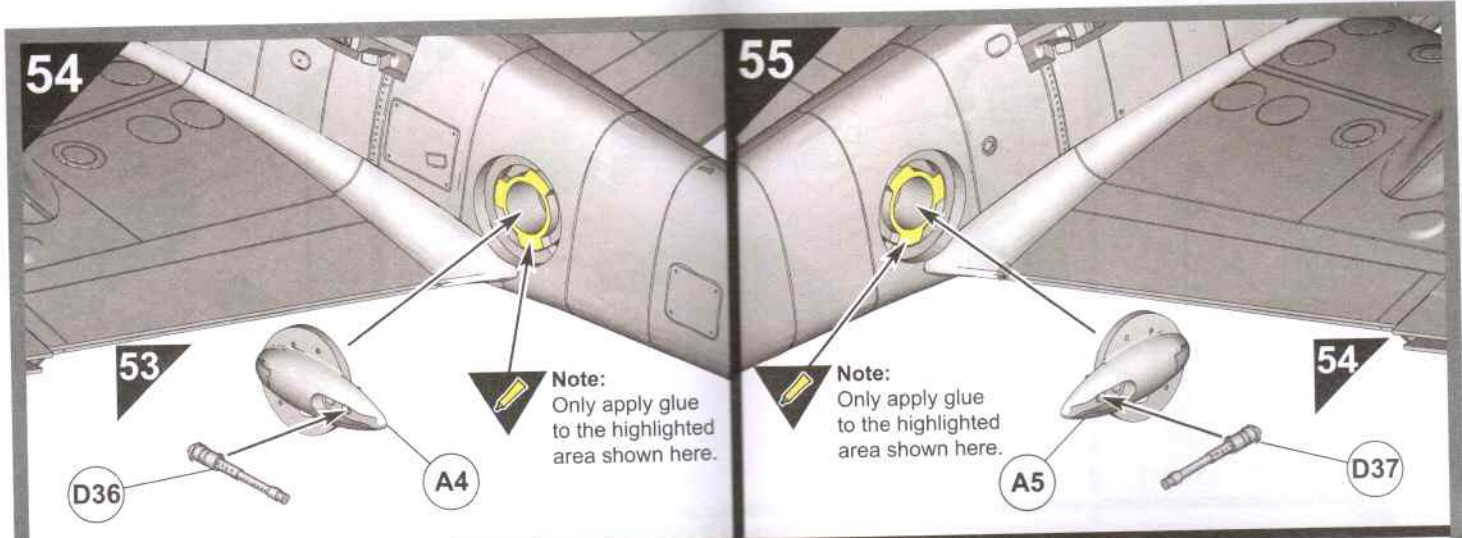

64

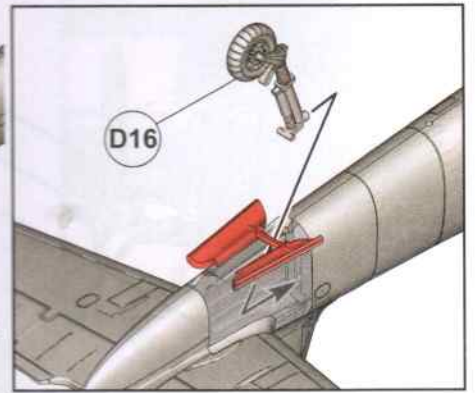
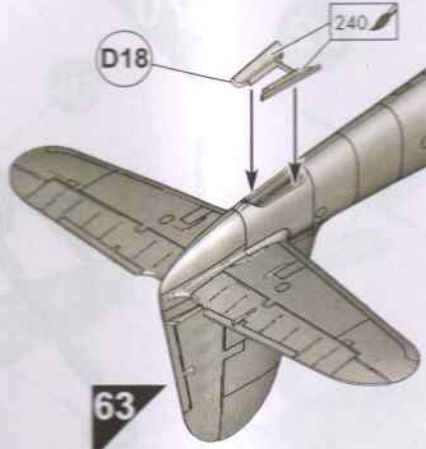
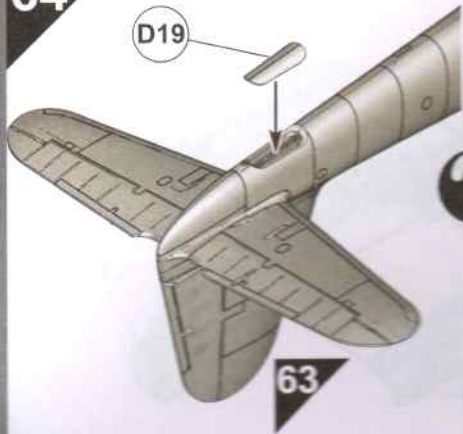

65

x2

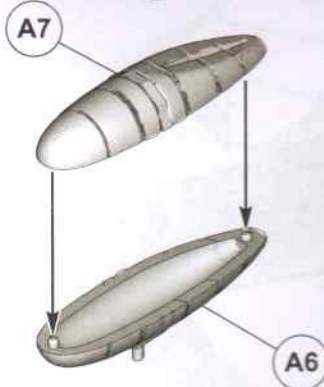

66

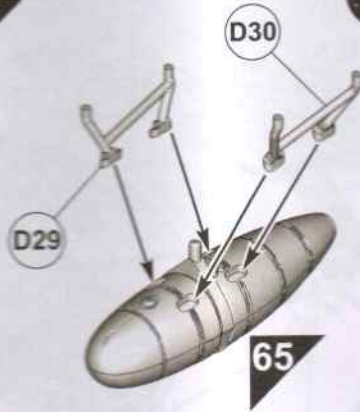

67

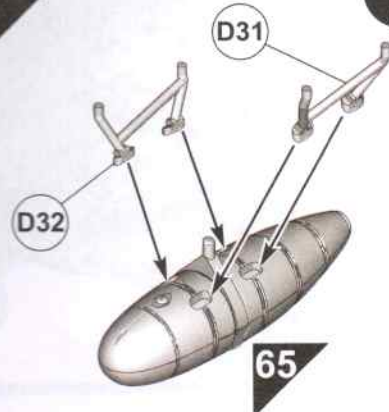

68

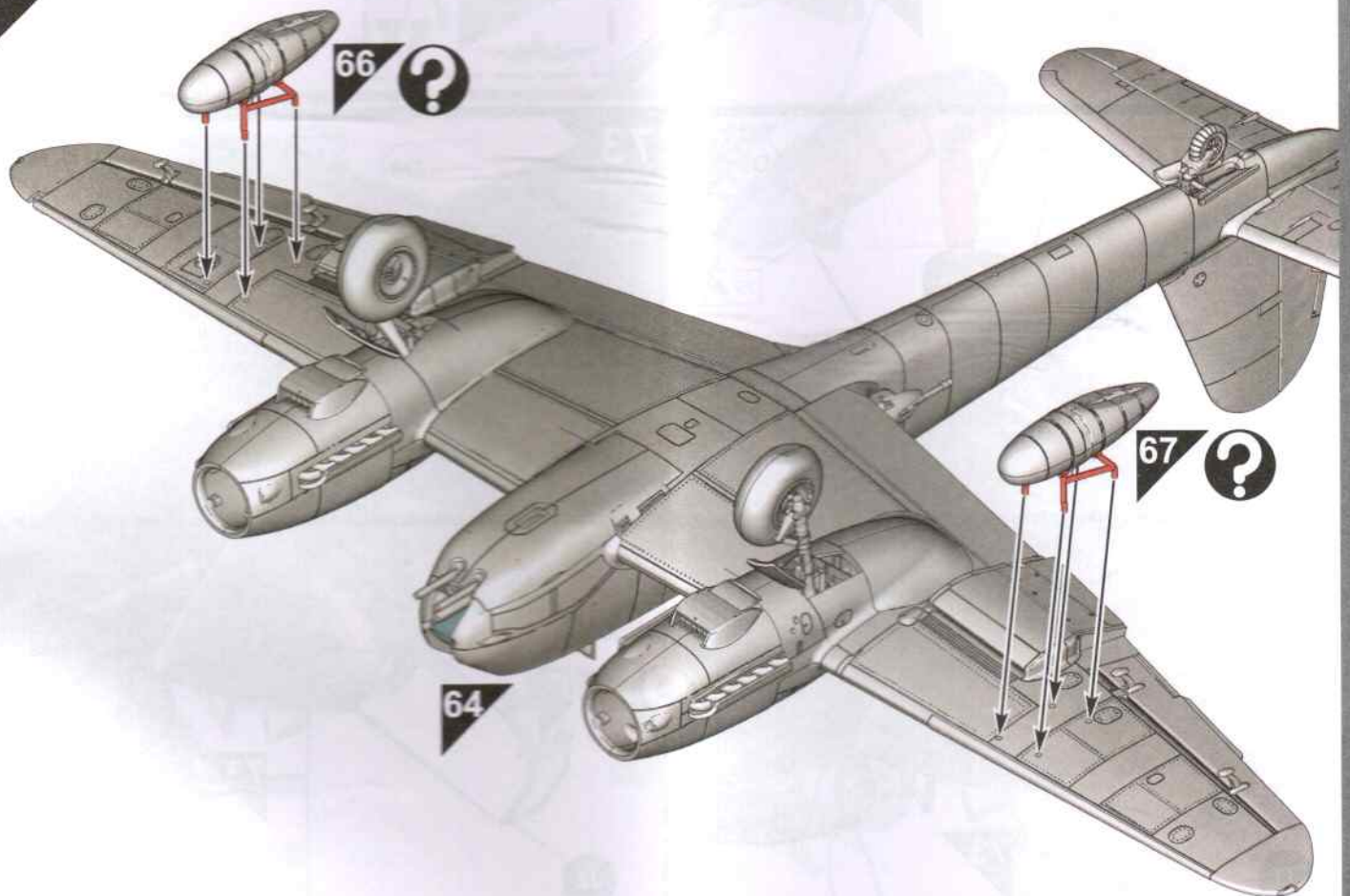

69

x2

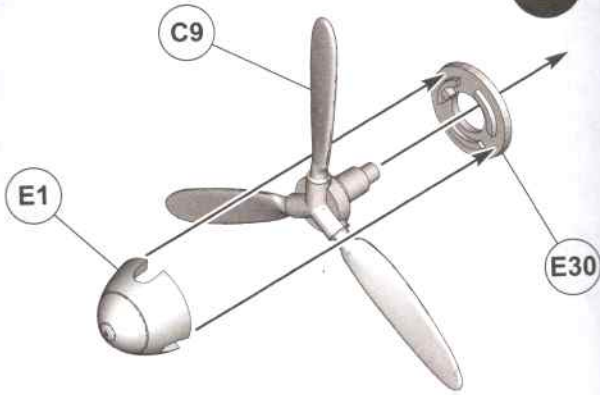

70

x2

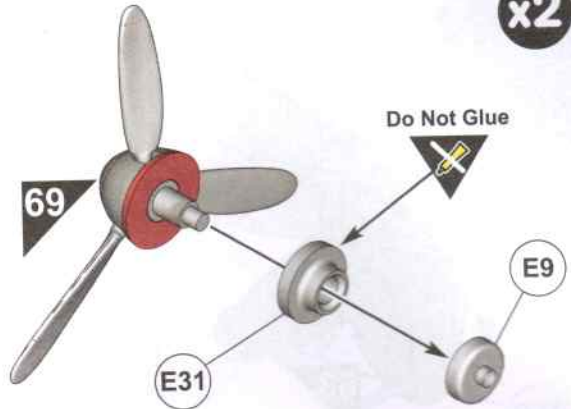

71

68

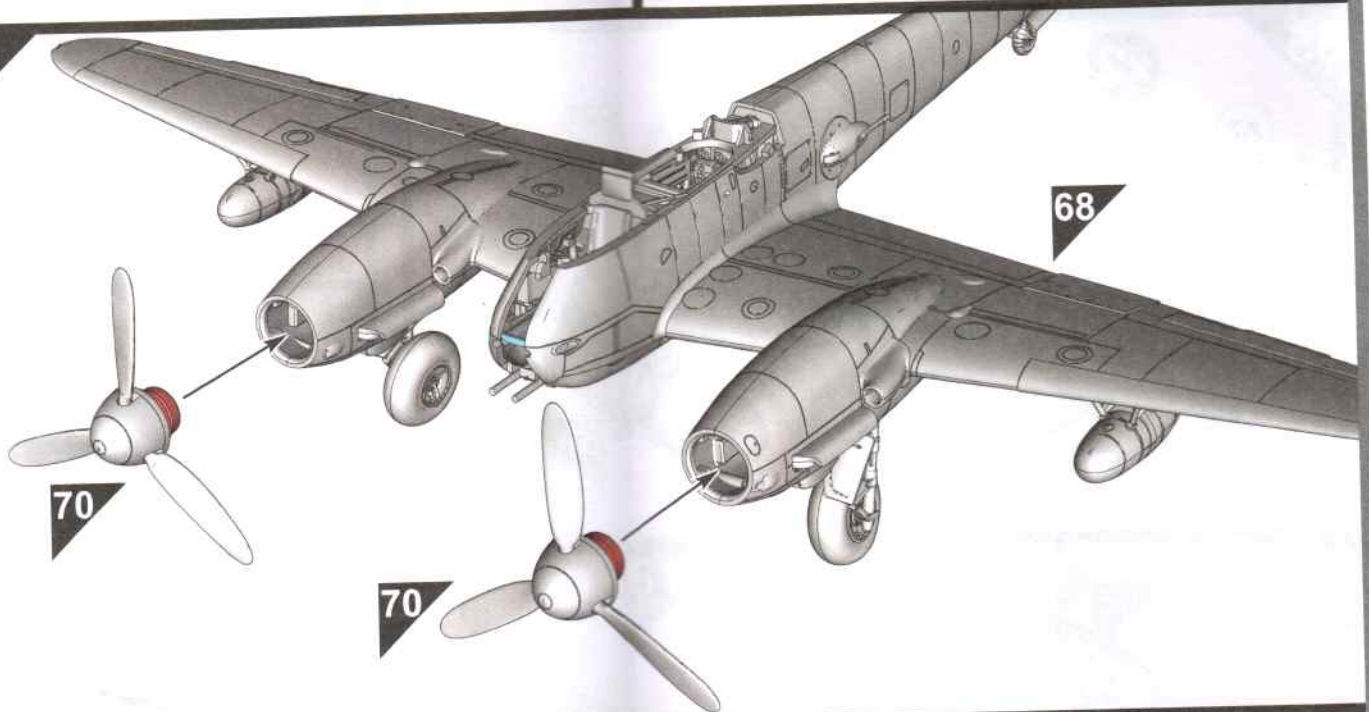

72

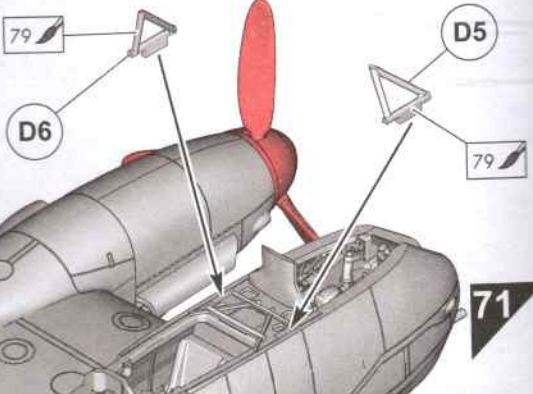

73

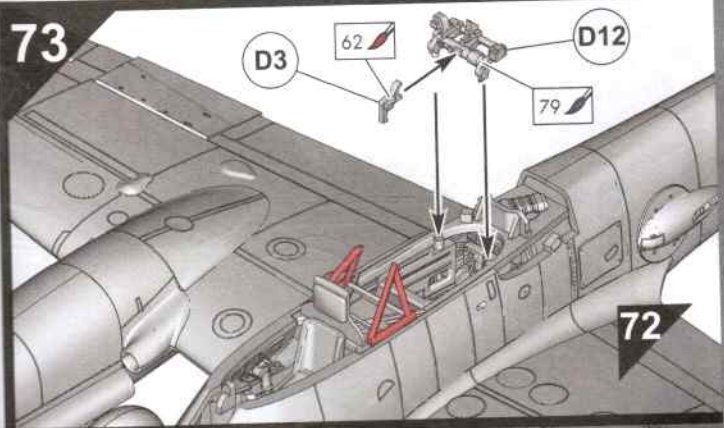

74

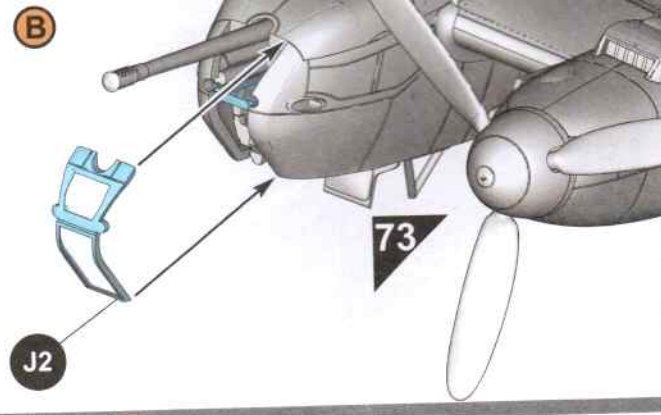
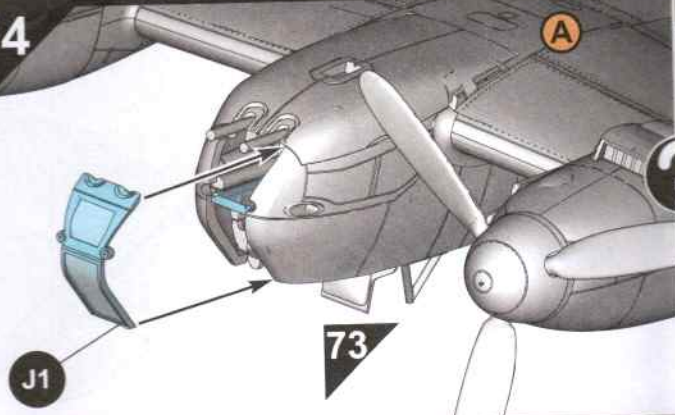

75

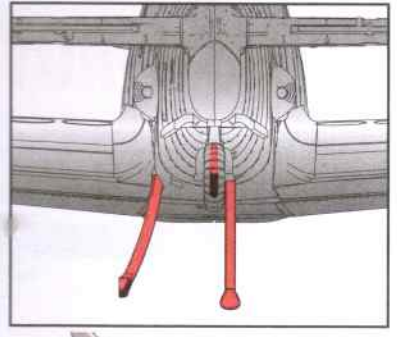
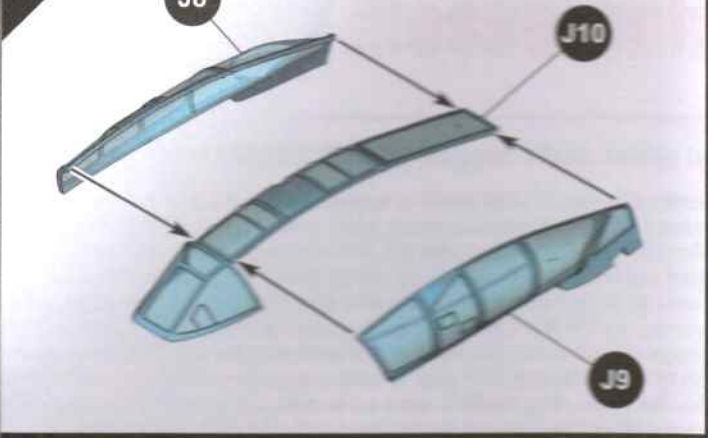

76

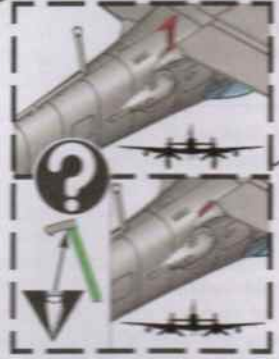
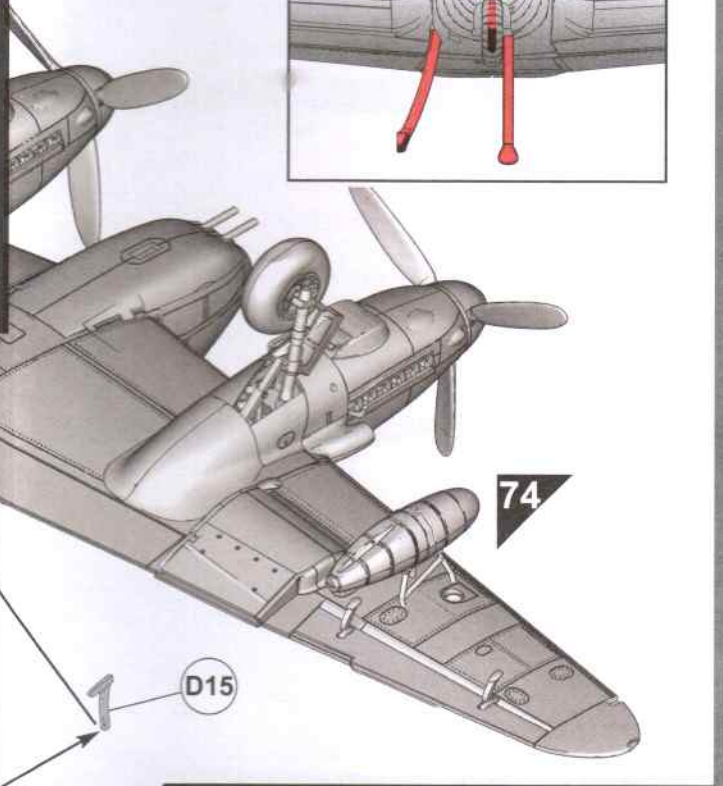
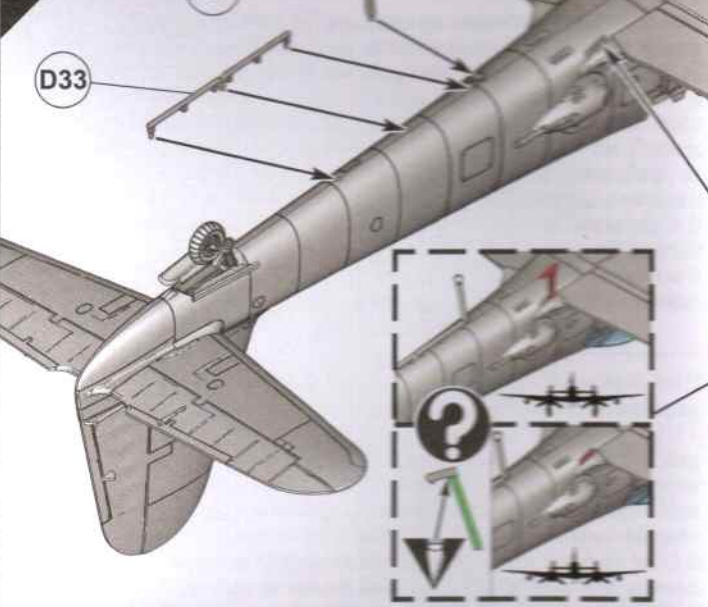

77

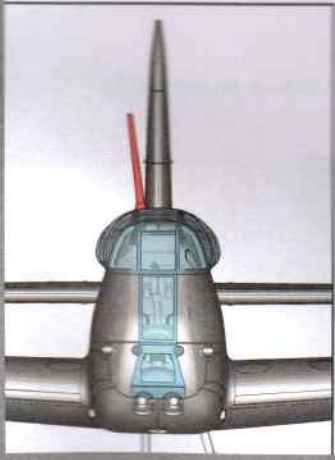
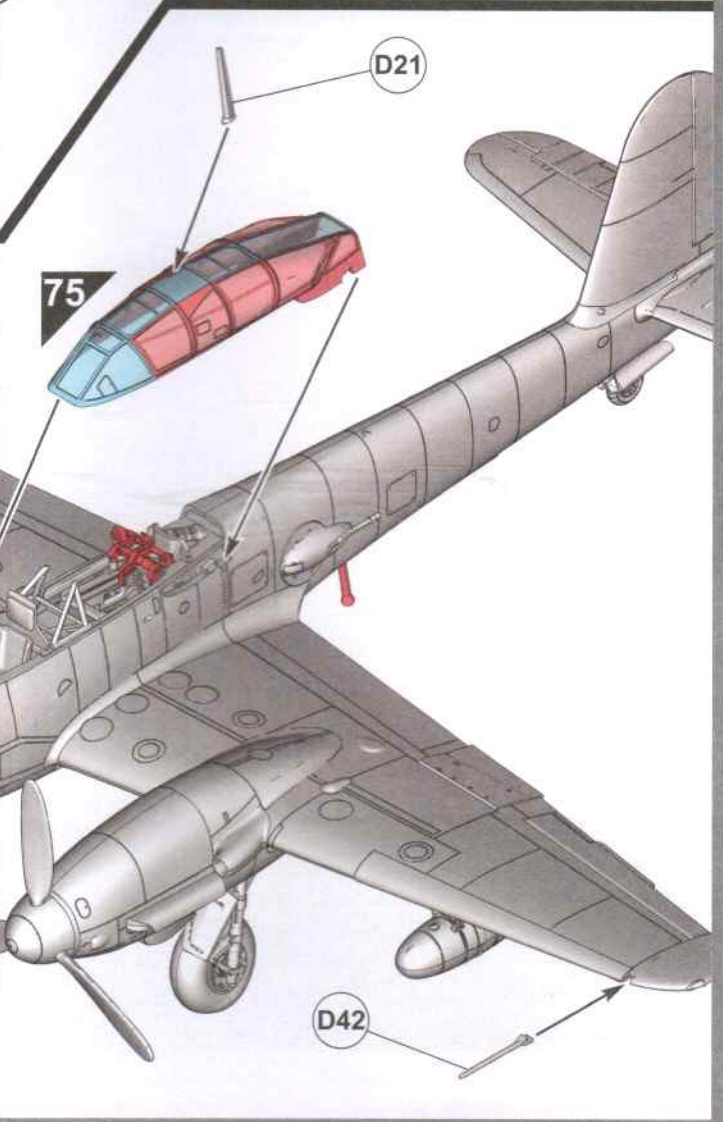
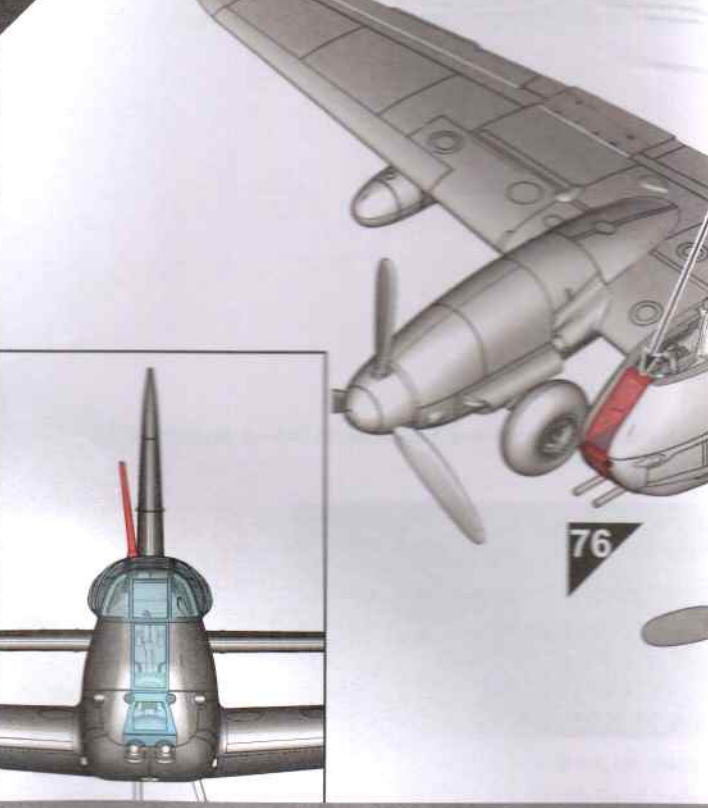

A Messerschmitt Me410A-1/U2

11./Zerstörergeschwader 26, Gardermoen, Norway, 1945

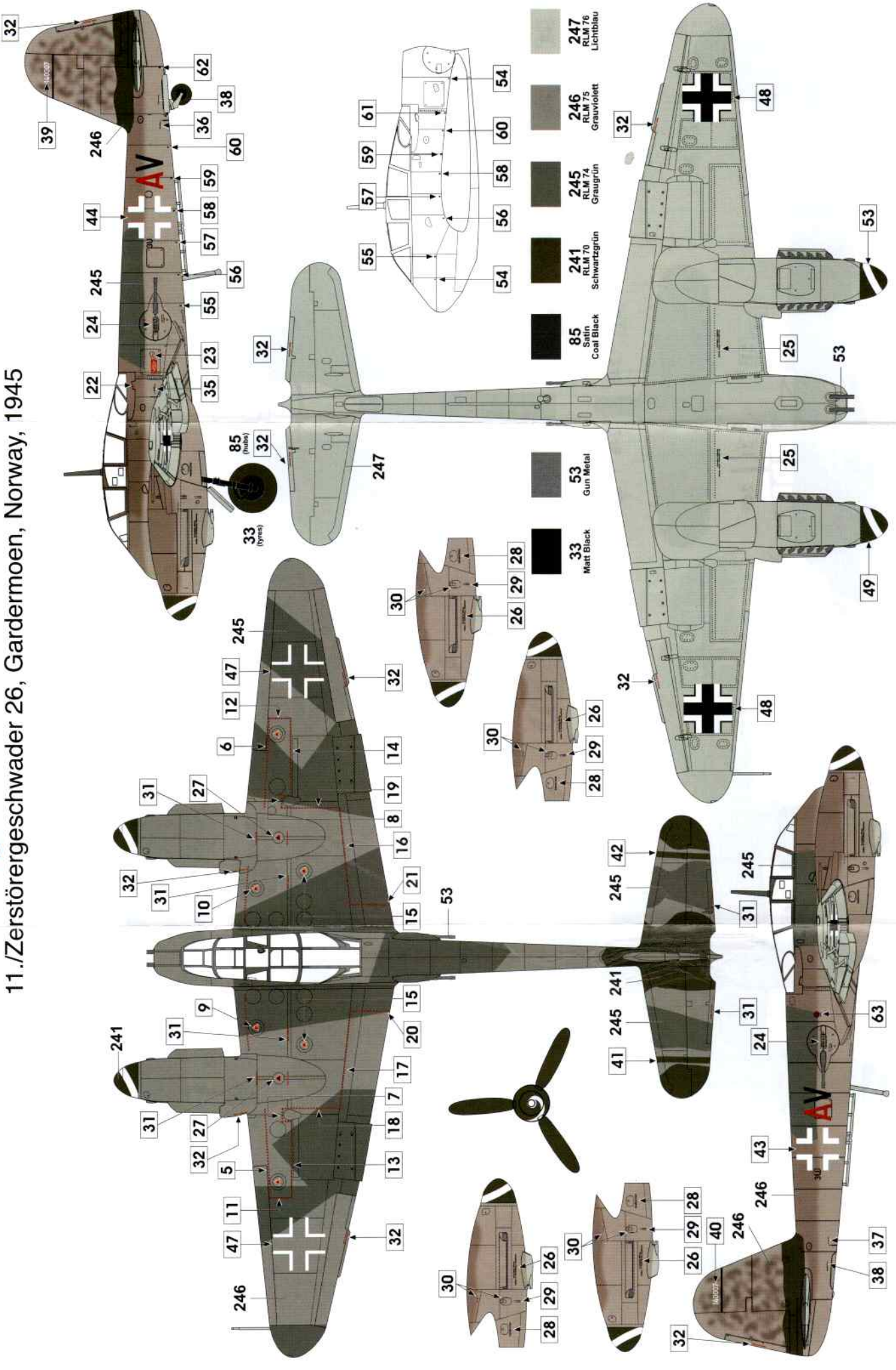

B Messerschmitt Me410A-1/U4

Stab II./Zerstörergeschwader 26, Königsberg, 1944.

