



# 1:72 Consolidated B-24H Liberator

A09010 SCALE MODEL CONSTRUCTION KIT | Wingspan: 465mm Fuselage Length: 298mm | Two Decal Schemes Included

**EN** The second of America's great four engine heavy bombers of the Second World War, the Consolidated B-24 Liberator actually began its development following an Army Air Corps approach for the company to build B-17 Flying Fortresses. Unimpressed at the prospect, Consolidated proposed that they could design and produce their own bomber in the same time it would take them to establish production lines, one which would be better than a Flying Fortress.

When their XB-24 prototype took to the air on 29th December 1939, it was a very different looking aeroplane to the B-17 Flying Fortress, with its shoulder mounted thin wings, deep, yet narrow fuselage and twin-boom tail, it actually had something of a maritime aircraft appearance about it. Following its eventual USAAF introduction in 1941, the B-24 Liberator would go on to be produced in vast quantities, serving in every theatre of war during WWII, and making a vital contribution to the Allied War effort.

The introduction of the 'H' model addressed the aircraft's vulnerability to frontal attack, something enemy fighter pilots had been exploiting since the B-24's introduction. This variant was the first to be manufactured complete with an electrically operated Emerson A-15 nose turret, but also introduced around 50 other modifications to make the Liberator a more combat effective aircraft. This was also the first variant to truly take advantage of America's

capacity for mass production and it was claimed that Ford could produce Liberators faster than the USAAF could process them into service.

The Consolidated B-24 Liberator would become the most heavily produced four engine bomber in the history of warfare and America's most produced aircraft of WWII. Quite simply, the B-24 was flown by more men, carried more bombs over greater distances and destroyed more targets than any other bomber in the history of aviation.

### Specification

Maximum Speed: 290 mph (467km/h)

Range: 1,540 miles (2,480 km) maximum fuel & bomb load

Wingspan: 110 ft 0 in (33.53m)

Length: 67 ft 3.0 in (20.5 m)

Armament: Ten .50 calibre machine guns in four turrets and 2 waist gunner positions

**FR** Deuxième des grands bombardiers lourds quadrimoteurs américains de la Seconde Guerre mondiale, le Consolidated B-24 Liberator a en fait commencé à être développé à la suite d'une demande de l'Army Air Corps à la société Consolidated de construire des B-17 Flying Fortress. Peu impressionnée par cette perspective, Consolidated a proposé de concevoir et de produire son propre bombardier dans le même laps de temps que celui nécessaire à la mise en place des lignes de production — un bombardier qui serait plus performant que les B17 Flying Fortress.

Lorsque son prototype XB-24 a pris l'air le 29 décembre 1939, il s'agissait d'un avion très différent du B-17 Flying Fortress. Avec ses ailes fines montées en haut du fuselage, son fuselage profond mais étroit et sa queue à double dérive, il avait en fait un peu l'apparence d'un avion maritime. Après son introduction dans l'USAAF en 1941, le B-24 Liberator a été produit en très nombreux exemplaires et a servi sur tous les théâtres opérationnels pendant la Seconde Guerre mondiale, apportant une contribution essentielle à l'effort de guerre des Alliés.

L'introduction du modèle H a permis de remédier à la vulnérabilité de l'avion aux attaques frontales, un défaut que les pilotes de chasse ennemis ne cessaient d'exploiter depuis l'introduction du B-24. Cette version a été la première à être fabriquée avec une tourelle de nez Emerson A-15 à commande électrique, mais elle a également reçu une cinquantaine d'autres modifications pour faire du Liberator un avion plus efficace au combat. Il s'agit également de

la première version à tirer véritablement parti de la capacité de production de masse des États-Unis, et l'on prétend que Ford était capable de produire des Liberator plus rapidement que l'USAAF ne pouvait les mettre en service.

Le Consolidated B-24 Liberator allait devenir le bombardier quadrimoteur le plus fabriqué de l'histoire de la guerre et l'avion américain le plus produit de la Seconde Guerre mondiale. Pour faire simple, aucun autre bombardier de l'histoire de l'aviation n'a été piloté par plus d'hommes, n'a transporté plus de bombes sur de plus grandes distances et n'a détruit plus de cibles.

### Spécification:

Vitesse maximale: 467 km/h

Autonomie: 2.480 avec le maximum de carburant et de chargement de bombes

Envergure: 33,53 m

Longueur: 20,5 m

Armement: dix mitrailleuses de 12,7 mm réparties dans quatre tourelles et deux positions de tir latérales

**DE** Die Consolidated B-24 Liberator ist der zweite der berühmten viermotorigen schweren amerikanischen Bomber des Zweiten Weltkriegs. Sie wurde entwickelt, nachdem das Army Air Corps Consolidated Aircraft gebeten hatte, B-17 Flying Fortresses zu bauen. Consolidated schlug stattdessen die Herstellung eines eigenständig entworfenen Bombers vor. Das Unternehmen versprach rechtzeitige Herstellungsbereitschaft und noch bessere Leistungen als die Flying Fortress (Fliegende Festung).

Als der Prototyp XB-24 am 29. Dezember 1939 zum ersten Mal abhob, war klar, dass dieses Flugzeug gänzlich anders als die B-17 Flying Fortress gestaltet war. Mit ihrer an der Rumpfschulter angebrachten dünnen Tragflächen, ihrem hohen und gleichzeitig schmalen Rumpfpfprofil und einem Doppelseitenleitwerk erinnerte sie optisch an einen Marineflieger. Nach ihrer definitiven Inbetriebnahme durch die USAAF im Jahr 1941 wurde die B-24 Liberator bald in enormen Stückzahlen produziert. Im gesamten restlichen Kriegsverlauf wurde sie auf allen Kriegsschauplätzen eingesetzt und leistete einen entscheidenden Beitrag zur Kriegsführung der Alliierten.

Mit der Einführung des "H" Modells wurde die Anfälligkeit des Flugzeugs für Frontalangriffe behoben, ein Umstand, den sich feindliche Jagdpiloten seit der Einführung der B-24 zunutze gemacht hatten. Bei dieser Variante wurde zum ersten Mal ein elektrisch betriebener Emerson A-15 Turm in der Rumpfnase eingebaut. Mit rund 50 weiteren Anpassungen konnte die Kampfkraft der Liberator weiter erhöht werden. Es war auch die erste Variante, bei der die amerikanischen Kapazitäten für die Massenproduktion wirklich ausgenutzt wurden. Angeblich konnte Ford die

Liberators schneller bauen als sie von der USAAF in den Dienst gestellt werden konnten.

Die Consolidated B-24 Liberator wurde schließlich der meistproduzierte viermotorige Bomber in der Kriegsgeschichte und gleichzeitig Amerikas meistgebautes Flugzeug im Zweiten Weltkrieg. Die B-24 wurde von mehr Piloten geflogen, trug mehr Bomben über längere Strecken und vernichtete mehr Angriffsziele als jeder andere Bomber in der Luftfahrtgeschichte.

### Spezifikation:

Höchstgeschwindigkeit: 467 km/h

Reichweite: 2480 km mit maximaler Kraftstoff- und Bombenlast

Spannweite: 33,53 m

Länge: 20,5 m

Waffen: zehn 12,7 mm Maschinengewehre in vier Türmen und zwei Rumpfschützenpositionen

**Note:** Due to the size and weight of the rear fuselage and tail surfaces of this model, it requires a large amount of weight to be added to the forward fuselage to enable the model to rest on its nose wheel. There are two places where we recommend this is added (see Steps 11 and 14 on page 3) and the weight suggested should be regarded as the minimum that needs to be added to avoid a 'tail-sitter'. Alternatively, if the crew entry door under the rear fuselage is fixed in the open position (see steps 18 and 19 on page 4) then the entry ladder can be fixed to support the tail of the model and keep it resting on its nose wheel (see Step 130 page 15).

Airfix would like to thank the following individuals/organisations for their help with the development of this model:

Alan Griffith, Robert Livingstone, Pavel Türk, Gary Fowkes, Andy Davies, RAF Museum, B-24 Liberator Memorial Australia

### FOR BEST RESULTS:

Surfaces to be painted should be clean — before parts are removed from the sprue, wash in warm, soapy water, rinse and dry thoroughly. Stir paints thoroughly before use.

### PLEASE NOTE:

Some parts in the kit may not be required to build the model specified.

**HORNBY  
HOBBIES**



Manufactured by: Hornby Hobbies Ltd Westwood, Margate, Kent, CT9 4JX, UK +44(0)1843 233525 customerservices.uk@hornby.com

EU Authorised Representative: Hornby Italia SRL Viale dei Caduti, 52/A6, Castel Mella (BS), Italy, 25030 +39 0687501292 customerservices.it@hornby.com

**ES** El Consolidated B-24 Liberator, el segundo de los grandes bombarderos pesados cuatrimotores estadounidenses de la Segunda Guerra Mundial, comenzó su desarrollo cuando el Cuerpo Aéreo del Ejército propuso a la compañía la construcción de las Fortalezas Volantes B-17 Flying Fortresses. Consolidated nada impresionada por la propuesta sugirió la creación de su propio bombardero en el mismo periodo requerido para establecer las líneas de producción de los B-17, con la promesa de que superaría a la Fortaleza Volante.

Cuando el 29 de diciembre de 1939 el prototipo XB-24 alzó el vuelo, tenía un aspecto muy diferente al del B-17 Flying Fortress. Con sus delgadas alas montadas en la parte superior, su fuselaje profundo pero estrecho y su cola de doble botolón más bien se asemejaba a una aeronave marítima. Tras su introducción en la Fuerza Aérea del Ejército de Estados Unidos en 1941, el B-24 Liberator se fabricó en grandes cantidades, y desempeñó un papel fundamental en todos los teatros de operaciones durante la Segunda Guerra Mundial, contribuyendo de forma crucial al esfuerzo bélico de los Aliados.

La llegada del modelo "H" abordó la vulnerabilidad del avión a los ataques frontales, un aspecto que los pilotos de caza enemigos habían estado aprovechando desde que se introdujo el B-24. Esta versión fue la primera en contar con una torreta de morro eléctrica Emerson A-15, y también se realizaron otras cincuenta modificaciones para mejorar su eficacia en combate. Además, esta fue la primera versión en la que se aprovechó al máximo la capacidad

de producción en masa de Estados Unidos, llegándose a afirmar que Ford podía fabricar Liberators más rápidamente de lo que la USAAF podía ponerlos en servicio.

El Consolidated B-24 Liberator se convertiría en el bombardero cuatrimotor producido en mayor número de la historia de la guerra y en la aeronave estadounidense con mayor producción durante la Segunda Guerra Mundial. En resumen, el B-24 fue pilotado por más tripulantes, transportó mayor número de bombas a distancias más largas y destruyó más objetivos que cualquier otro bombardero en la historia de la aviación.

**Especificación:**

Velocidad máxima: 467 km/h

Radio de acción: Con carga máxima de combustible y bombas: 2480 km

Envergadura: 33,53 m

Longitud: 20,5 m

Armamento: Diez ametralladoras calibre .50 en cuatro torretas y 2 puestos de artillero de flanco

**SV** Consolidated B-24 Liberator var den andra av USA:s stora tunga bombplan med fyra motorer under andra världskriget. Dess kom faktiskt till efter Army Air Corps initiativ att bygga B-17 Flying Fortress-plan. Consolidated var föga imponerade av planerna och föreslog att de skulle utforma och tillverka sitt eget bombplan på samma tid det skulle till dem att etablera produktionskedjan. Ett som skulle bli mycket bättre än Flying Fortress.

När deras XB-24-prototyp lyfte den 29 december 1939 var det ett väldigt annorlunda flygplan jämfört med B-17 Flying Fortress. Dess tunna axelmonterade vingar, djupa men smala flygkropp och dubbel stjärtbjörn gjorde att den nästan såg ut som ett sjöflygplan. Efter att den introducerades i USAAF år 1941 skulle B-24 Liberator komma att tillverkas i stora mängder och tjänstgöra i varje slag under andra världskriget. Detta gjort planet till en avgörande faktor för de allierades insats i kriget.

H-modellens intåg underströk flygplanetets svaghet i en attack framifrån, vilket är något som stridsflygare hade utnyttjat ända sen B-24 togs i drift. Modellen var den första att helt tillverkas med ett eldrivet Emerson A-15-nostorn, men den introducerade omkring 50 andra modifieringar som gör Liberator till ett mer effektivt flygplan. Det här var också den första modellen som verkligen tog vara på USA:s kapacitet för massstillverkning och det påstods

att Ford kunde producera Liberators snabbare än USAAF kunde sätta dem i tjänst. Consolidated B-24 Liberator skulle bli det mest tillverkade bombplanet i krigshistorien och USA:s mest producerade flygplan under andra världskriget. B-24 flögs helt enkelt av fler piloter, flög fler bomber över längre distanser och träffade fler mål än något annat bombplan i flyghistorien.

**Specifikation:**

Maximal hastighet: 467 km/h

Räckvidd: 2 480km med maximalt fyllt bränsle och bombast

Vingspann: 33,53 m

Längd: 20,5 m

Bestyckning: Tio 50-kalibriga maskingevär i fyra torn och två mittskyttspositioner

**ASSEMBLY INSTRUCTIONS**

**EN** Study drawings and practise assembly before cementing parts together. Carefully scrape paint from cementing surfaces. All parts are numbered. Paint small parts before assembly. To apply decals cut sheet as required, dip in warm water for a few seconds, slide off backing into position shown. Use in conjunction with box artwork. Not appropriate for children under 36 months of age, due to the presence of small detachable parts.

**FR** Étudier attentivement les dessins et simuler l'assemblage avant de coller les pièces. Gratter soigneusement toute peinture sur les surfaces à coller. Toutes les pièces sont numérotées. Peindre les petites pièces avant l'assemblage. Pour coller les décalcomanies, découper le motif, le plonger quelques secondes dans de l'eau chaude puis le poser à l'endroit indiqué en décollant le support papier. Utiliser conjointement avec les illustrations sur la boîte. Ne convient pas aux enfants de moins de 36 mois - présence de petits éléments détachables.

**DE** Vor dem Zusammenkleben der Teile die Zeichnungen sorgfältig ansehen und die zu verklebenden Teile zur Vermeidung möglicher Fehler versuchsweise zusammenfügen. Dann an den Klebeflächen vorhandene Farbbeschichtung vor dem Zusammenkleben vorsichtig abkratzen. Alle Bestandteile sind mit Nummern versehen. Kleine Teile vor dem Zusammenbau bemalen. Abziehbilder wie gewünscht ausschneiden. Vor dem Anbringen einige Sekunden in warmes Wasser tauchen und dann vom Trägerpapier in ihre vorgesehene Position schieben. Dabei die Abbildungen auf der Schachtel beachten. Nicht für Kinder unter 36 Monaten geeignet, da abnehmbare bzw. lose angebrachte Kleinteile enthalten sind.

**ES** Estudiar los dibujos y practicar el montaje antes de pegar las piezas. Raspar cuidadosamente la pintura en las superficies de contacto antes de pegar las piezas. Todas las piezas están numeradas. Es conveniente pintar las piezas pequeñas antes de su montaje. Para aplicar las calcomanías, cortarlas de la hoja, sumergirlas en agua tibia durante unos segundos y deslizarlas a la posición indicada. Utilizar en conjunción con la ilustración de la caja. No es adecuado para niños menores de 36 meses, ya que contiene piezas pequeñas que podrían soltarse.

**SV** Studera bilderna noggrant och sätt ihop delarna innan du limmar ihop dem. Skrapa försiktigt bort färg från limmade delar. Alla delarna är numrerade. Måla smådelarna före ihopsättning. Sätt fast dekalerna genom att klippa arket, doppa i varmt vatten några sekunder och låta baksidan glida på plats som bilden visar. Använd enligt bildanvisningarna på kartongen. Rekommenderas ej för barn under 3 år. Innehåller löstagbara smådelar.

**NL** Tekeningen bestuderen en delen in elkaar zetten alvorens deze te lijmen. Lak voorzichtig van lijmvlakken afschrapen. Alle delen zijn genummerd. Kleine delen vóór montage verven. Voor aanbrengen van stickers, gewenste stickers uit het vel knippen, een paar seconden in warm water dompelen en dan van het schutblad af op afgebeelde plaats schuiven. Hierbij afbeelding op doos raadplegen. Niet geschikt voor kinderen onder 3 jaar, omdat kleine deeltjes gemakkelijk kunnen losraken.

**PO** Przed przystąpieniem do sklejania przestudiuj uważnie rysunki i przećwicz składanie części. Ostrożnie zeskrób ze sklejanych powierzchni farbę. Wszystkie części są ponumerowane. Drobnie części pomaluj przed ich złożeniem. Celem przeniesienia kalkomanii wytnij ją z arkusza, zanurz na kilka sekund w letniej wodzie i zsuj z podłoża na wymagane miejsce. Używaj w połączeniu ze wzorami na pudełku. W związku z obecnością wielu drobnych, rozbiernych części, nieodpowiednie dla dzieci poniżej 3 lat.

**IT** Studiare i disegni ed esercitarsi a montare i vari pezzi prima di fissarli con la colla. Raschiare con cura le tracce di vernice dalle superfici da incollare. Tutti i pezzi sono numerati. Verniciare i pezzi di piccole dimensioni prima di montarli. Per applicare le decalcomanie, ritagliare il foglio nel modo richiesto, immergere in acqua calda per alcuni secondi, quindi staccare la decalcomania dalla carta di supporto e posizionarla nel punto desiderato. Usare le decalcomanie come indicato nell'illustrazione riportata sulla confezione. Non adatto a bambini di età inferiore a 36 mesi per la presenza di componenti di piccole dimensioni che potrebbero staccarsi.

**PT** Estudar atentamente os desenhos e experimentar a montagem. Raspar cuidadosamente as superfícies de modo a eliminar pintura antes de colar. Todas as peças estão numeradas. Pintar as pequenas peças antes de colar. Para aplicar as decalcomanias, cortar as folhas e mergulhar em água morna por alguns segundos, depois deslizar e aplicar no respectivo lugar, como indicado nas ilustrações na caixa. Não convém a uma criança de menos de 36 meses devido à presença de pequenos elementos destacáveis.

**EL** Μελετήστε προσεκτικά τα σχέδια και συναρμολογήστε για πρώτη φορά τα κομμάτια χωρίς να τα συγκollήσετε. Αφαιρέστε επιμελώς την πλαστική βαφή από τις επιφάνειες τις οποίες θα συγκollήσετε. Όλα τα κομμάτια είναι αριθμημένα. Χρωματίστε τα μικρά κομμάτια πριν από τη συναρμολόγηση. Για να κολλήσετε τις χαρκομανίες, κόψτε γύρω από το σχέδιο όπως απαιτείται, βυθίστε το μερικά δευτερόλεπτα σε χλιαρό νερό και μετά τοποθετήστε το στη θέση που υποδεικνύεται, αφαιρώντας τη μεμβράνη που το καλύπτει. Λάβετε υπόψη σας ταυτόχρονα την εικονογράφηση του κουπίου. Ακατάλληλο για παιδιά ηλικίας κάτω των 36 μηνών λόγω ύπαρξης μικρών κομματιών που αποσπώνται.

**FI** Tutustu piirroksiin ja harjoittele kokoamista, ennen kuin liimaat osat yhteen. Raaputa maali varovasti pois liimattavilta pinnolta. Kaikki osat on numeroitu. Maalia pienet osat ennen kokoamista. Siirtokuvien kiinnittämisksi leikkaa ne arkista tarpeen mukaan. Kasta kuva lämpimään veteen muutama sekunnin ajaksi, anna takapuolen liukua kuvalle osoitettuun kohtaan. Käytetään yhdessä laatikon kuvituksen kanssa. EI sovittele alle kolmivuotiaille lapsille. Pajon irrotettavaa pikkusasia.

**DA** Studér tegningerne nøje og forsøg at sætte delene sammen, inden de klæbes sammen. Skrab forsigtigt malingen af de overflader, der skal klæbes sammen. Alle dele er nummererede. Små dele skal males, før de monteres. Overføringsbillederne påføres ved at klippe dem ud af arket, som påkrævet, dyppe dem i varmt vand i nogle få sekunder, hvorefter underlaget glides af i de viste positioner. Påføres ifølge illustrationerne på æsken. Ikke egnet til børn under 3 år på grund af tilstedeværelse af små aftagelige dele.

**ASSEMBLY ICON INSTRUCTIONS**

<p>Assembly phase Phase de montage Montagephase Fase di montaje Montieringfasen Fase di montaggio Montagephase Fase de montagem Montieringfase Kokoamisvaihe Faza składowania Φάση συναρμολόγησης</p>	<p>Cement Coller Kleben Pegar Limma Incollare Lijmen Colar Klæbes Limaa Kleić Κleić Συγκollήστε</p>	<p>Do not cement together No pas coller Nicht kleben No pegar Limma inte Non incollare Niet lijmen Não colar Skal ikke klæbes Alä limaa Nie kleić Μη συγκollήστε</p>	<p>Indicates final location Indique l'emplacement final Zeigt Endposition Indica la ubicación definitiva Anger slutmonteringsplats Sede di montaggio finale Geeft uiteindelijk locatie aan "Indica localizaçã final Viser endelig placering Osoittaa lopullisen sijainnin Oznacza miejsce docelowe Υποδεικνύει τελική τοποθεσία</p>	<p>Alternative part(s) provided Autre(s) pièce(s) fournie(s) Ersatzteil(e) mitgeliefert Se incluye(n) pieza(s) alternativa(s) Alternativ(a) del(ar) ingår Uno o più componenti alternativi forniti Alternatieve onderdelen meegeleverd Peça(s) alternativa(s) fornecida(s) Alternativ(e) del(e) medfølger Vaihtoehtoiset osat pakkaussessa Dost epne z eści zamienne Παρέχονται εναλλακτικά κομμάτια</p>	<p>Repeat this operation Répéter l'opération Vorgang wiederholen Repètir la operación Upprepa åtgärden Ripetere l'operazione De verrichting herhalen Repètir a operação Manöver gentages Toista toimenpite Powtórzyć c operację Επαναλάβετε τη διαδικασία</p>	
<p>Decals Dcalcomanias Abziehbild Calcomanias Dekaler Decalcomanie Stickers Decalcomania Billedoverføring Siirtokuvat Kalkomanie Χαρκομανίες</p>	<p>Crystal part Pièce cristal Kristallteil Piazza de cristal Kristalldel Pezzo cristallo Kristallen onderdeel Peça de cristal Kryсталтыккe Kristallosa Część kryształowa Κομμάτι κρυστάλλου</p>	<p>Weight Lester Beschweren Lastrar Belasta Applicare un peso Verzwaren Lastrar Påfor vægt Aseta vastapaino Obciążać balastem Επιβάρεστε βάρος</p>	<p>Remove by filing Enlever avec une lime Abfeilen Eliminar con lima Ta bort genom att fila Rimovare con la lima Verwijderen door afvijlen Remova liando Fijem ved at file væk Poista villaamalla Usunąć przy użyciu pilnika Αφαιρέστε λιμάροντας με λίμα</p>	<p>Drill or pierce Percer Durchbohren Perforar Borra Trapanare o forare Boren of doorboren Furar Gennembor Poraa tai puhkaise Wywierćić lub przedziurawić Τρυπήστε</p>	<p>Cut Découper Schneiden Cortar Skär Tagliare Snijden Cortar Skær Leikkaa Przećić Κόψτε</p>	<p>Humbrol paint number No peinture Humbrol Humbrol-Farbummer No de pintura Humbrol Humbrol färg nummer No vemice Humbrol Humbrol-verfnummer No de pintura Humbrol Humbrol maalingsnummer Humbrol-maalin numero Nr farby Humbrol Νόμepο χρώματος Humbrol</p>

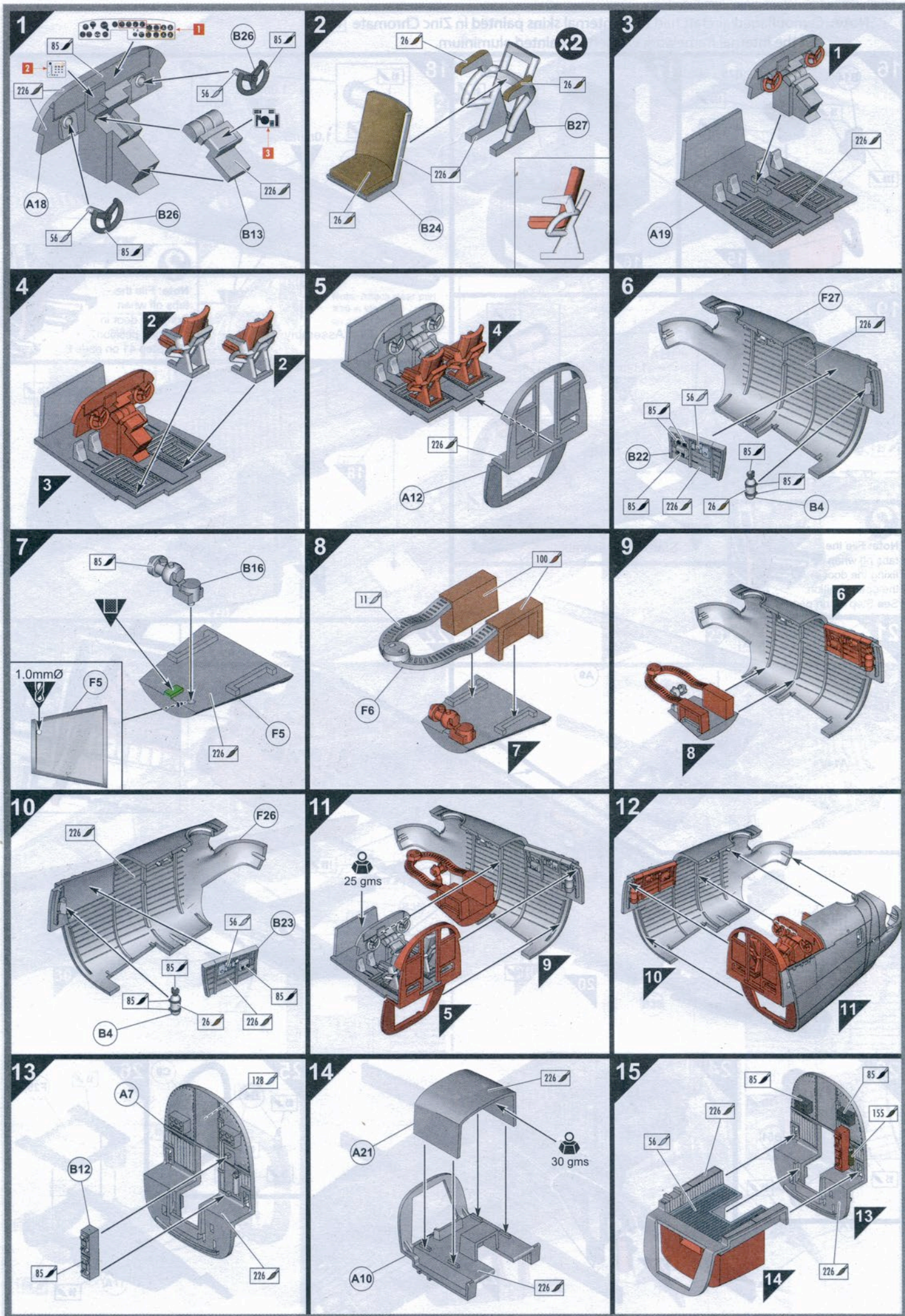

**Note:** Camouflaged aircraft had their internal skins painted in Zinc Chromate  but the internal framework was left unpainted aluminium.

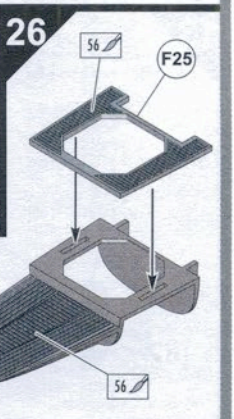
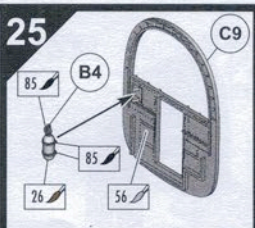
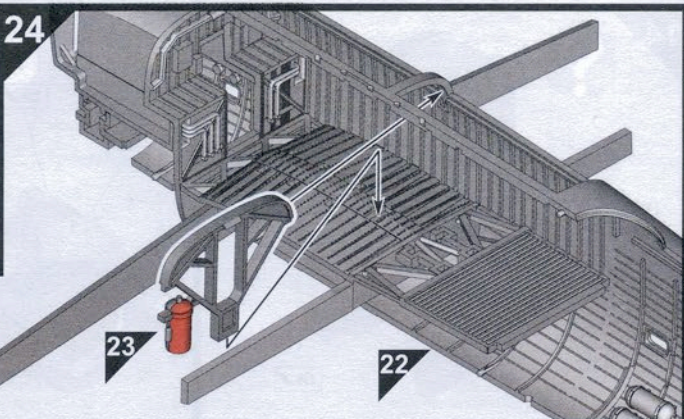
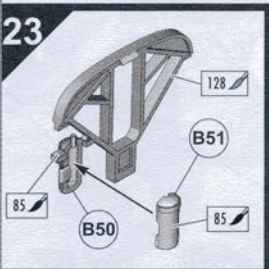
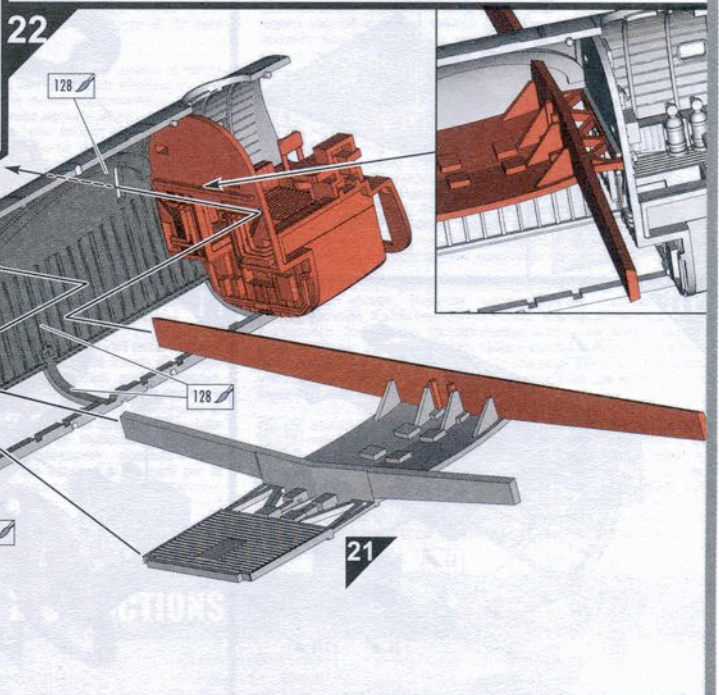
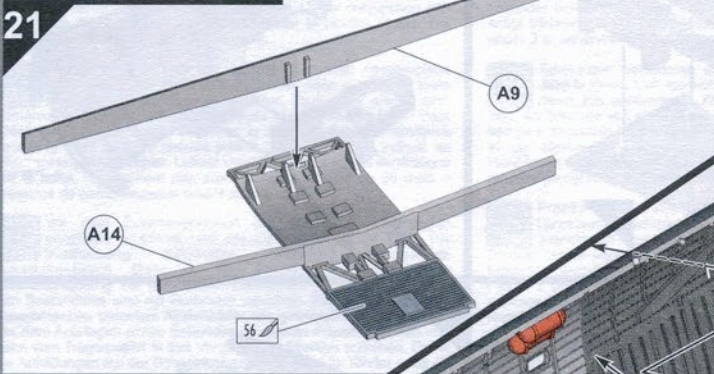
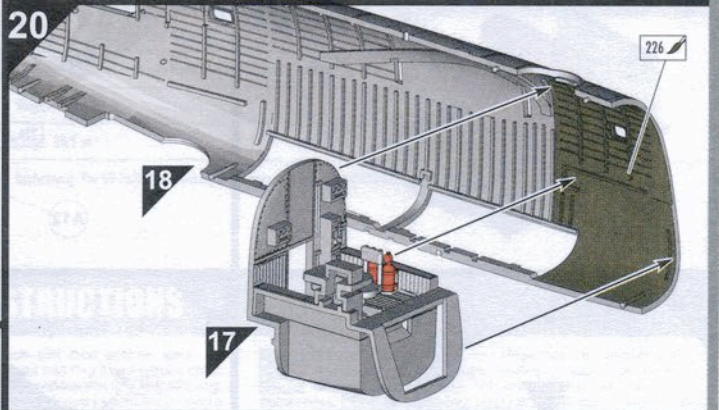
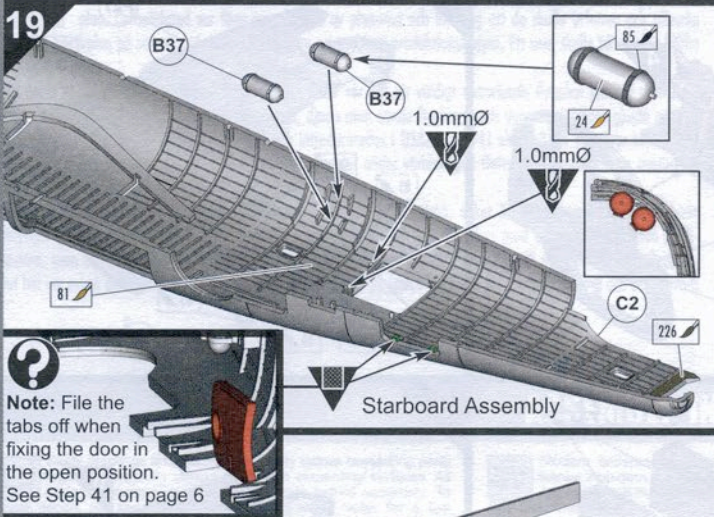
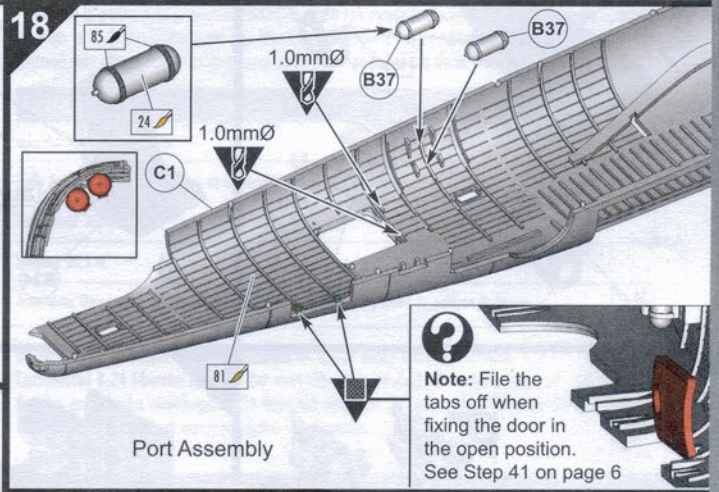
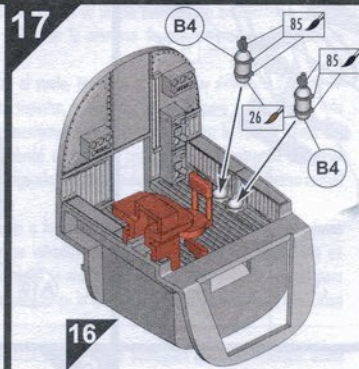
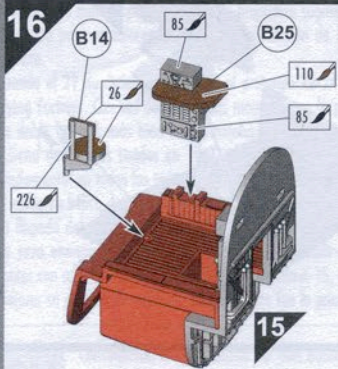

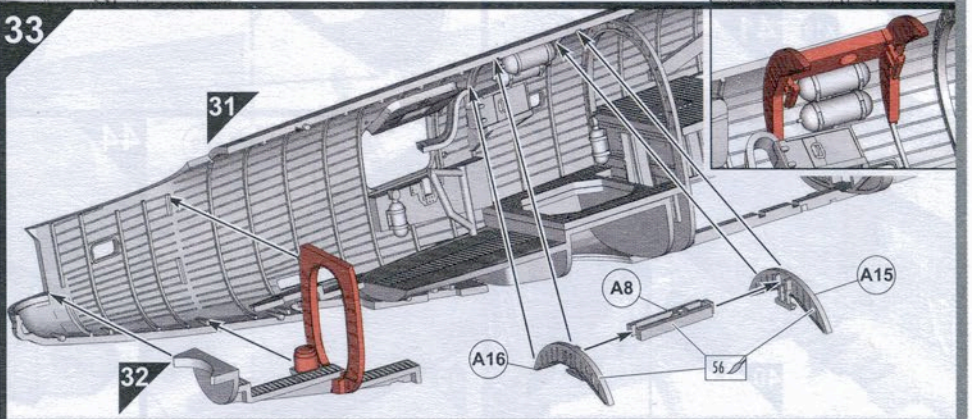
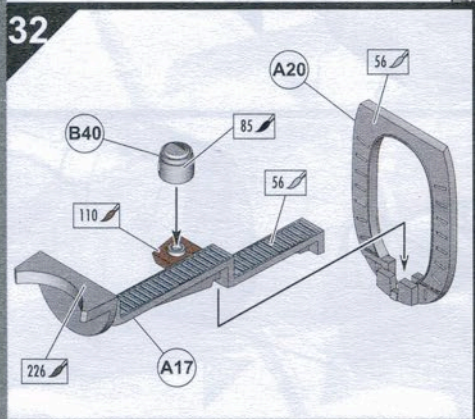
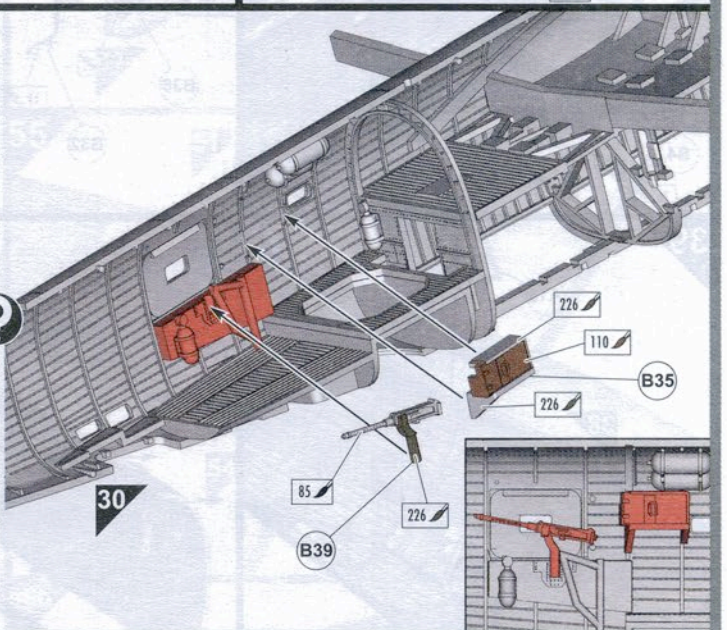
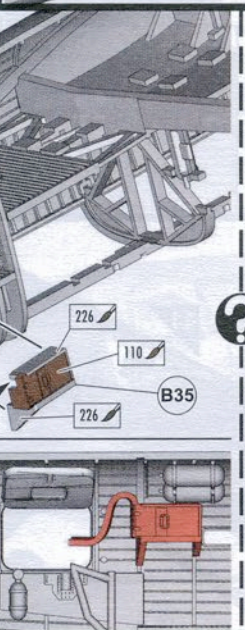
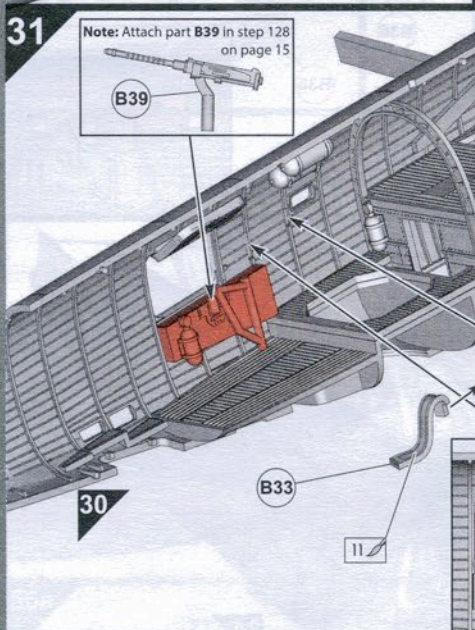
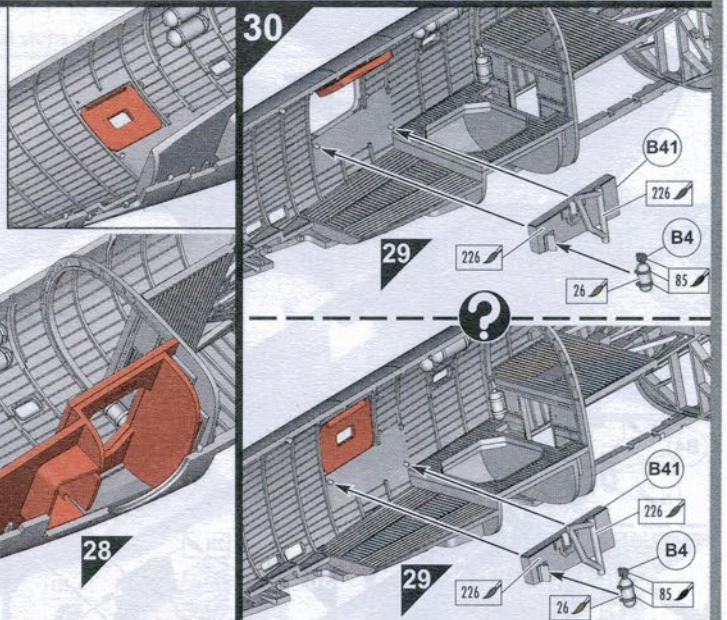
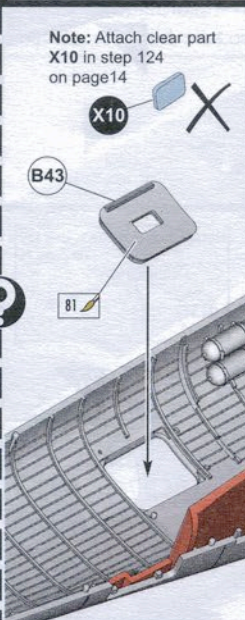
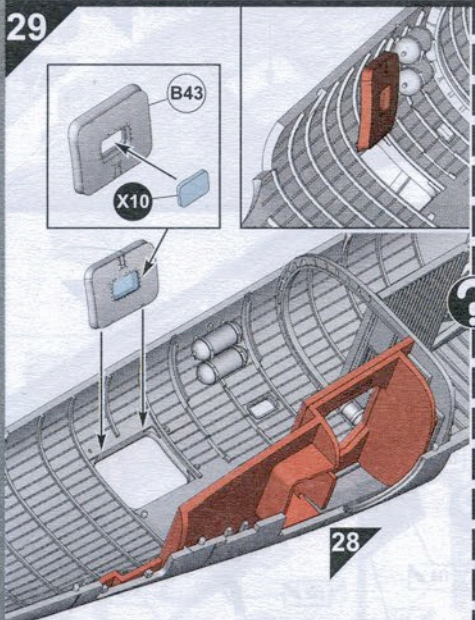
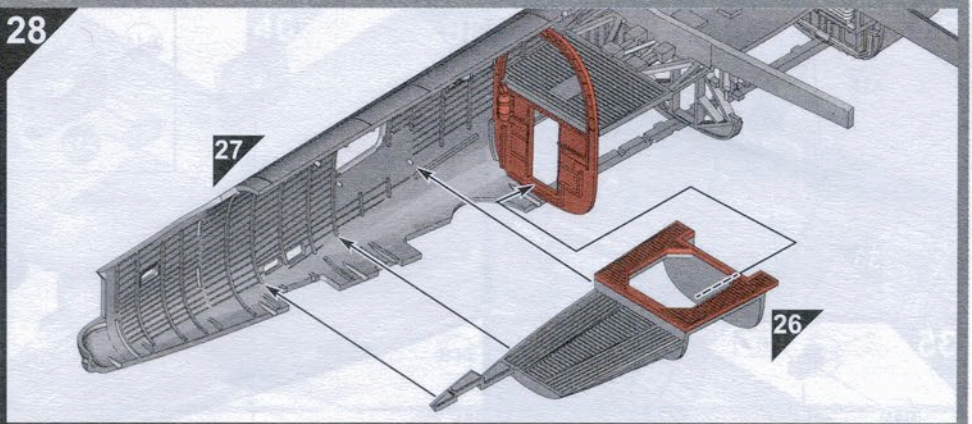
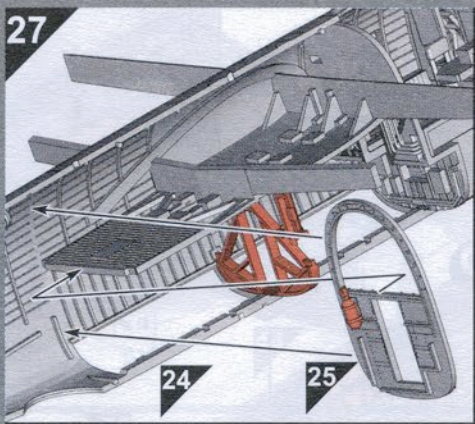

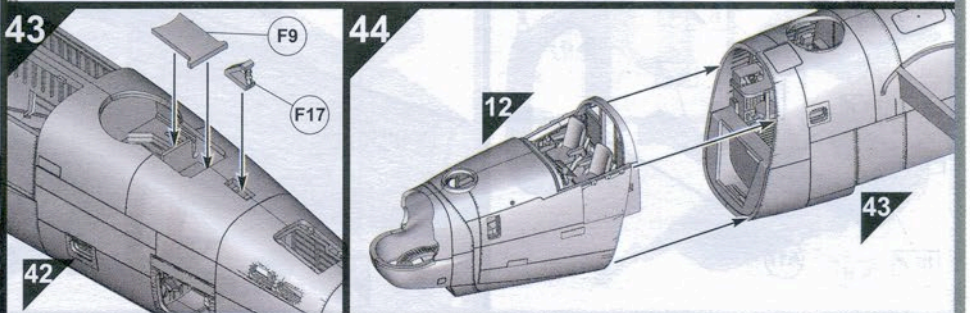
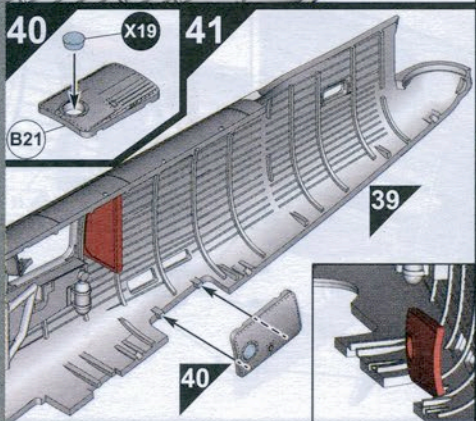
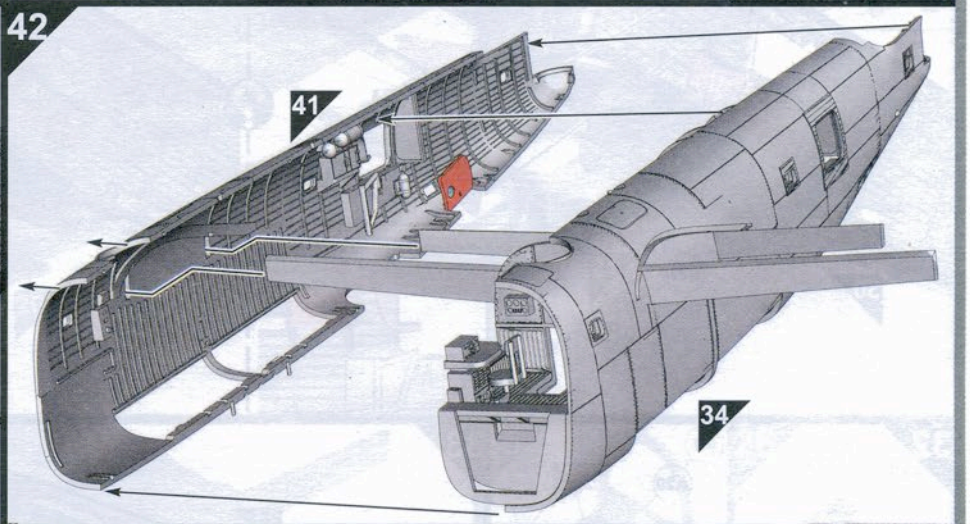
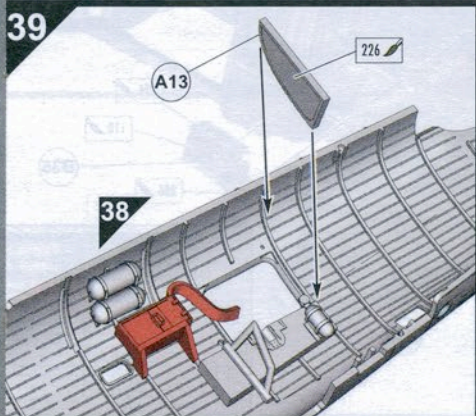
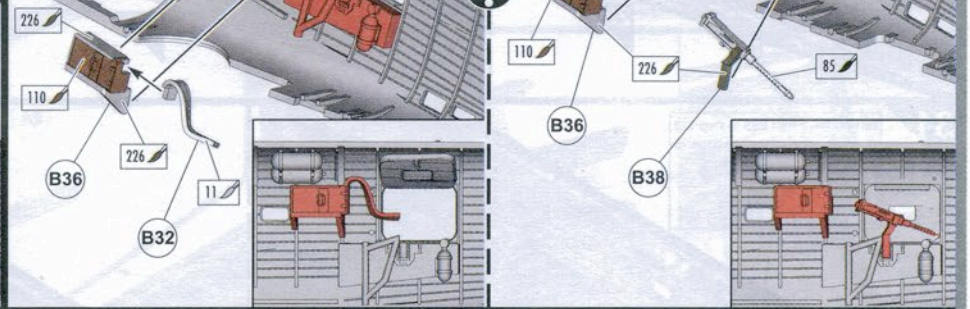
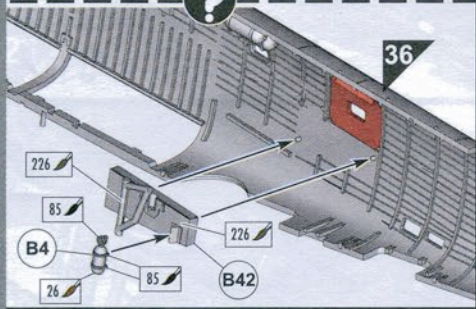
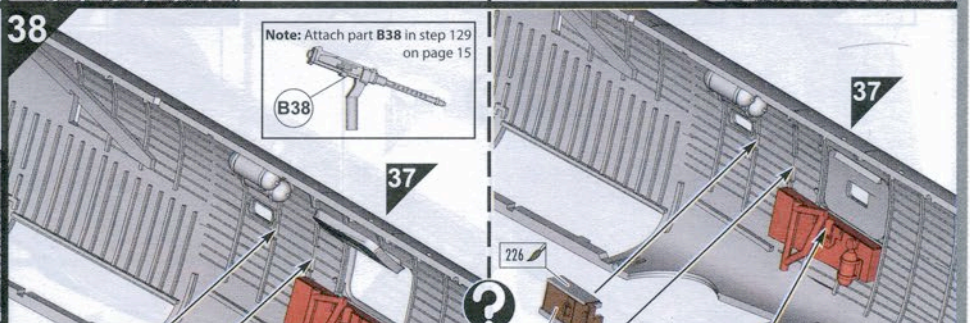
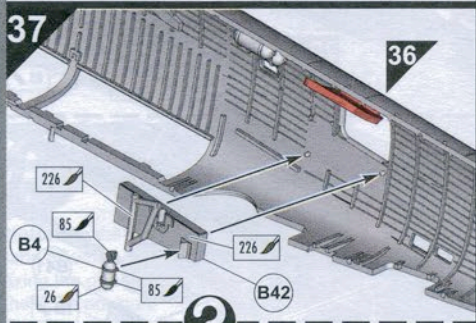
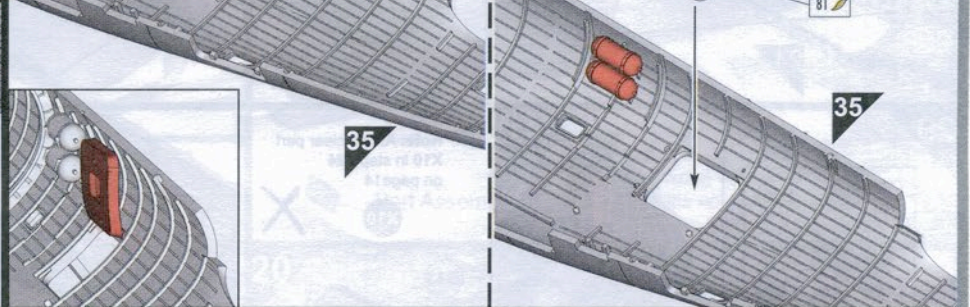
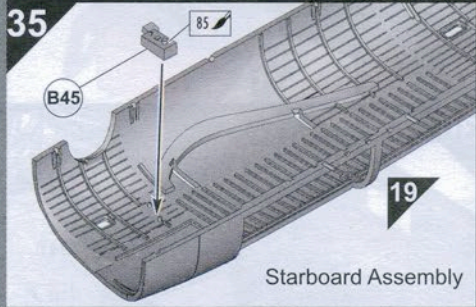
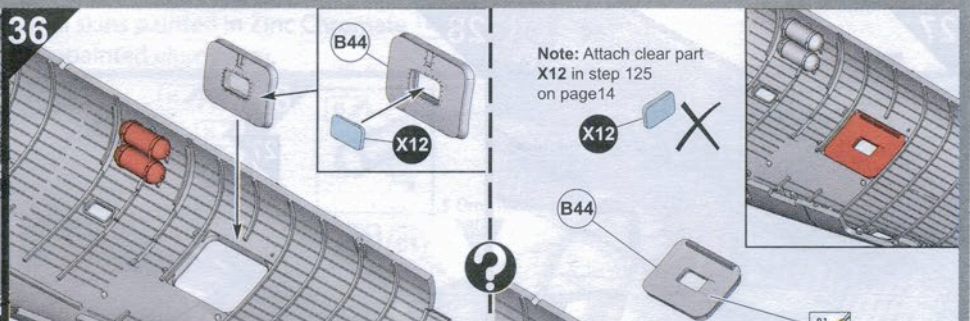
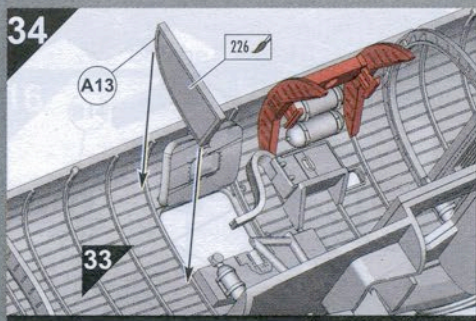

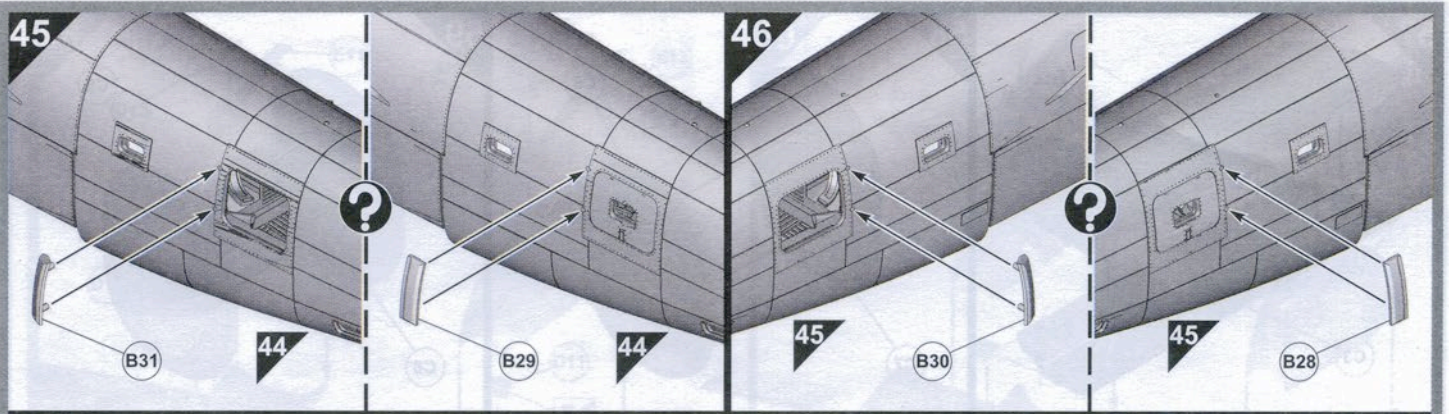

**?** Note: When building this model with Bomb bay doors open, follow steps 47 to 56a.  
When building this model with Bomb bay doors closed, miss out steps 47 to 56a and carry on from Step 56b.

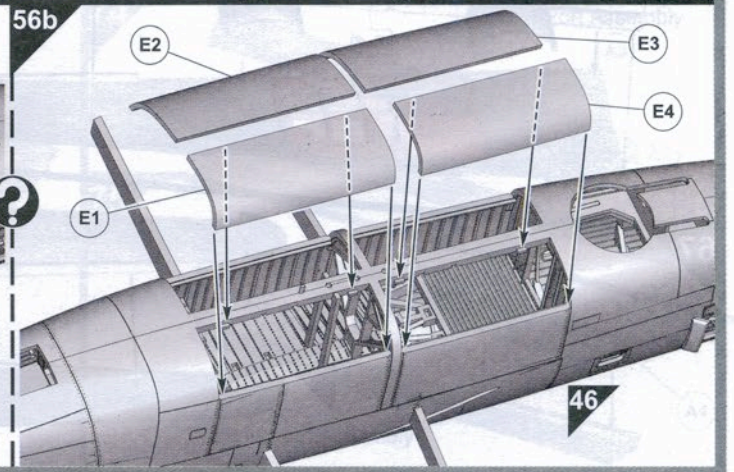
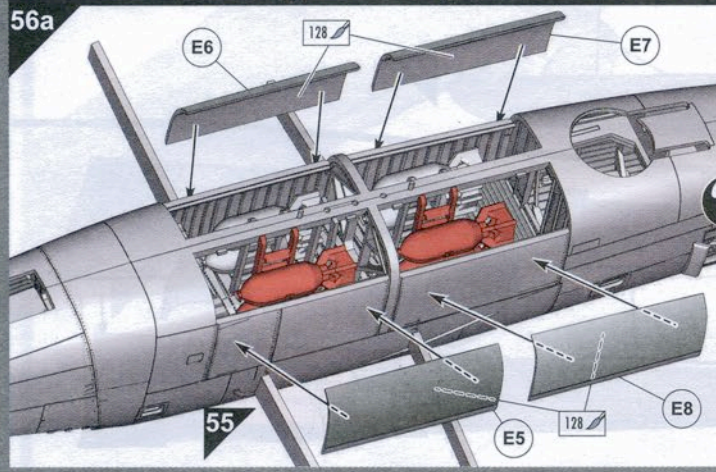
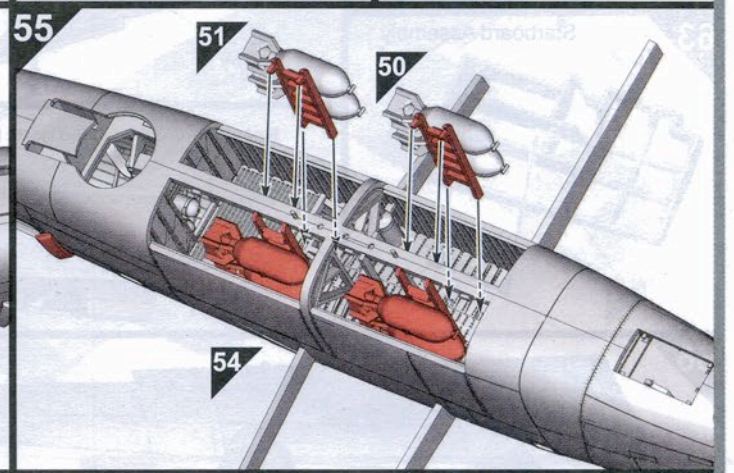
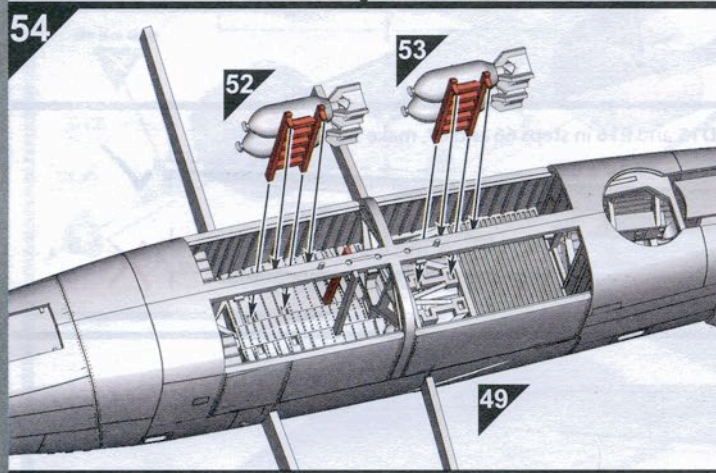
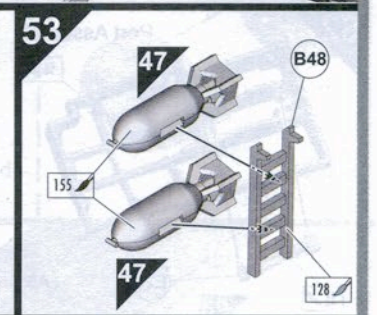
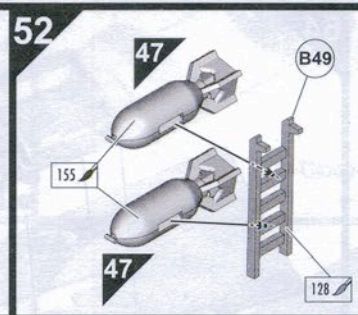
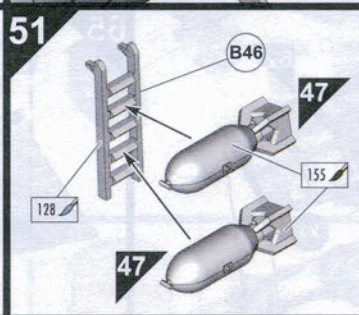
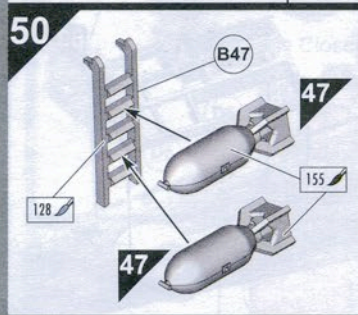
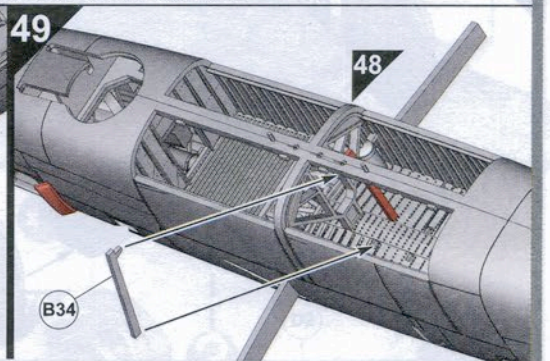
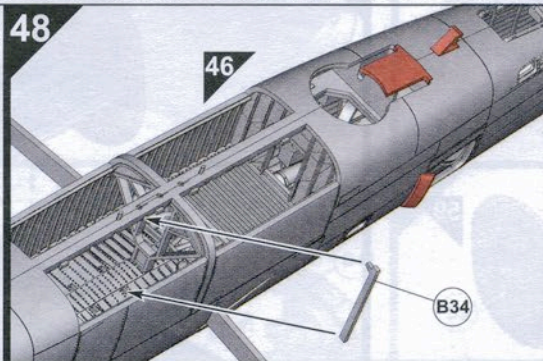
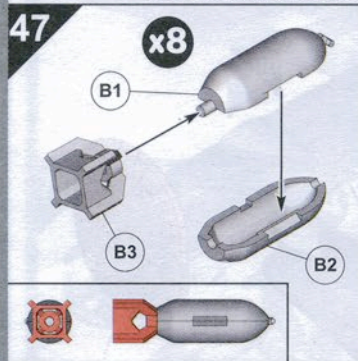

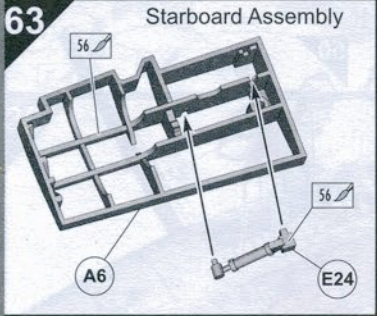
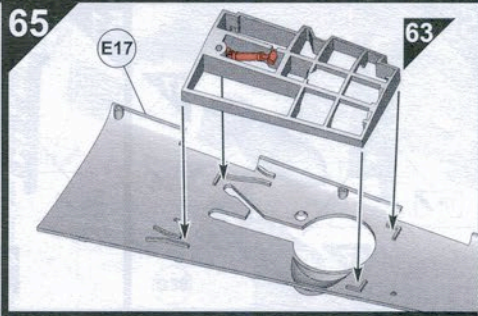
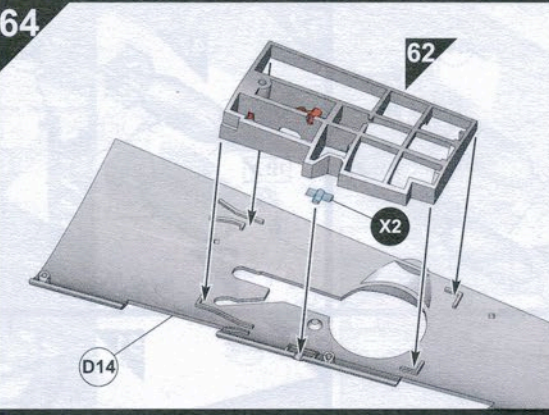
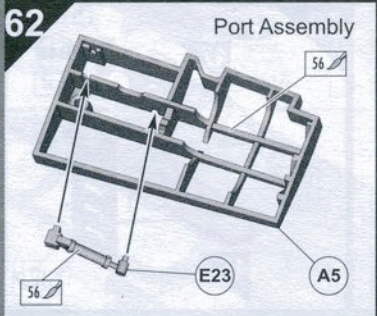
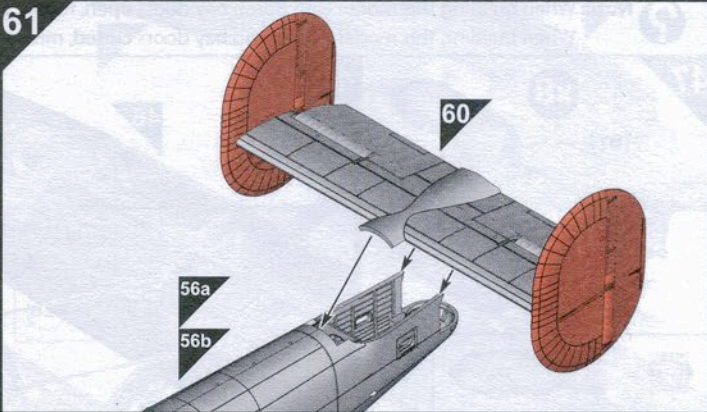
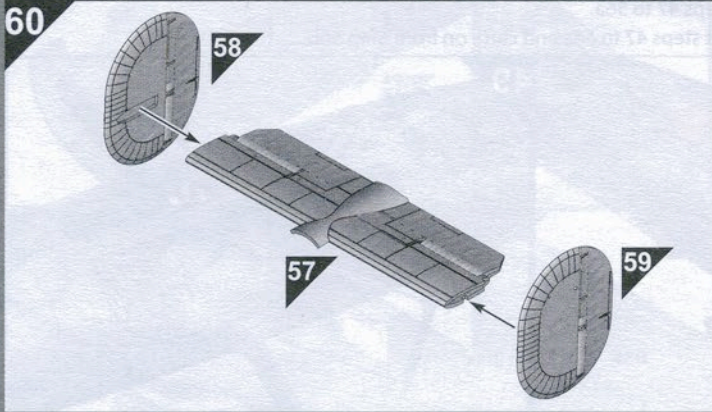
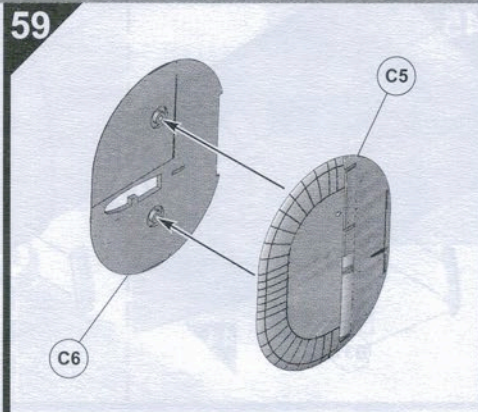
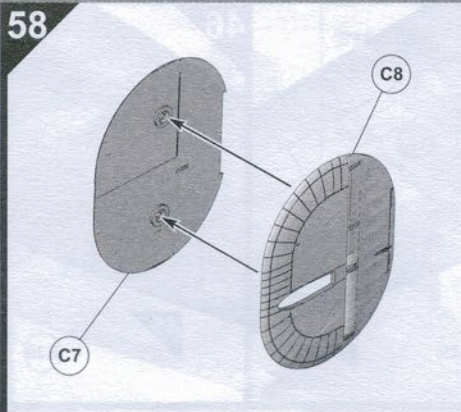
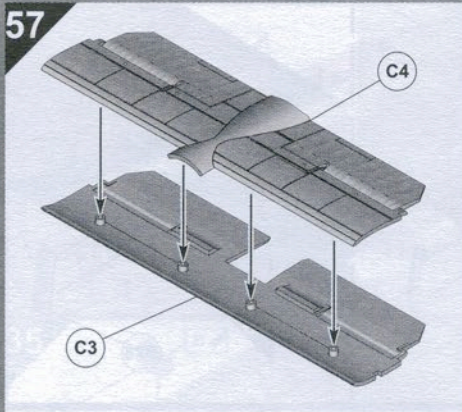

**Note:** When assembling parts **D15** and **E16** in steps 66 and 67, make sure ?

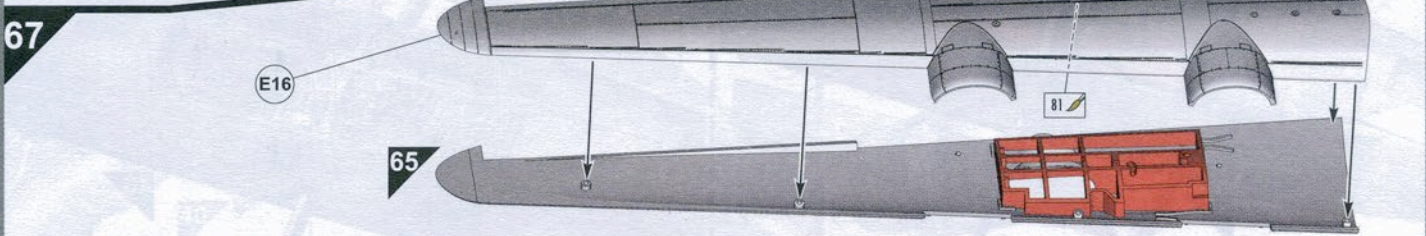
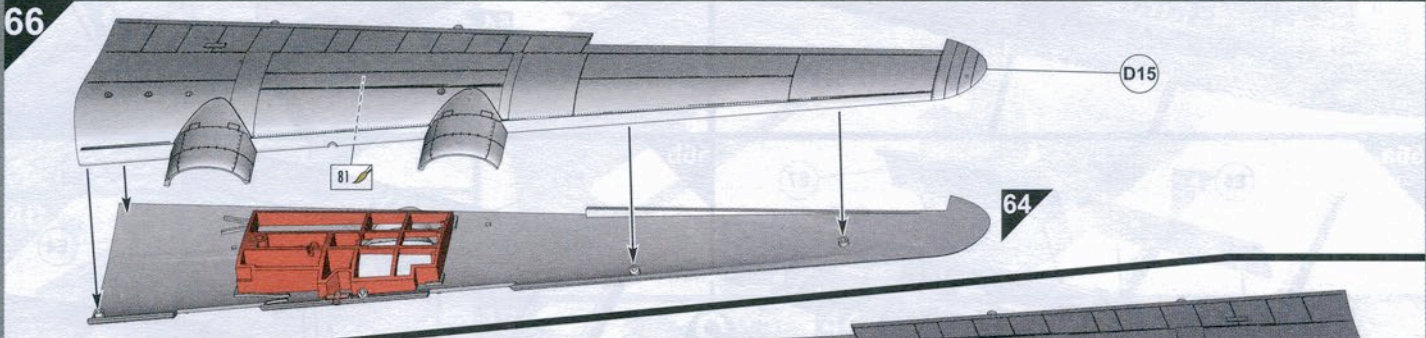
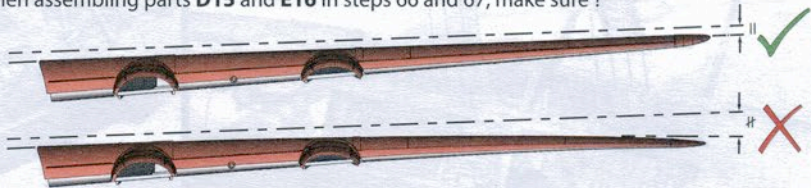

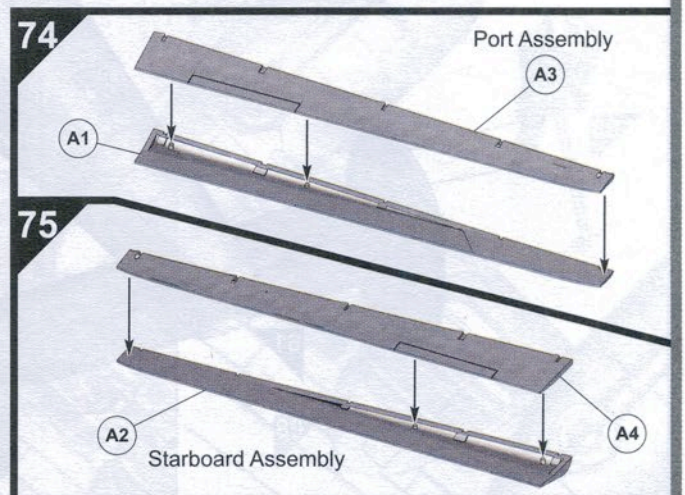
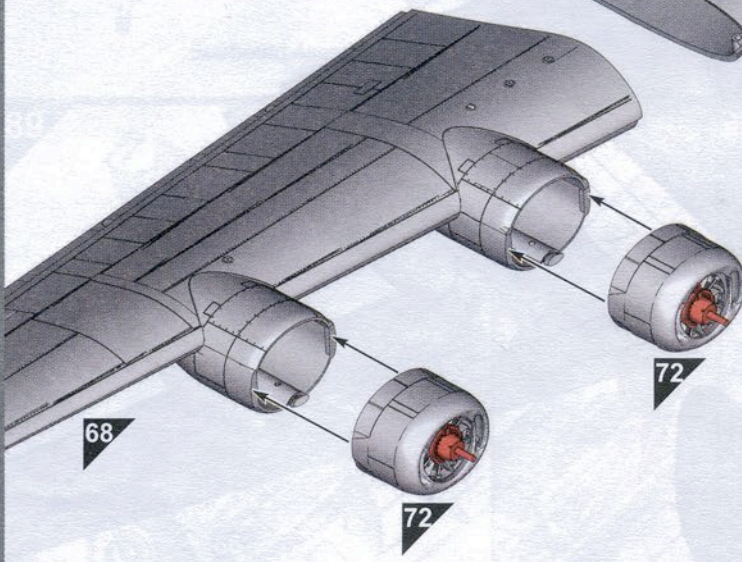
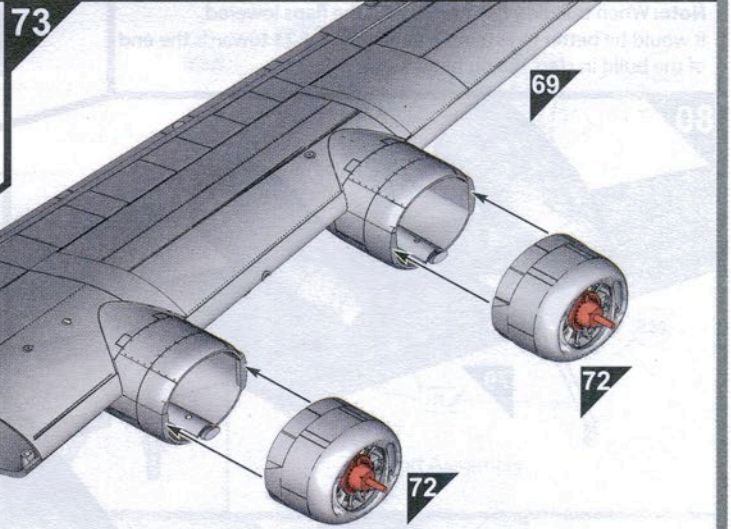
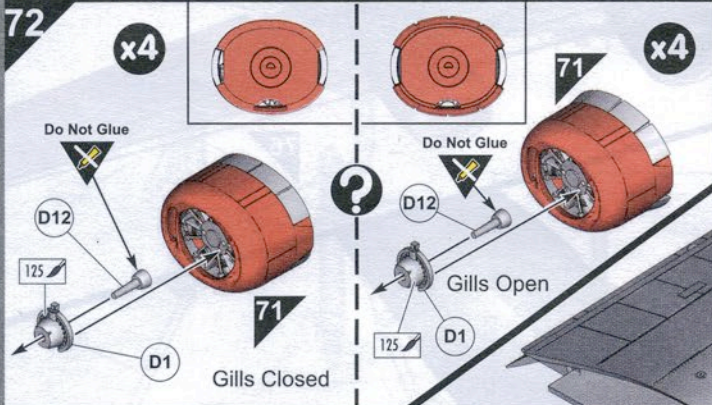
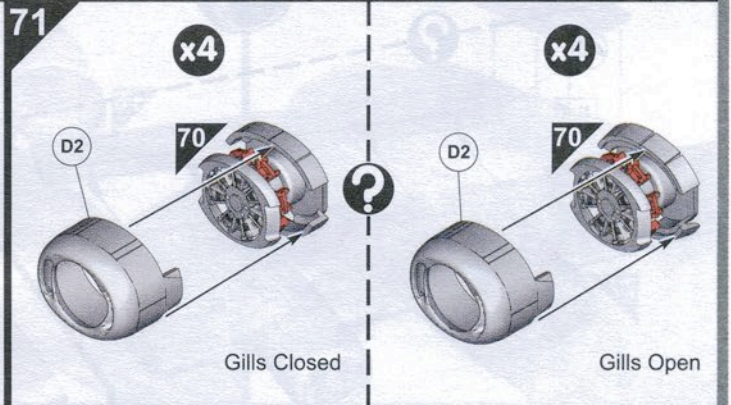
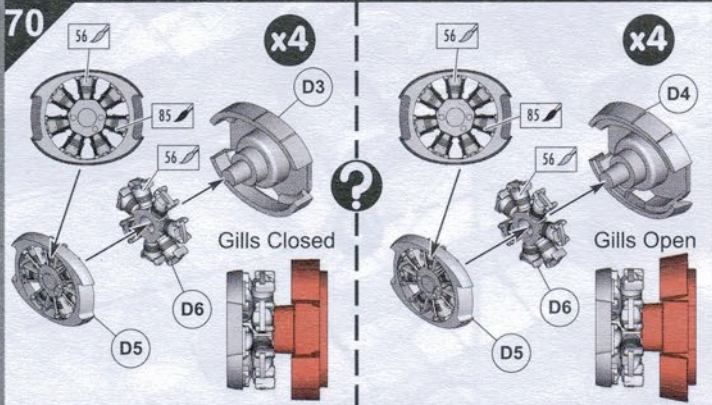
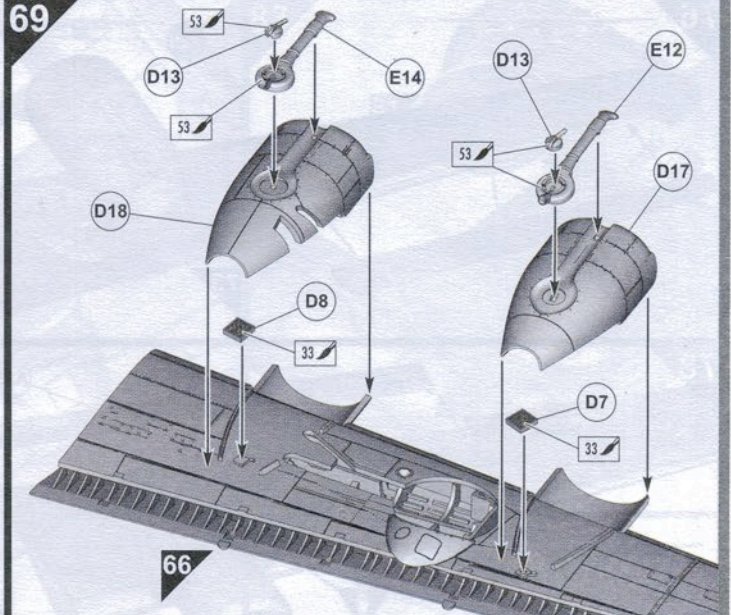
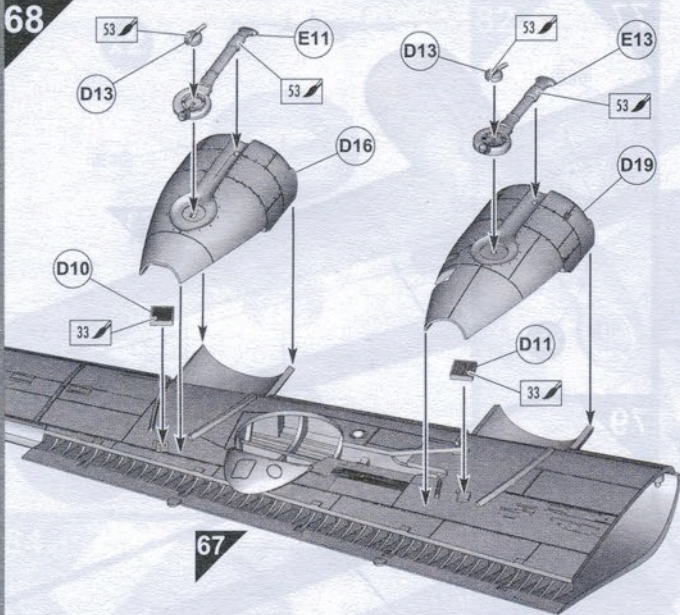

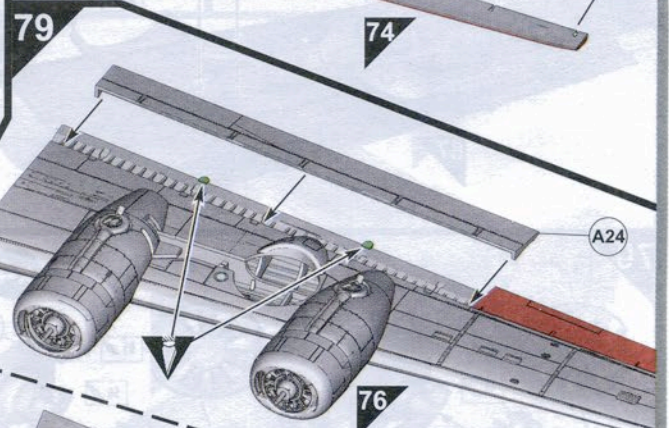
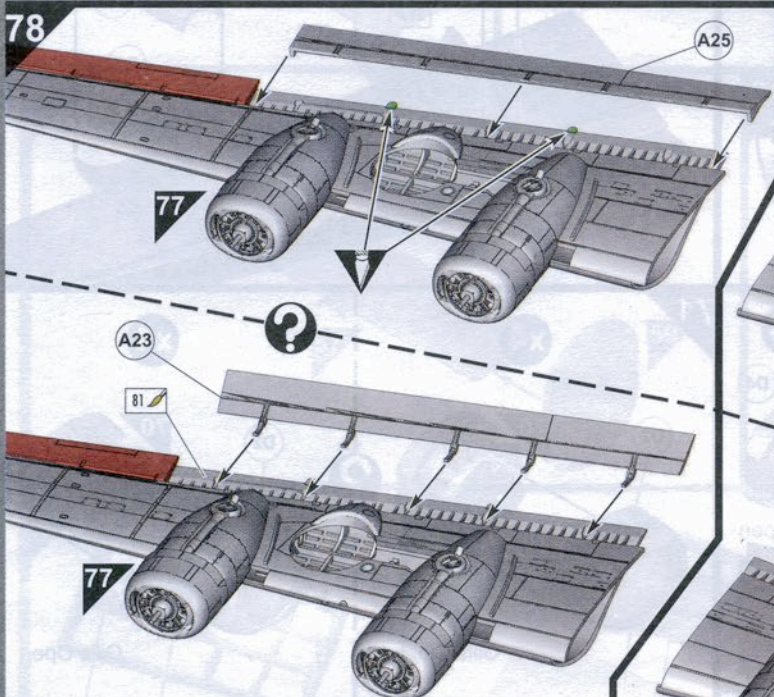
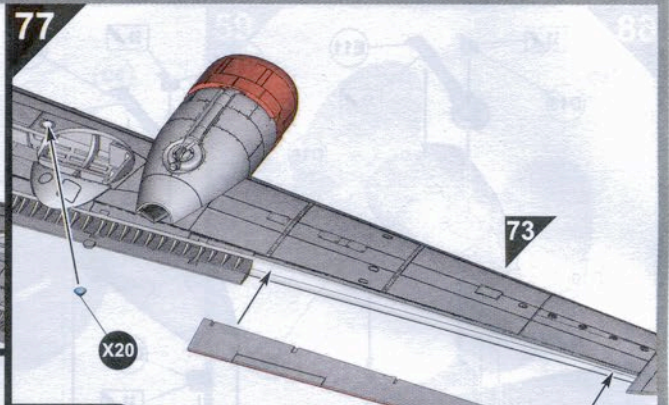
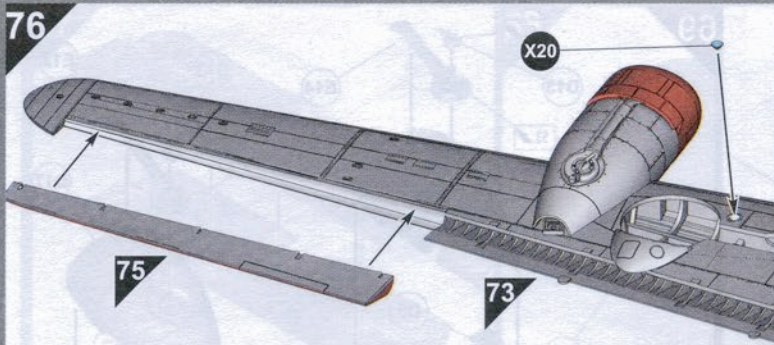

**Note:** When building this model with the flaps lowered, it would be better to assemble parts A22 & A23 towards the end of the build in step 126 on page 15.

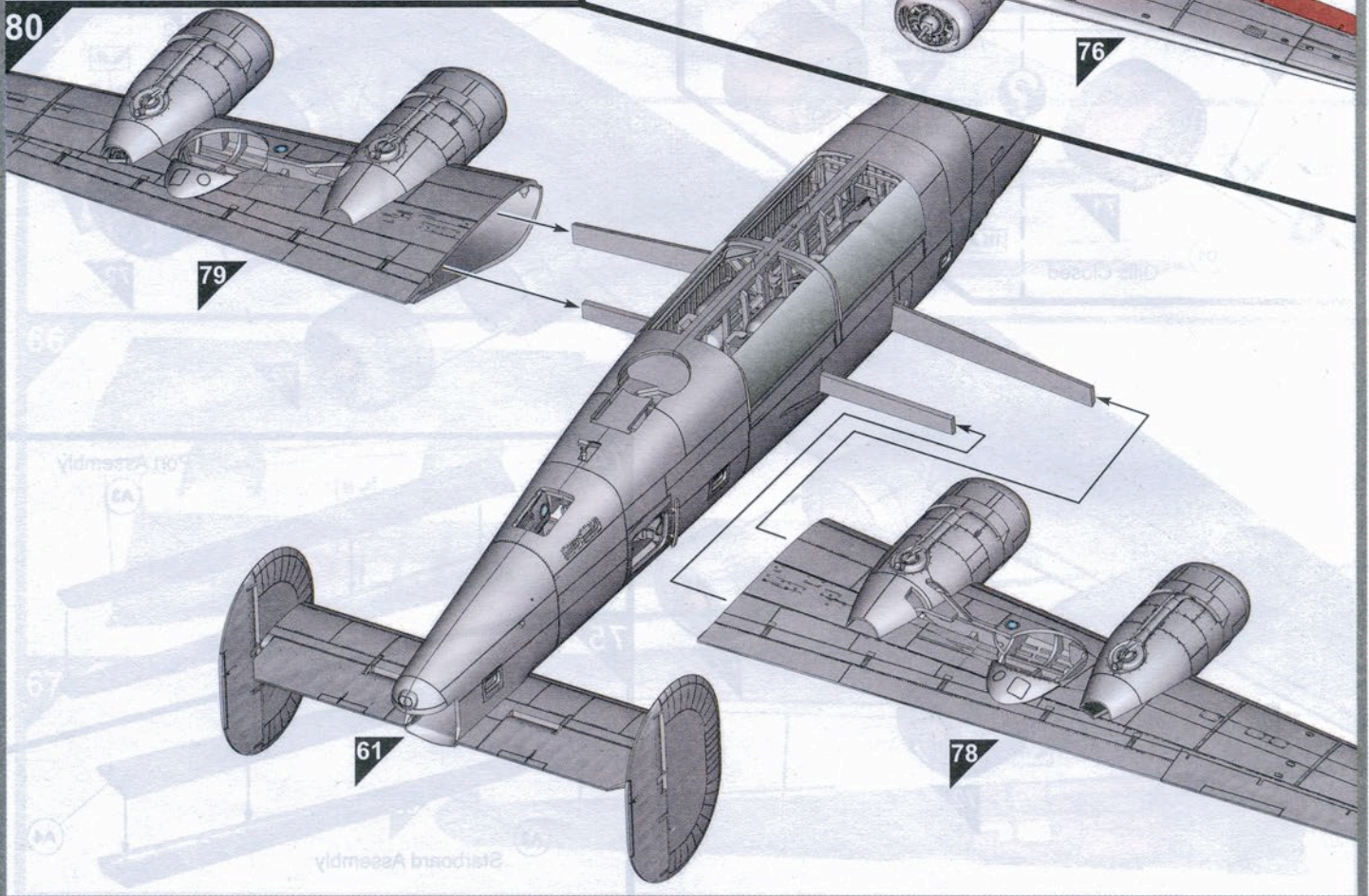

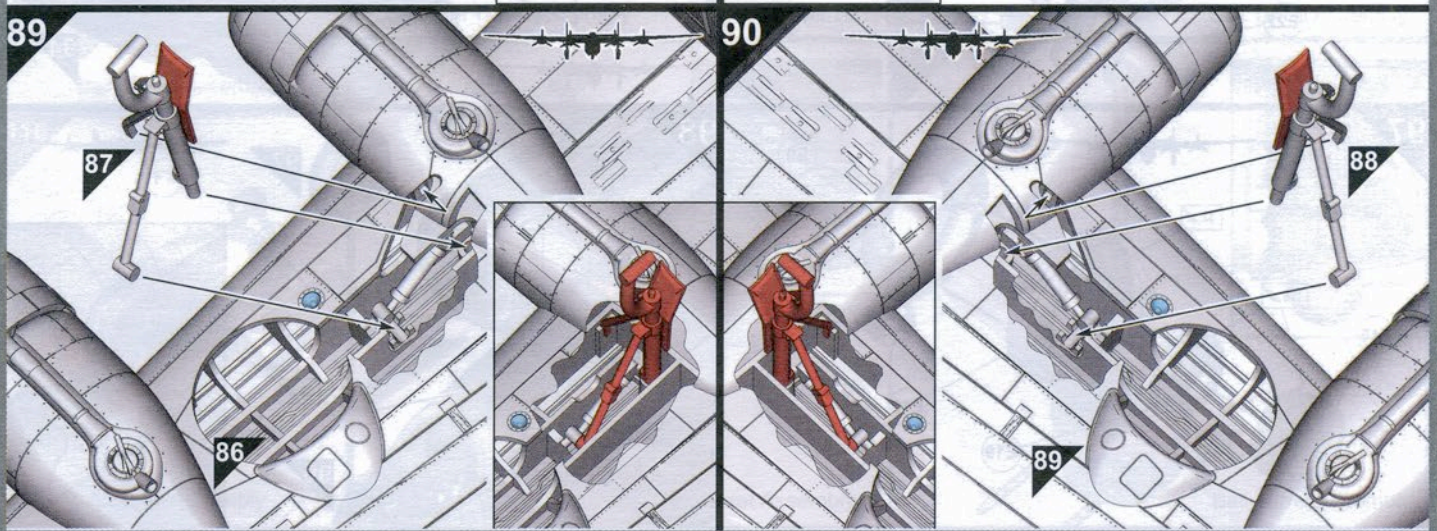
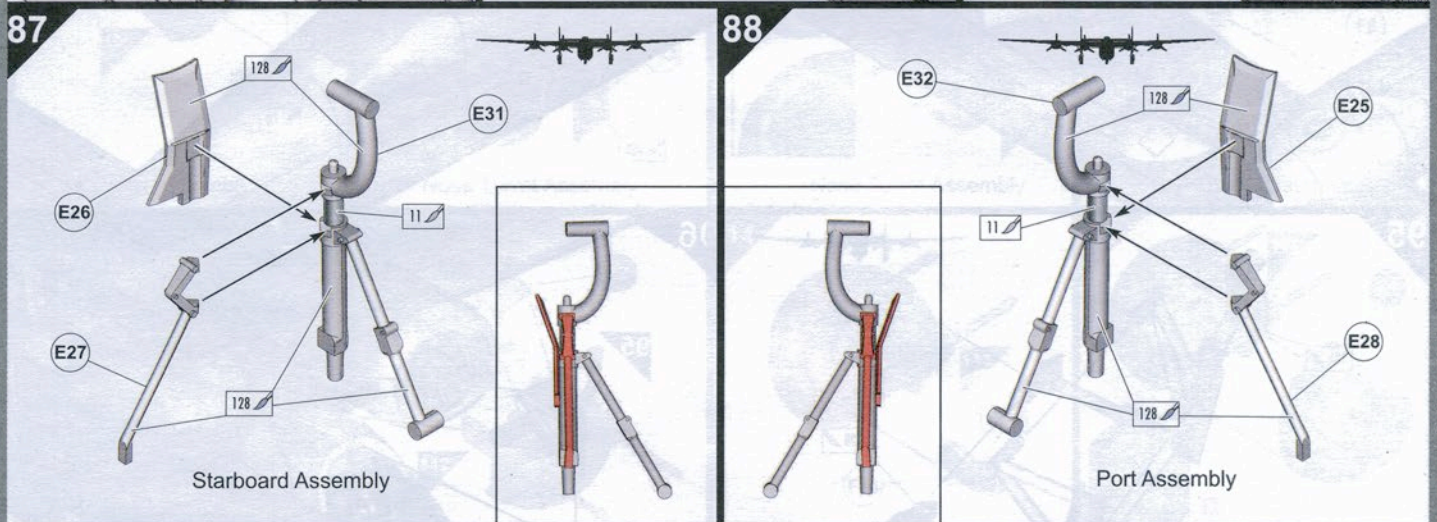
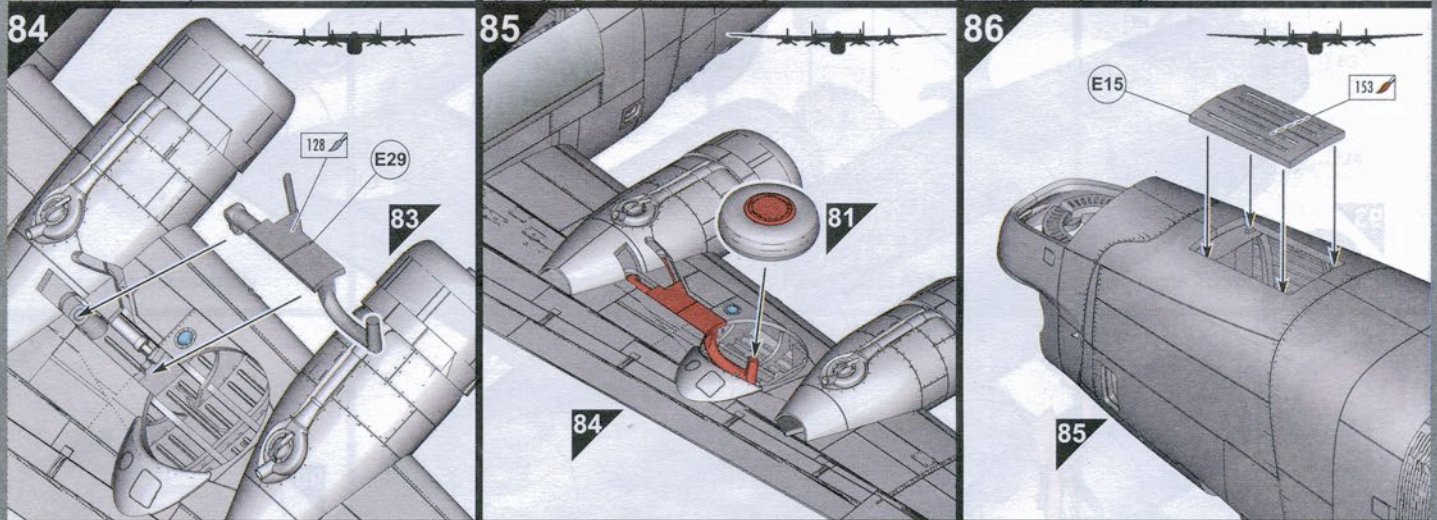
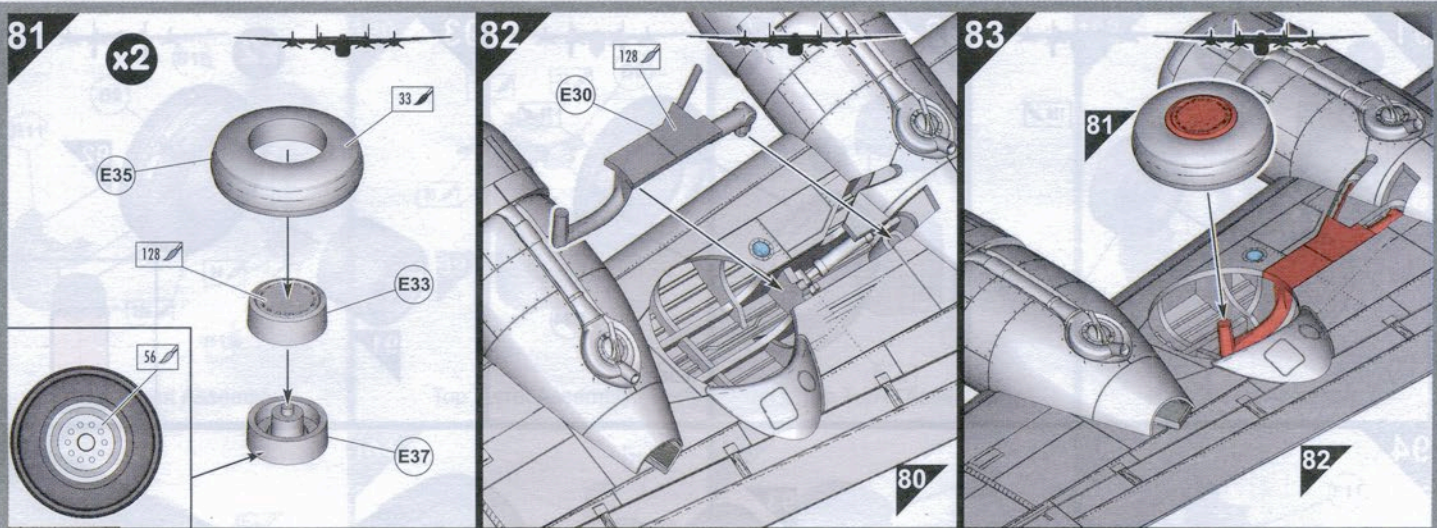

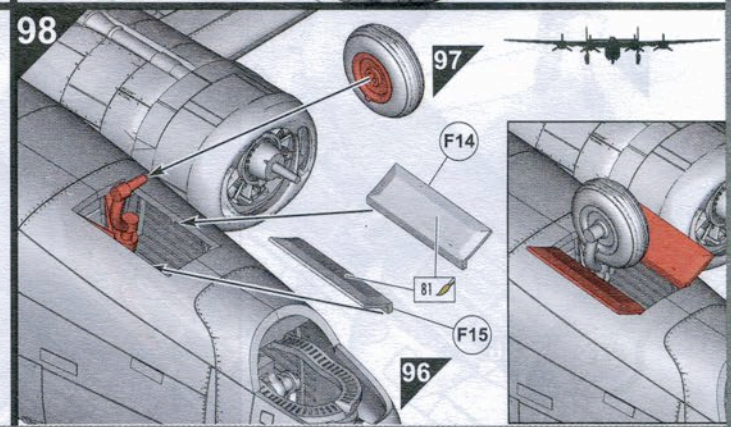
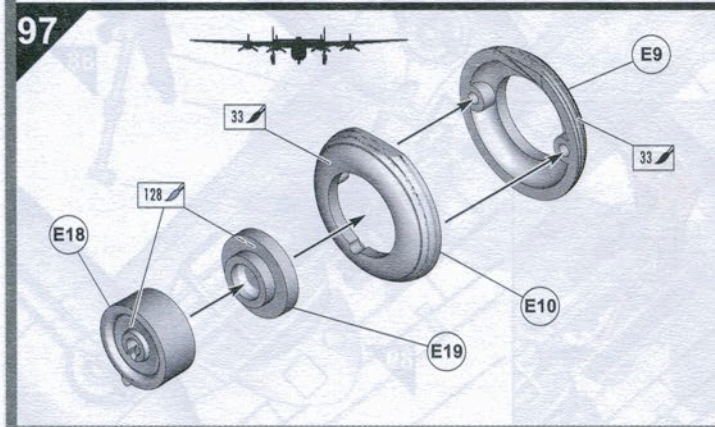
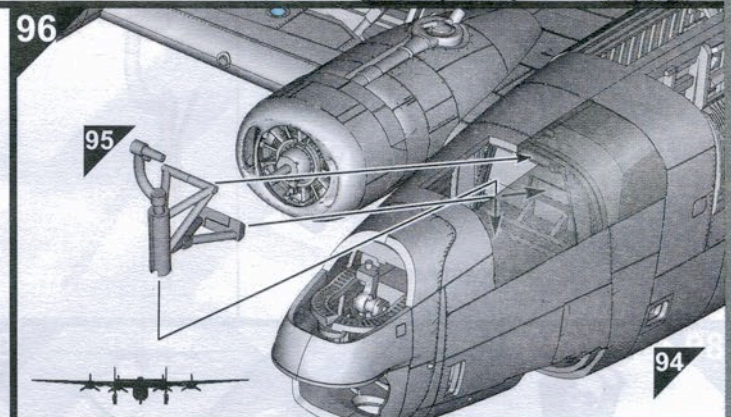
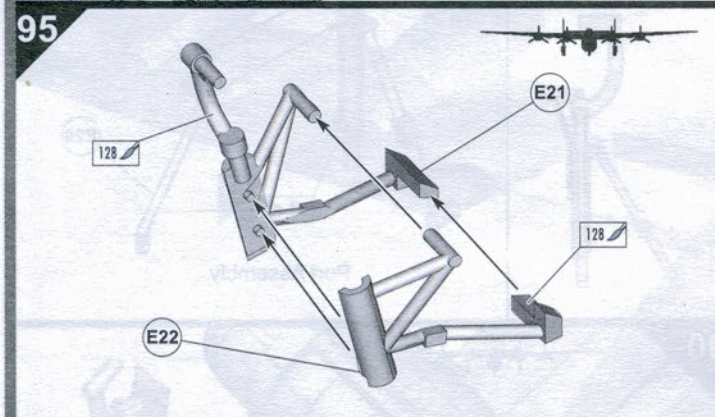
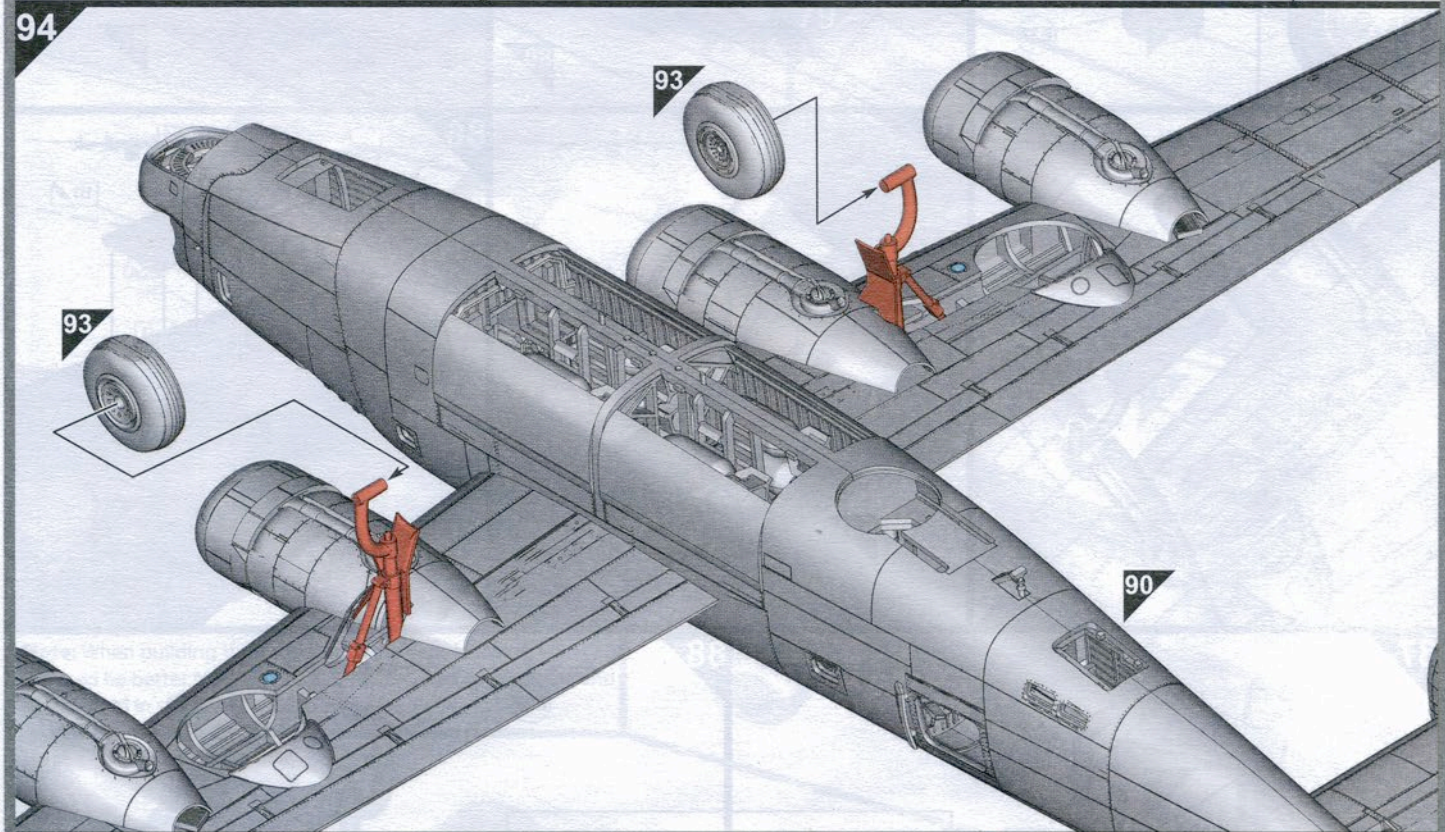
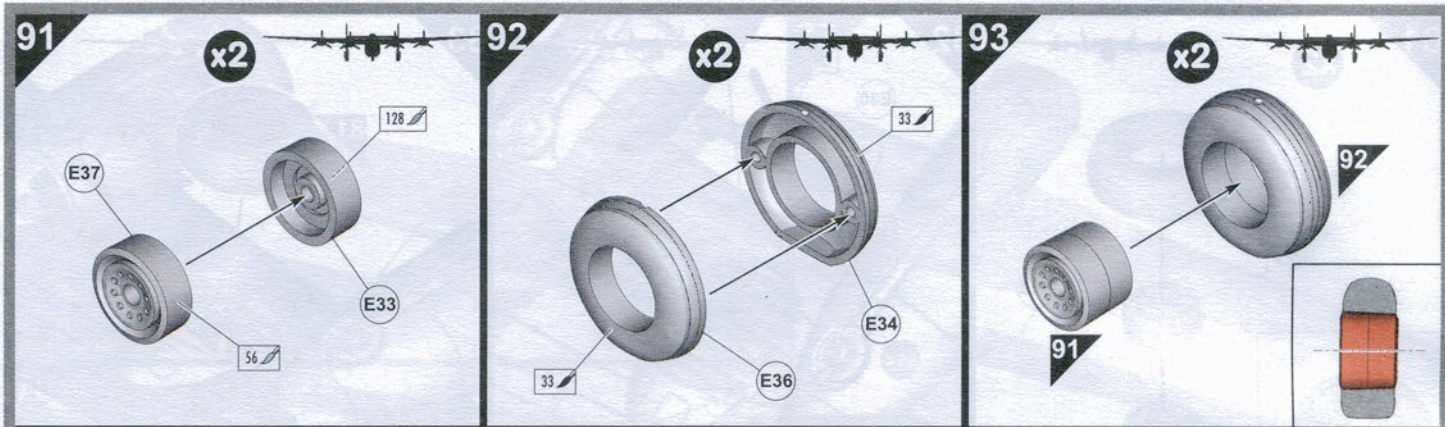

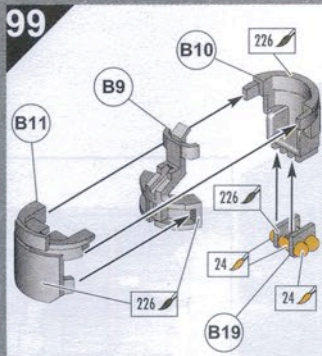

Top Turret Assembly

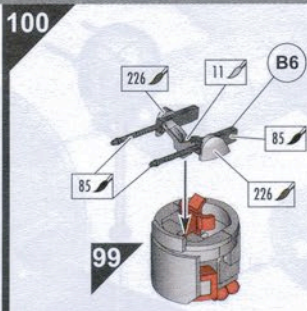

Top Turret Assembly

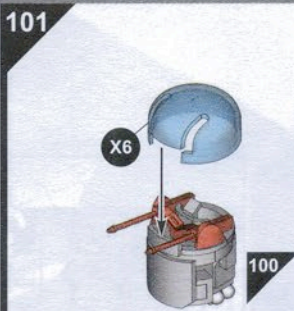

Top Turret Assembly

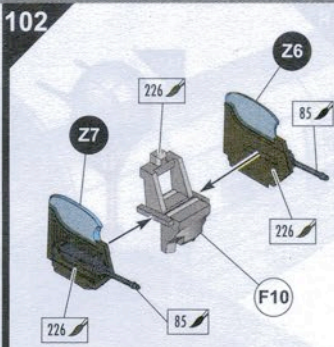

Rear Turret Assembly

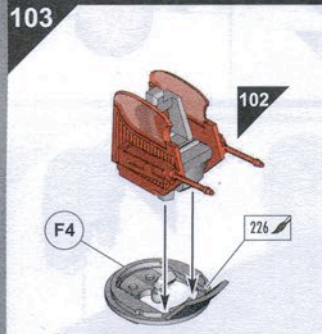

Rear Turret Assembly

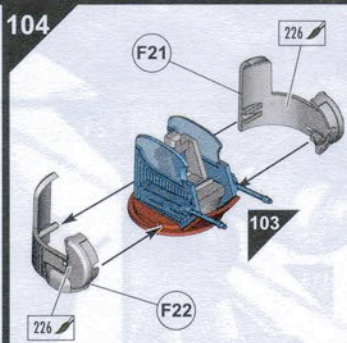

Rear Turret Assembly

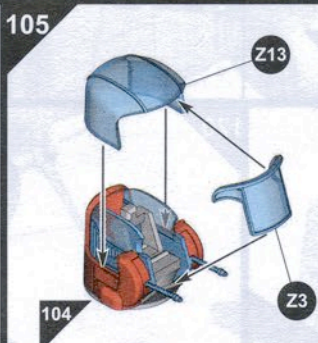

Rear Turret Assembly

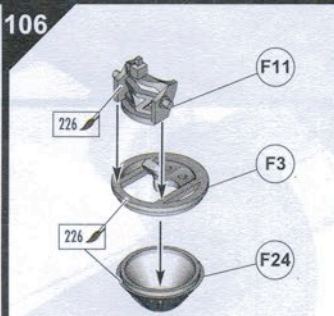

Nose Turret Assembly

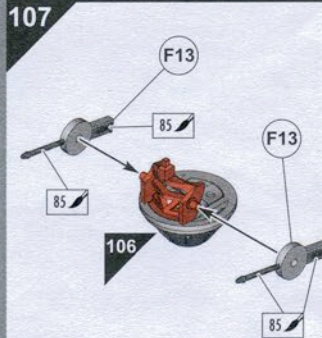

Nose Turret Assembly

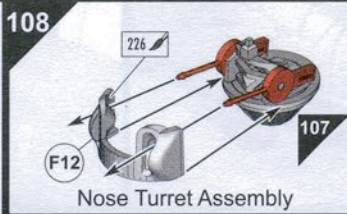

Nose Turret Assembly

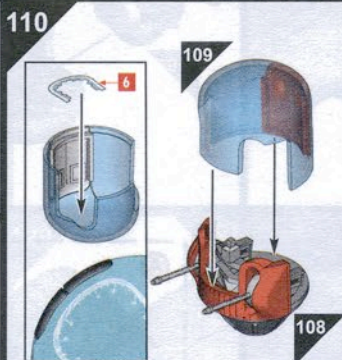

Nose Turret Assembly

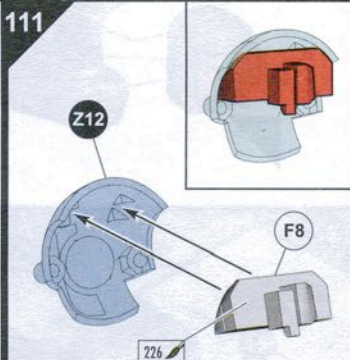

Ball Turret Assembly

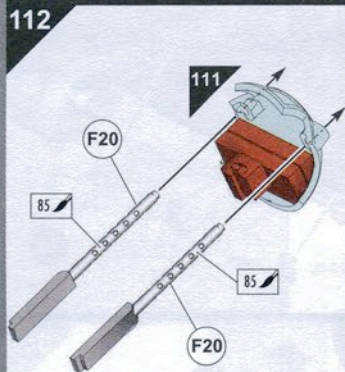

Ball Turret Assembly

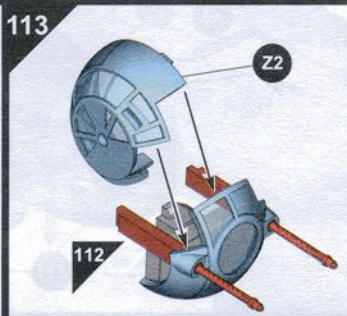

Ball Turret Assembly

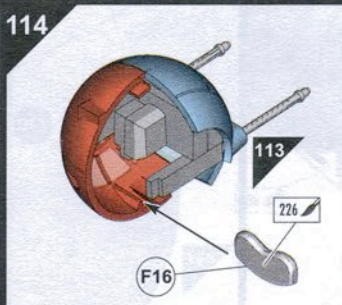

Ball Turret Assembly

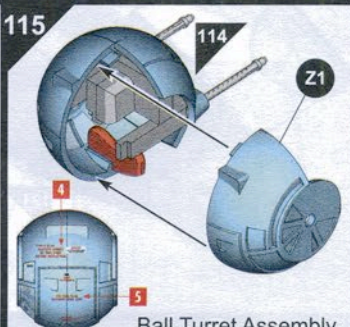

Ball Turret Assembly

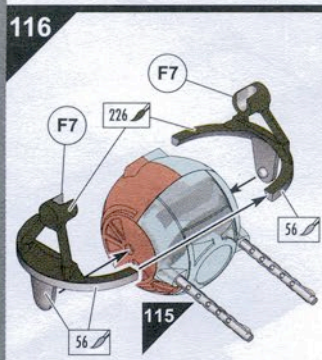

Ball Turret Assembly

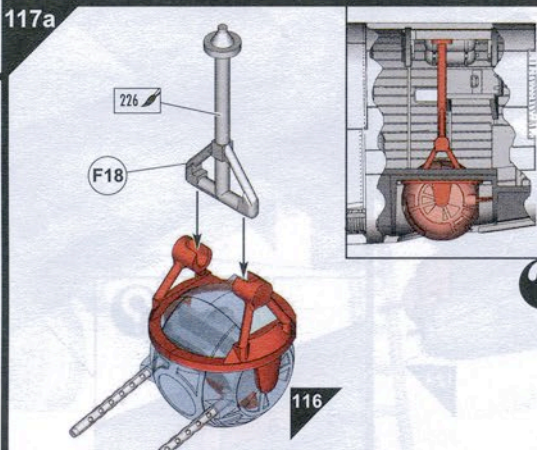

Ball Turret Assembly

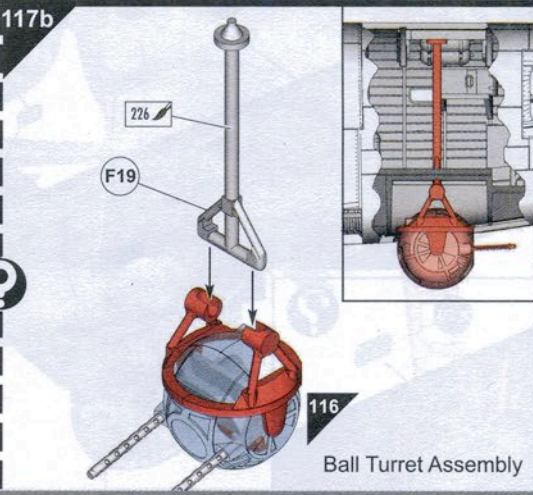

Ball Turret Assembly

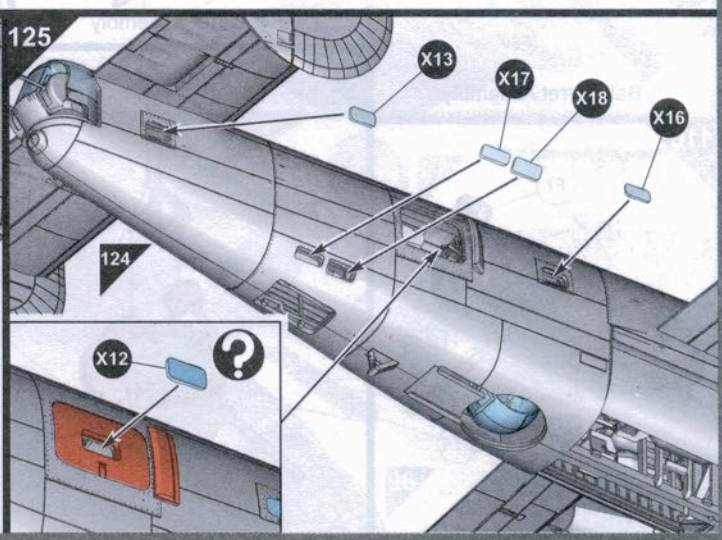
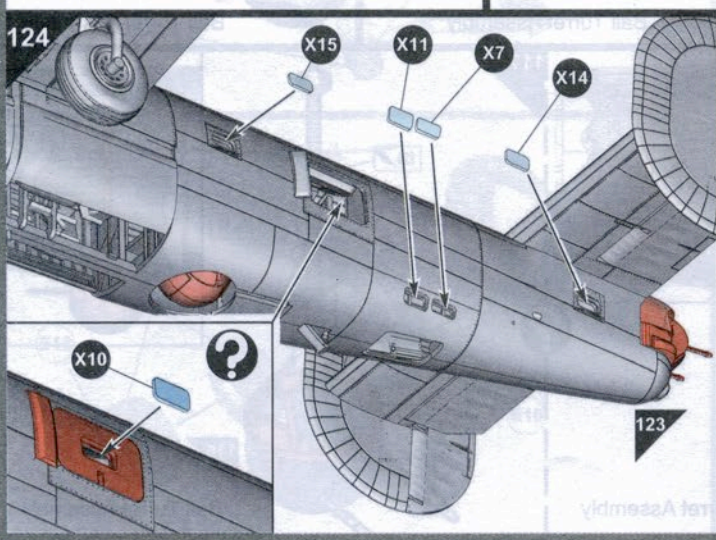
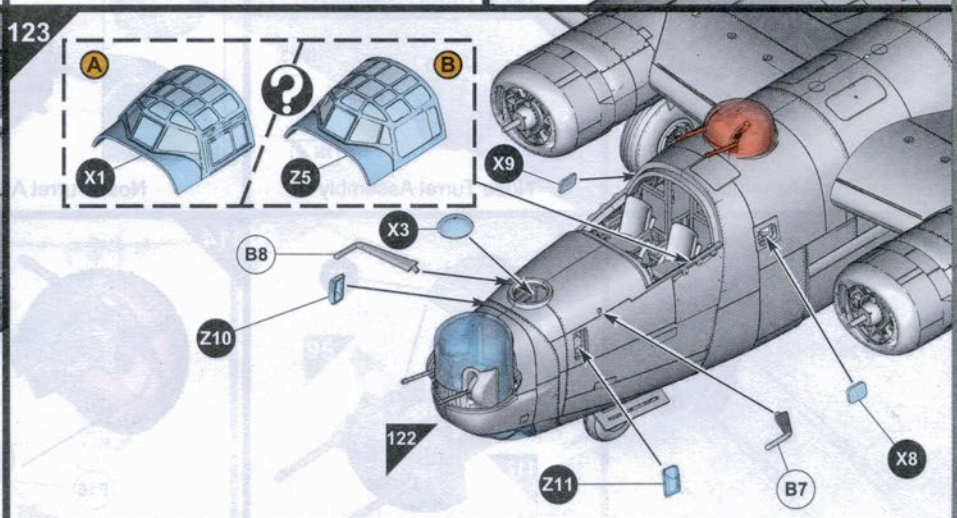
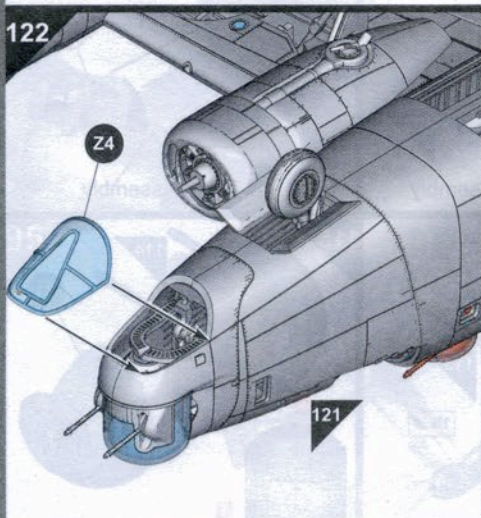
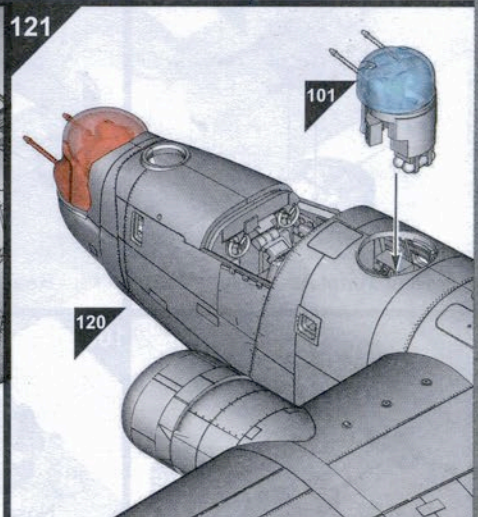
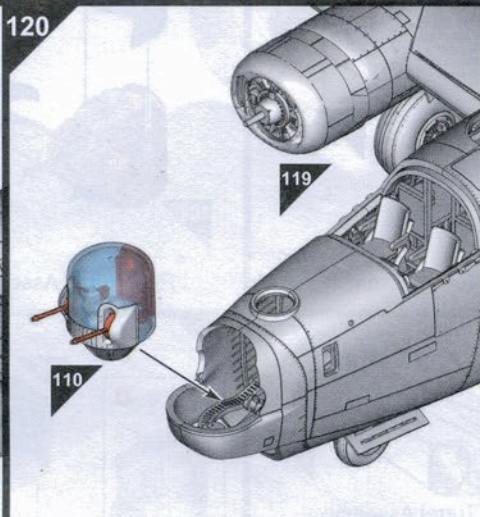
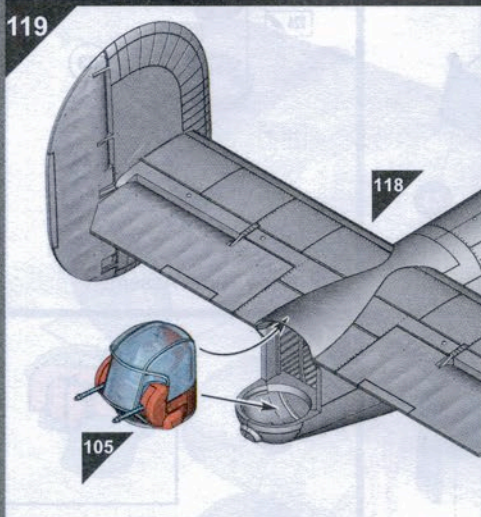
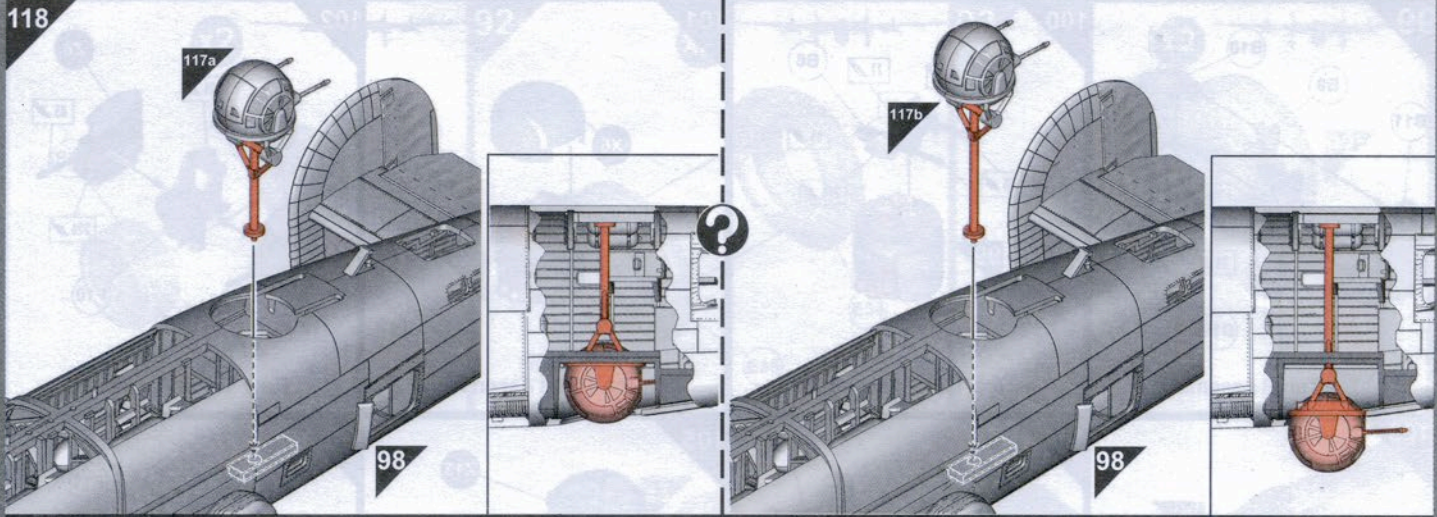

126

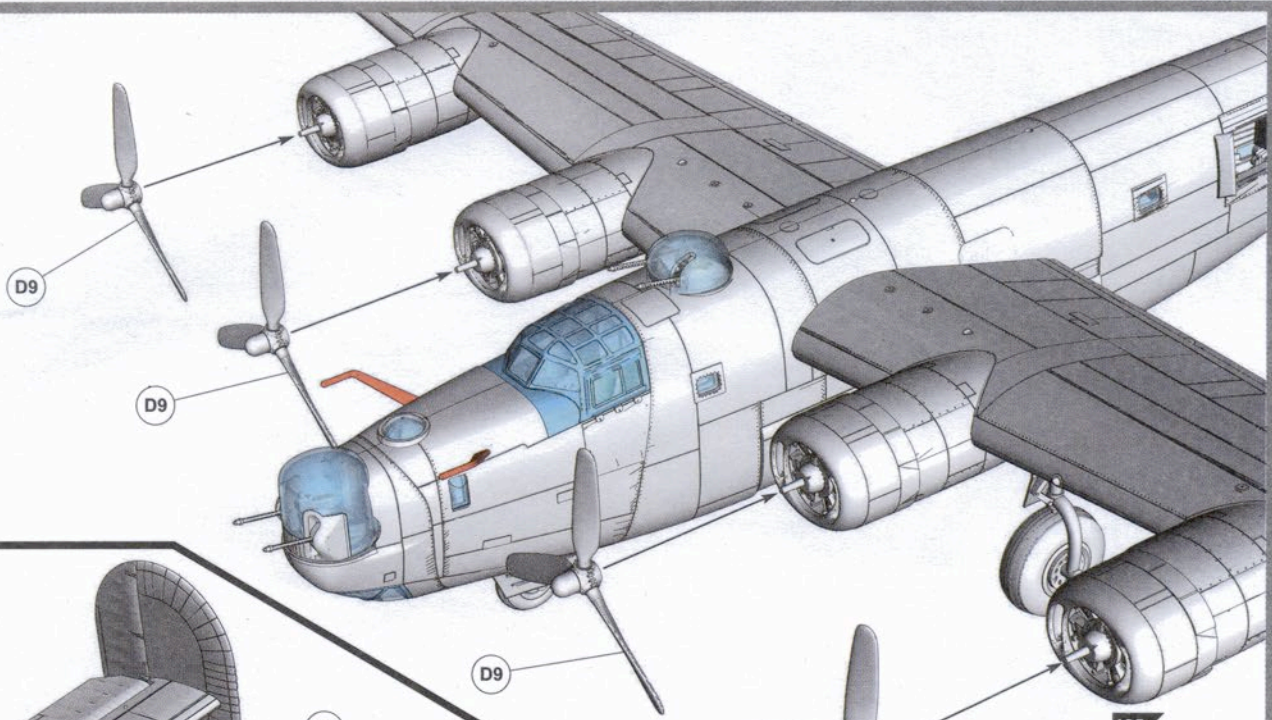

127

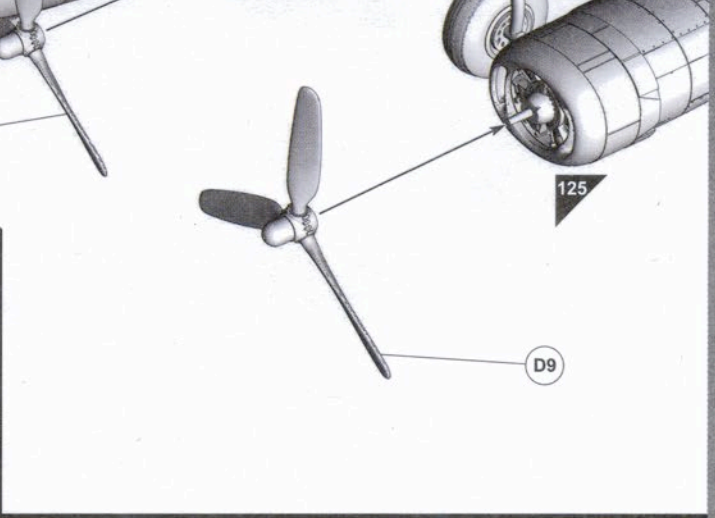
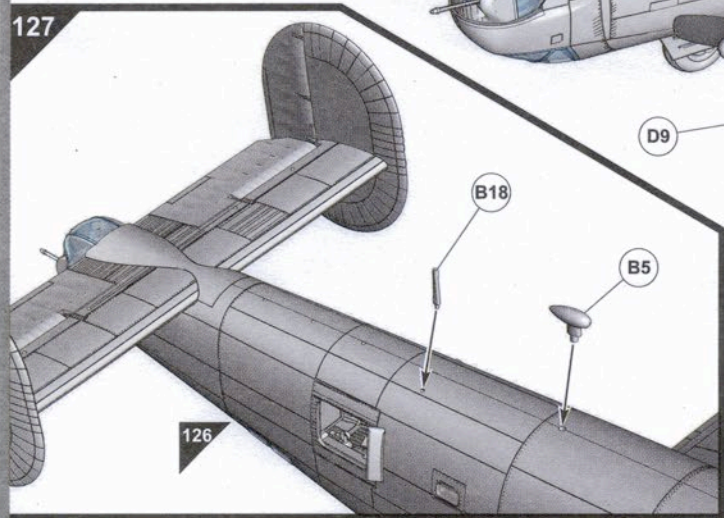

128

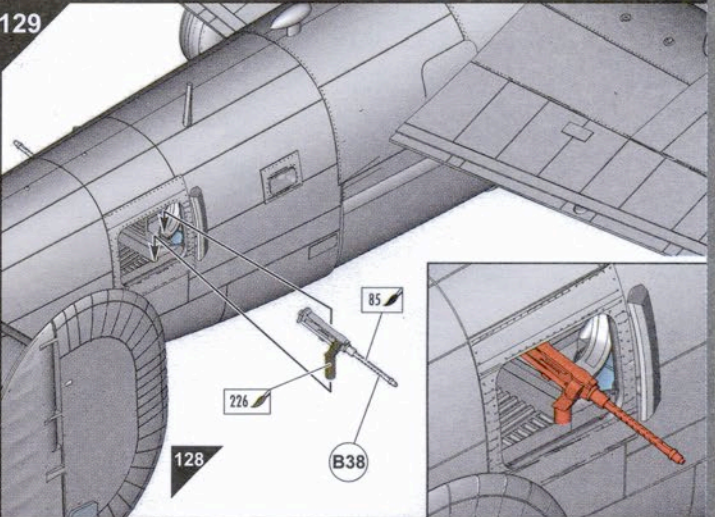
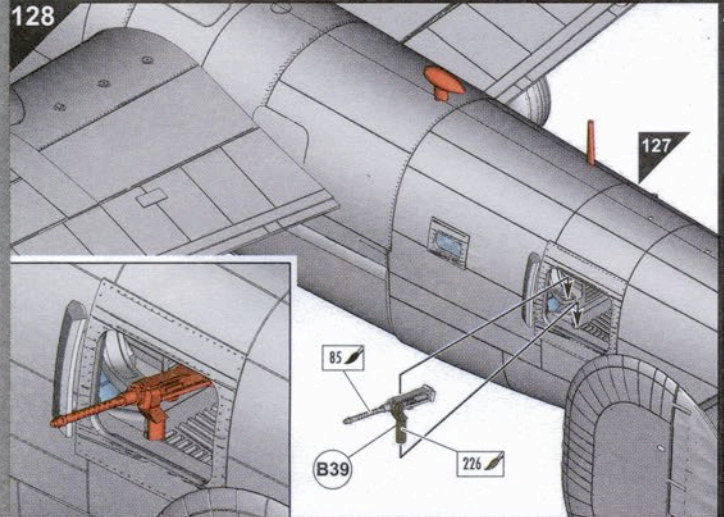

130

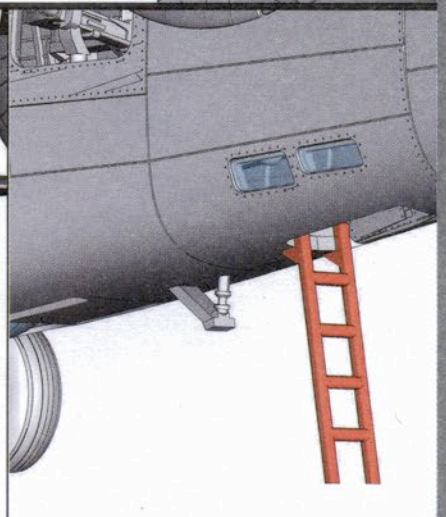
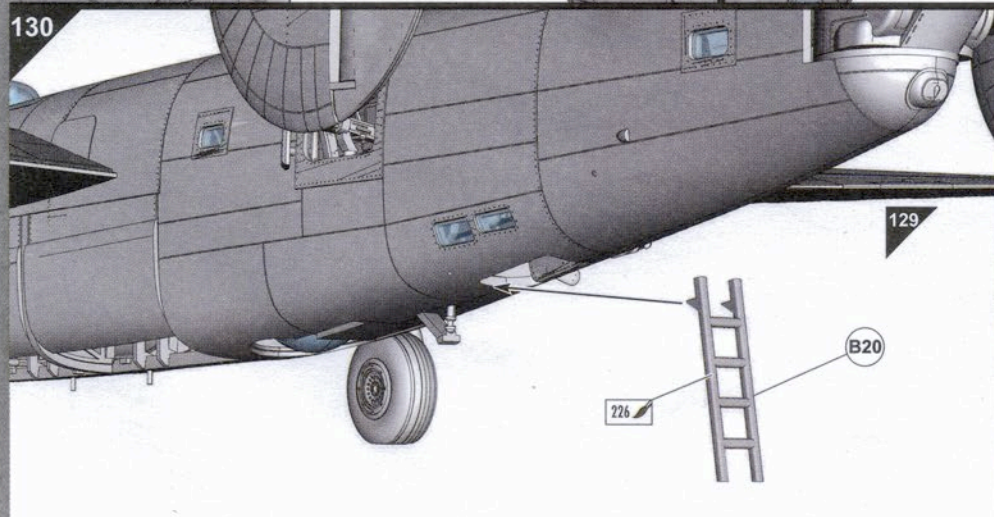

# A Consolidated B-24H-10-FO Liberator

42-52234 'Corky Burgundy Bombers', 733rd Bomb Squadron, 453rd Bomb Group, Eighth Air Force, United States Army Air Force, RAF Old Buckenham Airfield, Norfolk, England, 1944.

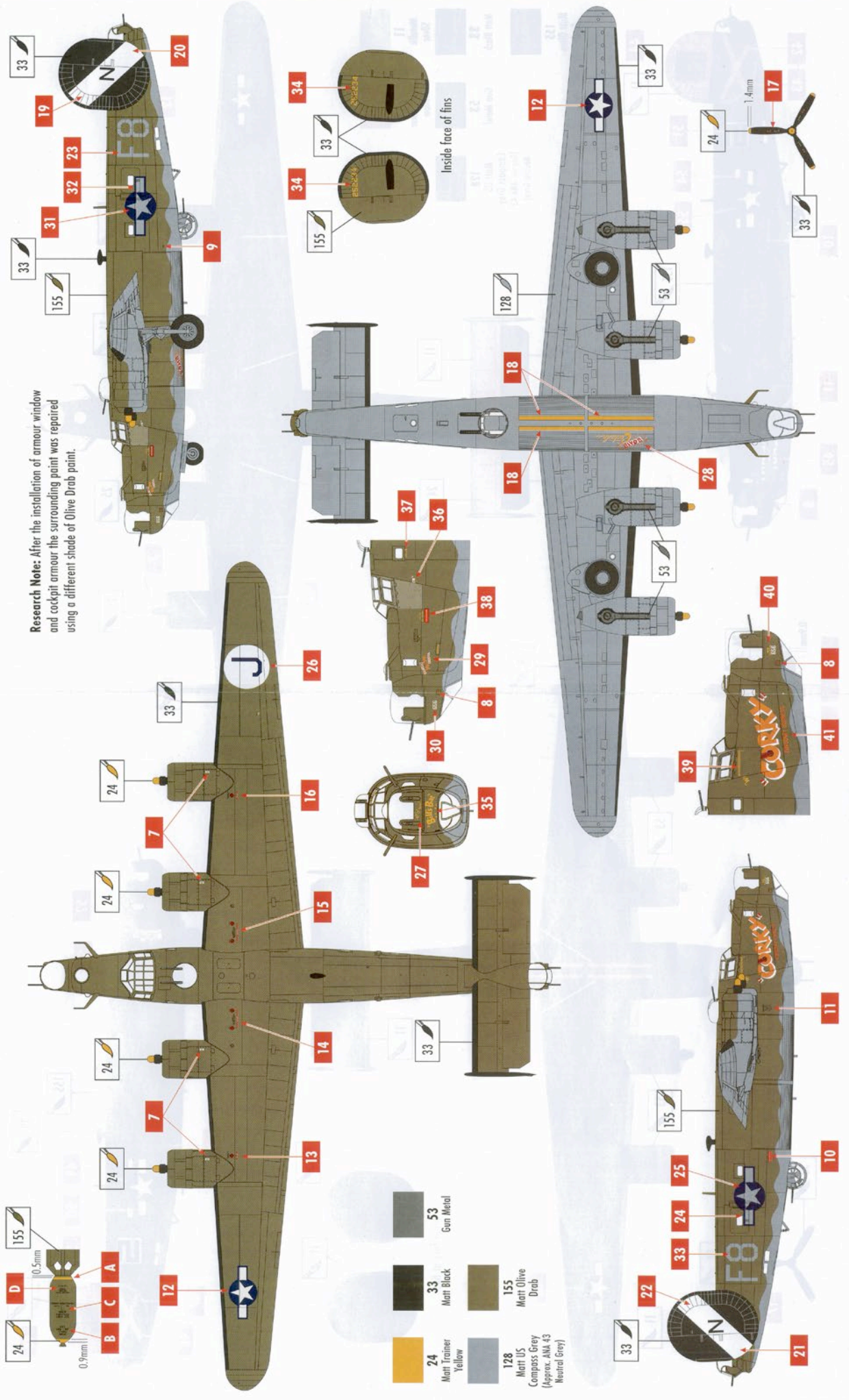

**Research Note:** After the installation of armour window and cockpit armour the surrounding paint was repaired using a different shade of Olive Drab paint.

- 24 Matt Trainer Yellow
- 33 Matt Black
- 128 Matt US Compass Grey (Approx. ANA 43 Neutral Grey)
- 53 Gun Metal
- 155 Matt Olive Drab

## B Consolidated B-24H-15-FO Liberator

42-52699 'Valiant Lady', 831st Bomb Squadron, 485th Bomb Group, Fifteenth Air Force, United States Army Air Force, Venosa, Italy, 1944.

485th Bomb Group, Venosa, Italy, 1944.

