

eduard

LIMITED
EDITION



The Bloody Hundredth 1943

INSTRUCTION SHEET

1/48

11183-NAV

The Bloody Hundredth 1943



Photo: Ernie Havecker collection

by JAN ZDIARSKY

B-17F Badger Beauty V. (42-30604) was lost on October 4, 1943, on a mission to Hanau-Saarlious, with crew of Capt. Harold B. Helstrom.

The 100th Bomb Group was one of forty similar units in the 8th Air Force. It has not established any measurable absolute dominance over any other groups during its fighting career. The unit wasn't the first to come to England, it didn't drop the most bombs, it didn't fly the most missions, it didn't even have the biggest losses, although that is often said. And yet, it was, and still is, exceptional in her legacy. After the first months of operation in Europe, it began to be called "The Bloody Hundredth". The unit you didn't want to be in as a rookie ... Although its members preferred to call themselves the "Century Bombers", with the former, less flattering moniker catching on and even adopted by many of its airmen.

The Hundredth had a reputation for unusually heavy losses over several specific missions, losses that decimated a large percentage of a particular component squadron, all but emptying the quarters that housed the crews that did not return from that mission. Understandably, the reasons for the unusual, decimating statistical fluctuations were investigated, and many of the conclusions bordered on fantasy and legend. There was talk of poor morale and discipline, insufficient training of its original crews, or the fact that the Luftwaffe just had the Hundredth in focus. Today, armed with the opportunity to look at problems from several angles, to put historical events into context, there is only one conclusion ... the unit was too often in the wrong place at the wrong time. The Bloody Hundredth was simply unlucky and bore a lot of suffering and destruction on their shoulders, which did not spread to the other units of the 8th Air Force back in the day.

The members of the Bloody Hundredth were similar to those who served in other bombing units, not exceptional in their feats, skill or courage. The uniqueness of the unit was given by a special spirit of mutual reciprocity and determination, supported by the approach of several outstanding commanders and exceptional personalities who were an inspiration to their men and became legends that set an example for those that followed. They were the legends of the Bloody Hundredth, and its "D" in a square marking, by which they recognized the planes

of their comrades on missions. The legends inspired by the four-engined B-17s and the roar of their engines, the echoes of which we can still feel today on the overgrown taxiways of their home, Thorpe Abbots Base in East England.

The 100th Bomb Group was established on June 1, 1942, in Orlando, Florida, but we can consider the place of its real birth be Boise, Idaho, where it had its first personnel attached to it. By order No. 300, 254 men were transferred here. Less than three weeks later, the unit was officially activated. Its first commander became Col. Darr Alkire. He led the unit for most of the follow-up training, until April 26, 1943, when he was replaced by Col. Howard Turner. The training, which primarily focused on group formation flying, long-range navigation flights, and bombing practice, was conducted primarily at bases in Walla Walla, Washington, Wendover Field, Utah, Sioux City, Iowa, and Kearney, Nebraska. On May 25, 1943, the thirty-five original crew members of the unit began moving overseas. They arrived in England, at a brand new base near the village of Thorpe Abbots, on June 8, 1943.

In Europe

Several officers who were to see to it that the base for the unit was ready had already moved to England at the beginning of May. Among them was the

twenty-eight-year-old Operations Officer of the 349th Squadron and the future commander of the 418th Squadron, Maj. John C. "Bucky" Egan. In addition to fulfilling some basic but necessary activities, he managed to fly two combat missions as a 'guest' of the 305th Bomb Group on May 19 and 21, 1943, during which he almost lost his life. He thus became the first aviator of the 100th Bomb Group to enter combat.

After the crews arrived with their B-17s and after their ground echelon - technical support personnel arrived by sea, the unit was able to settle into its permanent location. The commander, Howard Turner, was transferred to 1st Bomb Division Headquarters, and the new commander of the Hundredth became Col. Harold O. Huglin, with the goal of transitioning the unit into operational activity within three weeks.

The first two operational flights were referred to as "decoys". A formation of bombers was sent out to lure German fighters away from the actual attack. Although these were not easy tasks, and although they were not without danger, neither the airmen nor the unit received combat mission credit for them. The first actual bombing mission for the Hundredth came on June 25, 1943, when the unit hit submarine docks at Bremen. Already, this first mission cost three crews. Even those of the aviators who had not yet taken the war seriously realized that a trip to Europe would not be just frivolous entertainment.

It was Tuesday, August 17, 1943 ...

Combat missions quickly continued - LeMans, St. Nazaire, Le Bourget, Hamburg, Kassel, Trondheim ... Command of the unit was taken over by its first 'permanent' commander, Neil B. "Chick" Harding, who then commanded it until March 7, 1944. Bad luck seems to have taken a liking to the unit pretty soon. Losses ranged from none to one aircraft per mission, with most of the unit returning unscathed. But then came the unit's 16th mission. It was Tuesday, August 17, 1943, and the targets were the aircraft factories in Regensburg. This was the well-known "Double Strike" mission against Schweinfurt and Regensburg, for which nearly 400 B-17s from the 8th Air Force took off. At that time, the not yet "Bloody" Hundredth was placed at the end of the stream of bombers heading for Regensburg, with the intention that it would continue to North Africa after dropping its bombs. The rather unsuccessful logistics of the whole operation threw the bombers heading for Regensburg ahead of the Luftwaffe fighters. The 100th Bomb Group was punished for this severely. She lost nine crews and aircraft that day. Many of the machines that landed in Algiers were badly damaged. Later, for this mission, the unit received its first Distinguished Unit Citation (later called the Presidential Unit Citation). At the end of September, the first crew of the Hundredth completed

its operational tour of twenty-five missions. The average lifespan of B-17 aircrews for the Eighth Air Force at the time was eleven missions. However, this lucky crew ended up being the only one of the original thirty-five who came to England to celebrate the milestone!

Another two dark days for the Hundred came on the October 8 and 10, 1943, the climactic days of Black Week, when it lost 7 and 12 flying fortresses in raids on Bremen and Münster, respectively. During these two missions, the unit also lost two of its Squadron Commanders, great friends, Maj. Gale W. "Buck" Clevon and Maj. John C. "Bucky" Egan. Fortunately, both of them survived the destruction of their Fortresses and were captured. Others were not so lucky. At the same time, a new legend and inspiring personality of the Hundredth began to develop, Lt. Robert "Rosie" Rosenthal, who brought back his B-17 with only two working engines from the second of the named missions, making it the only crew to return from the mission. He was awarded the Silver Star for this, only his third combat flight, and later became commander of two squadrons and flew 52 combat missions, the most of the entire 100th Bomb Group.

Berlin!

The autumn and winter of 1943/44, often hampered by bad non-flying weather, were not a walk in the park for the unit. However, her losses did not deviate from the established averages. The turning point came in a trio of attacks on the very



Photo: Edmund G. Fokner collection

B-17F (42-3393) Just-a-Snappin', flown by crew of Lt. Everett E. Blakely after an emergency landing at RAF Ludham on their return from Bremen on October 8, 1943.

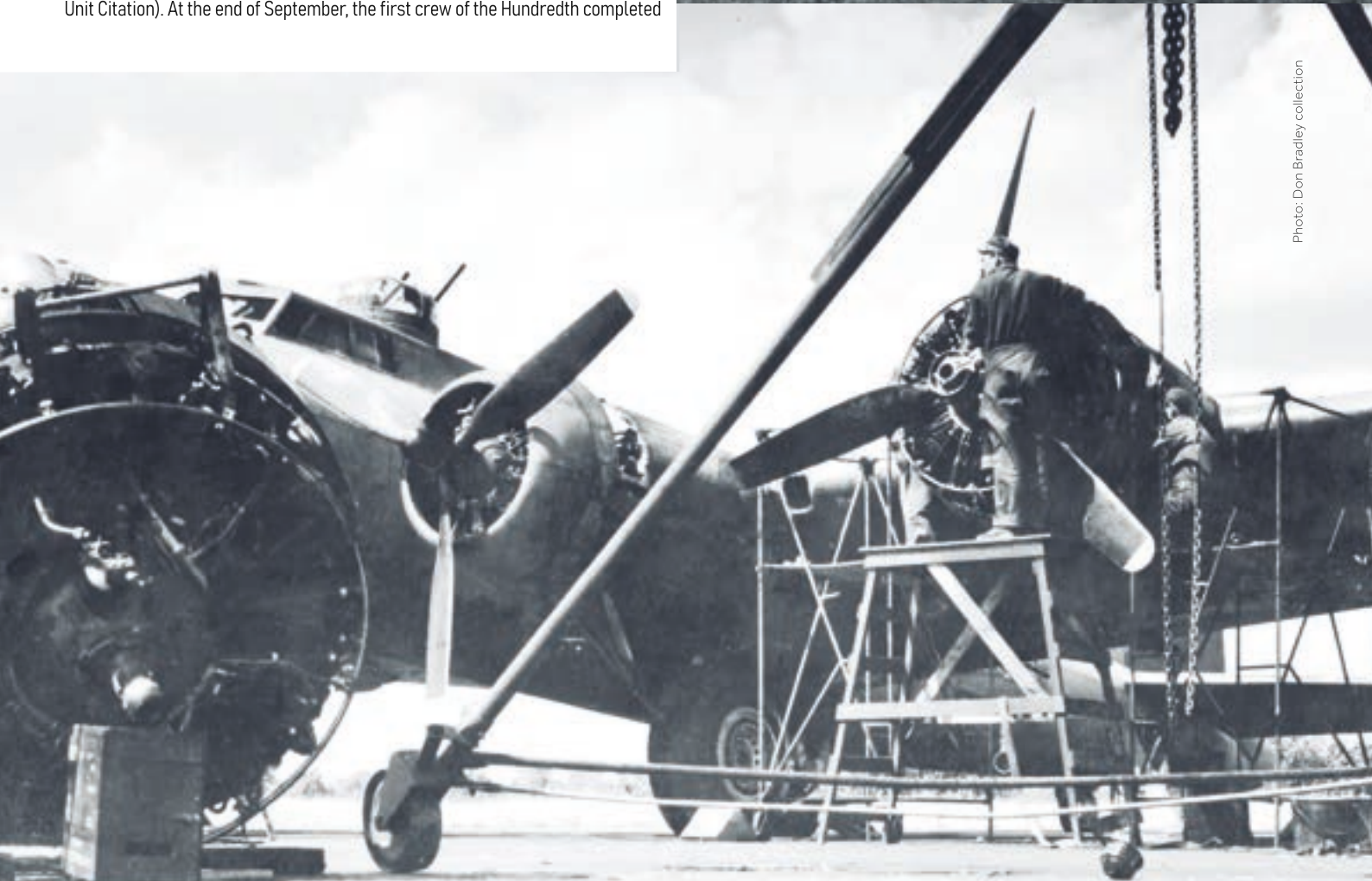

Photo: Don Bradley collection



One of the radar equipped pathfinders of the 100th Bomb Group, B-17G (44-8344) Miss Angel.



Photo: Bruce Dutton collection

heart of the Third Reich, Berlin, during the period from March 3 to 6, 1944, when the One Hundredth lost first three, then one, and then fifteen aircraft. Berlin on March 6, 1944, became the unit's most tragic mission during its existence. Despite heavy losses, the Squadron managed to accomplish the task during these missions and received the unit's second Distinguished (Presidential) Citation for its performance.

Popular Commander "Chick" Harding, who had a large part in the overall standing of the unit during these months, had to leave his post due to illness and was replaced by Col. Robert H. Kelly, who, however, was shot down during his first mission with the One Hundredth on April 28, 1944, a week after taking command. Prior to the arrival of Col. Kelly, as well as after his being downed, the unit was temporarily led by Lt. Col. John Bennett, Air Executive and Commander of the 349th Squadron.

Then, at the beginning of May 1944, came the arrival of Col. Thomas S. Jeffrey, who would remain for a significant length of time. Under his leadership, the unit participated both in the campaign against targets connected with fuel production, the so-called gasoline war, as well as in the preparation and support of the Allied landings in the western part of the continent and the opening of a second front.

B-17G (43-38514) E-Z Goin, with which the crew of Lt. Joe C. Martin returned home after being collided from behind by a German Bf 109 fighter.



Photo: Joseph A. Ciotola collection

The Battle of Fuel

On Friday, May 12, 1944, the unit took part in the 8th Air Forces first raid against industrial targets in the former Czechoslovakia. The target was Most (Brüx) and was the first of many attacks on German oil refineries in the Battle of Fuel Campaign. During the Allied landings in Normandy on June 6, 1944, The Hundredth had two combat missions to her credit that day. The third - the middle one of the day - was canceled by bad weather.

Also, the beautiful spring and summer of 1944, by when it was already clear that the war would end in favor of the Allies with their supremacy in the skies over Europe increasingly evident, saw several heavy missions and losses ... such as May 24, to Berlin, with the loss of nine aircraft; July 28 and 29, Merseburg, eleven aircraft both days; September 11, 1944, Ruhland, thirteen aircraft. The latter mission became the second most tragic for the Bloody Hundredth. That day she saw a major air battle over the Czech-German border, and although the Luftwaffe was seemingly out of breath, it was not to be the last of the great battles that awaited the unit before the end of the war.

During this period, the Hundredth also flew two Russian Shuttle missions under the codename Frantic, where the bombers would land at airfields in Ukraine after completing their mission and then return to England via 15th Air Force bases in Italy. The first took place from June 21 to July 5, 1944, the second between September 18 and 22. The second Frantic mission was aimed at dropping supplies and weapons to aid the Warsaw Uprising. It was not the Hundredth's first such operation, as the unit had previously participated in supplying the resistance movement in the south of France.

The apparent calm during the fall and early winter of 1944, when the unit flew another 45 sorties after the Ruhland mission with combat losses of seven aircraft, was shattered by the very end of the year with a raid on the refineries in Hamburg. On Sunday, December 31, 1944, The Hundredth's statistics were to fluctuate considerably again. The unexpected ferocity of Luftwaffe fighters and flak meant the loss of twelve aircraft.

In the following months, two Berlin missions, on February 3 and March 18, 1945, were among more the memorable for the Bloody Hundredth with the loss of four aircraft and their crews in each of them. With the loss of "only" two machines, the mission to Buchen on April 7, 1945, also went down in the history of the unit, with reasons for the losses being unusual for the unit. That day, some formations of American bombers were met with suicide attacks by German fighters. Even the Hundredth did not escape these attacks. In addition to two lost B-17s, there were also several that suffered serious damage, which by combination of miracle and pilot skill, managed to return home.

Germany Quits

On February 2, Col. Jeffrey was succeeded in the capacity of Commanding Officer, by Col. Jack Sutterlin. He led the unit until June 23, when he was succeeded

Photo: Don Bradley collection

The Bloody Hundredth 1943

Formation of the 100th Bomb Group over Germany



by two more Commanders, Col. John Wallace and Col Harry F. Cruver. On April 20, 1945, the 100th BG took off on its last bombing mission designated number 306. The target was Oranienburg railway station, and all returned home without loss. Base No. 139, Thorpe Abbots in Norfolk, hosted around 7,000 members of the 100th Bomb Group and its support units during the war. In 22 months of operation over the European continent, the unit lost 229 aircraft, 757 men, some of them remain missing to this day, and 923 were captured. However, the 100th Bomb Group's operations in Europe were not yet over. At the end of April 1945, many territories were still under German rule, and the guns were far from silent. A large part of the Netherlands was plagued by famine, civilians suffering from Nazi tyranny until the last days of the war. The Bloody Hundredth flew over the continent several more times. Between May 1 and 7, 1945, like other American and British bomber units, it flew a total of six Chowhound missions, during which its B-17Gs dropped food parcels in low-flying aid missions. They flew at low altitudes over the territory still occupied by German troops. However, they were warned in advance not to interfere with the bombers carrying food. In the weeks following the end of the war in Europe, the One Hundredth took part in repatriation flights for prisoners of war and conscripts of Western countries from various parts of Germany and Austria.

By the end of June 1945, almost all aircraft were flown out of the base, with the exception of some radar pathfinders. Men for whom the war was over were returning home. Part of the unit moved to Germany, where it participated in the administration of the occupation. Some of the support units involved in the partial dismantling of the base remained at Thorpe Abbots until late 1945. It then served until 1956, when it was closed and essentially forgotten. It was not until many years after the war that the thick concrete slabs and asphalt of the runways and most taxiways and hardstands were removed. The landscape returned to something resembling its original state. However, the heroism of the men who, many decades previous, took off with trepidation from here on missions over occupied Europe into horrific air battles with the sky soaked with the stench of exploding flak shells, burning gasoline, gunpowder, blood, sweat and tears, is not forgotten. It remains in the legacy of the men and women of the greatest generation, so that we can be reminded of the value of our freedom, and how much it cost. Freedom of individuals and nations. And how important it is to fight evil, even though it seems we can never completely overcome it. However, the determination and faith of the men of the Bloody Hundredth remain an inspiration.



B-17G (42-97696) Terrible Termite during POW repatriation flights in which the 100th Bomb Group participated from May 15 to June 3, 1945.

Photo: Percyk collection



Carefully read instruction sheet before assembling. When you use glue or paint, do not use near open flame and use in well ventilated room. Keep out of reach of small children. Children must not be allowed to suck any part, or pull vinyl bag over the head.



Před započatím stavby si pečlivě prostudujte stavební návod. Při používání barev a lepidel pracujte v dobře větrané místnosti. Lepidla ani barvy nepoužívejte v blízkosti otevřeného ohně. Model není určen malým dětem, mohlo by dojít k požití drobných dílů.

INSTRUCTION SIGNS * INSTR. SYMBOL * INSTRUKTION SINNBILDEN * SYMBOLES * 記号の説明



OPTIONAL
VOLBA



BEND
OHNOUT



SAND
BROUSIT



OPEN HOLE
VYVRTAT OTVOR



SYMETRICAL ASSEMBLY
SYMETRICKÁ MONTÁŽ



REMOVE
ODŘÍZNOUT



REVERSE SIDE
OTOČIT



APPLY EDUARD MASK
AND PAINT
POUŽÍT EDUARD MASK
NABARVIT

PLEASE CHECK THE LATEST VERSION OF THE INSTRUCTIONS ON www.eduard.com

PARTS



DÍLY



TEILE



PIÈCES



部品

PLASTIC PARTS

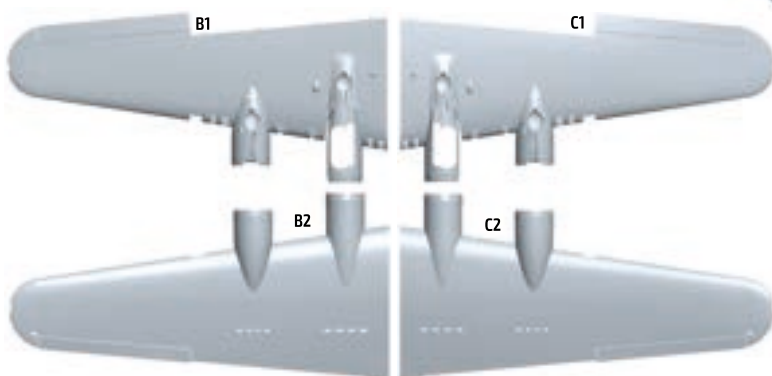

J>

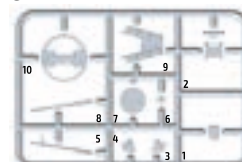

U>

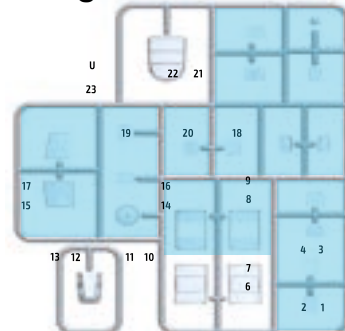

D>

E>

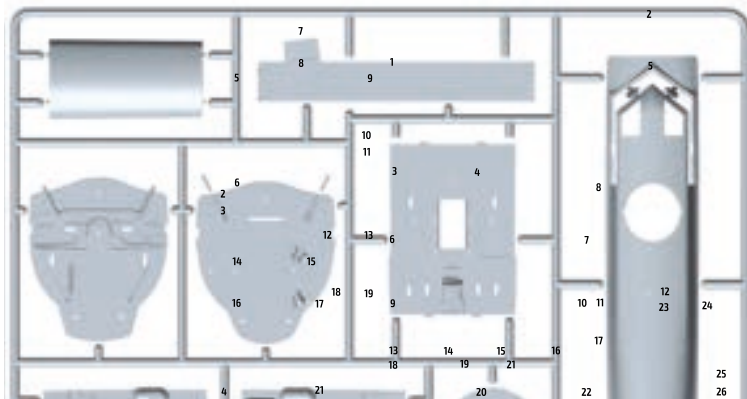

N>



L>

F>

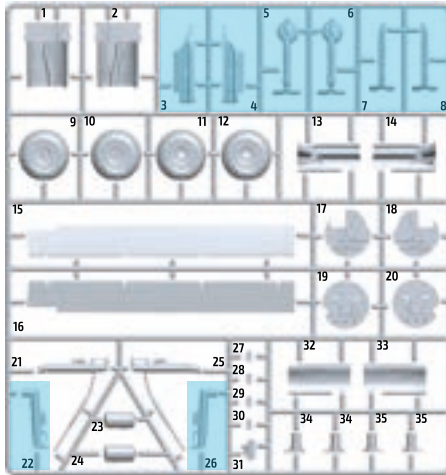

G>

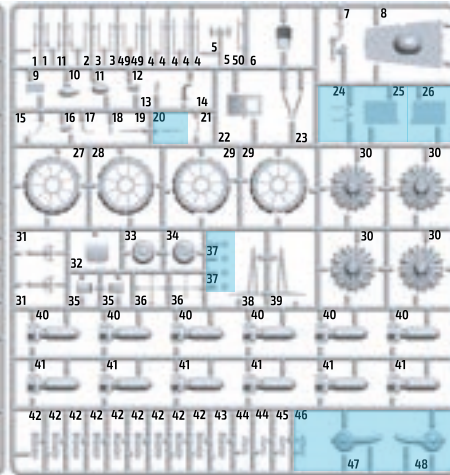

X>

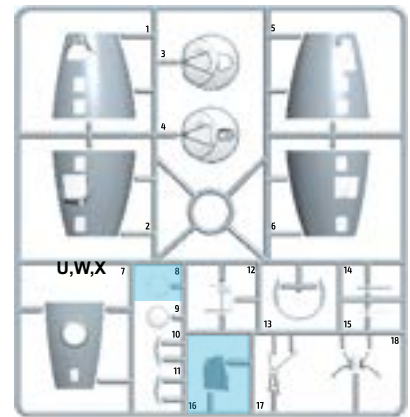

W>



V>

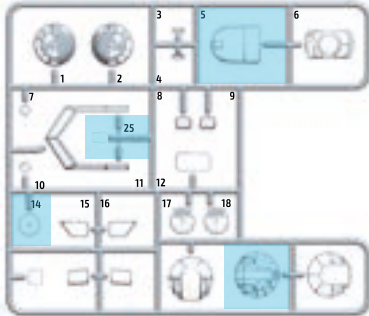

Q>

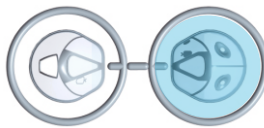

R>

I>



P>



RP - RESIN PARTS

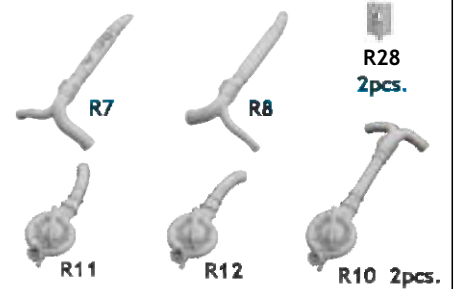

eduard MASK

PE - PHOTO ETCHED DETAIL PARTS

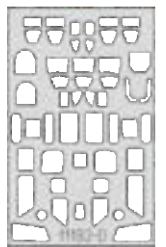
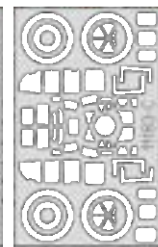
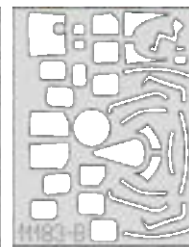
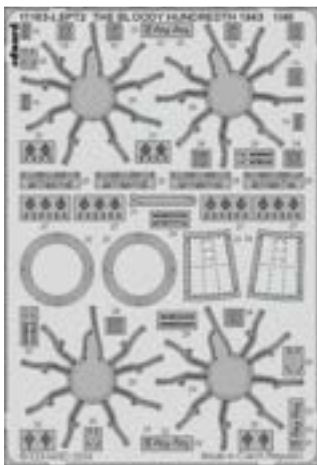

-Parts not for use. -Teile werden nicht verwendet. -Pièces à ne pas utiliser. -Tyto díly nepoužívejte při stavbě. - 使用しない部品

COLOURS



BARVY



FARBEN



PEINTURE



色

GSI Creos (GUNZE)		
AQUEOUS	Mr.COLOR	
H8	C8	SILVER
H11	C62	FLAT WHITE
H12	C33	FLAT BLACK
H37	C43	WOOD BROWN
H52	C12	OLIVE DRAB
H53	C13	NEUTRAL GRAY
H58	C351	INTERIOR GREEN
H77	C137	TIRE BLACK
H78	C38	OLIVE GREEN
H79	C39	SAND YELLOW
H94	C138	CLEAR GREEN
H90	C47	CLEAR RED

GSI Creos (GUNZE)		
AQUEOUS	Mr.COLOR	
H327	C327	RED
H329	C329	YELLOW
H331	C331	DARK SEAGRAY
Mr.METAL COLOR		
MC211		CHROME SILVER
MC213		STEEL
MC214		DARK IRON
MC218		ALUMINIUM
MC219		BRASS
Mr.COLOR SUPER METALLIC		
SM201		SUPER FINE SILVER

INTERIOR COLOR - BARVA INTERIÉRU

INTERIOR

90% + 10%

H53
C351
INTERIOR
GREEN

H12
C33
FLAT BLACK

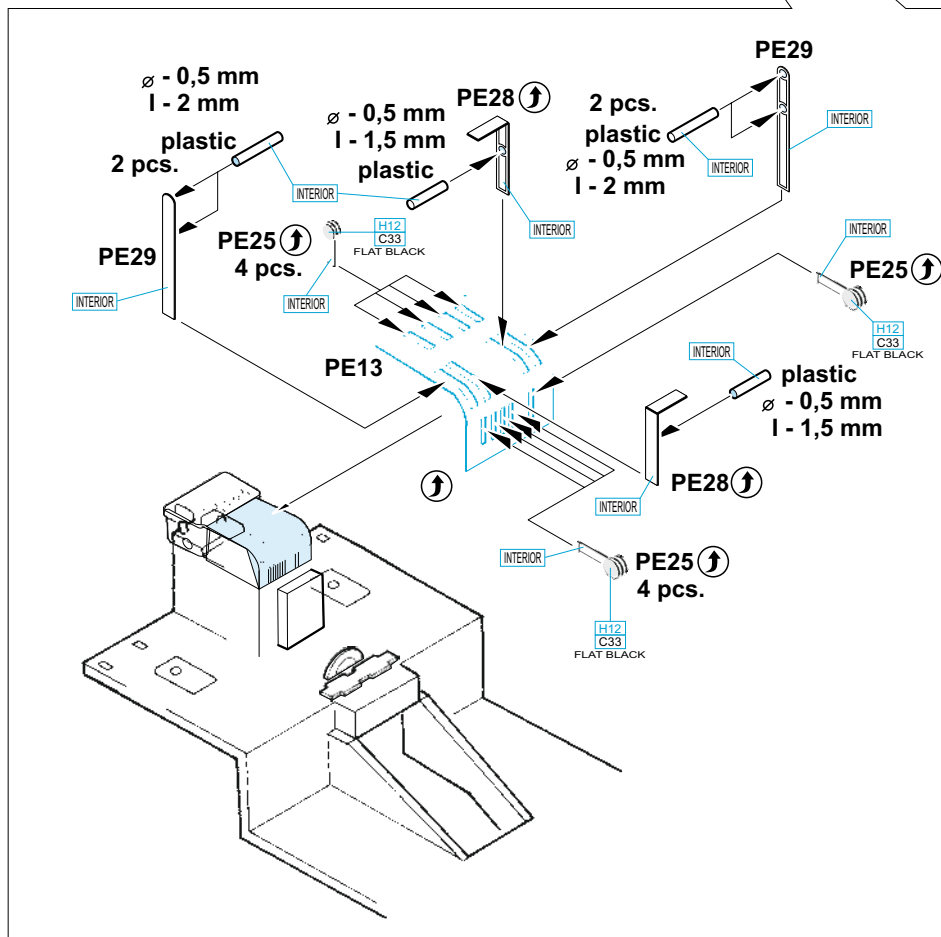
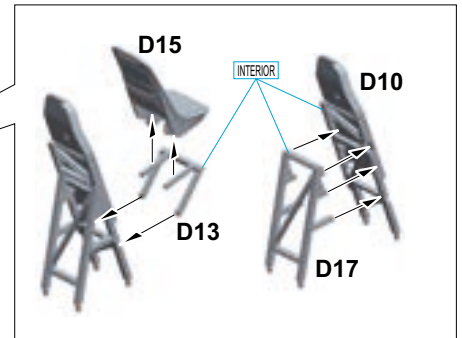
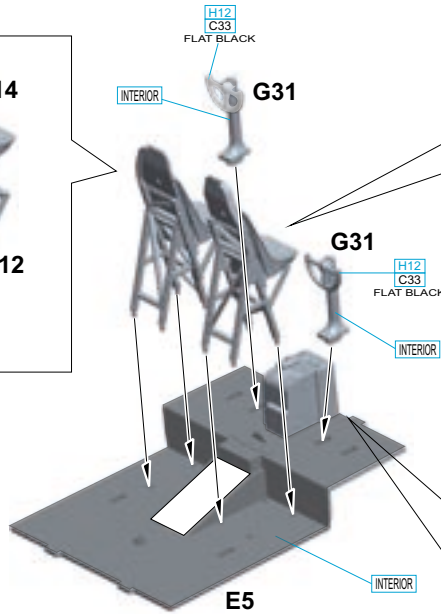
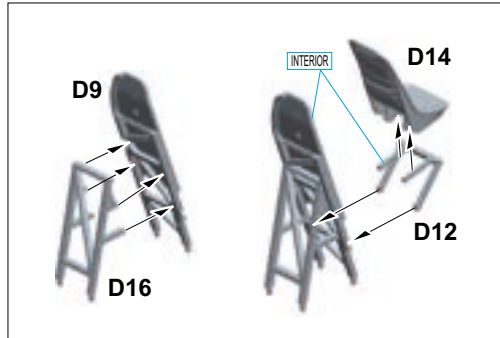
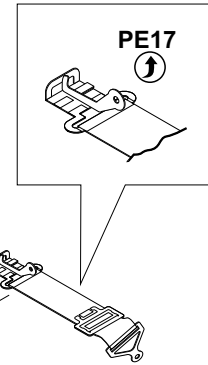
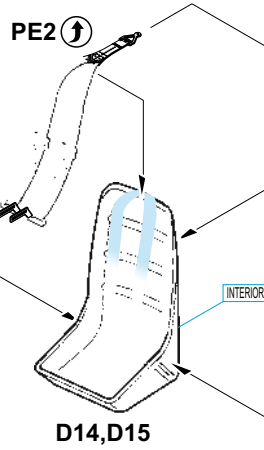
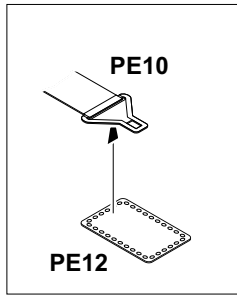

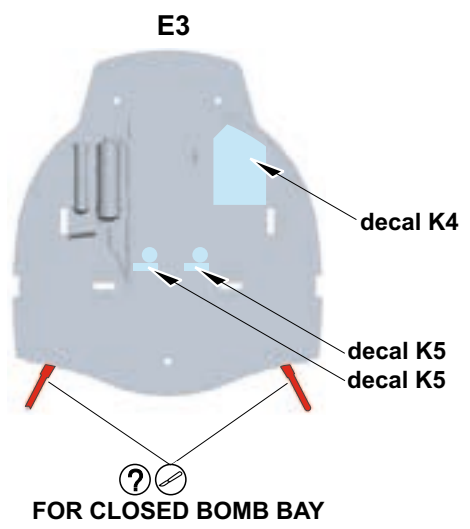
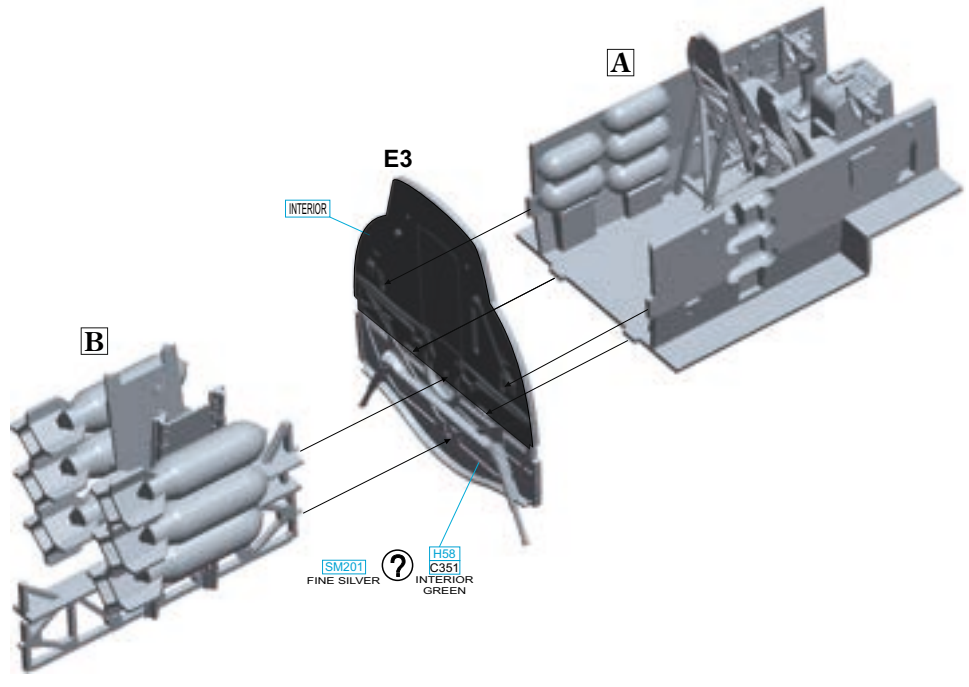
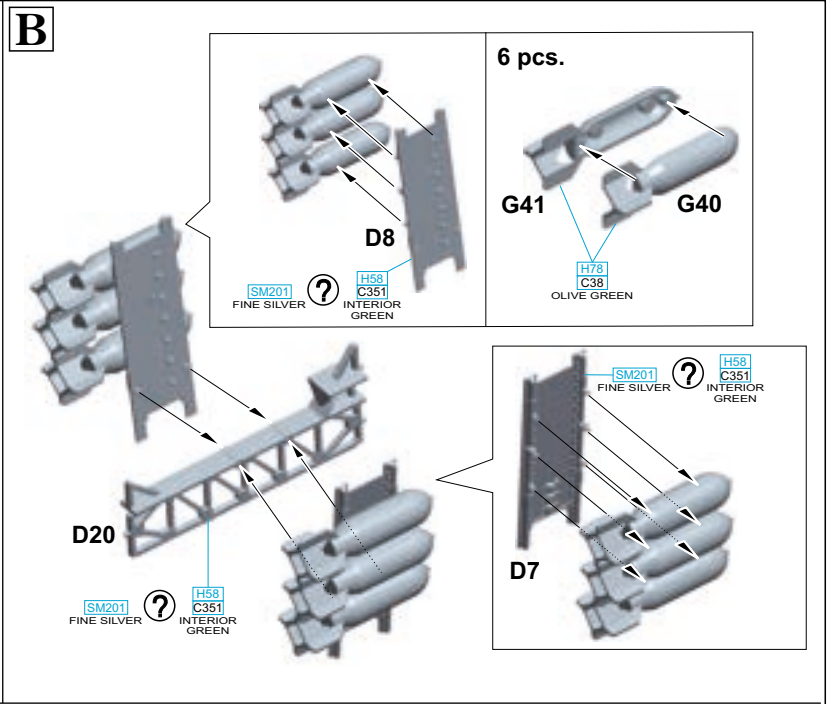
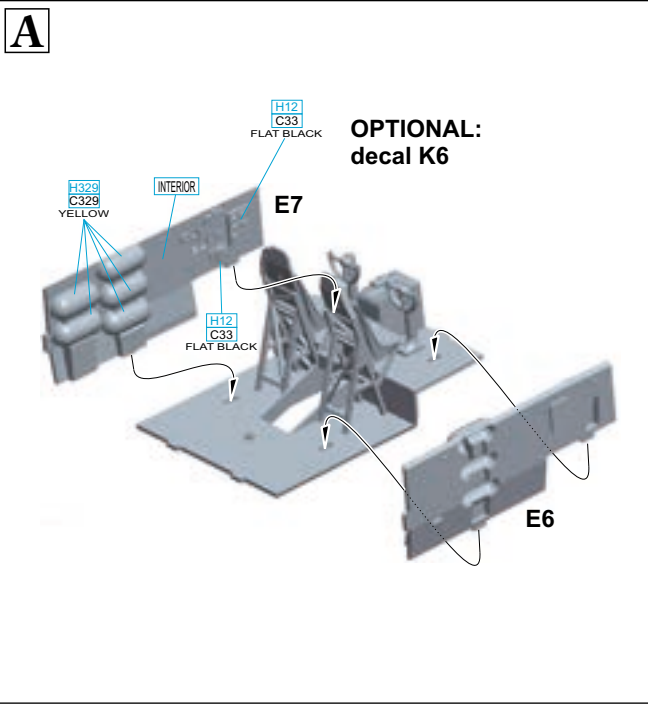

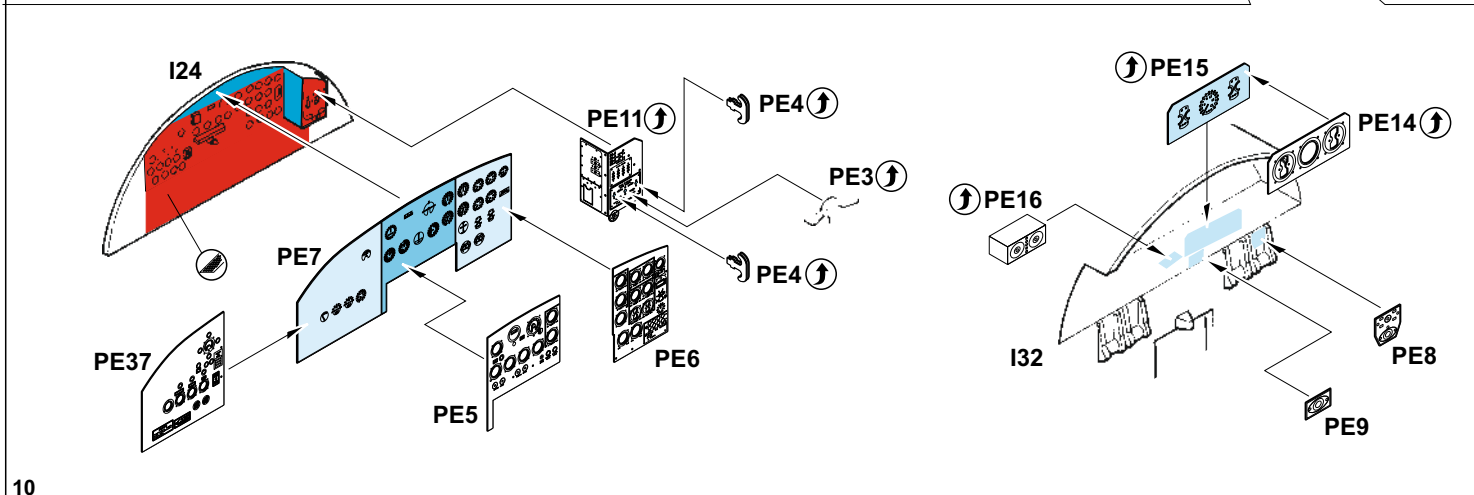
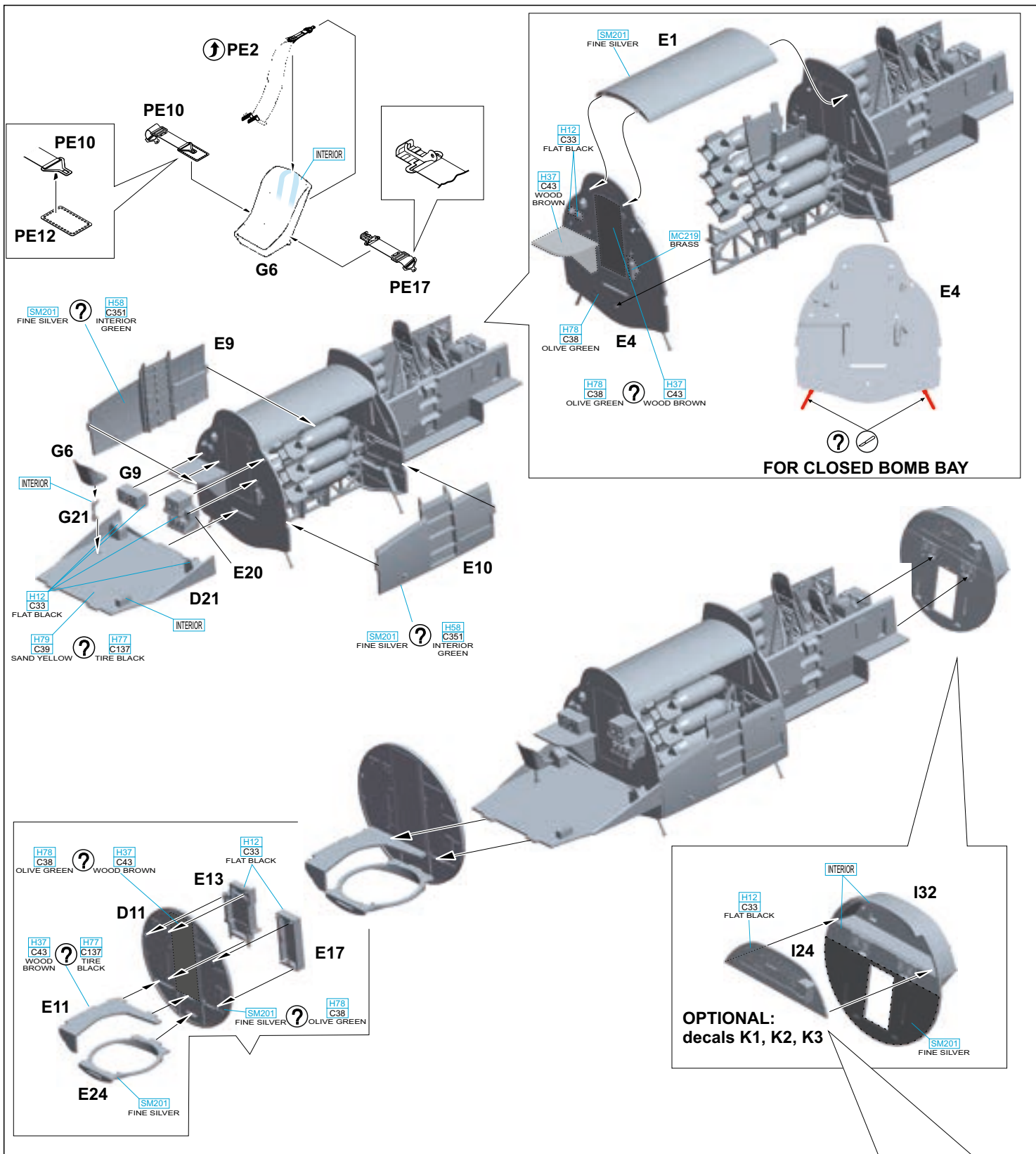

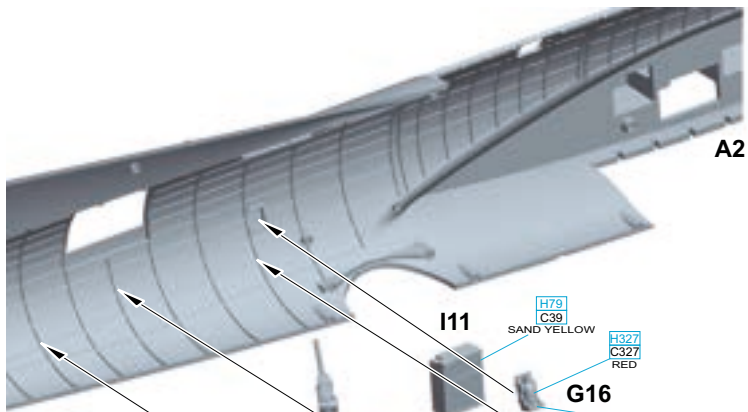

A2

I11 H79 C39 SAND YELLOW
 G16 H327 C327 RED
 SM201 FINE SILVER

I30

H79 C39 SAND YELLOW

H77 C137 TIRE BLACK

I14

MC214 DARK IRON

SM201 FINE SILVER

I33

I14

MC214 DARK IRON

MC218 ALUMINIUM

I33

2 pcs.

PE24

PE23



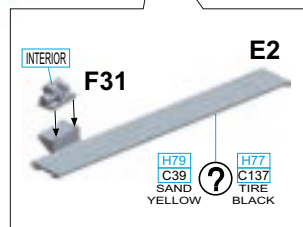
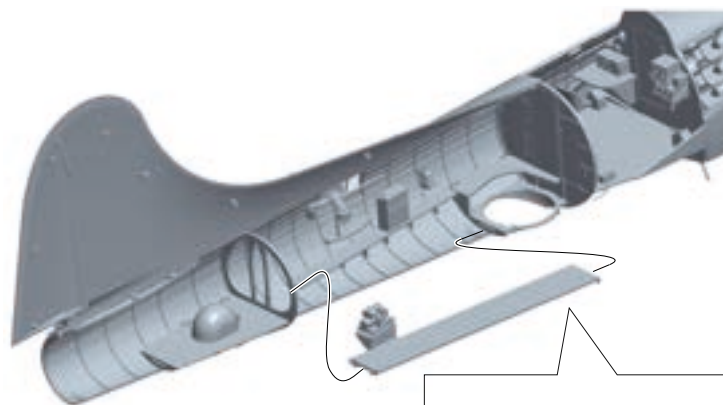
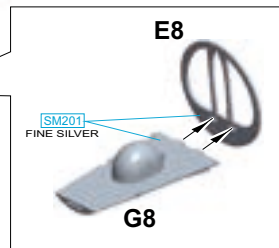
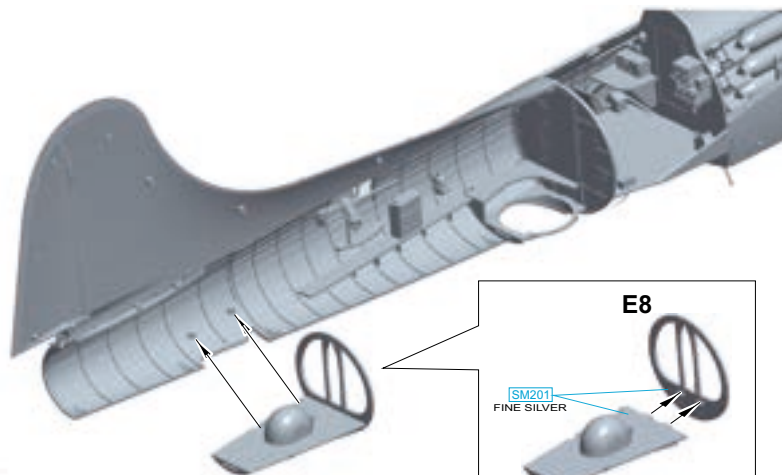
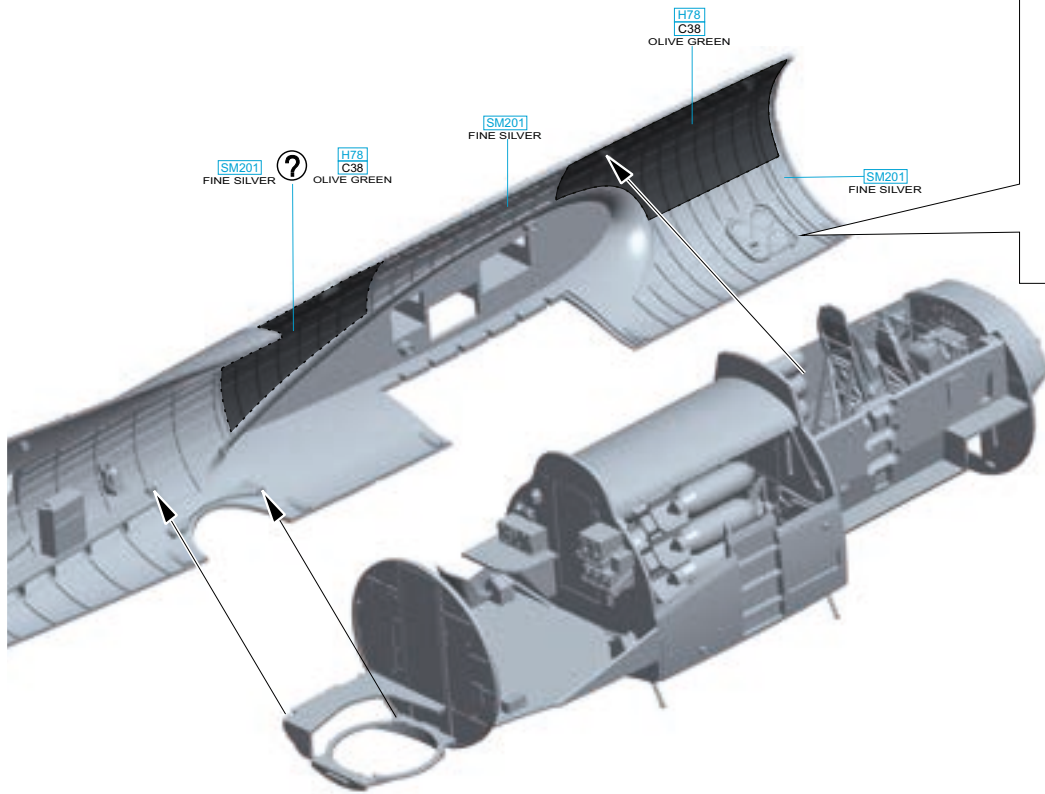

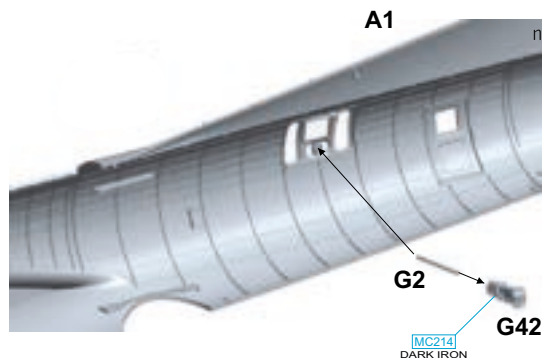
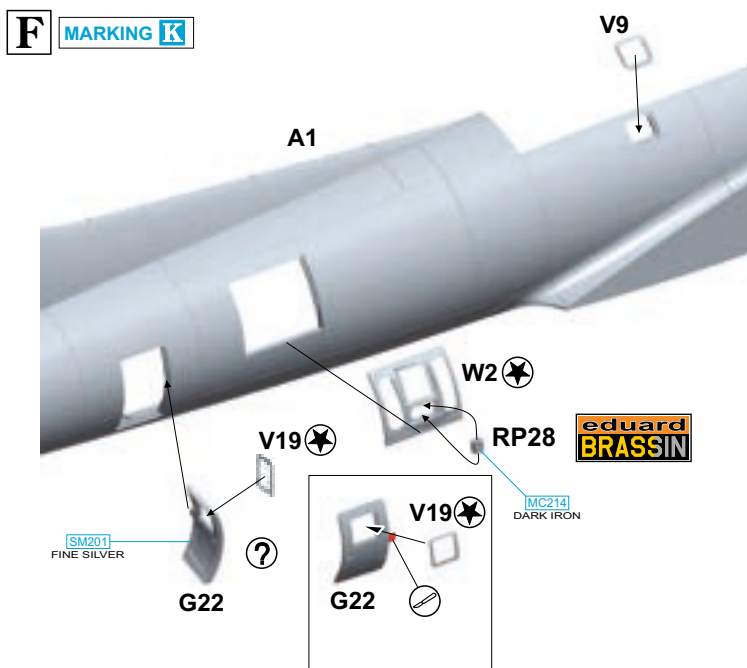
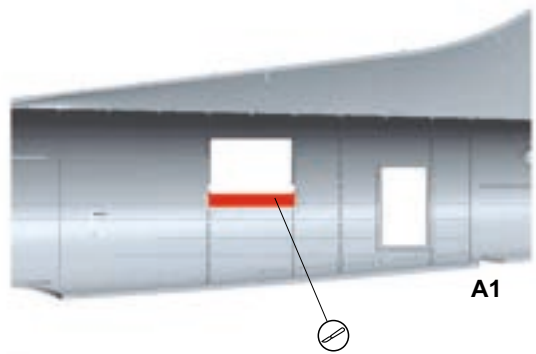
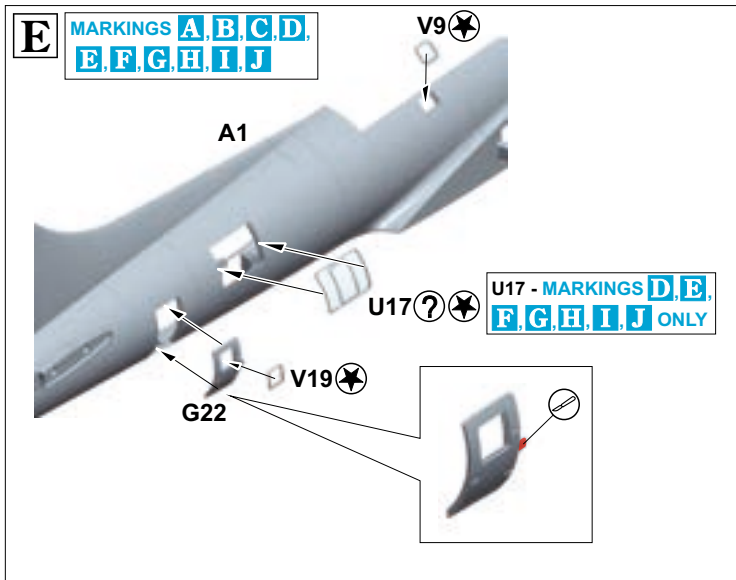
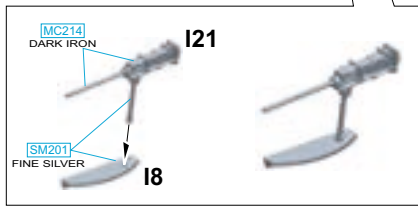
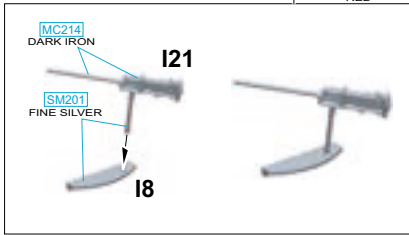
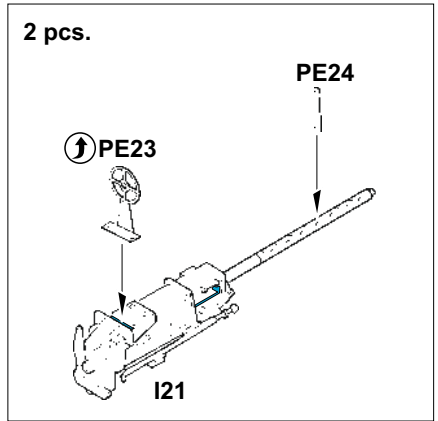
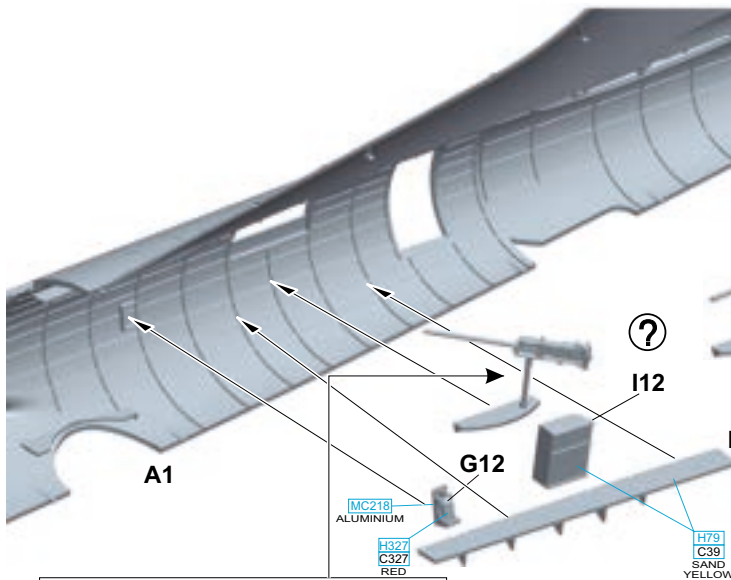

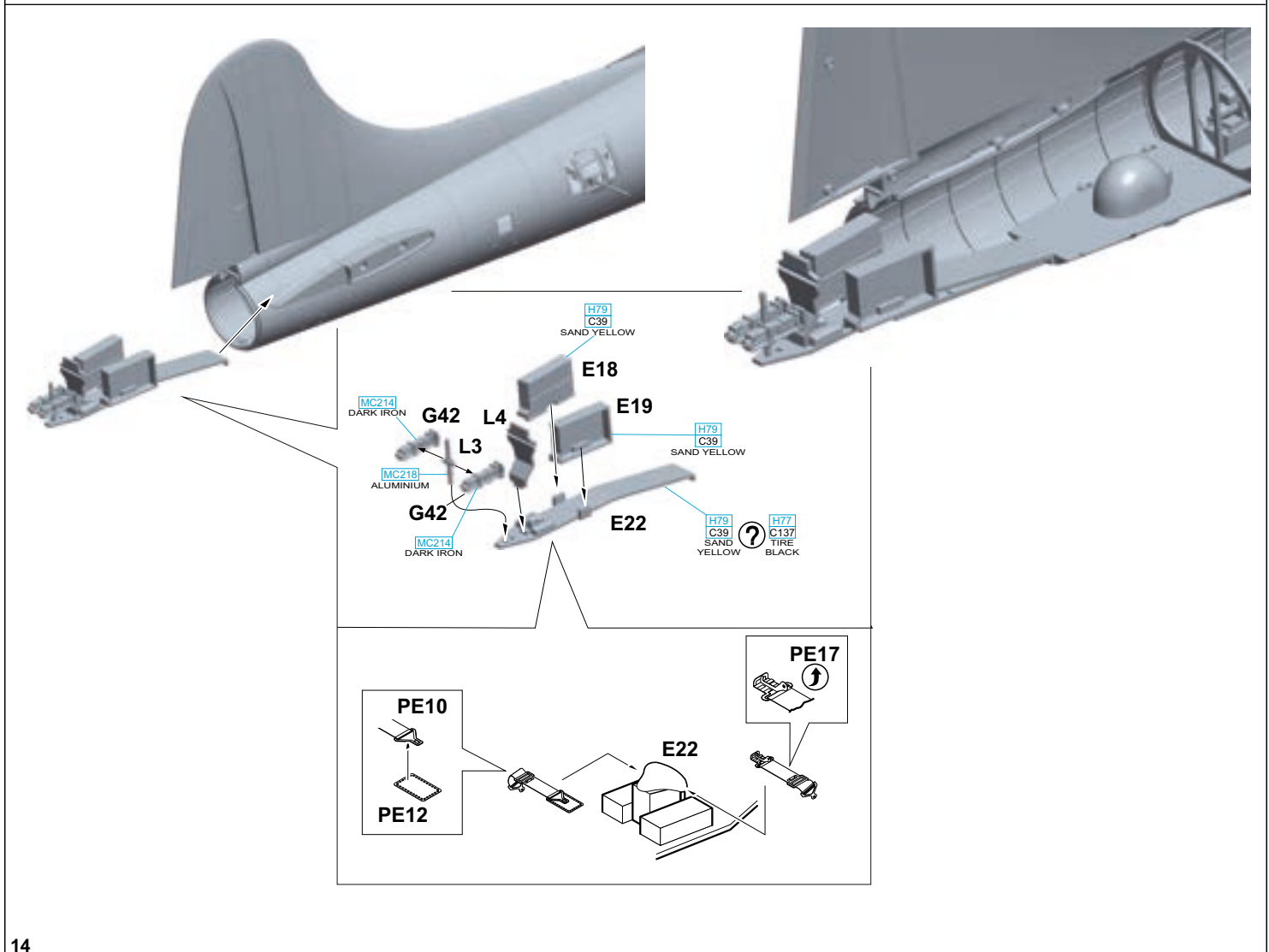
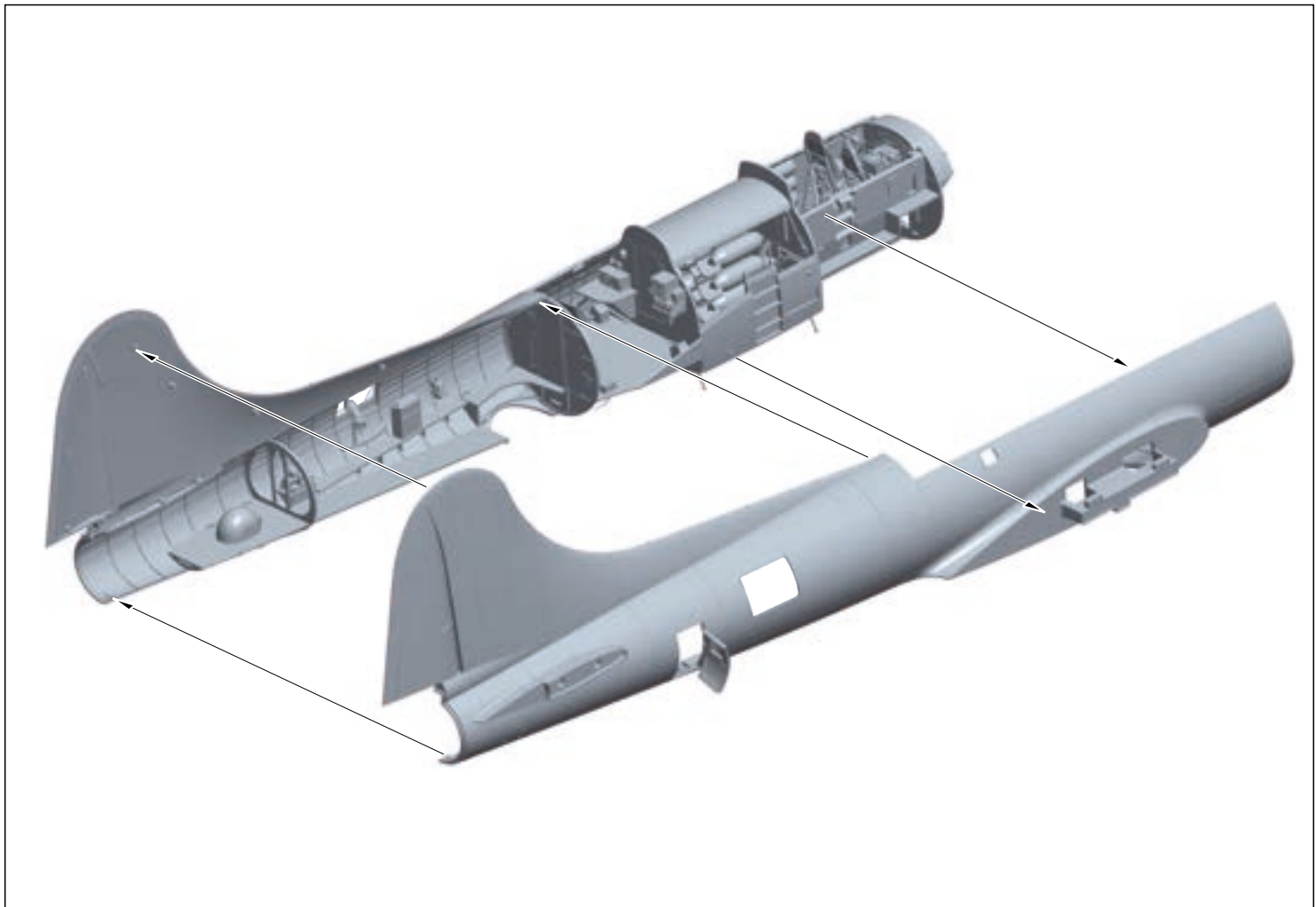

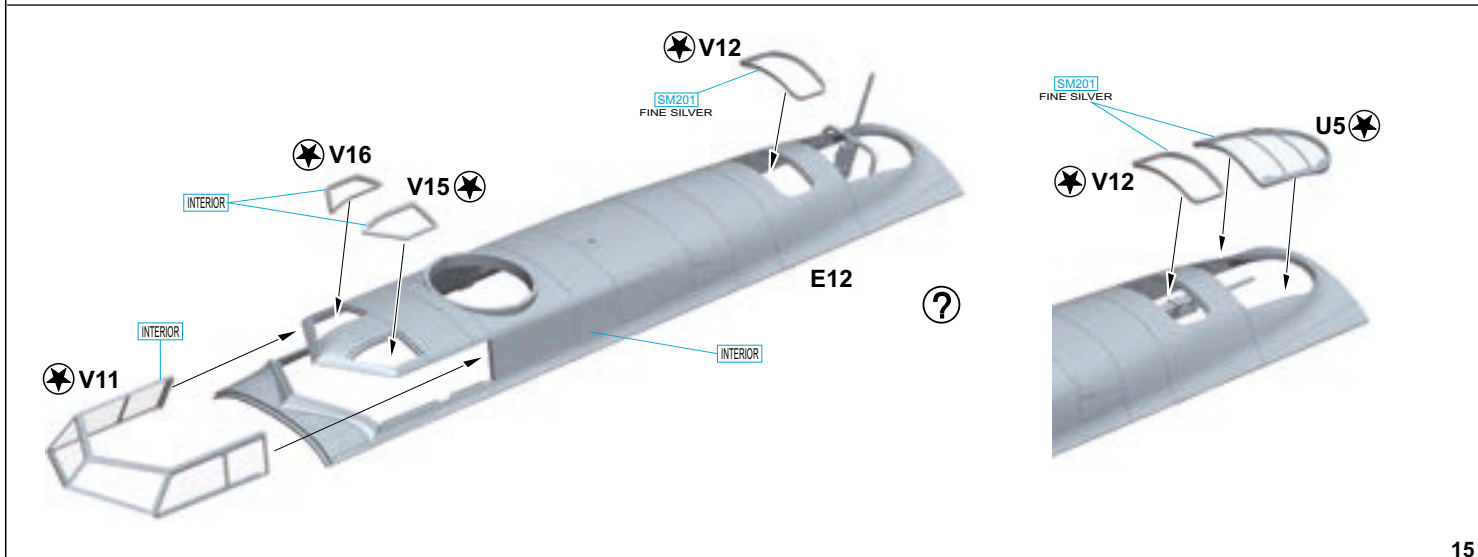
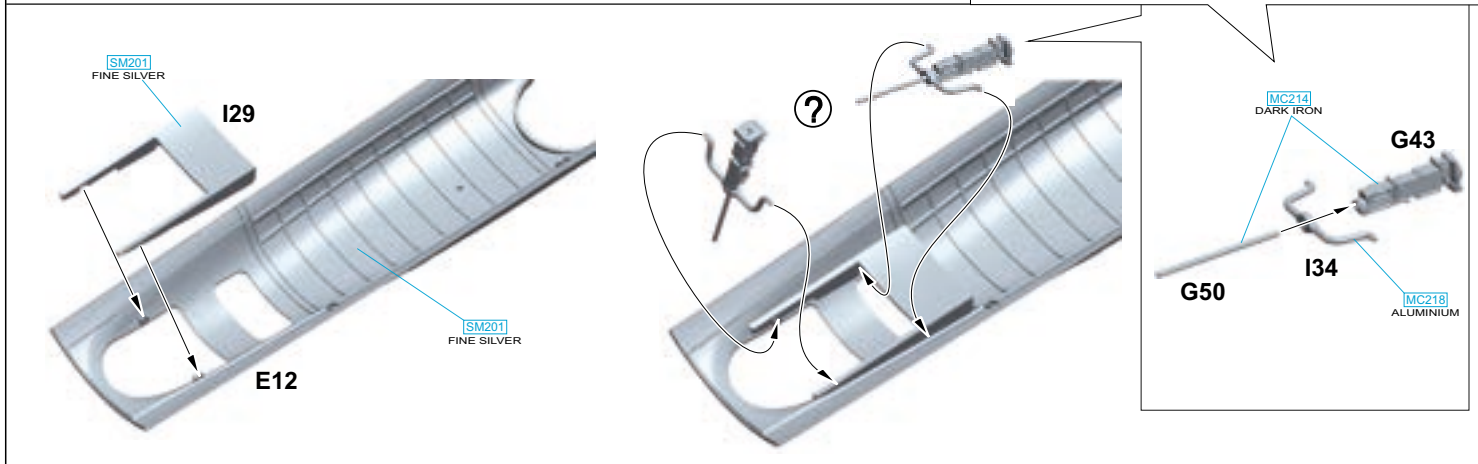
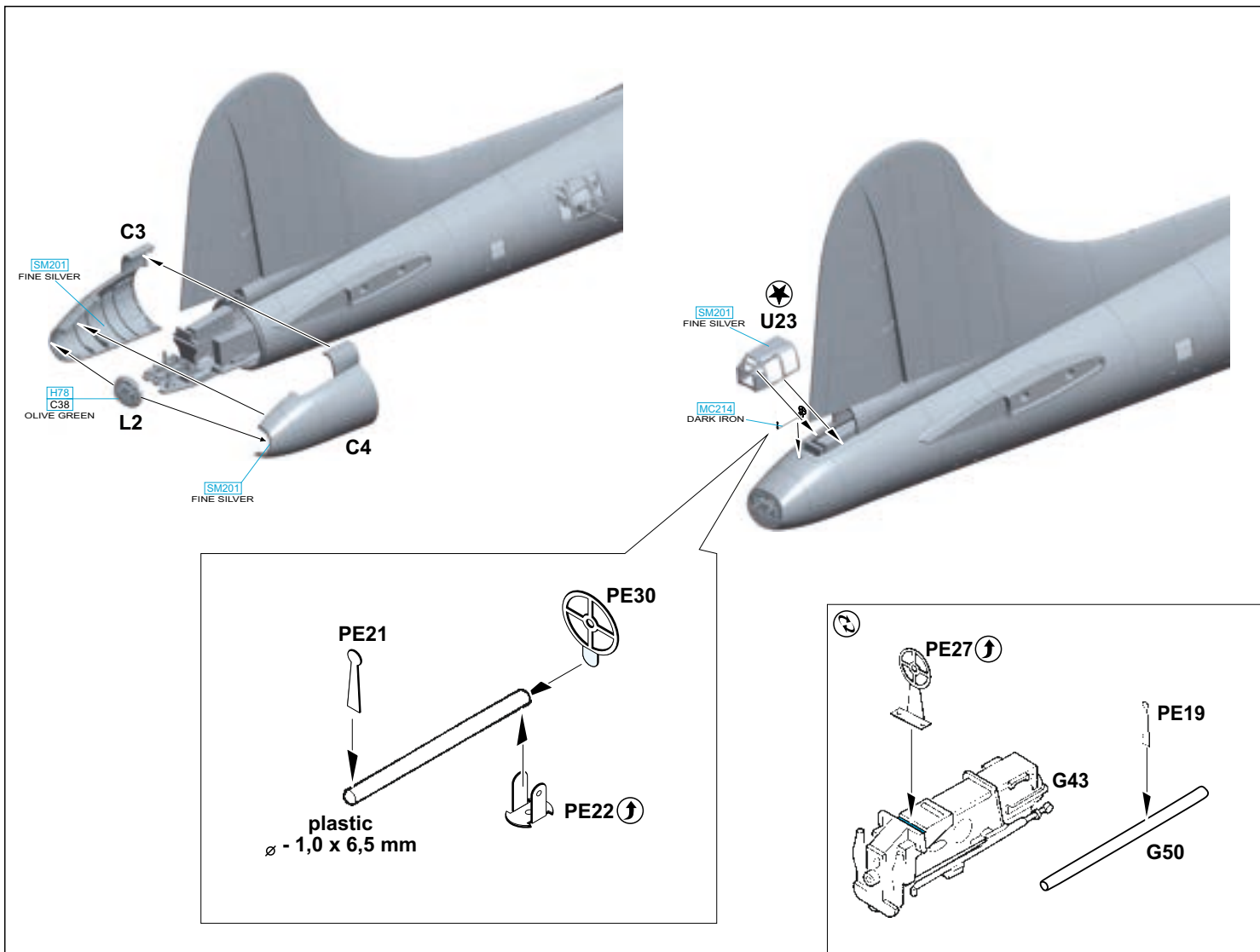

G MARKINGS A,B,C

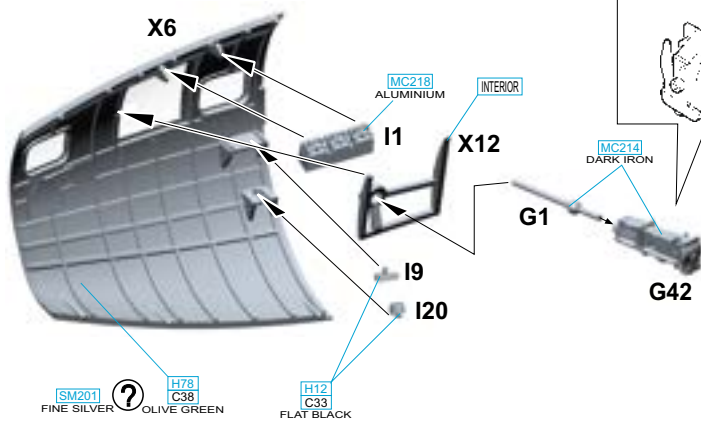

H MARKINGS A,B,C

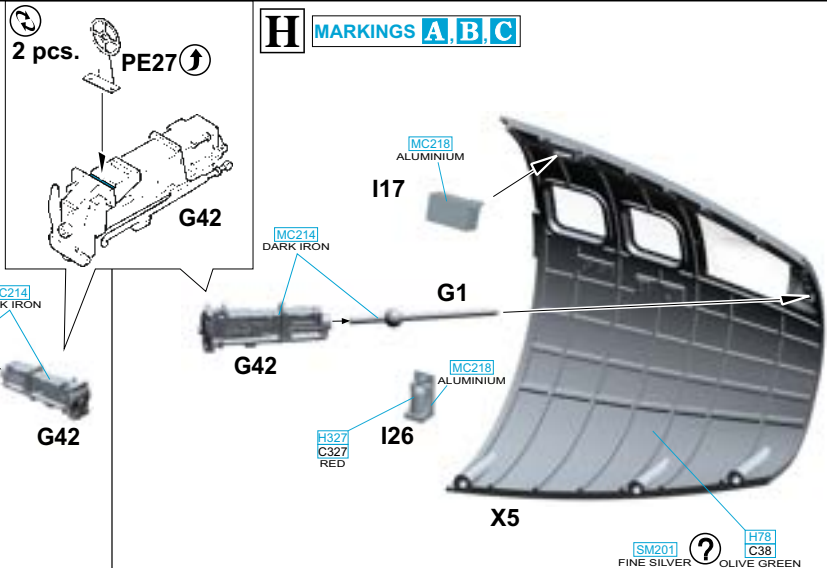

I MARKINGS D,E,F,G,H,I,J,K

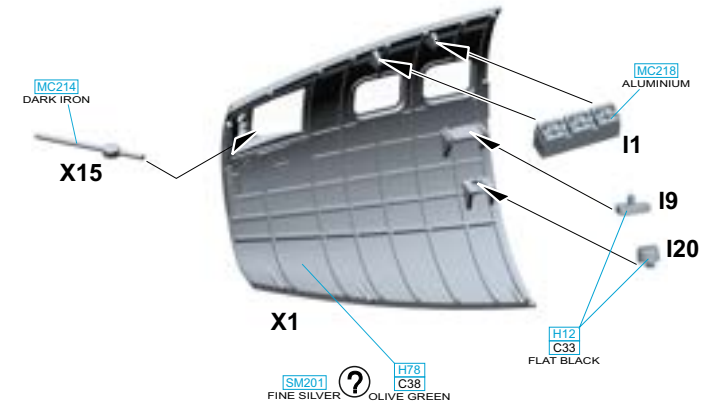

J MARKINGS D,E,F,G,H,I,J,K

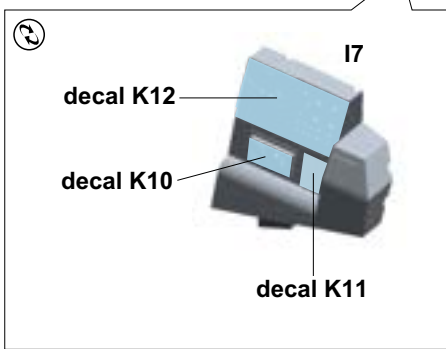
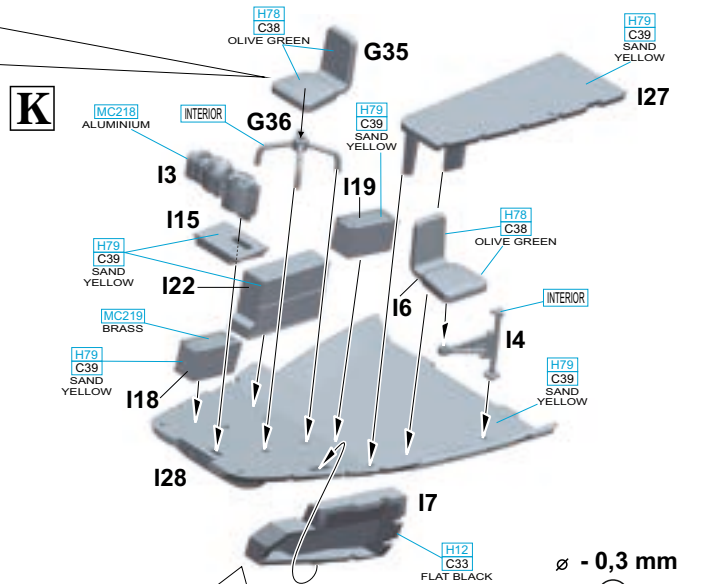
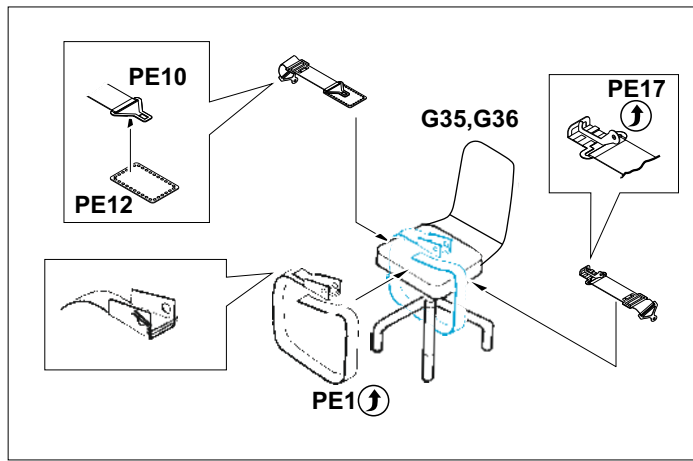
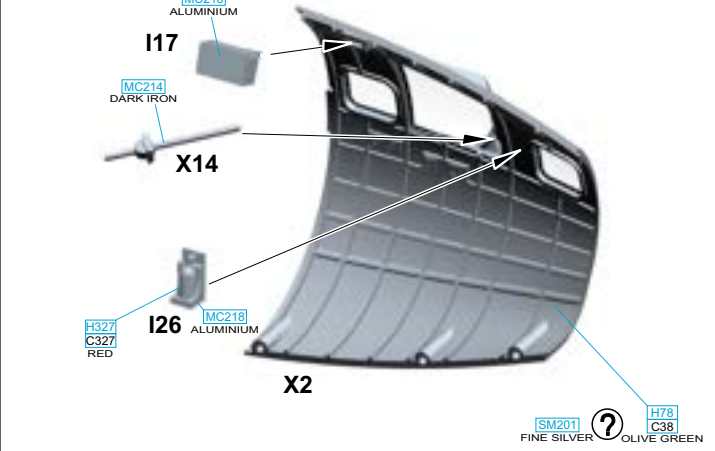

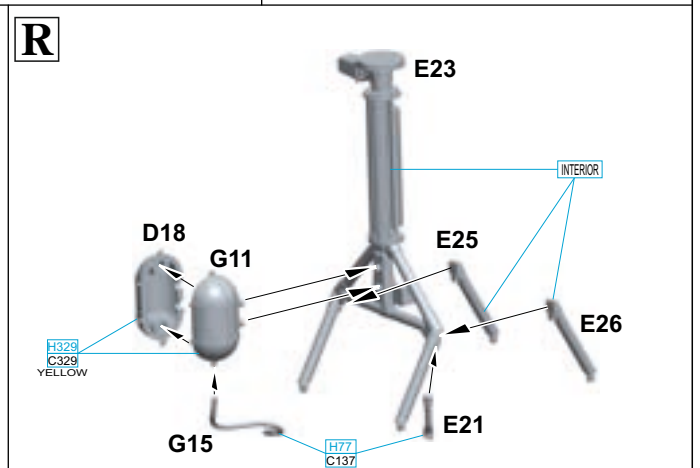
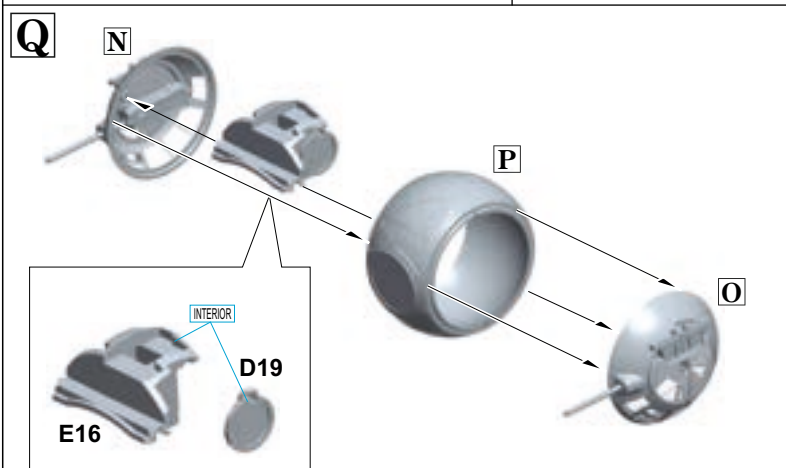
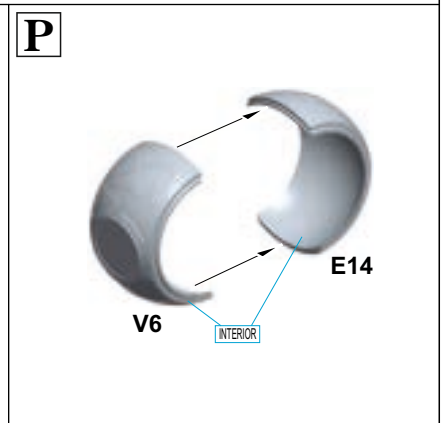
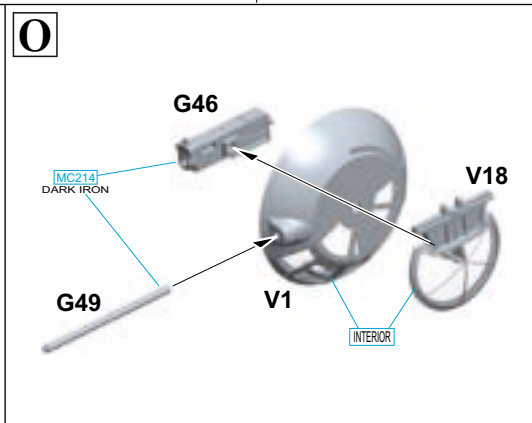
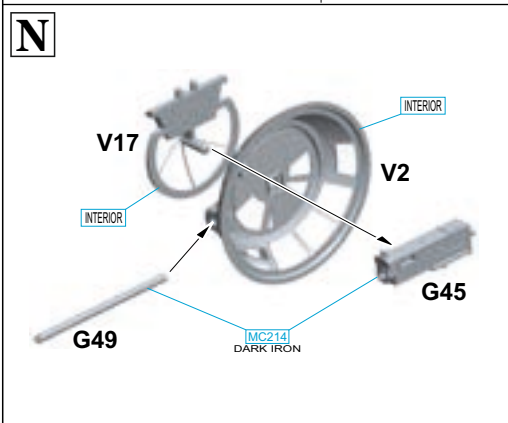
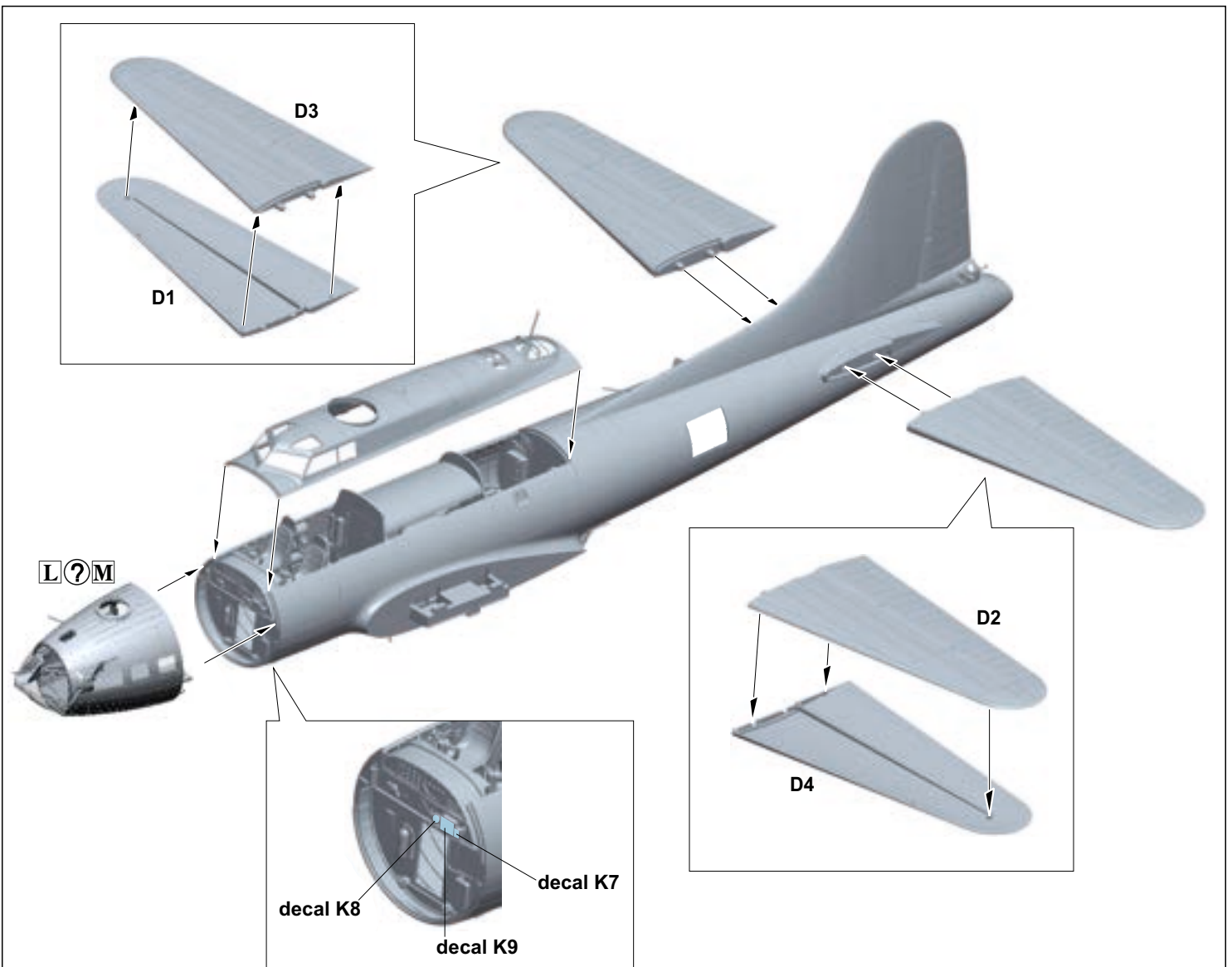

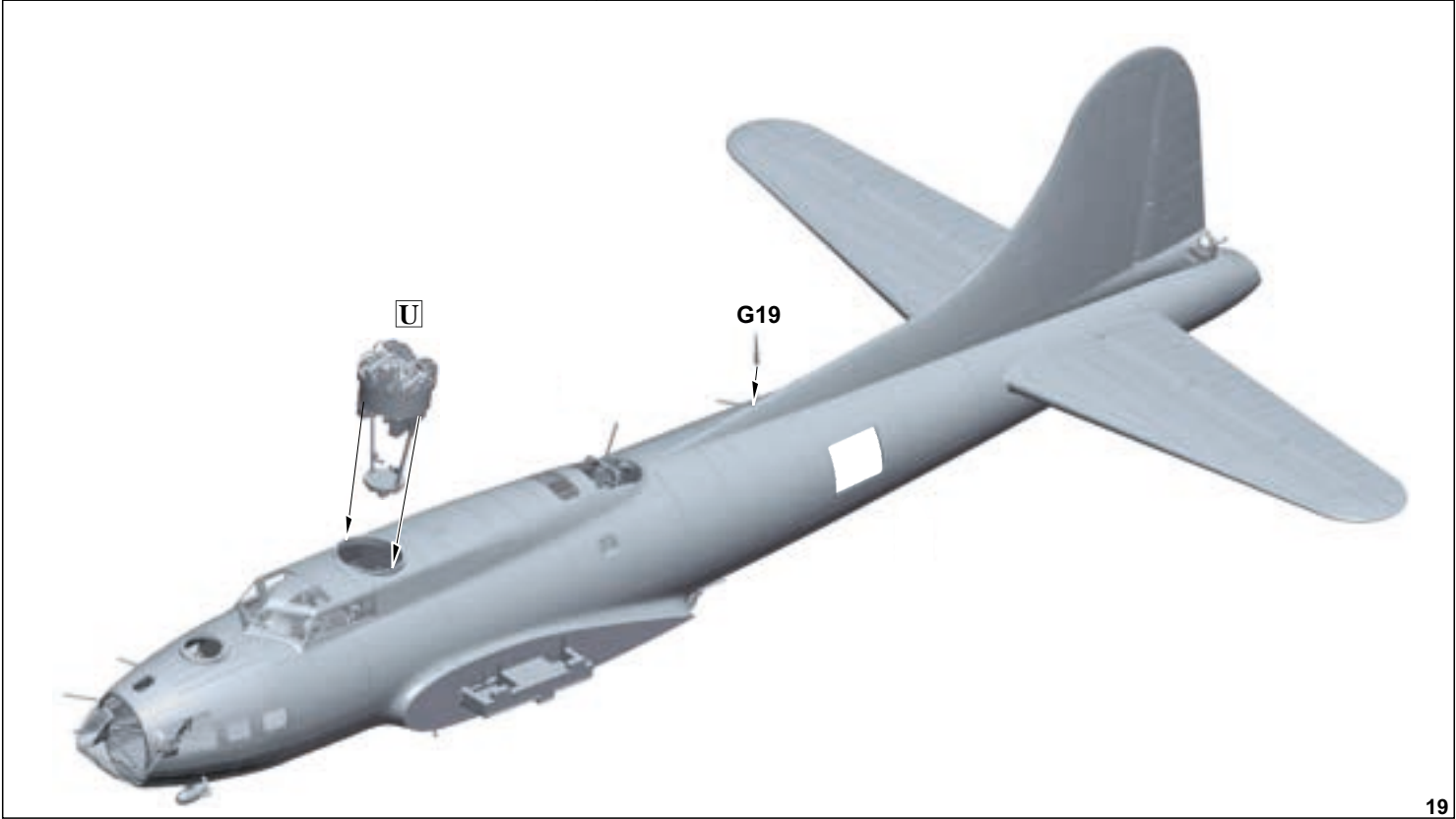
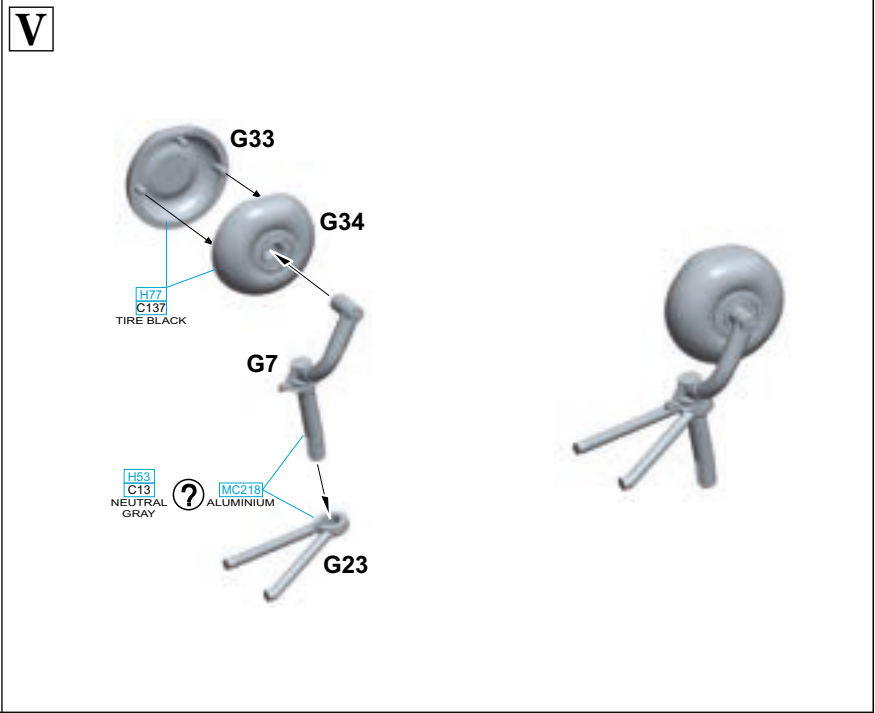
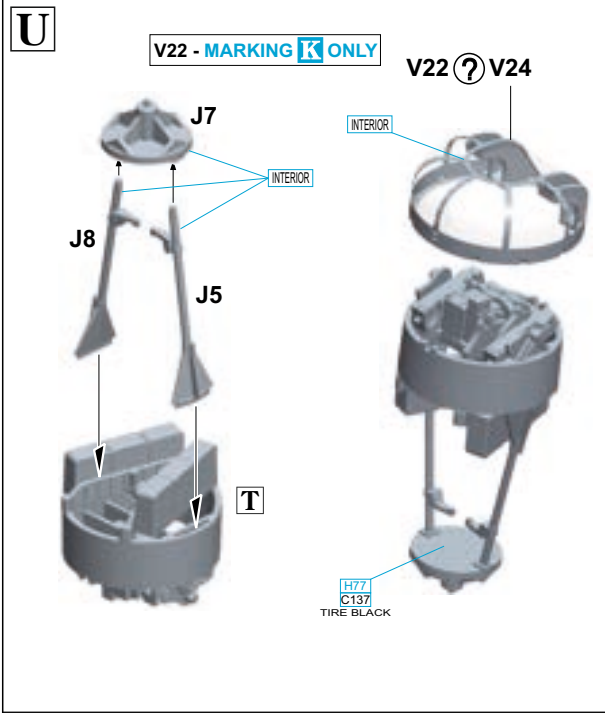
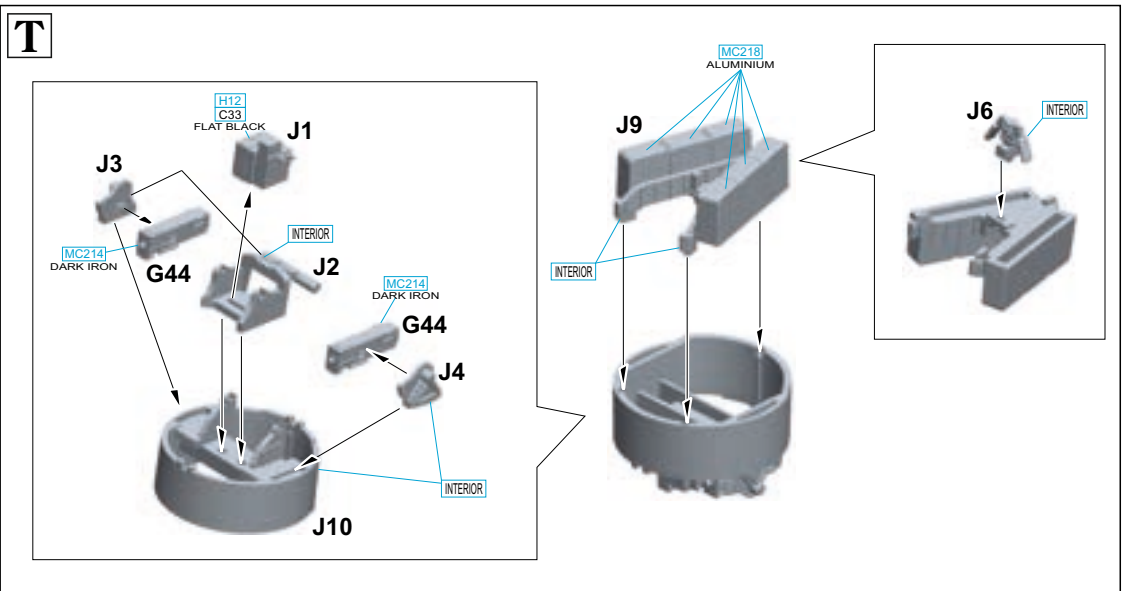
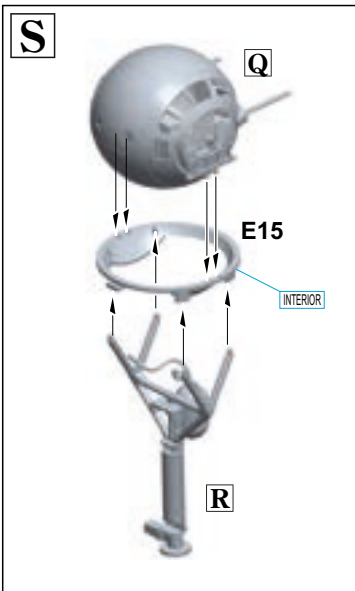

CLOSED

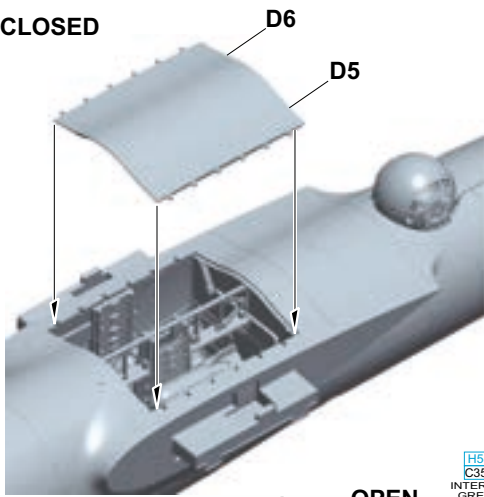

OPEN

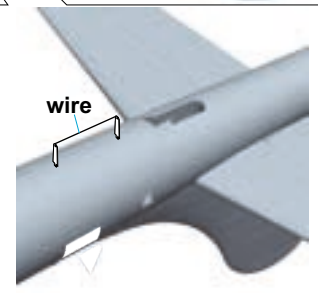
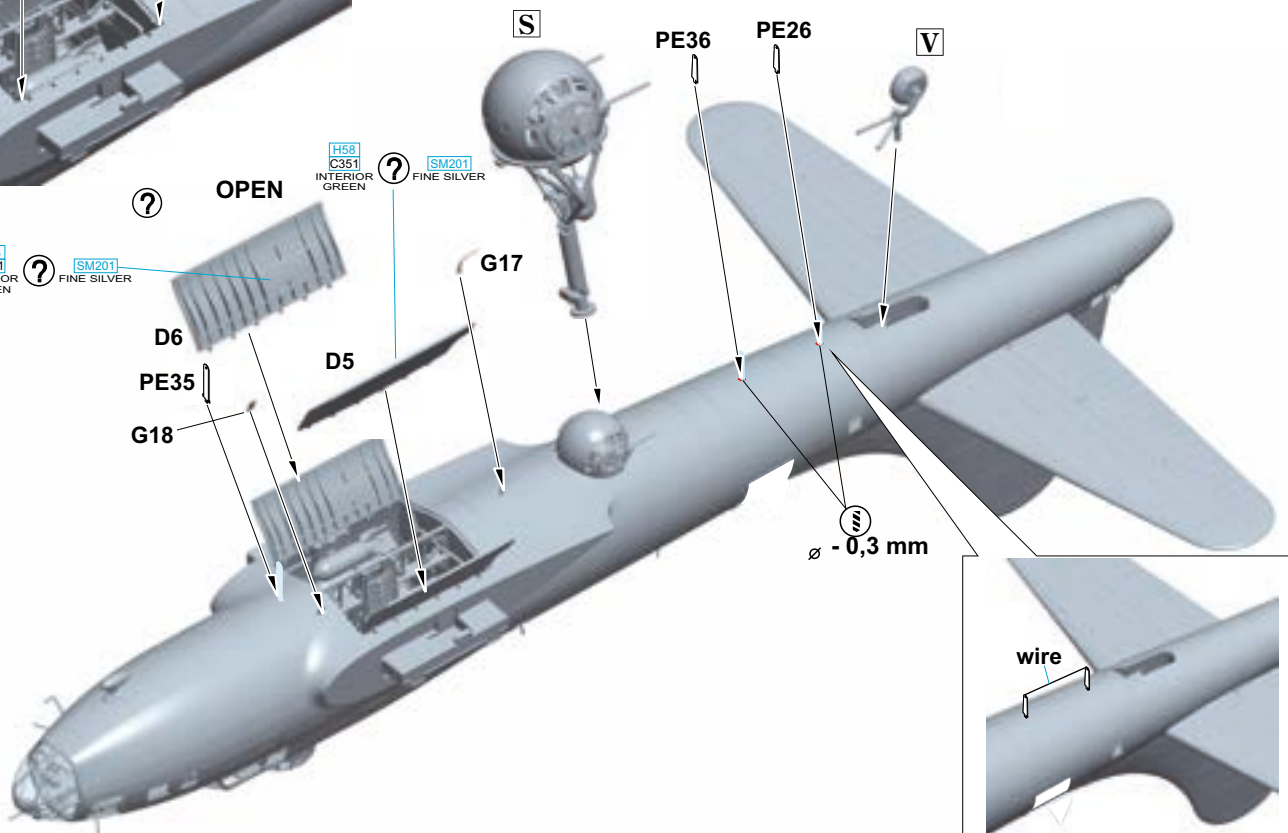
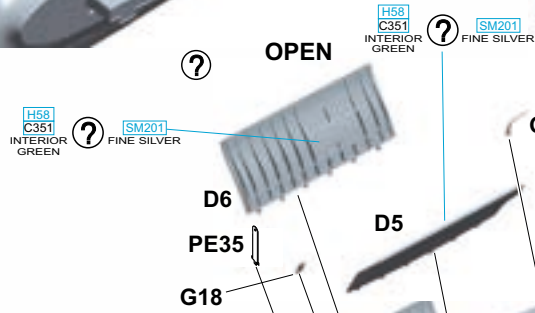

C2

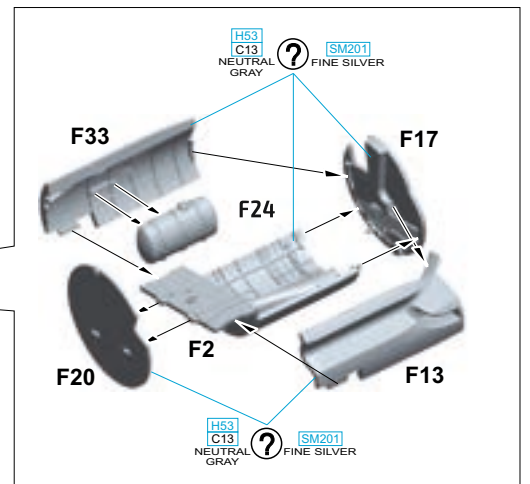
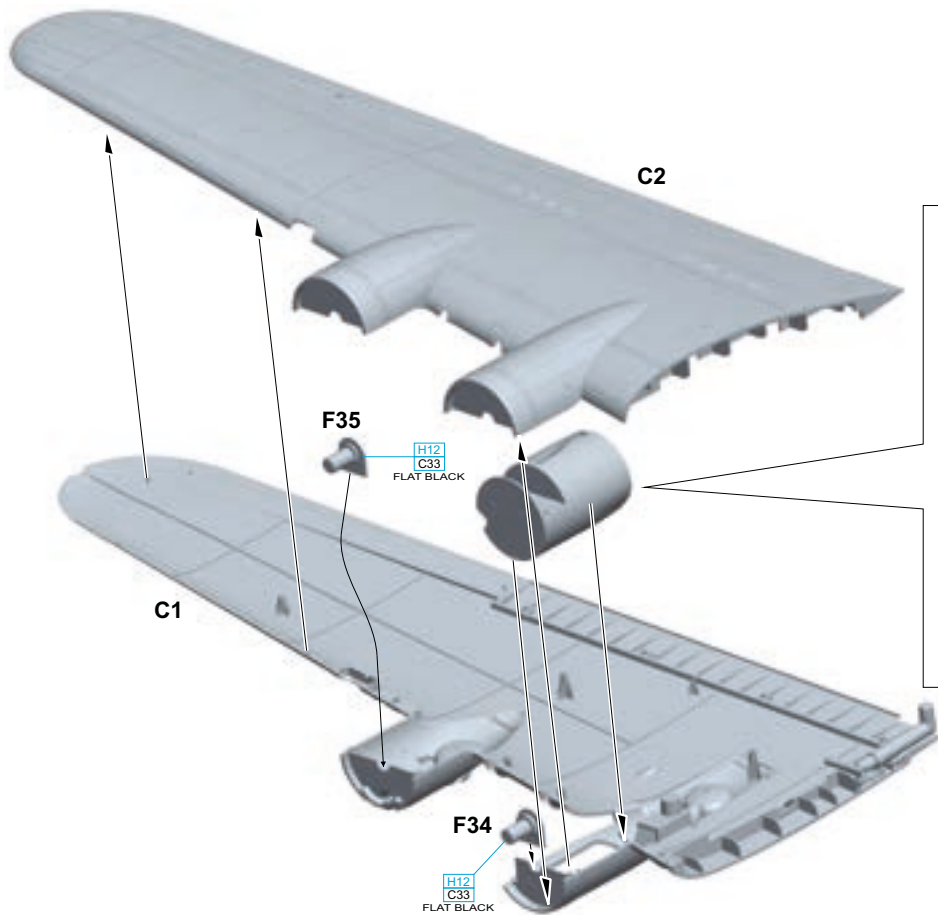

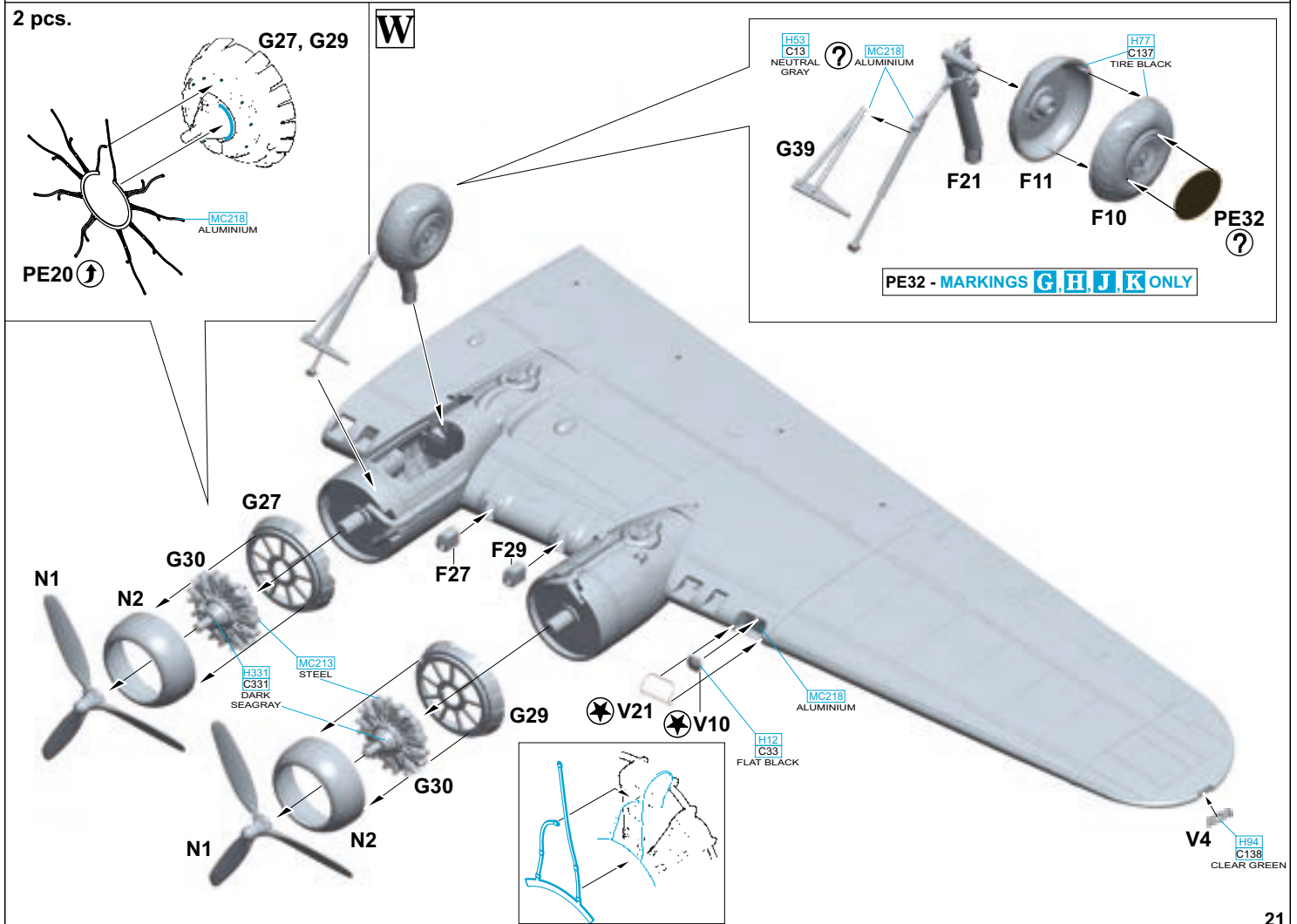
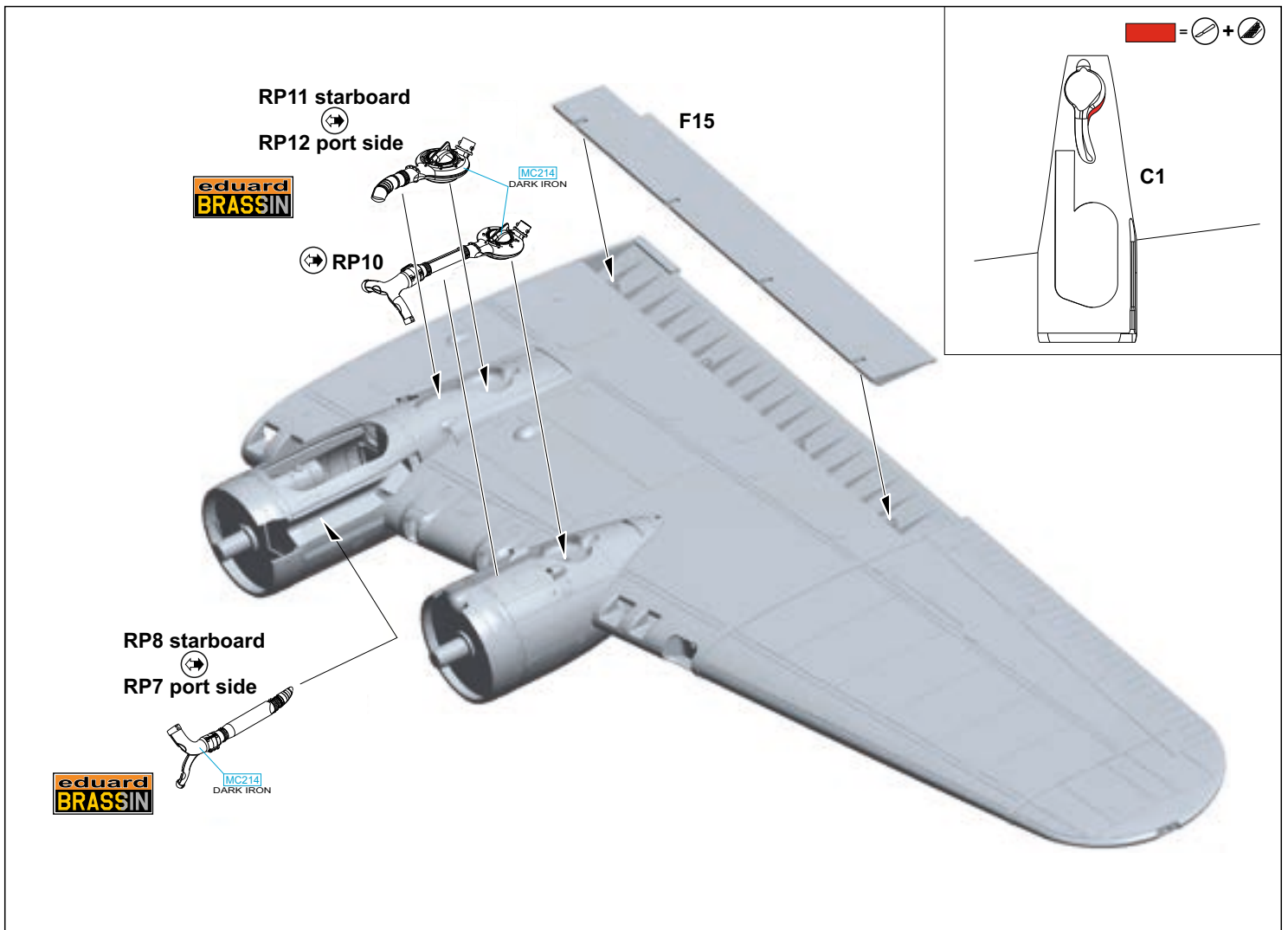

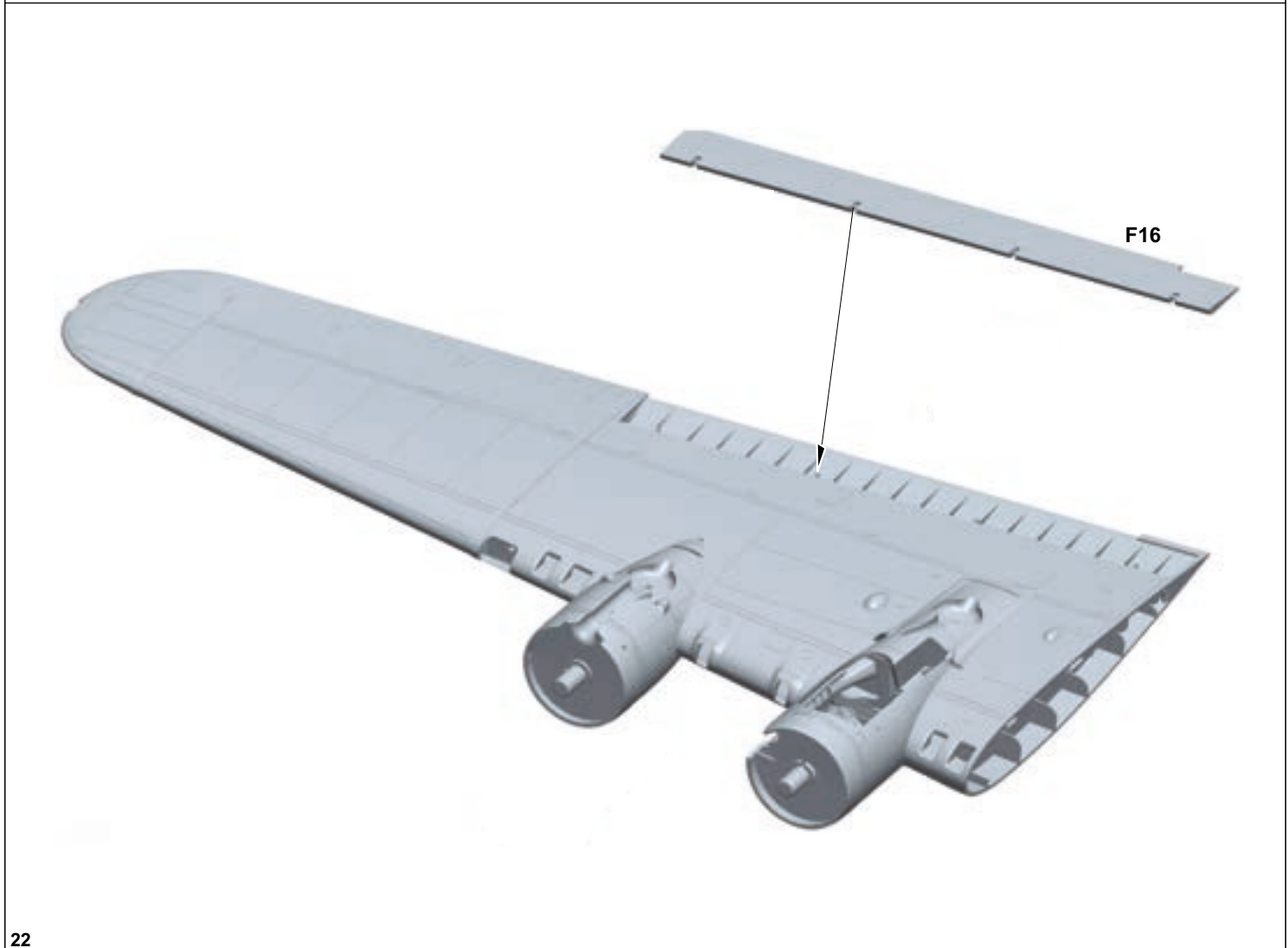
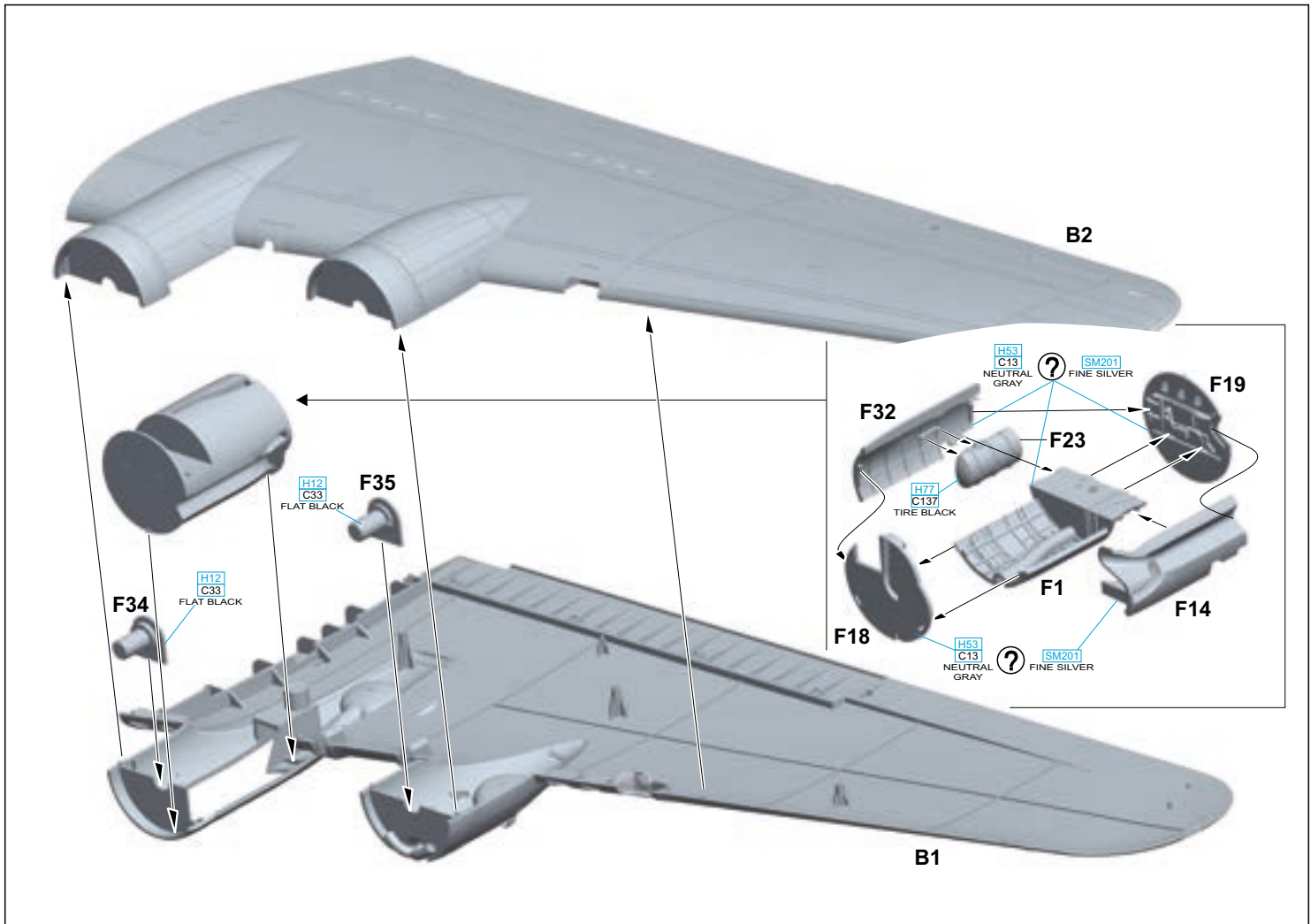

X

PE32 - MARKINGS G, H, J, K ONLY

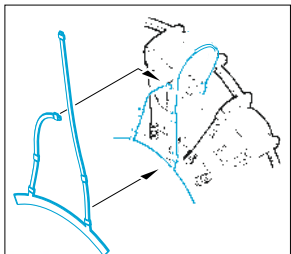

H90
C47
V3
CLEAR RED

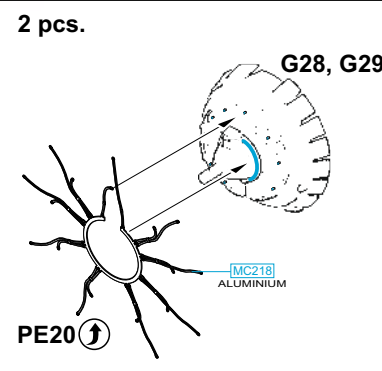
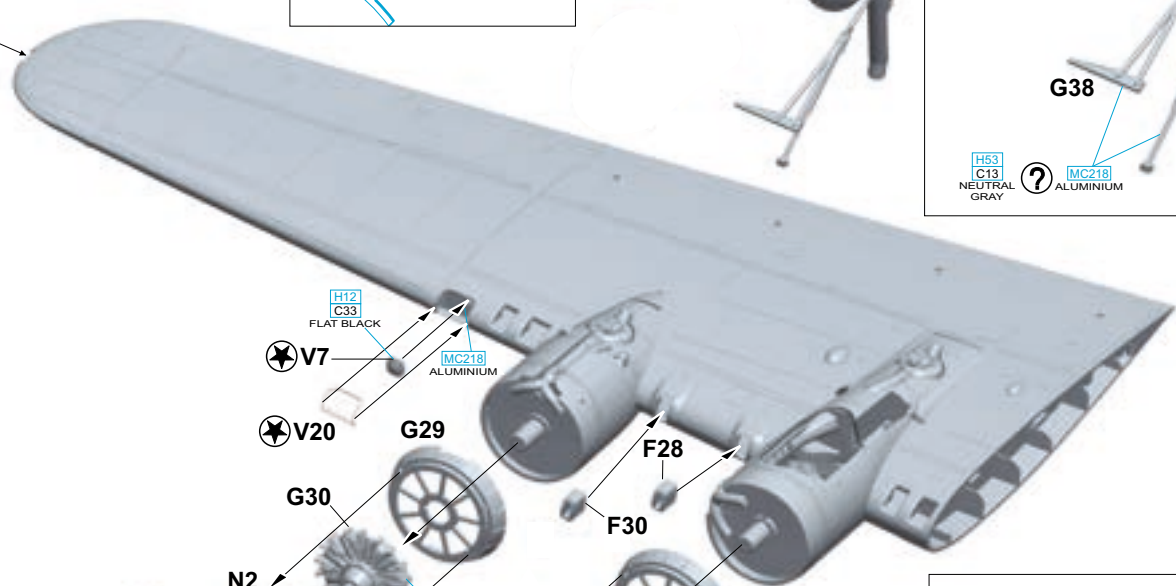
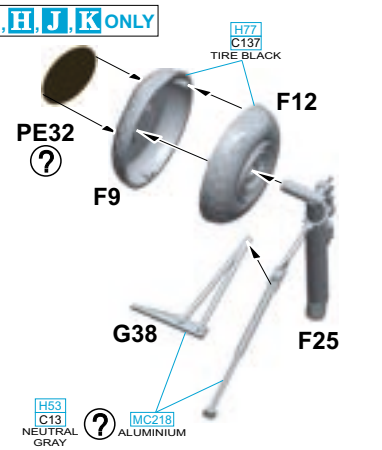

W

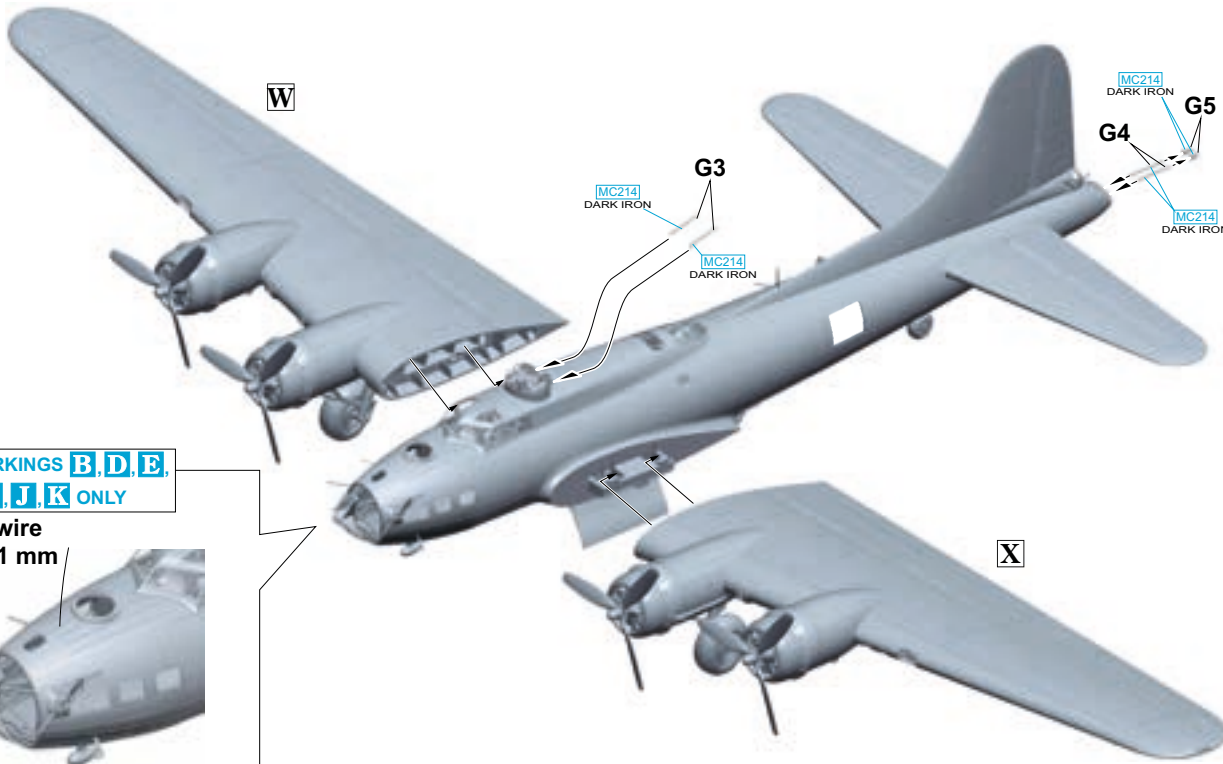

wire - MARKINGS B, D, E, G, H, I, J, K ONLY

wire
1 - 21 mm



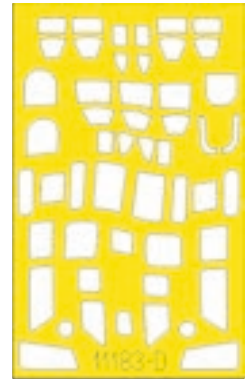
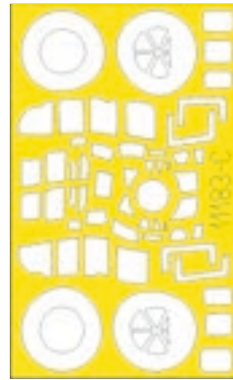
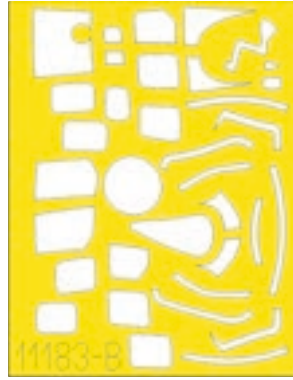

LIQUID MASK

X3

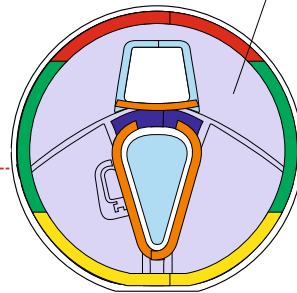

LIQUID MASK

X4

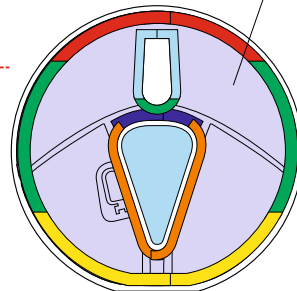

LIQUID MASK

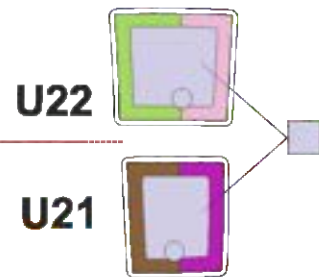
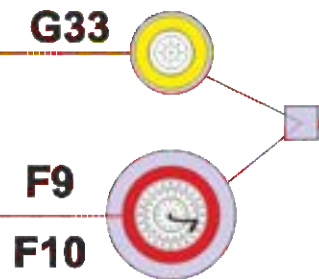
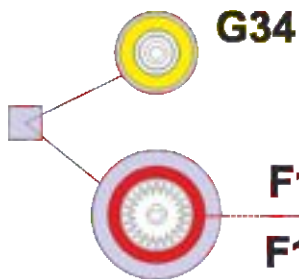
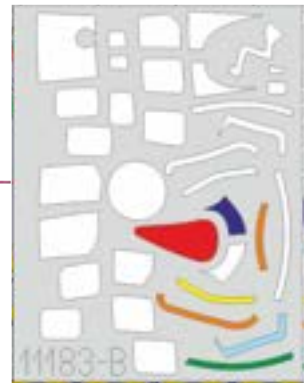
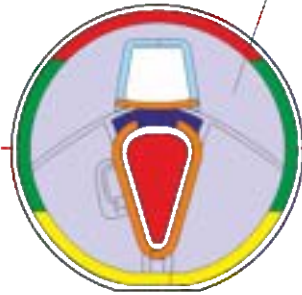

U5 V12



U23

OUTSIDE



X6

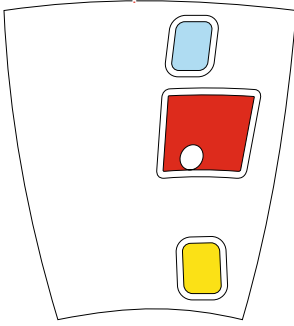

X2

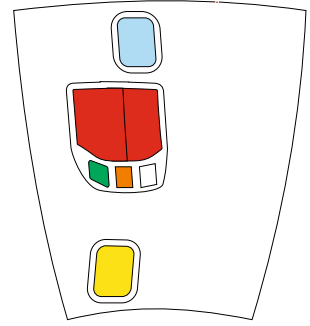

X7

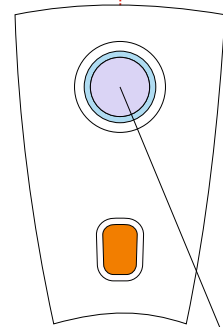

X5

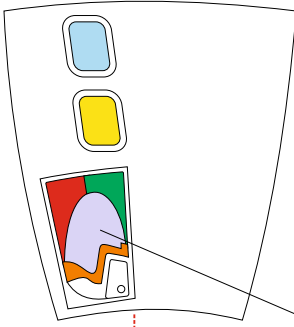

X1

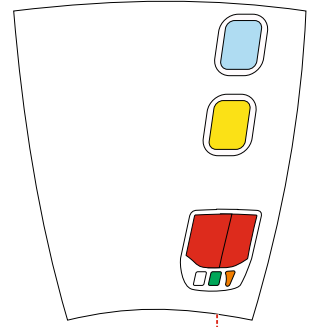

LIQUID MASK

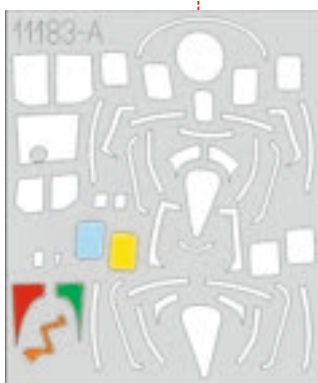

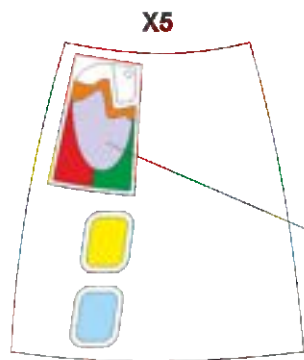
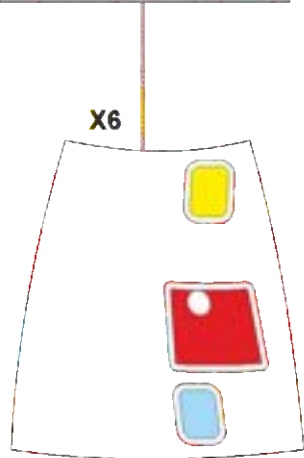
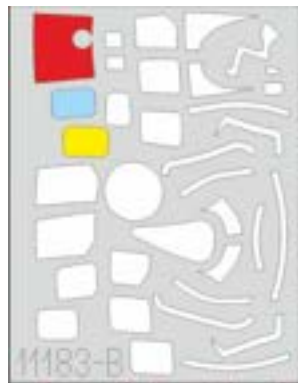

INNER

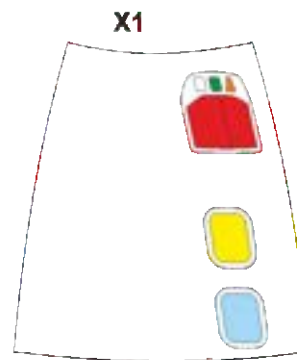
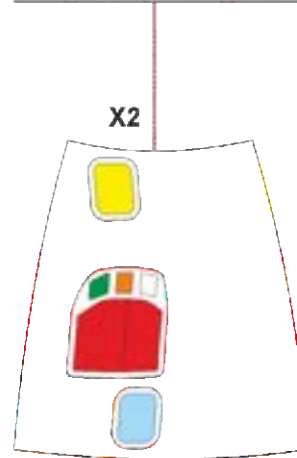
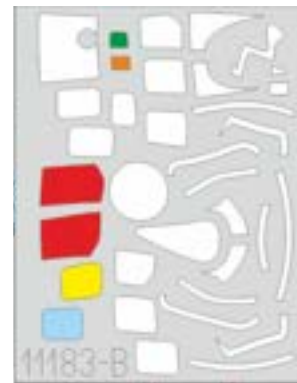
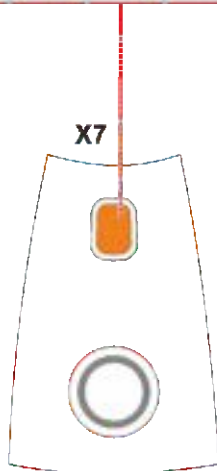

■ LIQUID MASK



V17

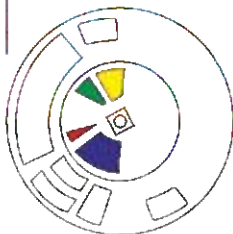

V2



V18

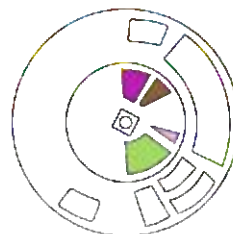

V1

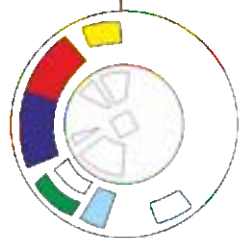

V2

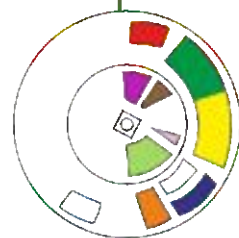

V1

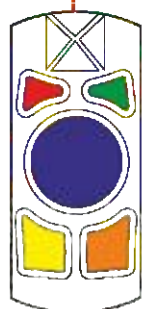

V6



V16 V15

V11

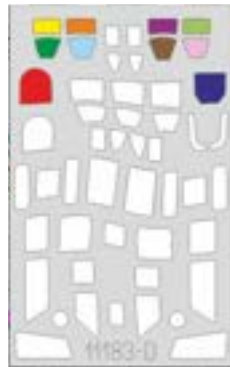

V24



V24



V24



V22



V22

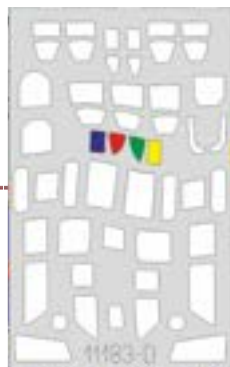

V22



LIQUID MASK

W2

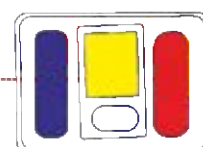
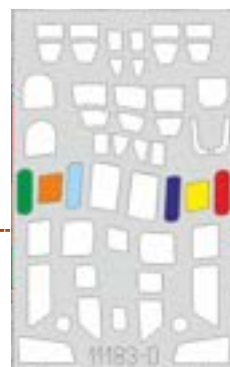
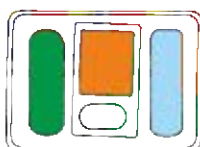

W1

A B-17F-30-VE, 42-5864, Capt. Thomas E. Murphy crew, Lt. Col. Beirne Lay Jr., 351st BS, 100th BG, Telergma, Algeria, August 1943

Piccadilly Lily, an aircraft flown primarily by the crew of Cpt. Thomas E. Murphy, is probably the most famous B-17F of the 100th BG. This B-17F was one of the original aircraft of the unit with which the 100th BG moved from the United States in early June 1943. Later her story became part of two film projects – the 1949 film *Twelve O'Clock High* and, more recently, the television series *Masters of the Air*. The popularity of the first film was due to screenwriter Bernie Lay, who, on August 17, 1943, with the rank of Lt. Col. and as co-pilot aboard of Lily, undertook a mission to Regensburg. This was the famous "Double Strike Mission", after which the 100th BG landed in North Africa. It was the first of the unit's black days, losing 9 of the 21 aircraft involved. The Hundredth also earned its first Meritorious Unit Citation for this mission. As a Vega Factory Block 30 aircraft, Piccadilly Lily had one of the evolutionary variants of the left cheek gun window. During the Regensburg mission, this aircraft had mission marks painted on the left side only and a noseart of a girl with a halo over her head, on the right. The insignias were larger type 2, only a white star in a blue circle. The propeller hubs were painted black.

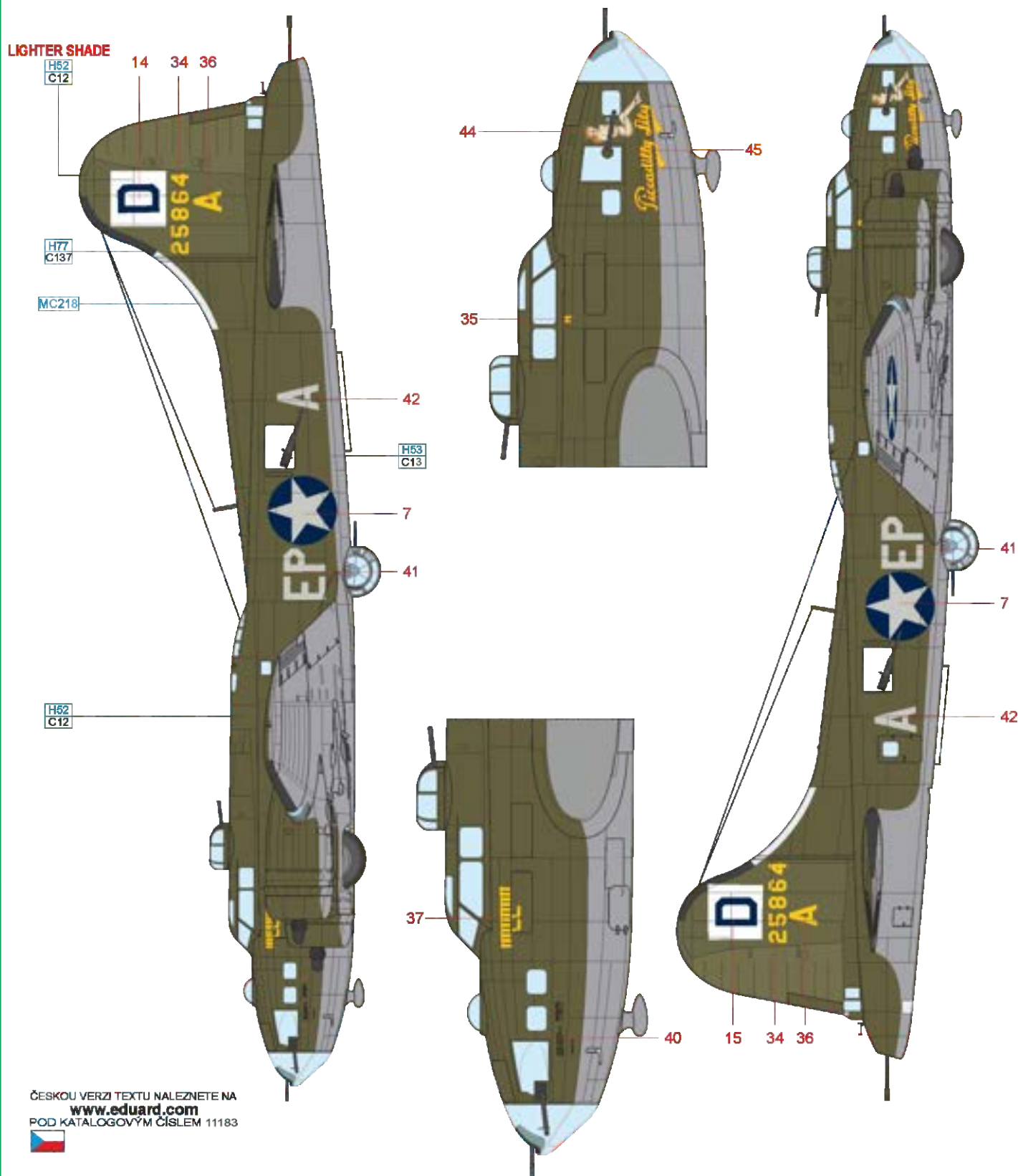

ČESKOU VERZI TEXTU NALEZNETE NA
www.eduard.com
 POD KATALOGOVÝM ČÍSLEM 11183



FLAT BLACK	H12 C33	YELLOW	H329 C329	ALUMINIUM	MC218
OLIVE DRAB	H52 C12	NEUTRAL GRAY	H53 C13	TIRE BLACK	H77 C137
				CHROME SILVER	MC211

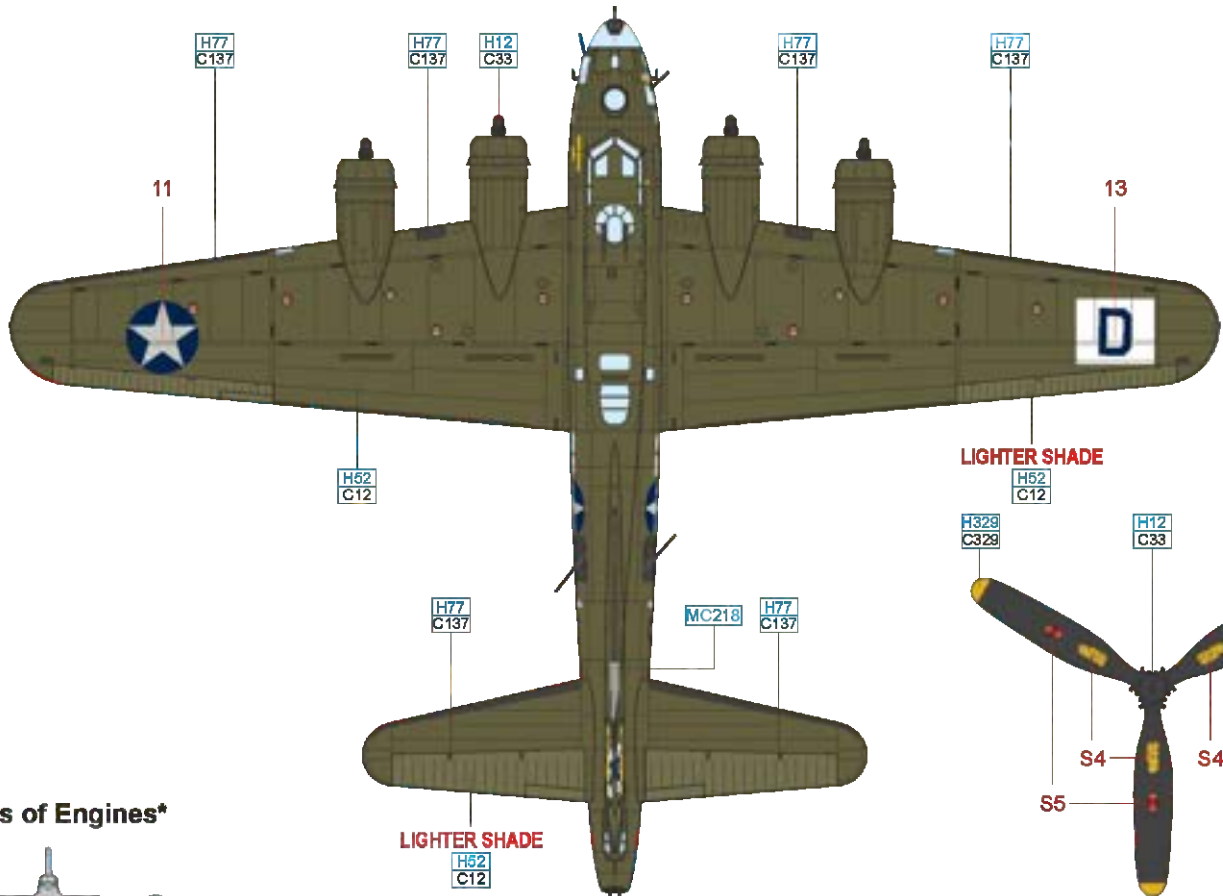

Types of Engines*



* Letter W for Wright Engine
Letter S for Studebaker Engine

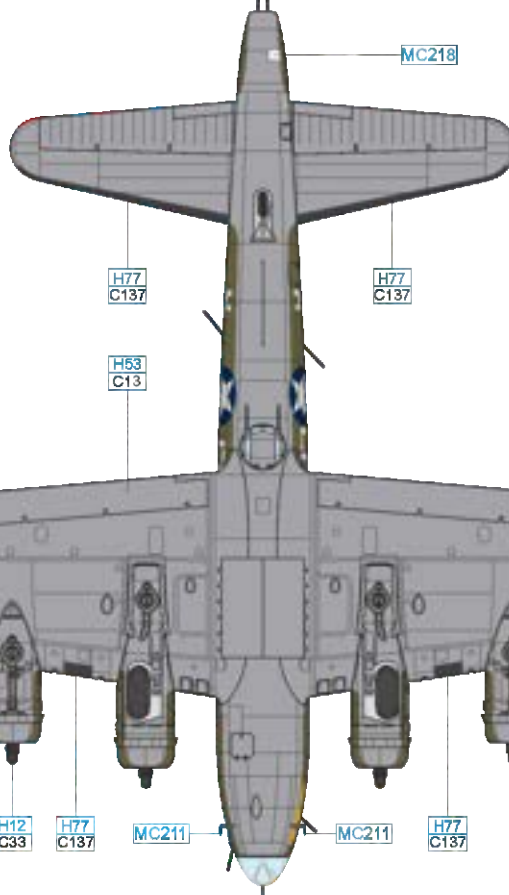

ČESKOU VERZI TEXTU NALEZNETE NA
www.eduard.com
POD KATALOGOVÝM ČÍSLEM 11183



B B-17F-30-VE, 42-5864, Capt. Thomas E. Murphy crew, 351st BS, 100th BG, Thorpe Abbots, United Kingdom, September 1943

The appearance of Piccadilly Lily less than two months later, in early October 1943, differed mainly in the form of the national insignia. According to the regulation from the end of June 1943, the simple blue circles with a star were changed to type 3, i.e. white stripes were added to the blue circle and the whole emblem was given a red border. This design was due to be changed again in mid-August 1943, however, on that time it had not even been applied to most American aircraft in Europe. The red trim on the 100th BG aircraft remained at the end of September 1943, when the regulation then required the outline to be blue. Compared to the original form of Piccadilly Lily, the position of the code letters EP was also changed due to the change of the insignia. The mission marks and victories claimed by the gunners were also added on the starboard side of the nose. Another minor change was the partial removal of the de-icing boots on the leading edge of the vertical stabilizer. Lily was lost on October 8, 1943, during the raid on Bremen. From Capt. Murphy's crew, six men were killed, among them, the squadron operations officer, Capt. Alvin L. Barker, who joined the crew at the last moment before takeoff.

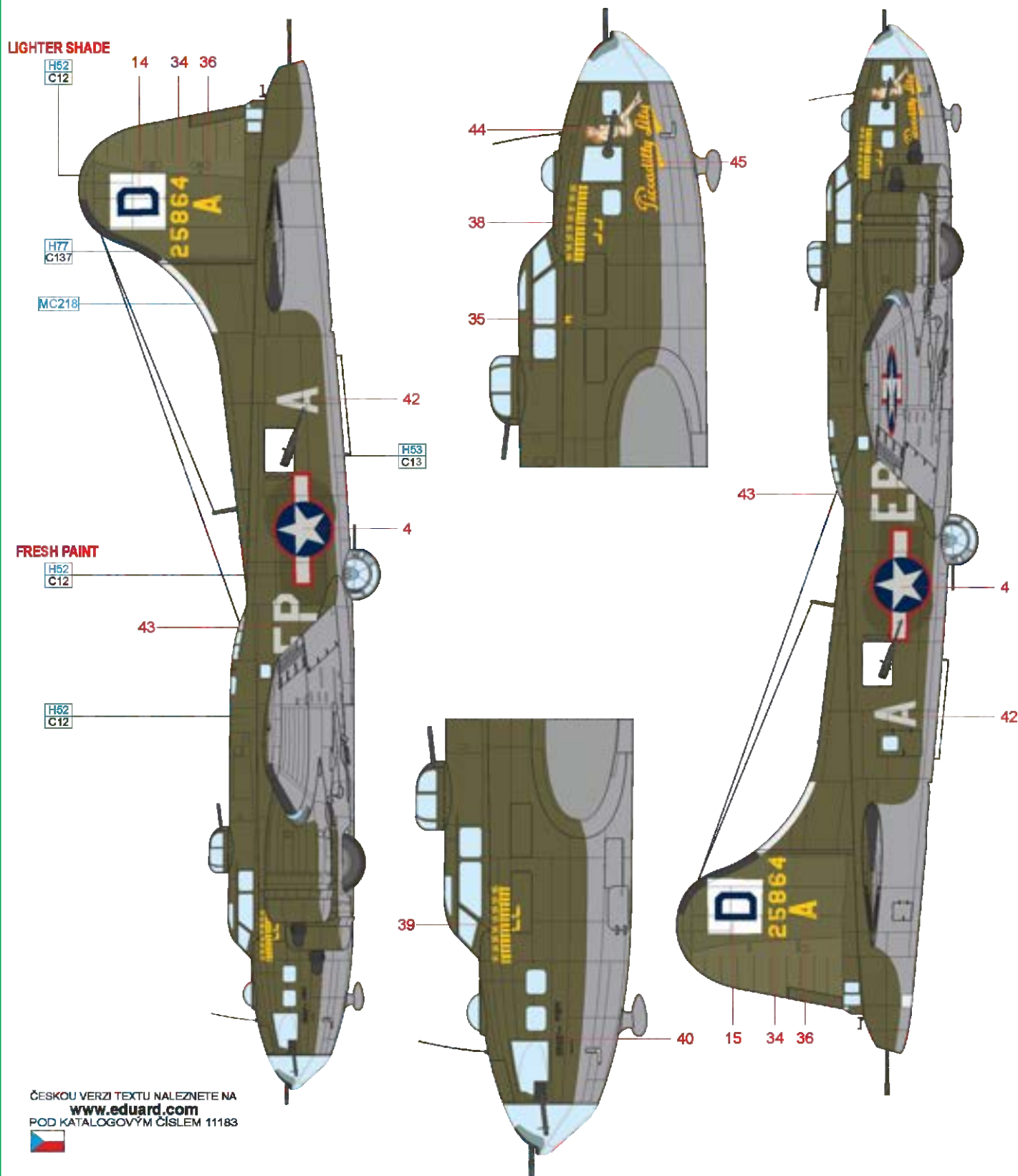

ČESKOU VERZI TEXTU NALEZNETE NA
www.eduard.com
 POD KATALOGOVÝM ČÍSLEM 11183



FLAT BLACK	H12 C33	YELLOW	H329 C329	ALUMINIUM	MC218
DRAB	H62 C12	NEUTRAL GRAY	H53 C13	TIRE BLACK	H77 C137
				CHROME SILVER	MC211

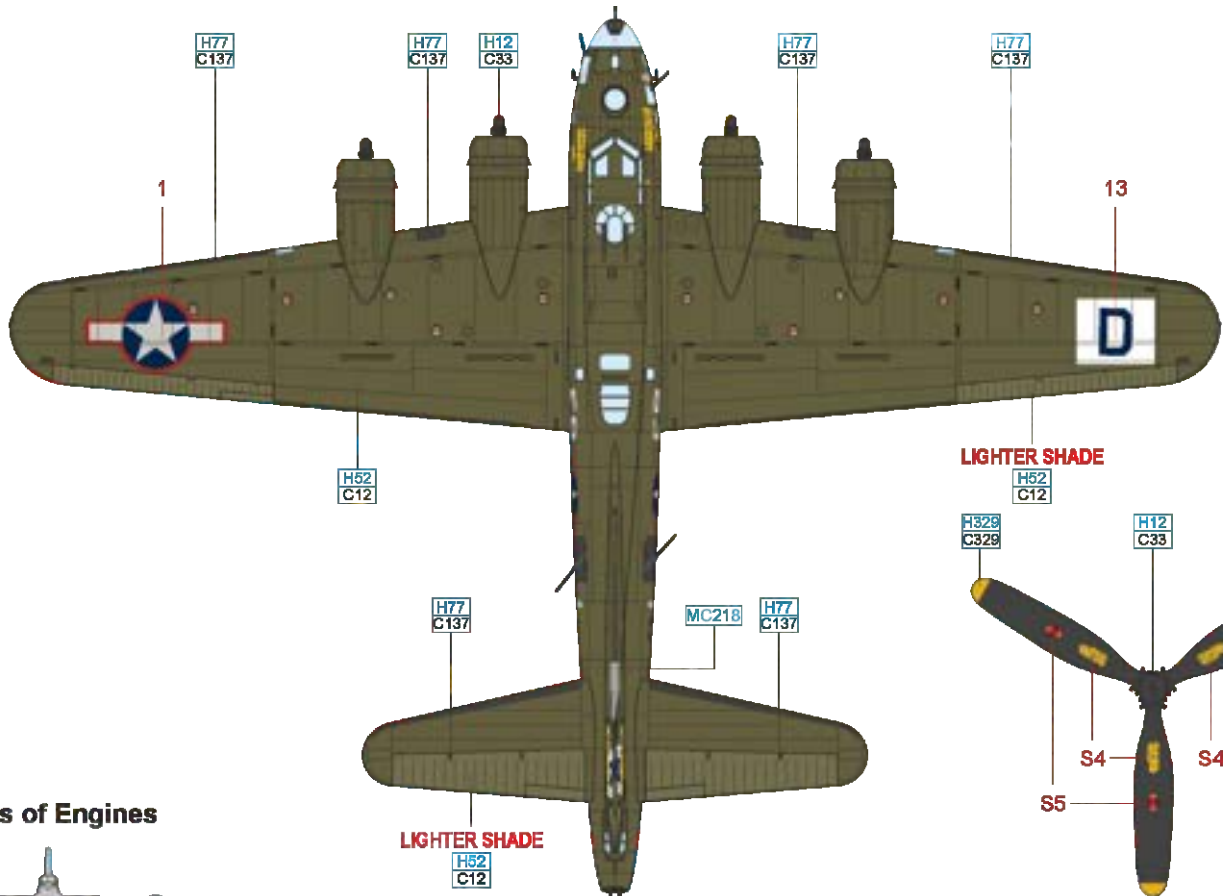

Types of Engines



* Letter W for Wright Engine
Letter S for Studebaker Engine

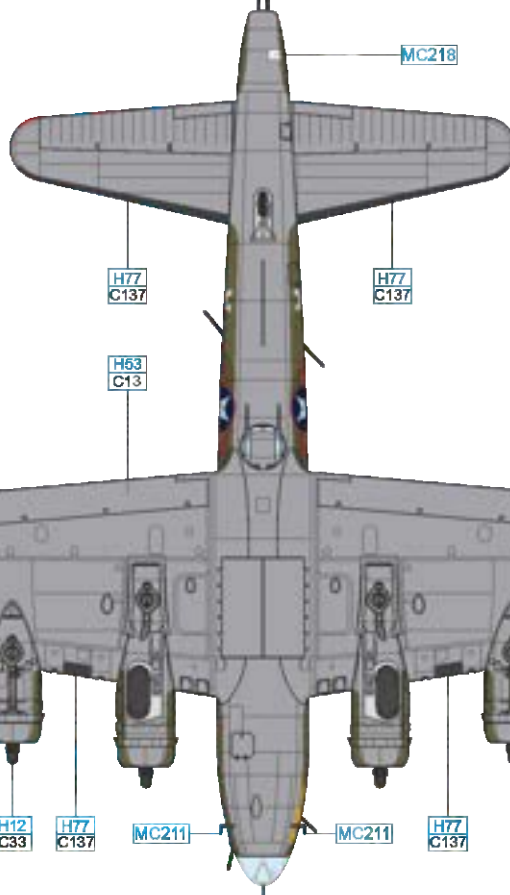

ČESKOU VERZI TEXTU NALEZNETE NA
www.eduard.com
POD KATALOGOVÝM ČÍSLEM 11183



C B-17F-30-VE, 42-5867, Lt. William D. DeSanders crew, 350th BS, 100th BG, Thorpe Abbots, United Kingdom, August 1943

Alice from Dallas was one of the original B-17Fs that moved to England with the unit after completing training in the US. She was assigned to the crew of Lt. William D. DeSanders of the 350th BS. He named the aircraft after his wife. The aircraft was built in the 30th F-series production block at the Vega factory. Among other specifics typical of this production, such as larger emblems on the fuselage and low camo paint interfaces, it had one of the evolutionary forms of cheek gunnery installed on the port side of the nose. The white lettering on the nose on both sides was complemented by small drawings of a gremlin releasing bombs from a potty. It was a simplified figure from the 350th BS emblem. The white stars in the enlarged Type 2 emblem on the fuselage of this aircraft had a darker blue border. The propeller hubs were black. For the raid on Regensburg on August 17, 1943, as part of the Regensburg-Schweinfurt Double Strike mission, due to the illness of the original pilot, Alice was assigned Lt. Roy F. Claytor and his crew. During this mission, in which the Blood Hundred lost 9 aircraft, Alice was also shot down. Two of the ten-man crew were killed. Five of the eight surviving airmen unusually managed to escape capture.

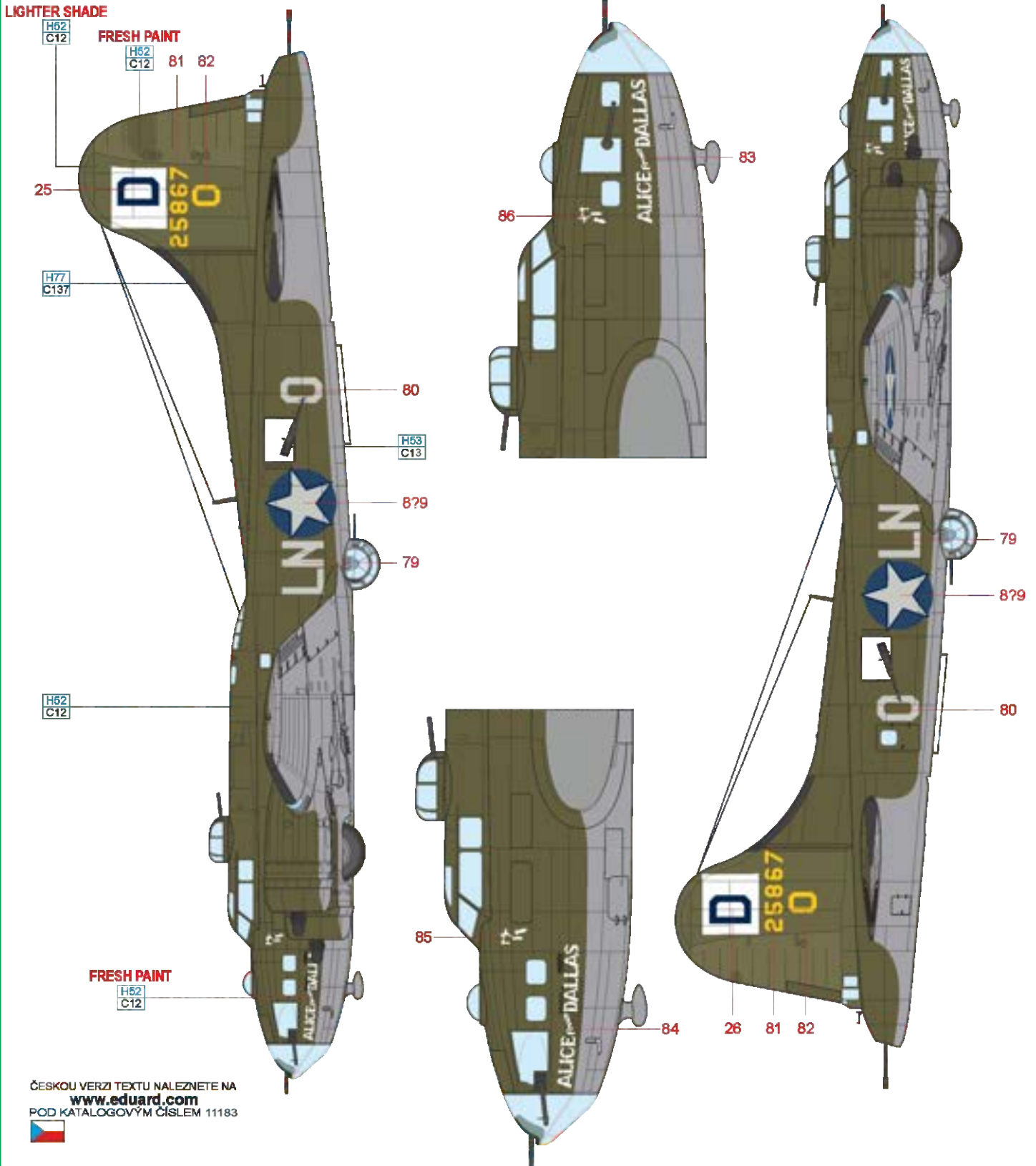

ČESKOU VERZI TEXTU NALEZNETE NA
www.eduard.com
 POD KATALOGOVÝM ČÍSLEM 11183



FLAT BLACK	H12	YELLOW	H329
	C33		C329
DRUM TANN	H62	NEUTRAL GRAY	H53
	C12		C13
		TIRE BLACK	H77
			C137
		CHROME SILVER	MC211

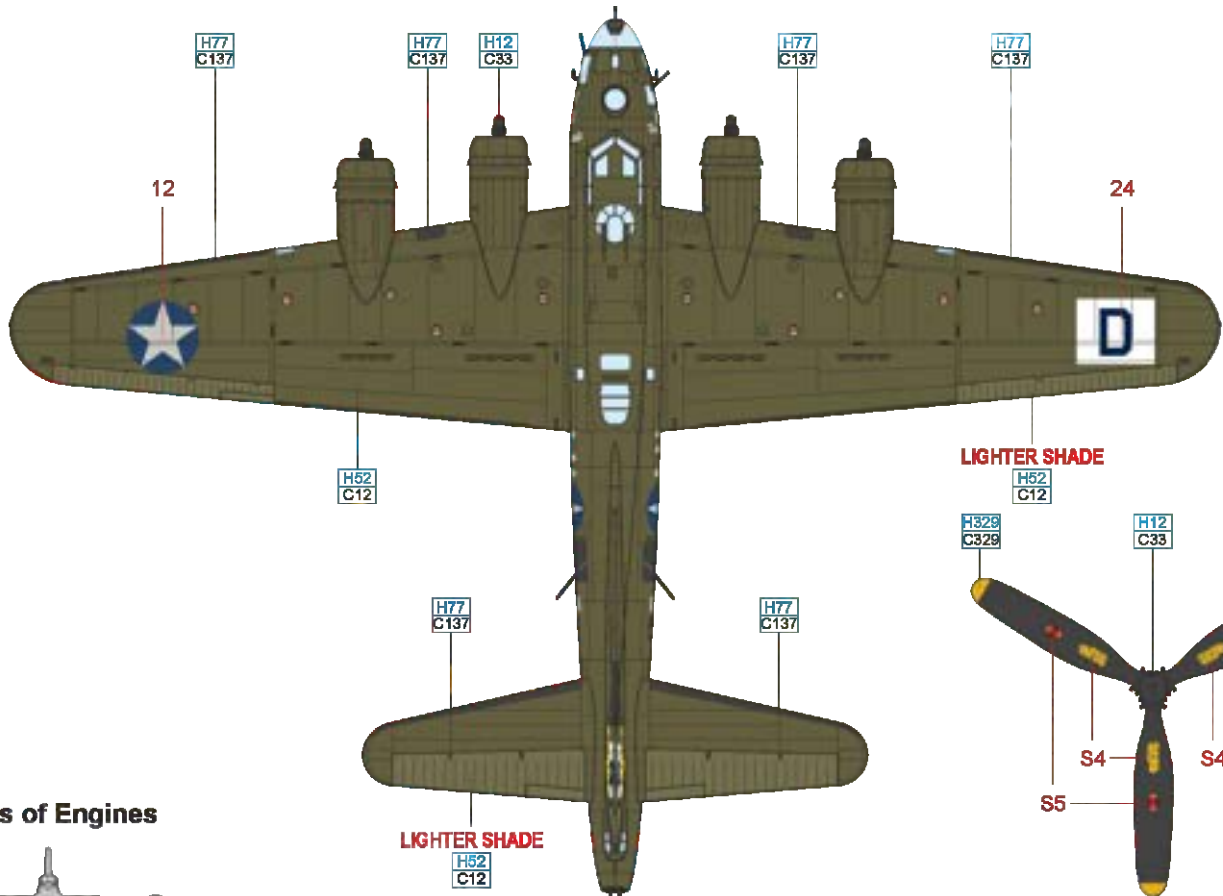

Types of Engines



* Letter W for Wright Engine
Letter S for Studebaker Engine

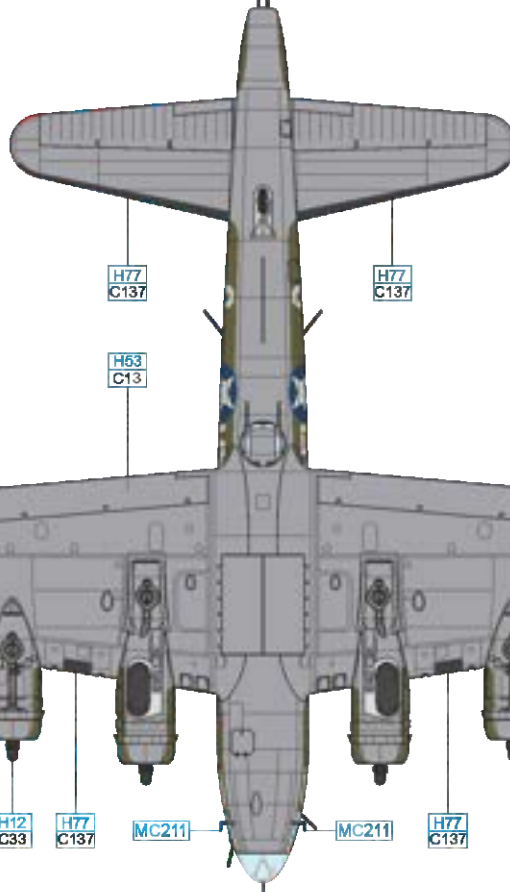

ČESKOU VERZI TEXTU NALEZNETE NA
www.eduard.com
POD KATALOGOVÝM ČÍSLEM 11183



D B-17F-120-BO, 42-30796, Capt. Glenn W. Dye crew, 351st BS, 100th BG, Thorpe Abbots, United Kingdom, September 1943

The crew of Lt. Glenn W. Dye was one of the original 100th BG crews that moved to England after stateside training as a whole group. This crew was the unit's first, and the only one from the original 35 crews, to complete a tour of 25 missions. Their primary aircraft, named Sunny, was lost with another crew on September 3, 1943. They therefore named their new B-17F, Sunny II, and completed the tour with her on September 16, 1943. The limit of 25 missions at the time, was not reached by co-pilot, Lt. Luckadoo, who, due to his assignment to new crews training duty, was 4 missions short. In mid-September 1943, Sunny II bore the markings of two missions on the nose. The national insignia was Type 3 - with stripes and a red border. De-icing boots were removed from the leading edge of the wing but were retained on the tailplane stabilizers. The aircraft at this time did not yet have armored cockpit glass installed. The co-pilot of the Sunny II, Lt. John H. Luckadoo, finished his tour duty as operations officer of the sister 350th BS in February 1944. Today, "Lucky" Luckadoo is one of the last surviving veterans of the 100th BG, and at 102 years, he is still active in keeping the legacy of his unit and his World War II comrades.

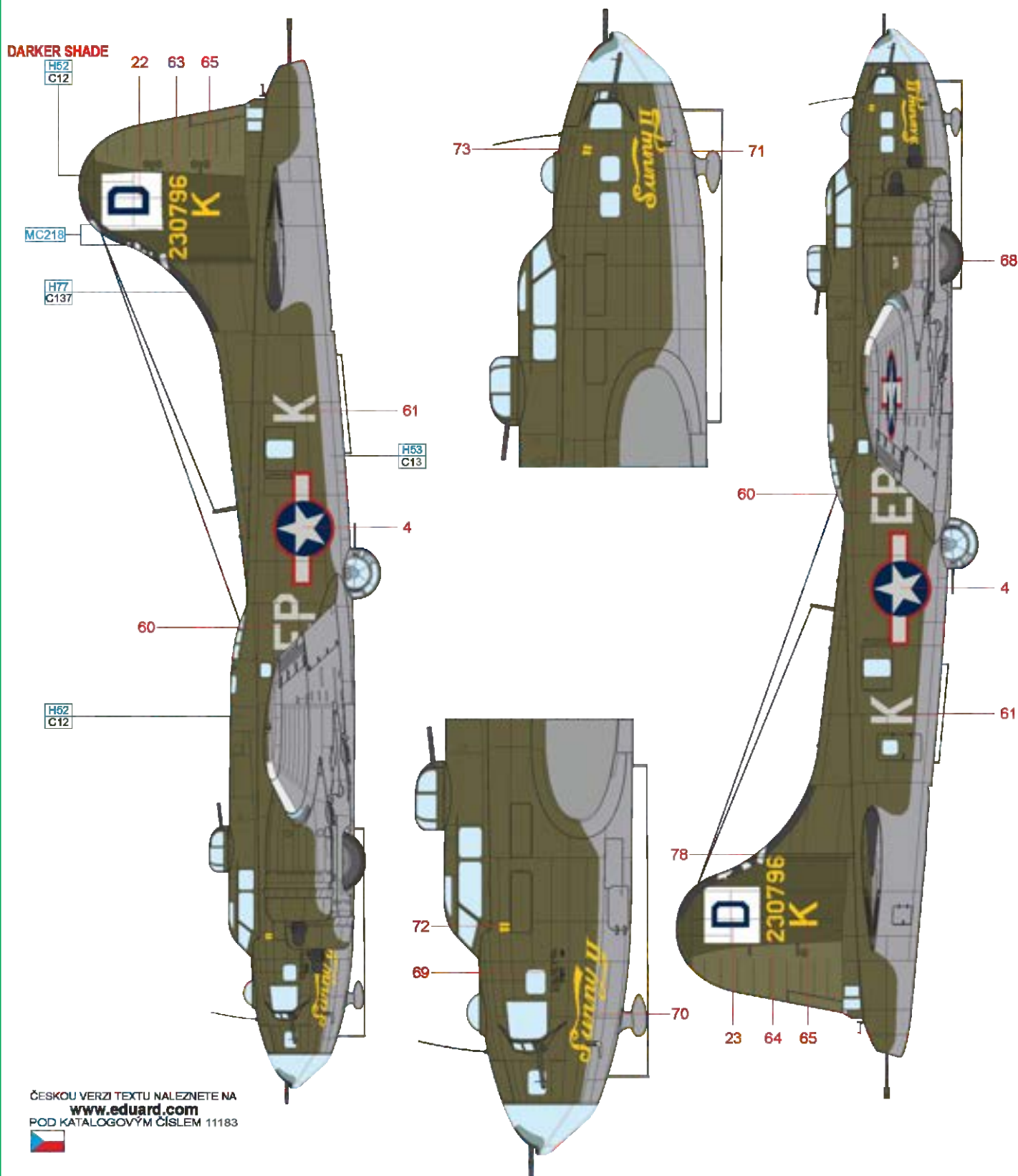

ČESKOU VERZI TEXTU NALEZNETE NA
www.eduard.com
 POD KATALOGOVÝM ČÍSLEM 11183



FLAT BLACK	H12 C33	YELLOW	H329 C329	ALUMINIUM	MC218
OLIVE DRAB	H62 C12	NEUTRAL GRAY	H53 C13	TIRE BLACK	H77 C137
				CHROME SILVER	MC211

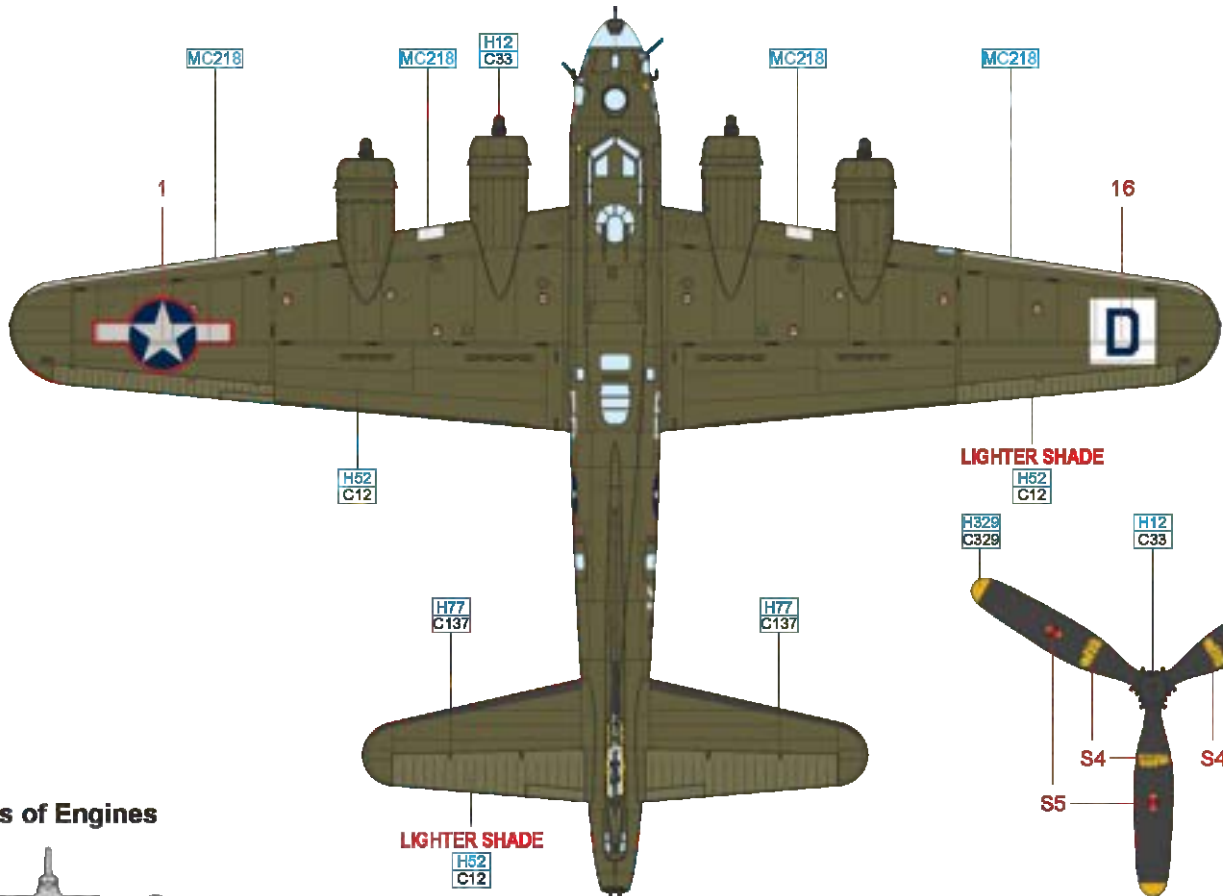

Types of Engines



* Letter W for Wright Engine
Letter S for Studebaker Engine

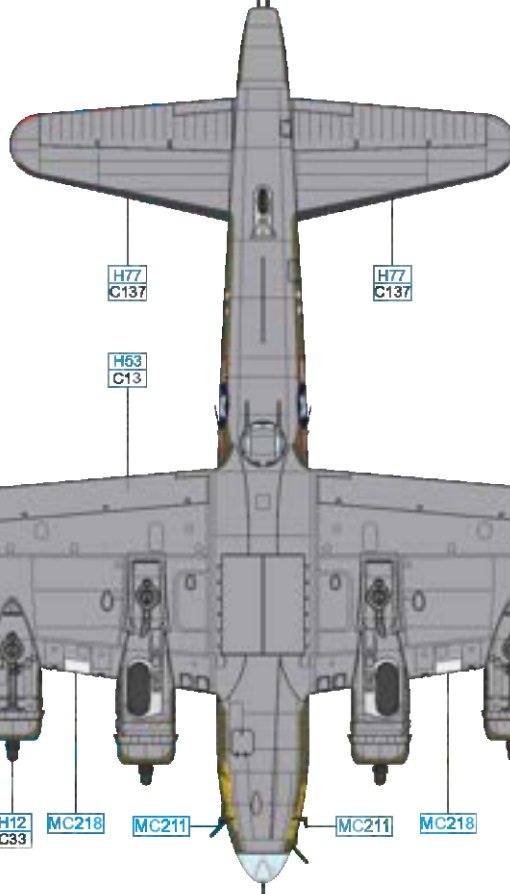

ČESKOU VERZI TEXTU NALEZNETE NA
www.eduard.com
POD KATALOGOVÝM ČÍSLEM 11183



After Glenn W. Dye's crew had its combat tour completed, other crews flew with Sunny II, increasing her score to 14 missions, during which she sustained major combat damage and more than once returned with wounded aboard. The main changes to the aircraft's appearance since the previous described condition, apart from the many painted bombs and swastikas marking, include the repainting of the red trim of the national insignia with blue paint and a change of the aircraft's individual letter. When Sunny II underwent one of her more challenging repairs, the letter K was assigned to another, newly arrived B-17G. She was therefore given a replacement letter J. A white stripe was added to the top of the rudder for quick identification in formation. The Sunny II's mission over Ludwigshafen on December 30, 1943, proved extremely dangerous, when flak fire over the target knocked out two engines. The lone return ended in a good luck for the crew of Lt. George W. Brannan with an emergency landing near Thorpe Abbots. Sunny II was destroyed but was able to bring her crew home again. The men of Lt. Brannan's crew continued their missions until March 6, 1944, when they were shot down in a mission to Berlin.

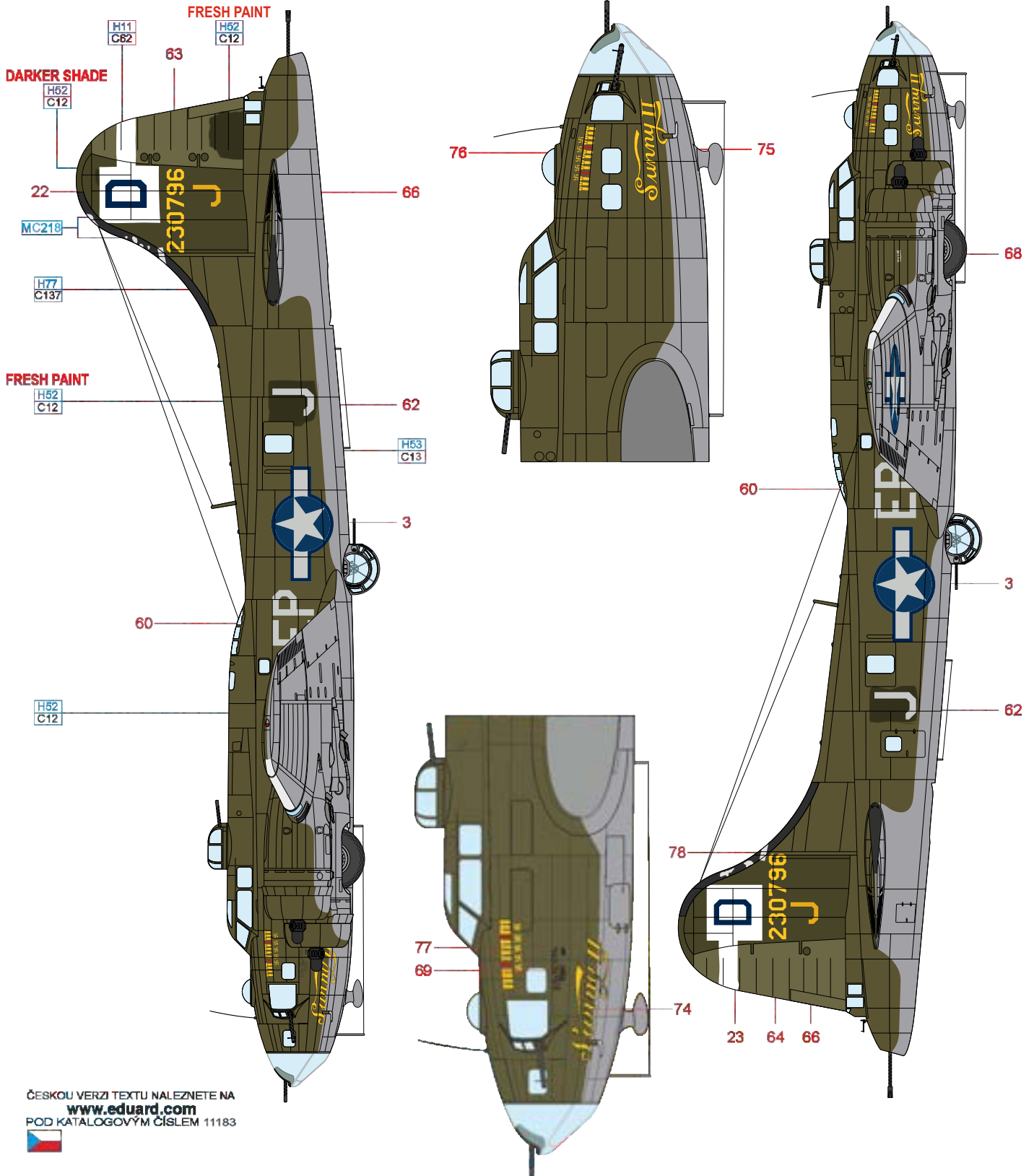

ČESKOU VERZI TEXTU NALEZNETE NA
www.eduard.com
POD KATALOGOVÝM ČÍSLEM 11183



FLAT WHITE	H11 C62	FLAT BLACK	H12 C33	YELLOW	H328 C328	ALUMINIUM	MC218
OLIVE DRAB	H62 C12	NEUTRAL GRAY	H53 C13	TIRE BLACK	H77 C137	CHROME SILVER	MC211

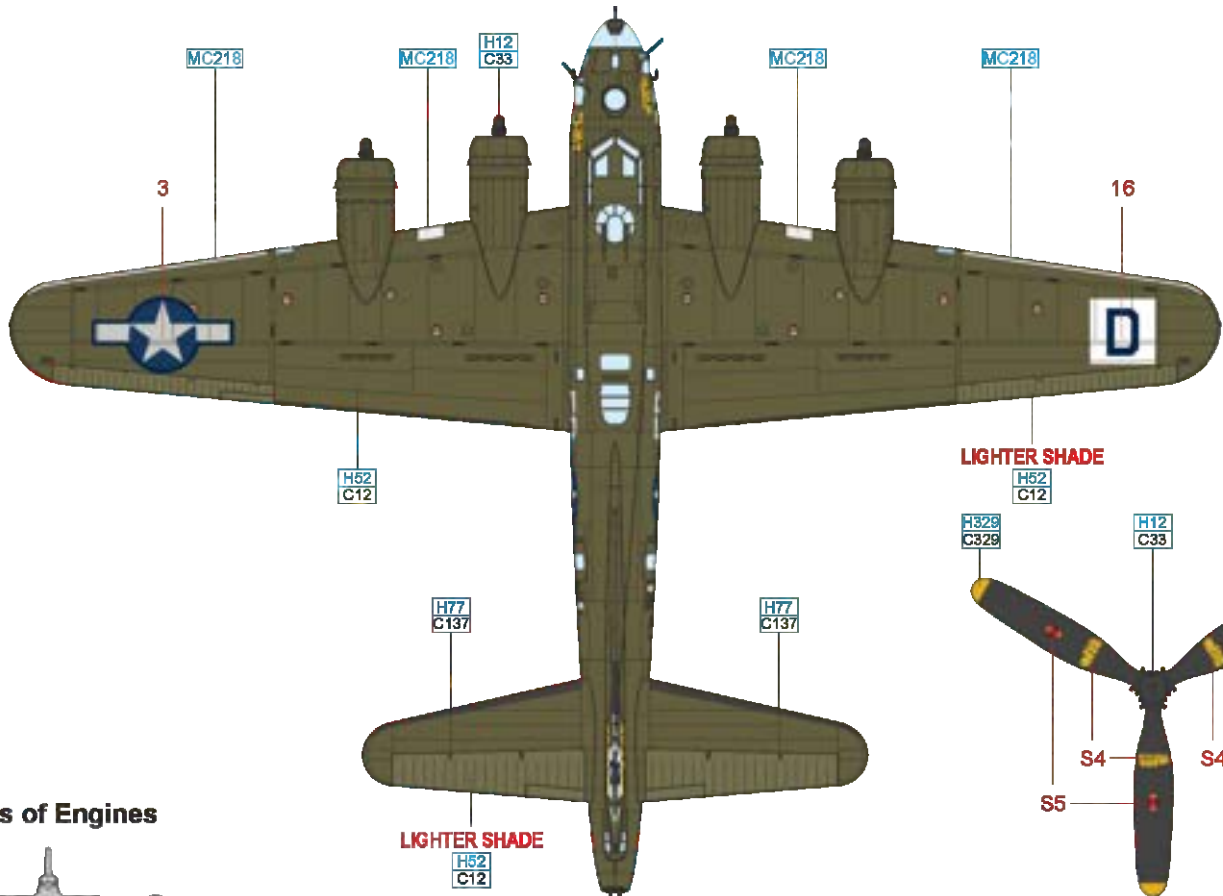

Types of Engines

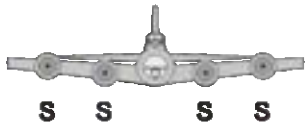

* Letter W for Wright Engine
Letter S for Studebaker Engine

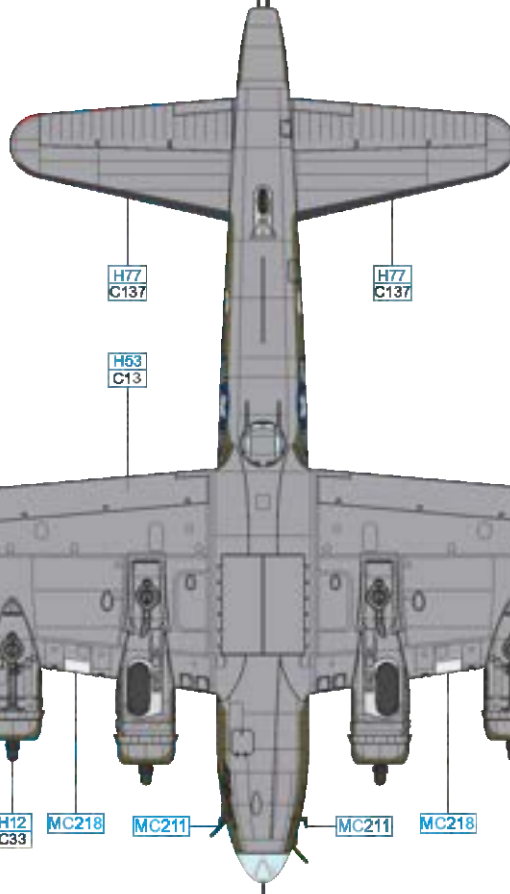

ČESKOU VERZI TEXTU NALEZNETE NA
www.eduard.com
POD KATALOGOVÝM ČÍSLEM 11183



F B-17F-120-BO, 42-30758, Lt. Robert Rosenthal crew, 418th BS, 100th BG, Thorpe Abbots, United Kingdom, October 1943

The crew of Lt. Robert "Rosie" Rosenthal began their tour of duty with three combat missions in three days. They took off for the first on October 8, 1943, in a new B-17F, named Rosie's Riveters. The baptism of fire for Rosenthal's crew was the mission to Bremen, in which seven aircraft from their unit were shot down. They themselves returned in a severely damaged Rosie's Riveters. The next day they flew a borrowed B-17F, Royal Flush. And the day after, on October 10, 1943, Rosenthal's crew took off again in Royal Flush for Münster. The Bloody Hundredth lost 12 aircraft that day. Rosie's men were the only ones to come back! After recuperation leave, they resumed their missions, which they completed on March 5, 1944, by then in their new B-17G Rosie's Riveters (II). The original B-17F Rosie's Riveters was assigned to the crew of Lt. Ross E. McPhee. They renamed the B-17F Satcha Lass and were shot down with her on February 4, 1944, during a raid on Frankfurt. Robert Rosenthal became one of the 100th BG's greatest legends, flying 52 combat sorties, being shot down twice and being twice squadron commander. After the war he was an investigator at the Nuremberg Trials and later a founding member of the 100th BG veterans organization.

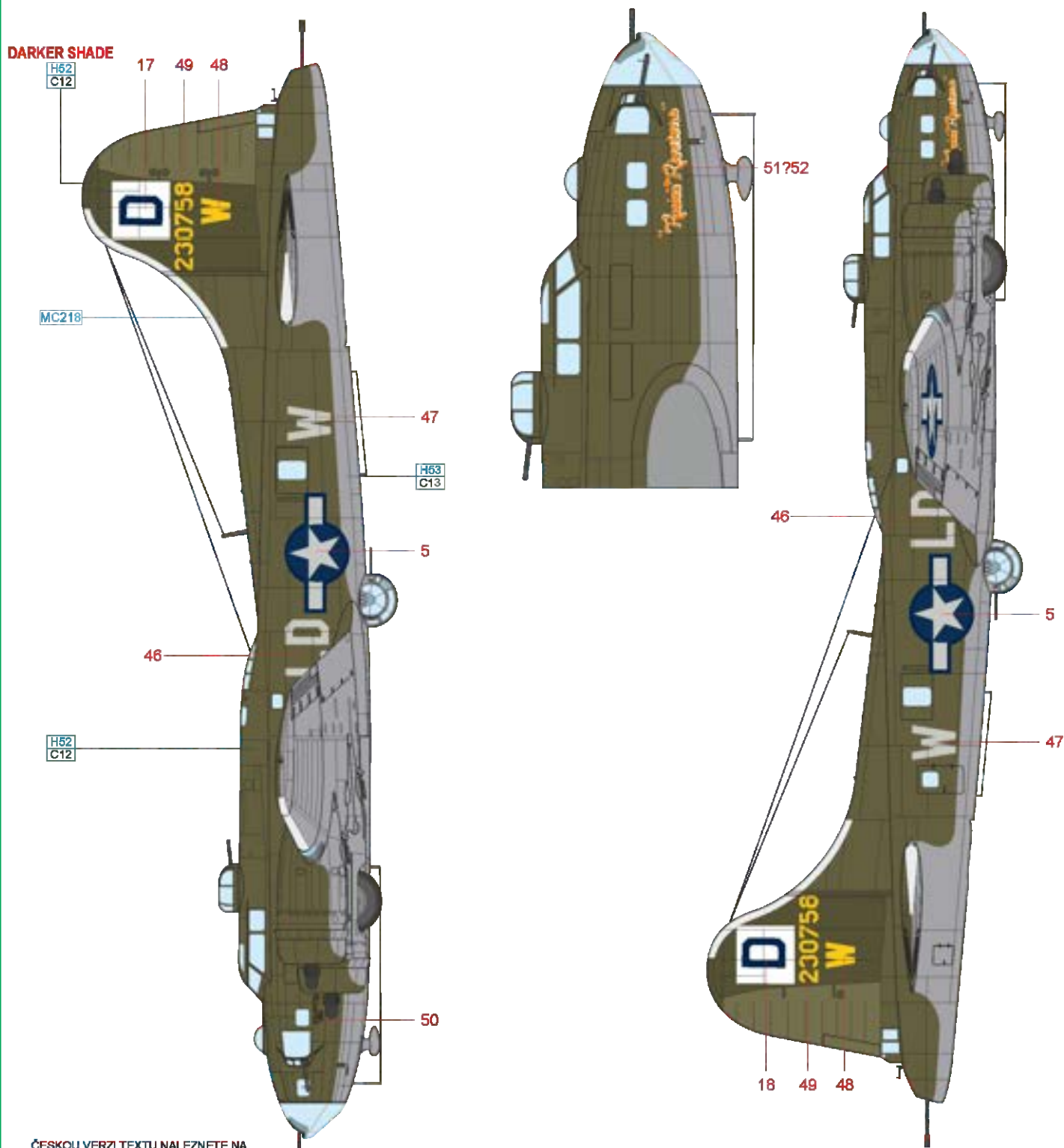

ČESKOU VERZI TEXTU NALEZNETE NA
www.eduard.com
 POD KATALOGOVÝM ČÍSLEM 11183



FLAT BLACK	H12 C33	YELLOW	H329 C329	ALUMINUM	MC218
OLIVE DRAB	H62 C12	NEUTRAL GRAY	H53 C13	CHROME SILVER	MC211

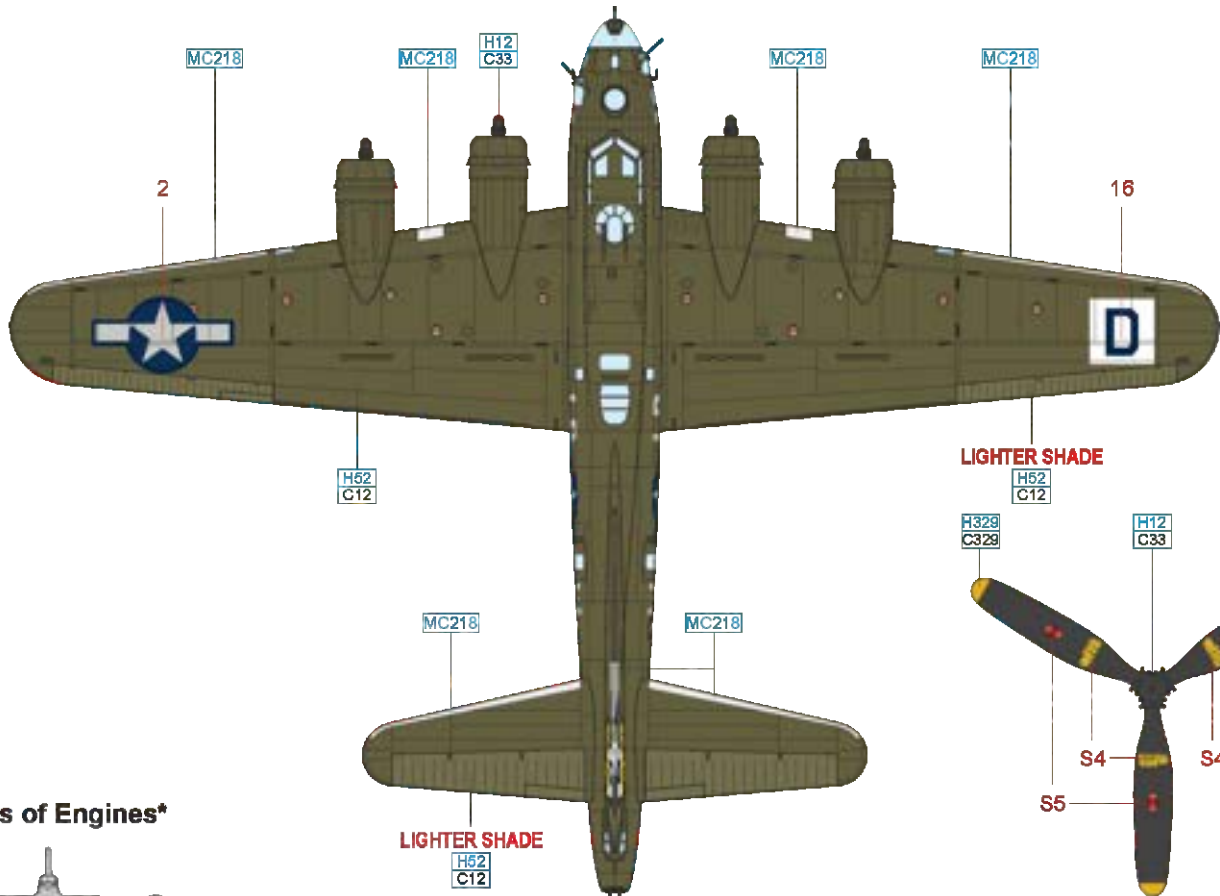

LIGHTER SHADE

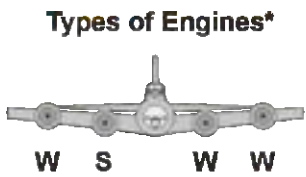
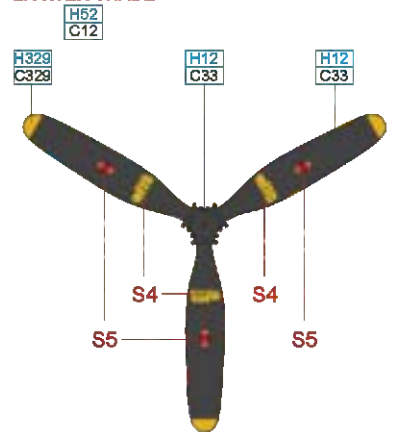

* Letter W for Wright Engine
Letter S for Studebaker Engine

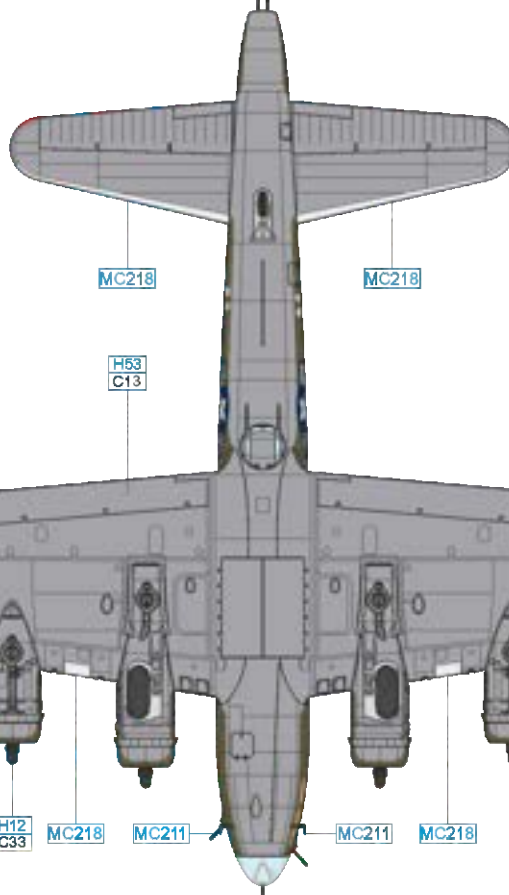

ČESKOU VERZI TEXTU NALEZNETE NA
www.eduard.com
POD KATALOGOVÝM ČÍSLEM 11183



G B-17F-45-DL, 42-3307, Maj. Ollen O. Turner, Lt. Jack R. Swartout crew, 351st BS, 100th BG, Thorpe Abbots, United Kingdom, July 1943

B-17F, 42-3307, later named Skipper, was not among the aircraft in which the unit moved to Thorpe Abbots, although it arrived there before the Hundredth started their combat missions. Skipper was thus able to take part in the unit's second mission on June 26, 1943. She was chosen as personal aircraft by the 351st Bomb Squadron commander, Maj. Ollen O. Turner. The new B-17 was named after Turner's wife's nickname, although the nickname soon transferred to Maj. Turner himself. The depicted profile places the aircraft in its early period of service, when the 100th BG had completed the first ten of its more than 300 combat missions. The aircraft does not yet bear any marks of missions flown, although it had flown several during this period. The anti-icing features have been retained on all positions and the propeller hubs are black. The aircraft, like other machines in the care of T/Sgt. Dewey R. Christopher's ground crew, had white main landing gear wheel covers and a white painted tail wheel disc. At this early period, Skipper did not yet have armor glass installed in the cockpit windows. The navigation loop antenna cover under the nose of the aircraft bore a decorative white and red spiral.

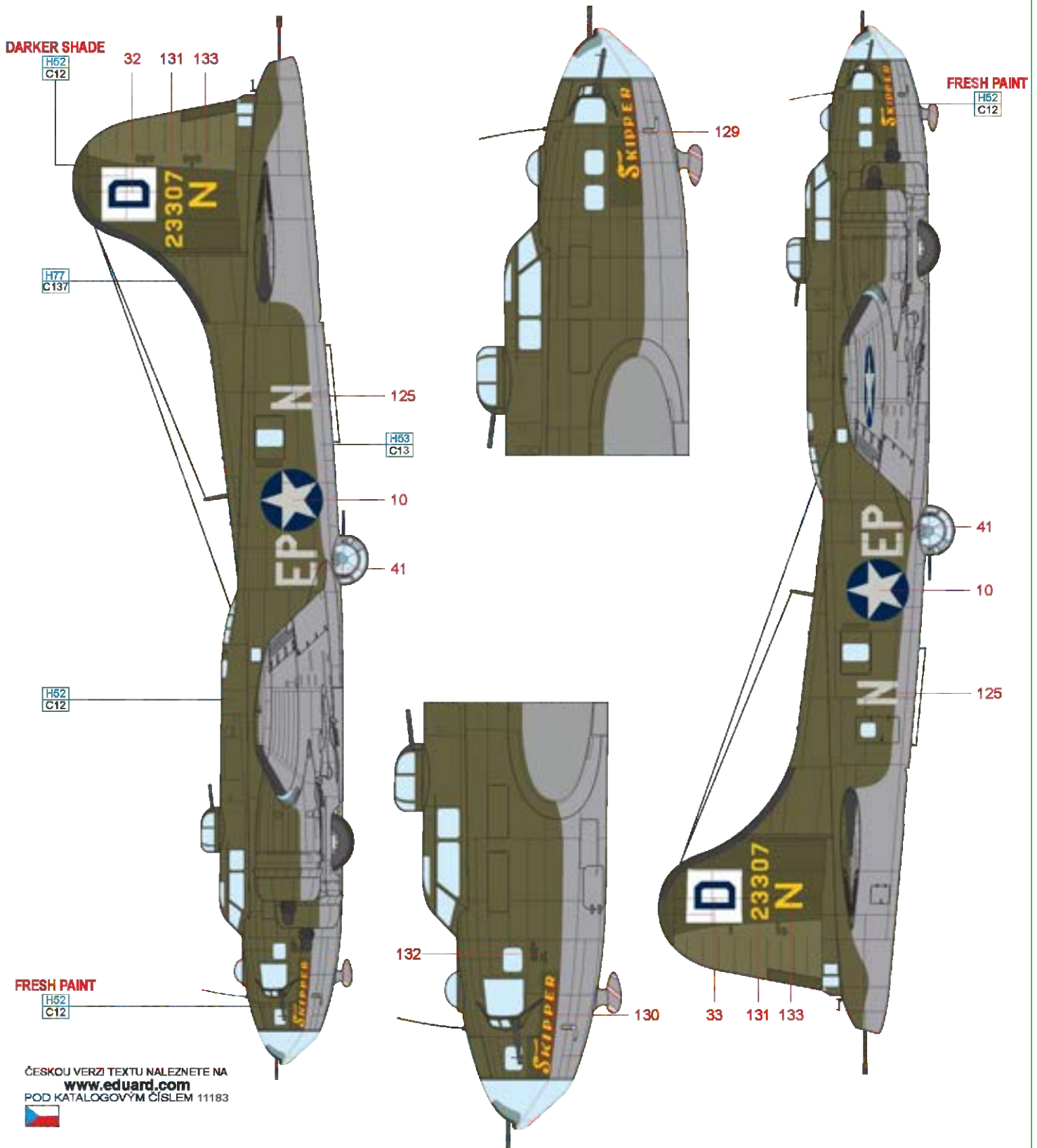

ČESKOU VERZI TEXTU NALEZNETE NA
www.eduard.com
 POD KATALOGOVÝM ČÍSLEM 11183



FLAT BLACK	H12	YELLOW	H329	SILVER	H8
	C33		C329		C8
OLIVE DRAB	H52	NEUTRAL GRAY	H53	TIRE BLACK	H77
	C12		C13		C137
				CHROME SILVER	MC211

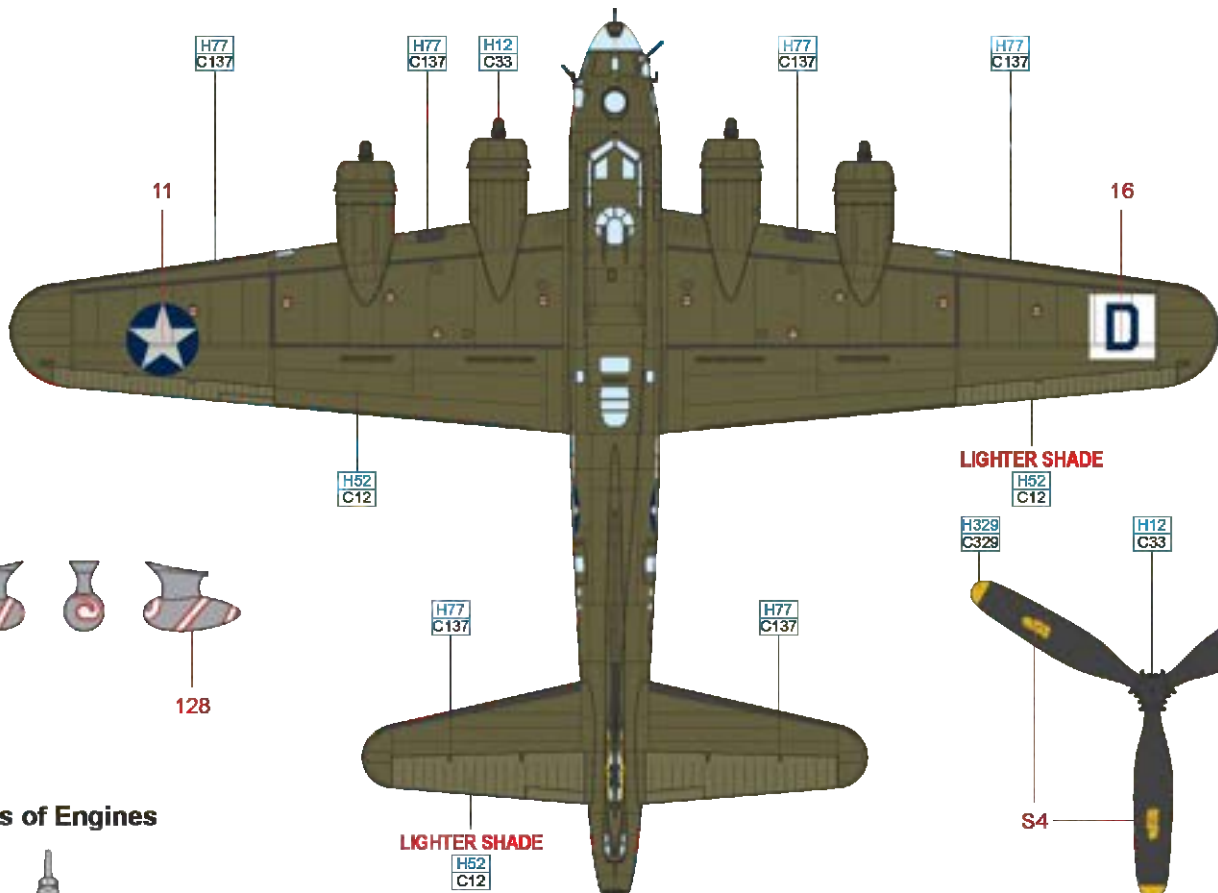

Types of Engines

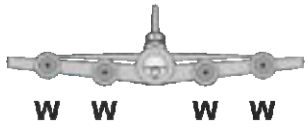

* Letter W for Wright Engine
Letter S for Studebaker Engine

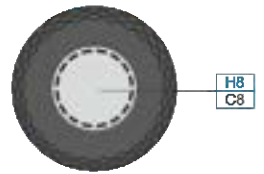

ČESKOU VERZI TEXTU NALEZNETE NA
www.eduard.com
POD KATALOGOVÝM ČÍSLEM 11183

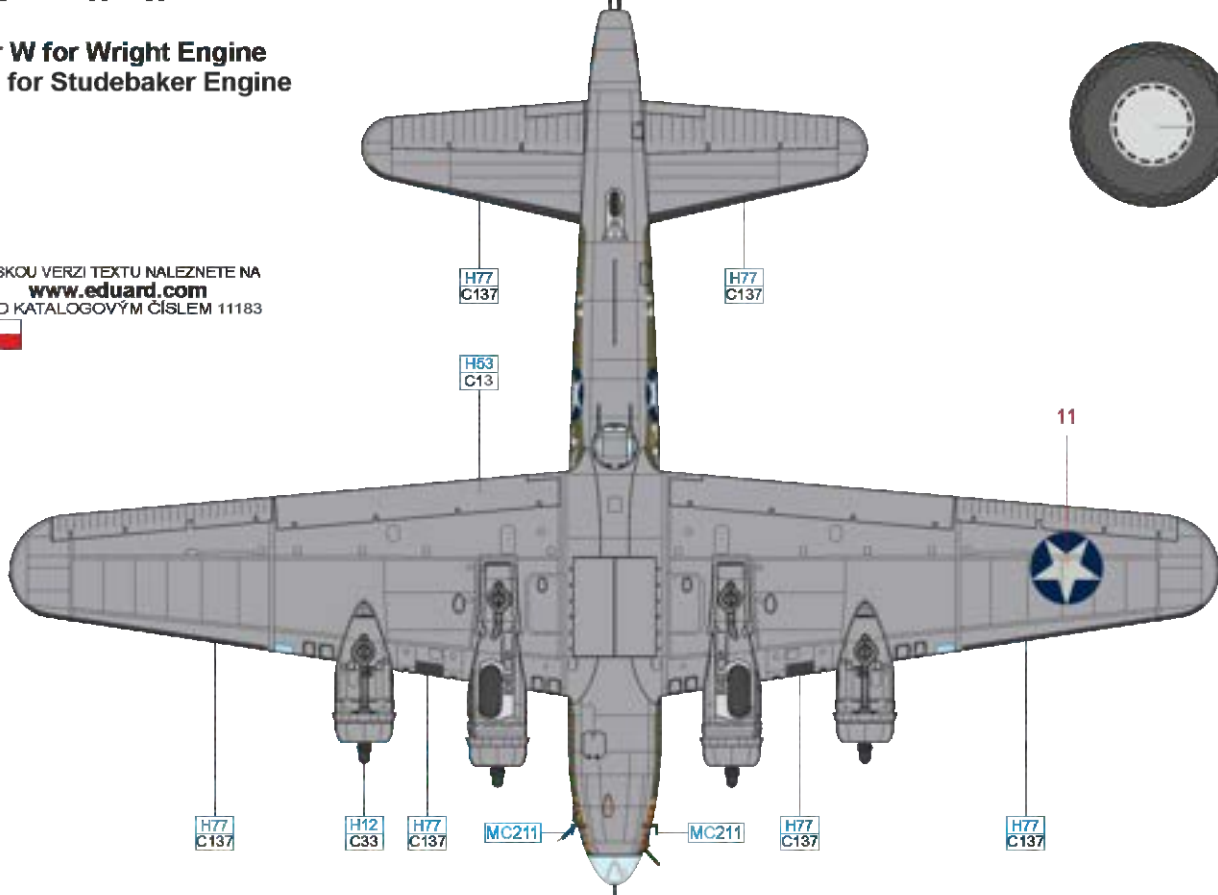

H B-17F-45-DL, 42-3307, Lt. Arch J. Drummond crew, 351st BS, 100th BG, Thorpe Abbots, United Kingdom, late 1943

In the following months, Skipper flew several combat missions. His main users were the crew of Lt. Jack R. Swartout, who often flew with Maj. Turner, the squadron CO, when he participated in missions as a commanding pilot. Jack Swartout later left the crew to become CO of the 350th BS. He was succeeded by co-pilot Lt. Archie J. Drummond. During this period, the aircraft's insignia was repainted twice and the squadron identification letters on the fuselage were also moved during the first change. The aircraft received armored cockpit glass and with the radio equipment improvements, a rod antenna was added to the nose. On November 5, Skipper was severely damaged in the attack on Gelsenkirchen and underwent extensive repairs. At the end of 1943 she bore the symbols of 14 missions and 2 aerial victories. On January 24, 1944, Skipper was destroyed in an accident shortly after takeoff, when Lt. Drummond was trying to avoid a collision with a passing B-24. The ground crew was given a new B-17G as a replacement, which they named Skipper II. Today, Skipper III, a KC-135R Stratotanker from the 100th ARW USAF, flies out of Mildenhall AFB, so named in honor of the original Skipper's ground crew chief, Dewey R. Christopher.

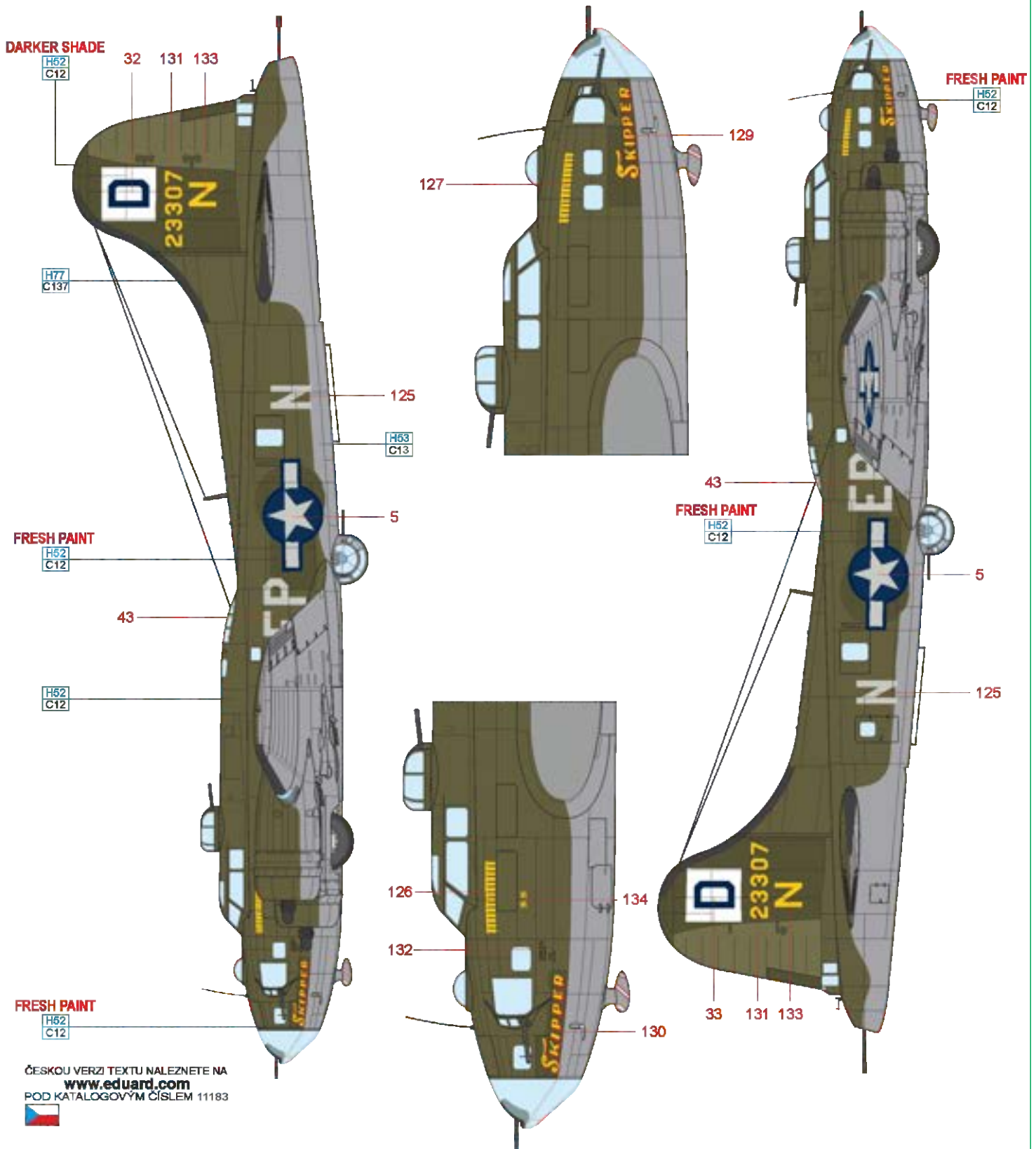

ČESKOU VERZI TEXTU NALEZNETE NA
www.eduard.com
 POD KATALOGOVÝM ČÍSLEM 11183



FLAT BLACK	H12 C33	YELLOW	H329 C329	SILVER	H8 C8
OLIVE DRAB	H52 C12	NEUTRAL GRAY	H53 C13	TIRE BLACK	H77 C137
				CHROME SILVER	MC211

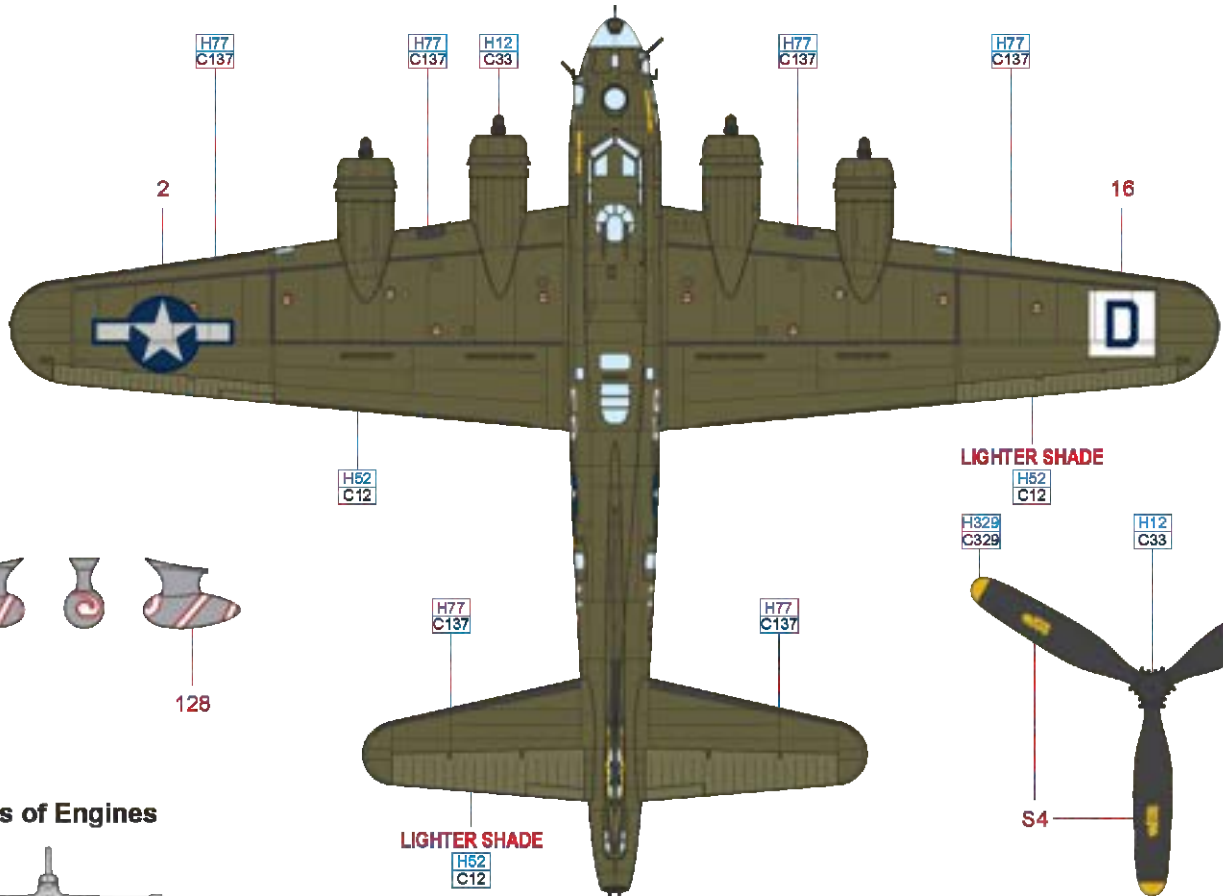

Types of Engines

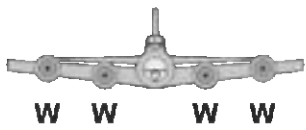

* Letter W for Wright Engine
Letter S for Studebaker Engine

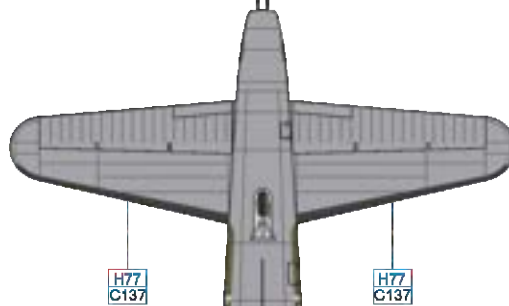

ČESKOU VERZI TEXTU NALEZNETE NA
www.eduard.com
POD KATALOGOVÝM ČÍSLEM 11183

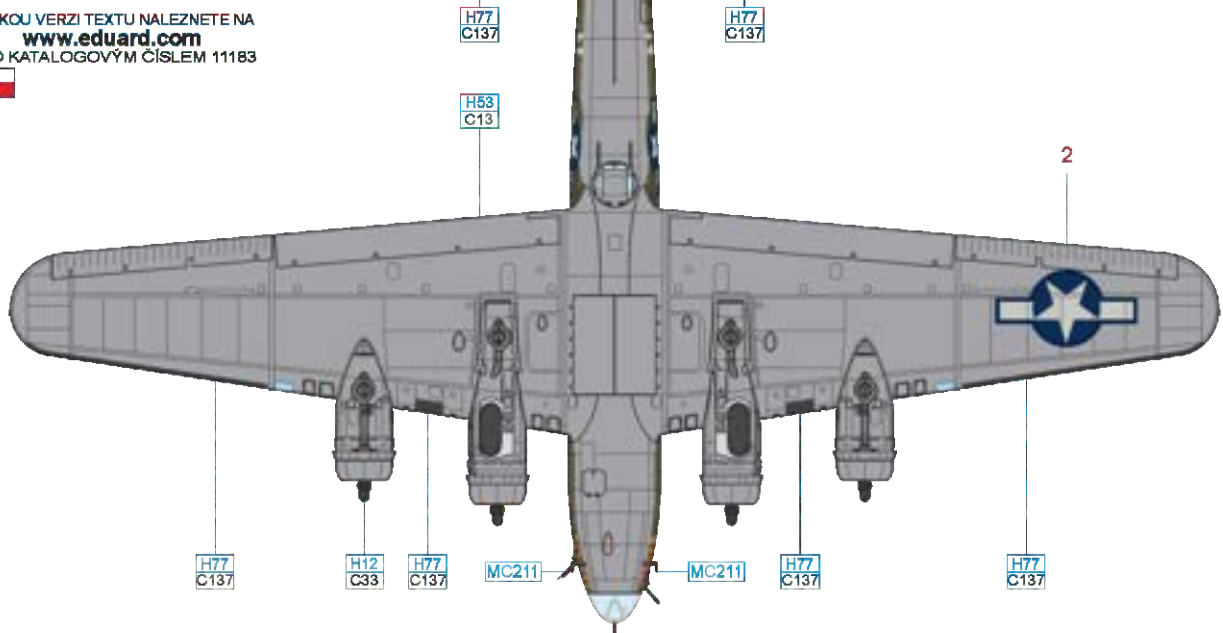

B-17F-40-VE, 42-5957, crews of Lt. Sumner H. Reeder, Lt. Henry M. Henington, 349th BS, 100th BG, Thorpe Abbots, United Kingdom, early 1944

The fate of Horny II, like the trial of her crews, was very turbulent. She returned from her first mission on September 6, 1943, with a dead co-pilot and seriously wounded pilot, bombardier and navigator. On a mission to Stuttgart that day, this B-17 was flown by the crew of Lt. Sumner H. Reeder, who, wounded himself, was still able to return to England. The aircraft was repaired and assigned to the crew of Lt. Henry M. Henington. Their first mission with it was a raid on Bremen, on October 8, 1943, one of the worst days of the Bloody Hundredth. Horny II again returned from the mission with only two working engines. Henington's crew completed their operational tour of 25 missions in late 1943, flying a large portion of them in this aircraft. The last mission of Henington's team took place on December 31, 1943. The target was Paris, and Horny II returned again with only two working engines, and with flat tires. During the winter and early spring of 1944, the number of missions climbed to nearly fifty. On May 9, 1944, while washing oil on the wing, an electrical discharge caused gasoline to ignite, and Horny II was destroyed. However, in 49 missions, she was always able to bring her crews home, despite considerable damage.

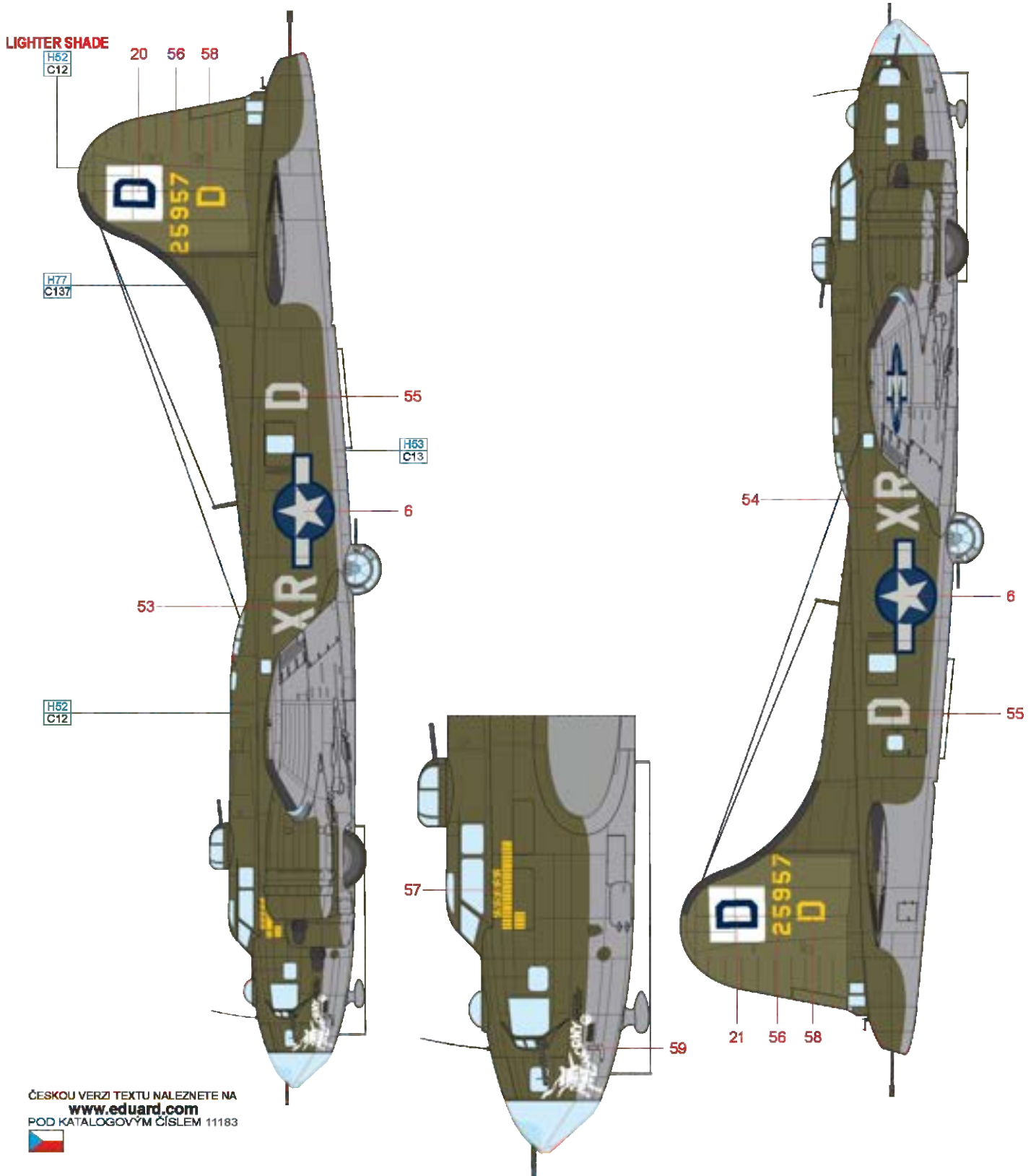

ČESKOU VERZI TEXTU NALEZNETE NA
www.eduard.com

POD KATALOGOVÝM ČÍSLEM 11183



FLAT BLACK	H12 C33	YELLOW	H329 C329
OLIVE DRAB	H52 C12	NEUTRAL GRAY	H53 C13
		TIRE BLACK	H77 C137
		CHROME SILVER	MC211

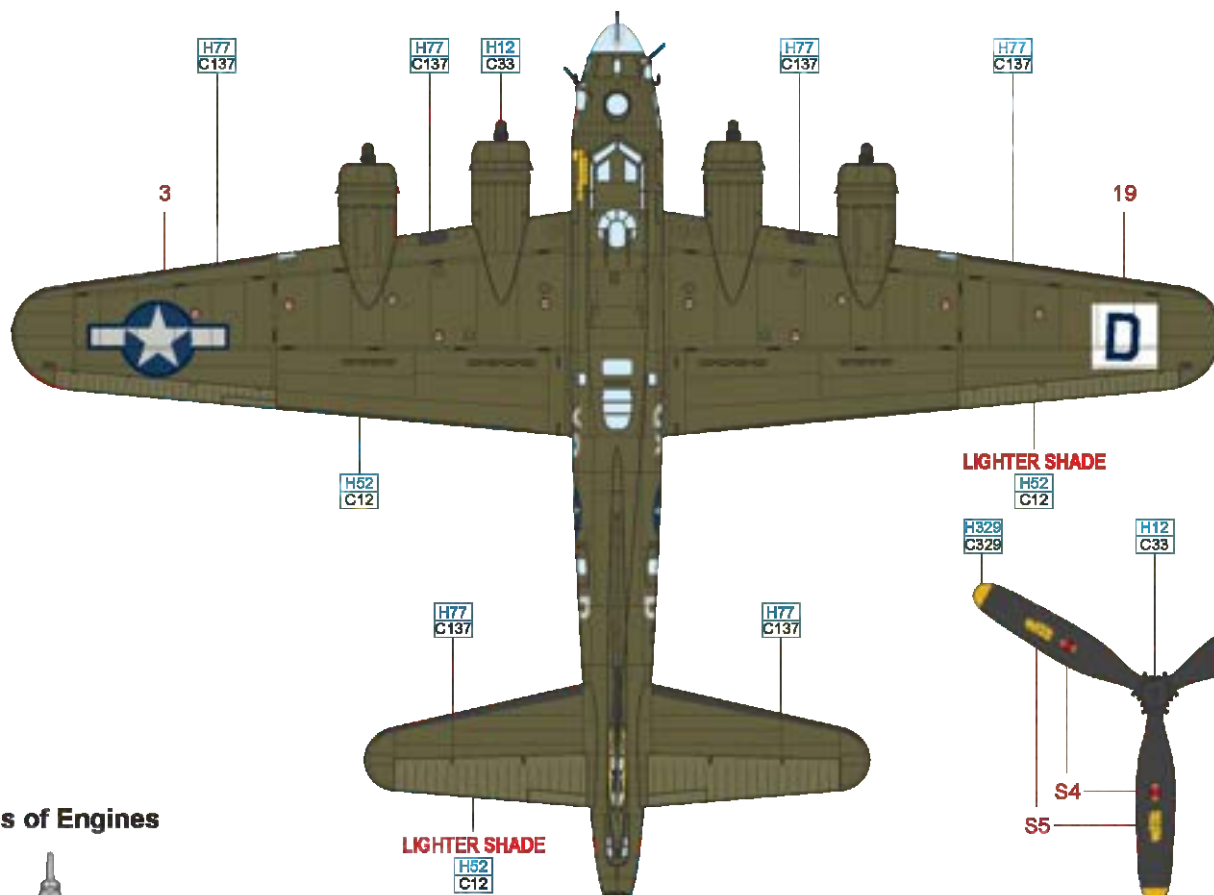

LIGHTER SHADE

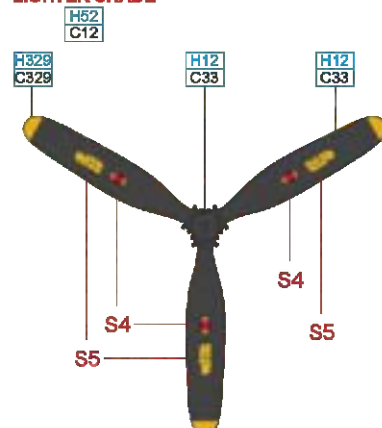

Types of Engines



* Letter W for Wright Engine
Letter S for Studebaker Engine

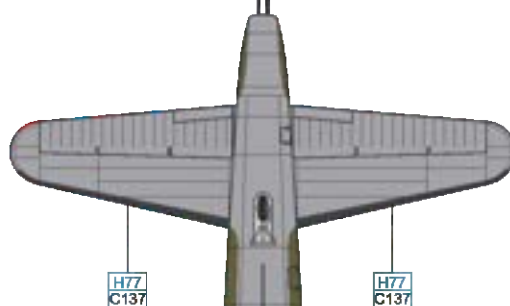

ČESKOU VERZI TEXTU NALEZNETE NA
www.eduard.com
POD KATALOGOVÝM ČÍSLEM 11183

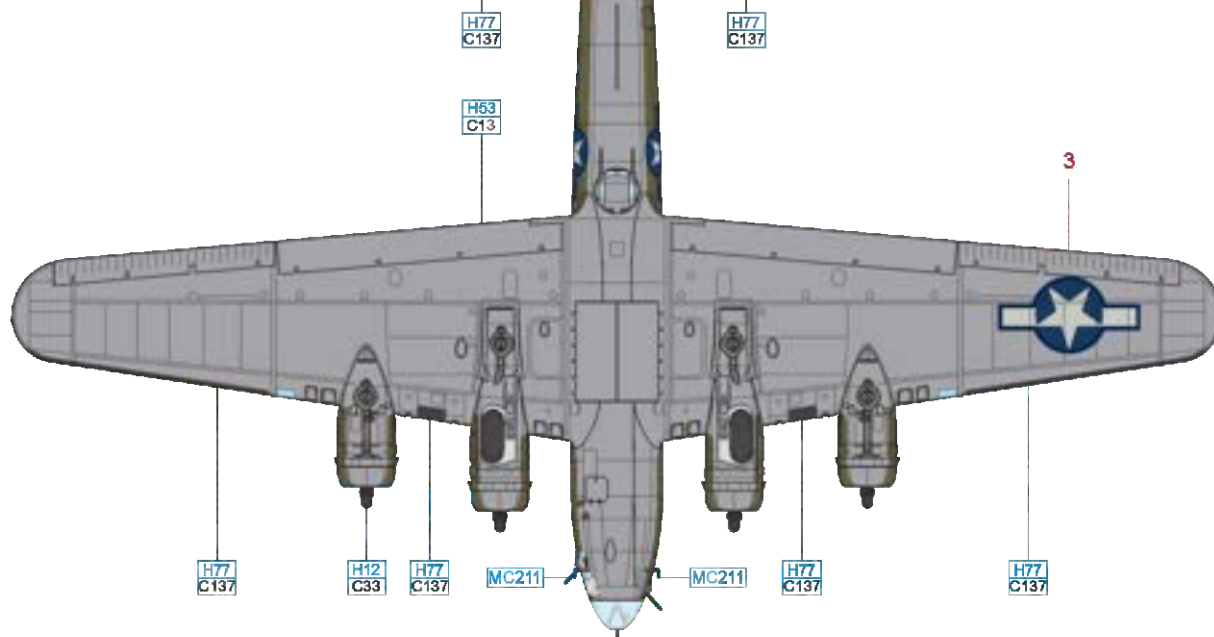

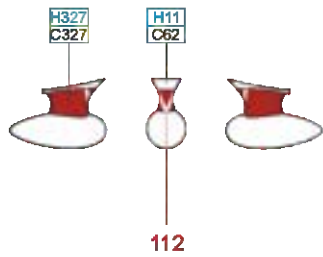
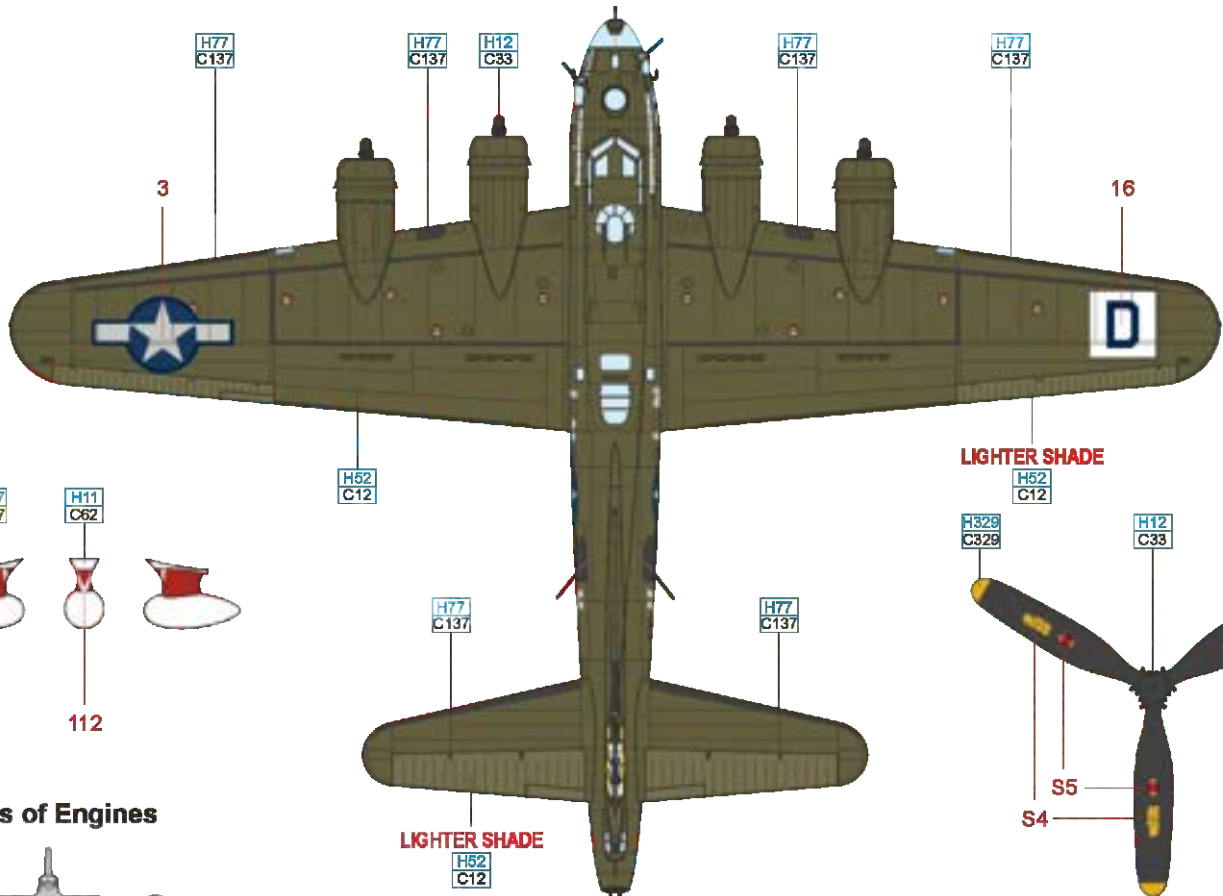

Types of Engines

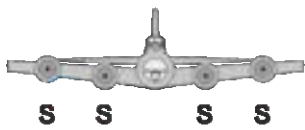

* Letter W for Wright Engine
Letter S for Studebaker Engine

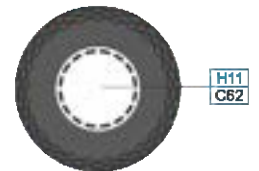
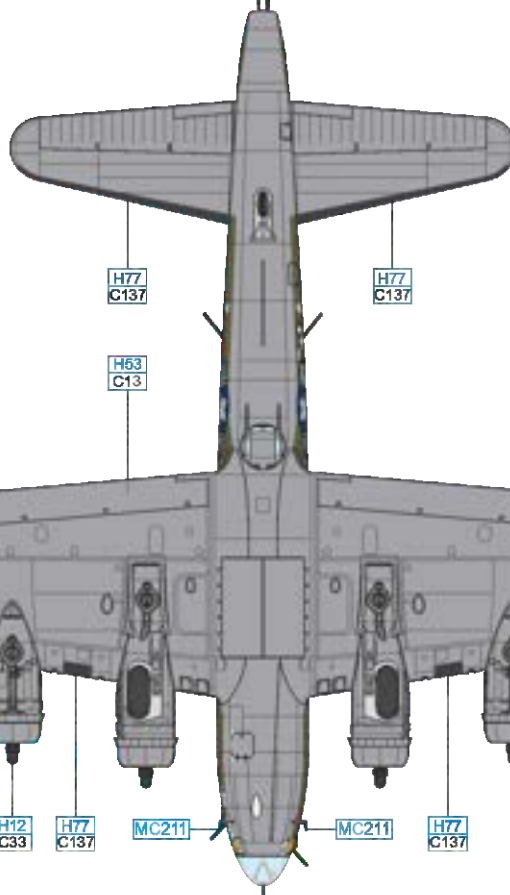

ČESKOU VERZI TEXTU NALEZNETE NA
www.eduard.com
POD KATALOGOVÝM ČÍSLEM 11183



K B-17F-55-DL, 42-3413, Lt. Albert E. Trommer crew, 350th BS, 100th BG, Thorpe Abbots, United Kingdom, July 1944

After Giles' crew's last mission in Hard Luck, on May 8, 1944, the aircraft was due for an overhaul with engine change. In 50 missions, she flew a total of 630 hours with the original engines and turbochargers, with which she had flown overseas in the summer of 1943. She also received new glass nose, closed waist windows and a top turret from a B-17G. At this time, the front of the prop hubs were decorated with white paint and the "D" on the rudder and wing repainted black. The three swastikas were now painted on a yellow background. After repairs, she returned to combat activity on July 8, 1944, with crew of Lt. Albert E. Trommer. During upcoming weeks, they flew 8 combat missions together. One cannot write about the Hard Luck and not mention her flight crew chief, the distinctive M/Sgt. Glenn M. "Zip" Myers, to whom, among others, the aircraft owes its long combat career. On August 14, 1944, for her 62nd mission she flew with the crew of Lt. Donald E. Cielewich, to Ludwigshafen, over which she was severely damaged by flak. The crew salvaged bombs and the B-17F started descending in a wide turn. Before crash, she allowed all the men to leave on parachutes. Hard Luck was by then the last B-17F to fly combat with the 100th BG.

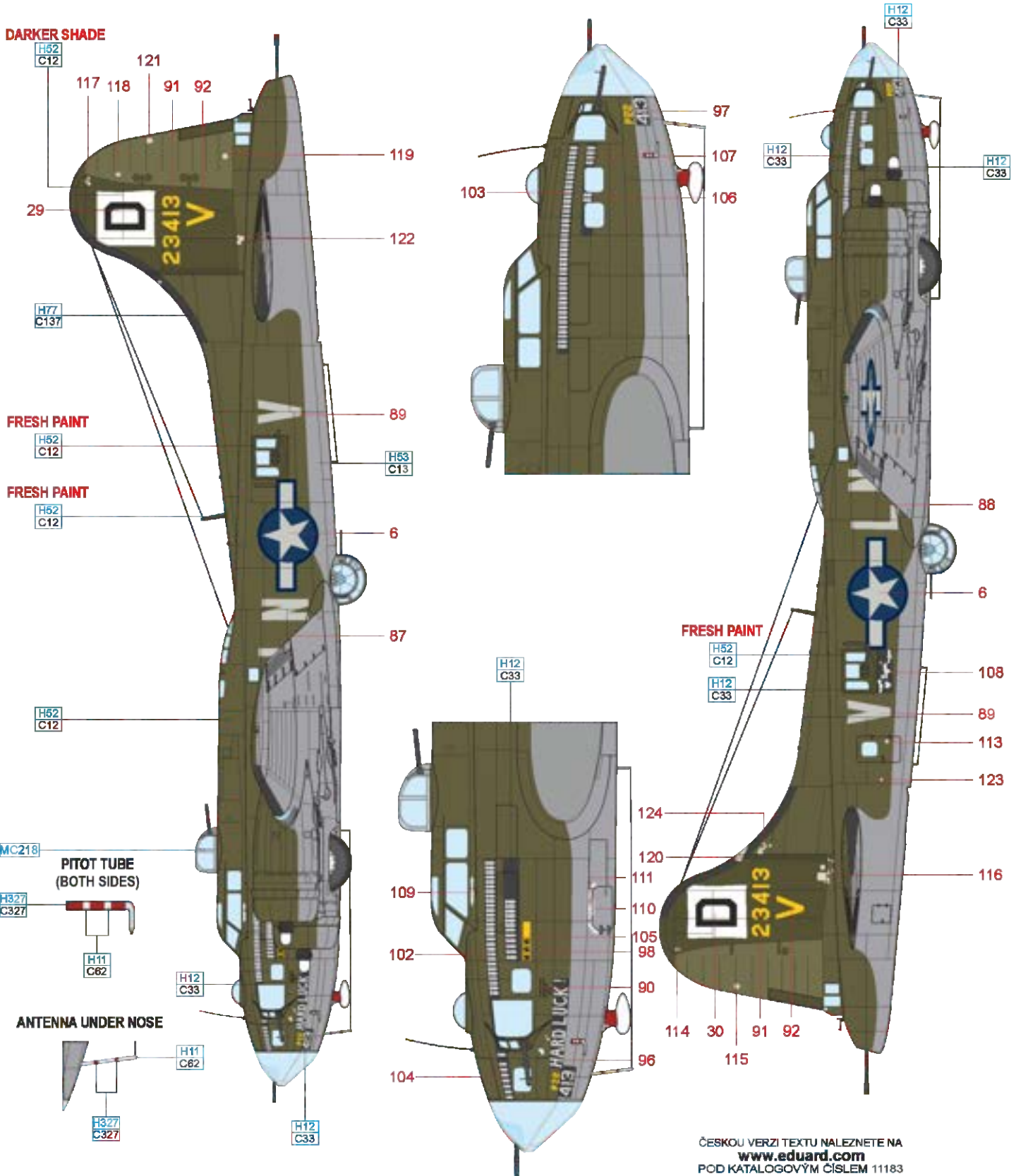

ČESKOU VERZI TEXTU NALEZNETE NA
www.eduard.com
 POD KATALOGOVÝM ČÍSLEM 11183



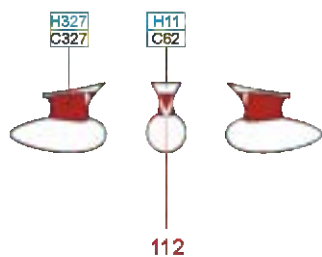
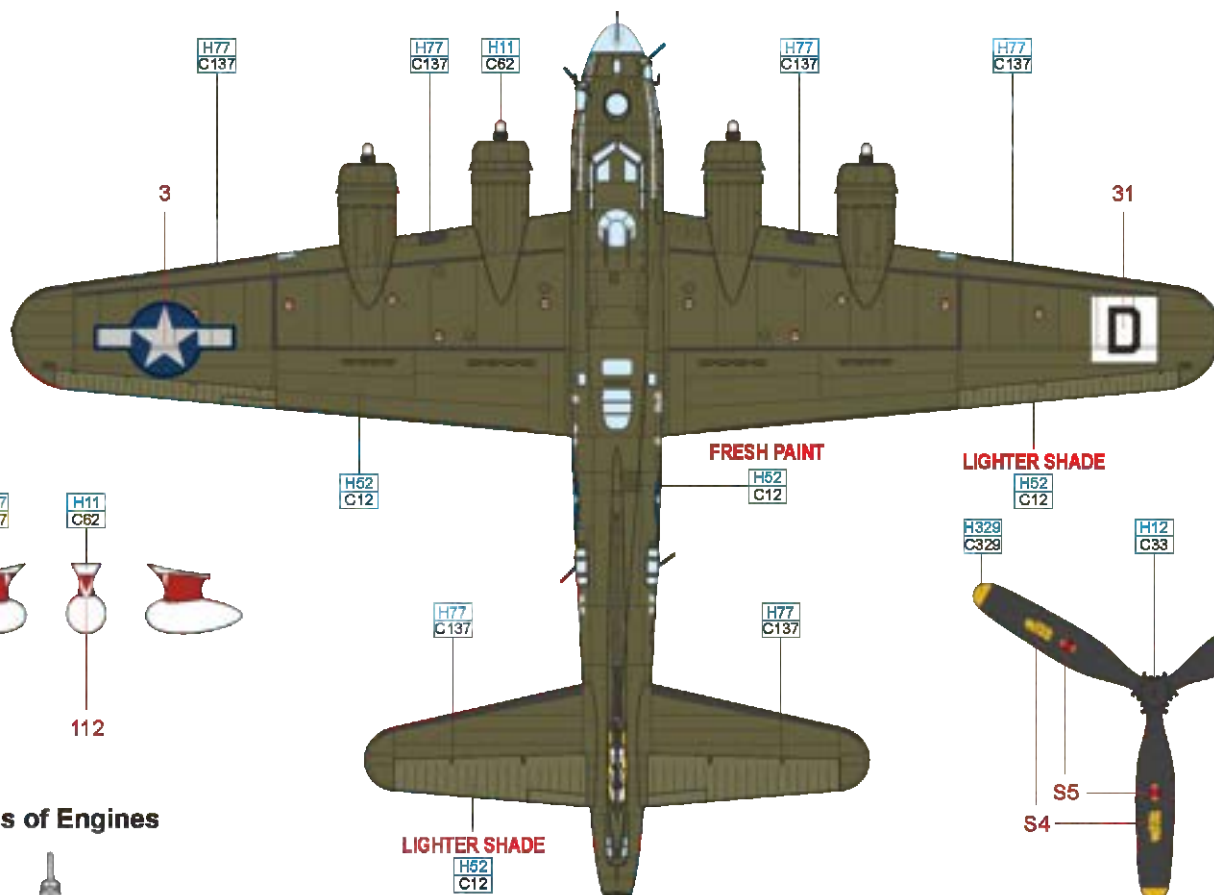

FRESH PAINT

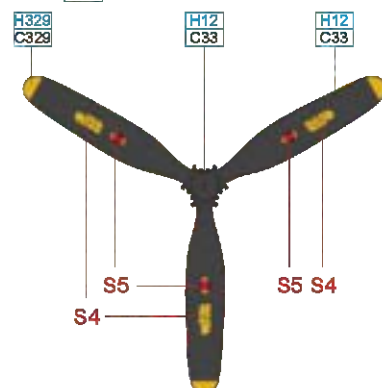

Types of Engines



* Letter W for Wright Engine
Letter S for Studebaker Engine

LIGHTER SHADE

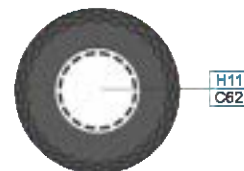
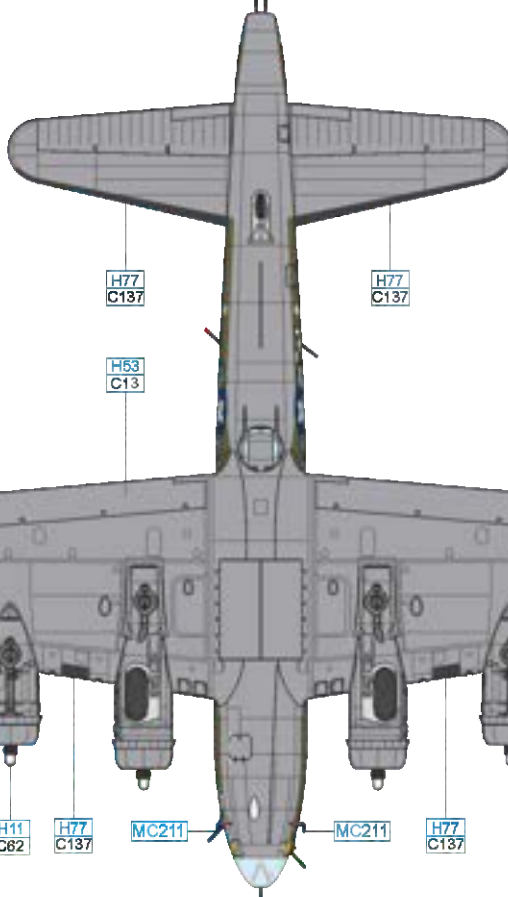

ČESKOU VERZI TEXTU NALEZNETE NA
www.eduard.com

POD KATALOGOVÝM ČÍSLEM 11183



WALKWAYS DECALS S24 FOR MARKINGS A, B, C, D, E, F, I, ONLY

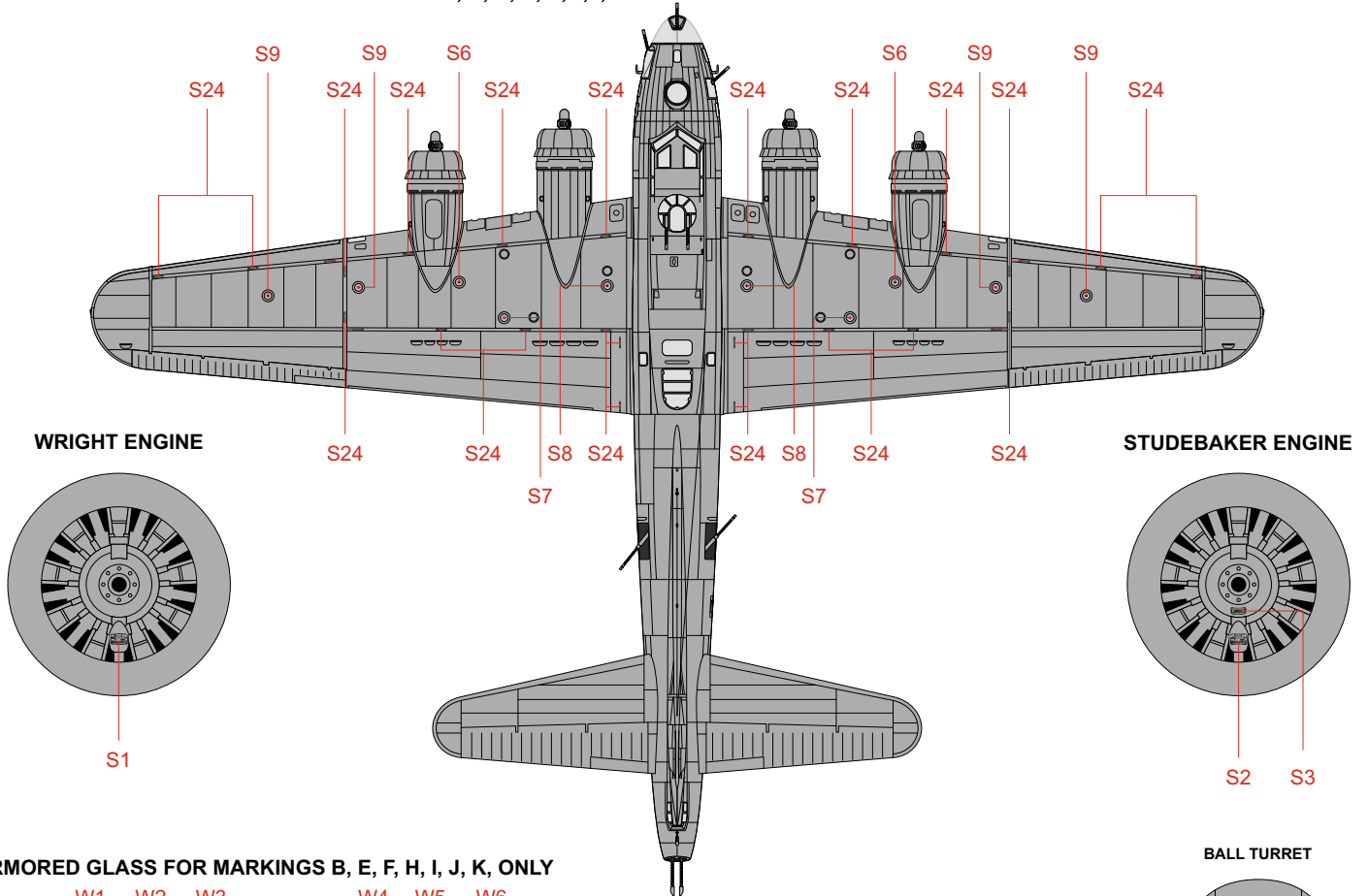

ARMORED GLASS FOR MARKINGS B, E, F, H, I, J, K, ONLY

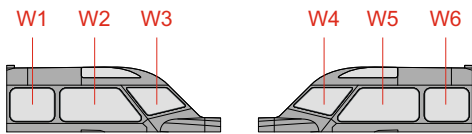

BALL TURRET

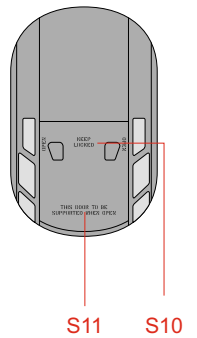

WALKWAYS FOR MARKINGS G, H, J, K, ONLY

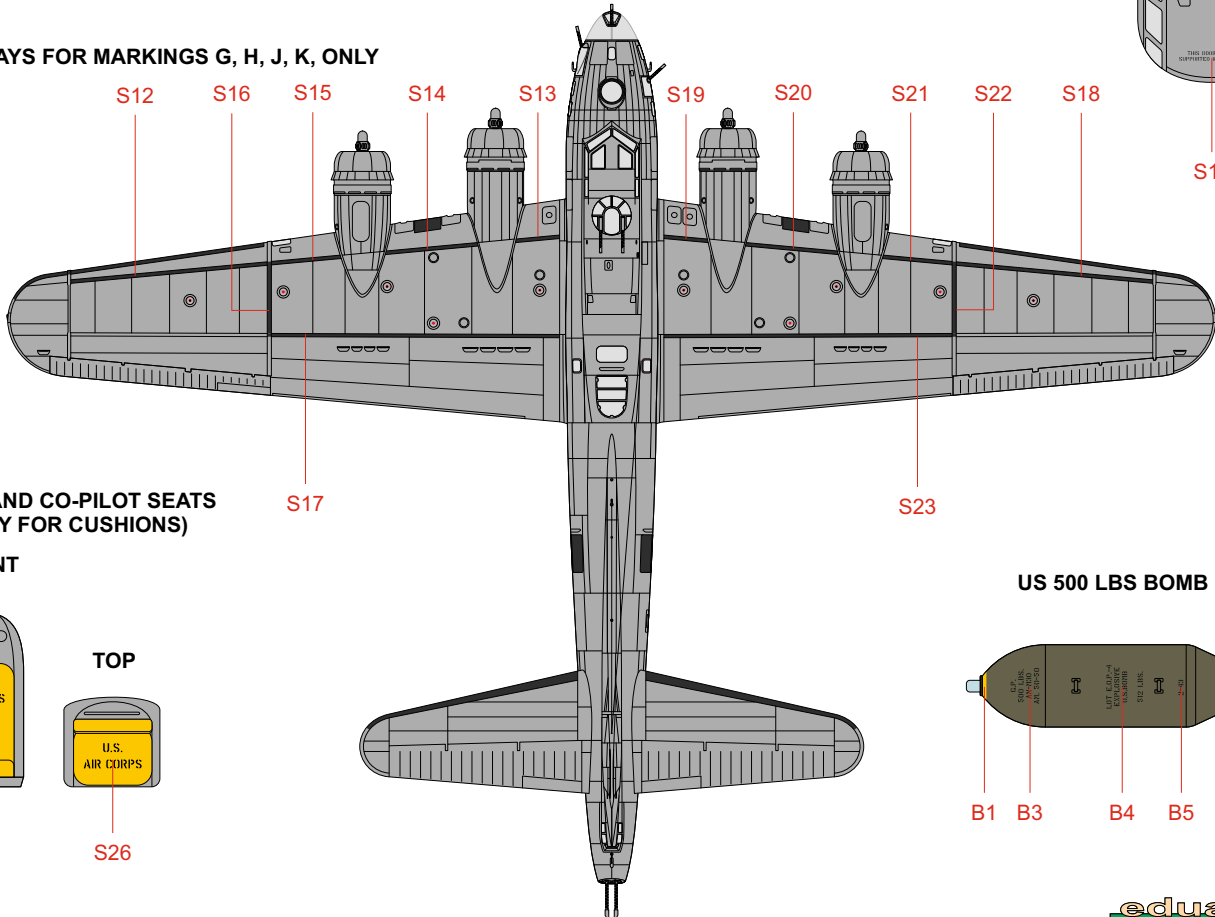

PILOT AND CO-PILOT SEATS (ONLY FOR CUSHIONS)

FRONT

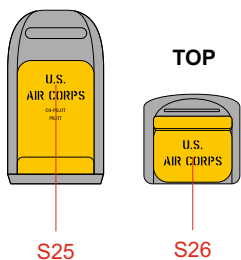

US 500 LBS BOMB

