

29



14th / 20th Kings Hussars
4th Armoured Brigade, Traf (UK) Armoured Division
Kuwait, February 1991



BC

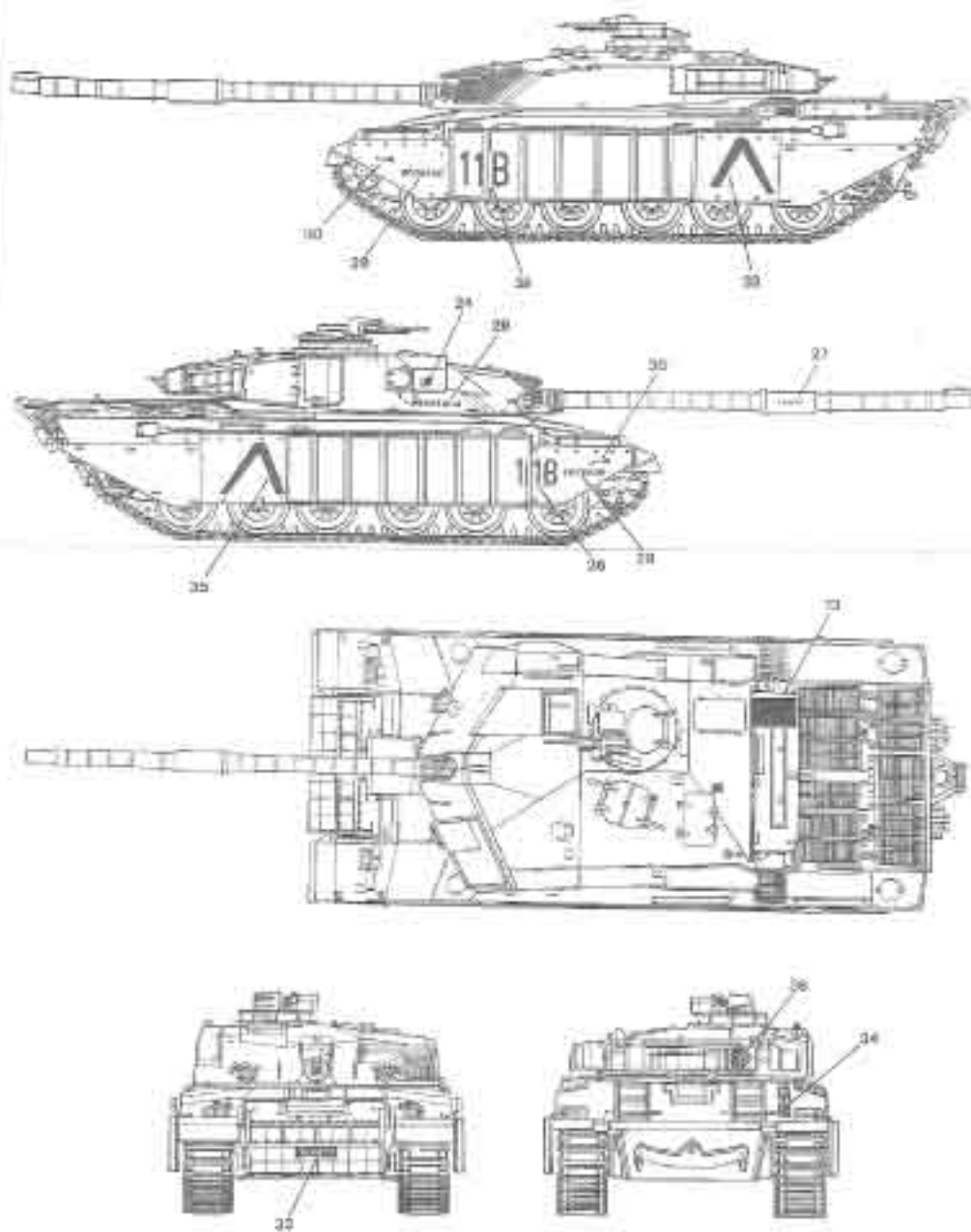

28



KRH Battle Group 'KFOR'
Podujevo, Kosovo, Juli 1998



AK

BK

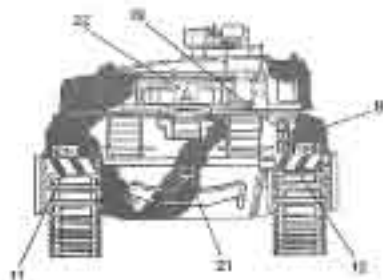
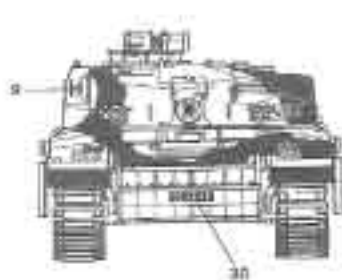

27



King's Royal Hussars, Battle Group
'KFOR'

Podujero, Kosovo, June 1999

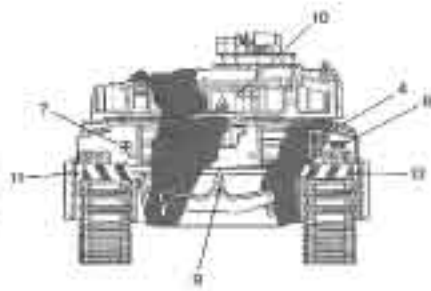
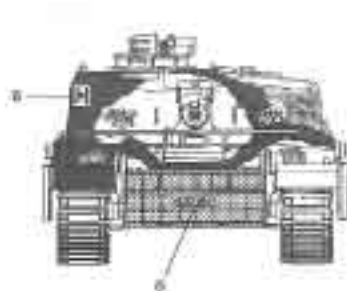

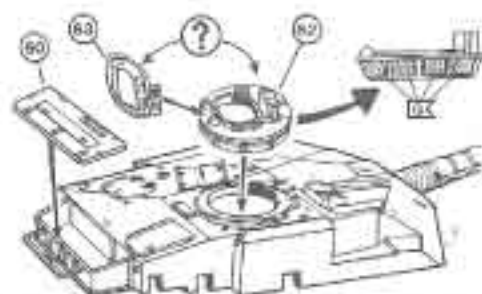
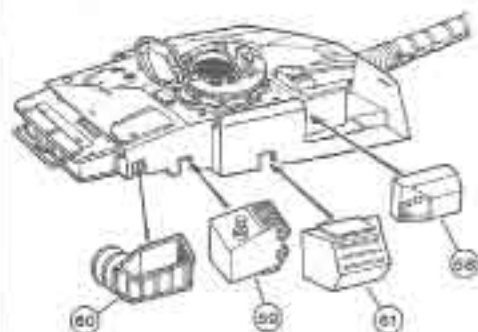
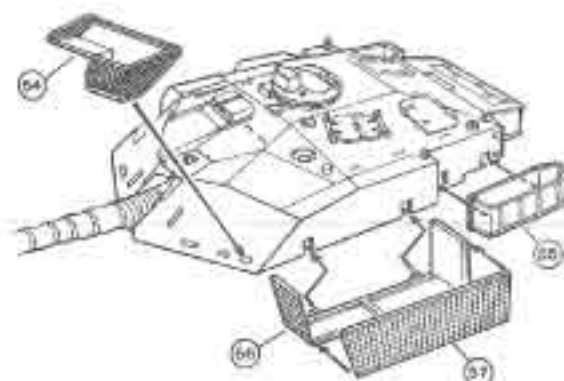
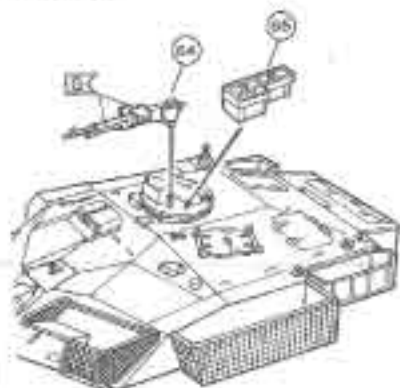
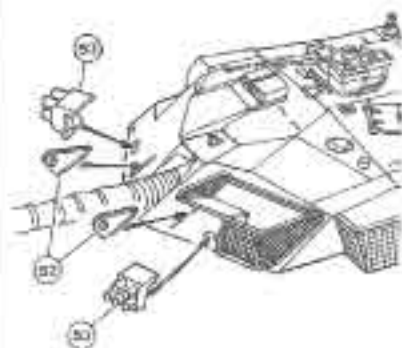
21 22 23 24 25 26 

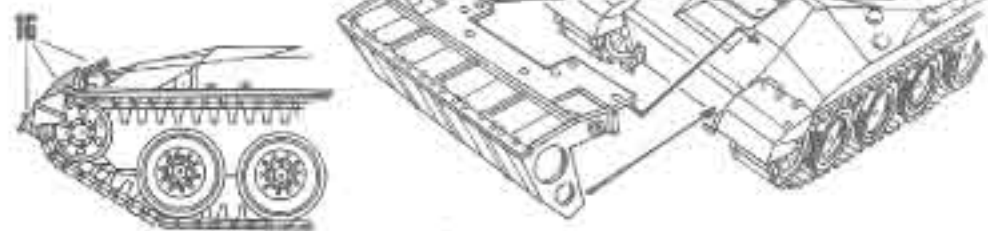
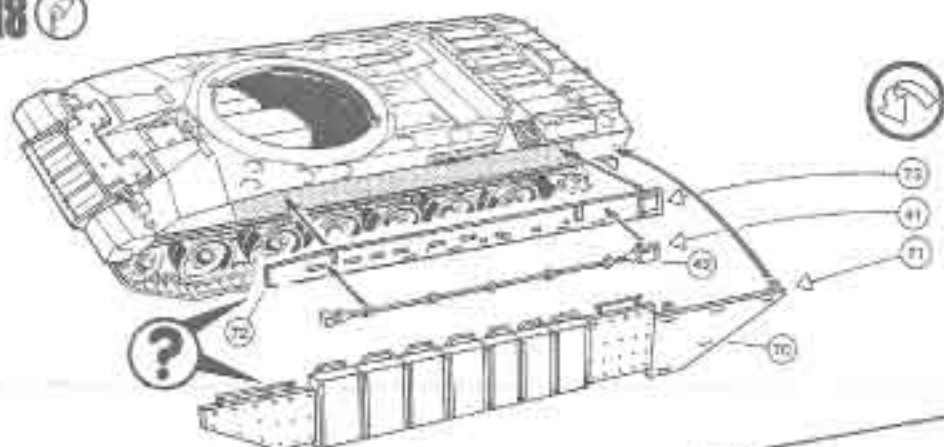
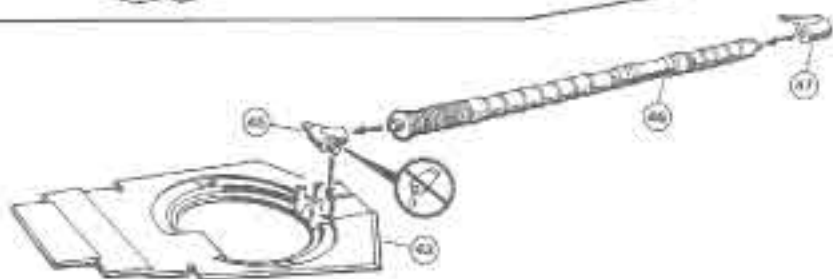
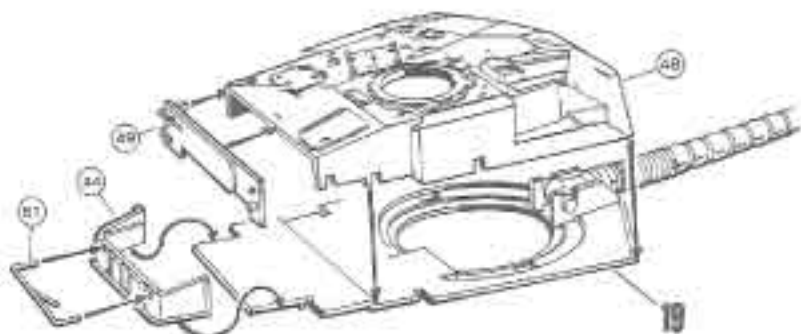
17 18 19 20 

10

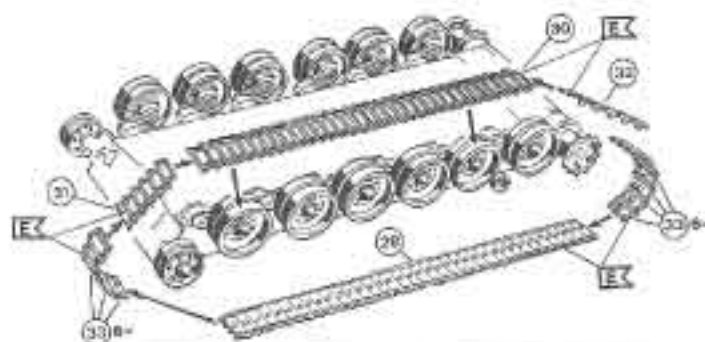

11

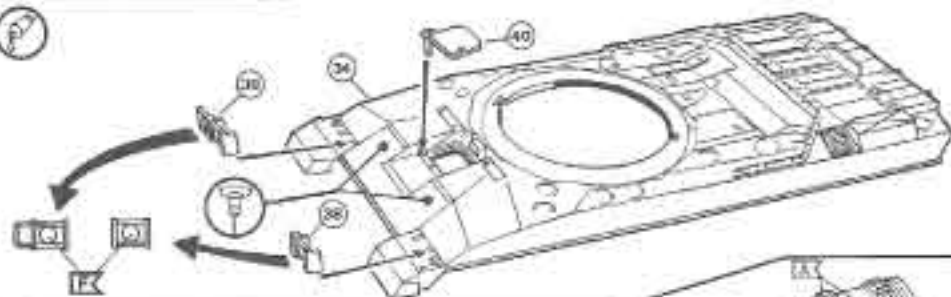

12

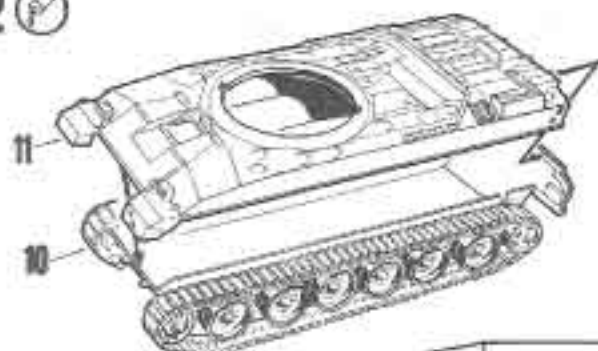

13

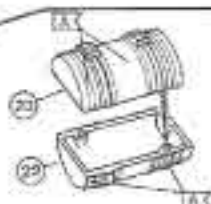

14



15

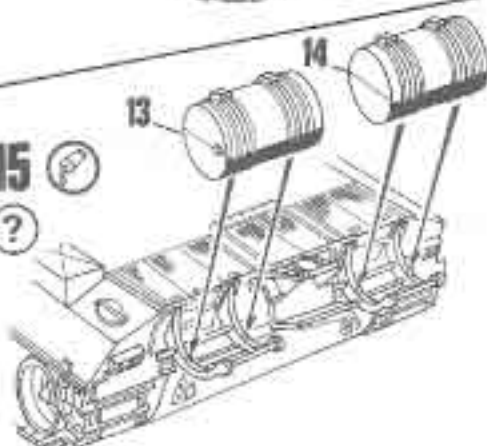

16

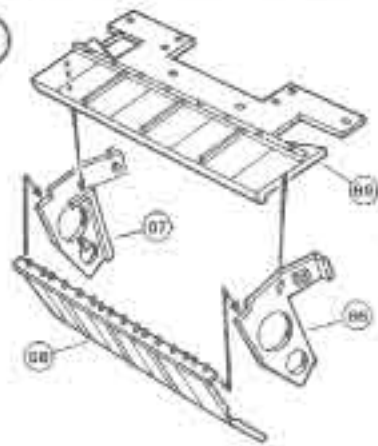

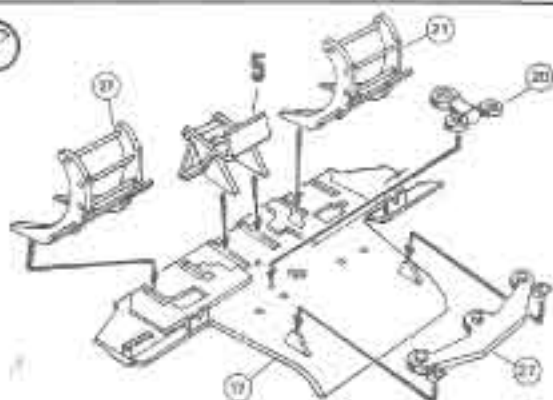
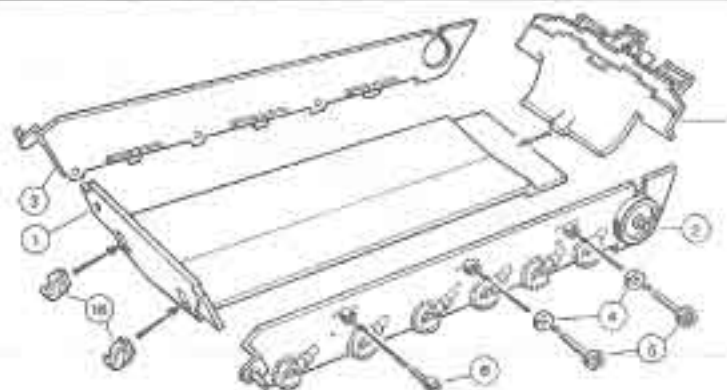
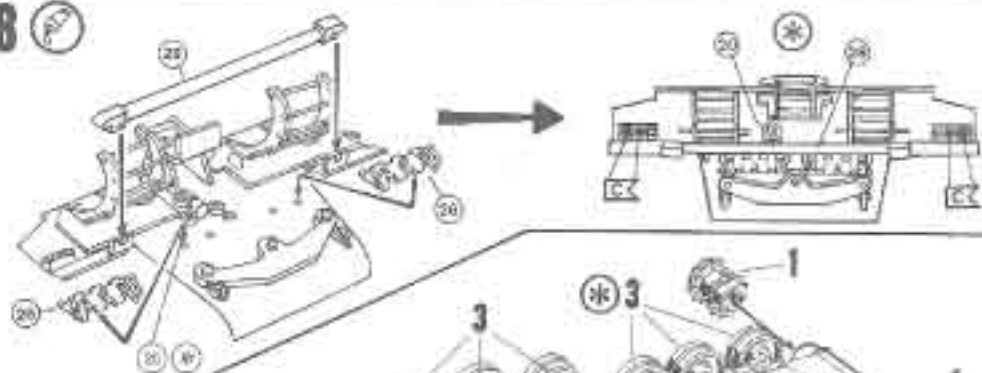
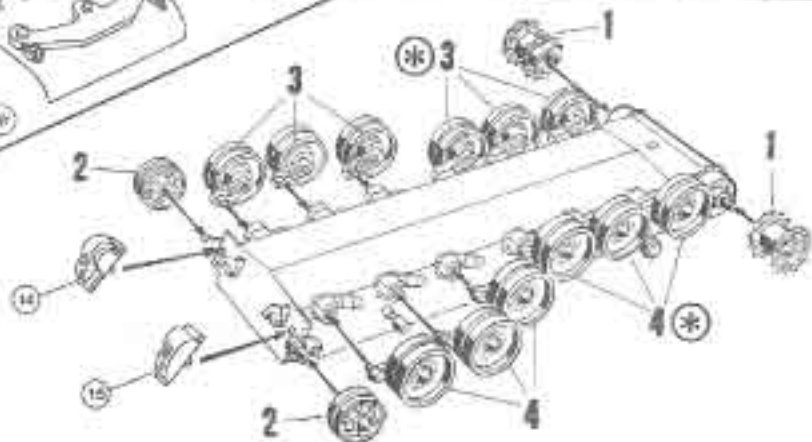
5 6 7 8 9 

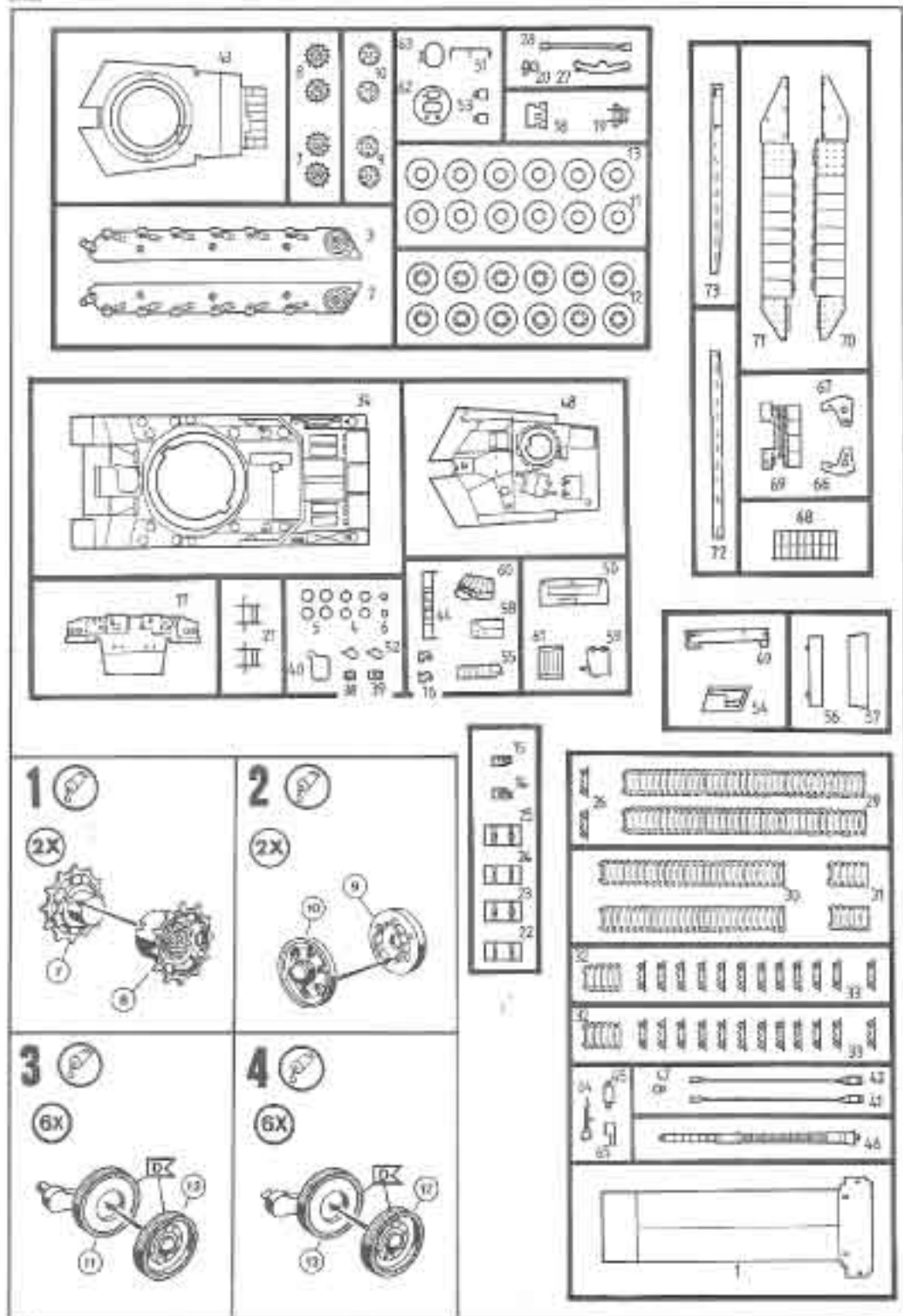



Handwritten text in German, oriented vertically on the right side of the page. The text appears to be a list of instructions or a guide related to the cursive writing diagrams. It includes phrases like "Schritt 1", "Schritt 2", "Schritt 3", "Schritt 4", and "Schritt 5", corresponding to the diagrams. The handwriting is in a cursive style, consistent with the diagrams.

Handwritten text in German, oriented vertically on the left side of the page. This text also appears to be part of a guide or instructions, possibly providing additional context or tips for the cursive writing practice. It includes phrases like "Handwritten text" and "Handwritten text".

Vor dem Zusammenstrich gut durchlesen! **Heut bevor you start!**