



1:24 Supermarine Spitfire Mk.VIII

A17002 SCALE MODEL CONSTRUCTION KIT | Wingspan: 469mm Fuselage Length: 402mm | Three Decal Schemes Included

EN Although the Spitfire is widely regarded as the most famous fighting aeroplane in the history of aviation, it's still incredible to think that an aircraft which made its first flight back in March 1936 is still the subject of such fascination to this day and how it remains familiar to millions of people the world over. Perhaps the most impressive feature associated with the enduring legacy of the Spitfire is how its basic design was able to be adapted and upgraded so effectively throughout the Second World War and how the final variants of this magnificent aircraft were far more capable than the ones which first arrived at RAF Duxford during the summer of 1938.

With the Spitfire undergoing almost constant development to enable it to stay at the forefront of fighter technology, this vital work was interrupted by the introduction of the Luftwaffe's fearsome new Focke Wulf Fw190 in 1941, an aircraft which was superior to the Spitfire Mk.V which was in widespread service at the time. A new Spitfire variant, the Mk.VIII, was at an advanced stage of development at the time, however, actual production was still some way off, as manufacturing jigs had not been installed in factories at that time. A stop-gap solution proved to be the introduction of the hybrid Mk.IX, an aircraft which fortunately proved to be something of a revelation and more than a match for the Focke Wulf.

The planned Spitfire Mk.VIII would continue into production and was essentially a fighter intentionally designed and engineered from the outset to be the next version

of the fighter and a major production variant. Powered by the latest variants of Merlin engine, the Mk.VIII featured a strengthened fuselage, retractable tail wheel and the adoption of a new broad-chord rudder, with versions optimised for high, medium and low altitude operations.

This variant of Spitfire served primarily with units based overseas, with the RAF in the Mediterranean, Middle and Far East and the RAAF in the South West Pacific. Many pilots who flew several marks of this famous fighter regarded the Mk.VIII as the best flying Spitfire of them all.

Specification

Maximum Speed: 404mph (650km/h) at 21,00ft (6,400m)

Range: 660 miles (1062 km)

Wingspan: 36 ft 10 in (11.23m)

Length: 31 ft 8.0 in (9.65 m)

Armament: 2 x 20mm Hispano Cannons. 4 x .303in (7.7mm) Browning Machine Guns

FR Bien que le Spitfire soit largement considéré comme l'avion de combat le plus célèbre de l'histoire de l'aviation, il reste difficile à croire qu'un avion qui a effectué son premier vol en mars 1936 fasse encore aujourd'hui l'objet d'une telle fascination et qu'il reste connu de millions de personnes dans le monde entier. La caractéristique la plus impressionnante associée à l'héritage persistant du Spitfire est peut-être la façon dont sa conception de base a pu être adaptée et améliorée de manière si efficace tout au long de la Seconde Guerre mondiale, et le fait que les variantes finales de ce magnifique avion aient été bien plus performantes que celles qui ont fait leur première apparition sur la base RAF Duxford au cours de l'été 1938.

Le Spitfire a fait l'objet d'un développement presque constant lui permettant de rester à la pointe de la technologie des chasseurs. Mais ce travail essentiel a été interrompu par l'introduction du nouveau Focke Wulf FW190 de la Luftwaffe en 1941, un avion redoutable supérieur au Spitfire Mk.V qui était largement en service à l'époque. Une nouvelle variante du Spitfire, le Mk.VIII, se trouvait alors à un stade de développement avancé, mais la production effective était encore loin, car les gabarits de fabrication n'avaient pas encore été installés dans les usines à l'époque. L'introduction de la version hybride Mk.IX, un avion qui a heureusement été une révélation et s'est montré plus qu'à la hauteur du Focke Wulf, s'est avérée une excellente solution transitoire.

Le Spitfire Mk.VIII, dont la production s'est poursuivie, était essentiellement un chasseur conçu dès le départ pour être la prochaine version du chasseur et une

variante de production majeure. Propulsé par les dernières versions du moteur Merlin, le Mk.VIII présentait un fuselage renforcé, une roulette de queue rétractable et une gouverne de direction plus large, avec des versions optimisées pour les opérations à haute, moyenne et basse altitude.

Cette variante du Spitfire a servi principalement avec des unités basées à l'étranger, avec la RAF en Méditerranée, au Moyen-Orient et en Extrême-Orient, et avec la RAAF dans le Pacifique Sud-Ouest. De nombreux pilotes ayant volé sur plusieurs versions de ce célèbre chasseur considéraient le Mk.VIII comme le meilleur Spitfire de tous.

Spécification:

Vitesse maximale: 650 km/h à 6 400 m

Rayon d'action : 660 km

Envergure: 11,23 m

Longueur: 9.65 m

Armement: 2 canons Hispano de 20 mm 4 mitrailleuses Browning de 7,7 mm

Airfix would like to thank the teams at the Aircraft Restoration Company and Biggin Hill Heritage Hangar for their help in the development of this model.

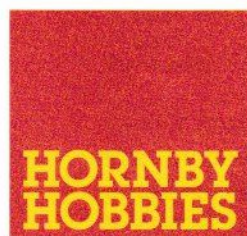

FOR BEST RESULTS:

Surfaces to be painted should be clean – before parts are removed from the sprue, wash in warm, soapy water, rinse and dry thoroughly. Stir paints thoroughly before use.

PLEASE NOTE:

Some parts in the kit may not be required to build the model specified.



Manufactured by: Hornby Hobbies Ltd Westwood, Margate, Kent, CT9 4JX, UK +44(0)1843 233525 customerservices.uk@hornby.com

EU Authorised Representative: Hornby Italia SRL Viale dei Caduti, 52/A6, Castel Mella (BS), Italy, 25030 +39 0687501292 customerservices.it@hornby.com

DE Die Spitfire wird von vielen als das berühmteste Kampfflugzeug in der Geschichte der Luftfahrt angesehen. Es ist wirklich erstaunlich, dass dieses erstmals im März 1936 startende Flugzeug weiterhin Millionen Menschen auf der ganzen Welt bekannt ist. Dabei ist wohl besonders beeindruckend, wie im Lauf ihres langen Einsatzes im Zweiten Weltkrieg die grundlegende Konstruktion der Spitfire nachgerüstet und so effektiv optimiert werden konnte. Die Leistungsfähigkeit der zuletzt gebauten Varianten übertrafen die der im Sommer 1938 von der RAF in Duxford in Dienst gestellten Maschinen ganz bedeutend.

Während die Spitfire nahezu fortlaufend auf den damals höchsten technischen Stand bei Kampfflugzeugen weiterentwickelt wurde, wurden die entscheidenden Arbeiten daran 1941 mit der Übernahme der gefürchteten Focke Wulf Fw190 durch die Luftwaffe unterbrochen. Diese war nämlich der zu diesem Zeitpunkt weit verbreitet eingesetzten Spitfire Mk.V der RAF überlegen. Eine neue Variante der Spitfire war zwar als Mk.VIII bereits auf einer hohen Entwicklungsstufe, doch ließ ihre Produktion noch auf sich warten, da die Fertigungseinrichtungen in den Herstellungsbetrieben noch nicht montiert waren. Als Übergangslösung wurde die Mk.IX eingeführt, die sich als Überraschungserfolg erwies und der Focke Wulf mehr als bloß Paroli bieten konnte.

Die geplante Spitfire Mk.VIII ging schließlich in Produktion. Sie war im Wesentlichen als Jagdflugzeug konzipiert und von Anfang an technisch als nächste und hauptsächliche Bauvariante ausgelegt. Die

ES Aunque el Spitfire está considerado como el avión de combate más famoso de la historia de la aviación, no deja de ser increíble pensar que un aparato que realizó su primer vuelo allá por marzo de 1936 siga siendo objeto de tanta fascinación a día de hoy y que millones de personas en todo el mundo lo sigan conociendo. Quizá la característica más impresionante asociada al legado perdurable del Spitfire sea cómo su diseño básico fue capaz de adaptarse y mejorarse de forma tan eficaz a lo largo de la Segunda Guerra Mundial y cómo las variantes finales de este magnífico avión eran mucho más capaces que las que llegaron por primera vez a RAF Duxford durante el verano de 1938.

El Spitfire fue sometido a un desarrollo casi constante para permitirle mantenerse en la vanguardia de la tecnología de cazas, pero este trabajo vital se vio interrumpido por la introducción del nuevo y temible Focke Wulf Fw190 de la Luftwaffe en 1941, un avión que superaba al Spitfire Mk.V que estaba en servicio de forma masiva en aquel momento. Una nueva variante del Spitfire, el Mk.VIII, se encontraba en una fase avanzada de desarrollo en aquel momento; sin embargo, la producción real estaba aún algo lejos, ya que las plantillas de fabricación no se habían instalado en las fábricas por aquella fecha. Una solución provisional resultó ser la introducción del híbrido Mk.IX, un avión que afortunadamente resultó ser toda una revelación y que estaba más que a la altura del Focke Wulf.

El proyectado Spitfire Mk.VIII continuaría en producción y era, en esencia, un caza intencionadamente diseñado y concebido desde el principio para ser la siguiente versión del caza y una variante de

SV Även om Spitfire är allmänt ansett som en av världens mest kända stridsflygplan i flygplanshistorien är det fortfarande fantastiskt att ett flygplan som flög för första gången i mars 1936 fortfarande fascinerar än idag och hur miljontals människor världen över fortfarande känner till den. Den kanske allra mest imponerande funktionen som förknippas med Spitfires arv är hur dess enkla utformning kunde anpassas och uppgraderas så effektivt under andra världskriget. De slutgiltiga varianterna av det här otroliga flygplanet var långt mycket bättre än de som först kom till RAF Duxford sommaren 1938.

Spitfire har genomgått i princip konstanta förändringar, allt för att se till att den ligger i framkant för stridsplansteknik. Det här viktiga arbetet avbröts när Luftwaffes skräckinjakande Focke Wulf Fw190 år 1941, som var ett flygplan som var överlägsen Spitfire Mk.V vilket användes på bred front vid den här tiden. En ny variant av Spitfire, Mk.VIII, befann sig vid ett långt framskridet utvecklingsskede vid den här tidpunkten, däremot hade inte själva produktionen kommit igång eftersom tillverkningsjiggarna ännu inte var på plats i fabriken. En temporär lösning resulterade i hybriderna Mk.IX, ett flygplan som lyckligtvis visade sig bli riktigt nyskapande och kunde göra mer än bara utmana Focke Wulf.

Den planerade Spitfire Mk.VIII togs till slut i produktion och blev ett stridsflygplan som avsiktligt utformats och konstruerats för att bli Spitfires nästa version och produceras i stor mängd. Mk.VIII

Mk.VIII var med den senaste versionerna av Merlin-motorn utrustad. Utöver detta hade den förstärkt rump, ett inziehbart Heckrad och ett förbättrat sidoruder, där speciella utföringar för insatser i hög, medel och låg höjd optimerades.

Den här varianten av Spitfire användes främst av enheter baserade i överseer, med RAF i Medelhavet, Mellan- och fjärran östern och RAAF i sydvästra Stilla-havsområdet. Många av de piloter som flög flera varianter av den legendariska Spitfire ansåg att Mk.VIII flög allra bäst.

Spezifikation:

Höchstgeschwindigkeit: 650 km/h auf 6400 m Flughöhe

Reichweite: 660 km

Spannweite: 11,23 m

Länge: 9,65 m

Bewaffnung: zwei 20 mm Hispano-Kanonen vier 7,7 mm Browning-MGs

producción importante. Dotado de las últimas variantes del motor Merlin, el Mk.VIII presentaba un fuselaje reforzado, rueda de cola retráctil y la adopción de un nuevo timón de dirección de cuerda ancha, con versiones optimizadas para operaciones a gran, media y baja altitud.

Esta variante del Spitfire sirvió principalmente en unidades basadas en ultramar, con la RAF en el Mediterráneo, Oriente Medio y Extremo Oriente, así como la RAAF en el Pacífico Sudoccidental. Muchos pilotos que volaron en varias versiones de este famoso caza consideraban al Mk.VIII como el Spitfire que mejor volaba de todos.

Especificación:

Velocidad máxima: 650 km/h a 6400 m

Autonomía: 660 km

Envergadura: 11,23 m

Longitud: 9,65 m

Armamento: 2 cañones Hispano de 20 mm 4 ametralladoras Browning de 7,7 mm

drevs av de senaste versionerna av Merlin-motorn och hade en förstärkt flygkropp, indragbart stjärthjul och ett nytt roder med bred bas, med versioner som var optimerade för operationer på hög, medelhög och låg höjd.

Den här varianten av Spitfire tjänstgjorde huvudsakligen med enheter som var stationerade utomlands, med RAF i Medelhavet, Mellan- och fjärran östern och RAAF i sydvästra Stilla-havsområdet. Många av de piloter som flög flera varianter av den legendariska Spitfire ansåg att Mk.VIII flög allra bäst.

Spezifikation:

Maximal hastighet: 650 km/h vid 6400 m

Räckvidd: 660 km

Spännvidd: 11,23 m

Längd: 9,65 m

Bestyckning: 2 x 20 mm Hispano-automatkanoner 4 x 7,7 mm Browning-kulsprutor

ASSEMBLY INSTRUCTIONS

EN Study drawings and practise assembly before cementing parts together. Carefully scrape paint from cementing surfaces. All parts are numbered. Paint small parts before assembly. To apply decals cut sheet as required, dip in warm water for a few seconds, slide off backing into position shown. Use in conjunction with box artwork. Not appropriate for children under 36 months of age, due to the presence of small detachable parts.

FR Étudier attentivement les dessins et simuler l'assemblage avant de coller les pièces. Gratter soigneusement toute peinture sur les surfaces à coller. Toutes les pièces sont numérotées. Peindre les petites pièces avant l'assemblage. Pour coller les décalcomanies, découper le motif, le plonger quelques secondes dans de l'eau chaude puis le poser à l'endroit indiqué en décollant le support papier. Utiliser conjointement avec les illustrations sur la boîte. Ne convient pas aux enfants de moins de 36 mois - présence de petits éléments détachables.

DE Vor dem Zusammenkleben der Teile die Zeichnungen sorgfältig ansehen und die zu verklebenden Teile zur Vermeidung möglicher Fehler versuchsweise zusammenfügen. Dann an den Klebeflächen vorhandene Farbbeschichtung vor dem Zusammenkleben vorsichtig abkratzen. Alle Bestandteile sind mit Nummern versehen. Kleine Teile vor dem Zusammenbau bemalen. Abziehbilder wie gewünscht ausschneiden. Vor dem Anbringen einige Sekunden in warmes Wasser tauchen und dann vom Trägerpapier in ihre vorgesehene Position schieben. Dabei die Abbildungen auf der Schachtel beachten. Nicht für Kinder unter 36 Monaten geeignet, da abnehmbare bzw. lose angebrachte Kleinteile enthalten sind.

ES Estudiar los dibujos y practicar el montaje antes de pegar las piezas. Raspar cuidadosamente la pintura en las superficies de contacto antes de pegar las piezas. Todas las piezas están numeradas. Es conveniente pintar las piezas pequeñas antes de su montaje. Para aplicar las calcomanías, cortarlas de la hoja, sumergirlas en agua tibia durante unos segundos y deslizarlas a la posición indicada. Utilizar en conjunción con la ilustración de la caja. No es adecuado para niños menores de 36 meses, ya que contiene piezas pequeñas que podrían soltarse.

SV Studera bilderna noggrant och sätt ihop delarna innan du limmar ihop dem. Skrapa försiktigt bort färg från limmade delar. Alla delarna är numrerade. Måla smådelarna före ihopsättning. Sätt fast dekalerna genom att klippa arket, doppa i varmt vatten några sekunder och låta baksidan glida på plats som bilden visar. Använd enligt bildanvisningarna på kartongen. Rekommenderas ej för barn under 3 år. Innehåller löstagbara smådelar.

NL Tekeningen bestuderen en delen in elkaar zetten alvorens deze te lijmen. Lak voorzichtig van lijmlakken afschrapen. Alle delen zijn genummerd. Kleine delen vóór montage verven. Voor aanbrengen van stickers, gewenste stickers uit het vel knippen, een paar seconden in warm water dompelen en dan van het schutblad af op afgebeelde plaats schuiven. Hierbij afbeelding op doos raadplegen. Niet geschikt voor kinderen onder 3 jaar, omdat kleine deeltjes gemakkelijk kunnen losraken.

PO Przed przystąpieniem do sklejania przestuduj uważnie rysunki i przeczytaj składanie części. Ostrożnie zeskrub ze sklejalnych powierzchni farbę. Wszystkie części są ponumerowane. Drobne części pomaluj przed ich złożeniem. Celem przeniesienia kalkomanii wycnij ją z arkusza, zanurz na kilka sekund w letniej wodzie i zsuń z podłoża na wymaganie miejsce. Używaj w połączeniu ze wzorami na pudełku. W związku z obecnością wielu drobnych, rozbiieralnych części, nieodpowiednie dla dzieci poniżej 3 lat.

IT Studiare i disegni ed esercitarsi a montare i vari pezzi prima di fissarli con la colla. Raschiare con cura le tracce di vernice dalle superfici da incollare. Tutti i pezzi sono numerati. Verniciare i pezzi di piccole dimensioni prima di montarli. Per applicare le decalcomanie, ritagliare il foglio nel modo richiesto, immergere in acqua calda per alcuni secondi, quindi staccare la decalcomania dalla carta di supporto e posizionarla nel punto desiderato. Usare le decalcomanie come indicato nell'illustrazione riportata sulla confezione. Non adatto a bambini di età inferiore a 36 mesi per la presenza di componenti di piccole dimensioni che potrebbero staccarsi.

PT Estudiar atentamente os desenhos e experimentar a montagem. Raspar cuidadosamente as superfícies de modo a eliminar pintura antes de colar. Todas as peças estão numeradas. Pintar as pequenas peças antes de colar. Para aplicar as decalcomanias, cortar as folhas e mergulhar em água morna por alguns segundos, depois deslizar e aplicar no respectivo lugar, como indicado nas ilustrações na caixa. Não convém a uma criança de menos de 36 meses devido à presença de pequenos elementos destacáveis.

EL Μελετήστε προσεκτικά τα σχέδια και συναρμολογήστε για πρώτη φορά τα κομμάτια χωρίς να τα συγκολλήσετε. Αφαιρέστε επιμελώς την πλαστική βαφή από τις επιφάνειες τις οποίες θα συγκολλήσετε. Όλα τα κομμάτια είναι αριθμημένα. Χρωματίστε τα μικρά κομμάτια πριν από τη συναρμολόγηση. Για να κολλήσετε τις χαλκομανίες, κόψετε γύρω από το σχέδιο όπως απαιτείται, βυθίστε το μερικά δευτερόλεπτα σε χλιαρό νερό και μετά τοποθετήστε το στη θέση που υποδεικνύεται, αφαιρώντας τη μεμβράνη που το καλύπτει. Λάβετε υπόψη σας ταυτόχρονα την εικονογράφηση του κουτιού. Ακατάλληλο για παιδιά ηλικίας κάτω των 36 μηνών λόγω ύπαρξης μικρών κομματιών που αποσπώνται.

FI Tutustu piirroksiin ja harjoittele kokoamista, ennen kuin liimaat osat yhteen. Raaputa maali varovasti pois liimattavilta pinoilta. Kaikki osat on numeroitu. Maalaa pienet osat ennen kokoamista. Siirtokuvien kiinnittämiseksi leikkaa ne arkista tarpeen mukaan. Kasta kuva lämpimään veteen muutaman sekunnin ajaksi, anna takapuolen liueta kovalle osoitettuun kohtaan. Käytetään yhdessä laatikon kuvituksen kanssa. Ei suositella alle kolmivuotiaille lapsille. Paljon irrotettavaa pikkuosia.

DA Studér tegningerne nøje og forsøg at sætte delene sammen, inden de klæbes sammen. Skrab forsigtigt malingen af de overflader, der skal klæbes sammen. Alle dele er nummererede. Små dele skal males, før de monteres. Overføringsbillederne påføres ved at klippe dem ud af arket, som påkrævet, dyppe dem i varmt vand i nogle få sekunder, hvorefter underlaget glides af i de viste positioner. Påføres ifølge illustrationerne på æsken. Ikke egnet til børn under 3 år på grund af tilstedeværelse af små aftagelige dele.

ASSEMBLY ICON INSTRUCTIONS

<p>Assembly phase Phase de montage Montagephase Fase de montaje Monteringsfasen Fase di montaggio Montagefase Fase de montagem Monteringsfase Kokoomisvaihe Faza składowania Φάση συναρμολόγησης</p>	<p>Cement Coller Kleben Pegar Limma Incollare Lijmen Colar Klebes Limaa Klei é Συγκολλήστε</p>	<p>Do not cement together No pas coller Nicht kleben No pegar Limma inte Non incollare Niet lijmen Não colar Skal ikke klæbes Älä liimaa Nie klei é Μη συγκολλήσετε</p>	<p>Indicates final location Indique l'emplacement final Zeigt Endposition Indica la ubicación definitiva Anger slutmønteringsplats Geeft uiteindelijke locatie aan ? Indica localización final Viser endelig placering Osoittia lopullisen sijainnin Oznacza miejsce docelowe Υποδεικνύει τελική τοποθεσία</p>	<p>Alternative part(s) provided Autre(s) pièce(s) fournie(s) Ersatzteil(e) mitgeliefert Se incluye(n) pieza(s) alternativa(s) Alternativ(a) del(ar) ingår ? Uno o più componenti alternativi forniti Alternatieve onderdelen meegeleverd Peça(s) alternativa(s) fornecida(s) Alternativ(e) del(e) medfølger Vaihtoehtoiset osat pakkauskassessa Dost epne części zamiennie Παρέχονται εναλλακτικά κομμάτια</p>	<p>Repeat this operation Répéter l'opération Vorgang wiederholen Repètir la operación Upprepa åtgärden ? De verrichting herhalen Repètir a operação Manøveren gentages Toista toimenpidet Powtórzć operację Επανάλαβετε τη διαδικασία</p>	
<p>Decals Décalcomanies Abziehbild Calcomanias Dekaler 1 Decalcomanie Stickers Decalcomania Billedoverføring Siirtokuvat Kalkomanie Χαλκομανίες</p>	<p>Crystal part Pièce cristal Kristallteil Pieza de cristal Kristalldel A1 Pezzo cristallo Kristallen onderdeel Peça de cristal Kryсталстыkke Kristalliosa Część kryształowa Κομμάτι κρυστάλλου</p>	<p>Weight Lester Beschweren Lastrar Belasta A1 Applicare un peso Verzwaren Lastrar Påfør vægt Aseta vastapaino Obciążyc balastem Επιθέστε βάρος</p>	<p>Remove by filing Enlever avec une lime Abfeilen Eliminar con lima Ta bort genom att fila Rinnuovere con la lima Verwijderen door afvijlen Remove limando Fjern ved at file væk Poista villaamalla Usun aç przy użyciu pilnika Αφαιρέστεε λιμάροντας με λίμα</p>	<p>Drill or pierce Percer Durchbohren Perforar Borra Trapanare o forare Boren of doorboren Furar Gennembor Poraa tai puhkaise Wywierćć lub przedziurawić Truthtjste</p>	<p>Cut Découper Schneiden Cortar Skär Tagliare Snijden Cortar Skeer Leikkaa Przeciąćć Kόψτε</p>	<p>Humbrol paint number No peinture Humbrol Humbrol-Farbnnummer No de pintura Humbrol Humbrol färg nummer No vernice Humbrol Humbrol verfnnummer No de pintura Humbrol Humbrol-maalin numero Nr farby Humbrol Νόμερο χρώματος Humbrol</p>



Colour chart showing all of the paint colours specified for this model. Paint reference numbers are for Humbrol products. **Note:** not all of the colours are required for all of the decal schemes. See decal scheme layouts for individual scheme colours.

Position of cockpit decals

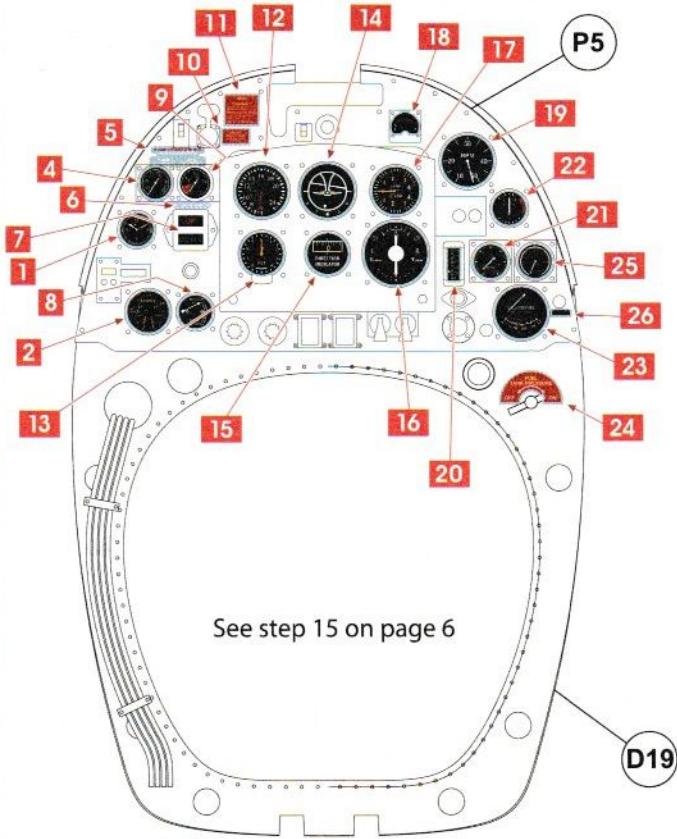

See step 14 on page 6

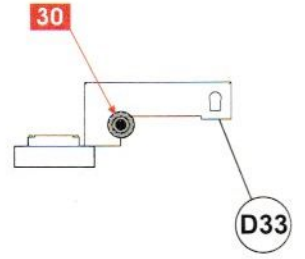

See step 30 on page 8

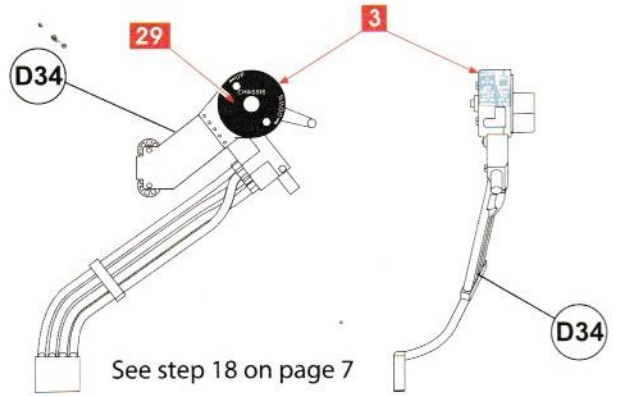

See step 18 on page 7

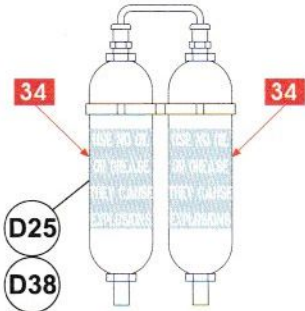

See step 28 on page 8

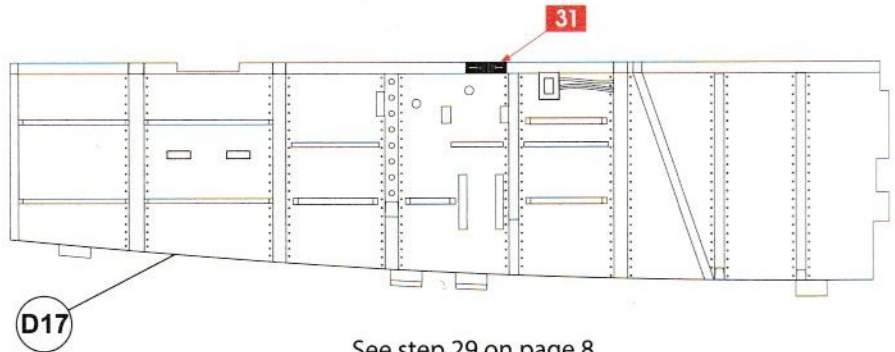

See step 29 on page 8

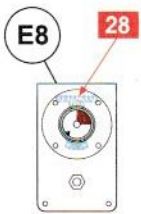

See step 35 on page 9

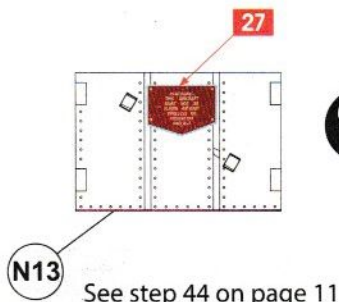

See step 44 on page 11

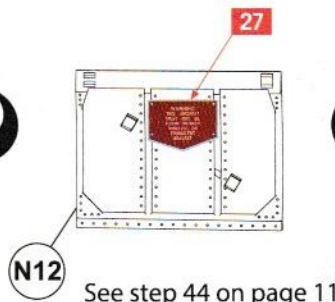

See step 44 on page 11

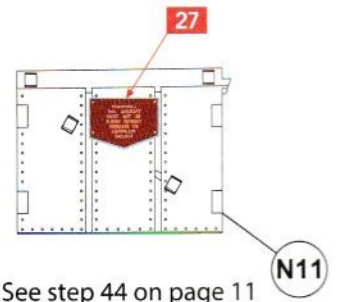

See step 44 on page 11

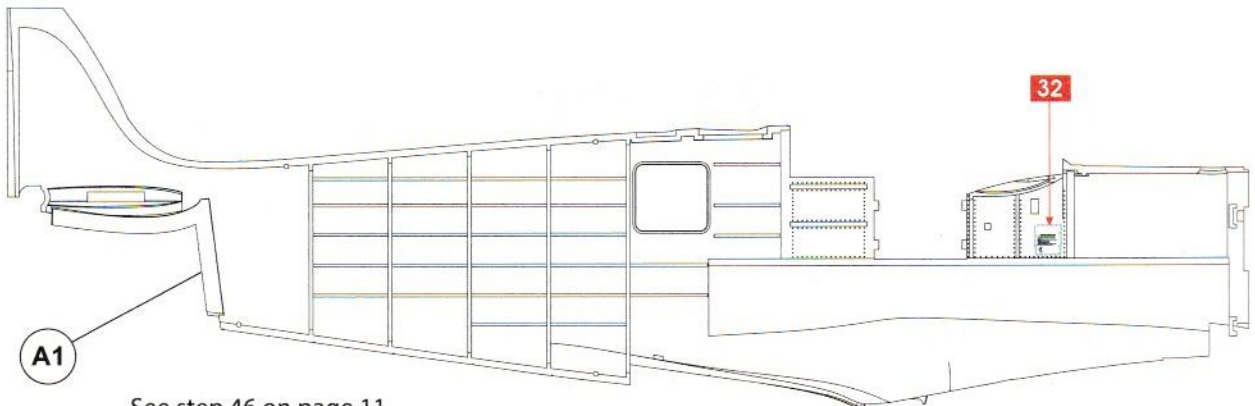

See step 46 on page 11

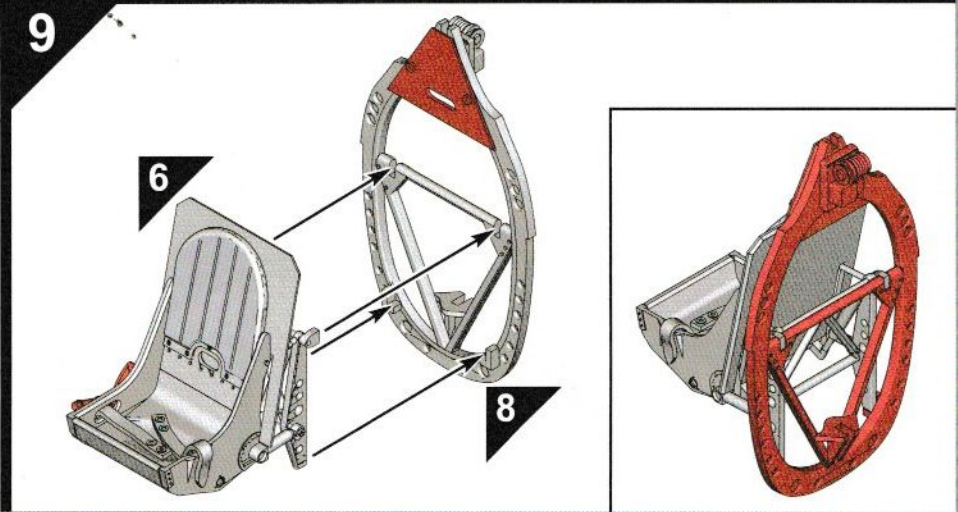
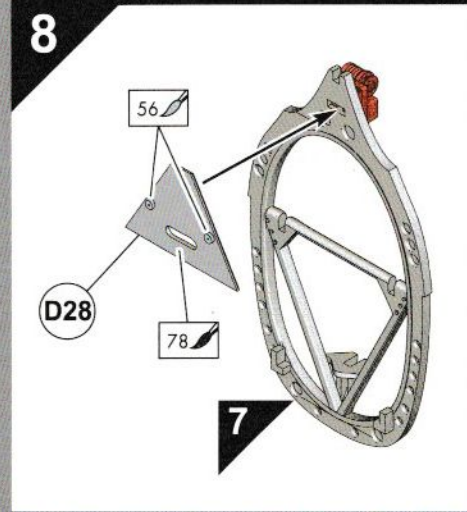
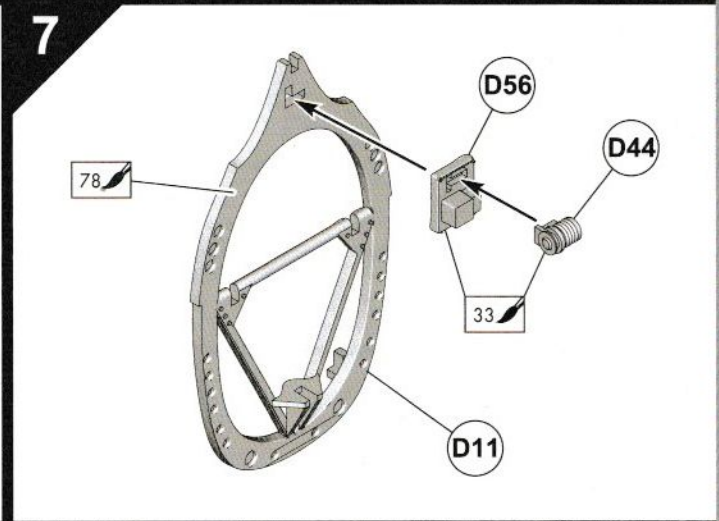
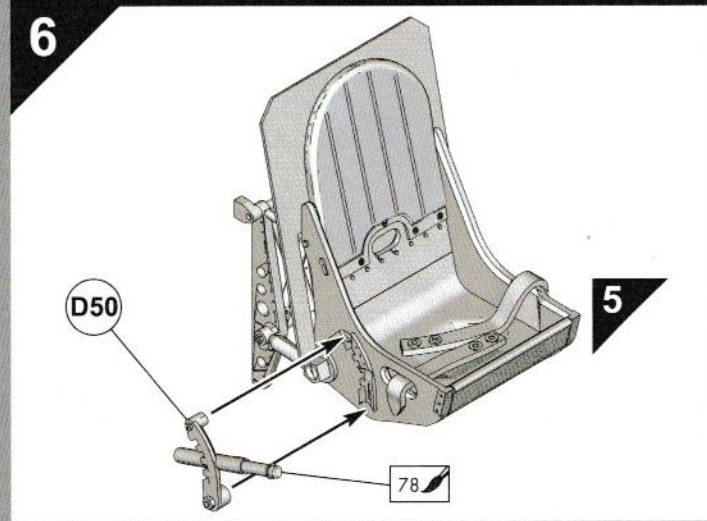
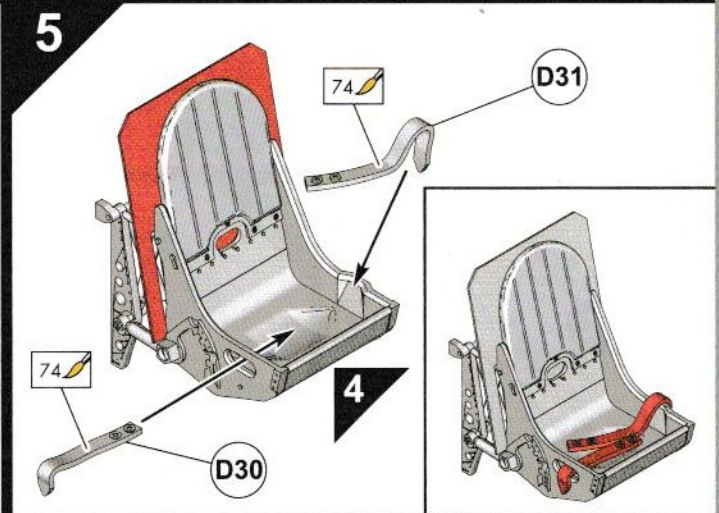
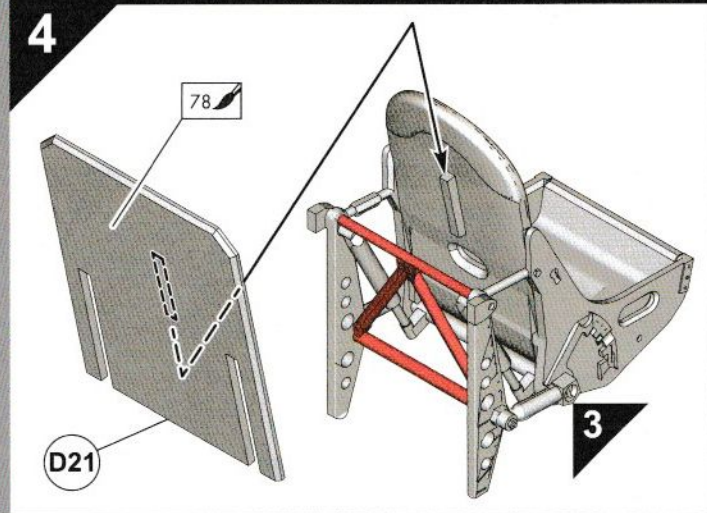
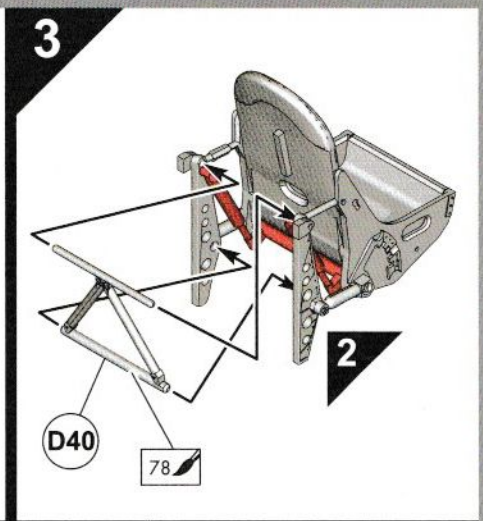
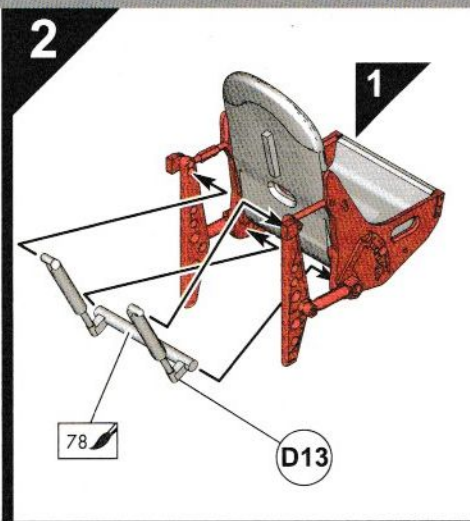
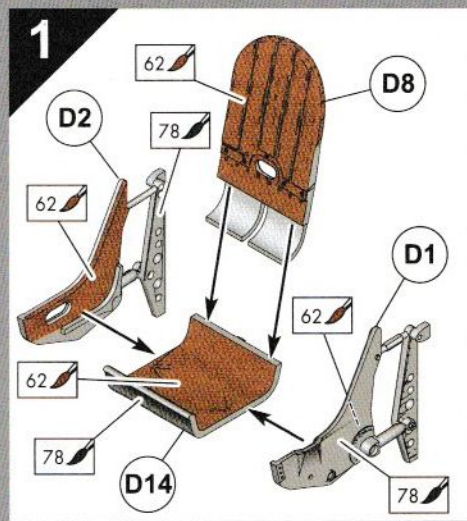

10

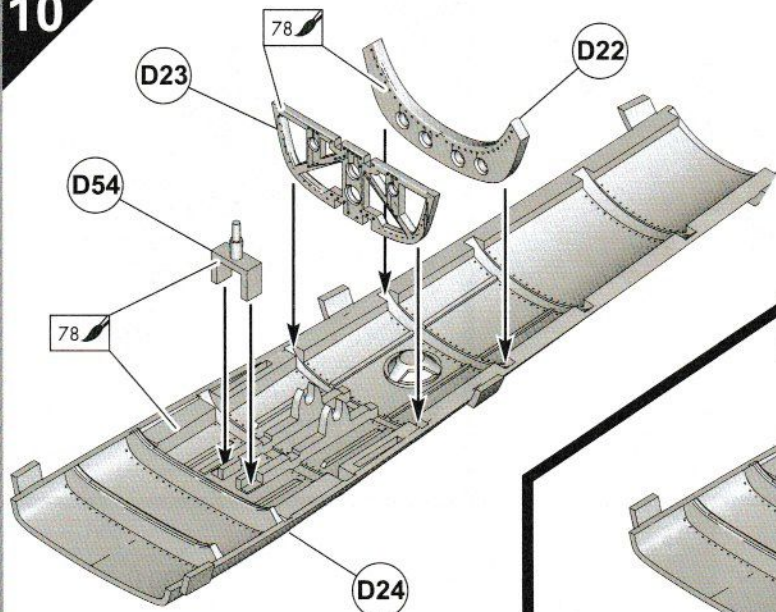

11

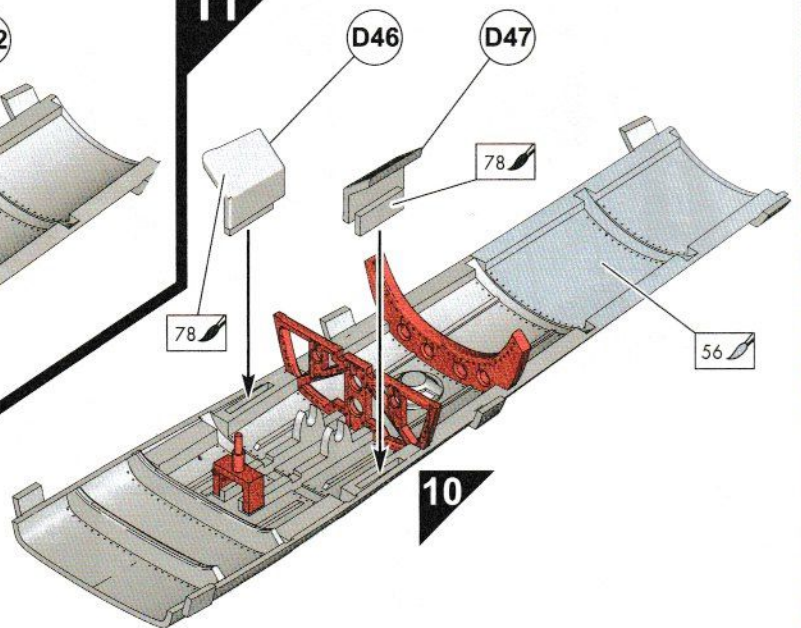

12

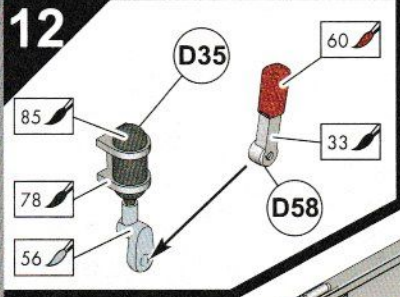

13

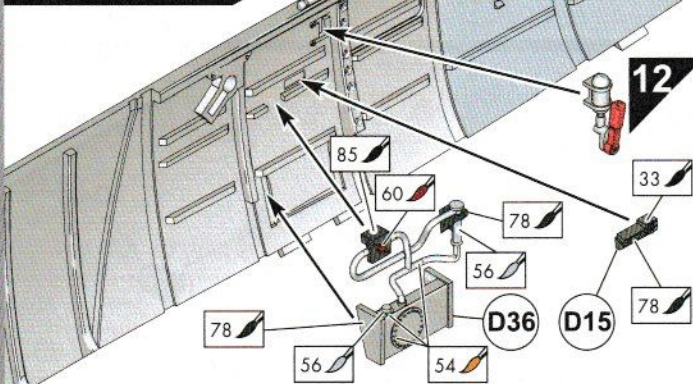
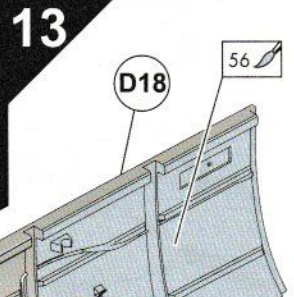

14

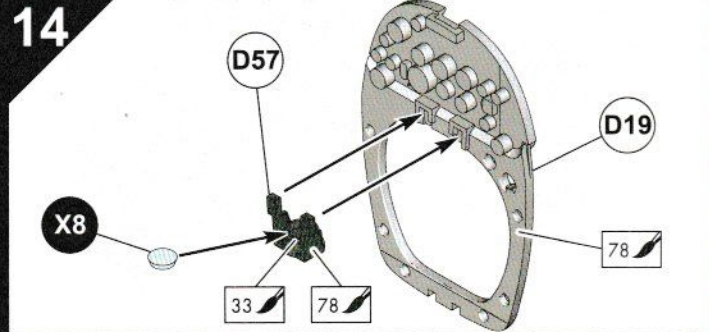

15

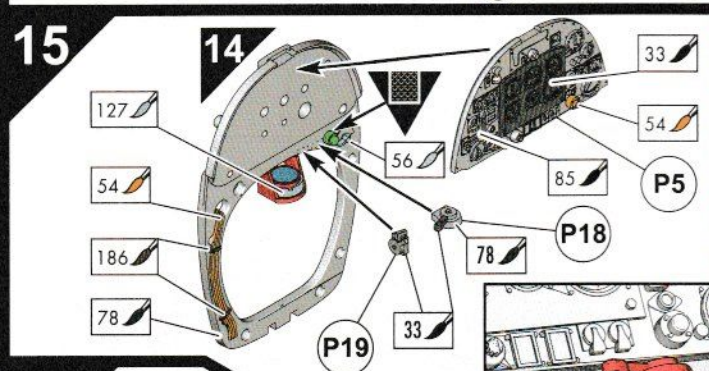

16

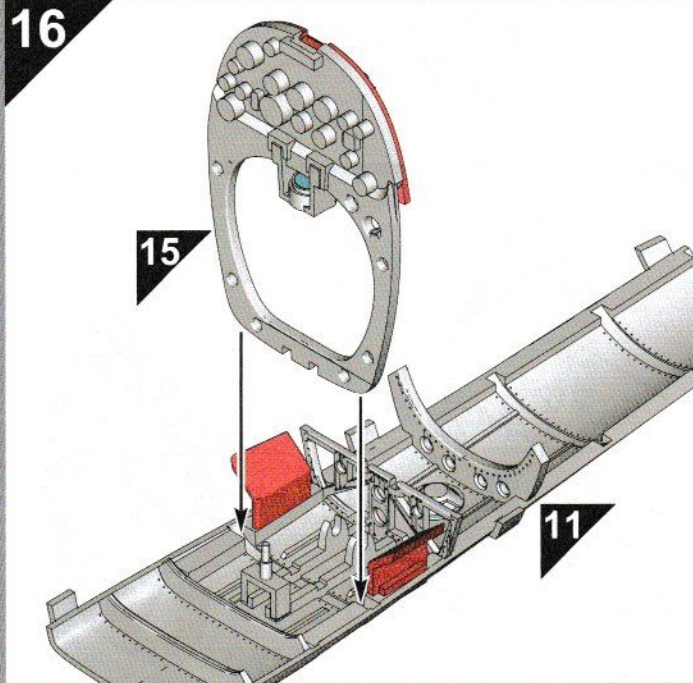

17

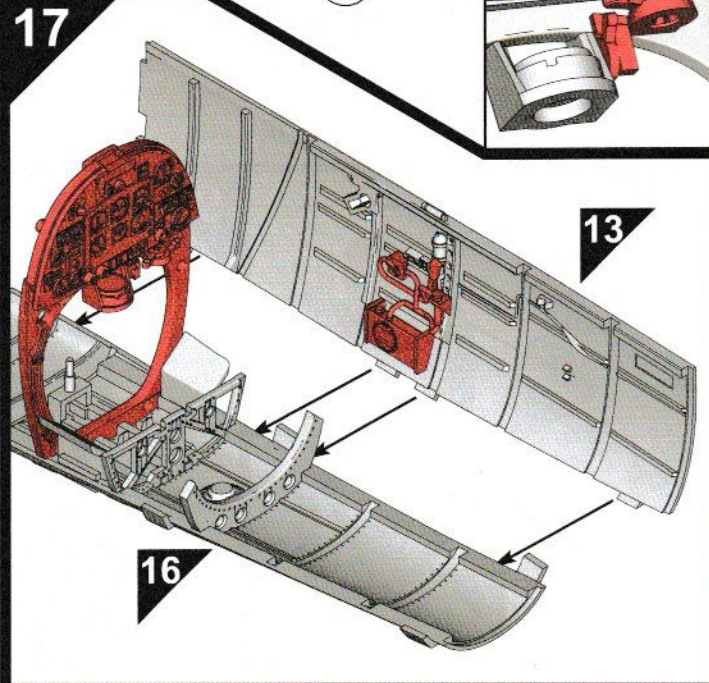

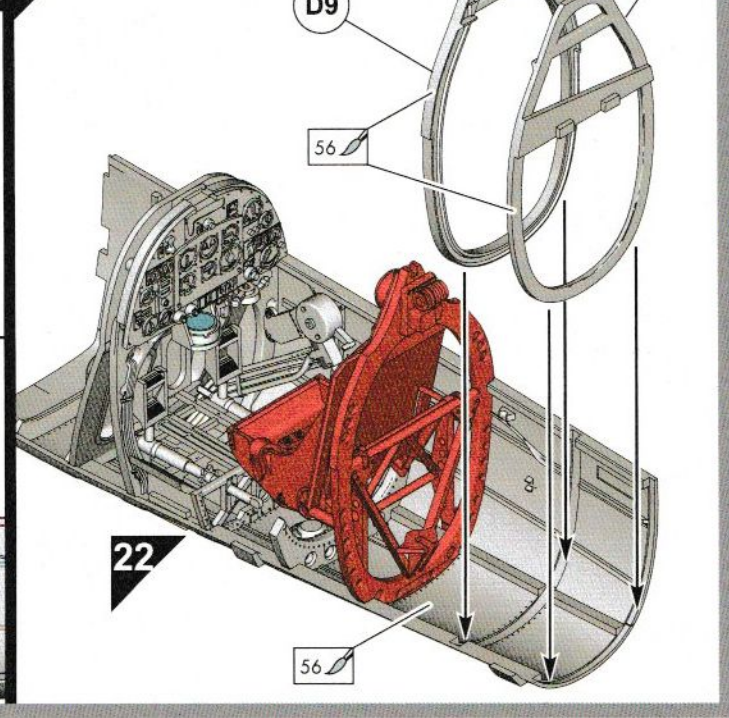
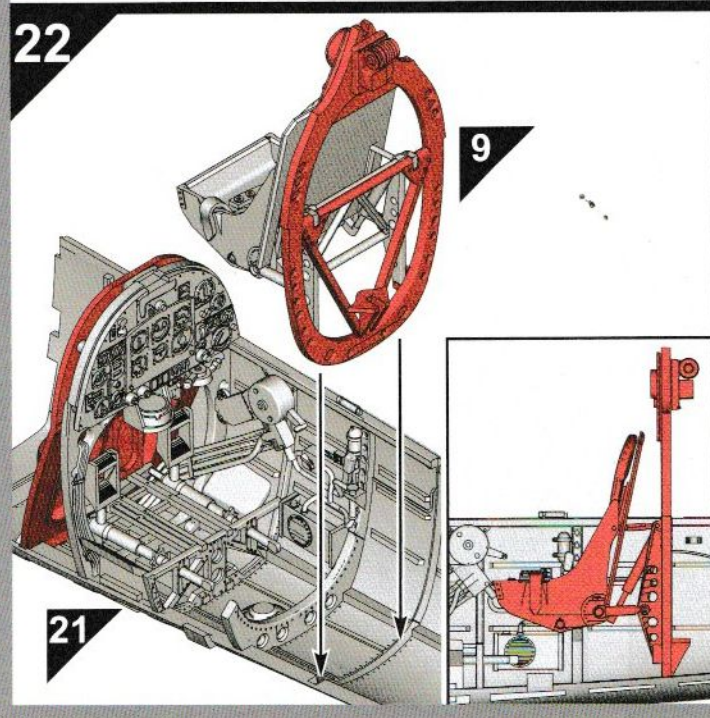
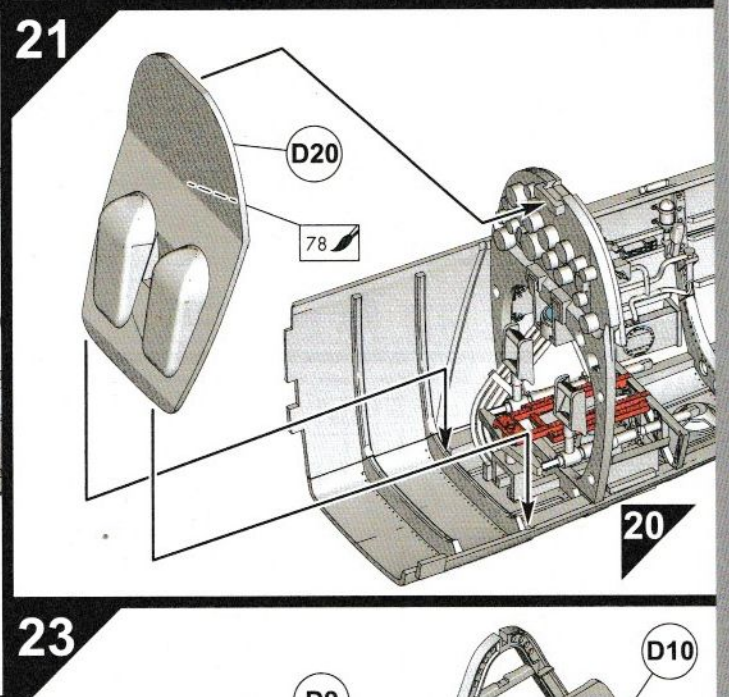
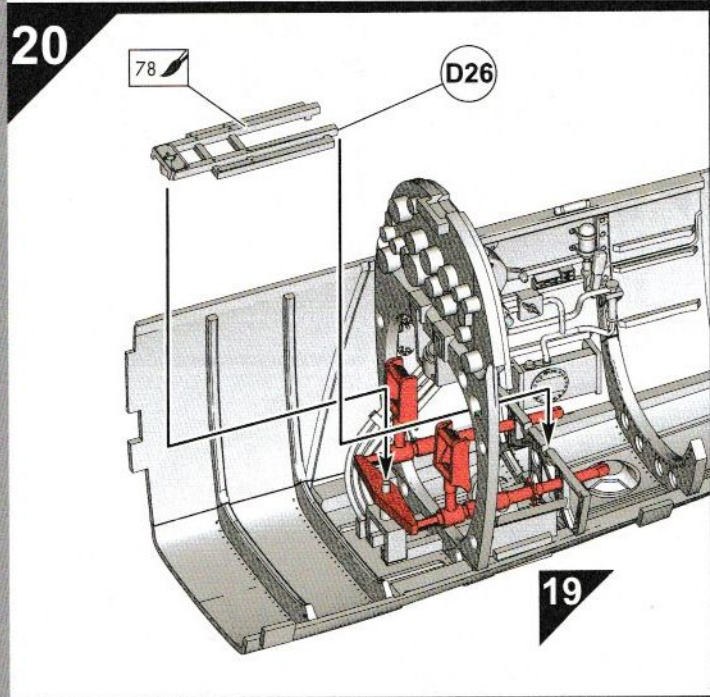
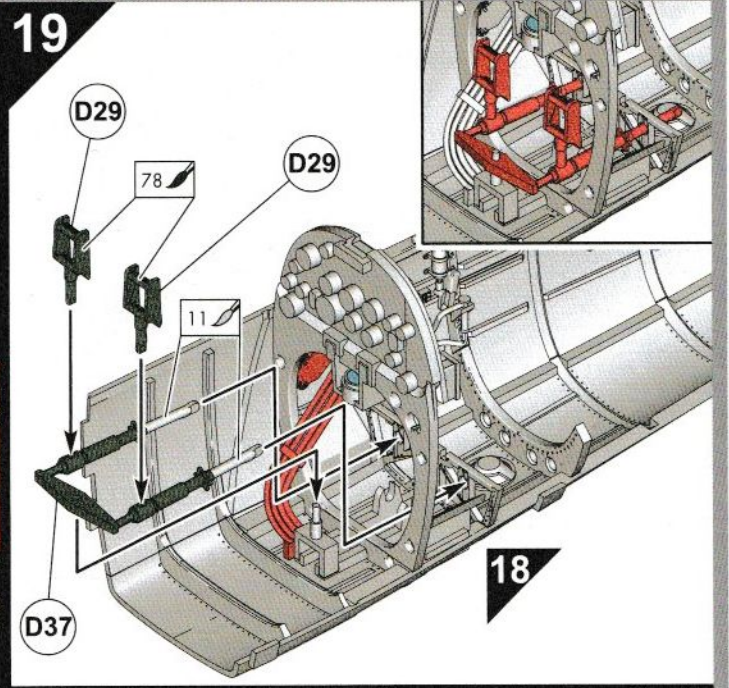
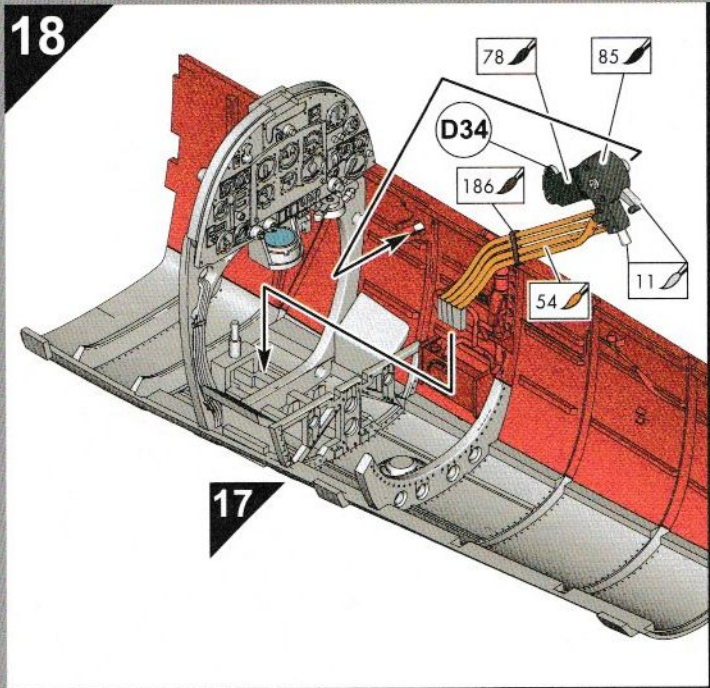

24

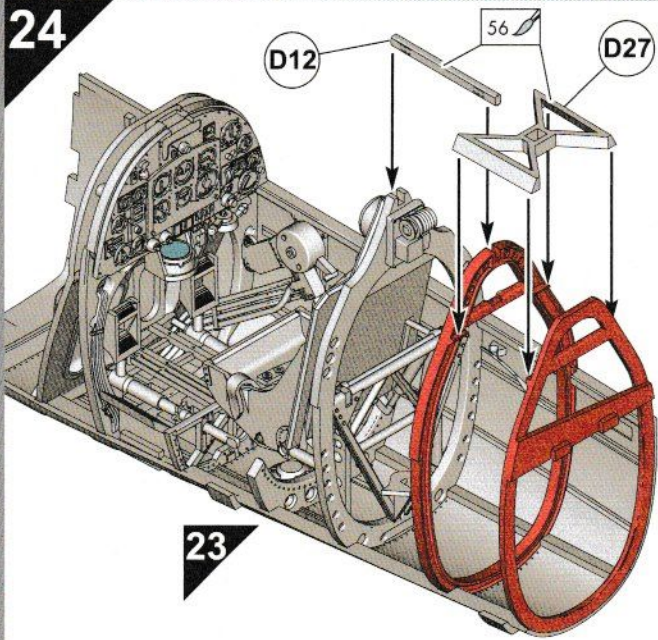

25

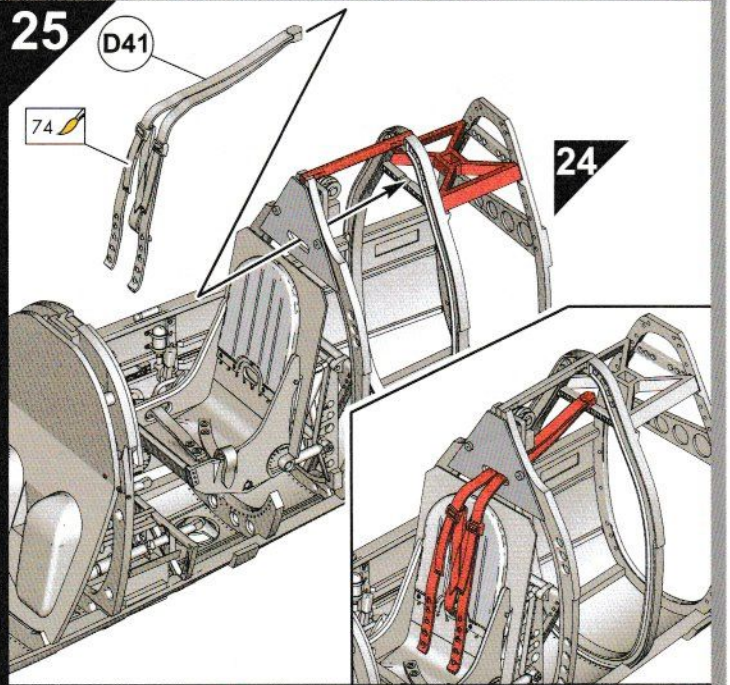

26

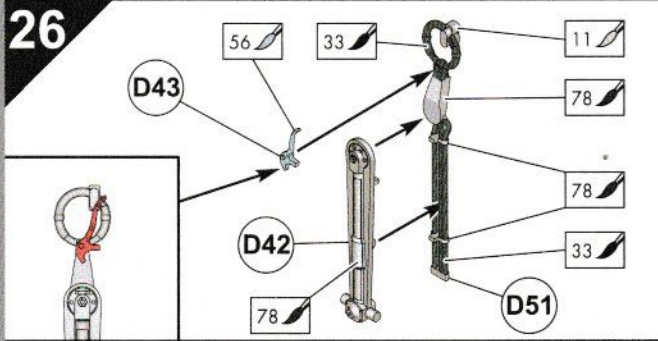

27

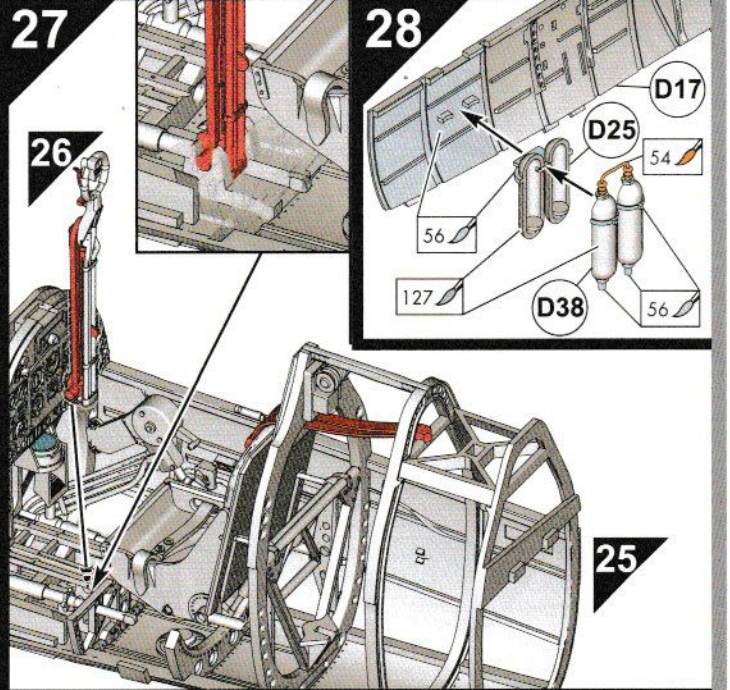

28

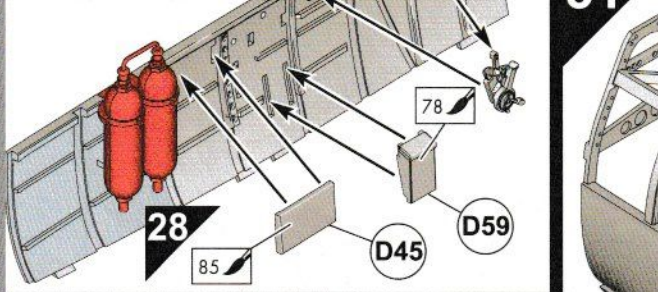
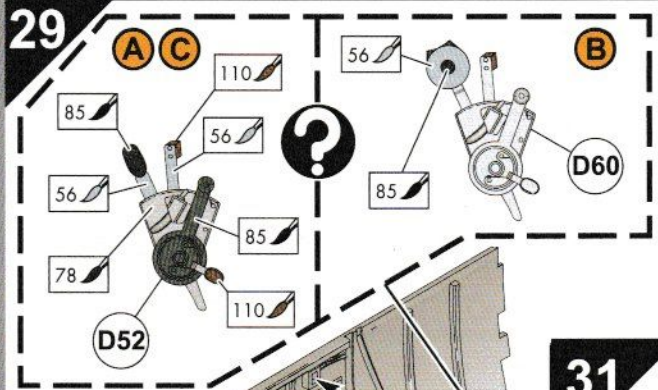

31

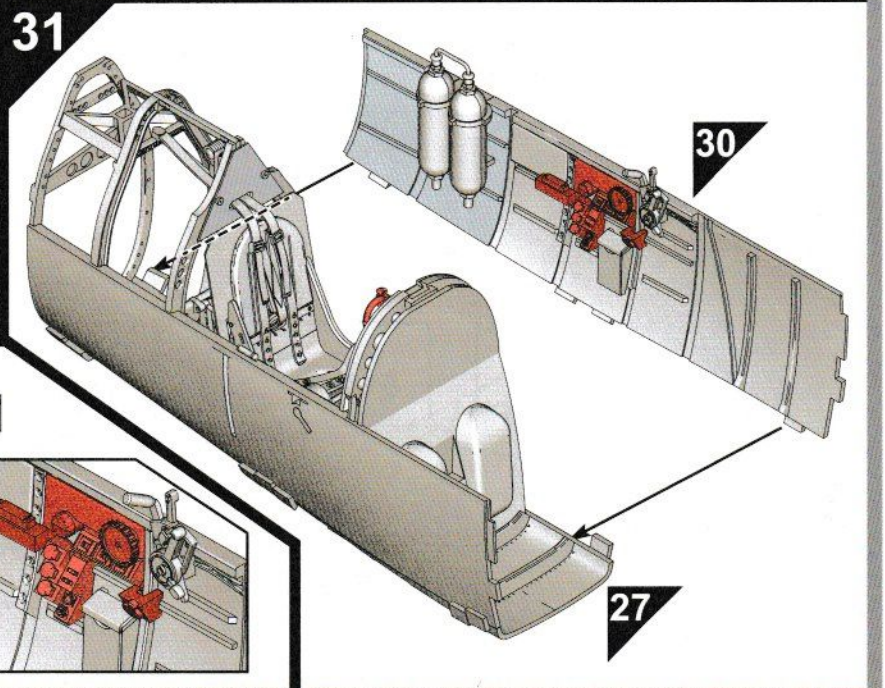

30

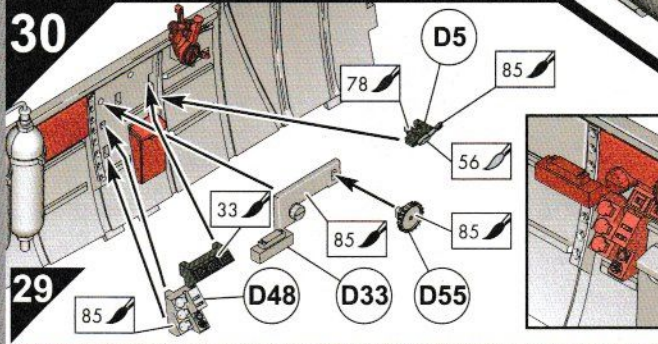

32

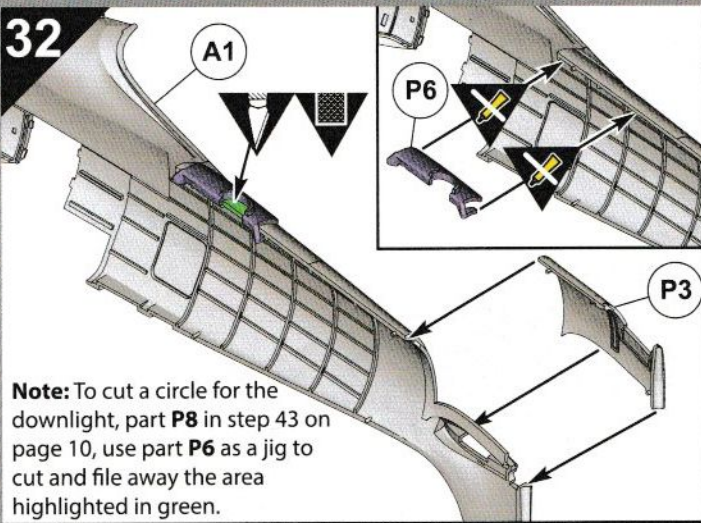

Note: To cut a circle for the downlight, part **P8** in step 43 on page 10, use part **P6** as a jig to cut and file away the area highlighted in green.

33

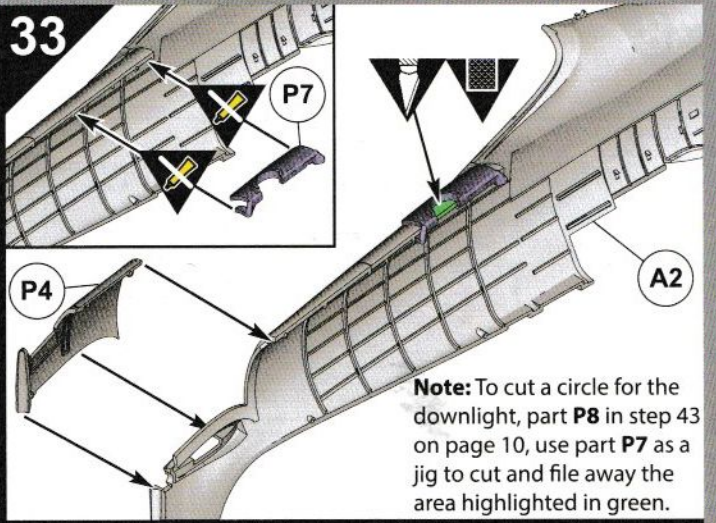

Note: To cut a circle for the downlight, part **P8** in step 43 on page 10, use part **P7** as a jig to cut and file away the area highlighted in green.

34

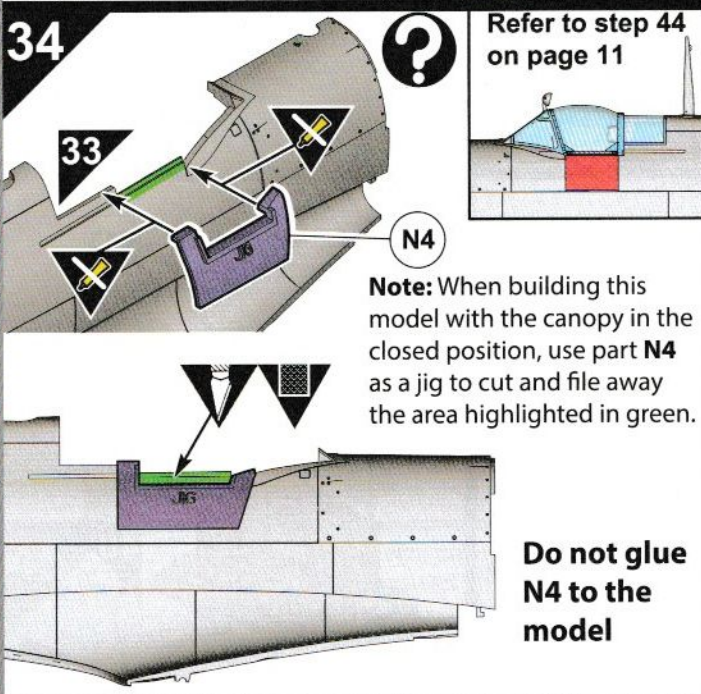

Refer to step 44 on page 11

Note: When building this model with the canopy in the closed position, use part **N4** as a jig to cut and file away the area highlighted in green.

Do not glue N4 to the model

35

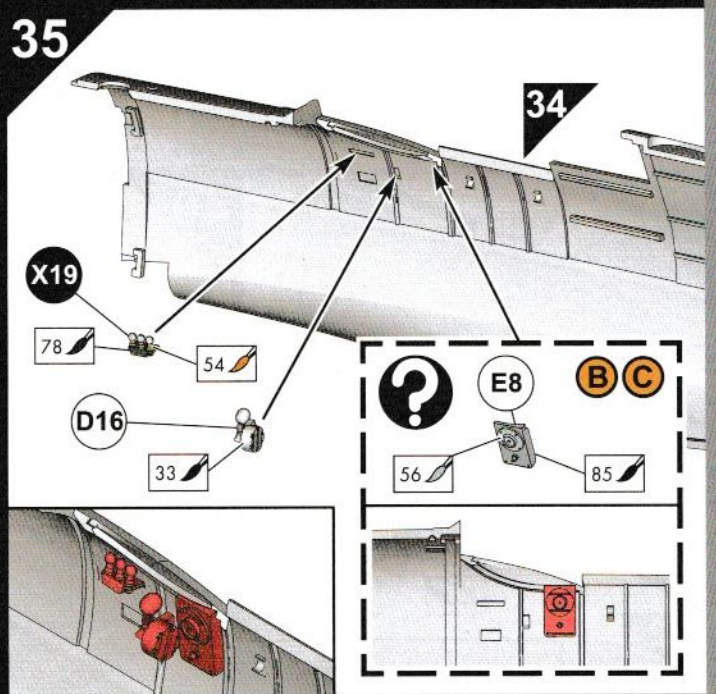

36

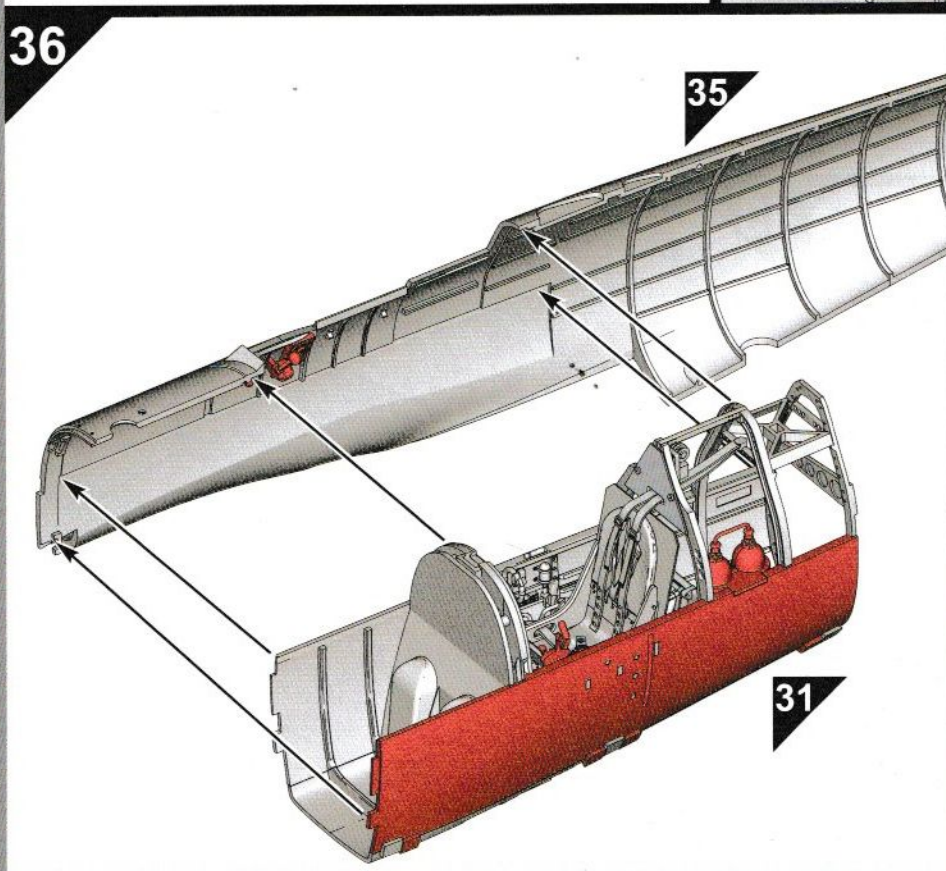

37

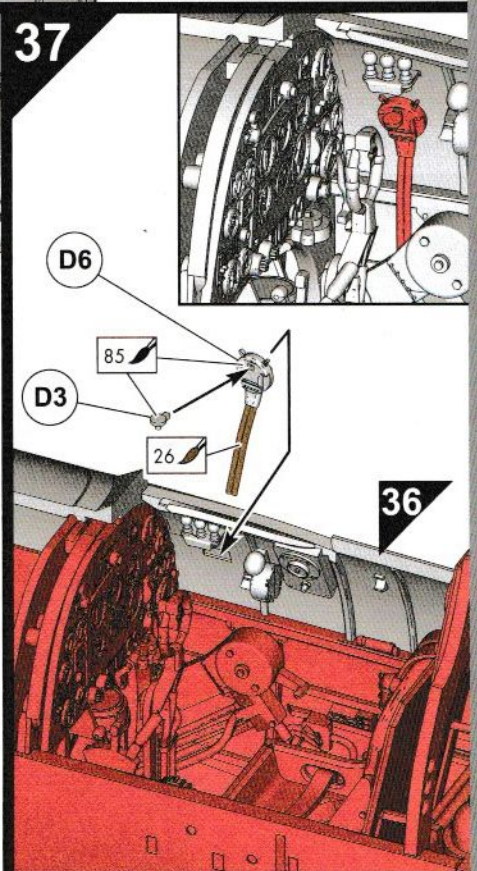

38

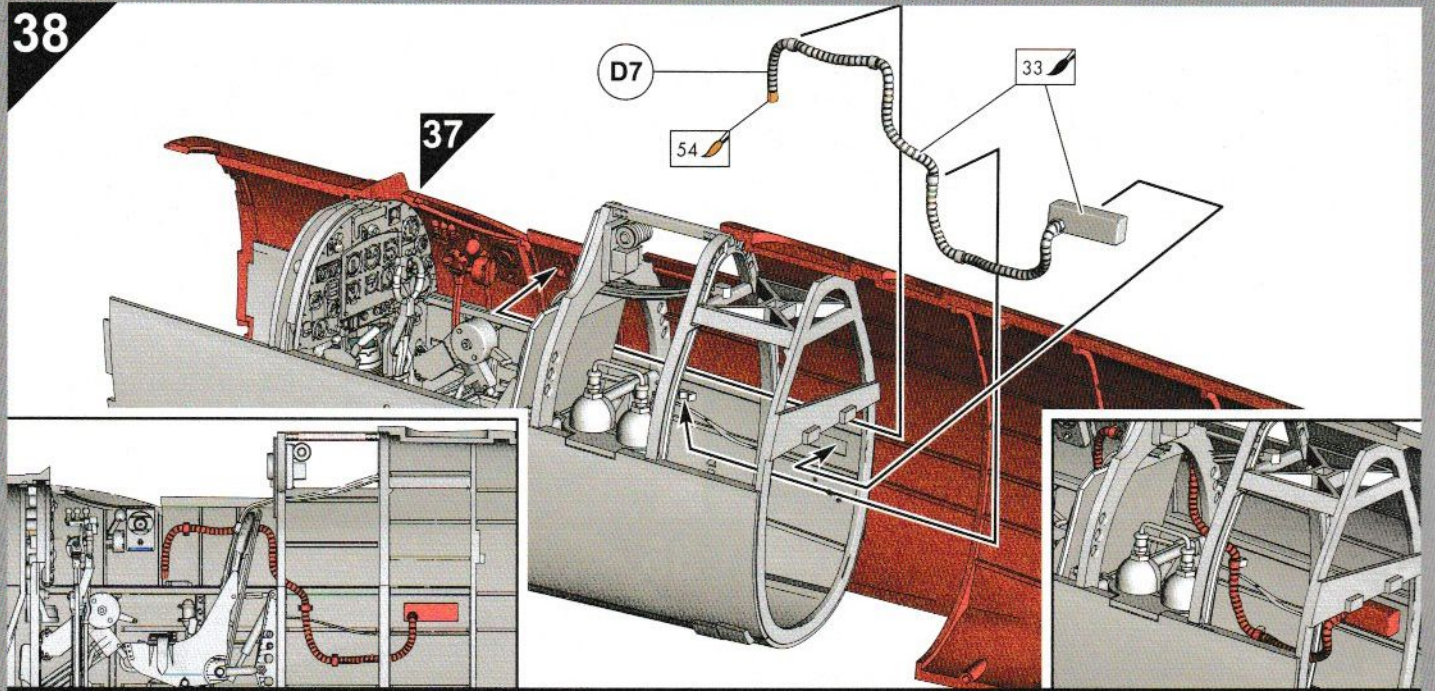

39

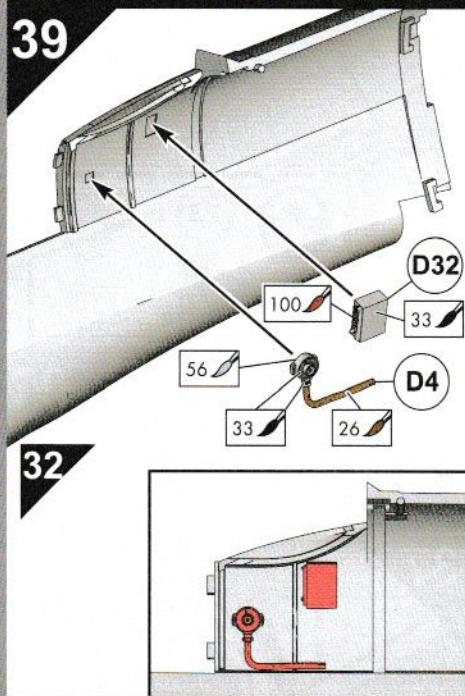

40

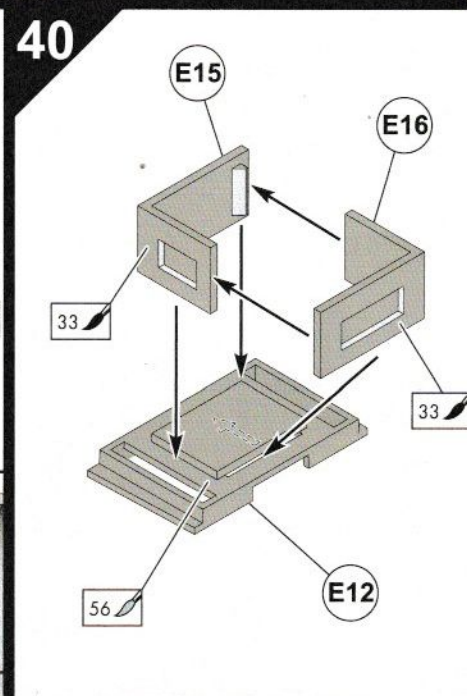

41

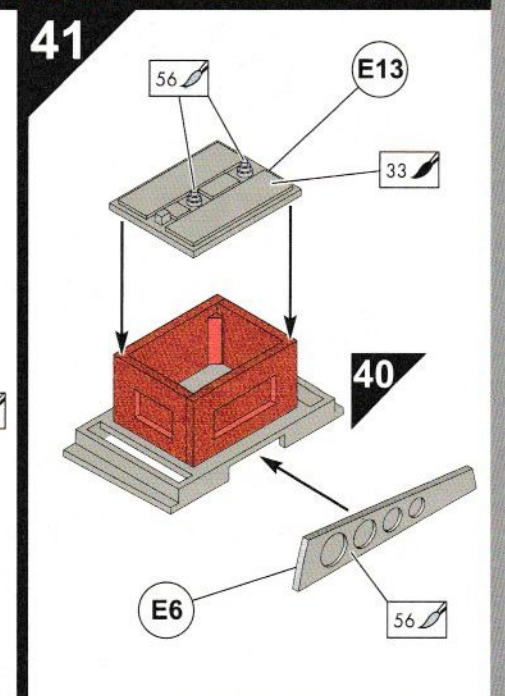

42

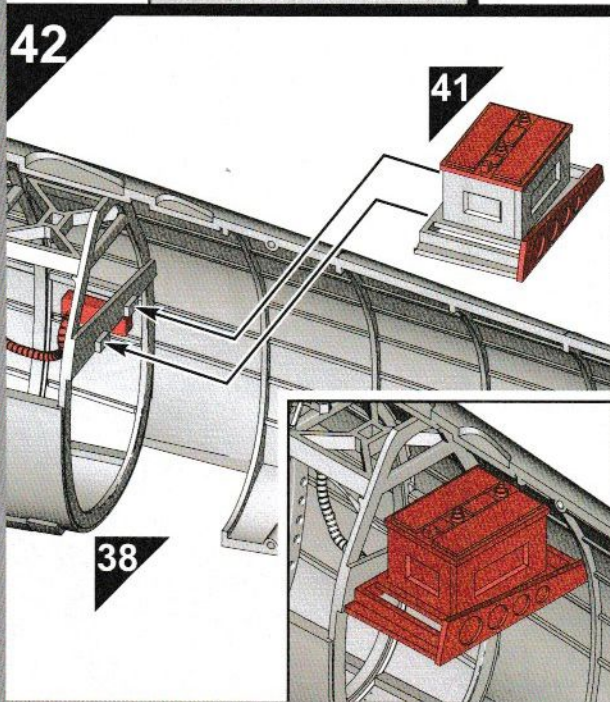

43

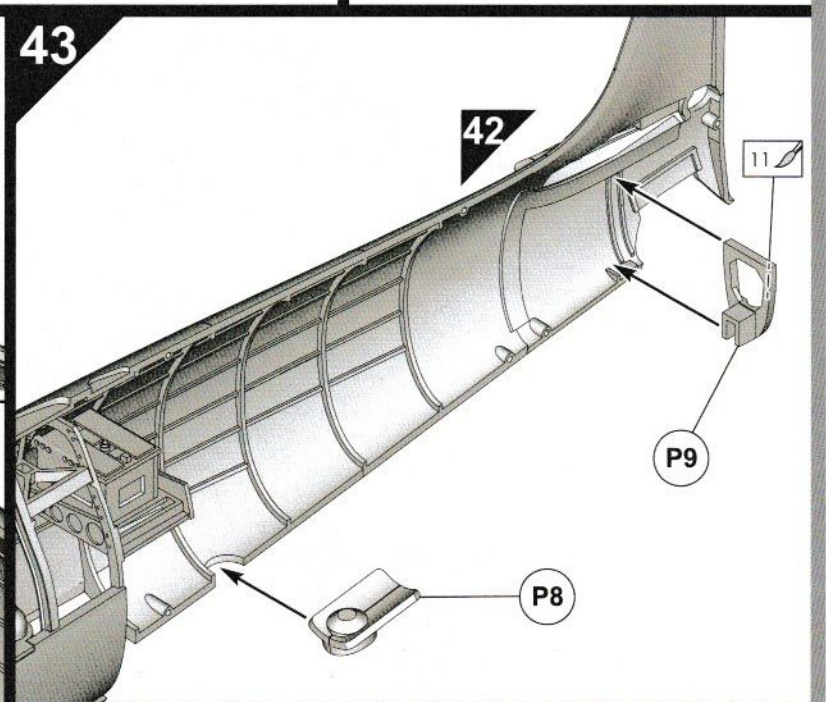

44



Note: There are 3 build options for the door shown in this step. When building this model with the door in the open position, fit the door assembly towards the end of the build in step 237 on page 43.

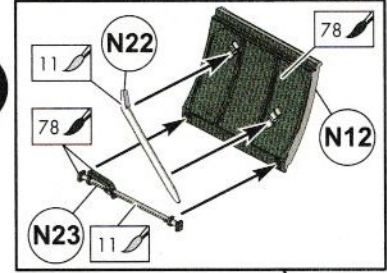
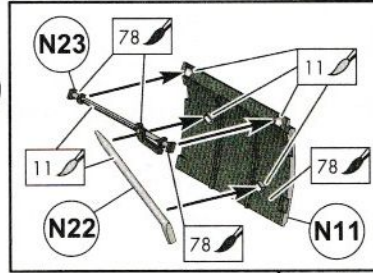
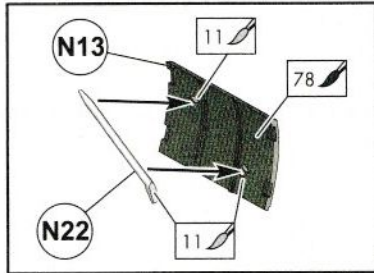
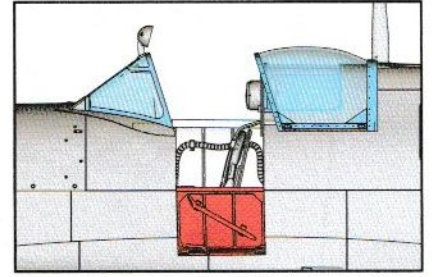
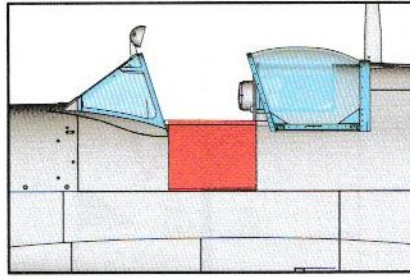
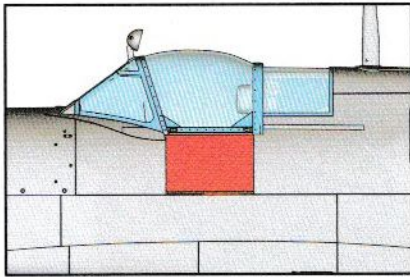

Note: Fit the open door option towards the end of the build in step 238 on page 43.

39

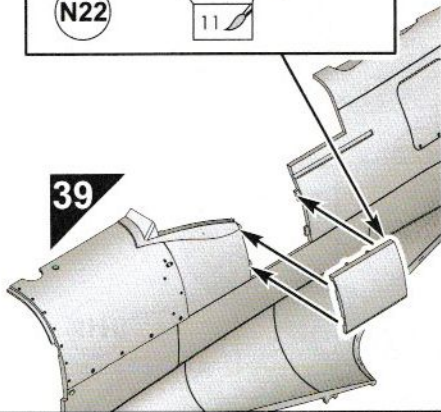

39

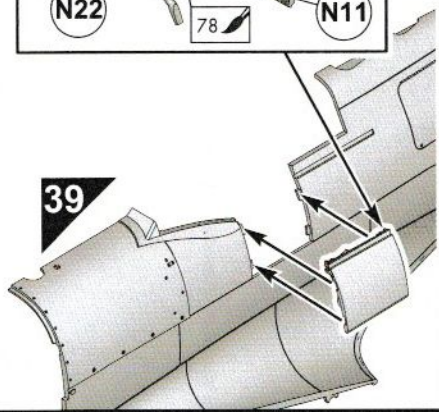

39

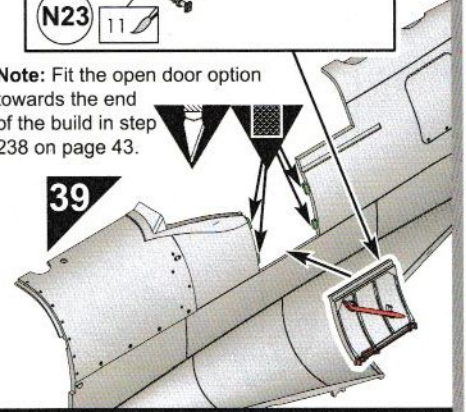

45

Some aircraft were painted Aluminium 56 instead of Cockpit Green 78

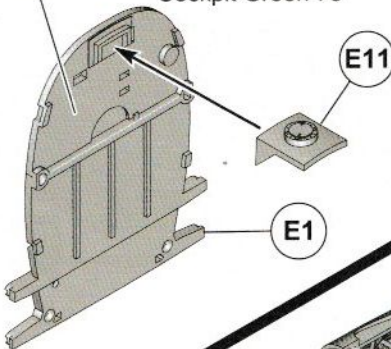

46

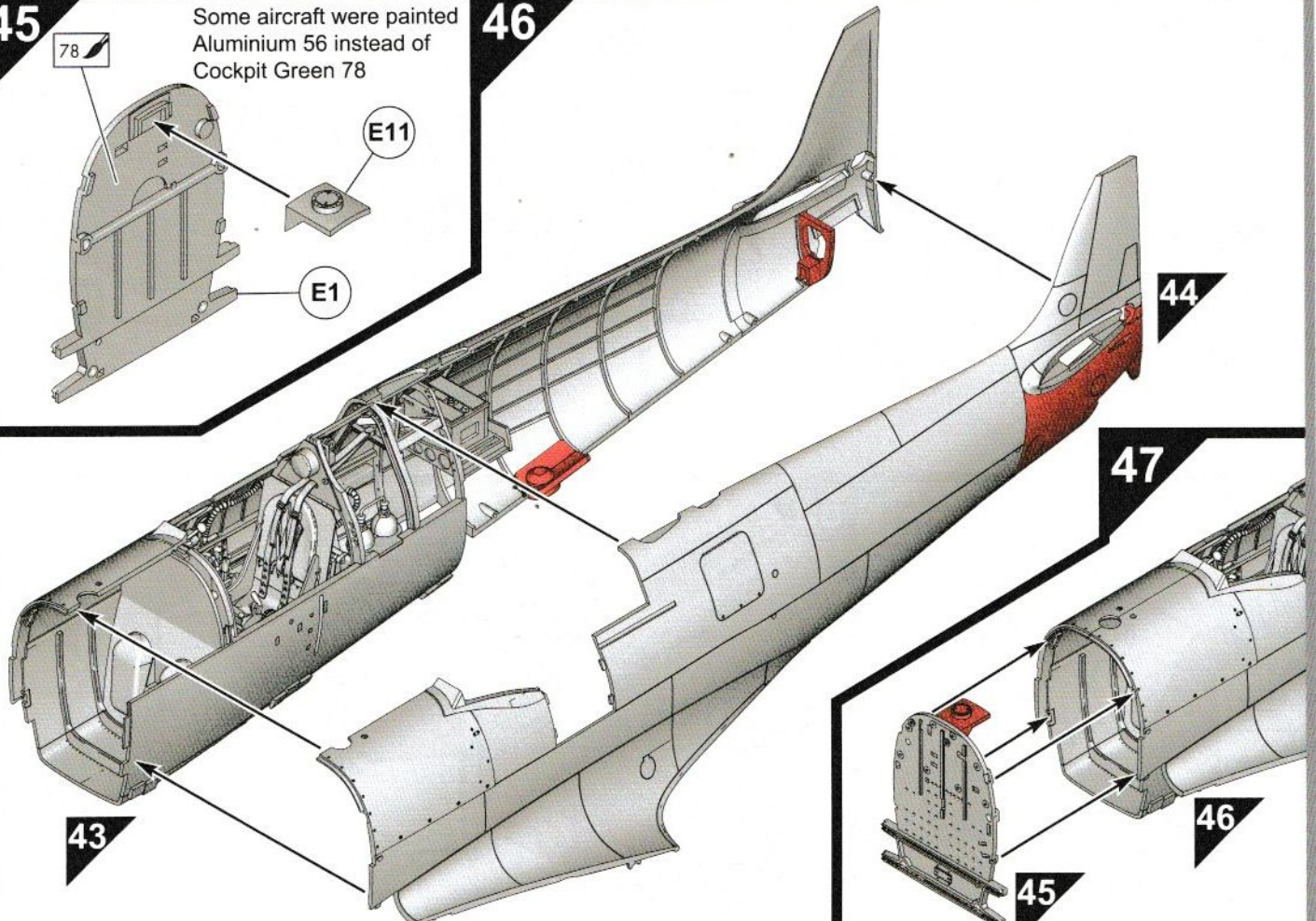

43

44

47

46

45

48a

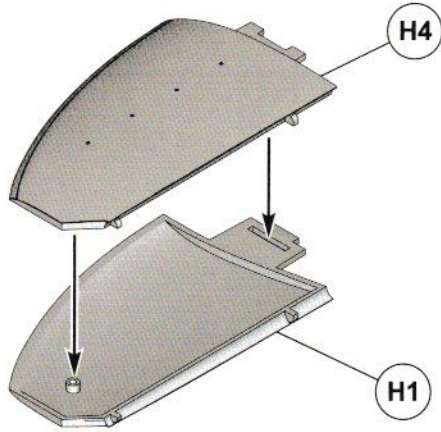

48b

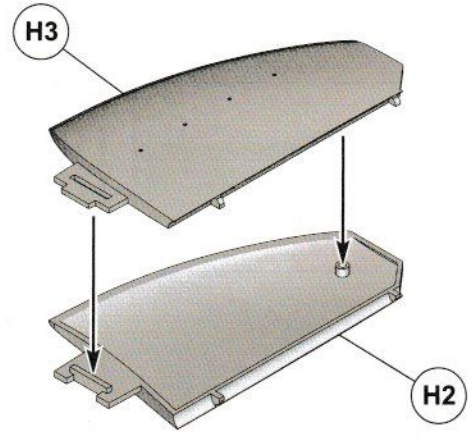

49a

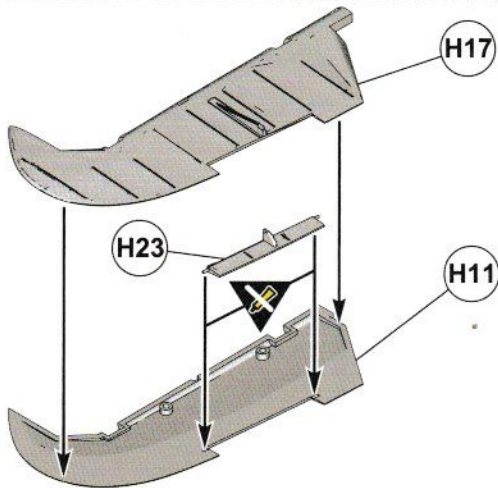

49b

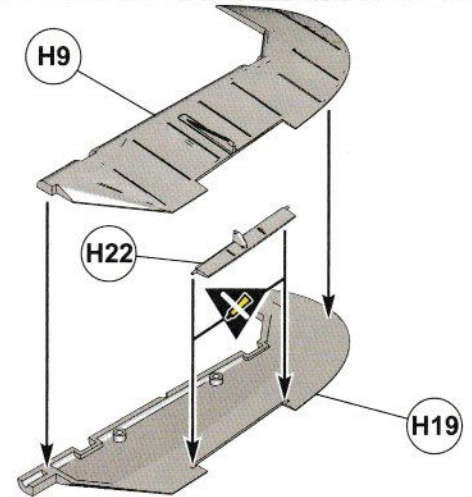

50

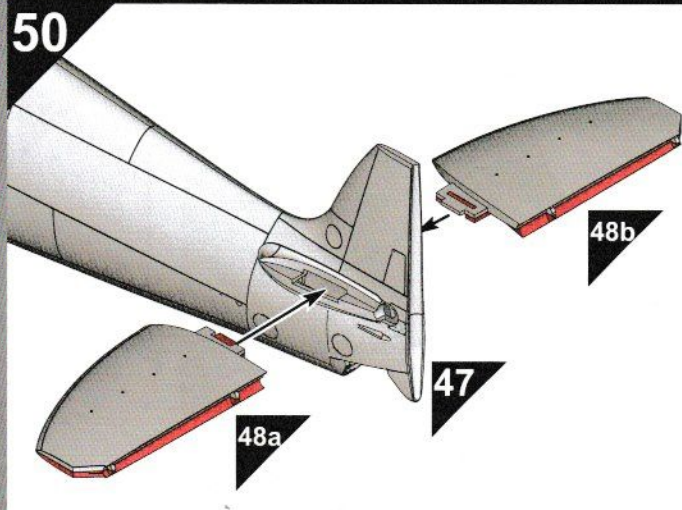

51

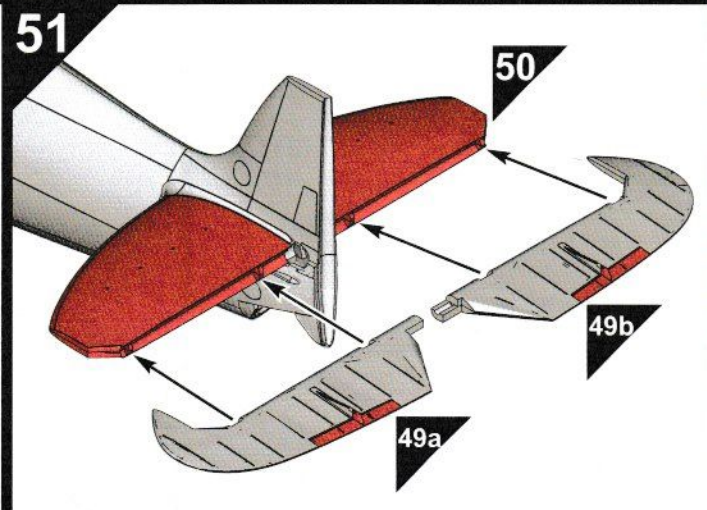

52



53

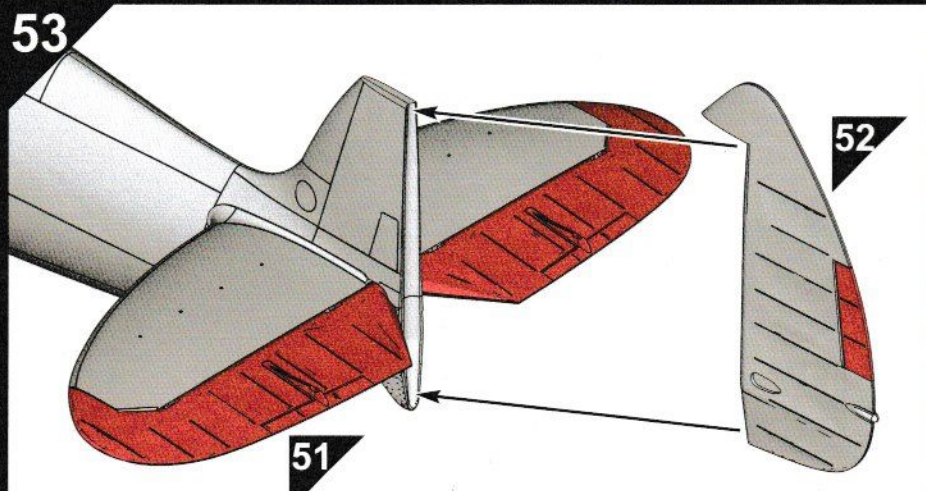

54

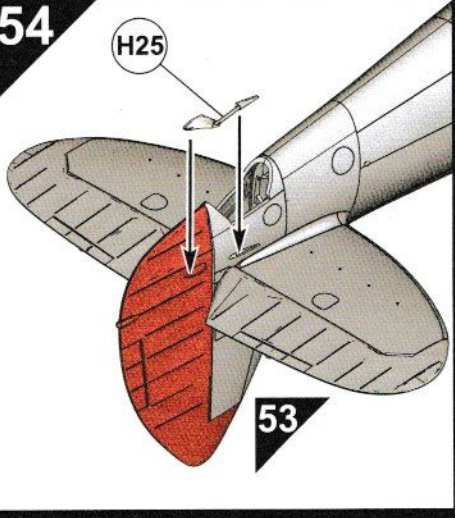

55

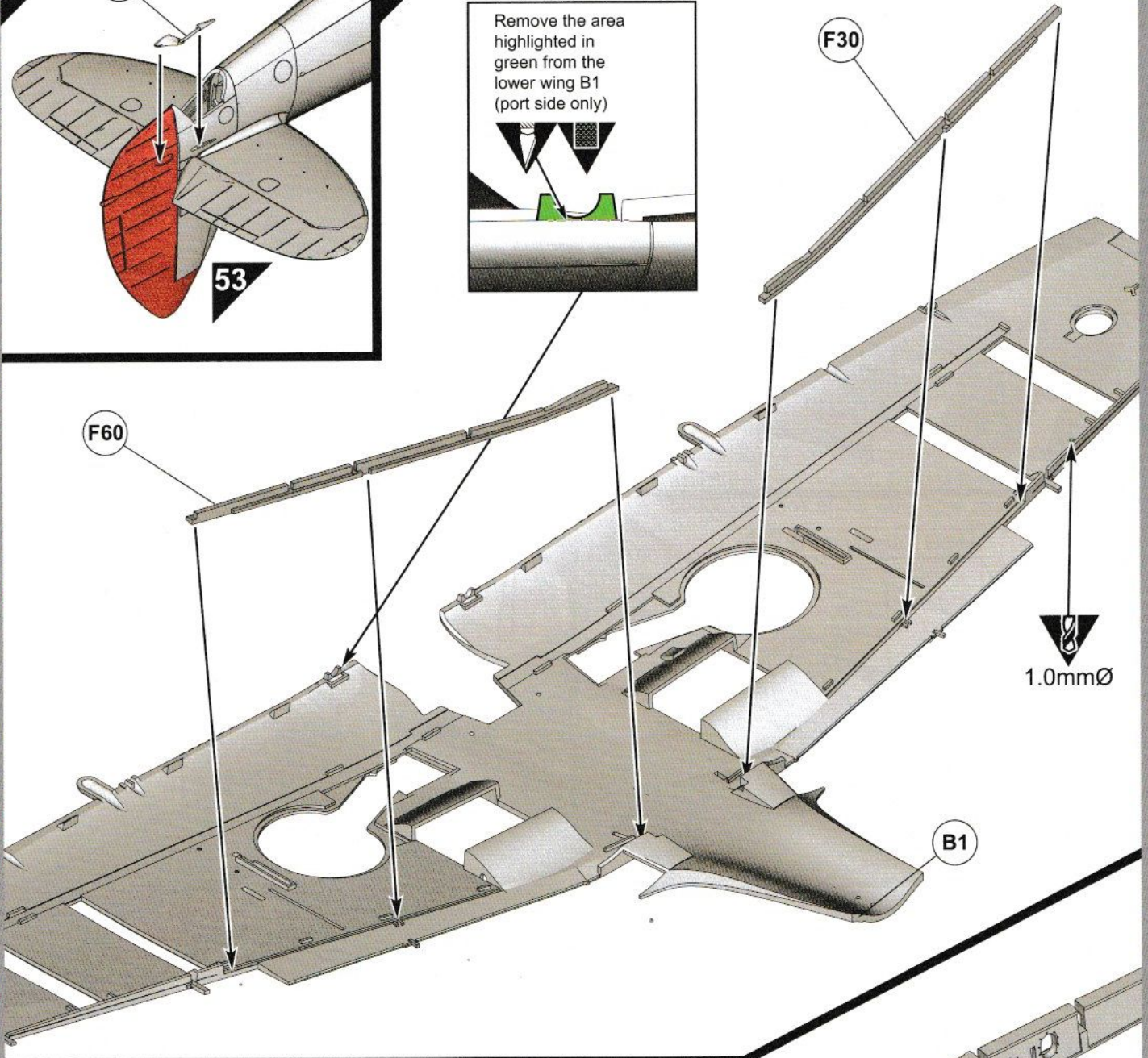
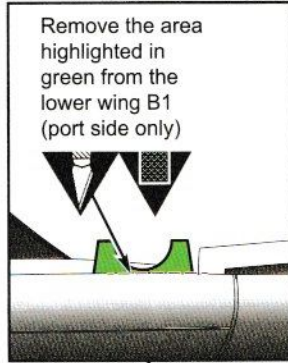

56

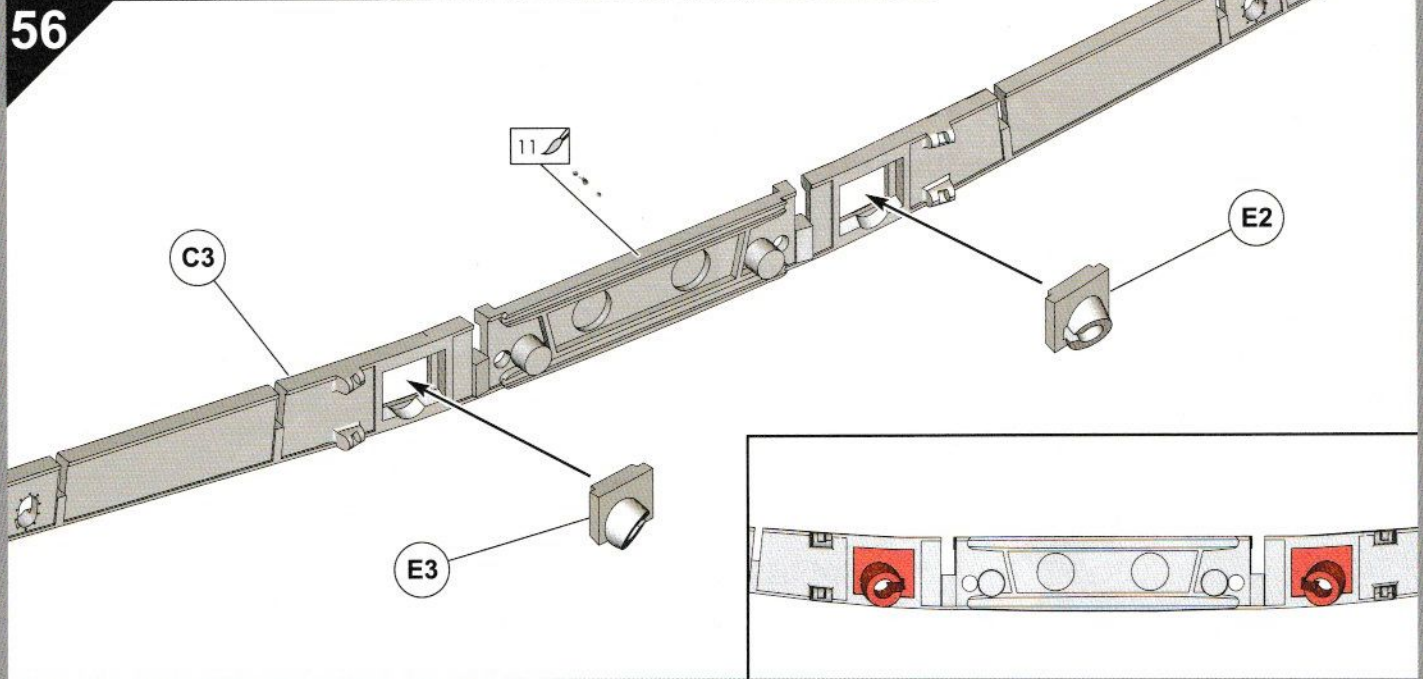

57

Note: Use sub-assembly 56 and part F33 as an alignment guide for building steps 58 to 60.
Do NOT Glue until step 65 on page 15.

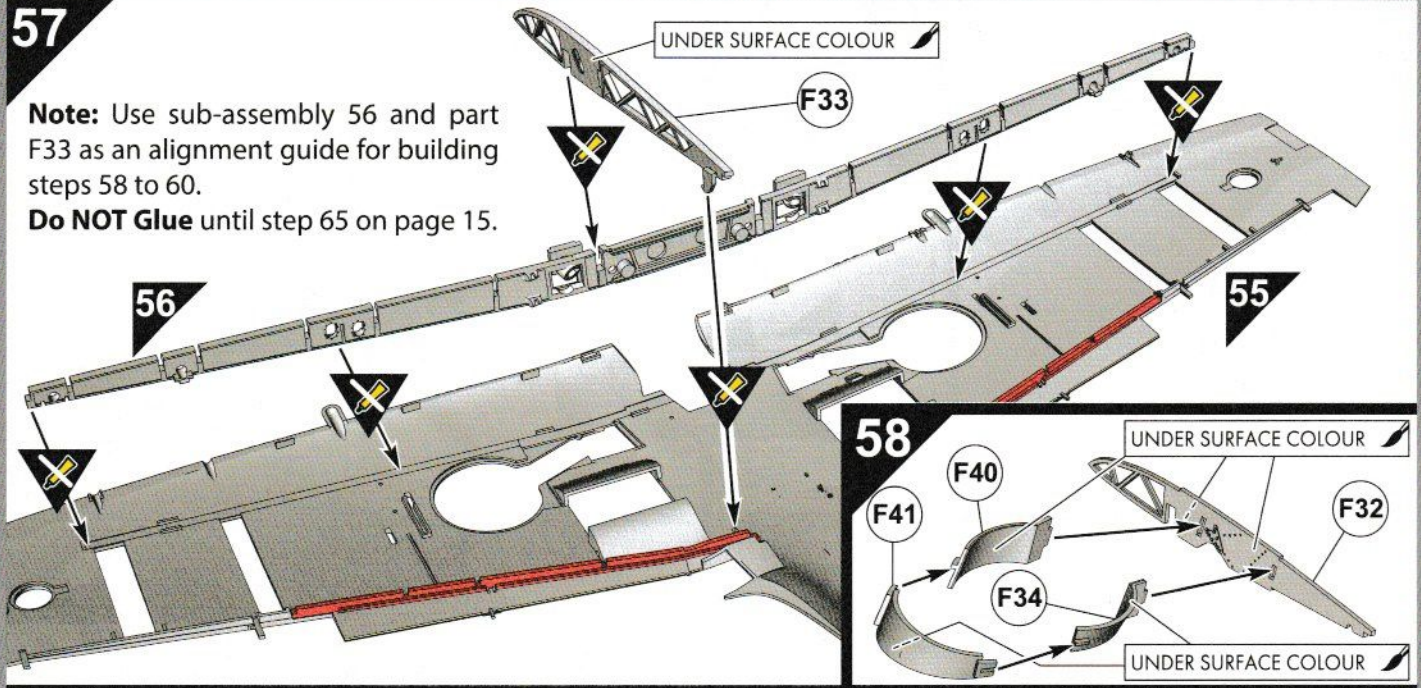
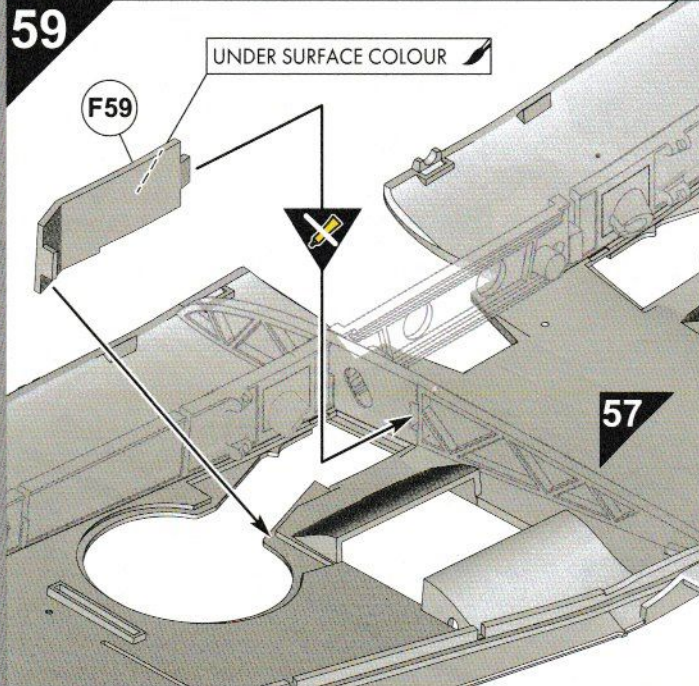
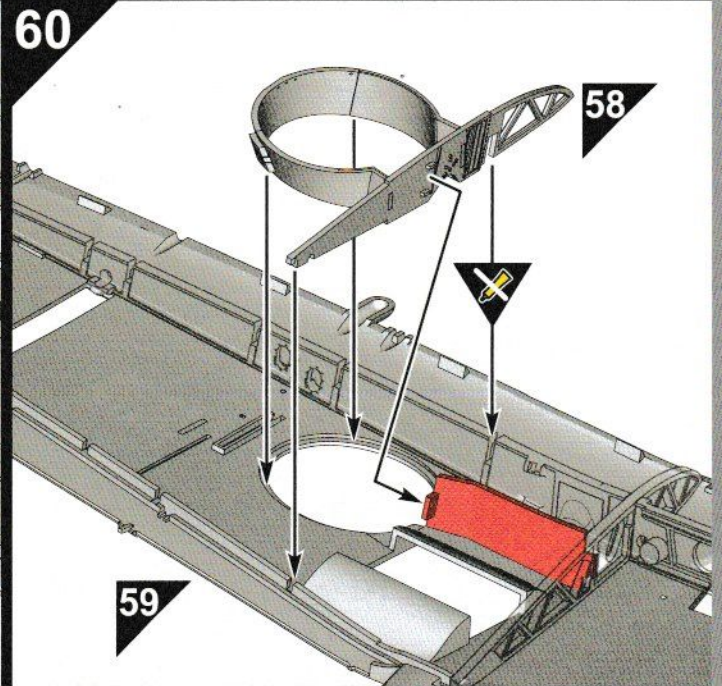
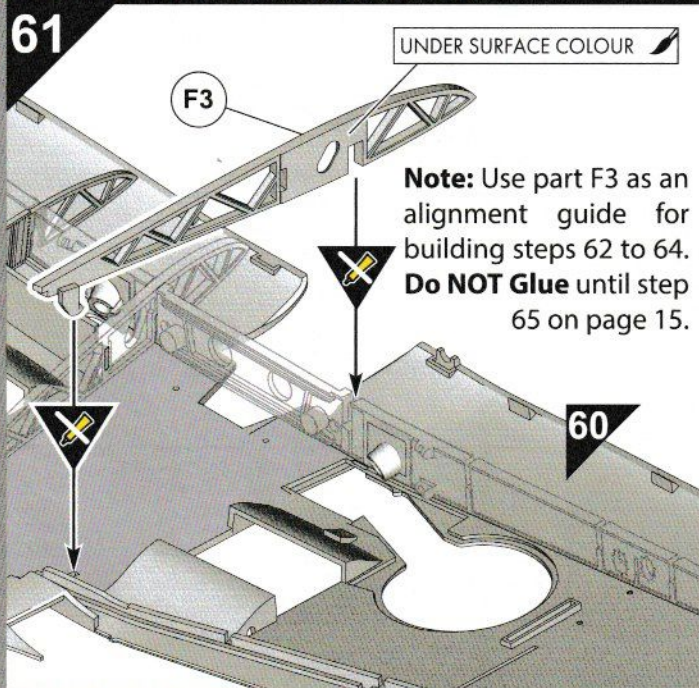
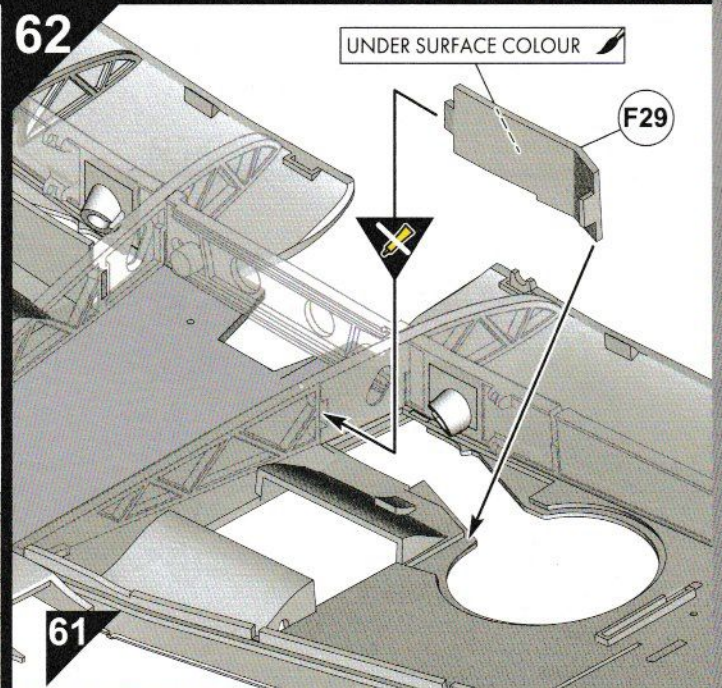
**59****60****61****62**

Note: Use part F3 as an alignment guide for building steps 62 to 64.
Do NOT Glue until step 65 on page 15.

63

UNDER SURFACE COLOUR

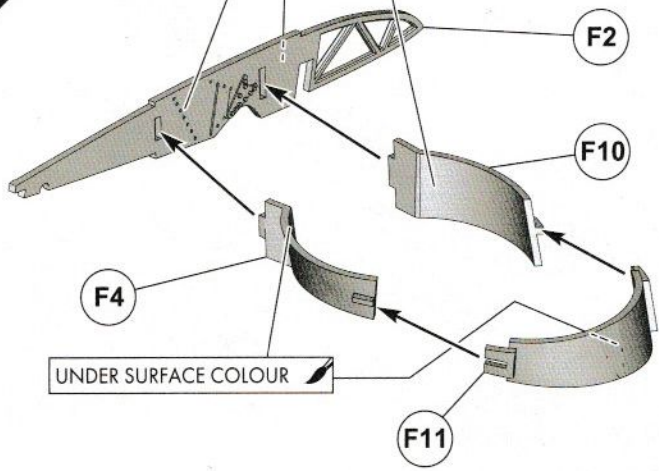

64

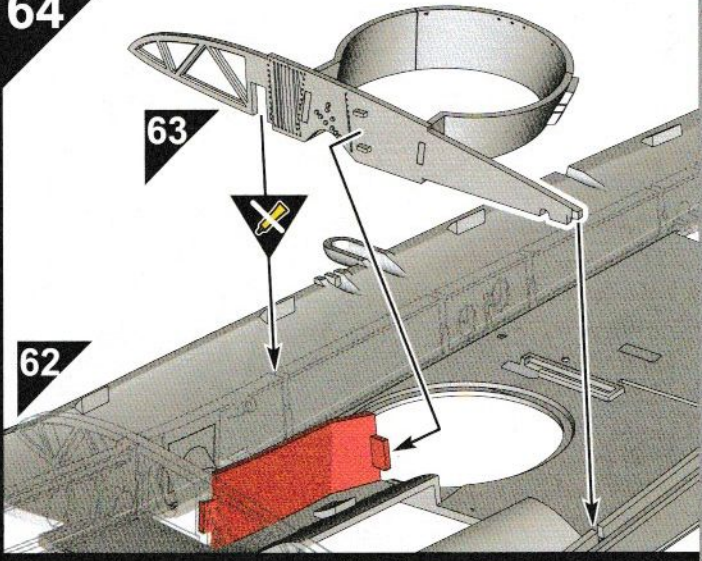

65

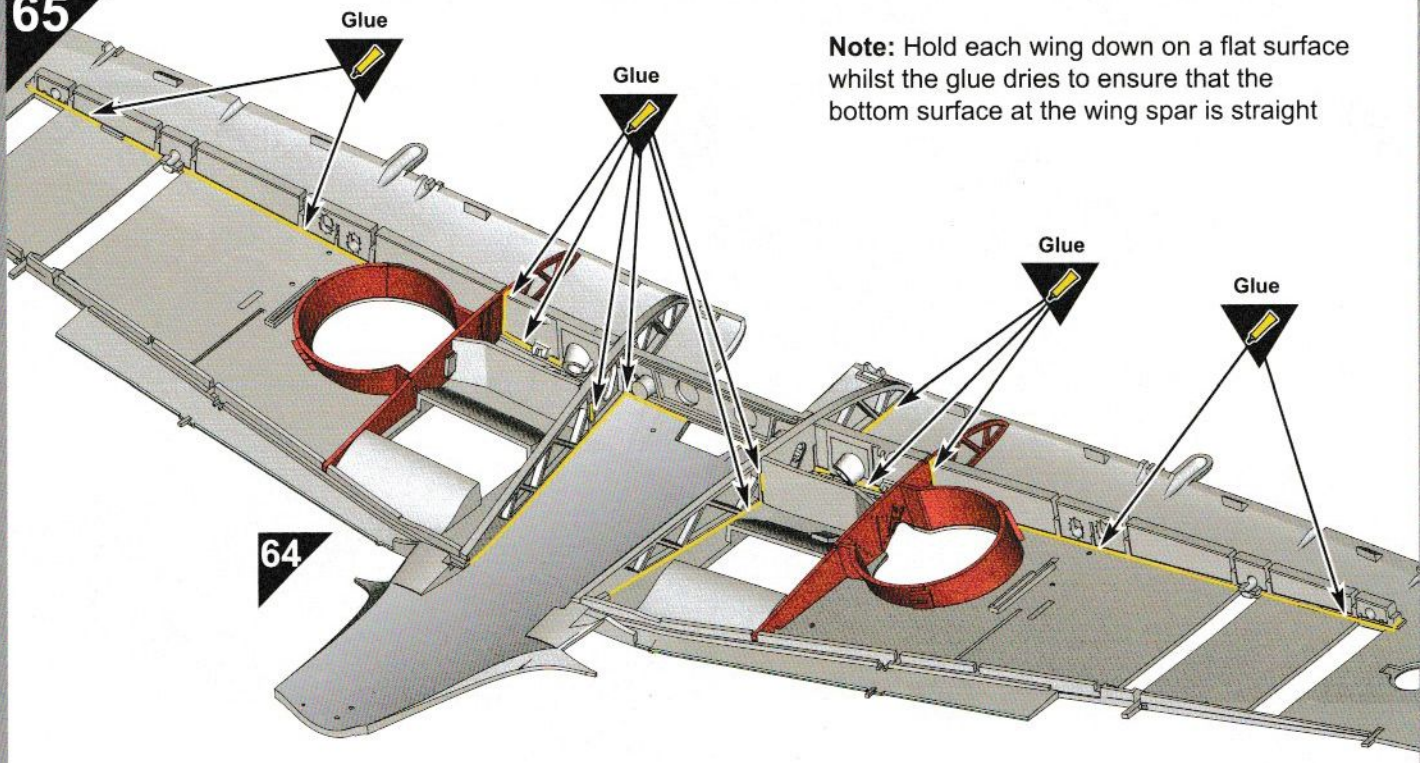

66

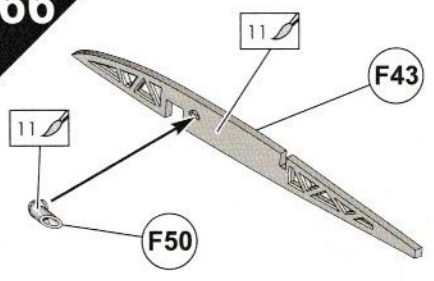

67

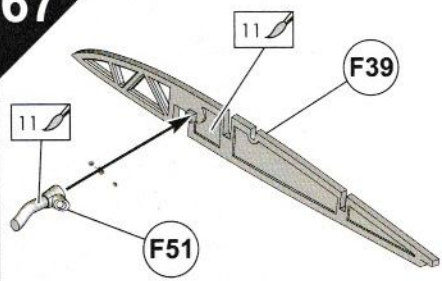

68

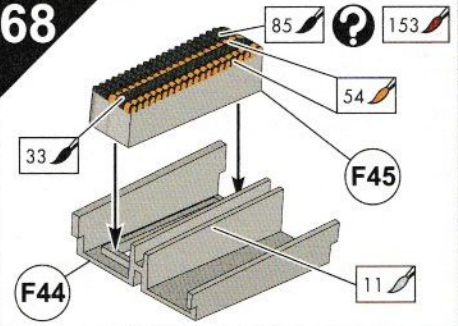

69

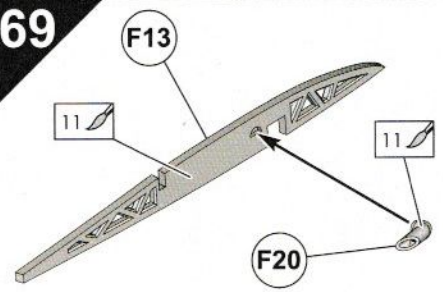

70

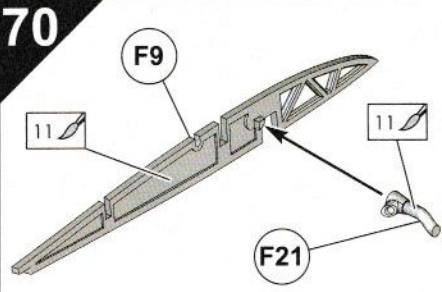

71

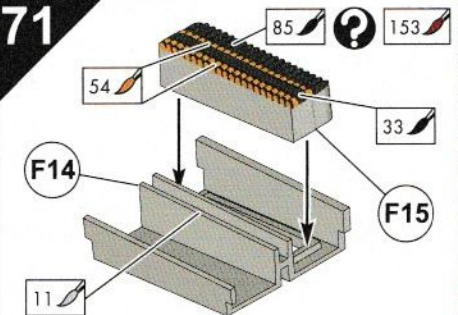

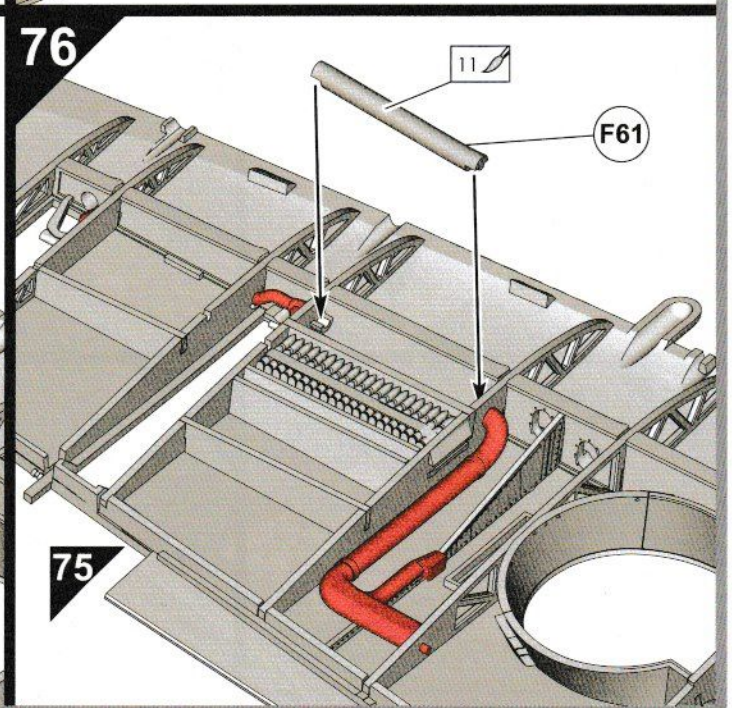
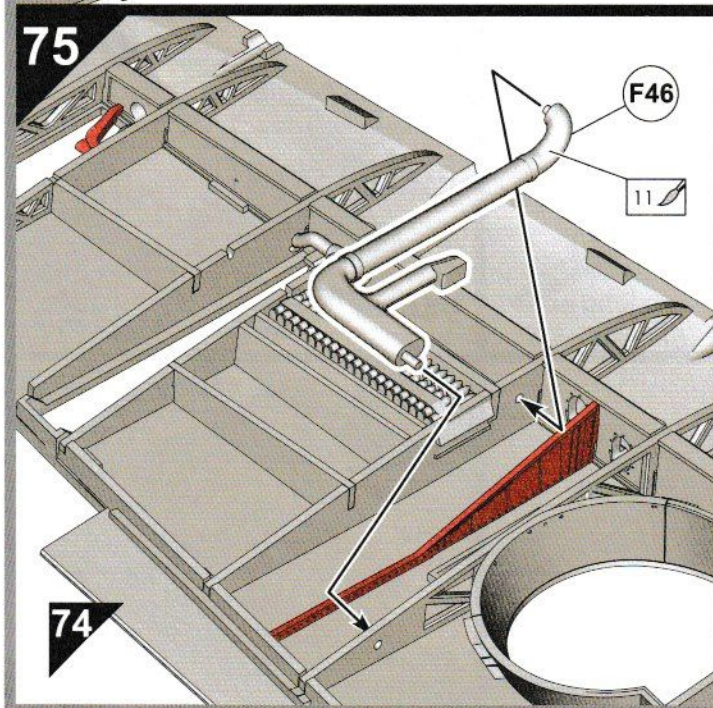
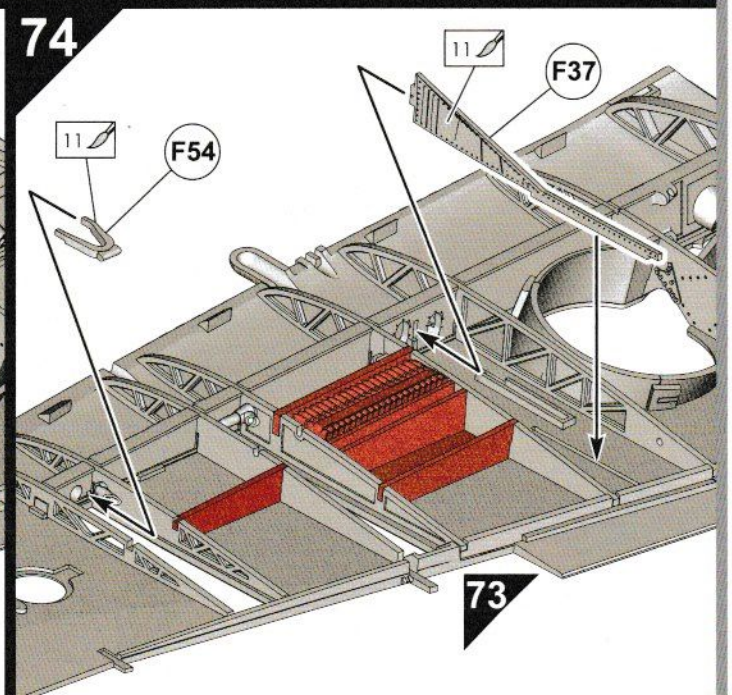
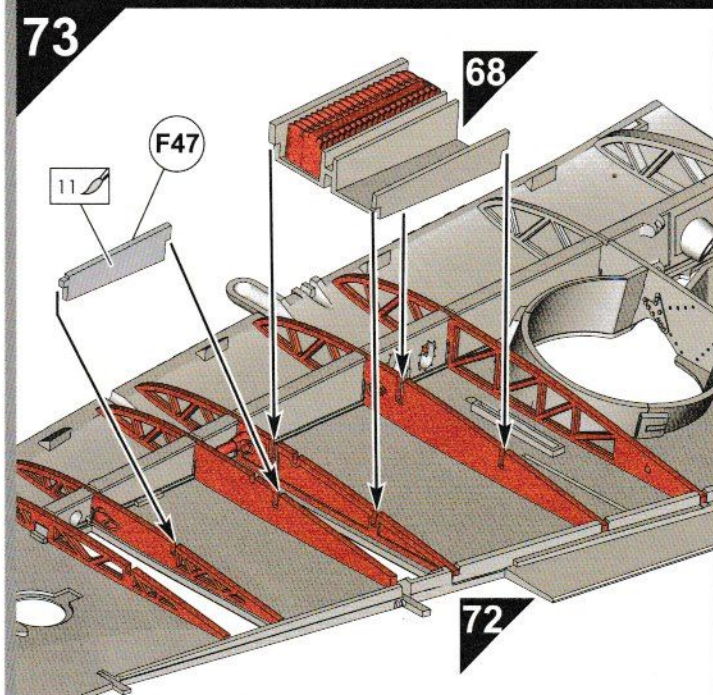
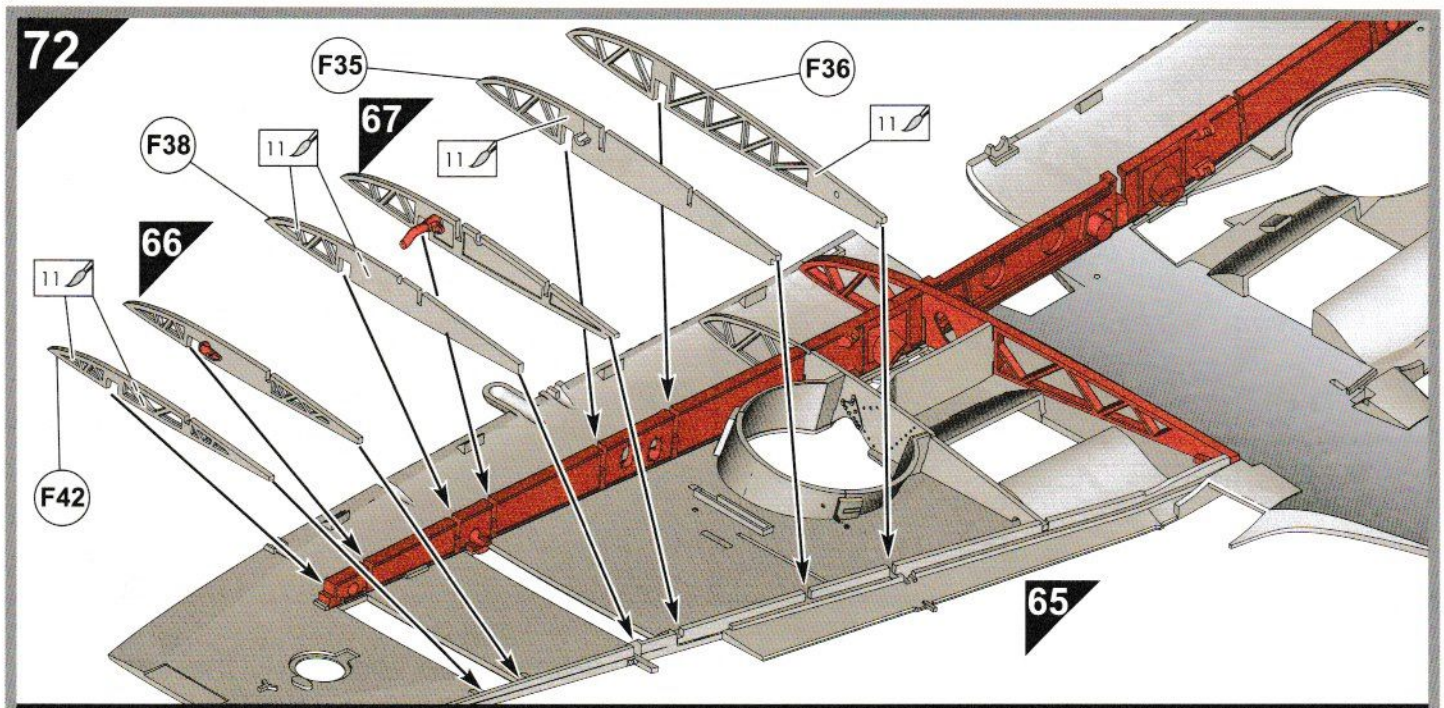

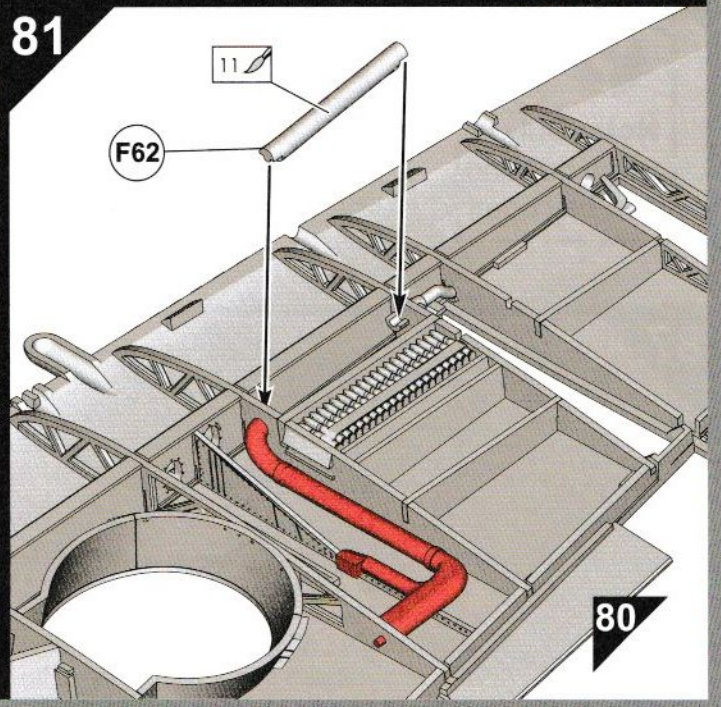
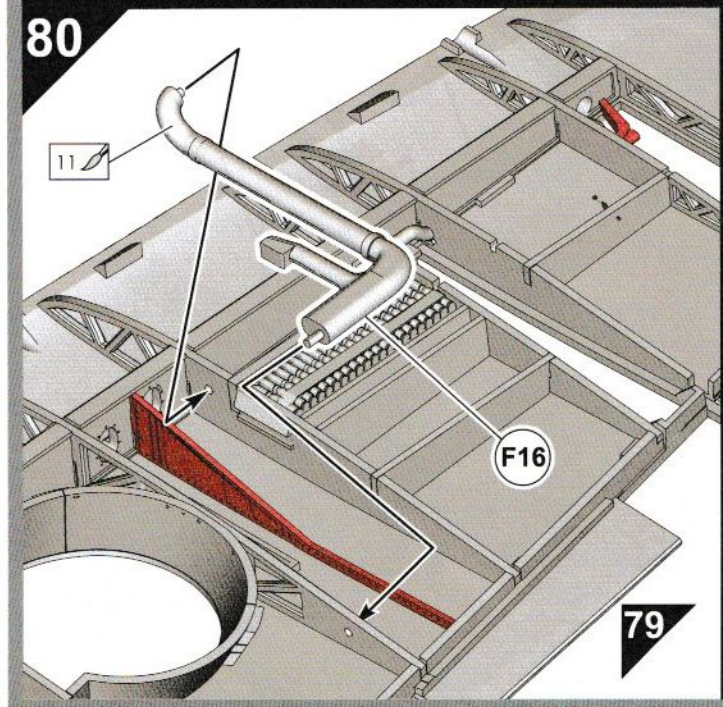
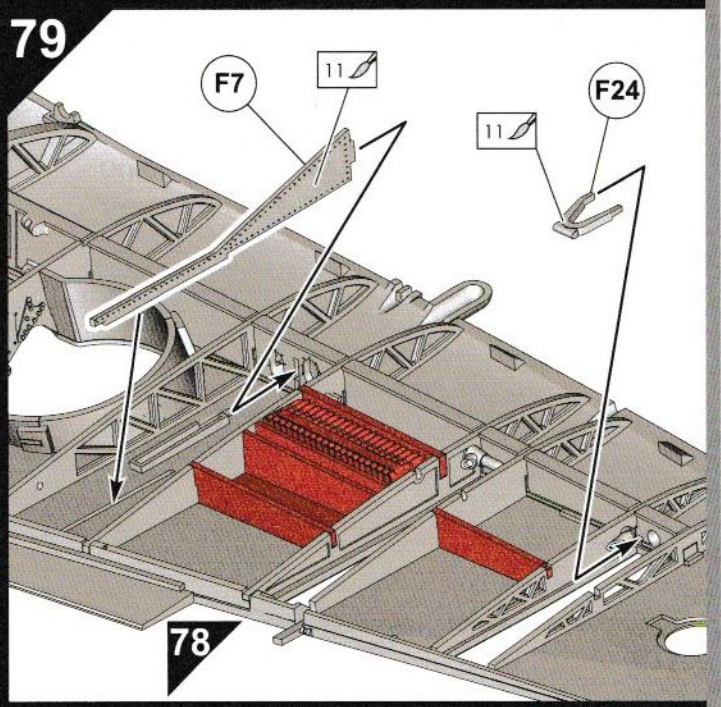
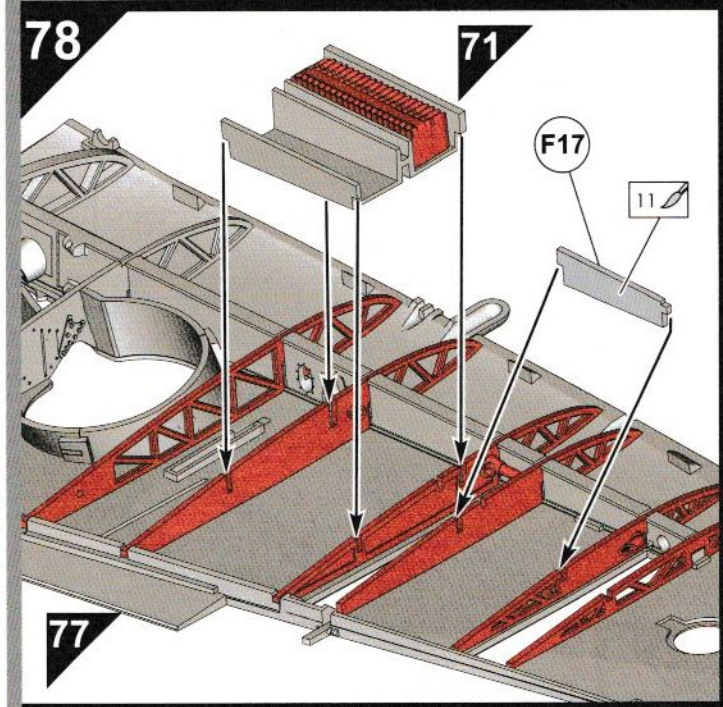
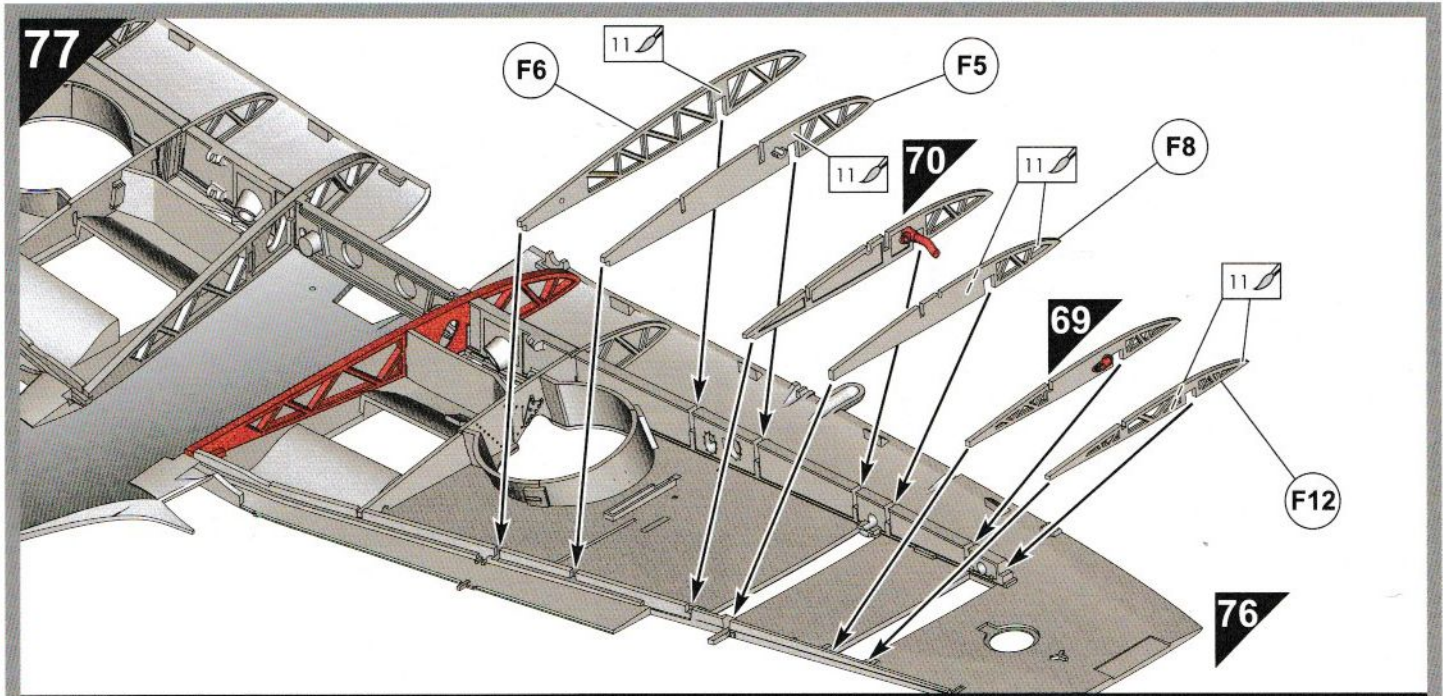

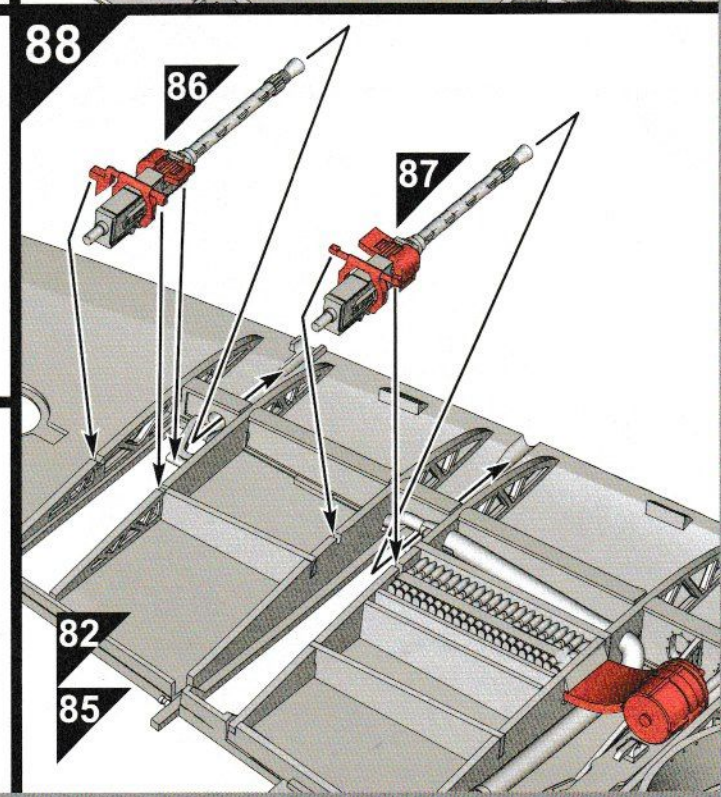
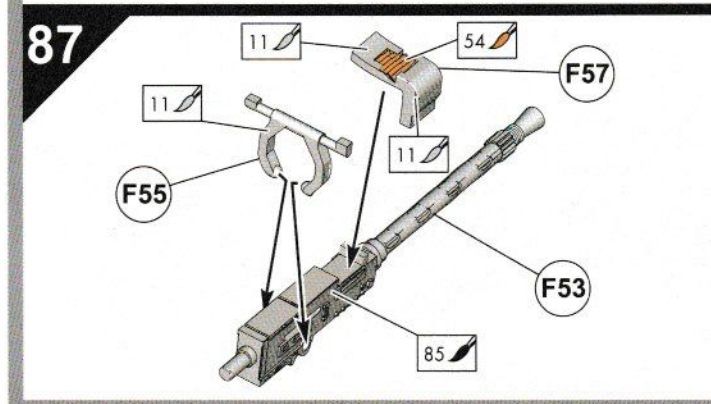
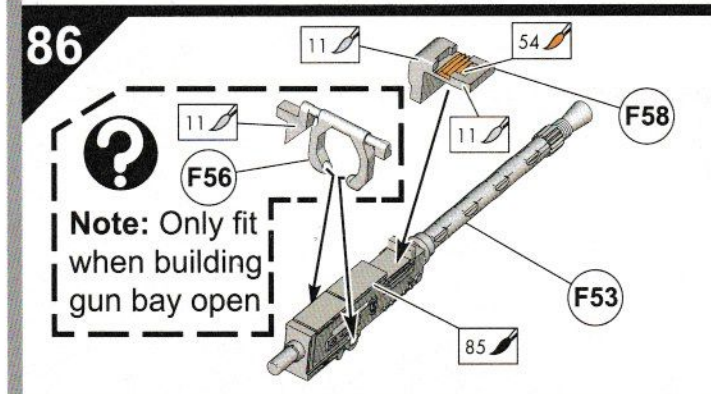
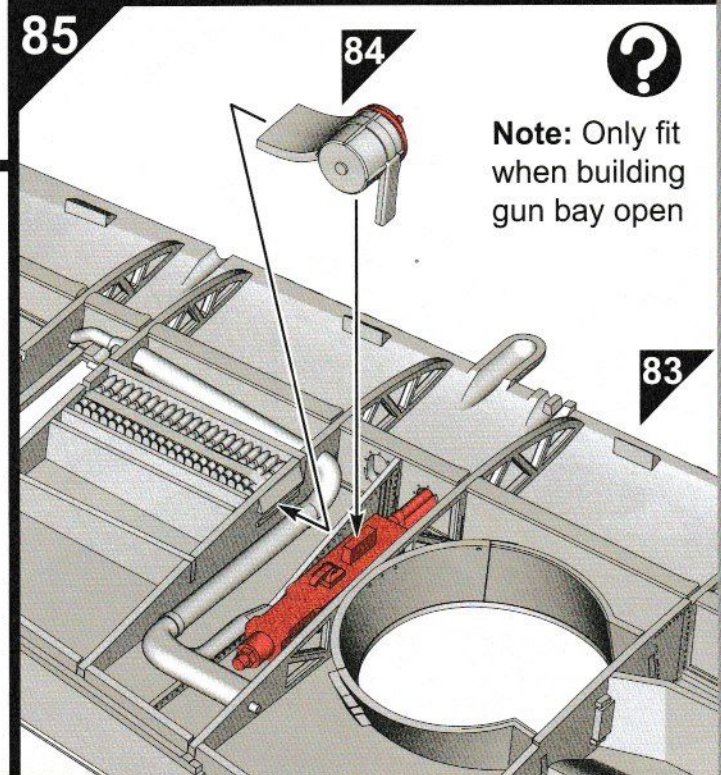
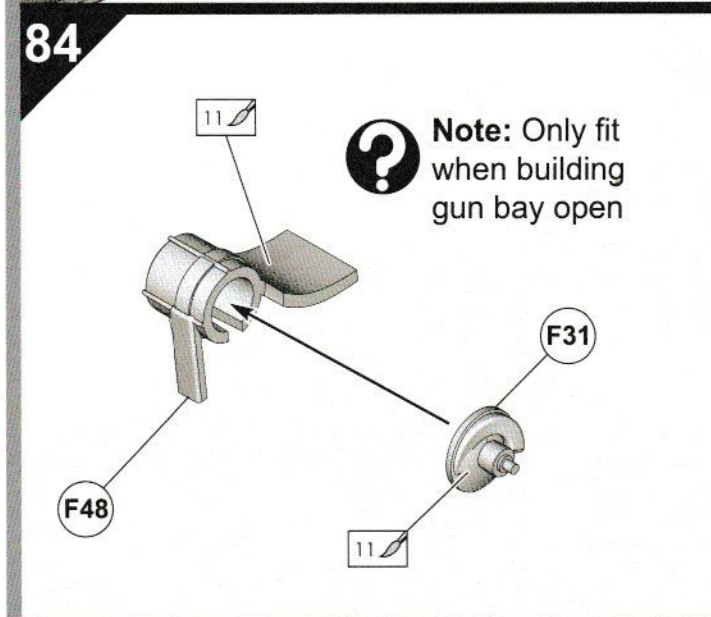
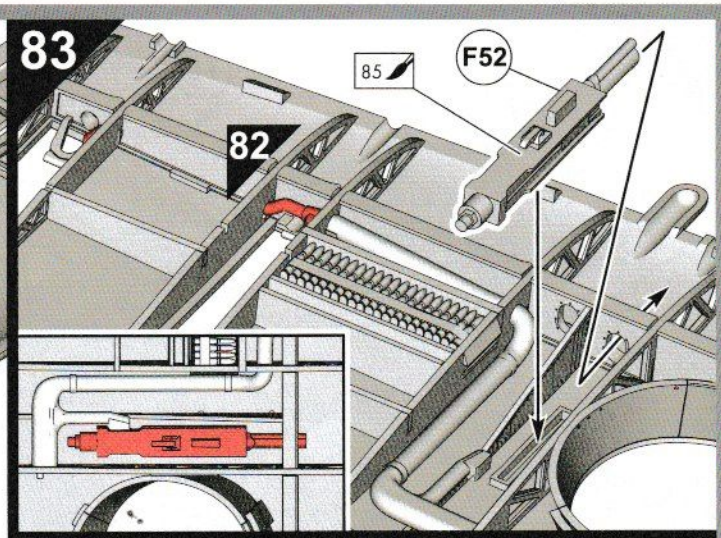
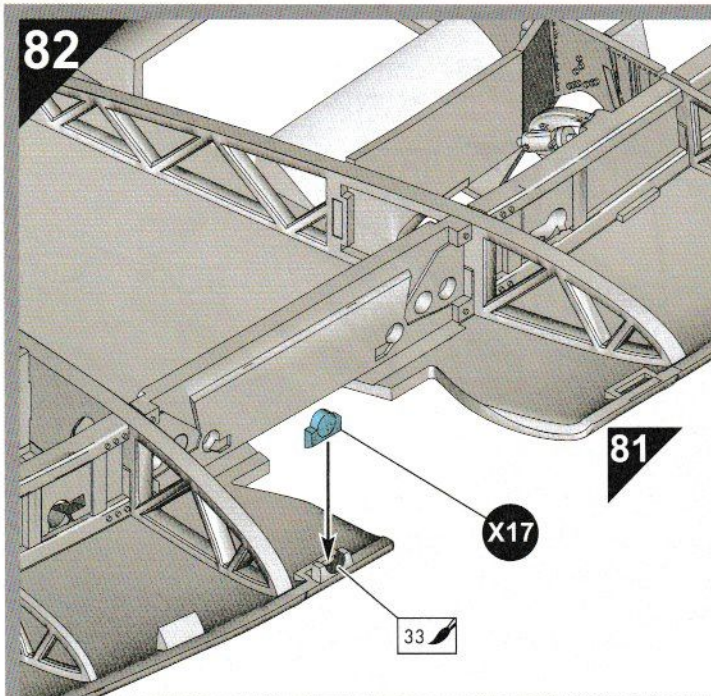

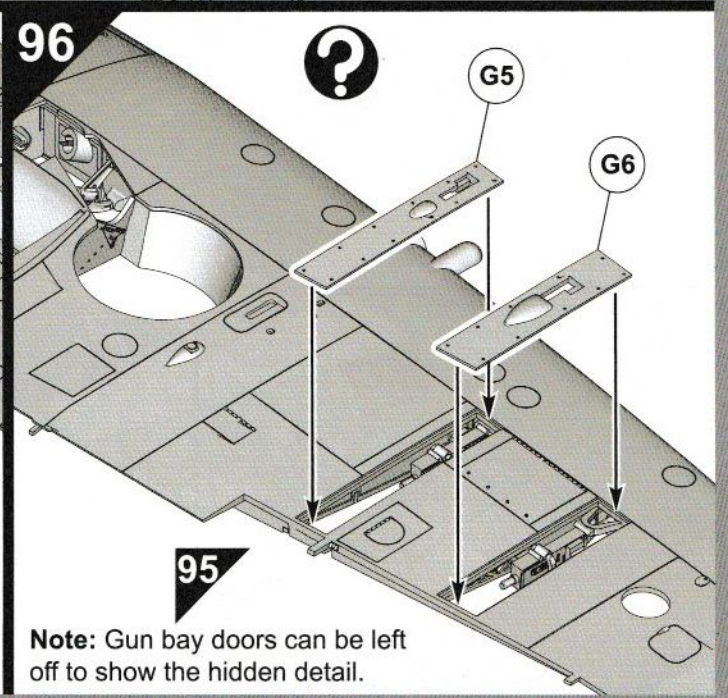
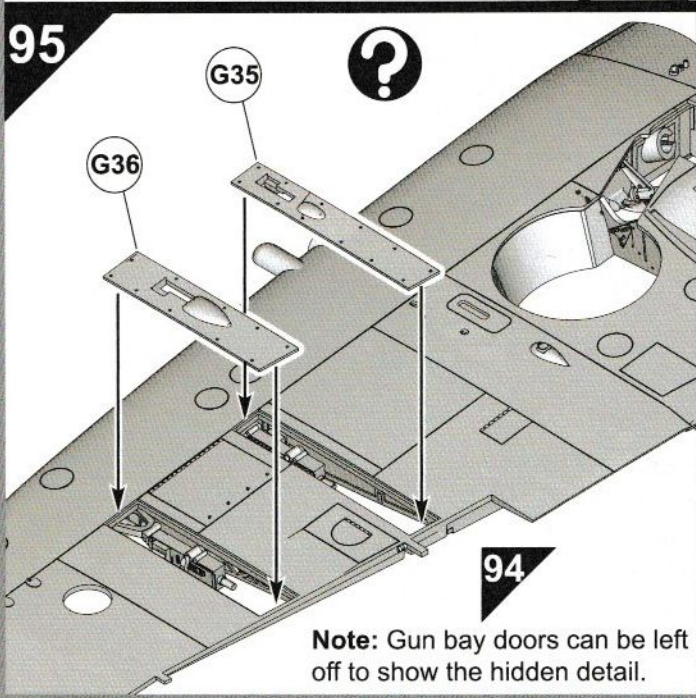
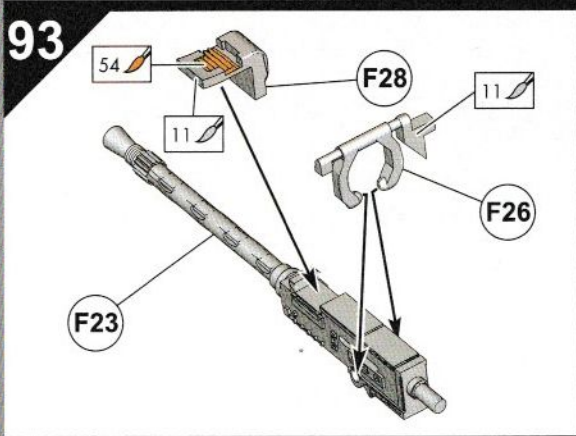
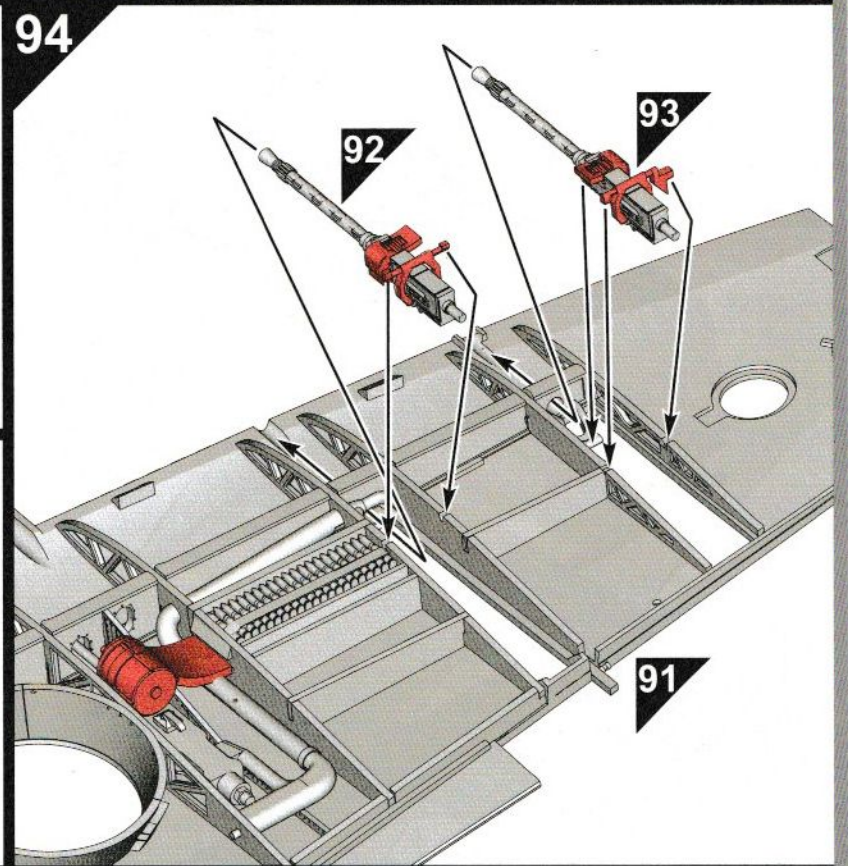
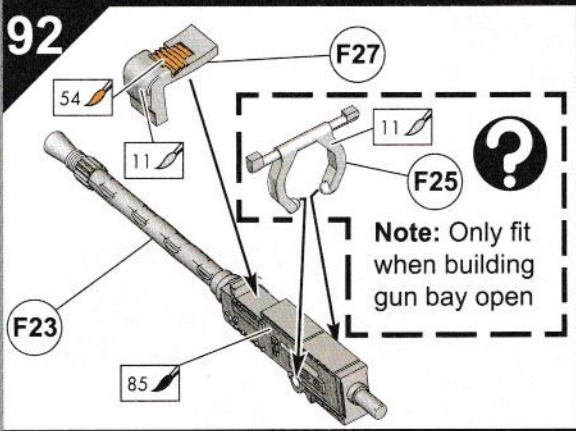
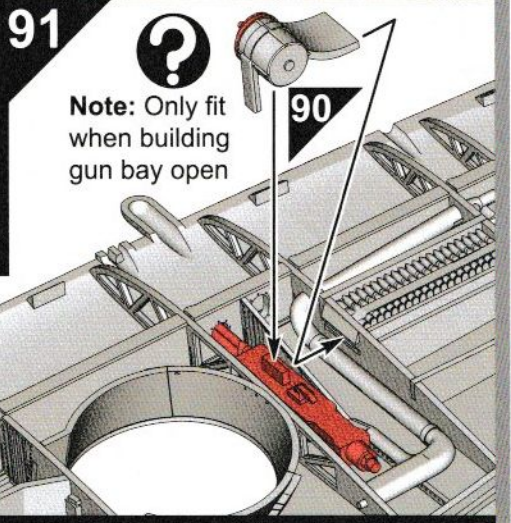
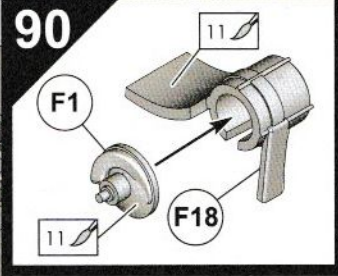
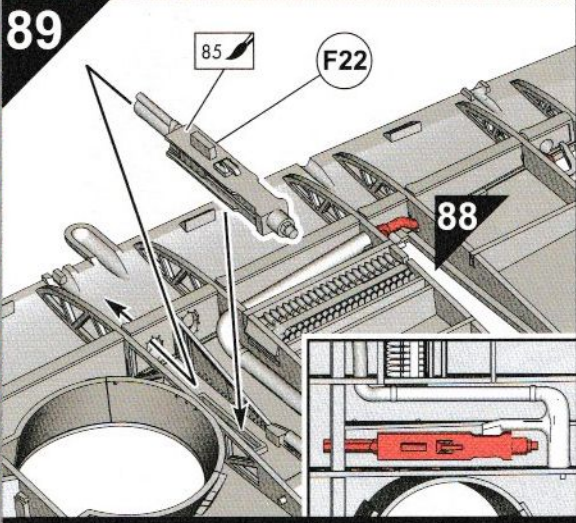

97

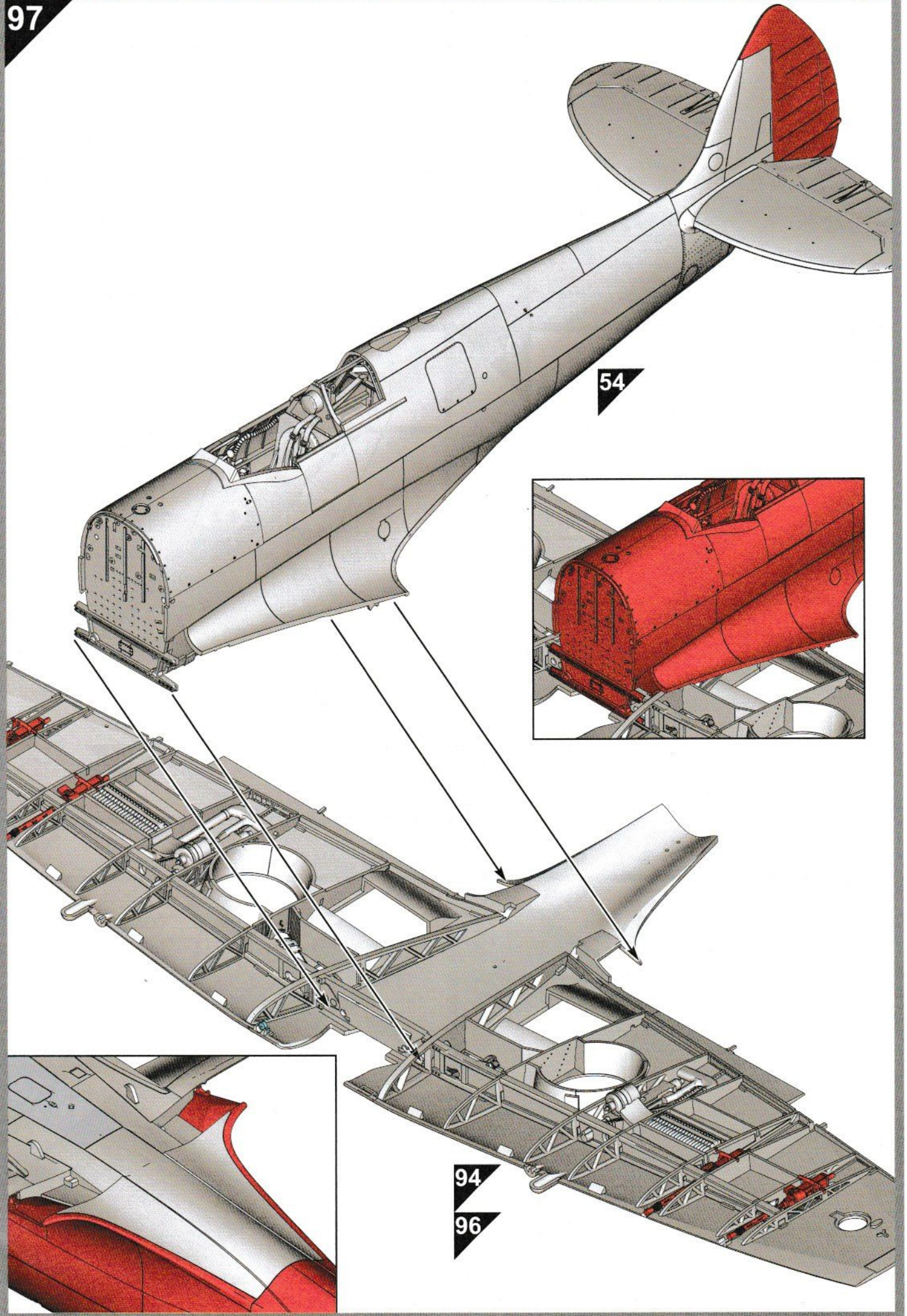

98

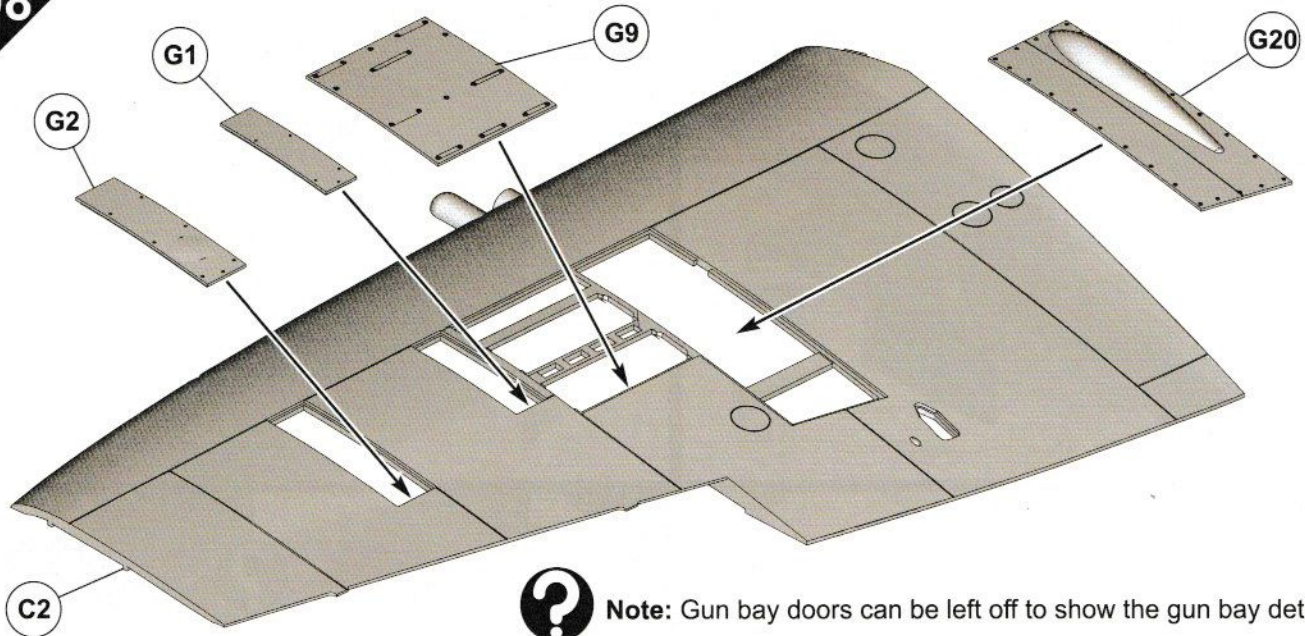

Note: Gun bay doors can be left off to show the gun bay detail.

99

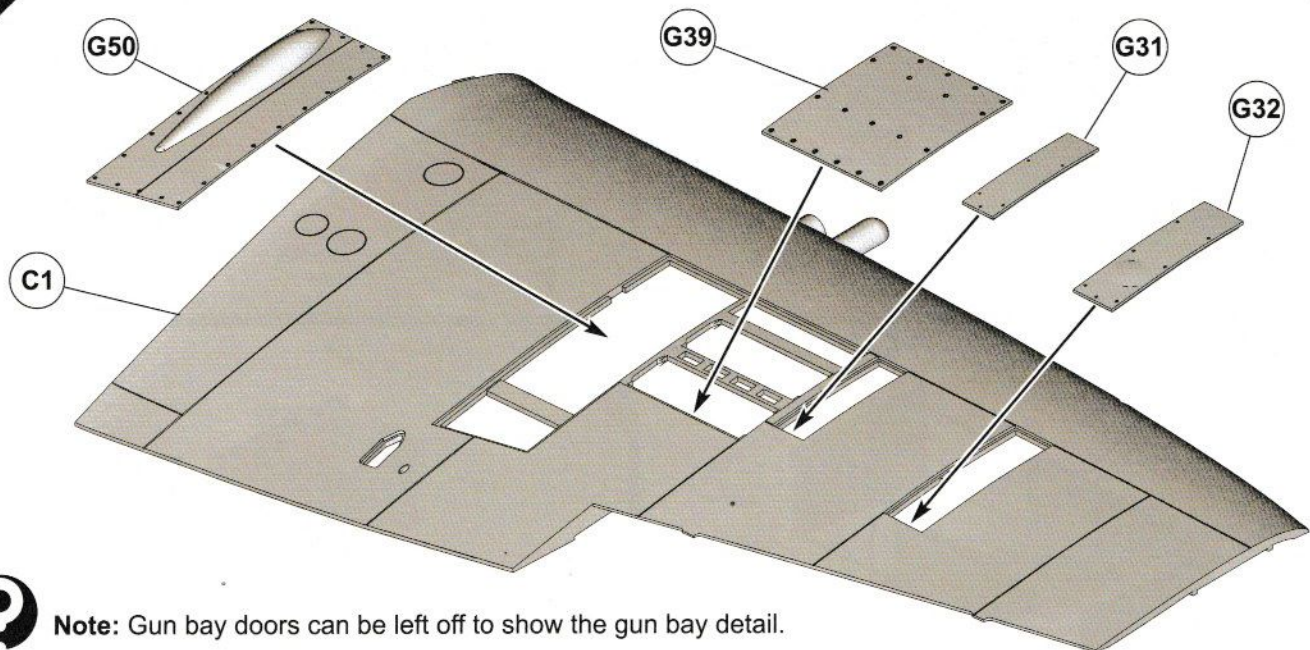

Note: Gun bay doors can be left off to show the gun bay detail.

100

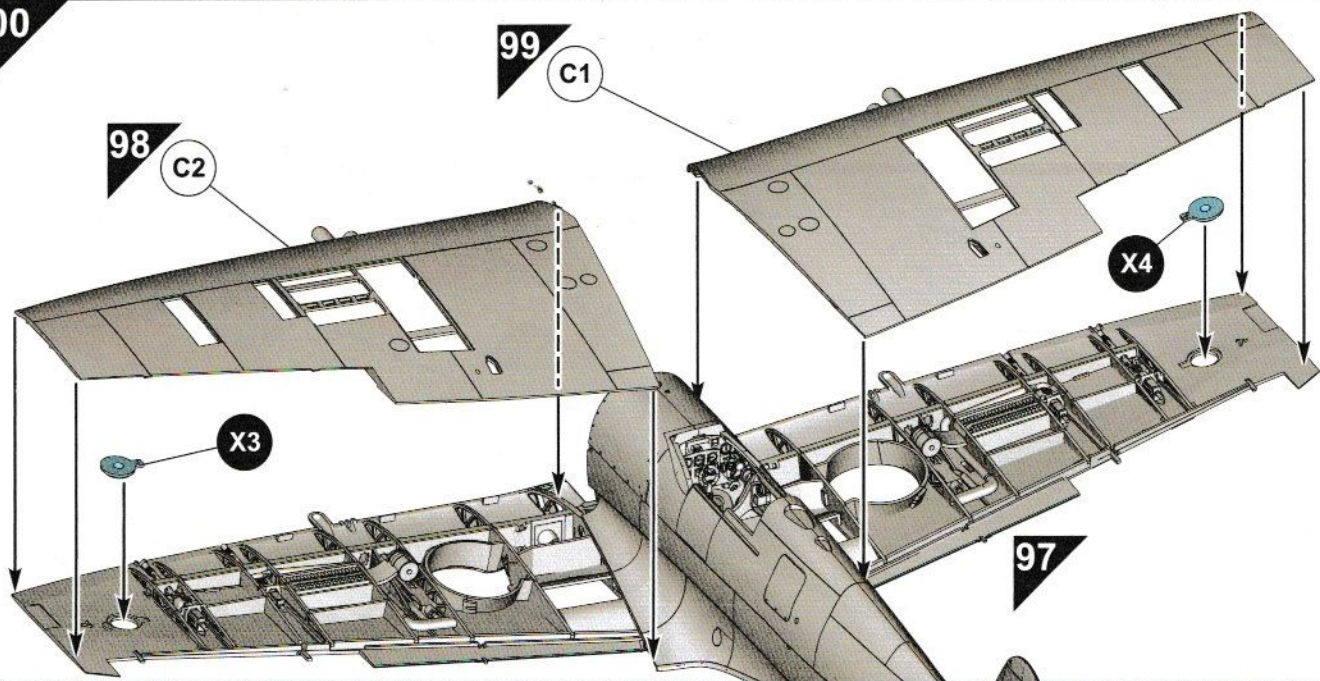

101

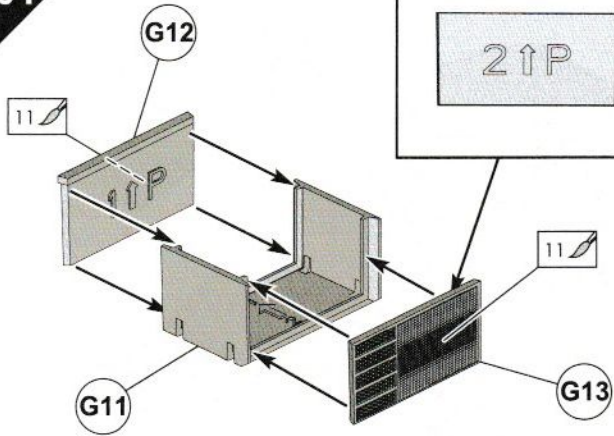

102

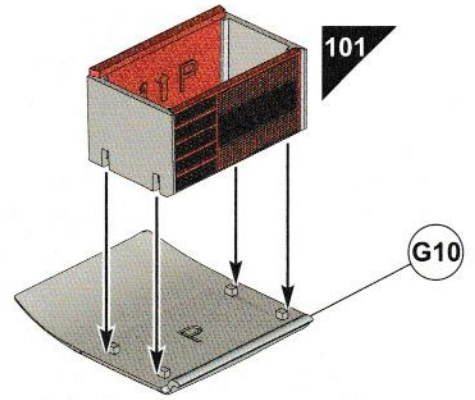

103

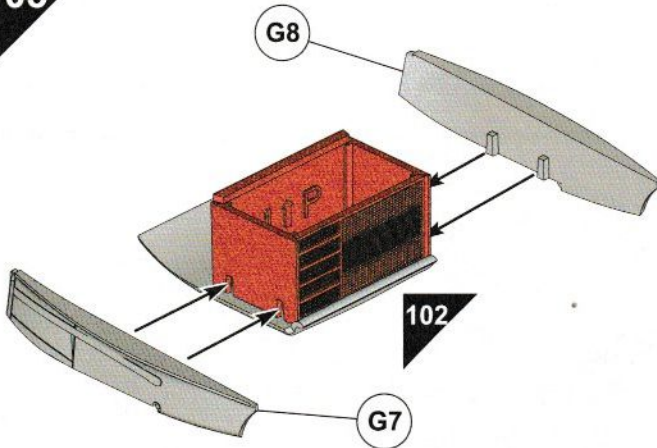

104

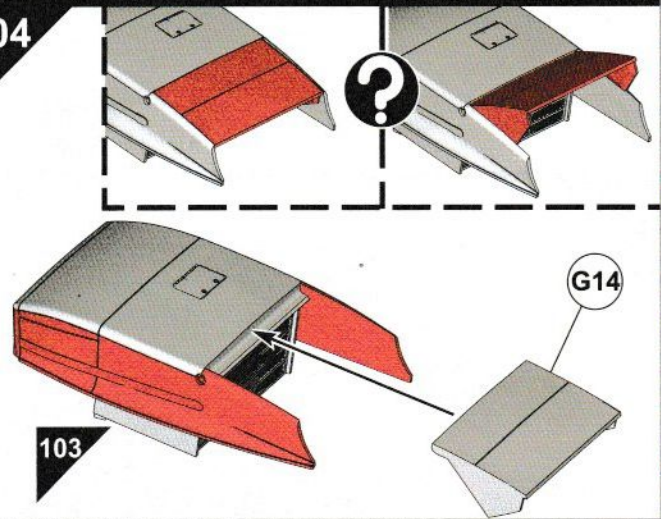

105

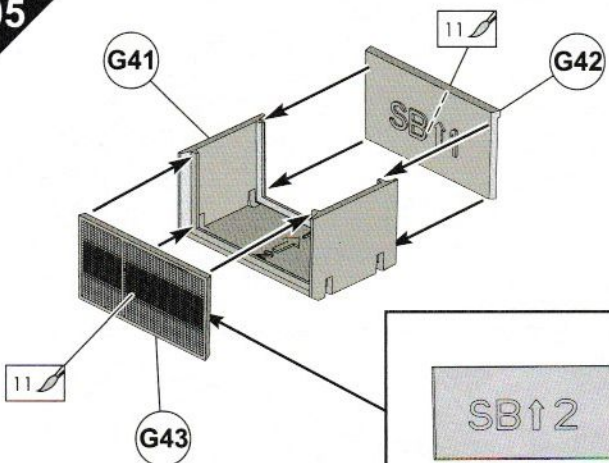

106

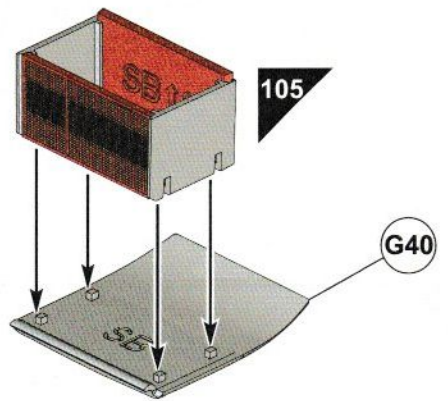

107

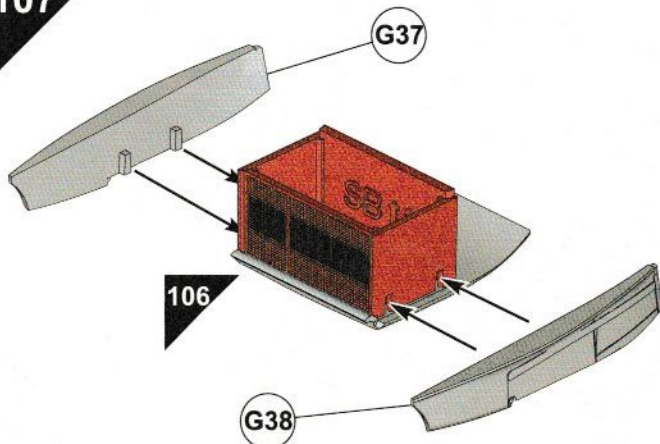

108

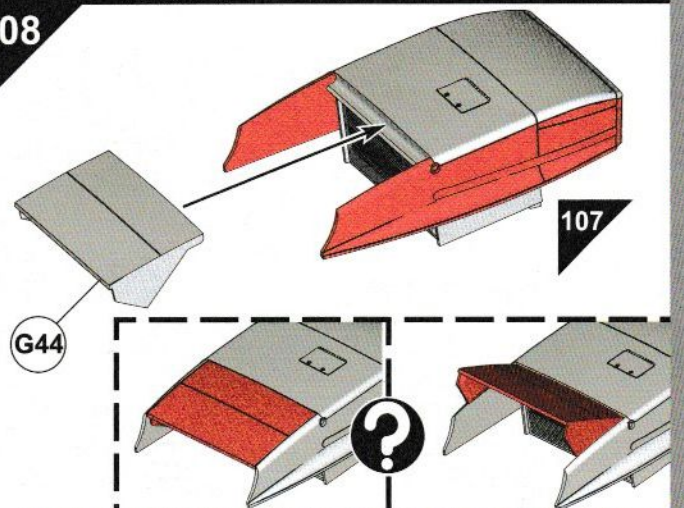

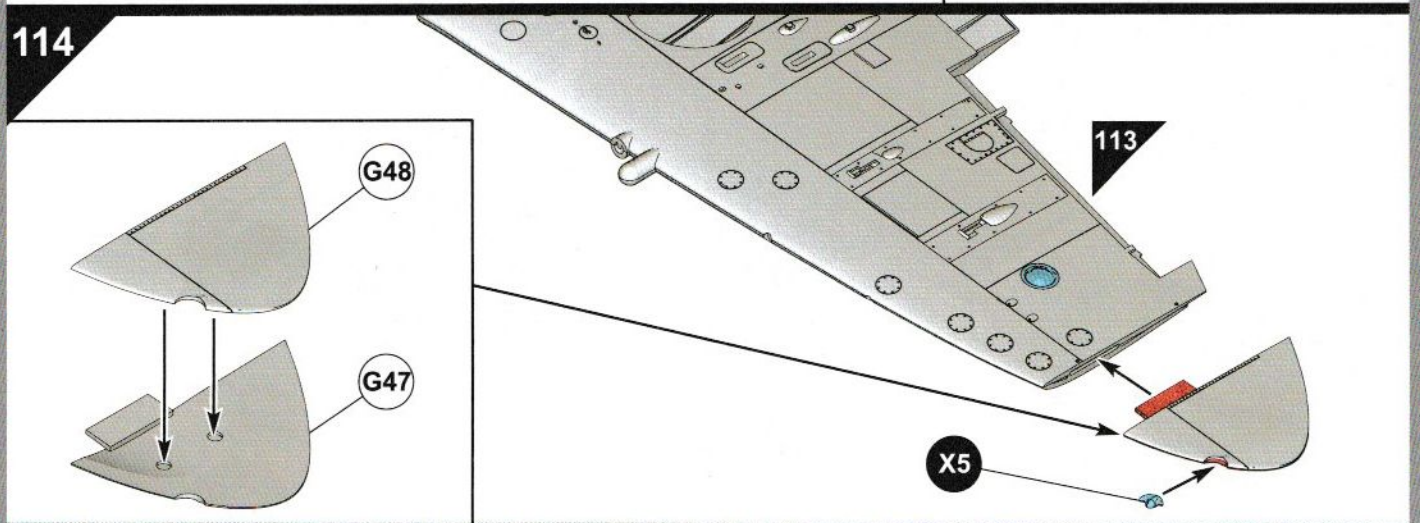
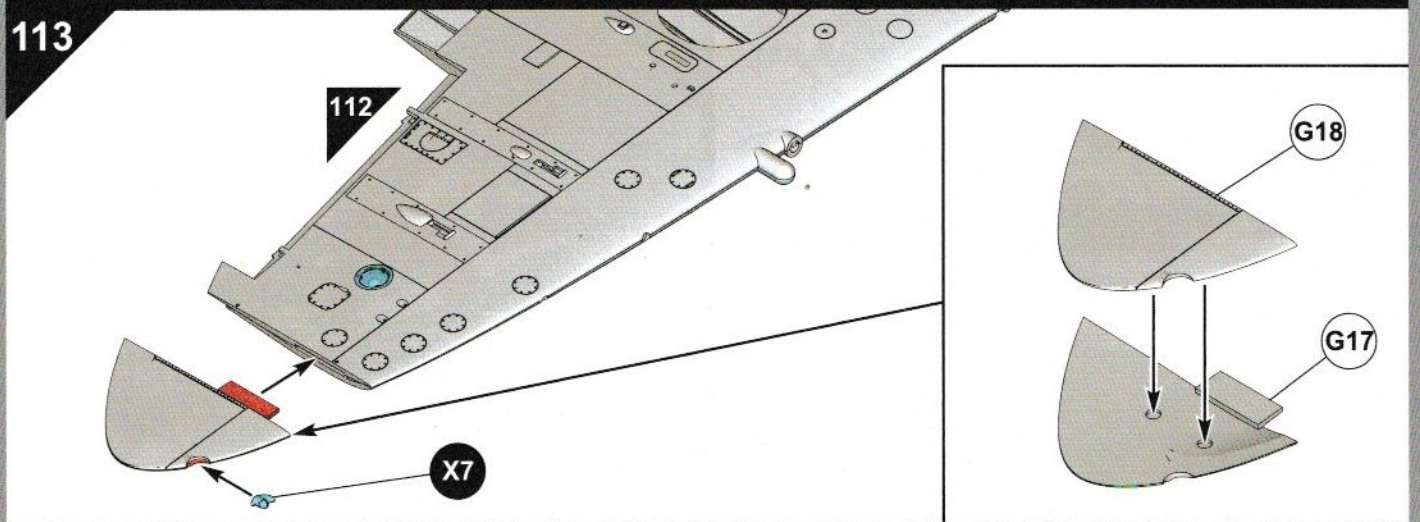
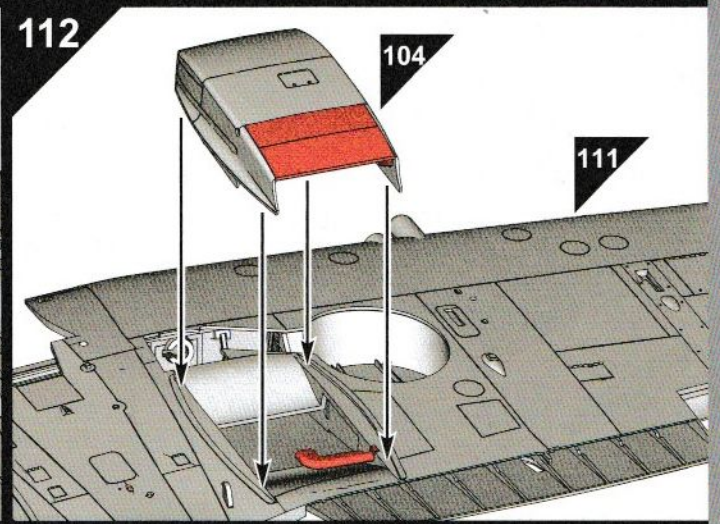
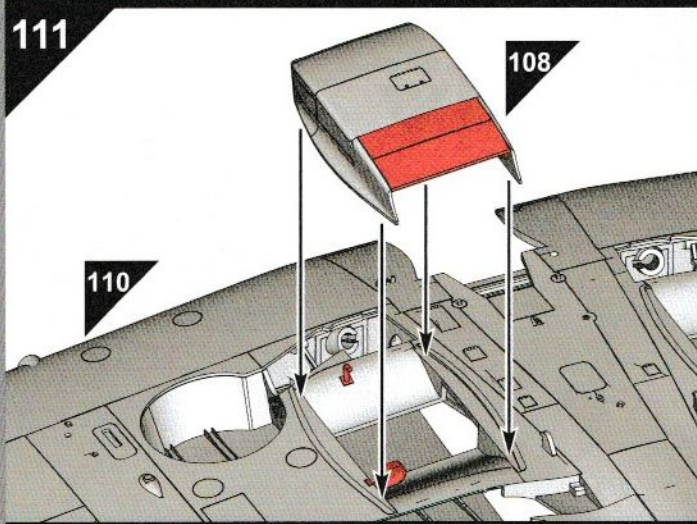
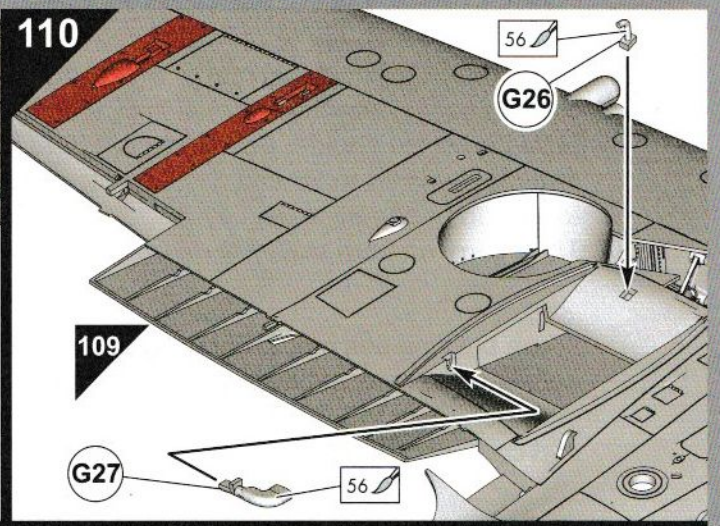
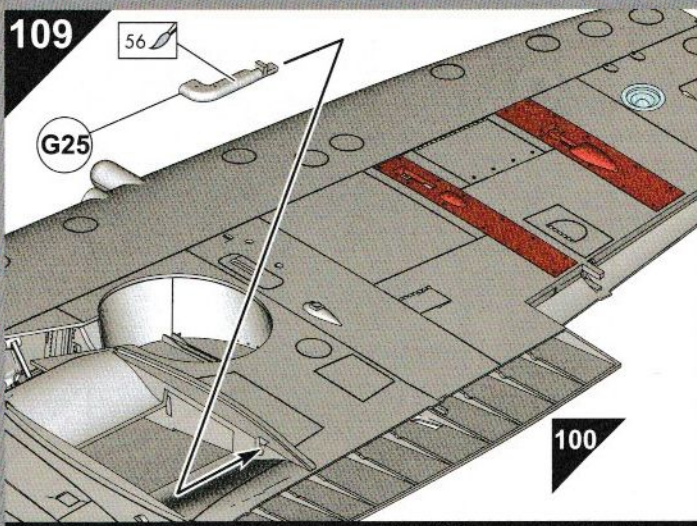



Note: When building this model with all the cowling covers attached, there is no need to build the whole engine. Follow steps 115 to 135 on pages 24 to 26 and miss out steps 136 to 198 on pages 27 to 36. Then carry on from step 199 on page 36.

When building this model showing the engine detail and options of fitting engine cowlings, miss out steps 115 to 135 on pages 24 to 26 and carry on from step 136 on page 27.

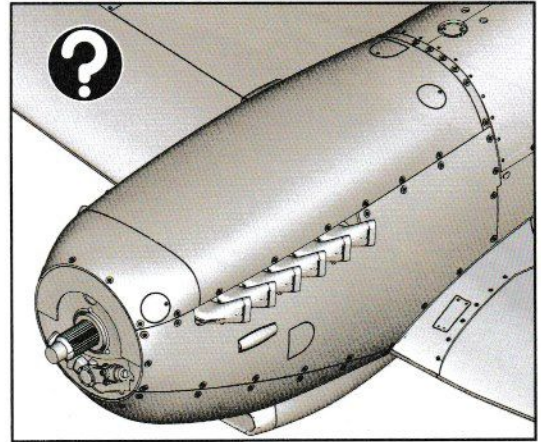

115

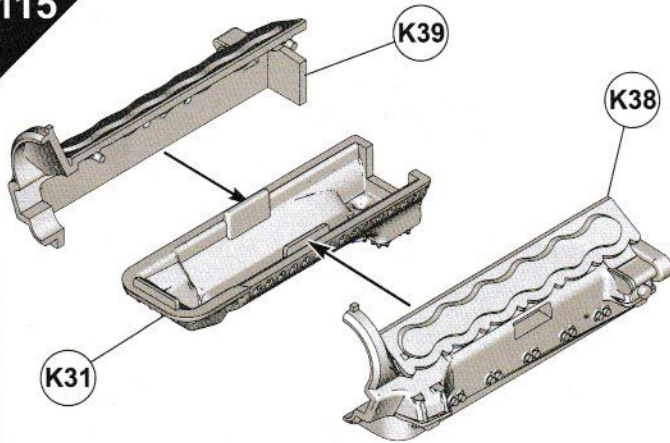

116

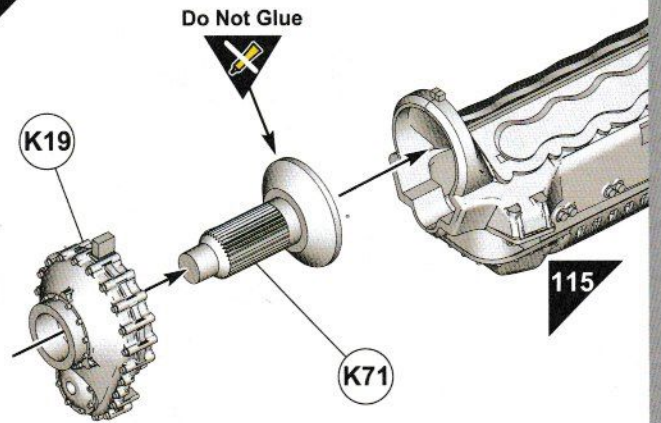

117

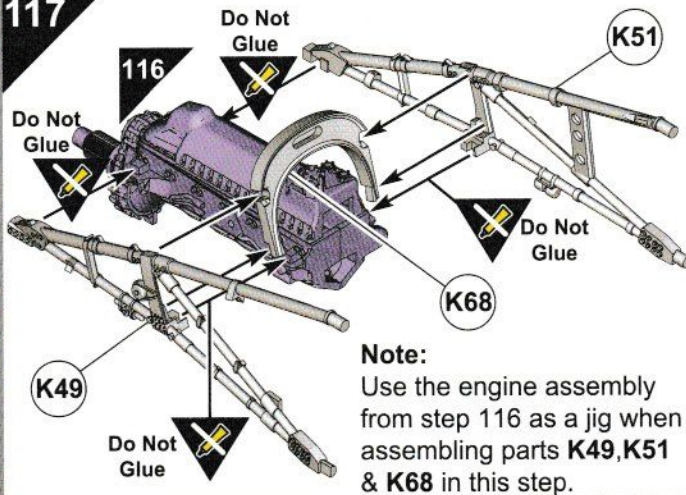

Note: Use the engine assembly from step 116 as a jig when assembling parts K49, K51 & K68 in this step.

118

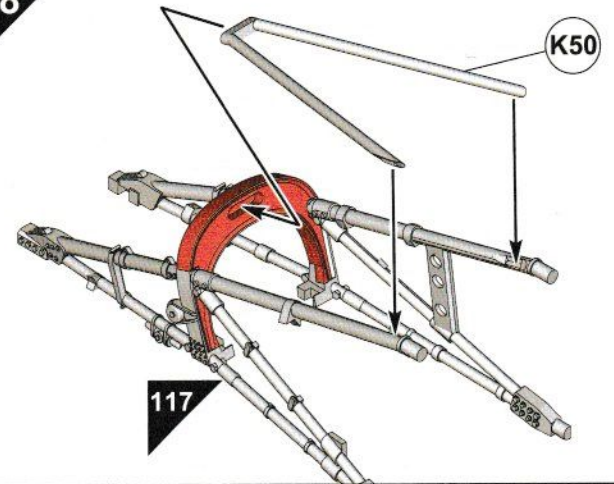

119

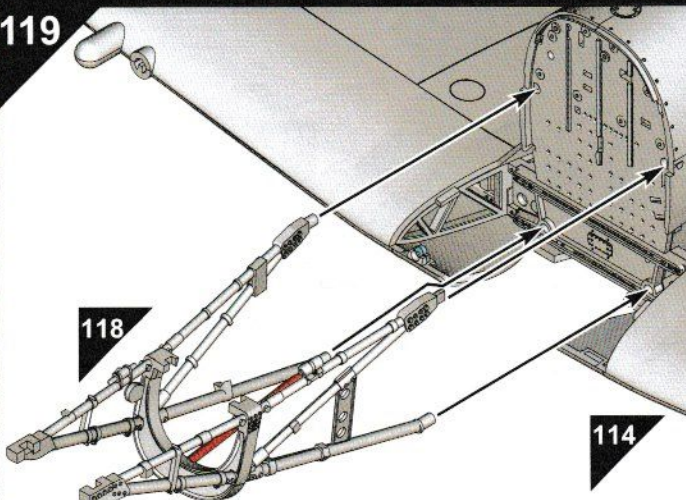

120

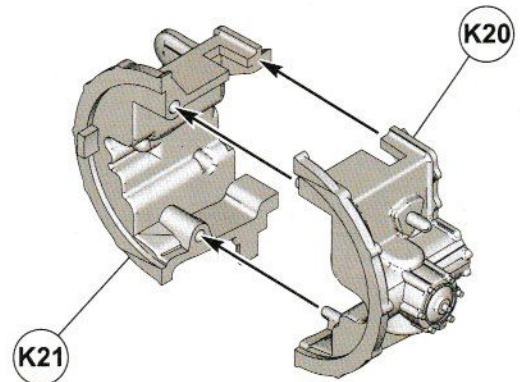

121

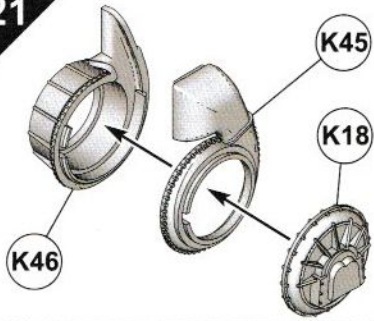

123

Note: cut off the section shown in green to allow the cowling assembly to be fitted from the front. See Step 135 on Page 26

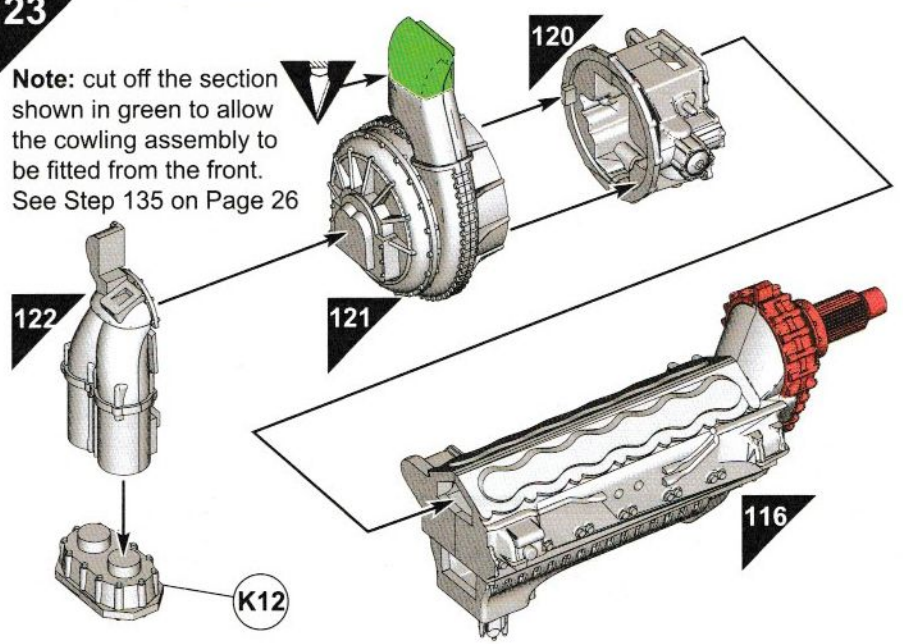

122

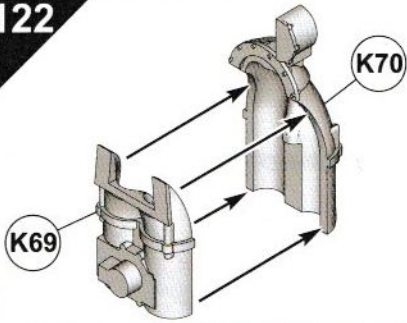

124

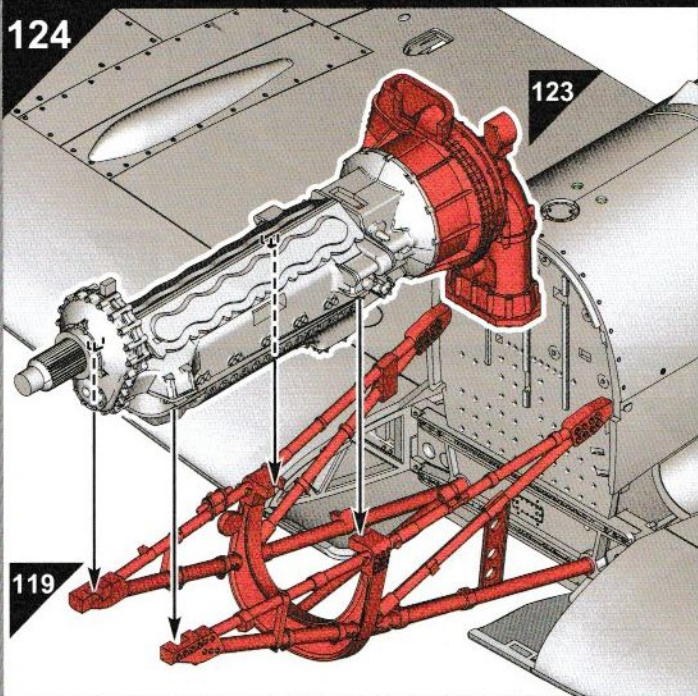

125

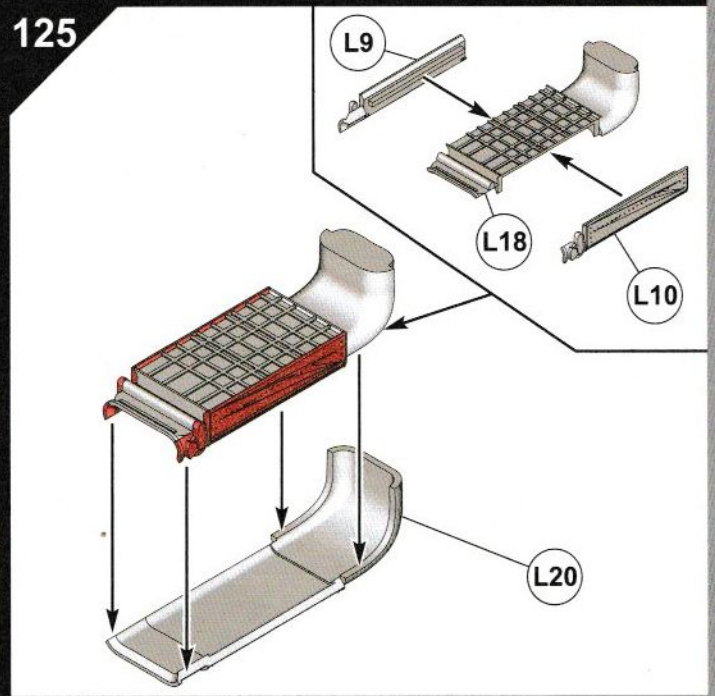

126

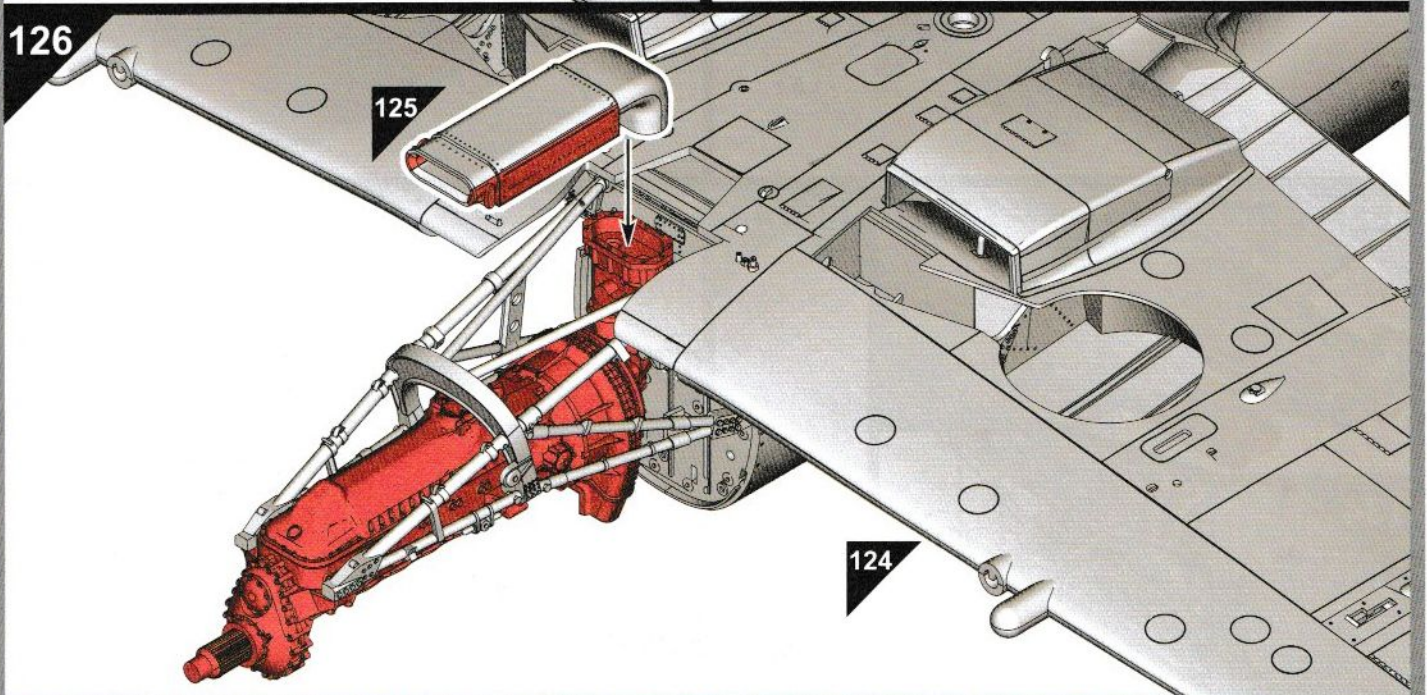

127

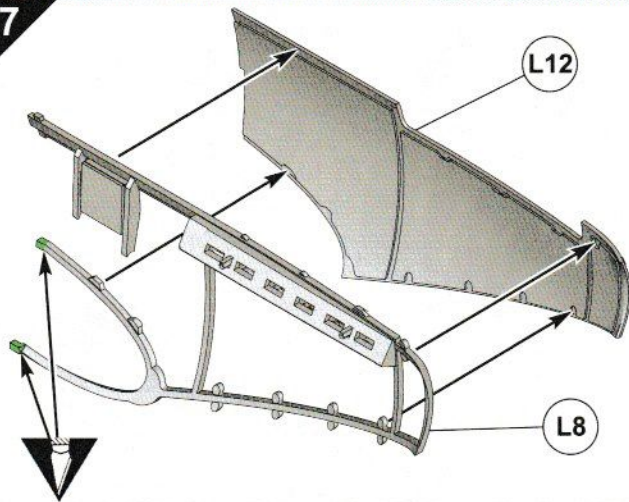

128

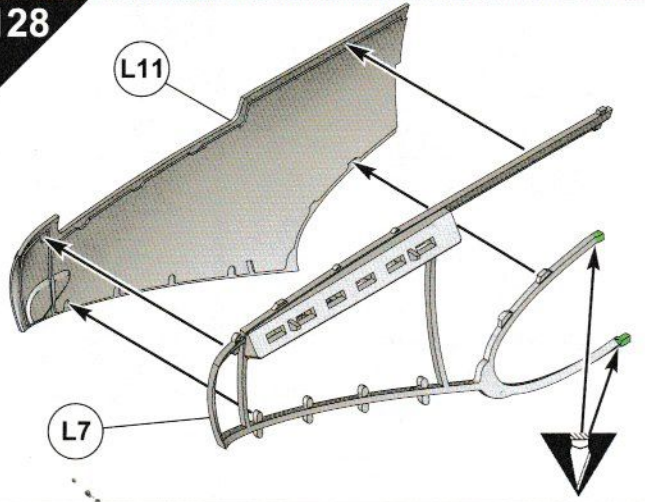

129

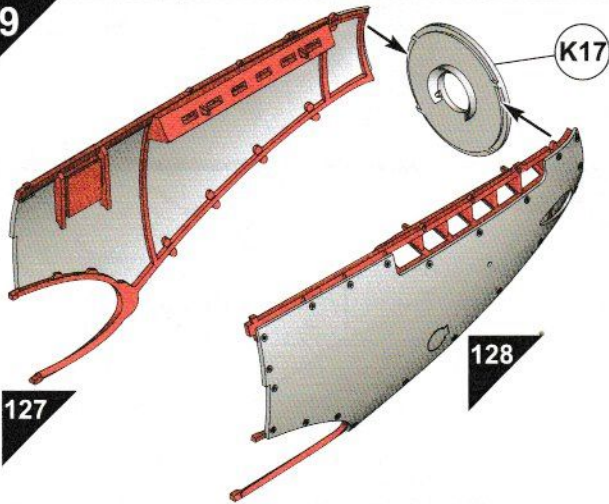

130

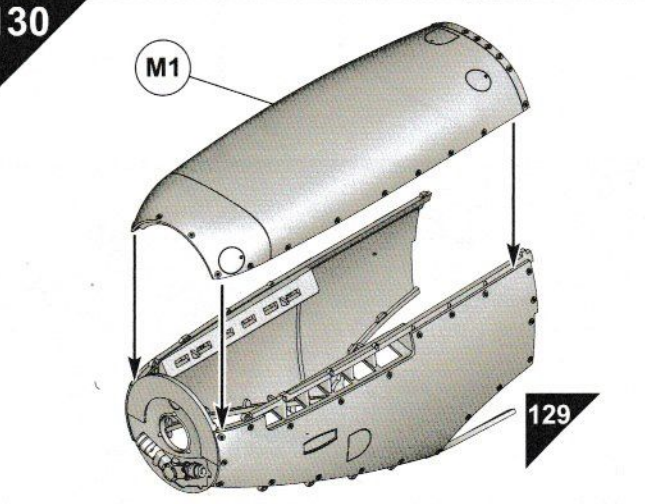

131

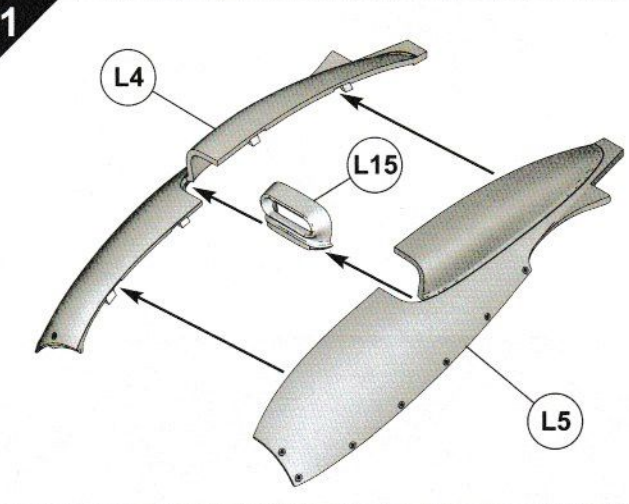

132

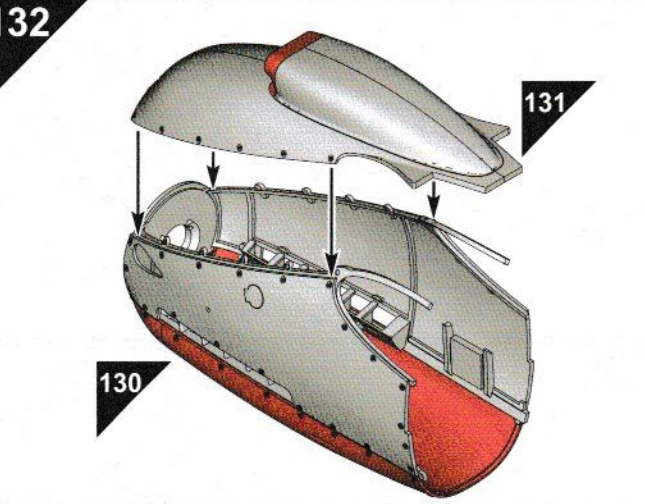

133

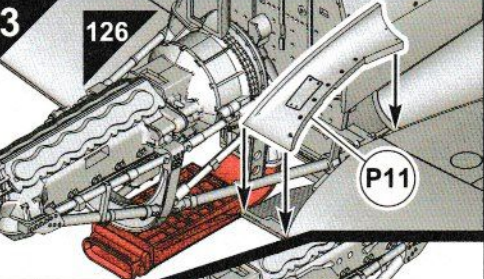

135

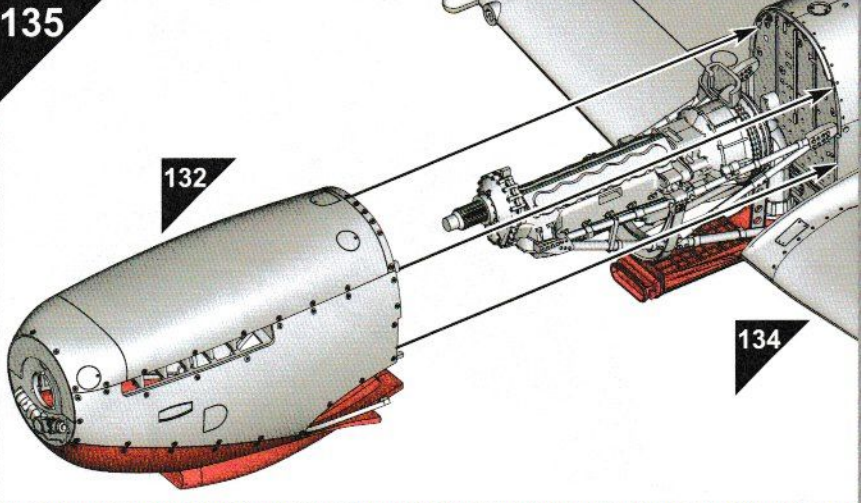

134

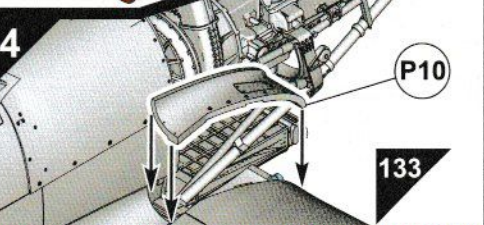

136

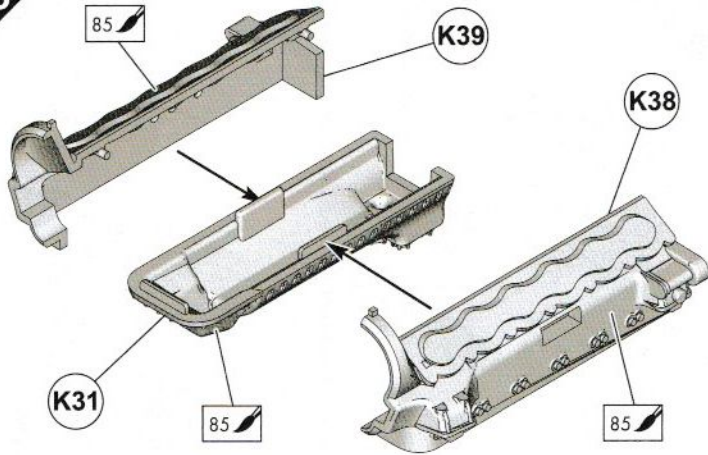

137

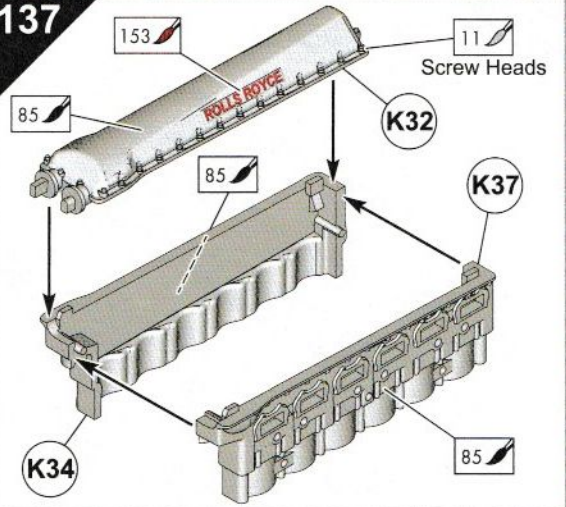

138

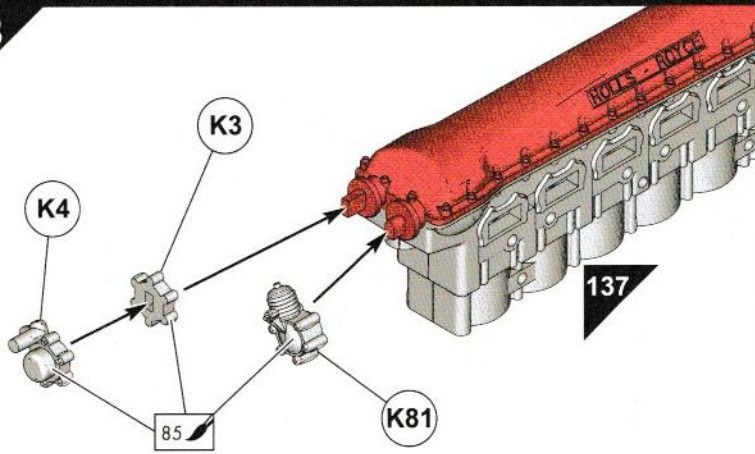

139

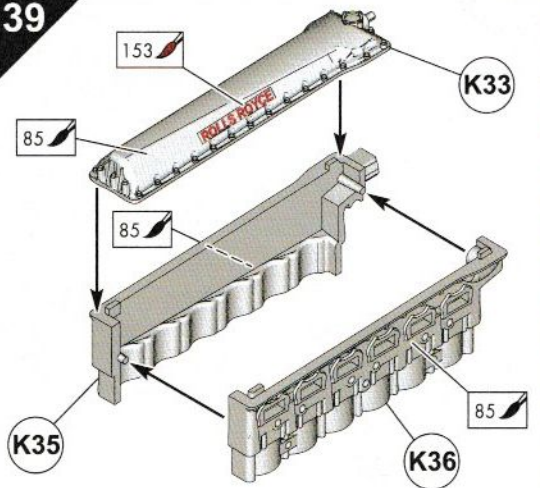

140

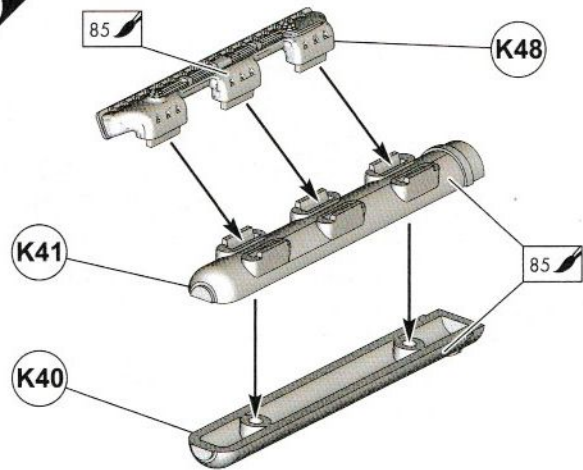

141

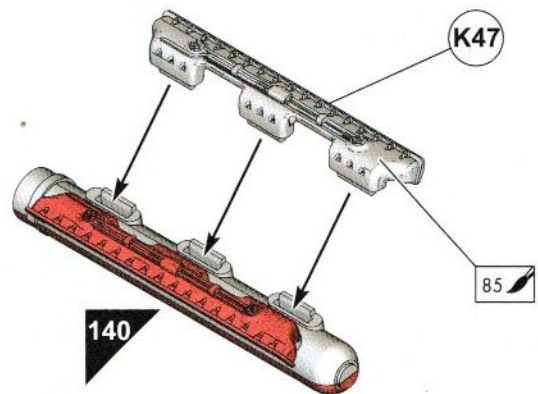

142

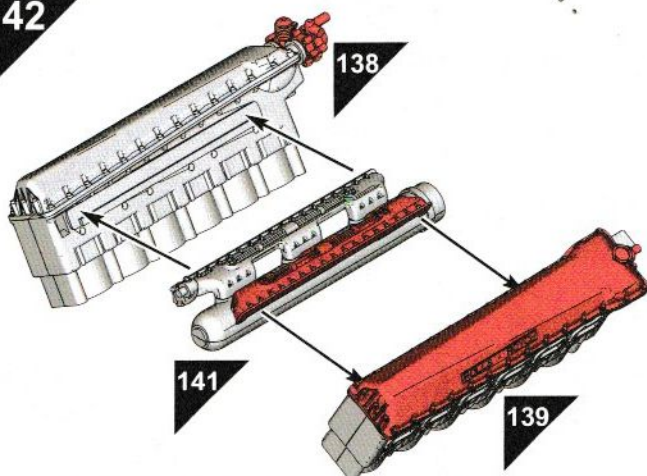

143

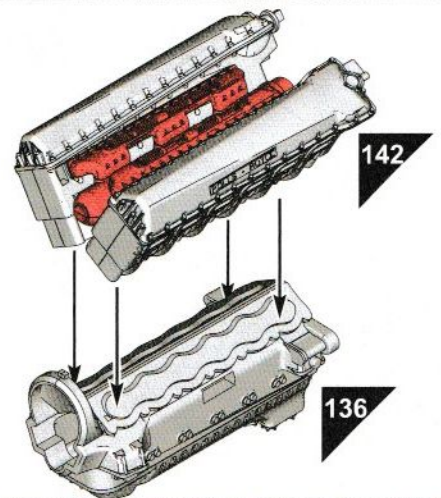

144

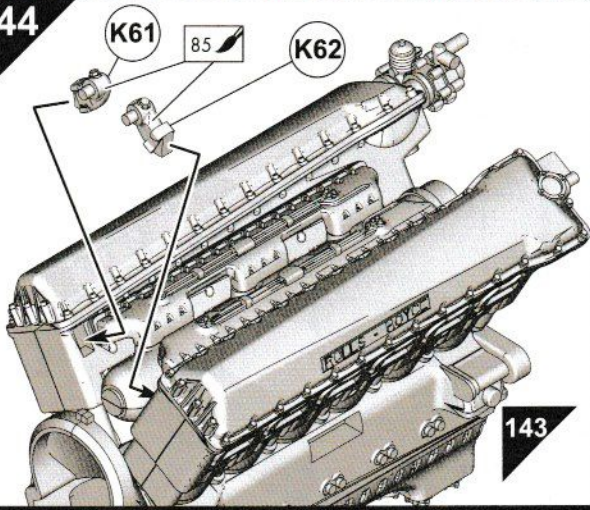

145

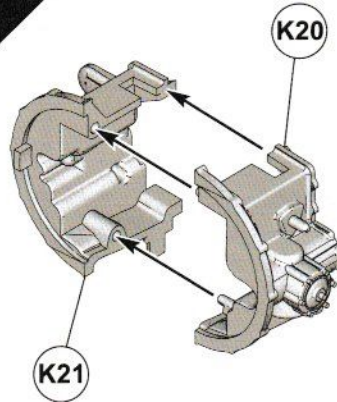

146

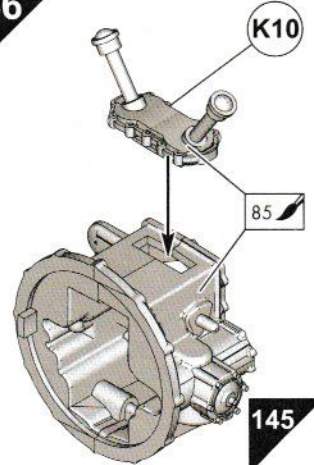

147

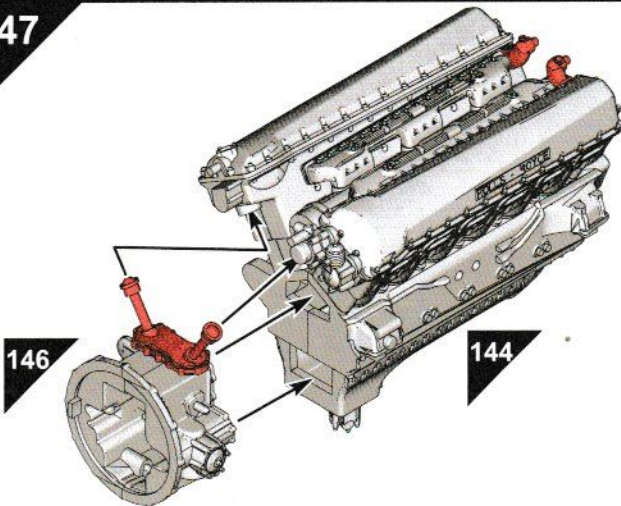

148

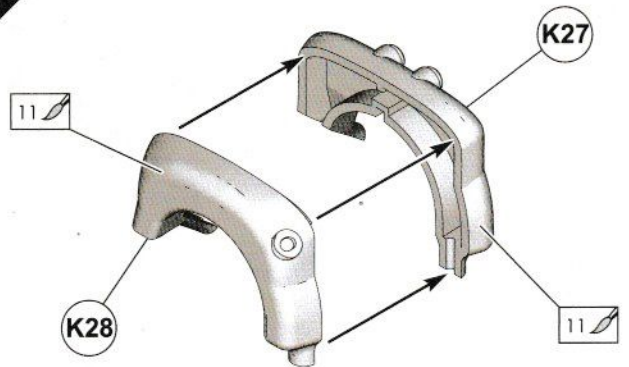

149

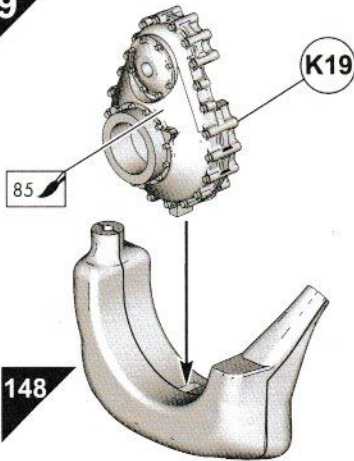

150

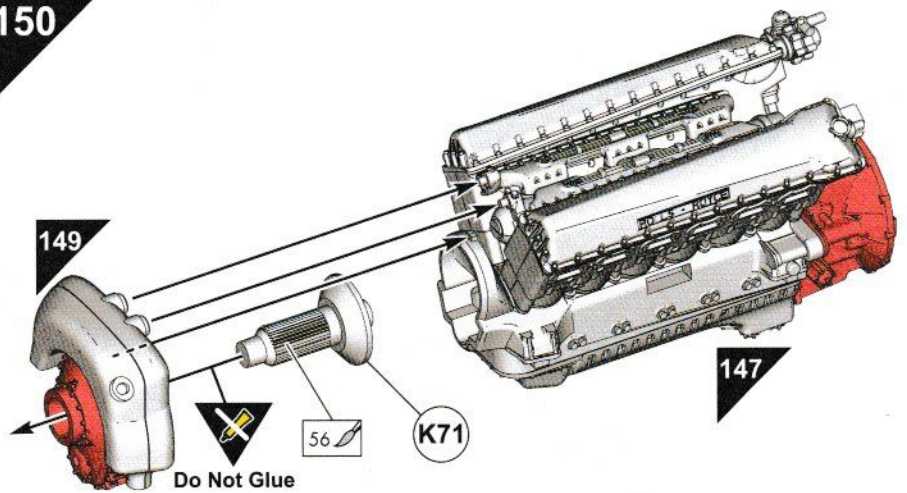

151

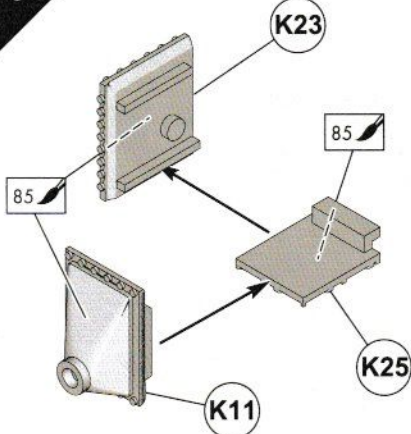

152

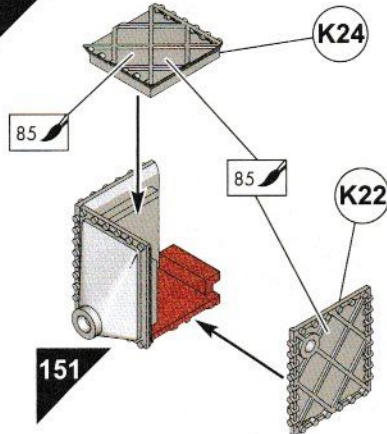

153



154

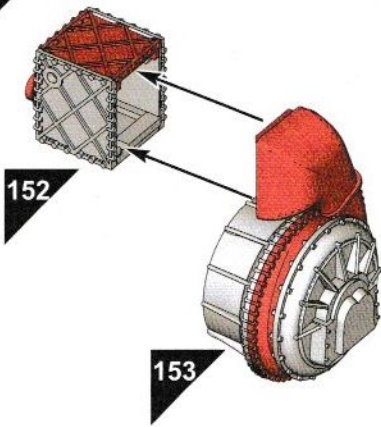

155

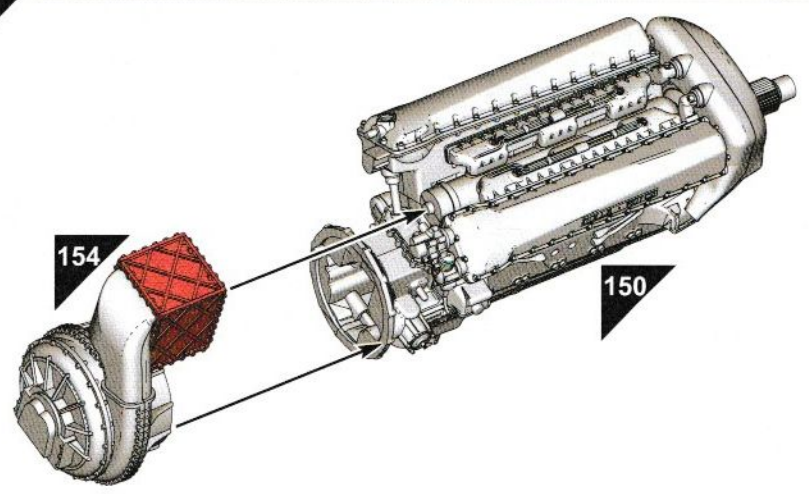

156

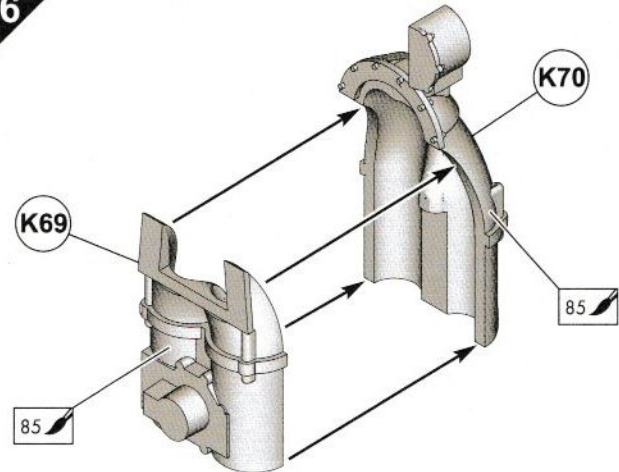

157

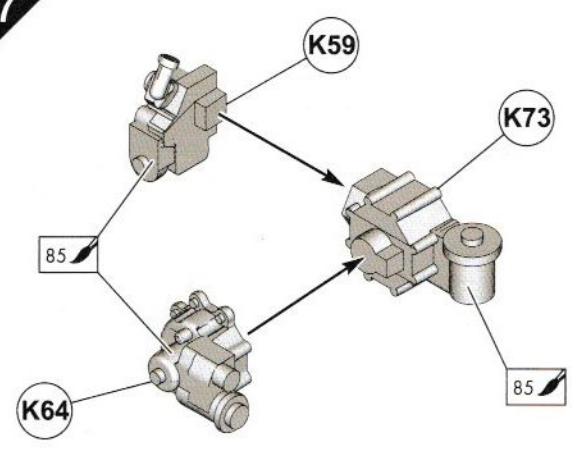

158

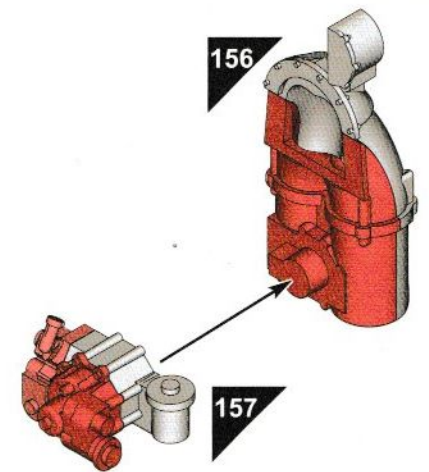

159

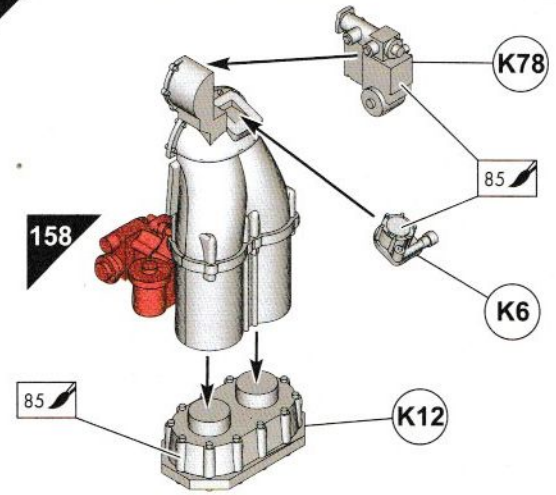

160

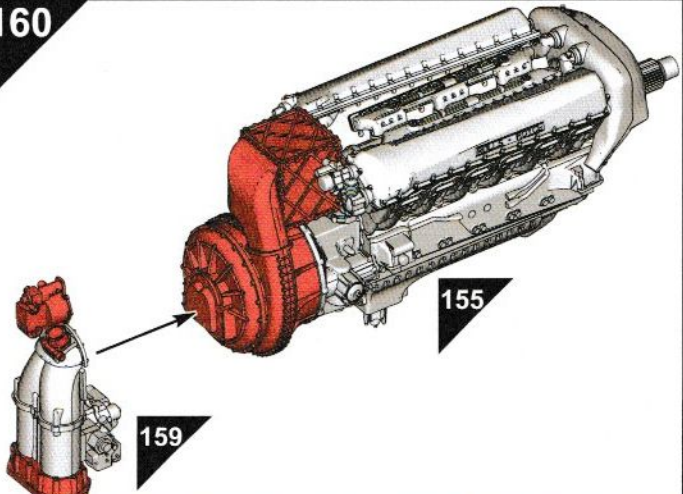

161

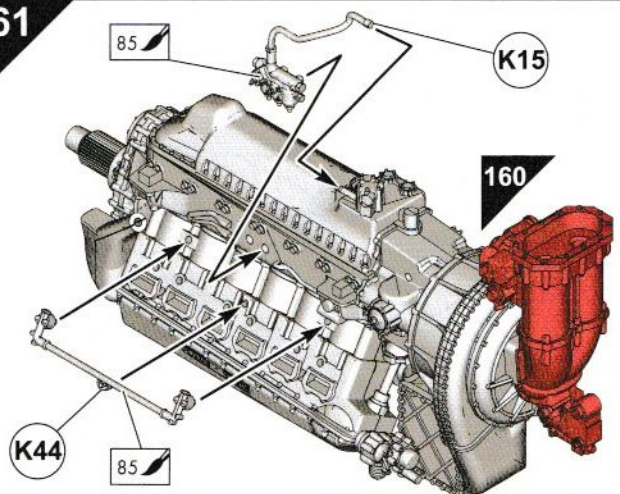

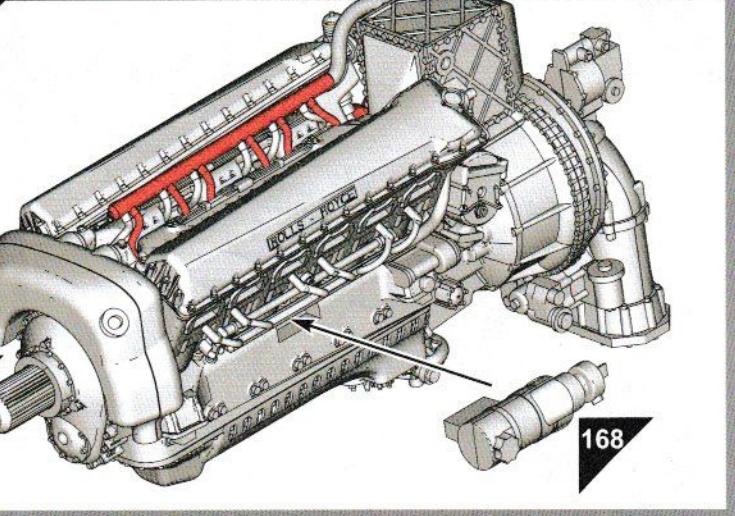
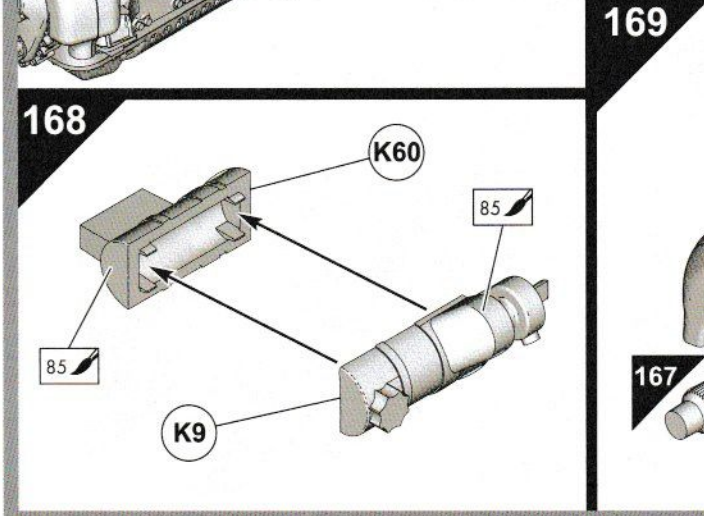
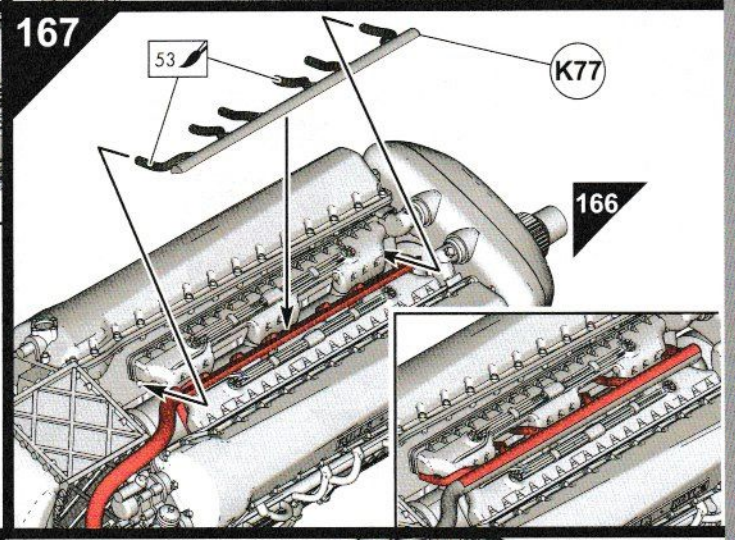
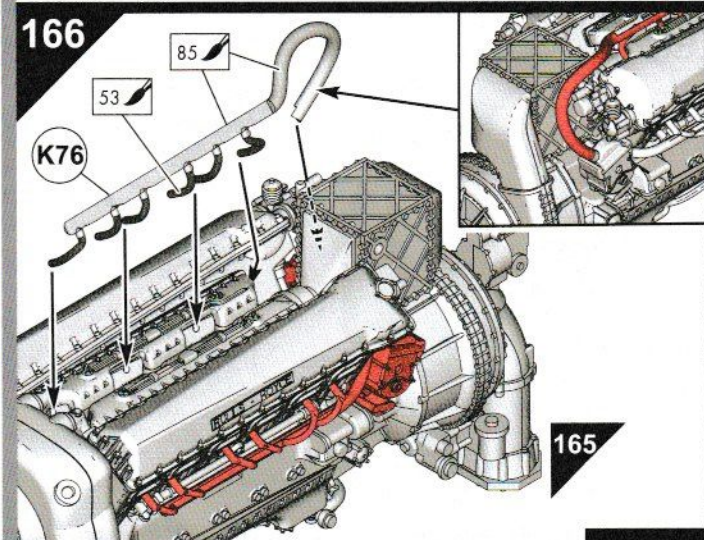
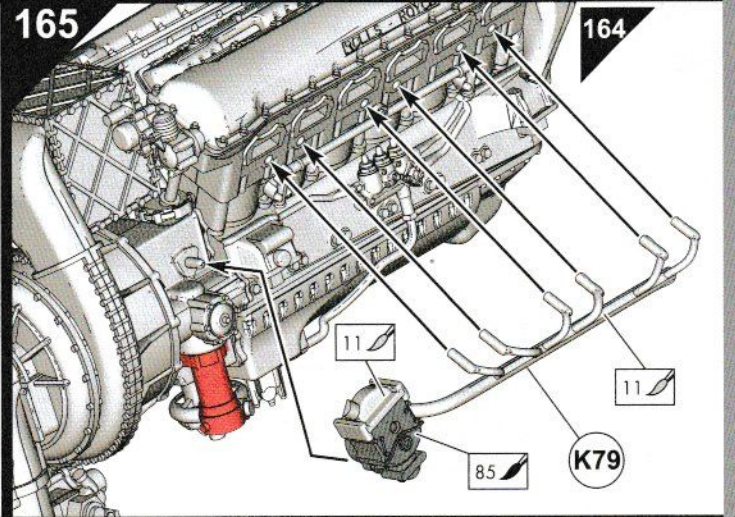
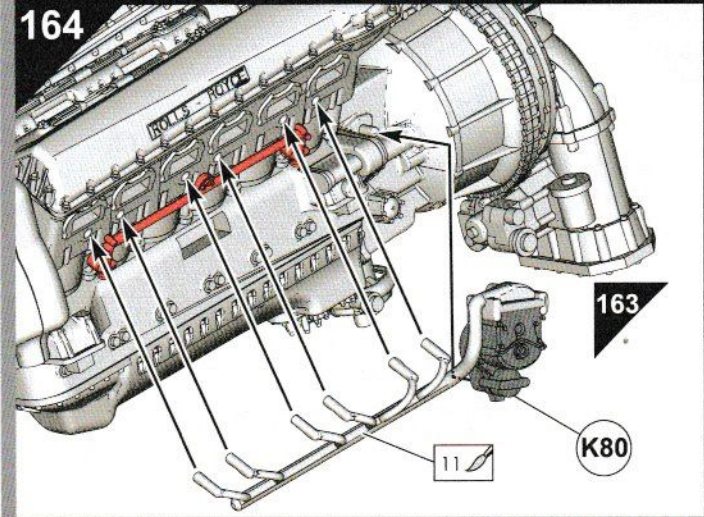
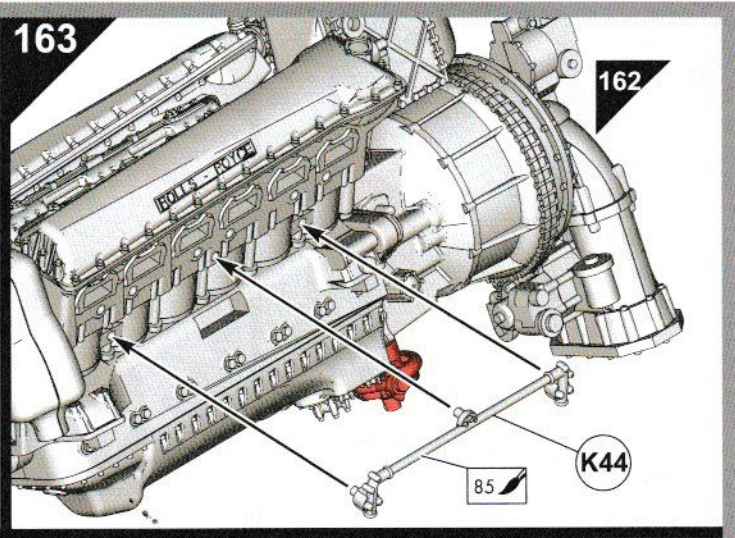
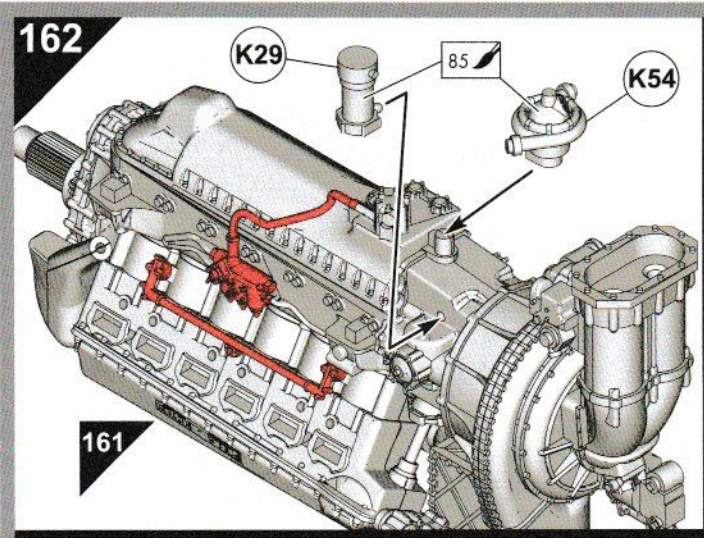

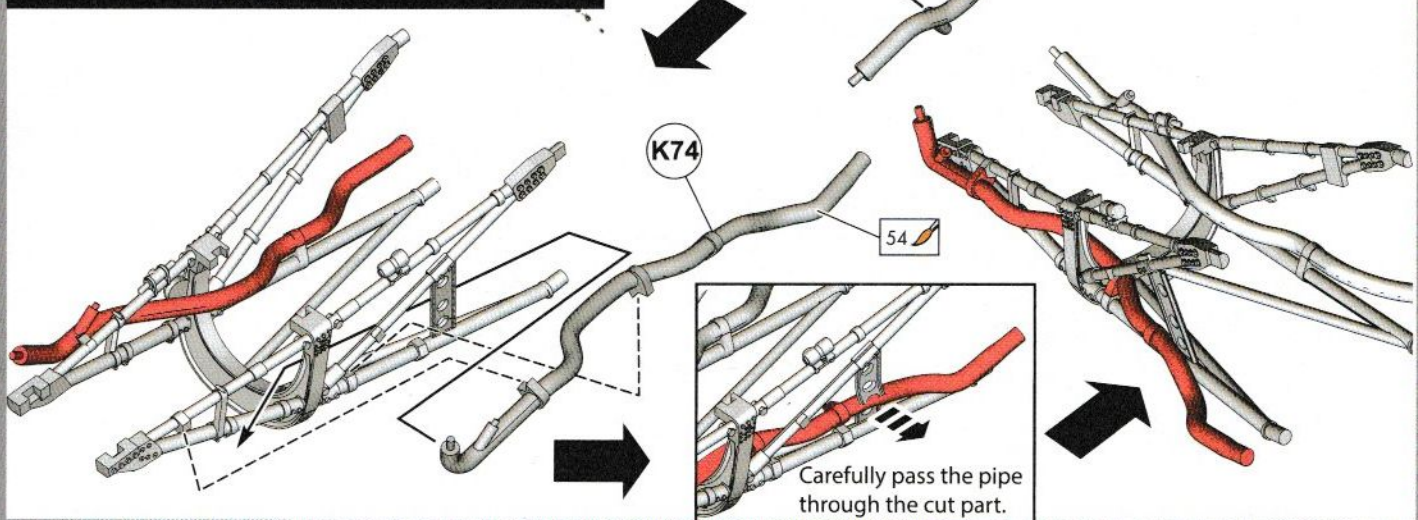
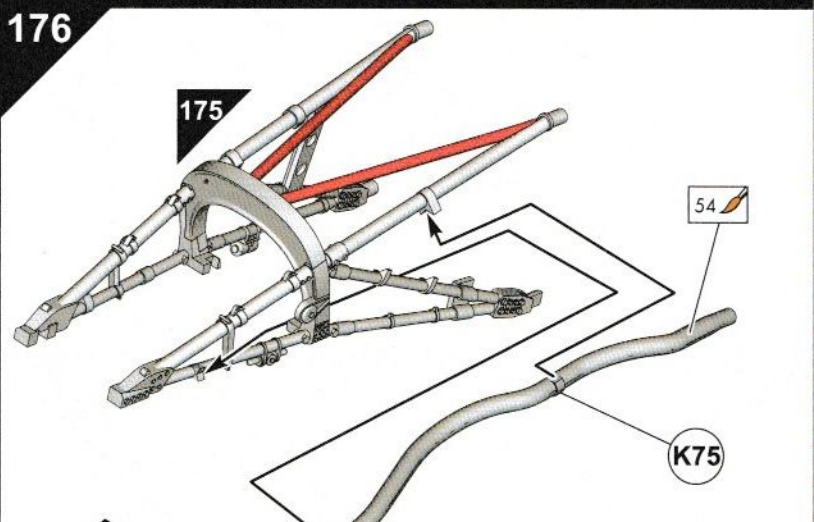
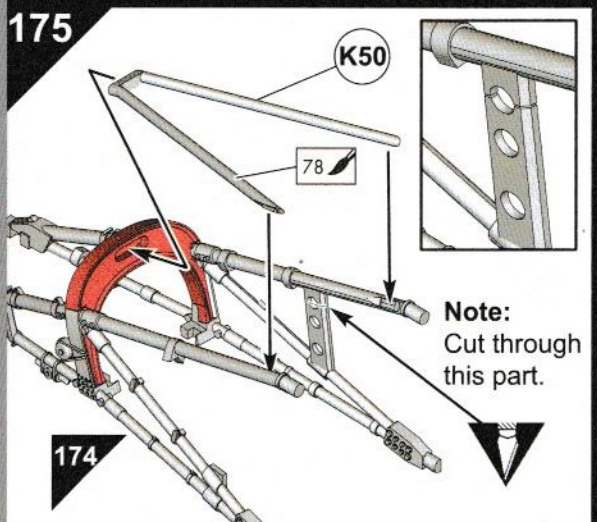
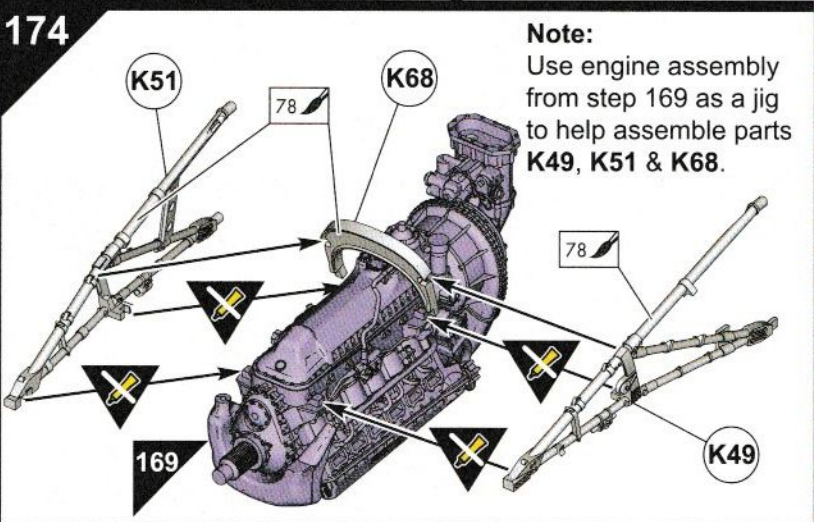
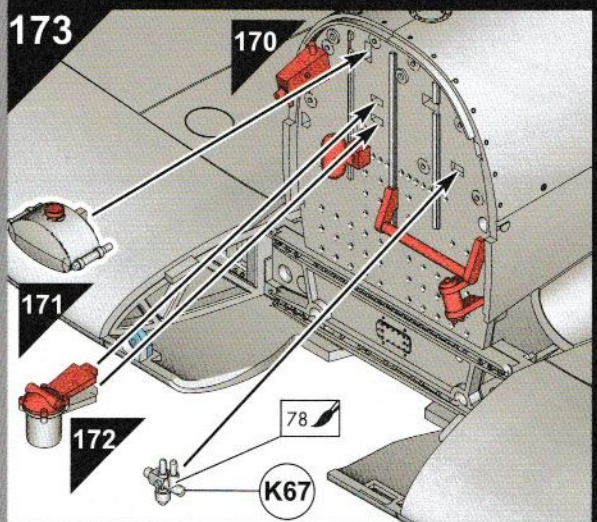
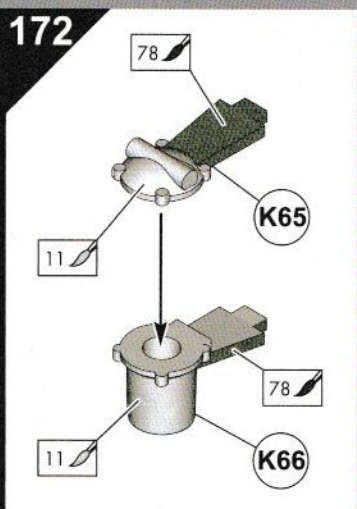
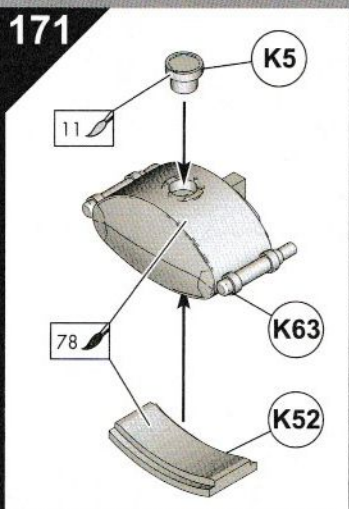
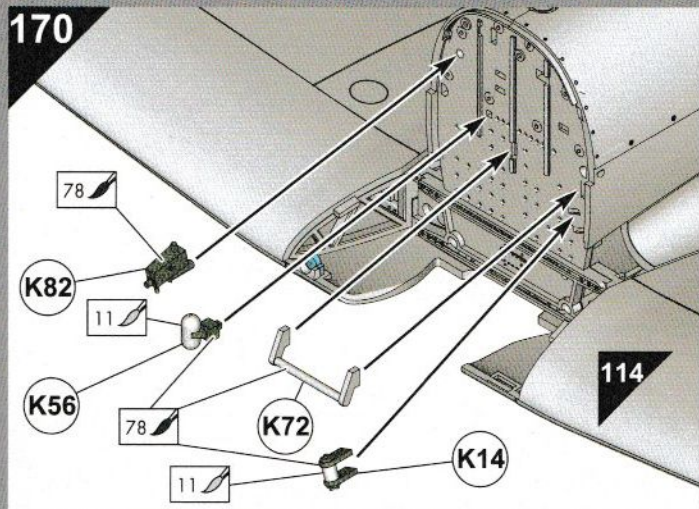

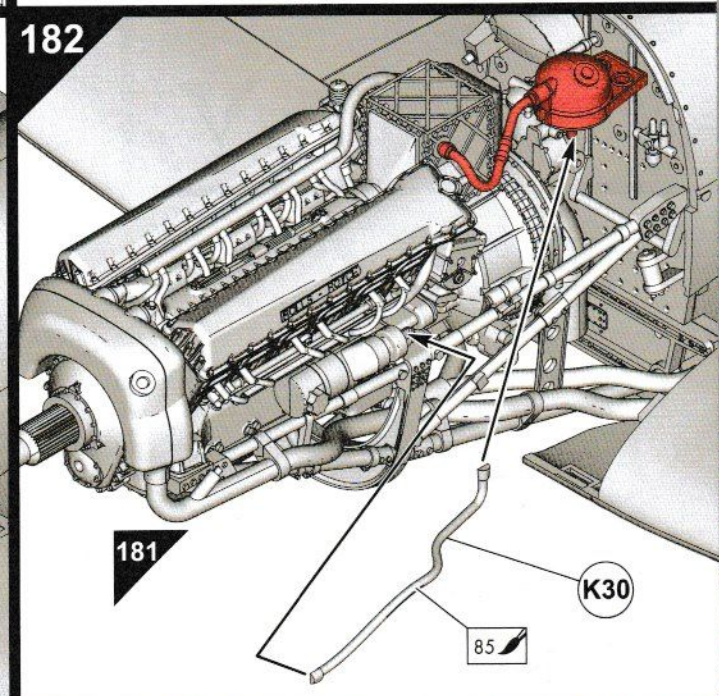
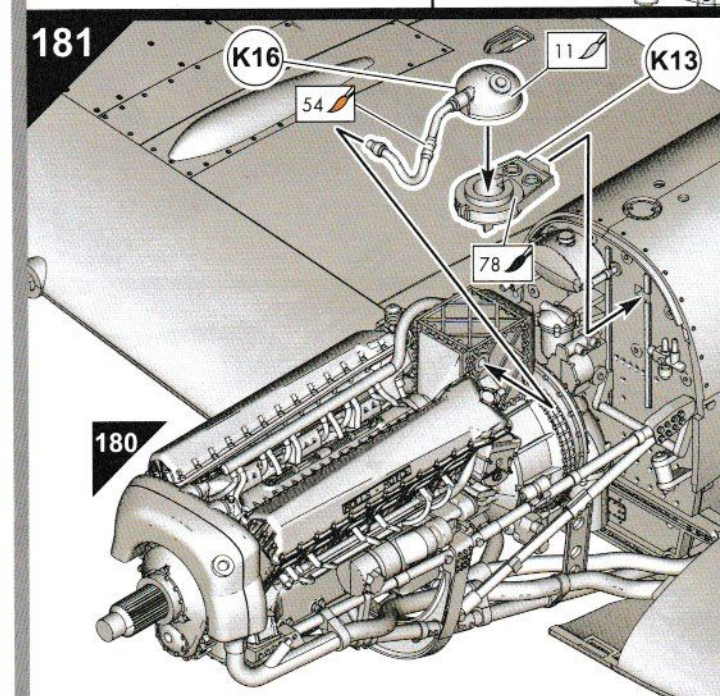
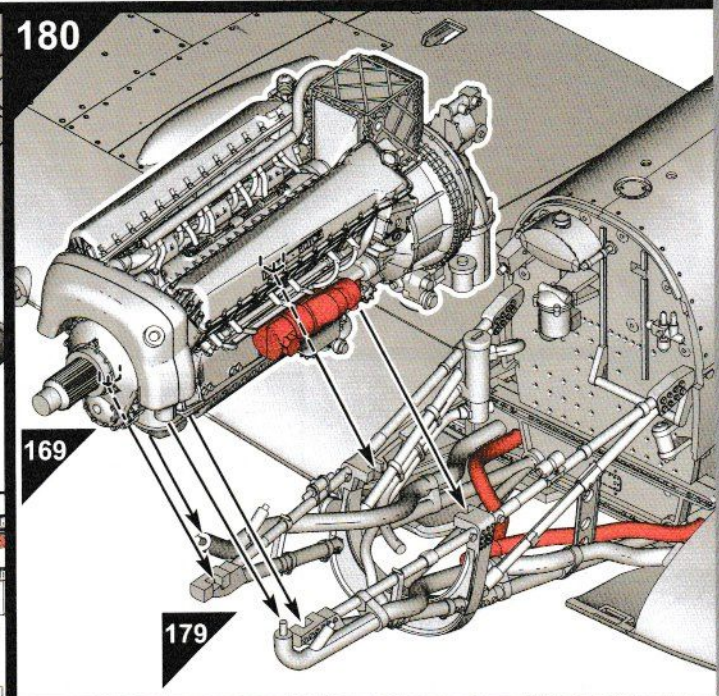
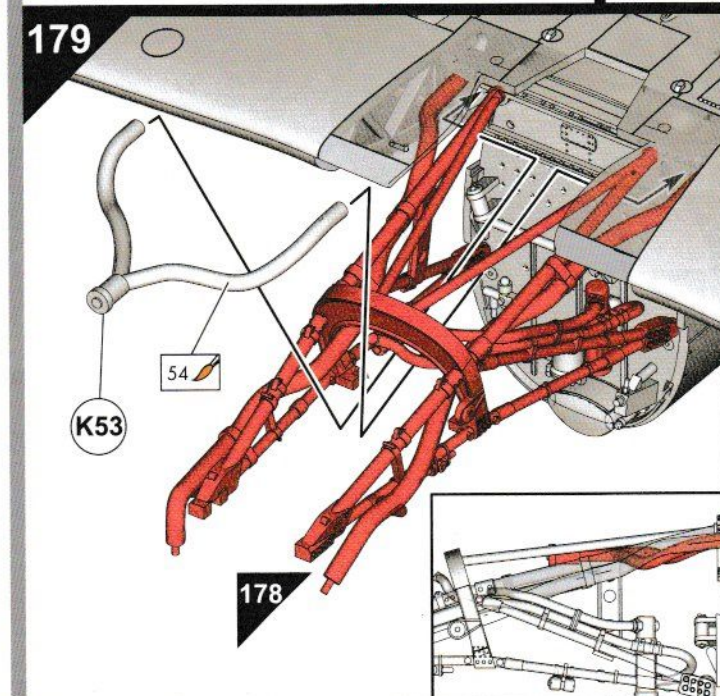
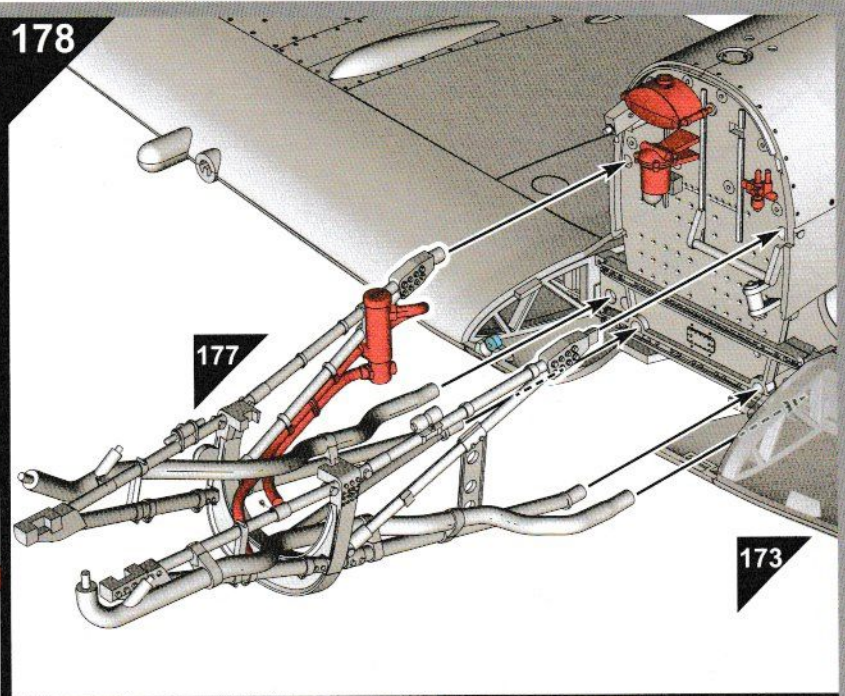
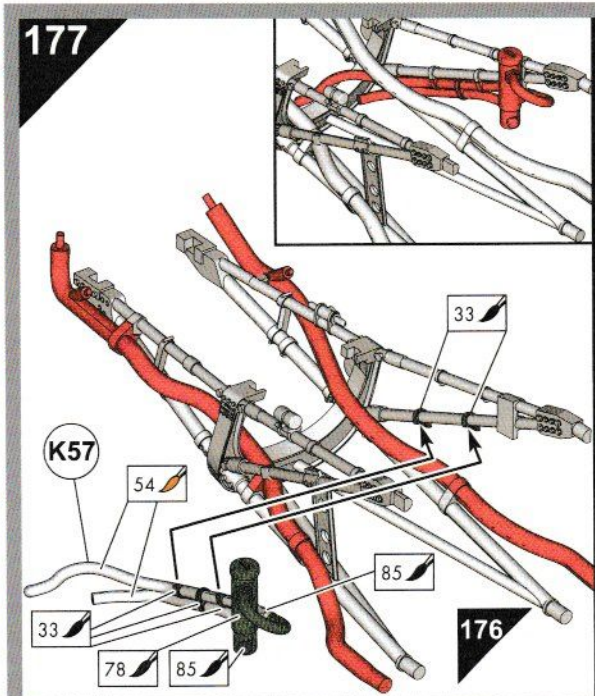

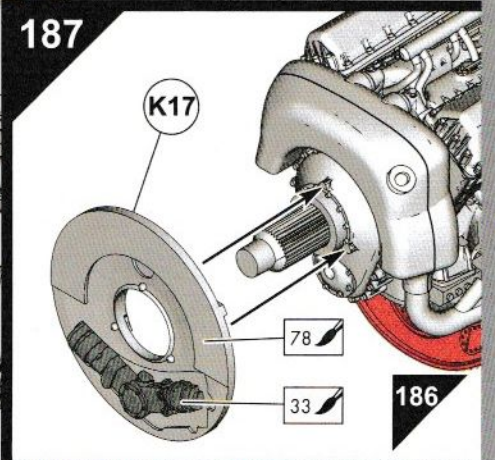
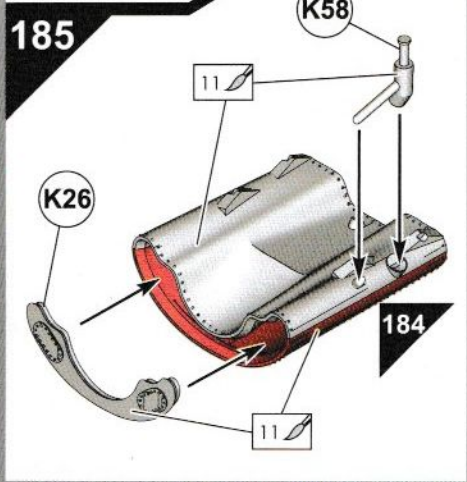
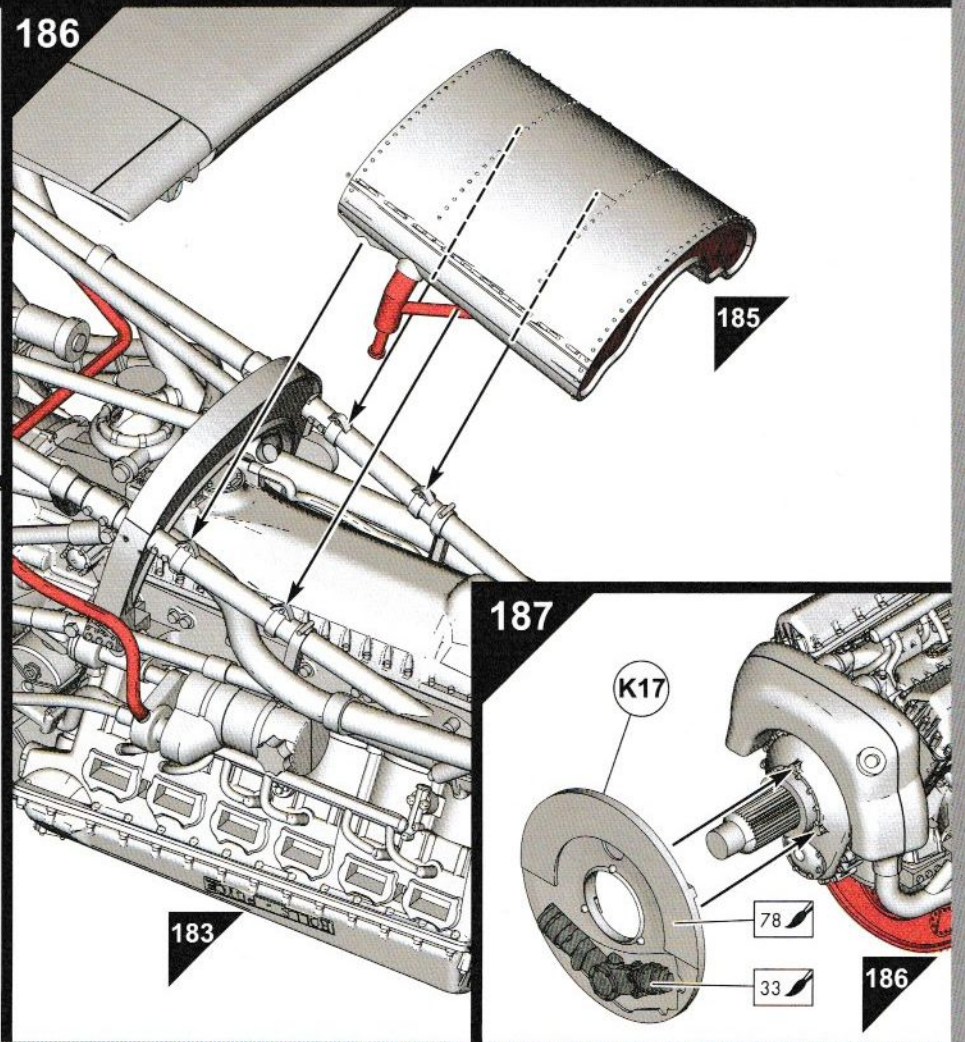
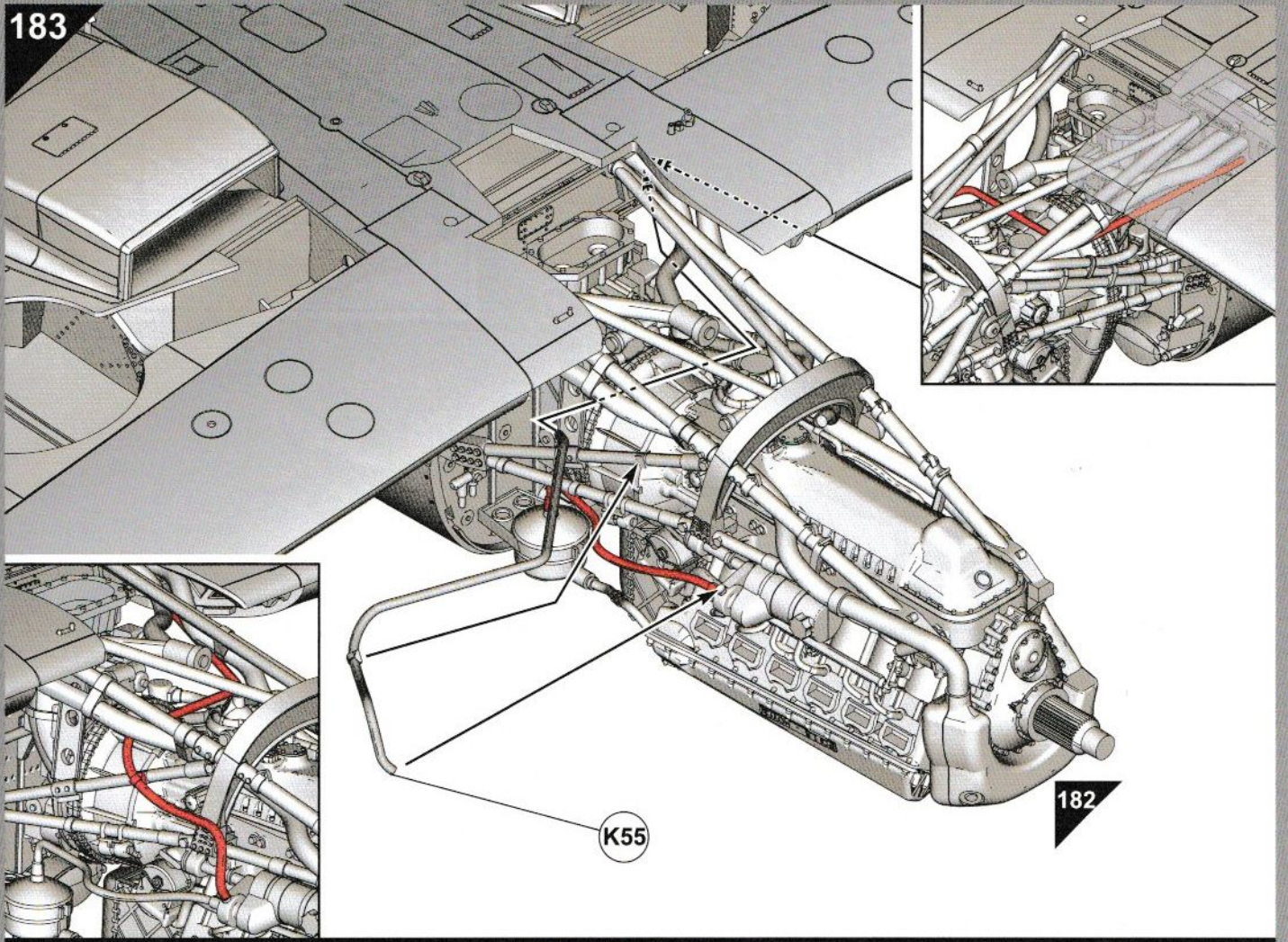

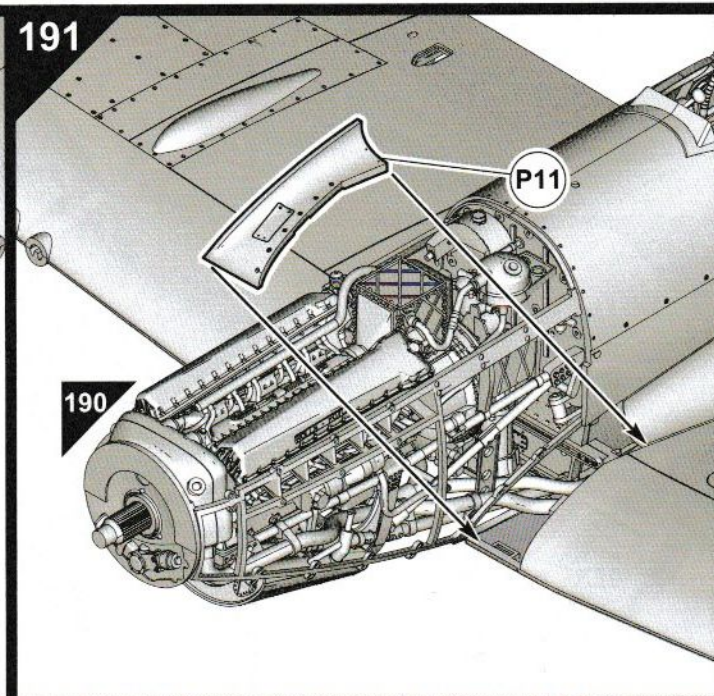
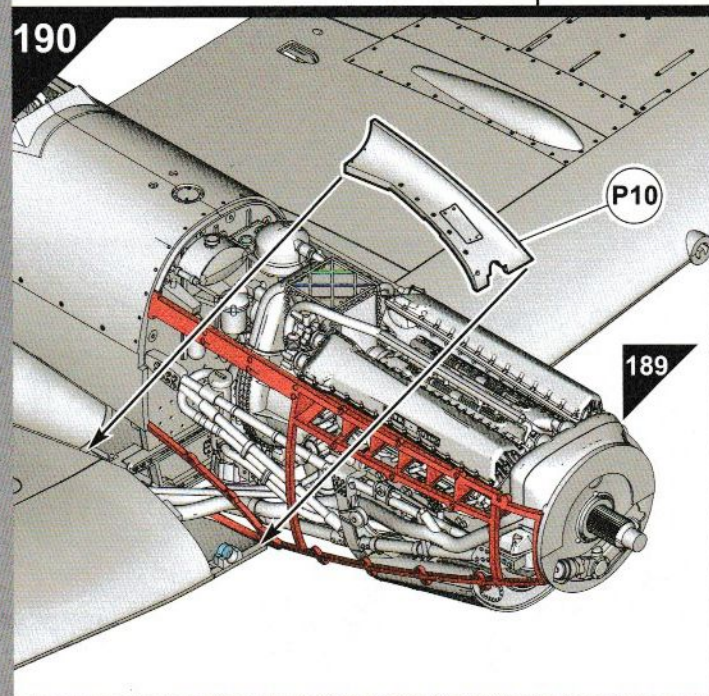
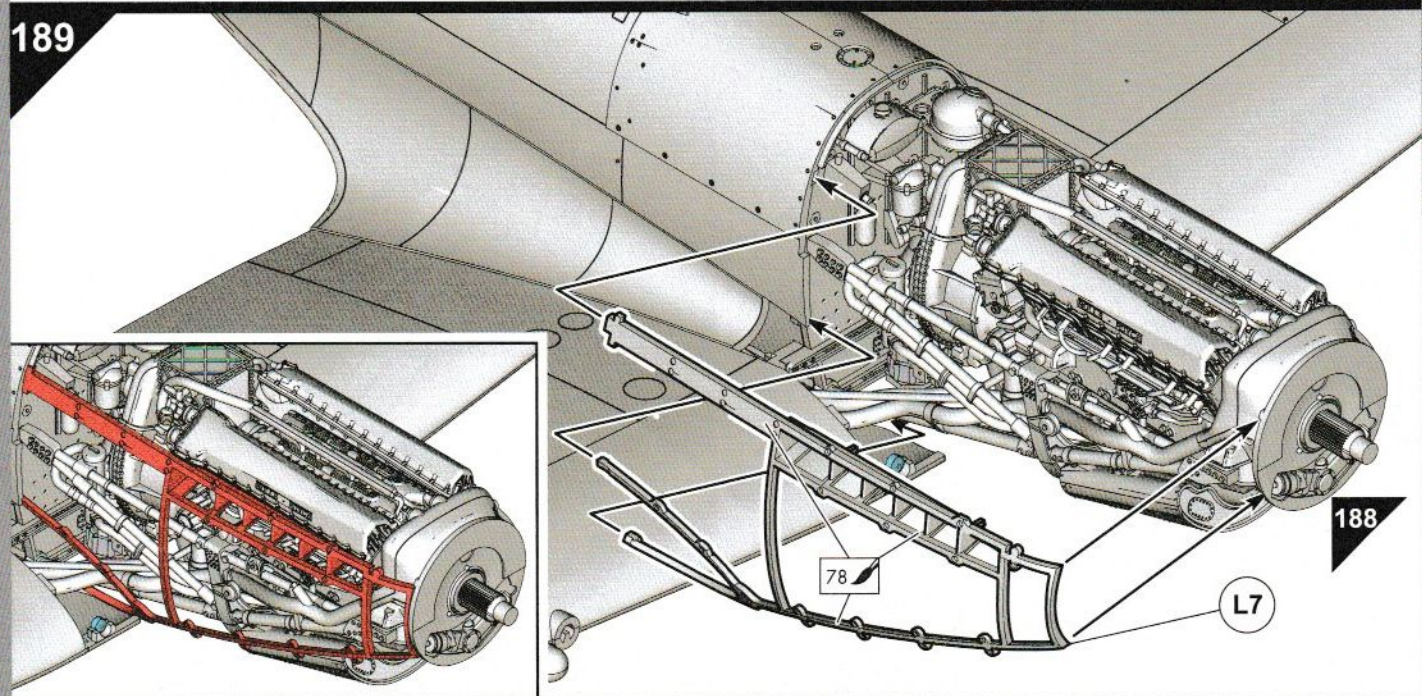
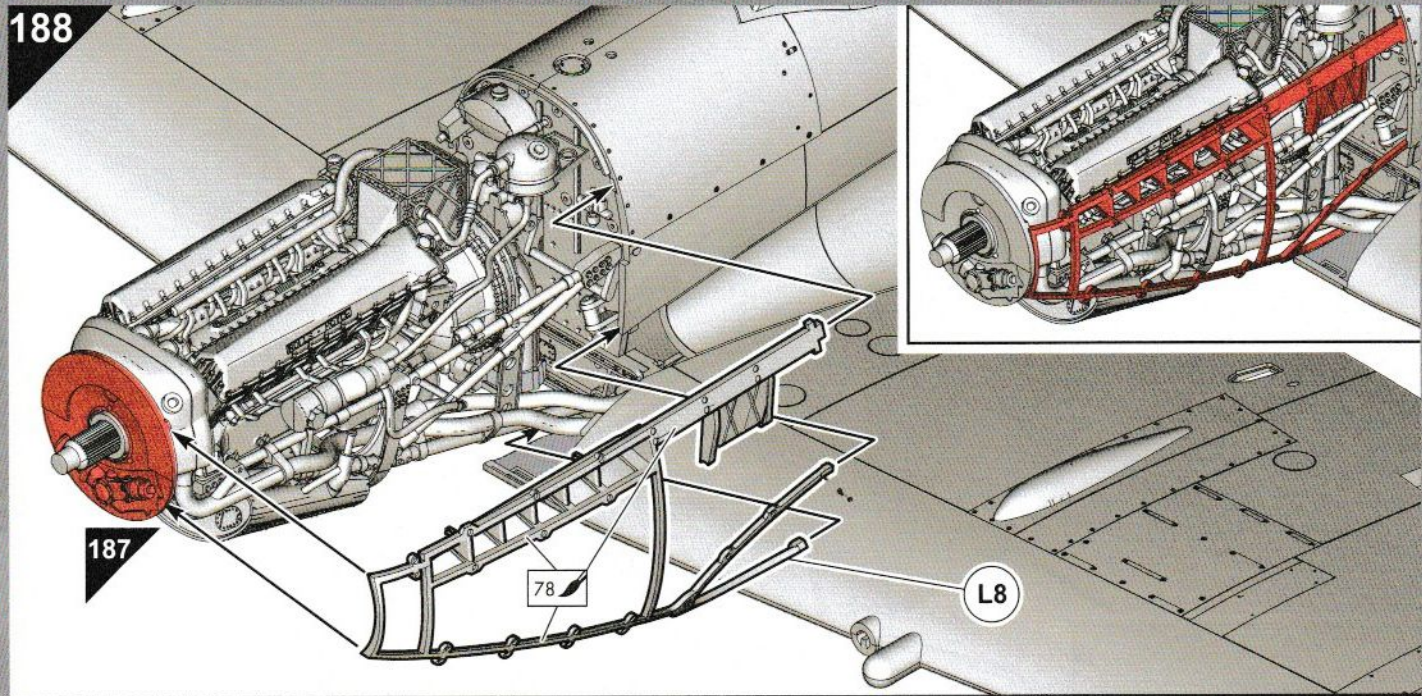

192

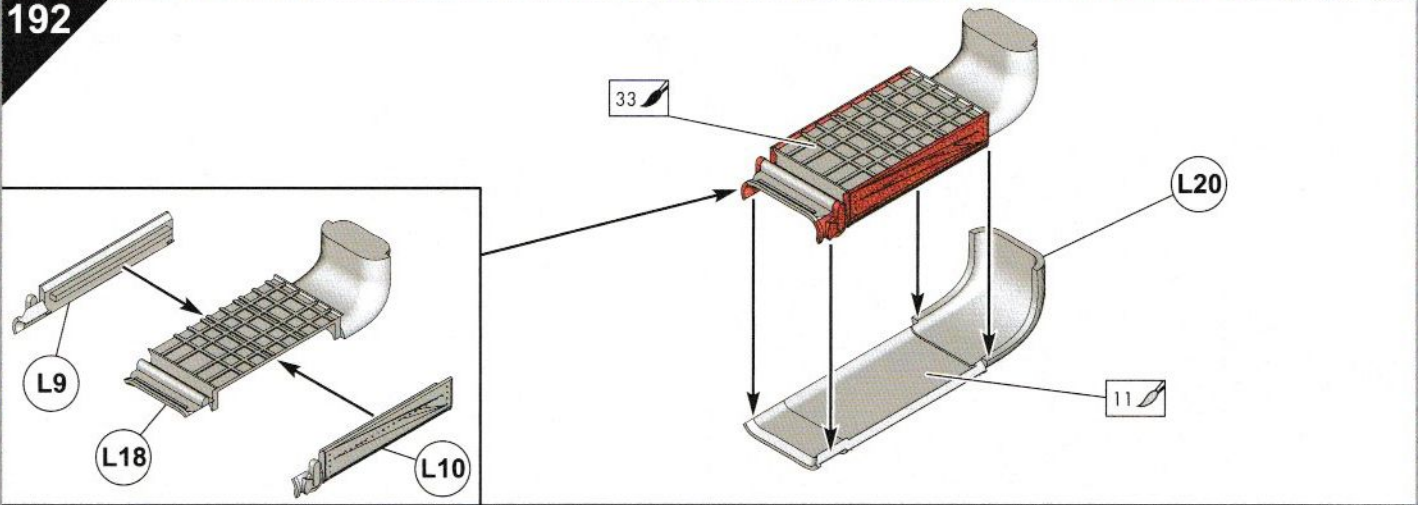

193

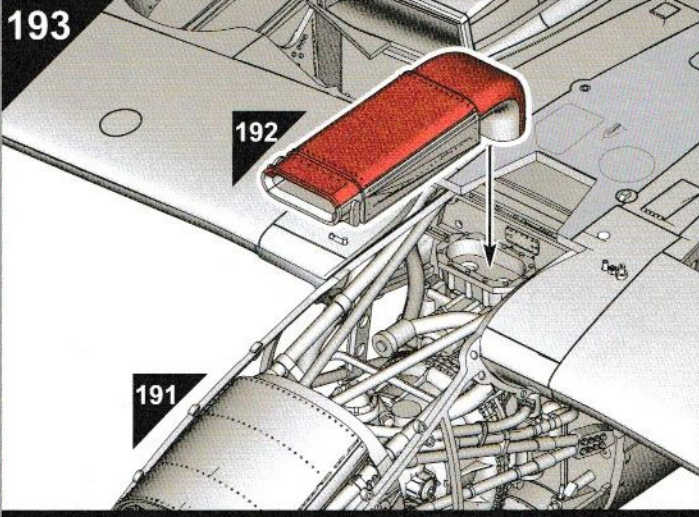

194

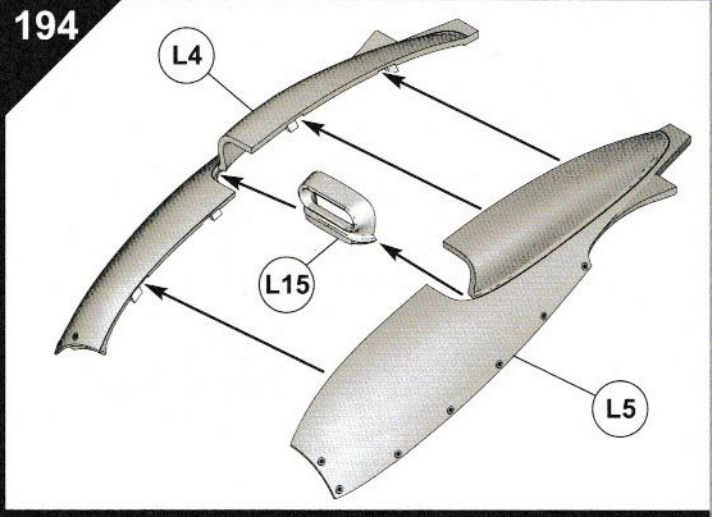

195

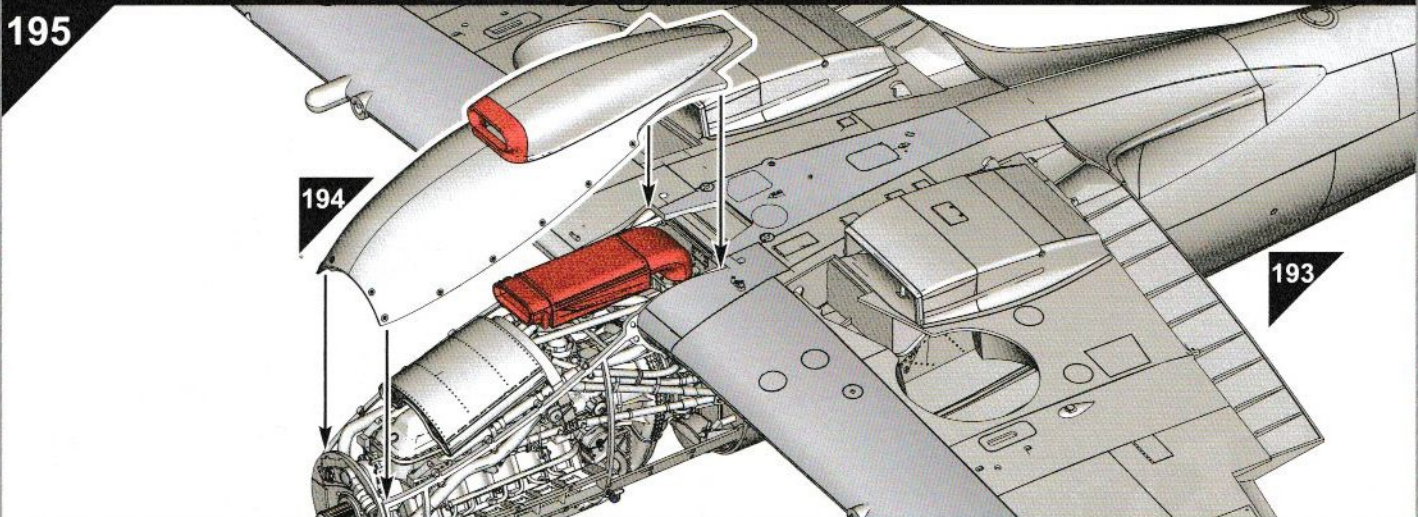

196

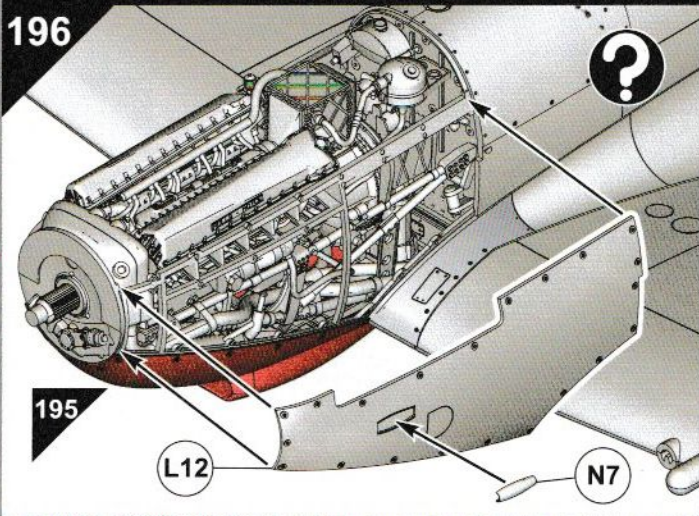

197

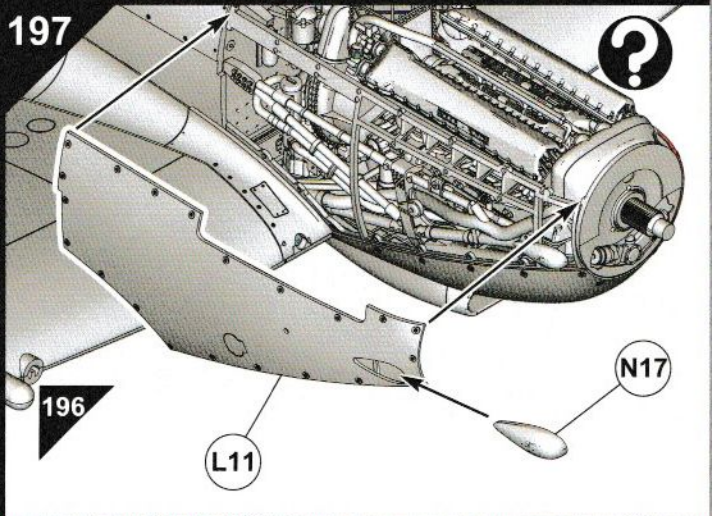

198

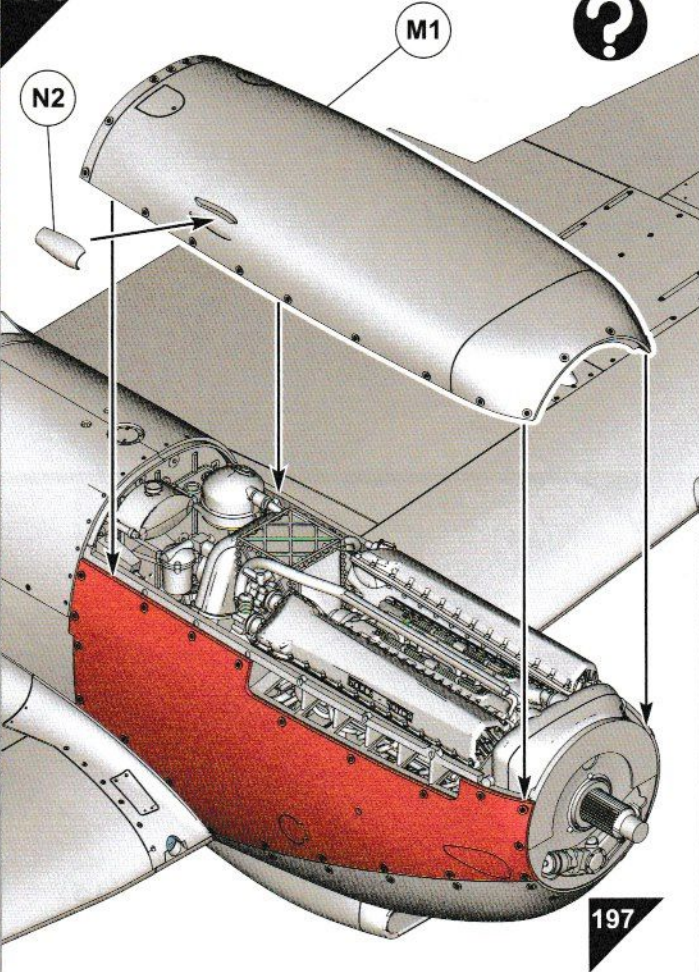

199

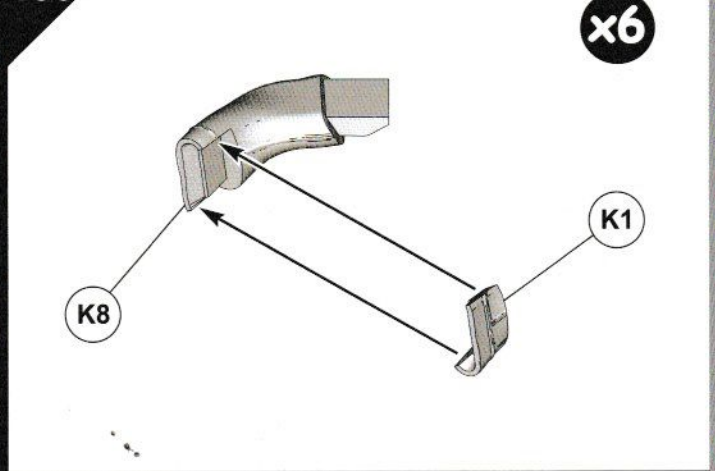

200

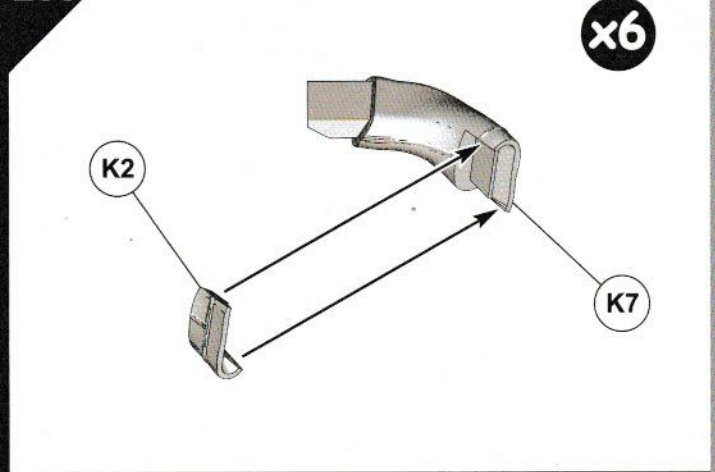

201

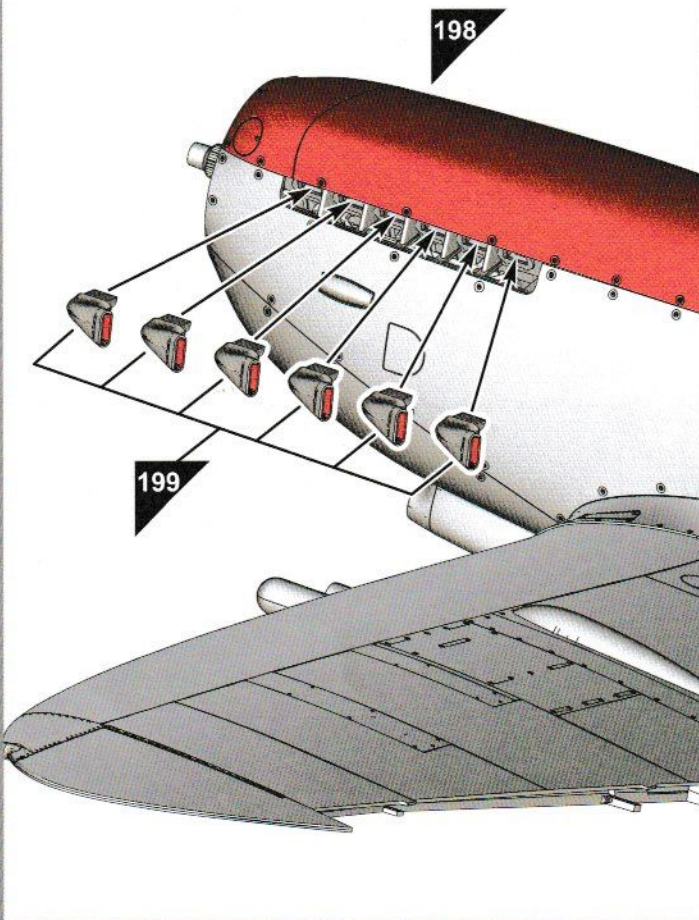

202

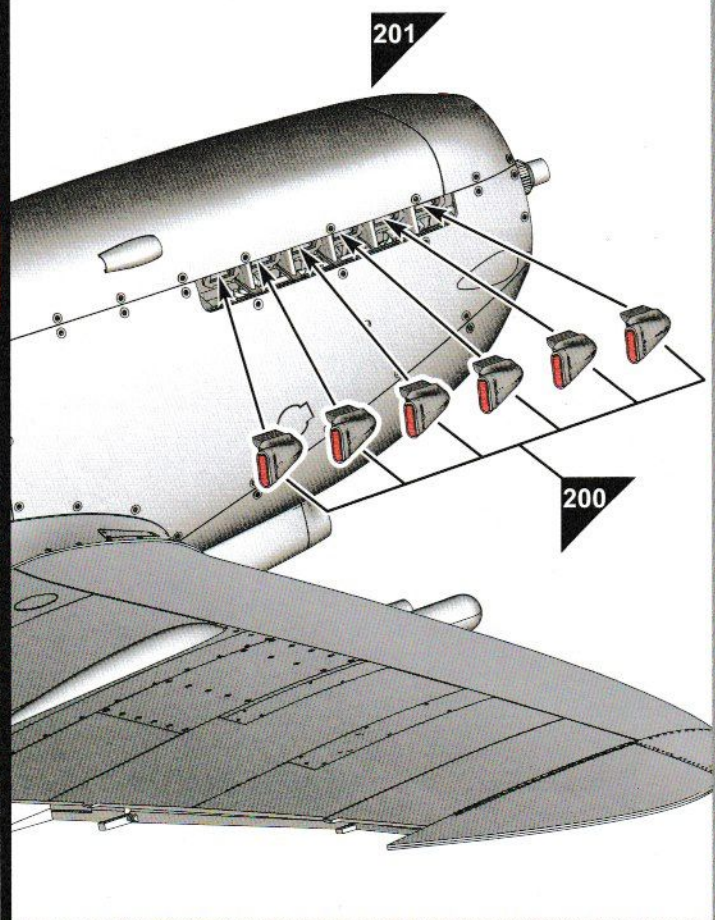

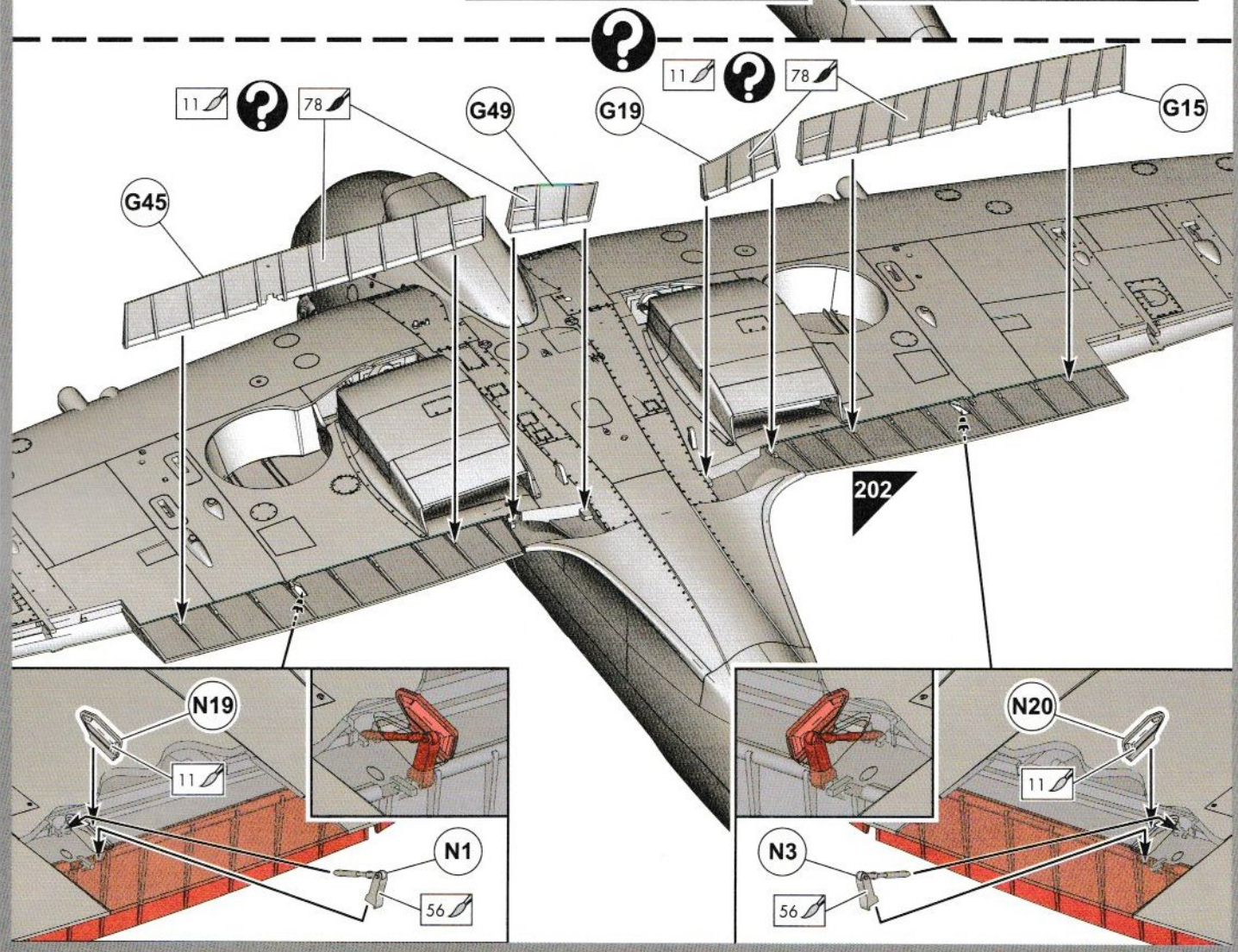
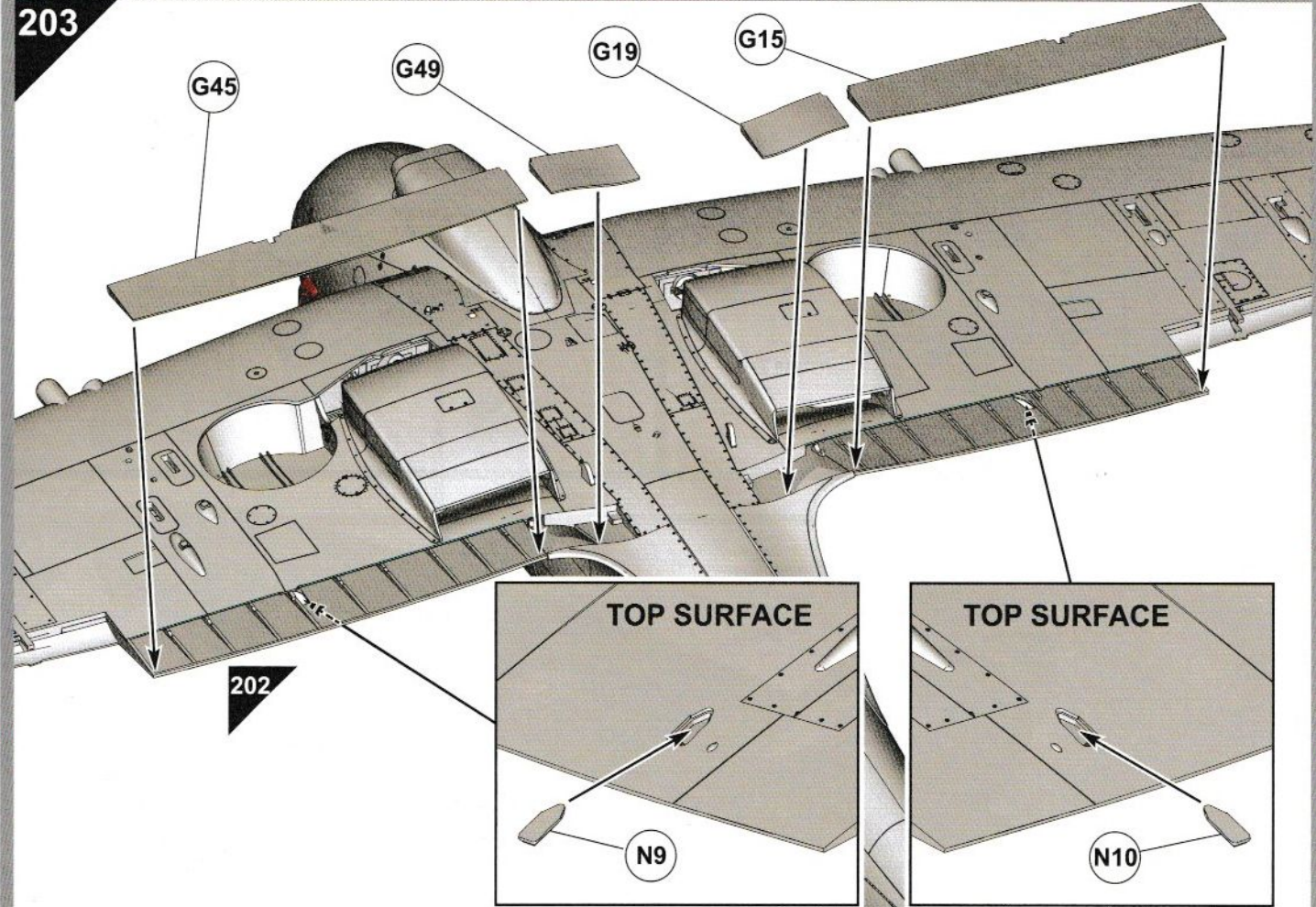

204

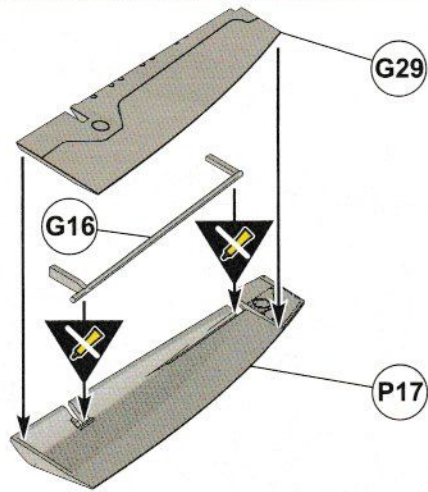

205

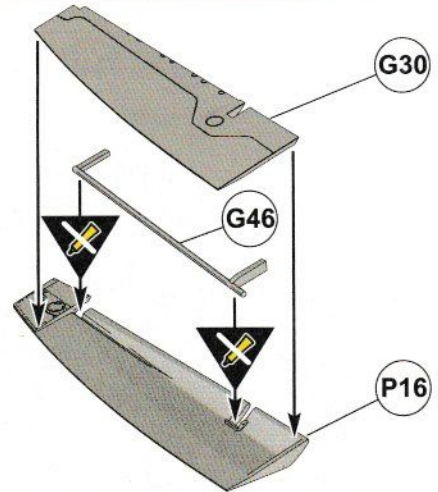

206

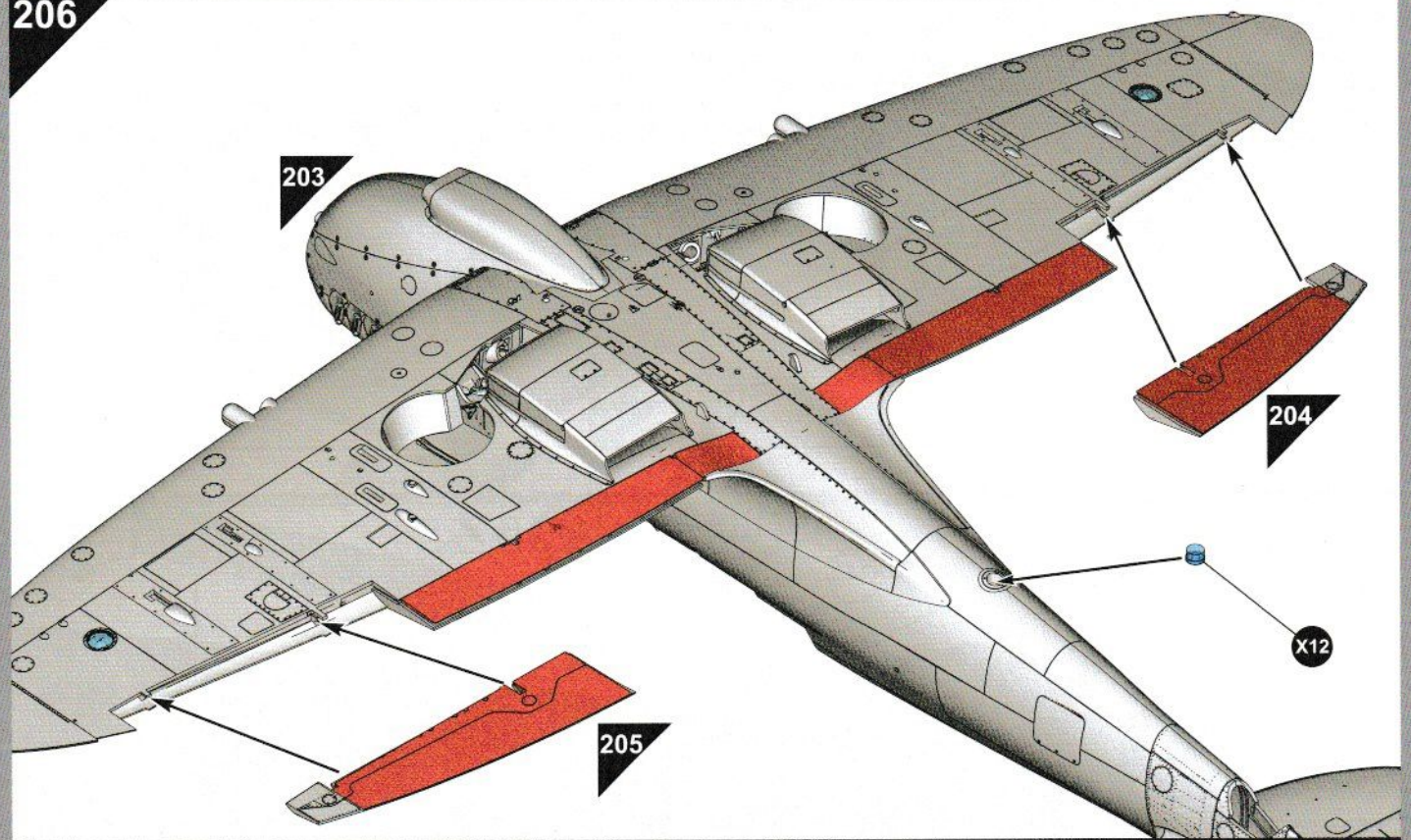

207

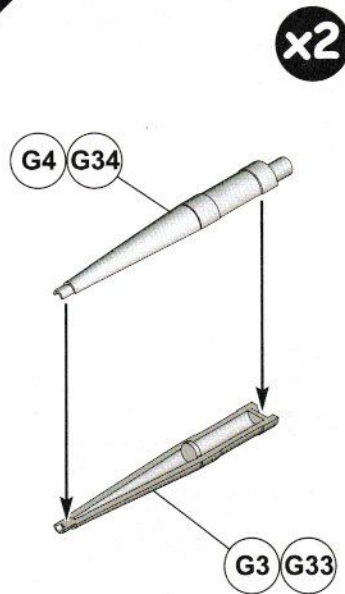

208

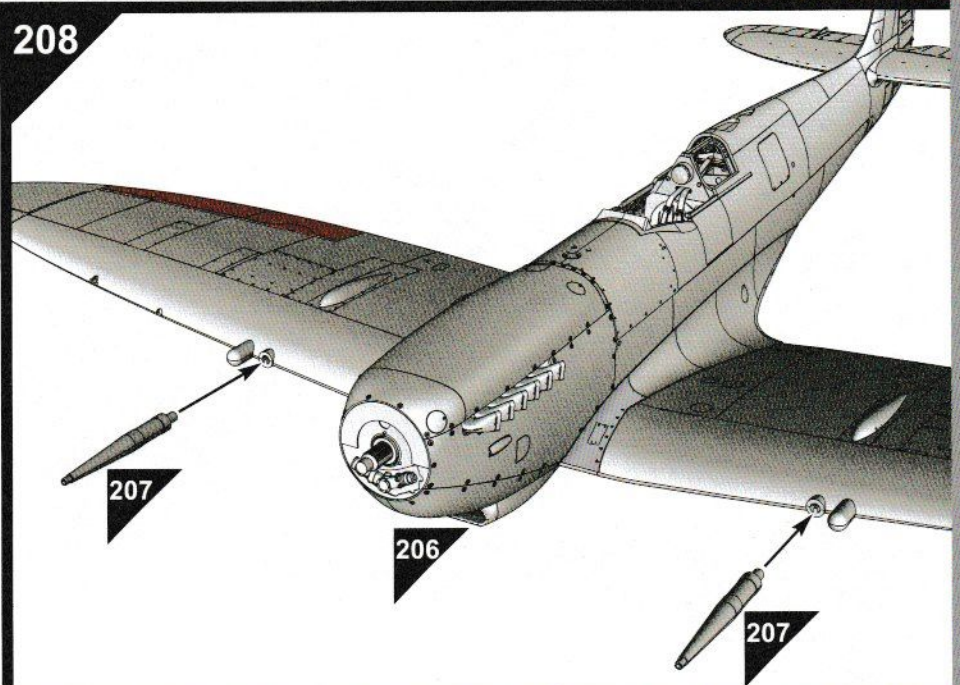



Note: If building this model with the undercarriage **UP**, follow steps 209 to 216 below on page 39 and miss out steps 217 to 230 on pages 40 & 41. If building this model with the undercarriage **DOWN**, miss out steps 209 to 216 below on page 39 and go to step 217 on page 40.

209

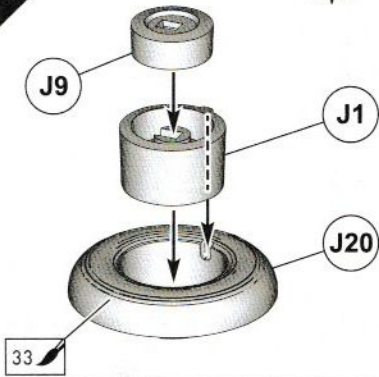

210

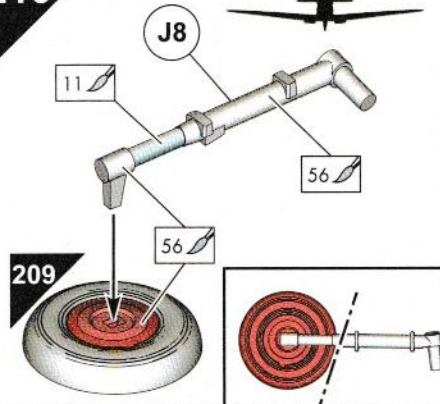

211

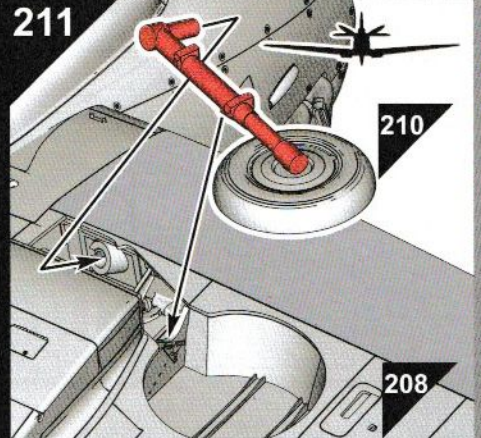

212

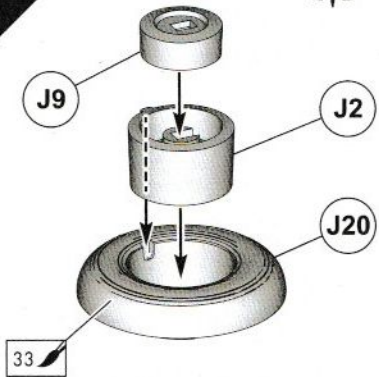

213

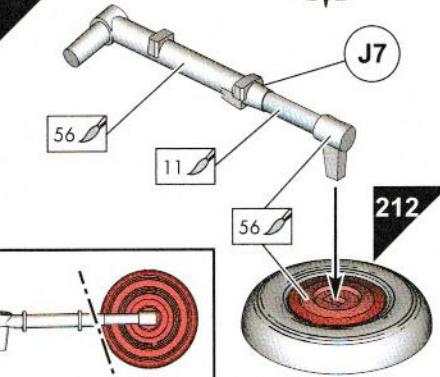

214

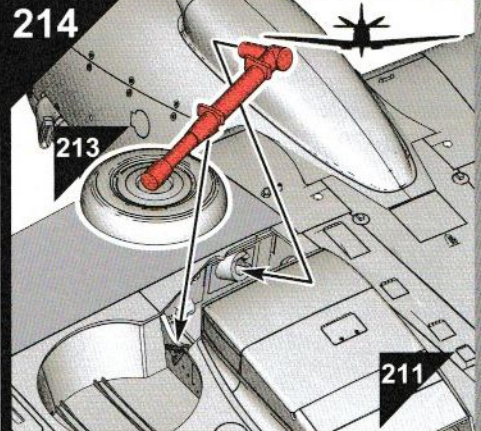

215

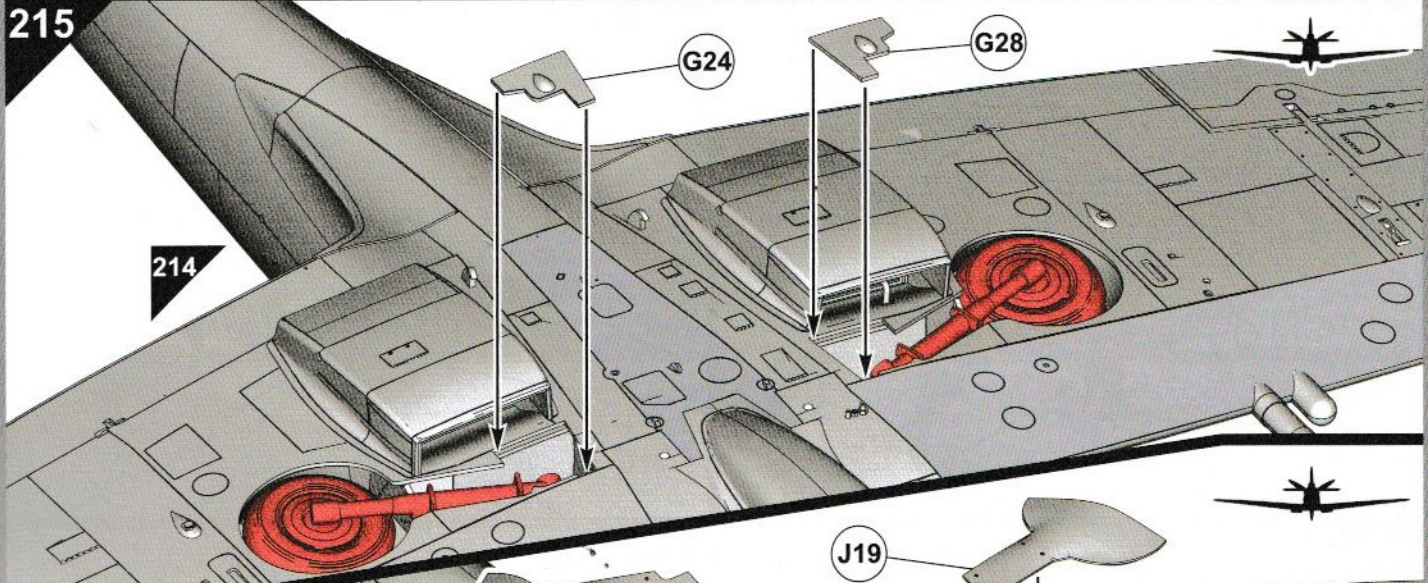

216

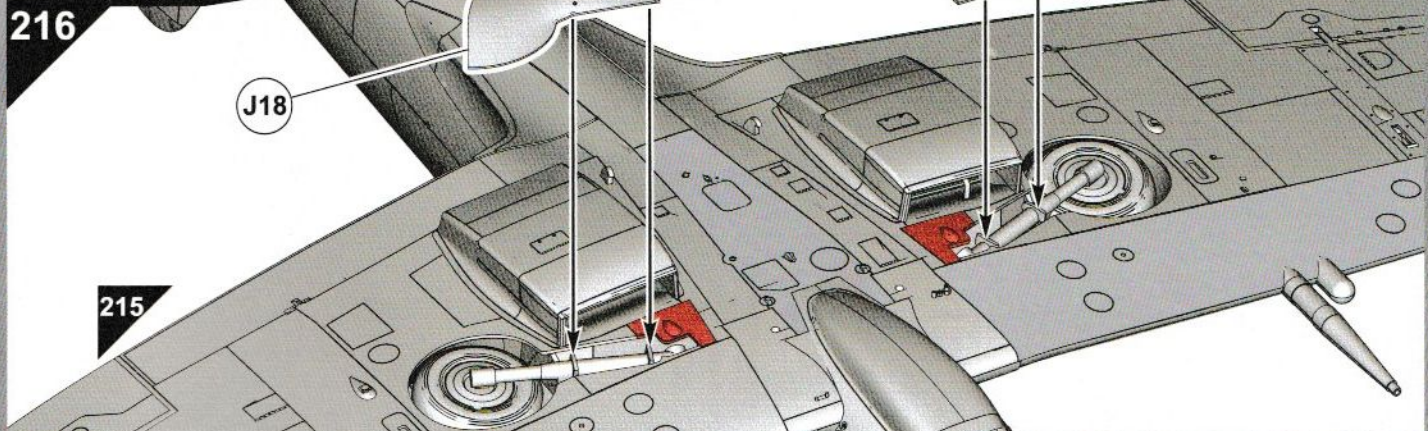

217

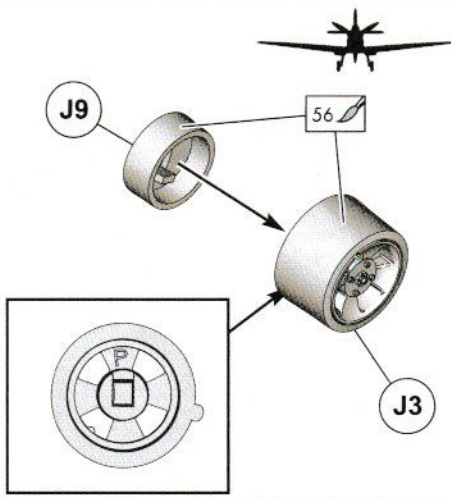

218

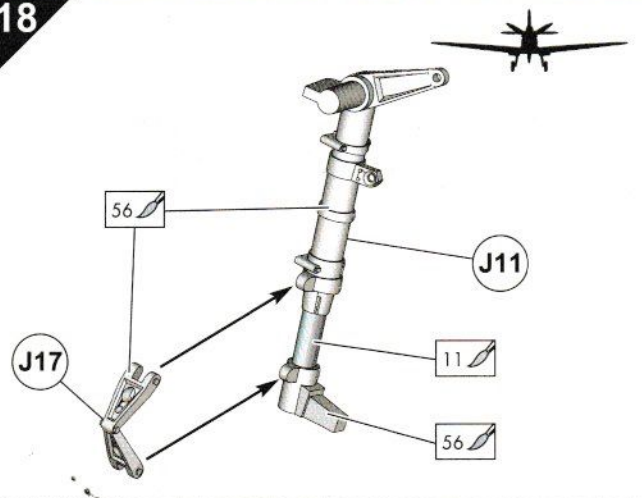

219

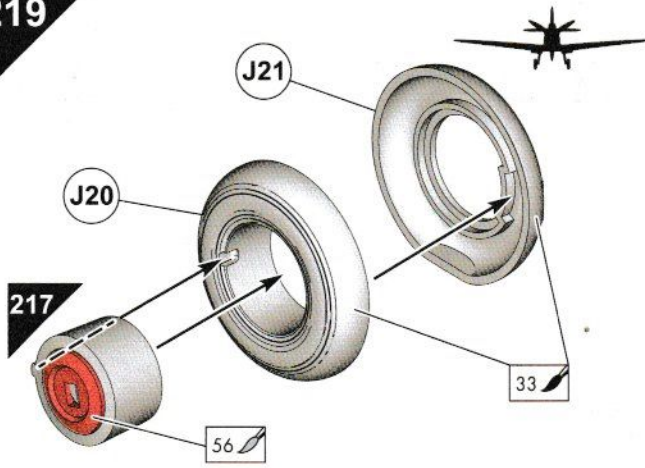

220

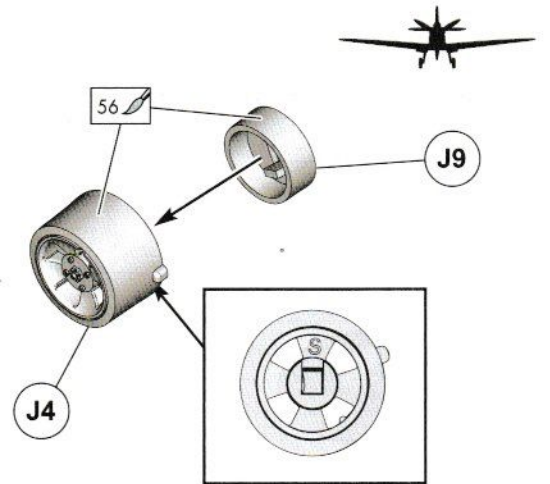

221

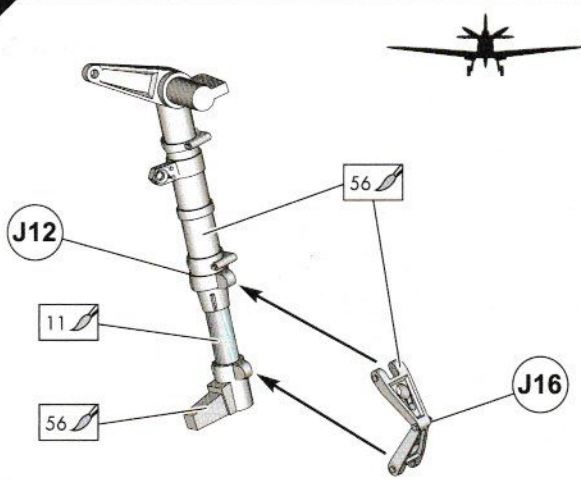

222

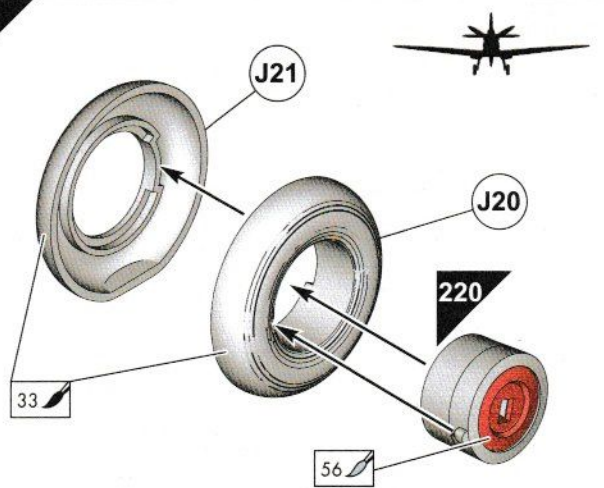

223

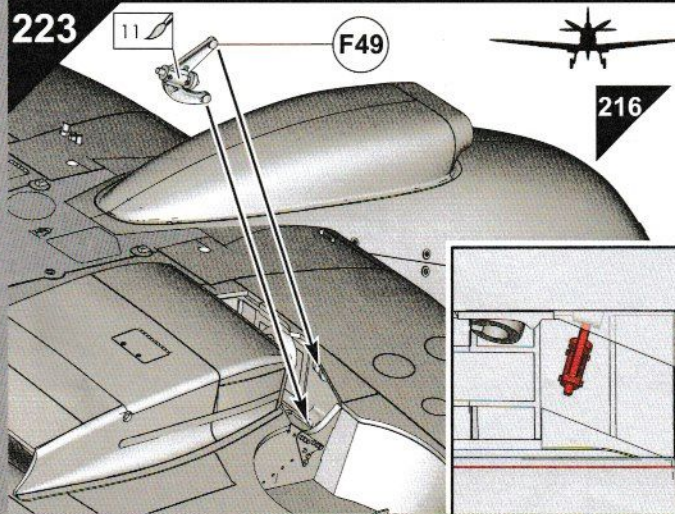

224

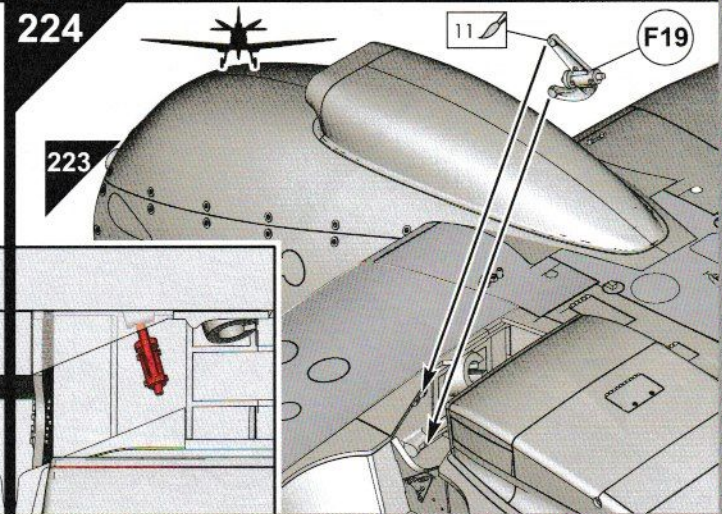

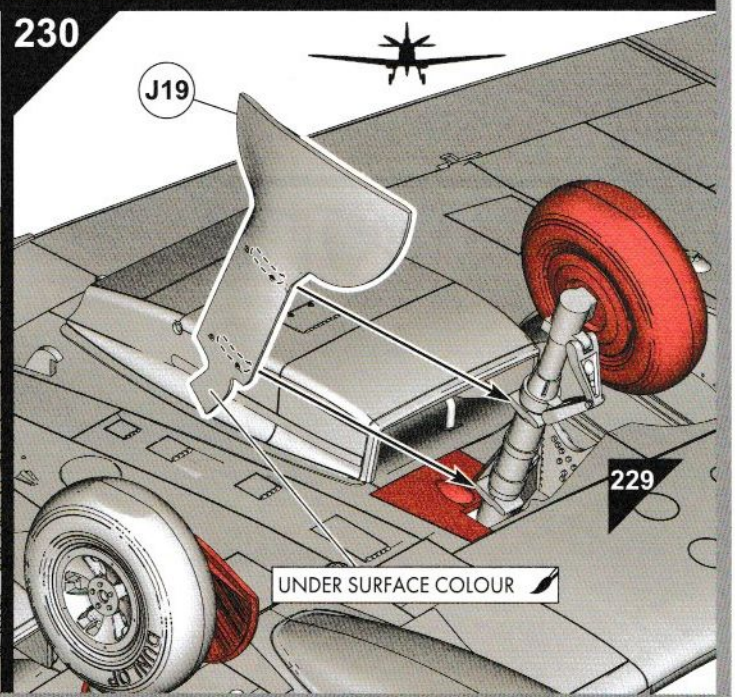
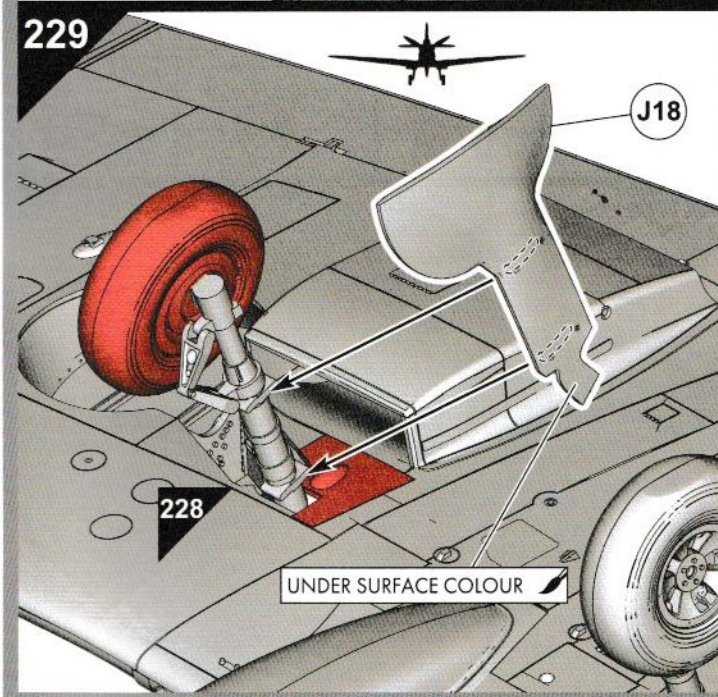
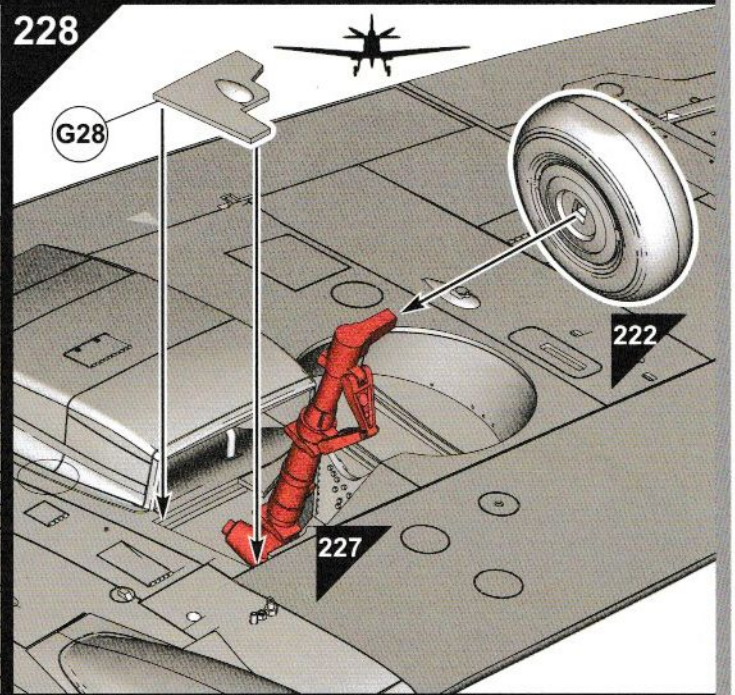
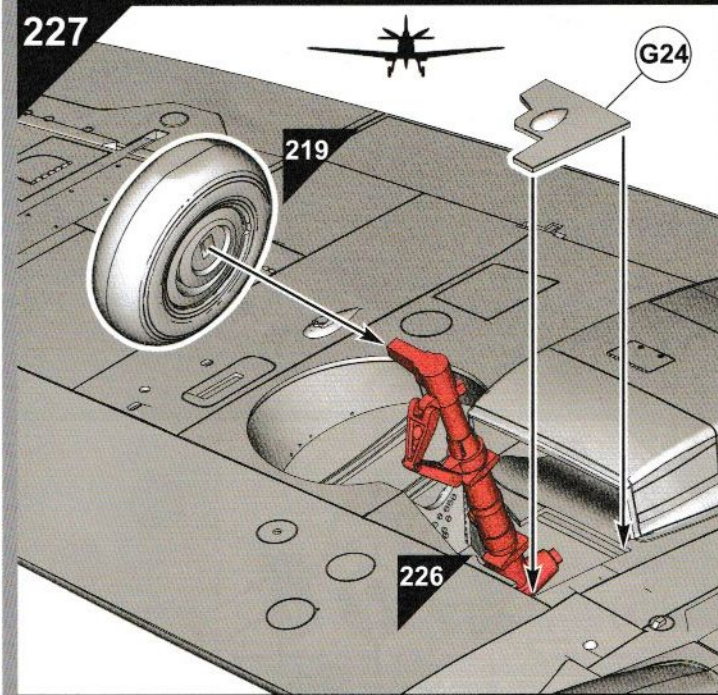
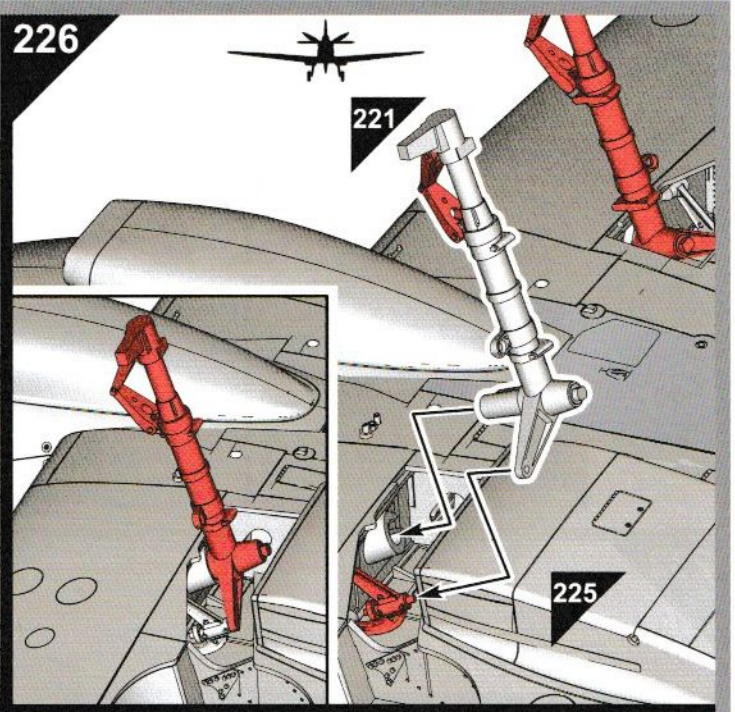
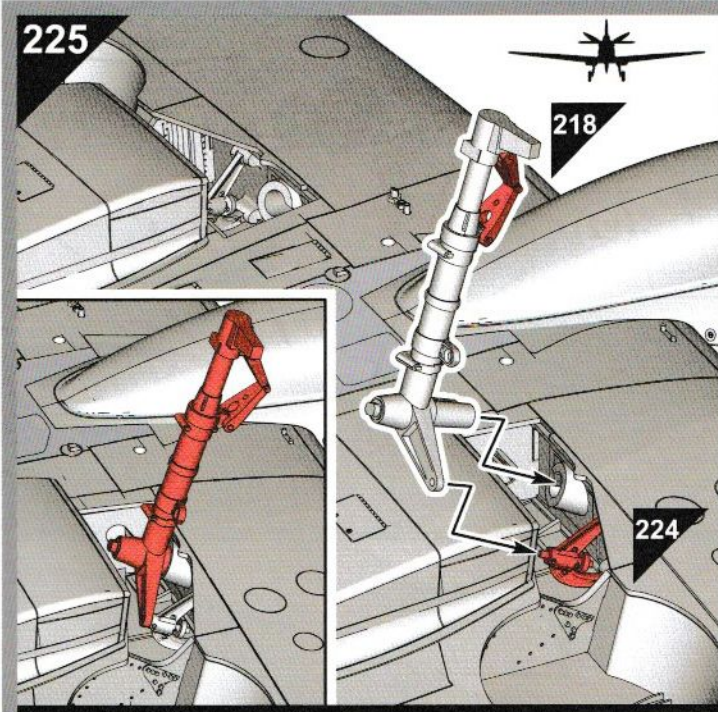

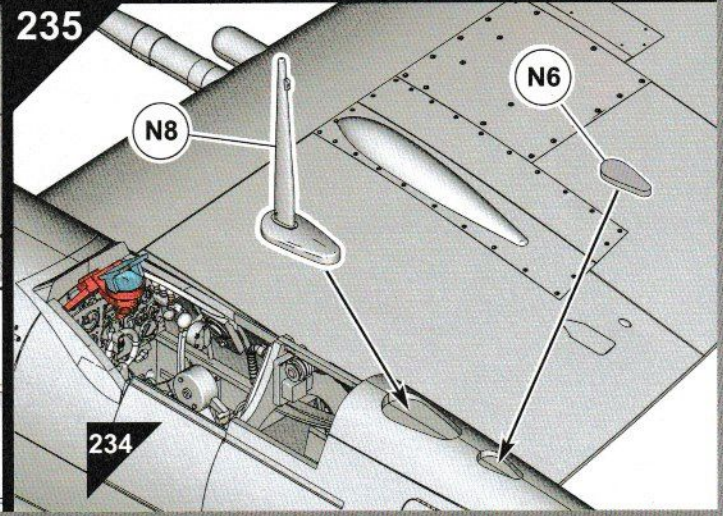
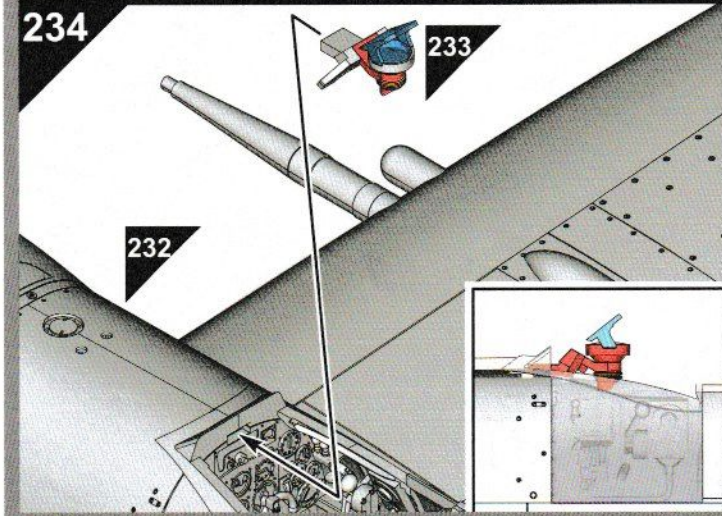
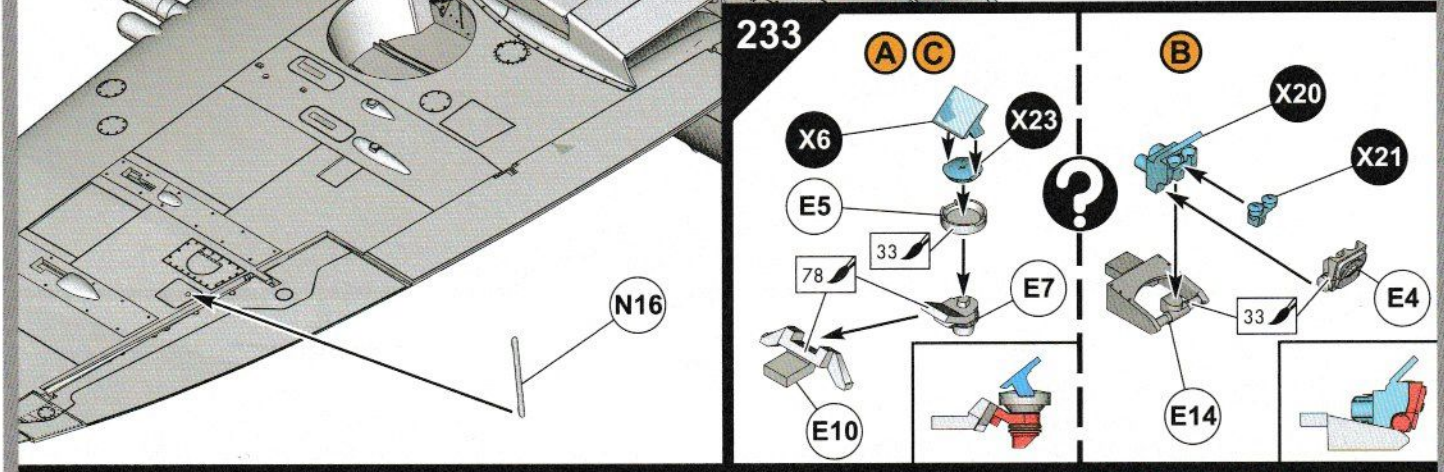
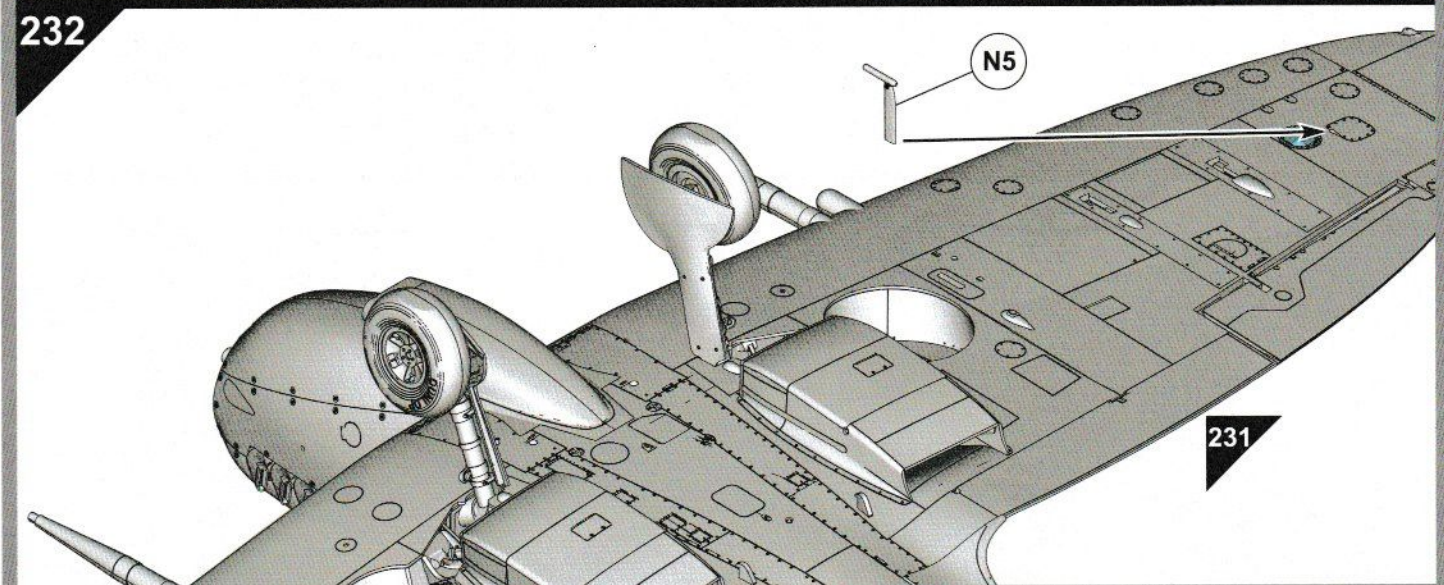
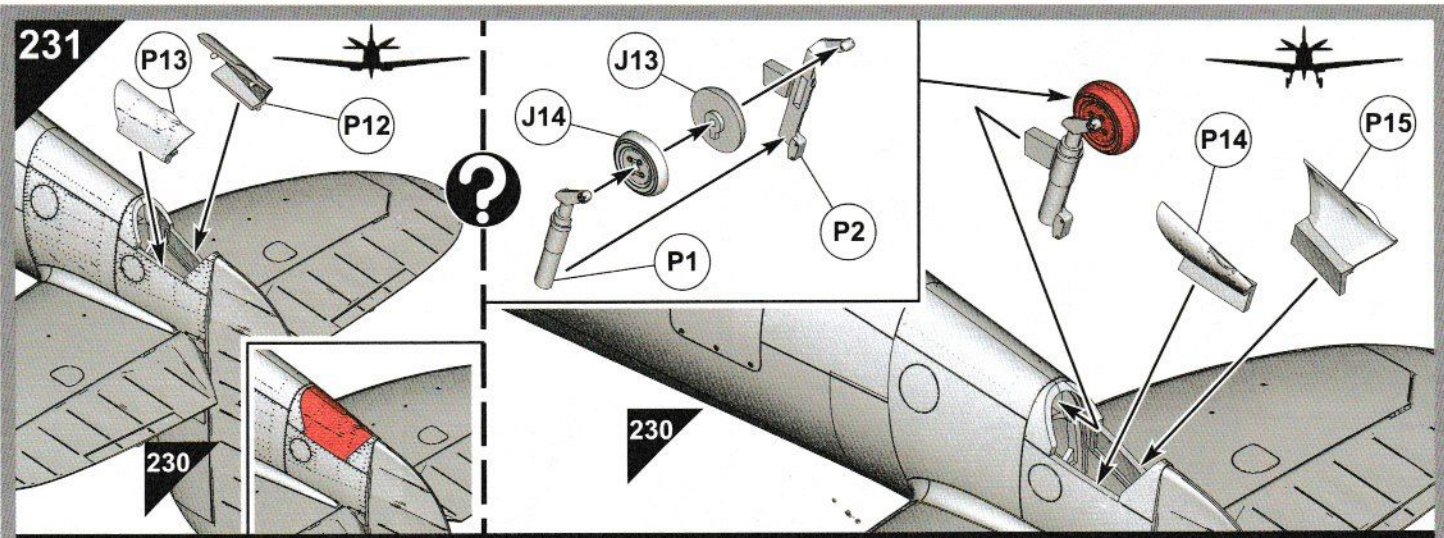

236

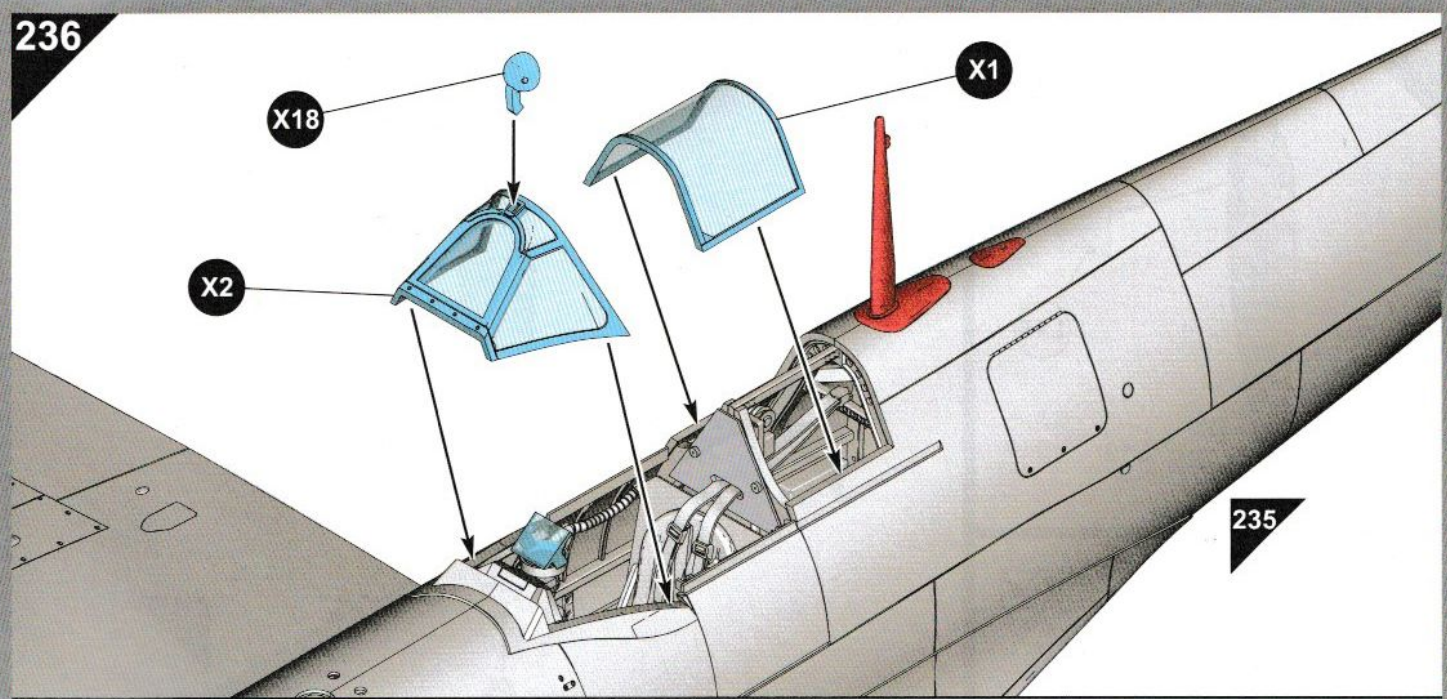

237

Note: It is not possible to make the true bulged shape of the Spitfire canopy without having the seam line through the centre. It should be possible to polish out the seam line from X22 but if preferred we have included an alternative canopy X15 which is less bulged but has no seam line.

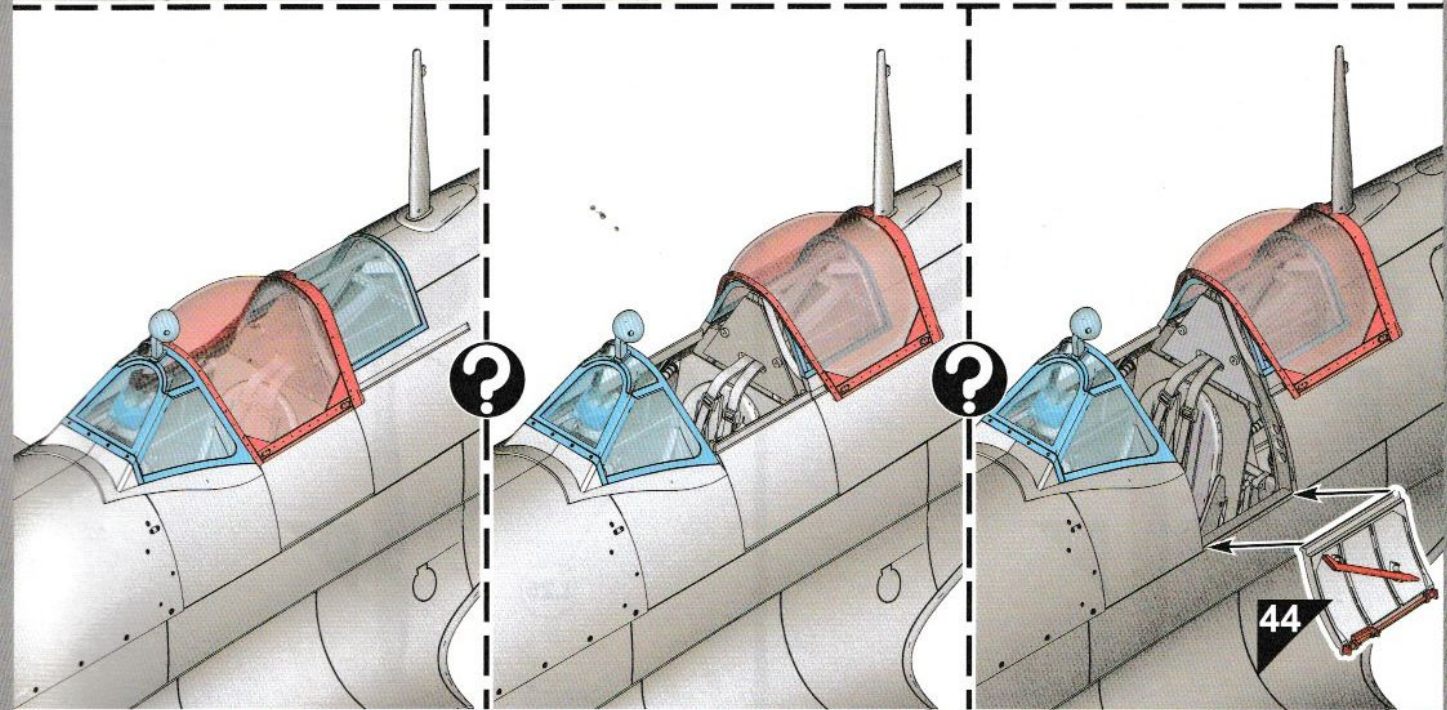
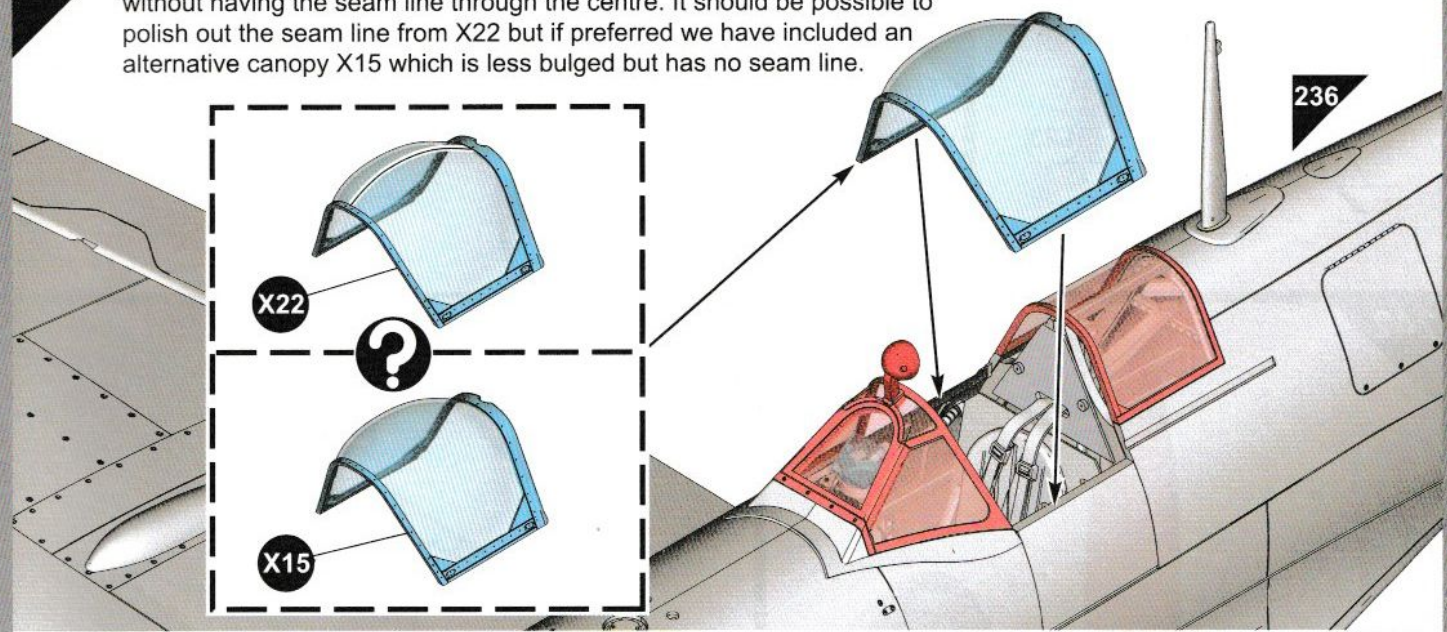

238

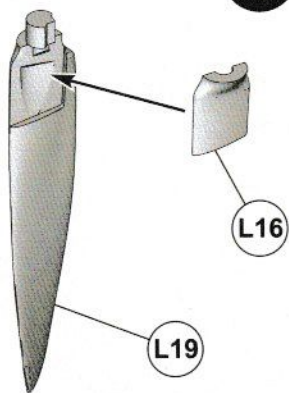

240

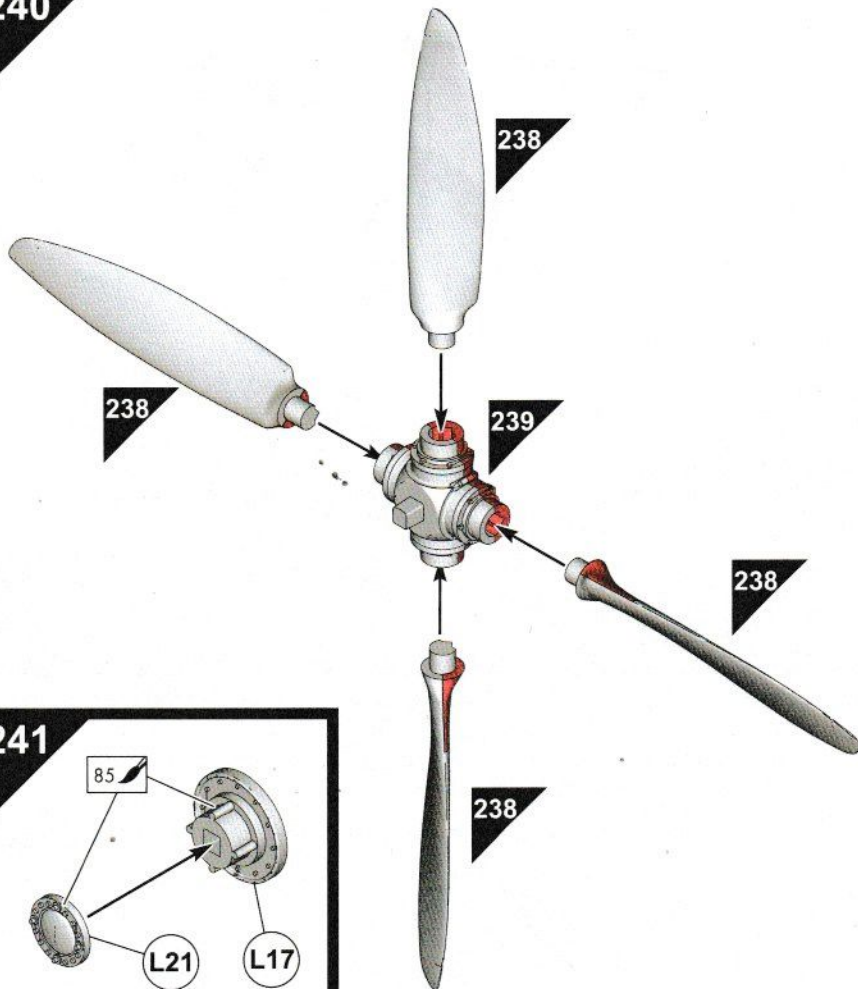

239

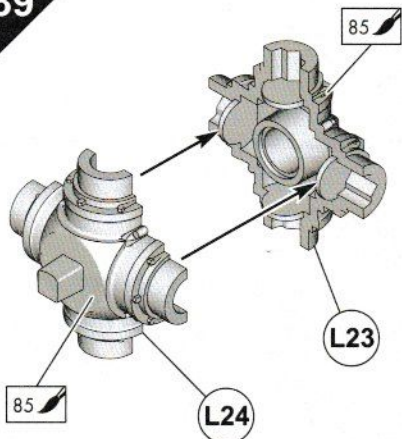

241

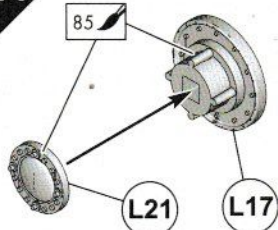

242

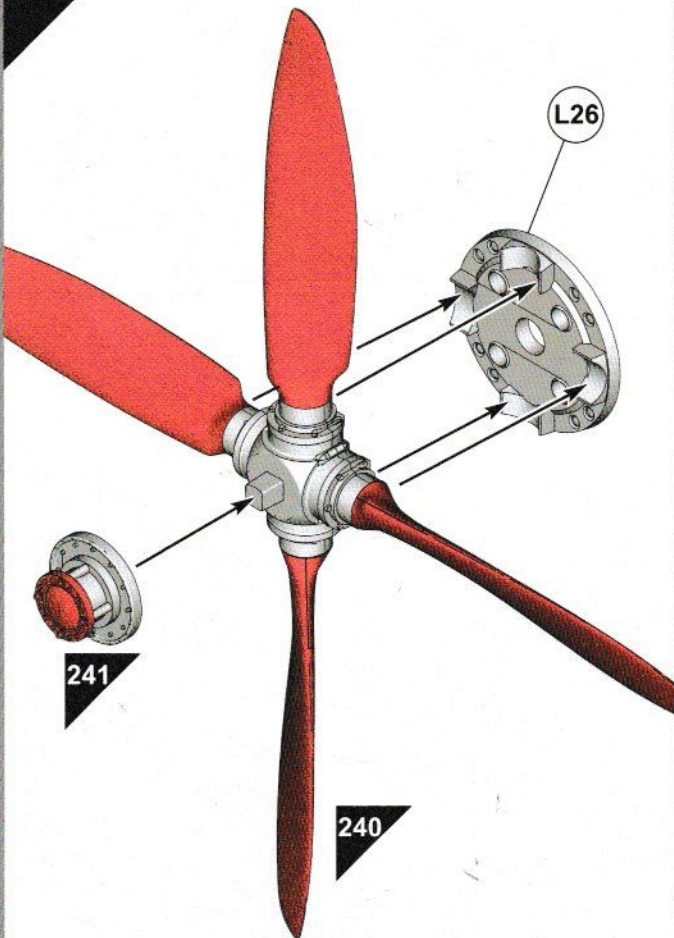

243

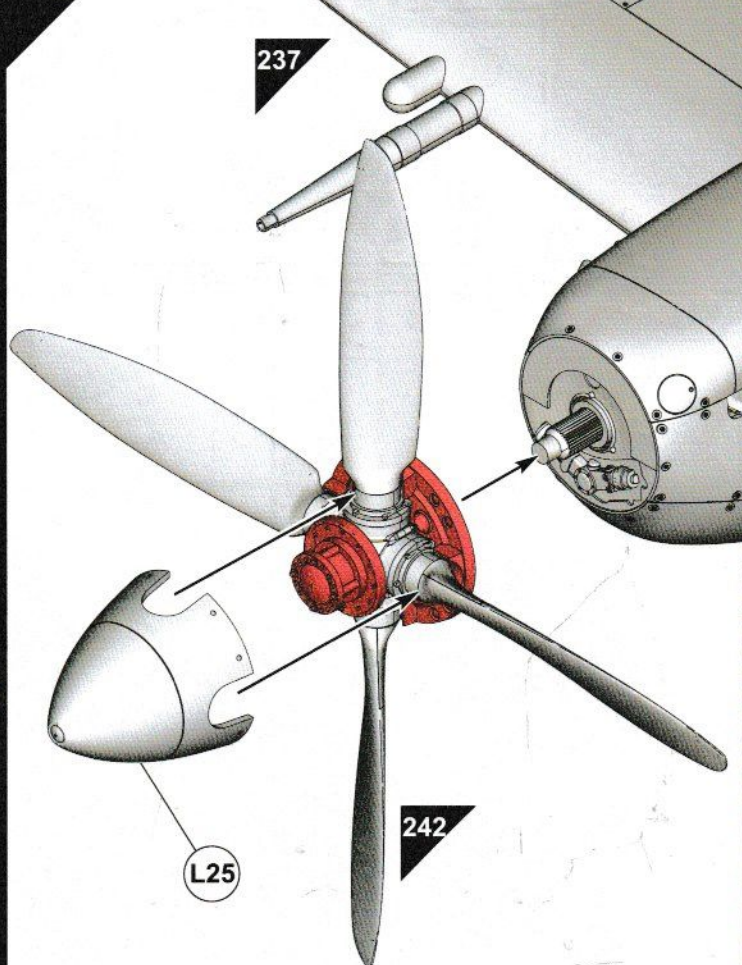

A Supermarine Spitfire Mk.VIII
 Sqn Ldr Bruce Watson, No. 457 'Grey Nurse' Squadron,
 Royal Australian Air force, Morotai, 1945

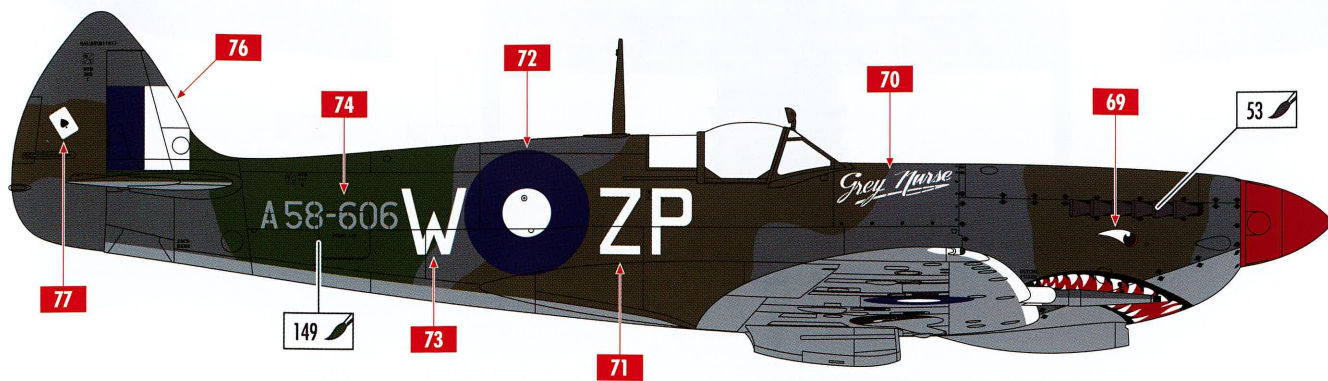
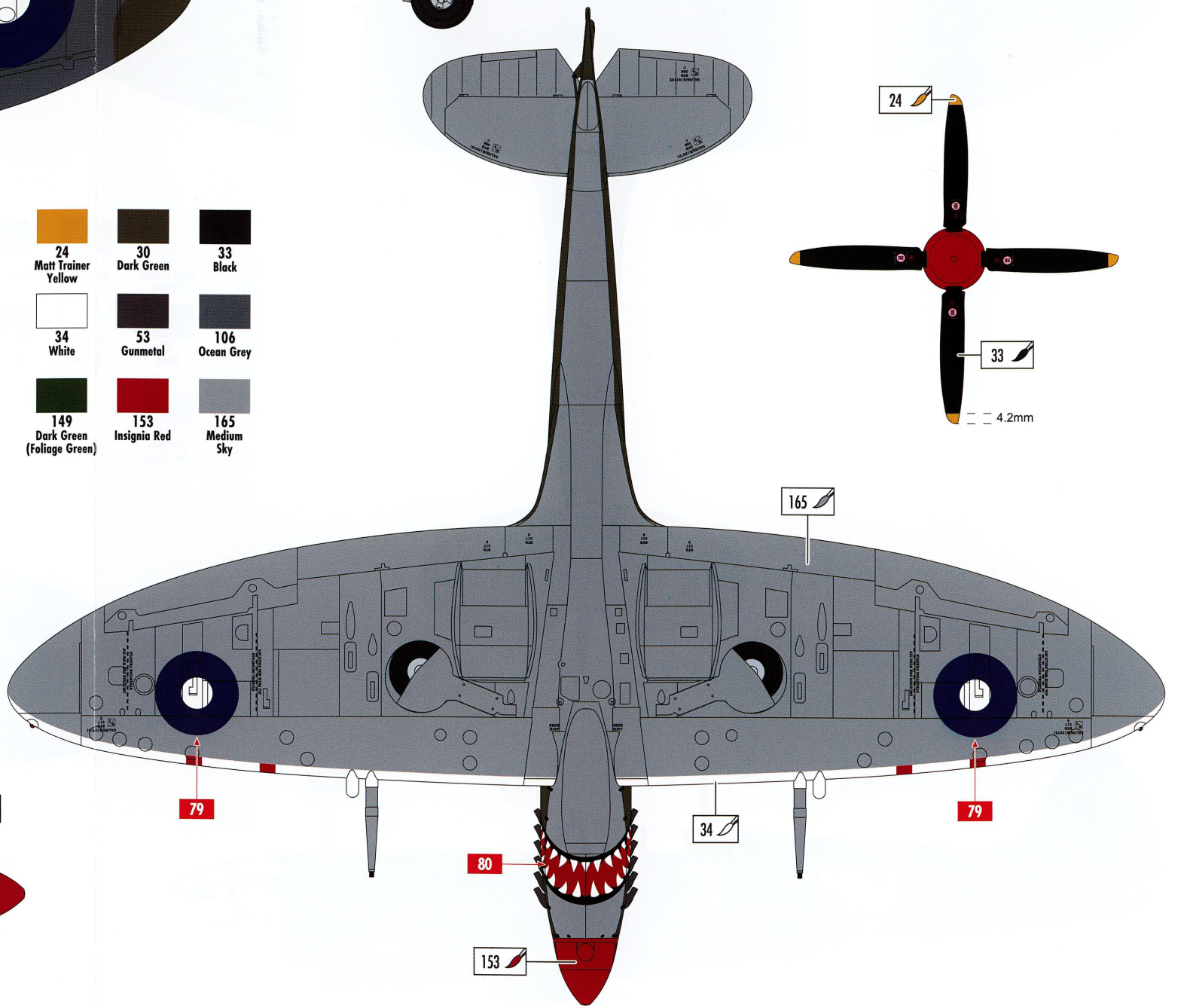
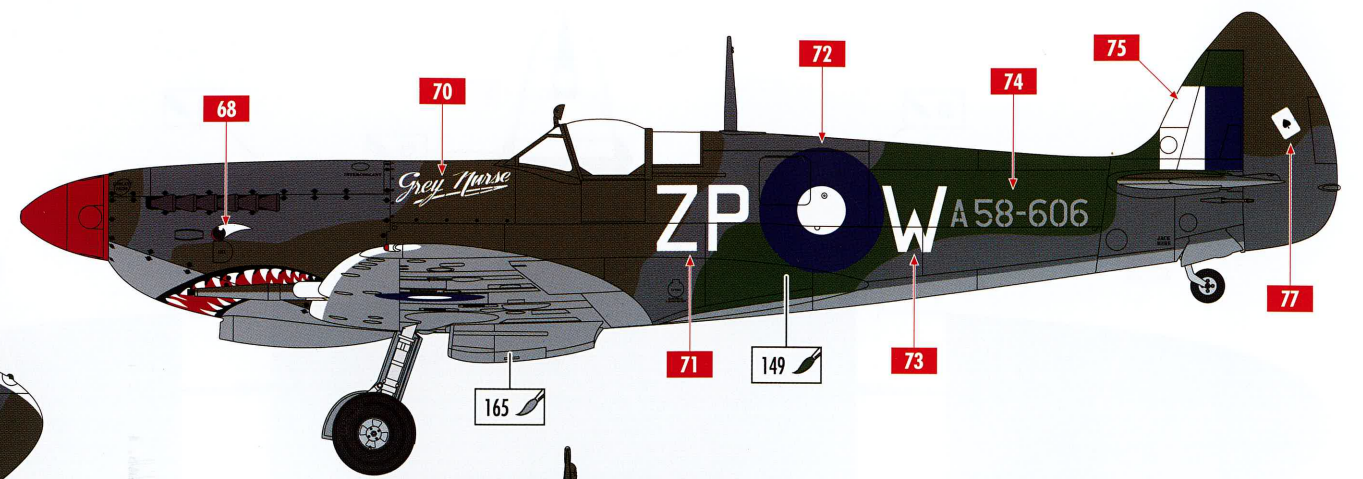
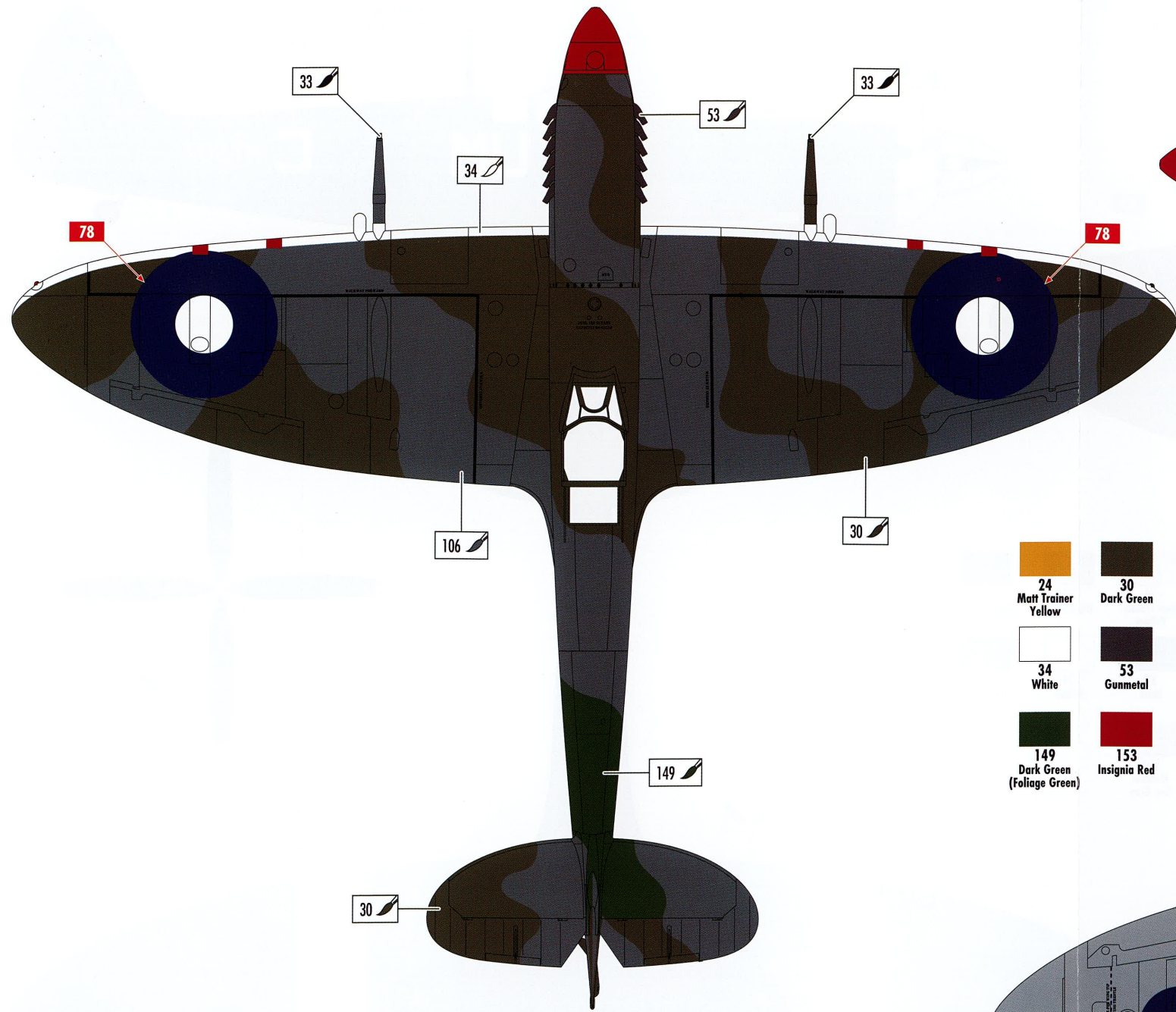



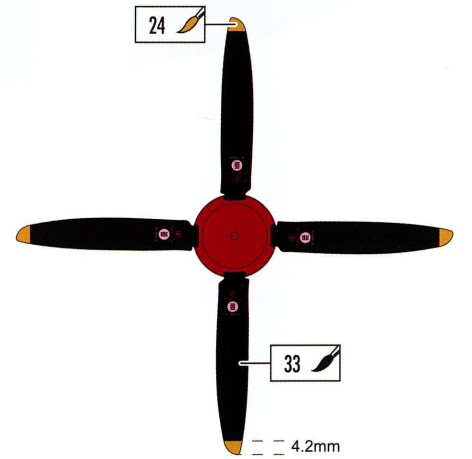

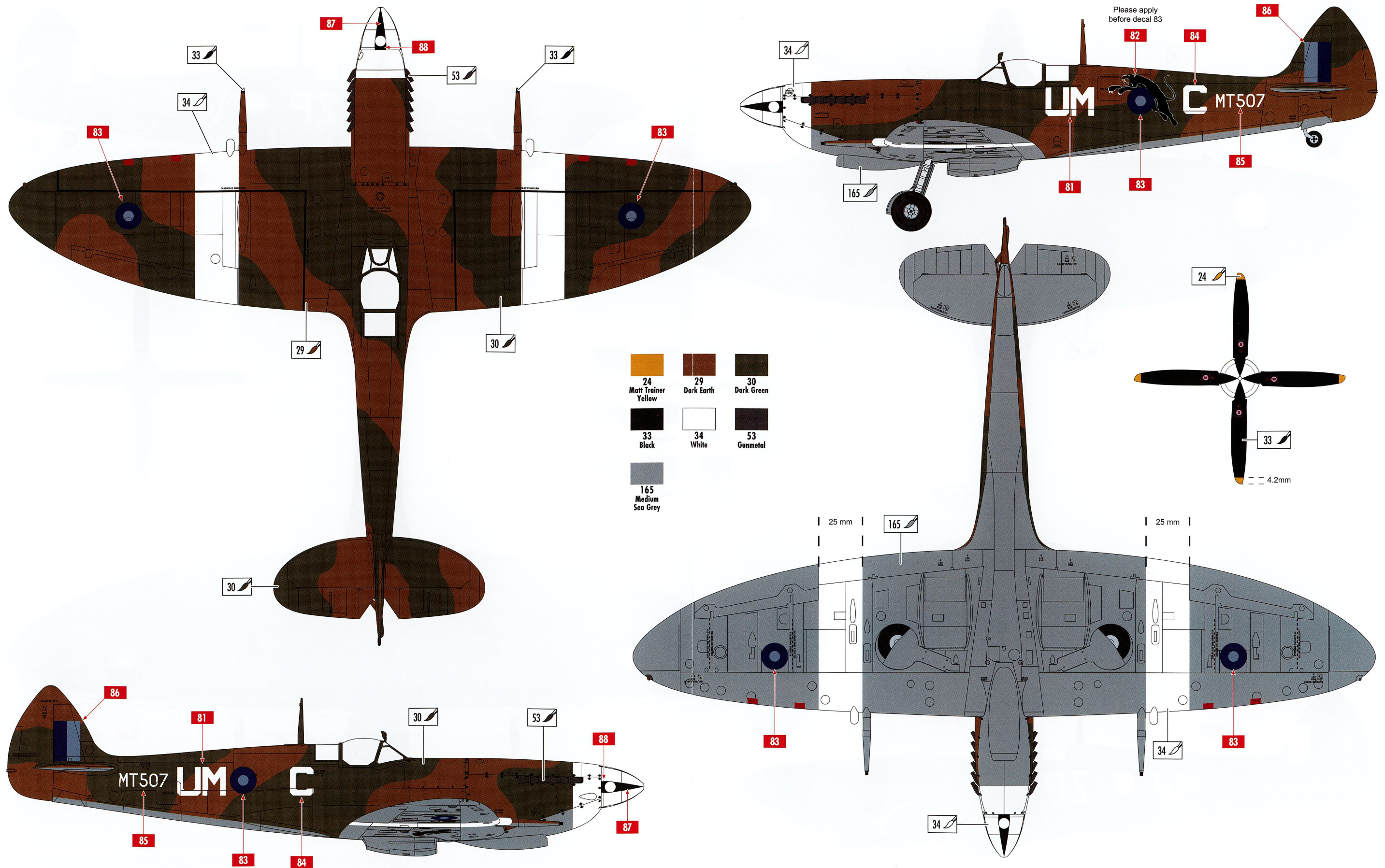

		
24 Matt Trainer Yellow	30 Dark Green	33 Black
		
34 White	53 Gunmetal	106 Ocean Grey
		
149 Dark Green (Foliage Green)	153 Insignia Red	165 Medium Sky



B Supermarine Spitfire Mk.VIII
 No. 152 (Hyderabad) Squadron, Sinthe, Burma, 1945





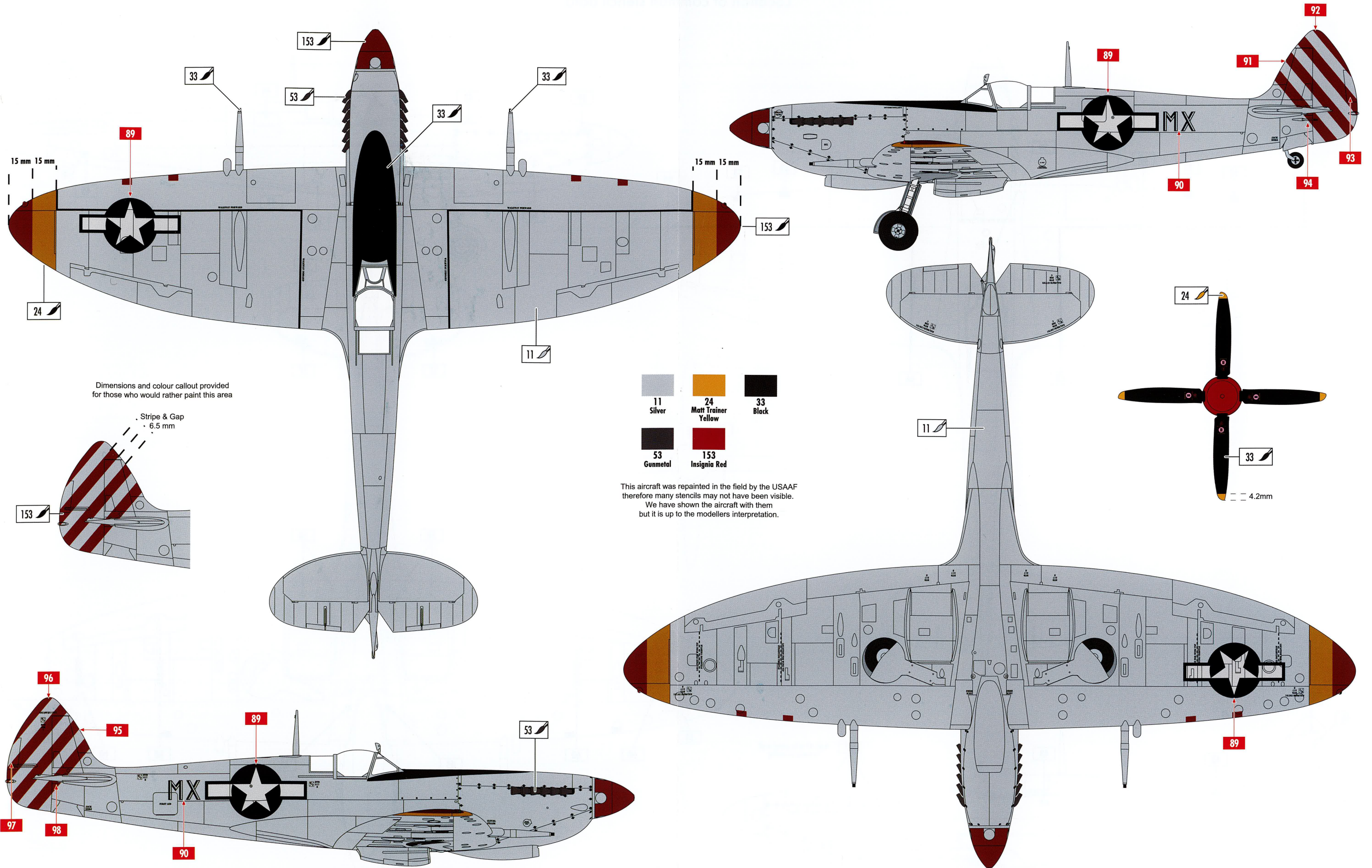

 24 Matt Trainer Yellow	 29 Dark Earth	 30 Dark Green
 33 Black	 34 White	 53 Gunmetal
 165 Medium Sea Grey		

© Supermarine Spitfire Mk.VIII
 307th Fighter Squadron, 31st Fighter Group, USAAF, Italy 1944



Dimensions and colour callout provided for those who would rather paint this area

Stripe & Gap
 6.5 mm

 11 Silver	 24 Matt Trainer Yellow	 33 Black
 53 Gunmetal	 153 Insignia Red	

This aircraft was repainted in the field by the USAAF therefore many stencils may not have been visible. We have shown the aircraft with them but it is up to the modellers interpretation.

Supermarine Spitfire Mk.VIII

Location of common stencil data

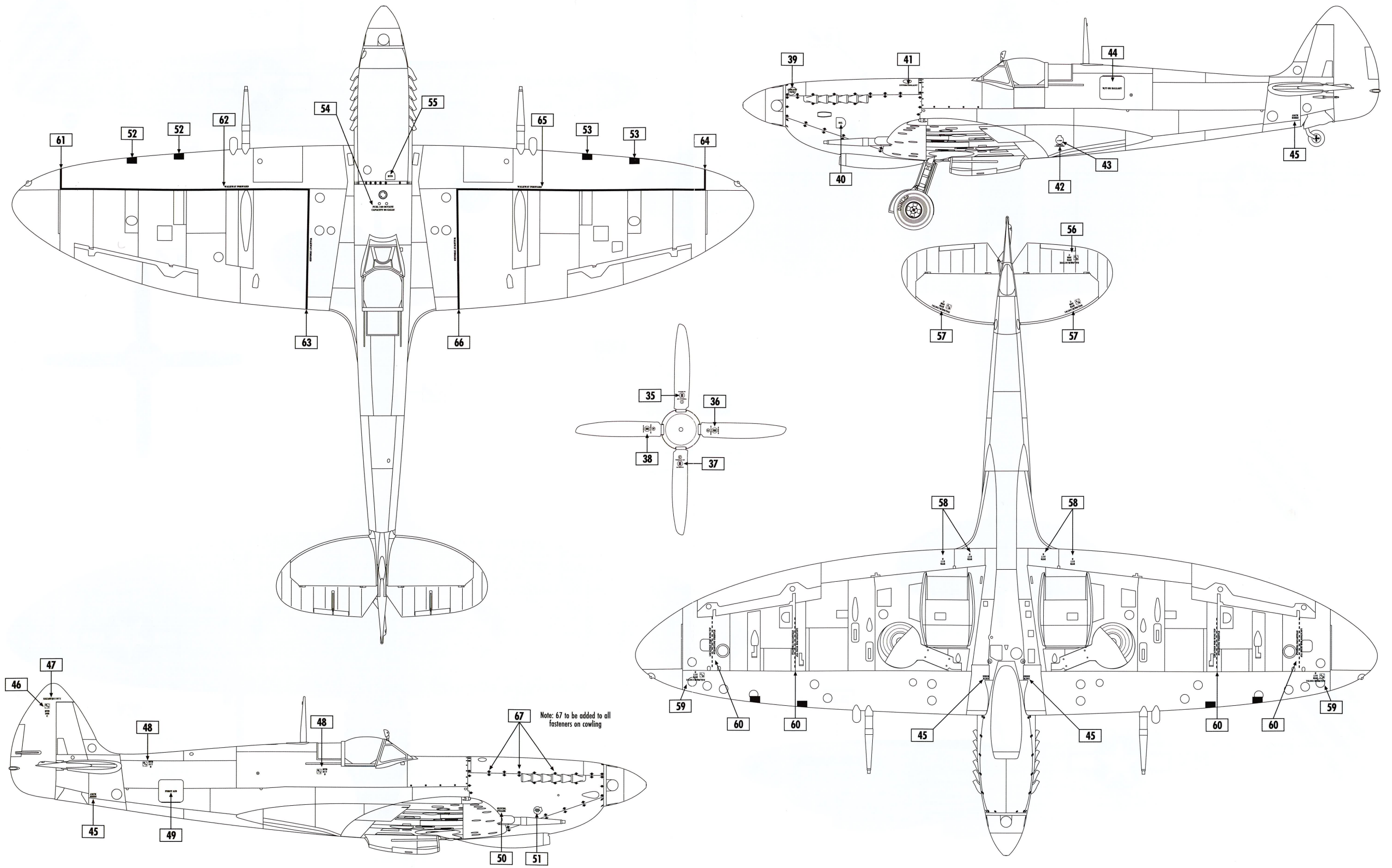

1 2 3 4 5 6 7 8 9 10 11 12 13 14 15 16 17 18 19 20 21 22 23 24 25 26 27 28 29 30 31 32 33 34 35 36 37 38 39 40 41 42 43 44 45 46 47 48 49 50 51 52 53 54 55 56 57 58

COOLANT 70/30 [39] OIL INTERCOOLANT [41] [42] ELECTRICAL [43] SECRET [44] W/T OR BALLAST [45] JACK HERE [46] JACK HERE [47] JACK HERE [48] JACK HERE [49] SAL/6S/R/11971 [50] W/T DTD 517 S [51] DTD 517 S [52] FIRST AID [53] GLYCOL FILLER [54] FUEL 100 OCTANE CAPACITY 96 GALLS [55] HYD [56] SAL/6S/R/16779X [57] W/T DTD 308 C [58] SAL/6S/R/126791 [59] W/T DTD 308 C [60] SAL/6S/R/126791 [61] W/T DTD 517 S [62] SAL/6S/R/126791 [63] W/T DTD 517 S [64] LOCATION FOR WING TIP STEADYING TRESTLE [65] LOCATION FOR WING TIP STEADYING TRESTLE [66] LOCATION FOR WING TIP STEADYING TRESTLE [67] LOCATION FOR WING TIP STEADYING TRESTLE

WALKWAY INBOARD [63] WALKWAY INBOARD [66] WALKWAY FORWARD [62] WALKWAY FORWARD [65]

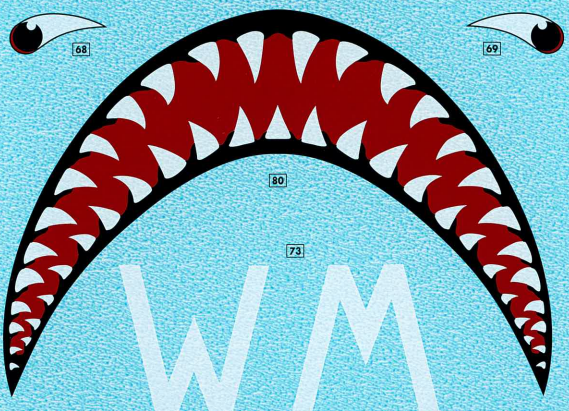

Grey Nurse Grey Nurse

[70]

A 58-606 A 58-606

[74]

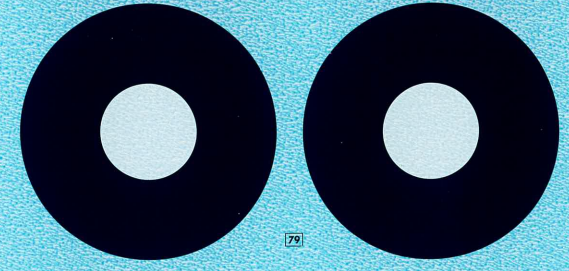
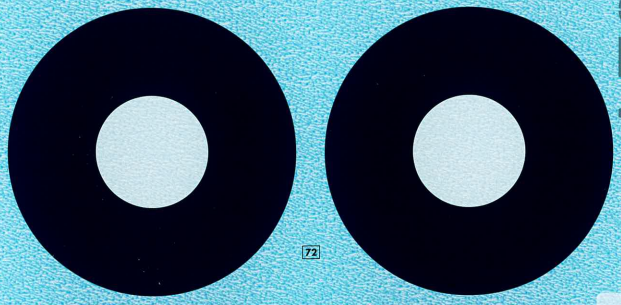
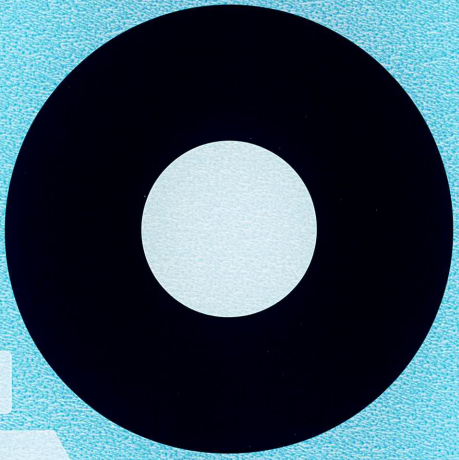
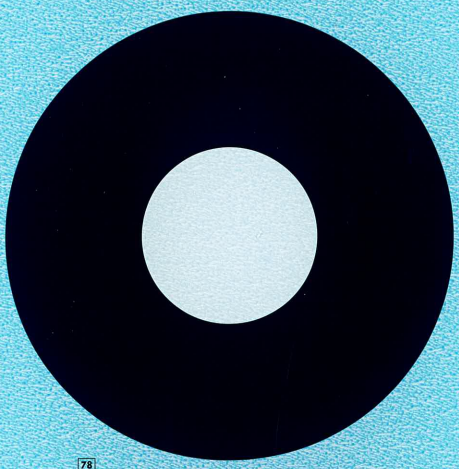

ZP ZP

[71]

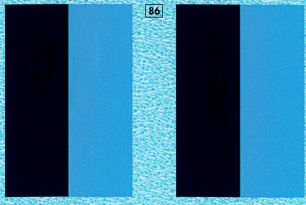
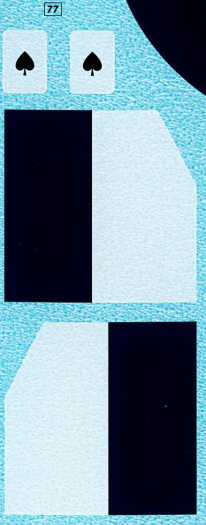

UM UM

[81]

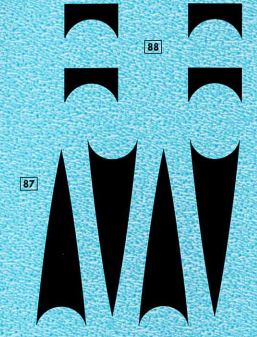
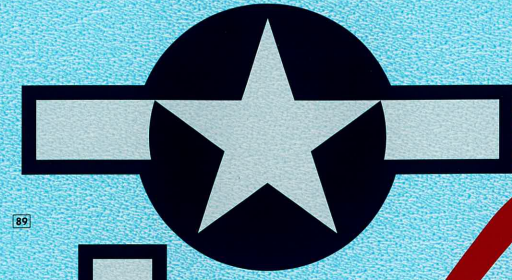
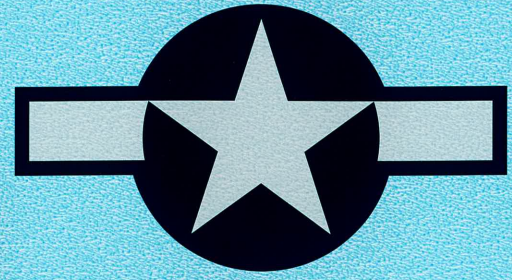

CCC

[84]

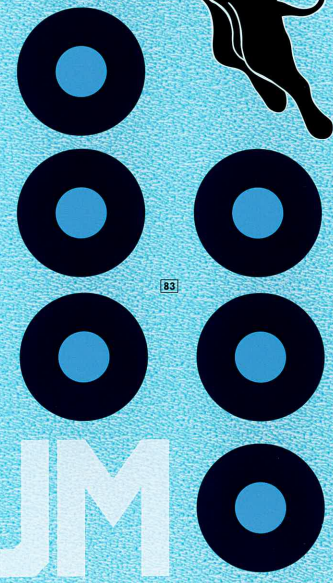
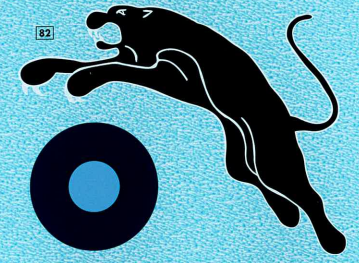

MT507 MT507

[85]

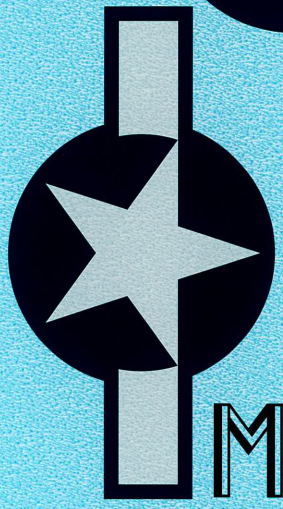

MX

[90]

MX

[92]

