

**eduard**

**LIMITED  
EDITION**



# GUSTAV

Pt.3

Bf 109G-6/AS & Bf 109G-14/AS

**INSTRUCTION SHEET**

**1/72**

**DUAL COMBO**

2150-NAV1



Illustration: Adam Tooby

# GUSTAV

Bf 109G-6/AS & Bf 109G-14/AS

by VLADIMÍR ŠULC

**The development of late versions of the Bf 109G, manufactured in a series of related and therefore similar versions, was the German aviation industry's response to a requirement to quickly supply Luftwaffe units with high performance fighters to combat the Allied bombing offensive of the spring of 1944.**

The anticipated replacement of the then standard Messerschmitt Bf 109G-6/G-14 with the Bf 109K, powered by the DB 605D, was not yet possible in the spring of 1944 due to the protracted development of the airframe and engine alike. The design element of Messerschmitt in Regensburg found an interim solution by installing the DB 605AS into the Bf 109G-6, and this modification made use of items that were already designed and were construction ready, intended to be used in the engine installation in the Bf 109K.

### Engine in the center of attention

Simply put, the DB 605AS and DB 605D were created by installing the larger supercharger from the DB 603 in the DB 605A. The performance of these superchargers was around 25 % greater than the ones installed in the DB 605A. The first developmental version of the DB 605 outfitted with the larger supercharger was the DB 605AS, originally designated as the DB 605A (Sonder). The intended fuel for these engines was the B4 with an octane rating of 87. The first DB 605AS engines were available at the beginning of 1944. As spring became summer that year, the DB 605ASM appeared, burning C3 fuel with a 96 octane rating. Other versions of the AS engine were developed (ASCM, ASMO, ASB, ASC) utilizing various combinations of B4 and C3 fuels, and different GM1 nitrous oxide boost systems and variations of the MW 50 injection system for short term power output of the engine. These included the GM1 (injection of nitrous oxide into the engine cylinders), MW 50 (injection of a 50:50 mixture of methanol + water into the compressor intake), MW 30 (methanol + water at 70:30), EW 50 (ethanol + water 50:50) and EW 30 (ethanol + water 70:30). The GM-1 and MW 50 systems could in some cases be installed together in the same airframe, but their simultaneous use was prohibited and practically impossible. Depending on the different sub versions of the engines used, the aircraft were equipped with different versions of radiator, oil tank and air intake to the supercharger compressor too. DB 605AS engines powered the Bf 109G-6/AS and Bf 109G-14/AS produced at Messerschmitt's Regensburg and Erla plants in Leipzig.

### Into production

The first version of the Bf 109G powered by the DB 605AS engine was the Bf 109G-6/AS. Its production began in April 1944 at the Messerschmitt factory in Regensburg, where 349 were produced as new builds in four production blocks (Block 163 000-163 994, 226 units from April to June 1944; Block 164 380-164 999, 37 units from August to December 1944; Block 165 001-165 999, 47 units from August to December 1944; Block 166 001-166 644, 39 units from August to December 1944).

Added to these numbers were 104 of Bf 109G-5 and 472 of Bf 109G-6 airframes rebuilt to AS standard between February and August, 1944 at Erla, Mimetall and Blohm & Voss

Besides a modified engine cowling with large oval fairings over the supercharger compressor and fuselage guns, known informally to Luftwaffe personnel as the "Horse's Ass", an updated and lightened canopy (Erlahaube), a larger diameter VDM 9-12159 propeller (same as the later G-10 and K-4) and a tall fin and rudder, the original design of the Bf 109G-6 was left intact. They were equipped with a standard Fo 870 radiator used in the G-6, the bottom section of the cowling was smooth without the two small fairings covering the oil pump, and the oil tank was also the same as on the G-6. The difference from the later G-10 came in the oil filler cap on the left side of the nose immediately above the small air intake which was in the same location as on the Bf 109G-6. In the G-10, the cover over the cap was placed higher due to the increase in size of the oil tank. The supercharger intake also remained the same as compared to the G-6, which was smaller than the later G-10. So that things weren't all that simple, some airframes of later production, or during refurbishment, received the larger diameter supercharger intakes and larger Fö 987 oil cooler that appeared on the Bf 109G-10. The oil coolers of these aircraft, produced by Erla, had the Erla specific Fö 987 cover developed for the later Bf 109G-10. It wasn't as deep as the same oil cooler mounted in the G-10 at Mtt. Regensburg and WNF. The cockpit canopy with a simplified Erlahaube frame was of the older type with sharp rear corners of

the opening part, new-build versions being equipped with a short antenna mast behind the cockpit. Some of the G-6 conversions had the mast mounted on the canopy frame. There were also versions without a mast altogether. The tailwheel strut was short and was with or without a dust cover, and the fairings above the wheel wells were as they were on the G-6. All aircraft were equipped with a FuG 25 IFF system with a small blade antenna on the bottom of the second fuselage section.

The part of these aircraft that were designated Bf 109G-6/AS/y were equipped with a FuG 16ZY DF homing system, the whip antenna for which was located under the wing below the fuselage.

Most aircraft had fuselage mounted MG 151/20 cannon, but a number of converted Bf 109 G-6/U4s were armed with a MK 108 30mm weapon firing through the propeller hub. These were designated Bf 109G-6/U4/AS and according to H. H. Vogt, 153 were produced.

### GM-1 and MW 50 magic

In the Bf 109G-6/AS, the MW 50 methanol water injection system installation was not yet a standardized feature and would have been recognizable by a box shaped opening located in the rear cockpit wall. Of course, that doesn't mean that the MW 50 system was not installed in the Bf 109G-6/AS. Some aircraft were so equipped. Bf 109G-6/AS aircraft equipped with MW 50 were designated Bf 109G-6/MW50/AS or Bf 109G-6/U3/AS, and later redesignated as Bf 109G-14/AS.

Aircraft designated Bf 109 G-6/U2/AS, on the other hand, were equipped with the GM-1 injecting nitrous oxide into the engine cylinders, which increased engine power above 10,000 m (32,800 feet), in contrast to the MW 50 system, which increased engine power at lower altitudes of up to 6,000m (19,700 feet). The Bf 109G-6/U2/AS was to be built to the tune of 273 units. In addition to them, 23 photo reconnaissance Bf 109G-6/U2/R2/AS were produced, and probably some Bf 109G-8/AS airframes as well, but their production number is unknown.

As already mentioned in the introduction, high-altitude Bf 109G-5s were also converted to the Bf 109G-5/AS standard. They were essentially the same as the G-6/U2/AS, but there was a larger air intake on the left side of the fuselage below the cockpit windscreen for cockpit ventilation. H. H. Vogt states that the rear of the engine cowling bulges were shallower than on the Messerschmitt-built G-6/AS and G-14/AS. The Bf 109G-5/AS equipped with the Erlahaube cockpit canopy was no longer pressurized, however, it cannot be ruled out that the functionality of the cockpit pressurization system was also maintained with this type of canopy. In any case, silica gel capsules were still installed in the glass of the canopy to help prevent fogging of the glass. Also documented on the Bf 109G-5/AS is a special cylindrical tank located on a hanger beneath the fuselage, which was probably part of the GM-1 system.

The first aircraft were delivered in April and May, 1944 (III./JG 1, I./JG 3, I./JG 5, II./JG 11), and these were followed by I./NJGr.10, II./JG 27, I./JG 1 and III./JG 300 in June and July, 1944.

### General features of the Bf 109G-6/AS

- 1 Wide engine cowl side panels with riveted semielliptical aerodynamic fairings to fuselage.
- 2 Radiator under the engine as on standard G-6, Type Fö 870
- 3 The use of the larger Fö 987 radiator is also recorded, with an Erla cover as on the G-10 Erla built in the 15x xxx and 49x xxx blocks.
- 4 Lower engine cowling minus bulge below the oil tank
- 5 Older aircraft with VDM 9-12087 propeller (as on standard G-6), later versions with larger VDM 9-12159 propeller with wider paddle blades (as on the G-10).
- 6 Smaller supercharger intake on the left side of the cowling, as on standard G-6, although some aircraft (later production or overhauled/repaired aircraft) were given the larger intake (as on the G-10).
- 7 Access cover to supercharger clutch oil pump on the right side of the engine cowl was in a lower position.
- 8 Oil filler cap cover on the left side of the nose in lower position
- 9 Tall tail, Type 1.
- 10 Short tailwheel (usually)
- 11 Cockpit canopy with sharp inside corners at the rear and with a small antenna mast on the fuselage behind the cockpit. Aircraft converted from standard G-6s had the mast on the canopy frame and a number of these were without a mast altogether.
- 12 The G-6/AS/y had a whip antenna associated with the FuG 16zy system below the fuselage (below the wing)
- 13 Small blade antenna for the FuG 25a IFF system below the fuselage behind the wing trailing edge.
- 14 Wing fairings over the wheel wells were of the small type, as on the G-6, with corresponding wheels.
- 15 Some Bf 109G-5s were converted to the G-5/AS, serial numbers 110 xxx. They were the same as the G-6/AS, but carried a special tank below the fuselage (associated with the GM-1?)
- 16 Most aircraft carried fuselage MG 151/20 cannons.
- 17 The covers on the 5th fuselage segment were a feature of the Bf 109G-6/AS/U4 with a MK 108 30 mm fuselage cannon. A total of 151 of them were converted from the Bf 109G-6/U4 built at WNF, of which one was built by Erla, 130 were made by Mimetall and twenty by Blohm & Voss.
- 18 The GM-1 system pressure cylinder filling neck cover was present on the Bf 109G-6/U2/AS. A total of 265 Bf 109G-6/U2 conversions were produced, of which 104 were performed by Erla, 98 by Mimetall and 63 by Blohm & Voss. In addition, 45 photo-reconnaissance Bf 109G-6/U2/R2/AS were also produced at Erla through conversion of Bf 109G-6/U2s.

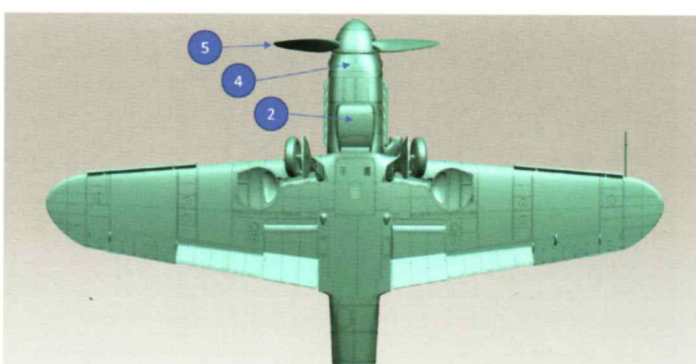
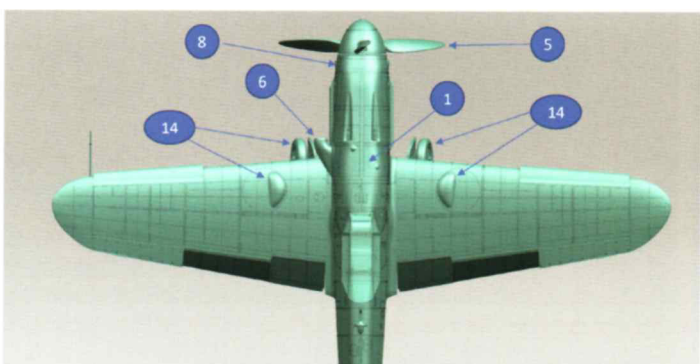
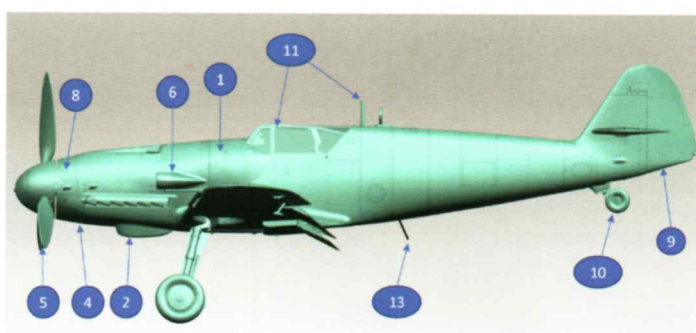
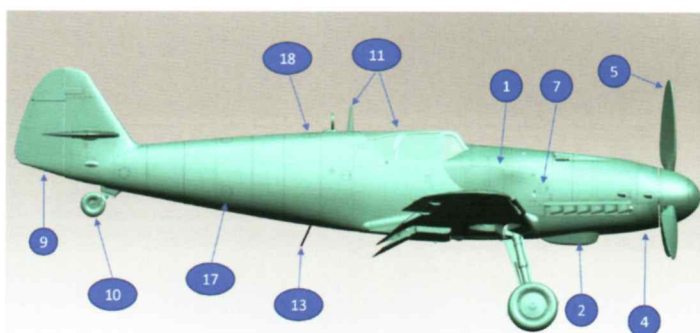



Original photograph of a Bf 109G-14/AS from the Messerschmitt Regensburg factory at the Salzburg-Maxglan base in June 1945.

Photo: National Archives

**Bf 109G-14/AS**

The production of the Bf 109G-6/AS was followed by the production of the Bf 109G-14/AS version, powered by the DB 605ASM engine and equipped, as standard, with a system for injecting a mixture of methanol and water into the intake of the MW 50 compressor. The installation of this system can be recognized by the box-shaped bulge on the rear wall cockpit, covering the battery, moved forward from its original position between the 1<sup>st</sup> and 2<sup>nd</sup> fuselage bulkheads for the installation of the MW 50 system tank. The DB 605ASM engine used 96 octane C3 gasoline as fuel. Another distinctive feature of the Bf 109G-14/AS was the standard installation of the FuG 16ZY direction finding system and its associated Morane-type whip antenna (Moranmast), still installed under the leading edge of the left wing. The FuG 25a IFF system was also standard. The Bf 109G-14/AS were produced as new at Messerschmitt and Erla. There is no evidence that they were purposely created by conversion from older Bf 109G-6 and G-14, but it is likely that parts of the airframes of older machines were used in their production. Airframes produced in production block 460 300 to 460 670 (50 units) by Erla had the smaller supercharger air intake and a smaller Fö 870 oil cooler as on the Bf 109G-6, and had an identical lower engine cowl, meaning they did not have fairings around the oil pumps on the bottom of the nose. Most machines from production block 461 100 to 461 999 (73 examples) then had the larger Fö 987 radiator, but with a specific fairing exclusive to Erla, which optically does

not appear as deep as the fairing of the same Bf 109G-10 radiator produced by Messerschmitt and WNF. The lower engine cowl of these aircraft thus corresponds to that of the later G-10 airframes coming out of Erla. The aircraft from Messerschmitt in Regensburg had, in addition to a few airframes from August 1944 production blocks 165 xxx and 166 xxx, a larger intake to the supercharger and a larger Fö 987 radiator (as the later G-10). Under the nose, two characteristic bulged fairings covering the oil pumps appeared for the first time. However, the nose oil tank remained of the small variety with the filler neck in a lower position just above the port suction pocket. The fin and rudder was of the tall variety. Later Messerschmitt production machines received rudders with a straight lower edge and three trims. The canopy was of the newer Erlahaube type with a rounded rear corner of the canopy frame and low antenna mast on the. The propeller was a VDM 9-12159 with wide blades. Some later aircraft received larger 660x190mm wheels, and with them large, elongated fairings on the upper surface of the wing. The tailwheel on the Erla aircraft (46x xxx) was short, and long on the Mtt. Regensburg version. The fill access cover to the supercharger clutch oil pump on the right side of the engine cowl was in a lower position, above the cowl fastener. Most, if not all aircraft had fuselage mounted MG 151/20 cannons. From the summer (July Erla, August Mtt) 1944 to the end of the year, around 1,400 Bf 109G-14/AS were produced, 123 of them at Erla and

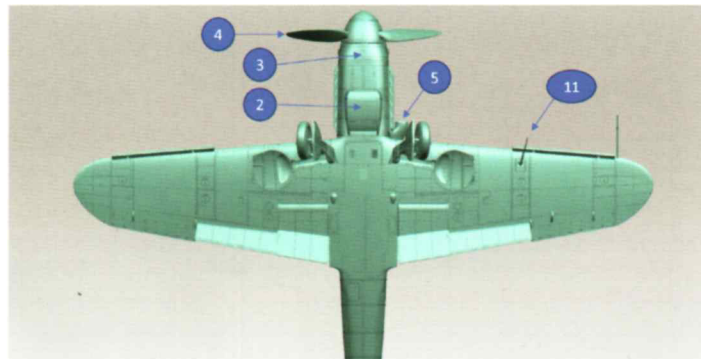
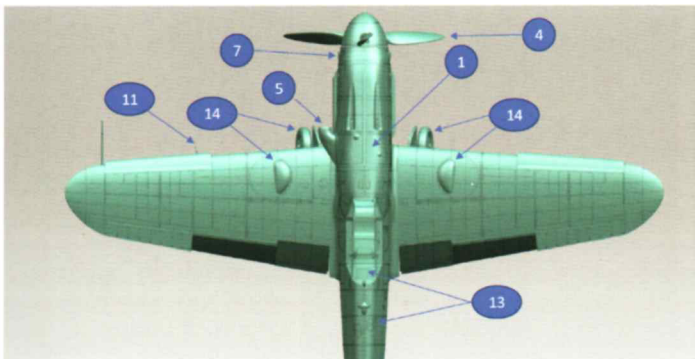
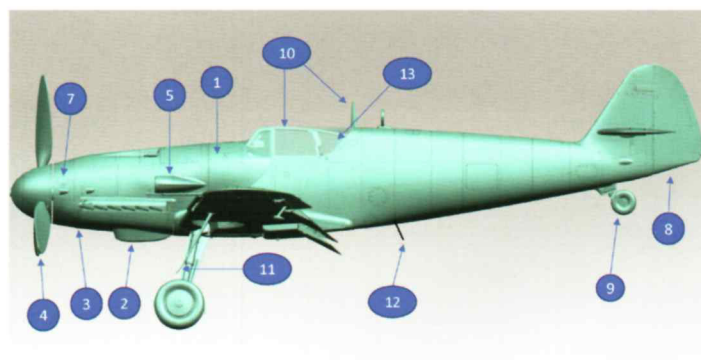
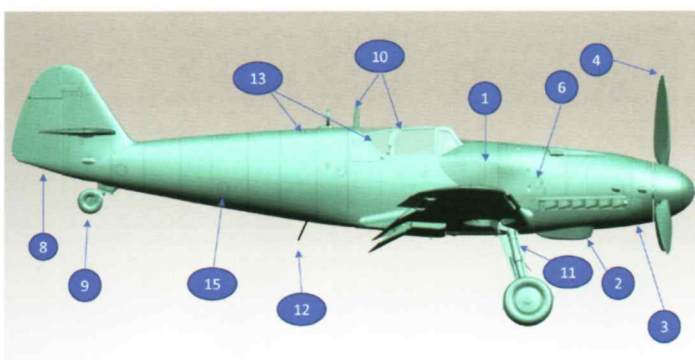

the rest at Messerschmitt. The date of the end of production of Bf 109G-14/AS at Messerschmitt is unclear. H. H. Vogt states that production ran until March, 1945. However, as early as October 1944, Bf109 G-10s from production block 130 xxx were on the assembly line, with which G-10 production at Regensburg ended, again according to H. H. Vogt, in December 1944, and which produced only 123 units. At the same time, from the end of August 1944, serial production of the Bf 109K-4 began. Of course, the completion of some Bf 109G-14/AS still early in

1945 cannot be completely ruled out. It should also be taken into account that the airframes of the Bf 109G-14/AS and the Bf 109G-10 from Regensburg were practically identical, the production of G-14/AS and G-10 followed each other immediately. Some of the few G-10s produced are said to have been fitted with DB 605ASM engines and designated Bf 109G-10/AS. There is some logic to be found in these largely conflicting timings, but it is probably wisest to close the matter with the understanding that it is very complicated at best.

### The Rudders

In the descriptions of the individual versions, there is often mention made of the various types of tails. These numbers are Eduard interim designations, and in the article, they describe the following types of rudders:

**Type 1** the first type of production rudder. It was made of a metal framework, covered with fabric. There was also a wooden version, often with an additional trim tab in the upper section (Type 2)

**Type 6** A deeper rudder of wooden construction, covered in fabric, with three trim tabs and a straight bottom edge.

**Type 9** Similar to Type 6, with a deeper middle trim tab and a more pronounced position light fairing.

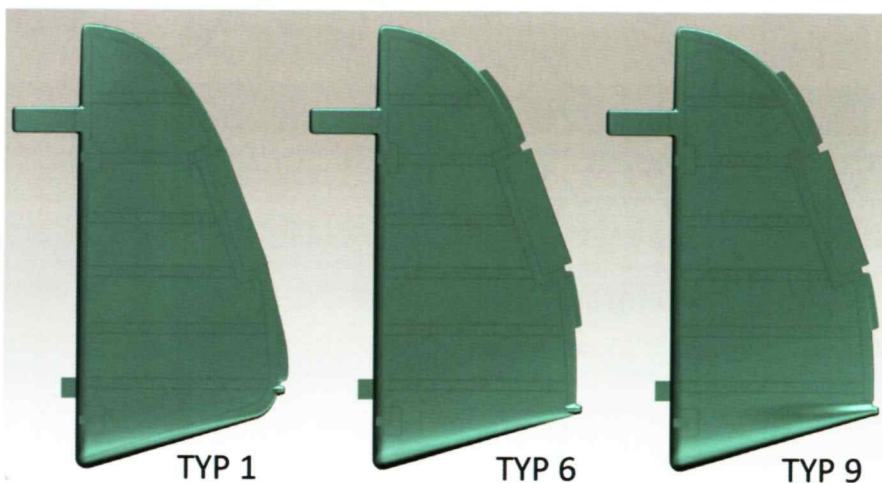
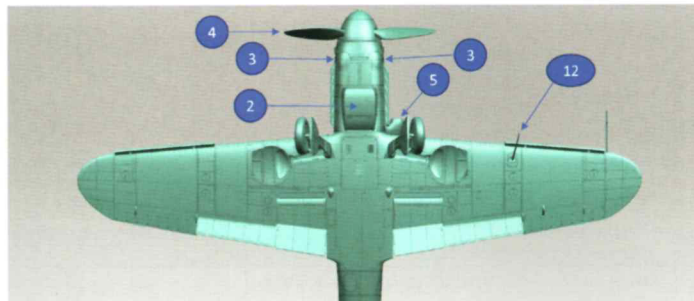
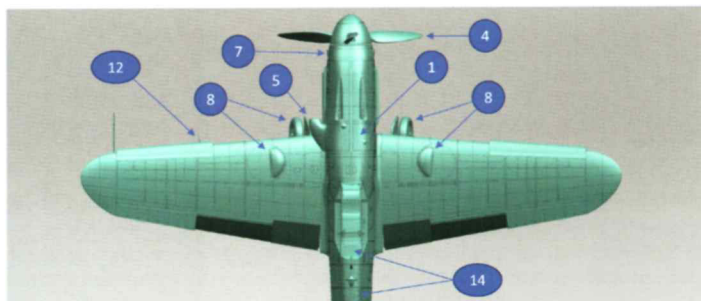
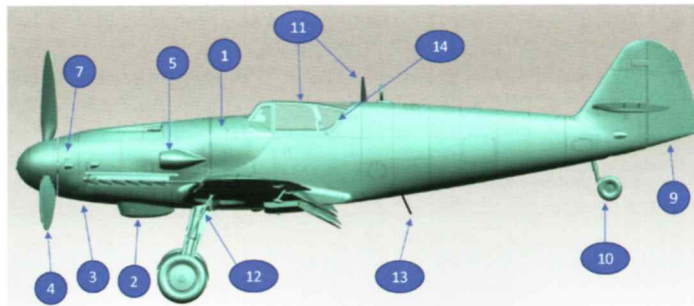
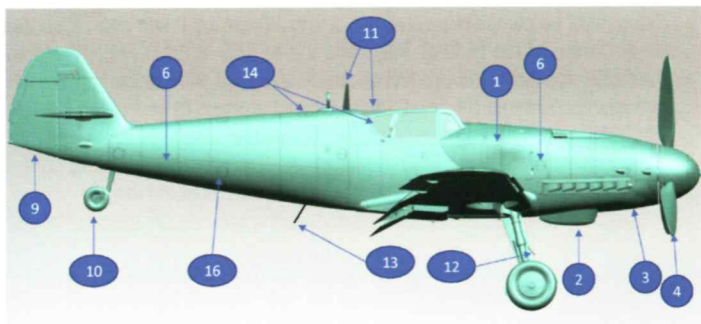

photo: Fold3

### General features of the Bf 109G-14/AS ERLA

Production Blocks 460 300 – 460 670

- 1 Wide engine cowl side panels with riveted semielliptical aerodynamic fairings to fuselage
- 2 Radiator under the engine as on standard G-6, Type Fö 870, though some aircraft received the larger Fö 987 unit with the same covering, as on the Erla G-10.
- 3 Lower engine cowling minus bulge below the oil tank
- 4 VDM 9-12159 propeller with wider paddle blades
- 5 Supercharger air intake on the left side of the cowling as on standard G-6, although some aircraft were given the larger intake as on the G-10.
- 6 Access cover to supercharger clutch oil pump on the right side of the engine cowl was in a lower position.
- 7 Oil filler cap cover on the left side of the nose in lower position
- 8 Tall tail, Type 1
- 9 Short tailwheel (usually)
- 10 Cockpit canopy with rounded inside corners at the rear and with an antenna mast on the canopy frame
- 11 A whip antenna associated with the FuG 16zy system was located under the left wing (protruding from a glass panel), as with the G-10.
- 12 Small blade antenna for the FuG 25a IFF system below the fuselage behind the wing trailing edge
- 13 MW 50 water-methanol injection system and its associated equipment, i.e. a box fairing on the rear wall of the cockpit behind the headrest, and an access panel on the right side of the spine behind the cockpit.
- 14 Wing fairings over the wheel wells were of the small type, as on the G-6, with corresponding wheels
- 15 Most aircraft were armed with fuselage mounted MG 151/20 cannons. The cover located in the fifth fuselage segment only appeared on aircraft with MK 108 30mm cannons mounted in the fuselage.



### General features of the Bf 109G-14/AS Mtt. Regensburg Mtt. Regensburg (Production Blocks 780 xxx to 787 xxx)

- 1** Wide engine cowl side panels with riveted semielliptical aerodynamic fairings to fuselage
- 2** Radiator under the engine was the larger Fo 987 as on the G-10
- 3** Lower cowling with bulges below oil tank
- 4** VDM 9-12159 propeller with wider paddle blades as on the G-10
- 5** Supercharger air intake on the left side of the cowling was of the larger type, as on the G-10.
- 6** Access cover to supercharger clutch oil pump on the right side of the engine cowl was in a lower position.
- 7** Oil filler cap cover on the left side of the nose in lower position
- 8** Small wheel well fairing on the upper wing as on the G-6, with corresponding wheels, with corresponding 660 x 0 160 wheels
- 9** Taller tail Type 6 or Type 9 (later aircraft)
- 10** Usually, a long tailwheel. Short one is documented in later production blocks.
- 11** Cockpit canopy with rounded inside corners at the rear and with an antenna mast on the fuselage behind the cockpit (usually)
- 12** A whip antenna associated with the FuG 16zy system was located under the left wing (protruding from a glass panel), as with the G-10.
- 13** Small blade antenna for the FuG 25a IFF system below the fuselage behind the wing trailing edge
- 14** MW50 water-methanol injection system and its associated equipment, i.e., a box fairing on the rear wall of the cockpit behind the headrest and an access panel on the right side of the spine behind the cockpit
- 15** A number of aircraft manufactured at the end of 1944 got DB 605D engine.
- 16** Most aircraft were armed with fuselage mounted MG 151/20 cannons. The cover located in the fifth fuselage segment only appeared on aircraft with MK 108 30mm cannons mounted in the fuselage.

### The Boost Systems

The GM-1 (for which Göring Mischung 1 and Ha-ha Gerät were slang terms) system injected nitrous oxide into the engine pistons. With the DB 605AS engine, its use was permitted at an altitude of 10,000 m and climbing, and from 10,500 m in level flight. In the DB 605A, use was permitted in a climb from 8,000 m. The GM-1 system could be used for between 11 and 22 minutes, depending on the time of year, outside temperature and time since filling the system.

For increasing engine performance at altitudes up to 6,000 m, a methanol-water supercharger intake injection system was used in the form of MW 50 (methanol/water 50:50, as the designation suggests equal parts of methanol and water, plus 0.5% Schutzöl 39, an anti-corrosion additive). There variations on the MW 50 theme, designated by the mixture: MW 30 (methanol/water at 70:30), EW 50 (ethanol/water 50:50) and EW 30 (ethanol/water 70:30). The MW 50 system was able to increase engine performance by 20% to 25%, depending on altitude and other relevant conditions. Its use was permitted to a maximum of twice for ten minutes during a single flight (other sources differ on these values, such as a maximum length of time of use of 5 minutes). At altitudes over 6,000 m, the effectiveness of the system fell off dramatically, and is said that it only provided a 4% increase in performance above 6,000 m.

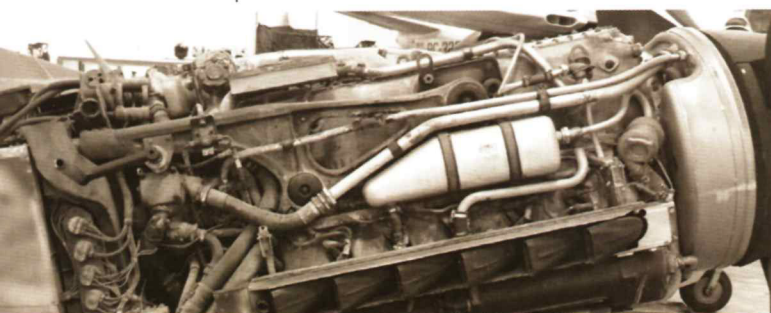

The differences in the GM-1 and MW 50 systems did not include, as is sometimes claimed, a lower usefulness or obsolescence of the GM-1 compared to the MW 50. In practical terms, there was no replacement of one by the other. Each was technically different and was intended for use under different conditions, although both worked on the principle of internal cooling of the engine combustion chambers.

The MW 50 worked by lowering the temperature by injecting water into the supercharger, and so also the volume of compressed air on entering it, which allowed an increase in air (oxygen) content of the fuel/air mix that was injected into the cylinders. The system was, of course, dependant on the local air pressure to begin with, and at higher altitudes, the effectiveness dropped off simply because in thin air, there was less oxygen.

With the GM-1 system, nitrous oxide was injected into the cylinders, which, under high temperatures, broke down into nitrogen and oxygen. The nitrogen lowered the temperature of the mix and its volume in the cylinder, which, in turn, allowed a higher amount of the gas, and the oxygen supported combustion. As a result, the GM1 system was not dependant on the outside air pressure, and that's why it was intended for use at higher altitudes (the minimum alt. for its use in the DB 605D was 10,000 m). The more widespread use of the MW 50 system and its basically standard installation in the Bf 109G-14, G-14/AS and G-10 was dictated by the tactical conditions that prevailed over the European battlegrounds, where most air combat took place at low and middle altitudes, below or up to 6,000 m. The GM-1 system was utilized for specific tasks at high altitudes, during reconnaissance flights and fighters.

Installation of the GM-1 in the Bf 109 was indicated by the suffix U2, and with the MW 50, by U3. That means that the, for example, Bf 109G-6/AS/U2 or Bf 109 G-6/U2/AS was a Bf 109G-6 airframe powered by the DB 605AS and carried the GM1 system. Both systems were used not only in connection with the DB 605, but with other types of German engines as well, such as the BMW 801.

ATTENTION

UPOZORNĚNÍ

ACHTUNG

ATTENTION

注意



Carefully read instruction sheet before assembling. When you use glue or paint, do not use near open flame and use in well ventilated room. Keep out of reach of small children. Children must not be allowed to suck any part, or pull vinyl bag over the head.



Před započítím stavby si pečlivě prostudujte stavební návod. Při používání barev a lepidla pracujte v dobře větrané místnosti. Lepidla ani barvy nepoužívejte v blízkosti otevřeného ohně. Model není určen malým dětem, mohlo by dojít k požití drobných dílů.

INSTRUCTION SIGNS \* INSTR. SYMBOLS \* INSTRUKTION SINNBILDEN \* SYMBOLES \* 記号の説明

-   
 OPTIONAL  
VOLBA
-   
 BEND  
OHNOUT
-   
 SAND  
BROUSIT
-   
 OPEN HOLE  
VYVRTAT OTVOR
-   
 SYMETRICAL ASSEMBLY  
SYMETRICKÁ MONTÁŽ
-   
 REMOVE  
ODŘÍZNOUT
-   
 REVERSE SIDE  
OTOČIT
-   
 APPLY EDUARD MASK  
AND PAINT  
POUŽÍT EDUARD MASK  
NABARVIT

**PLEASE, CHECK THE LATEST VERSION OF THE INSTRUCTIONS ON [www.eduard.com](http://www.eduard.com)**

PARTS

DÍLY

TEILE

PIÈCES

部品

S>

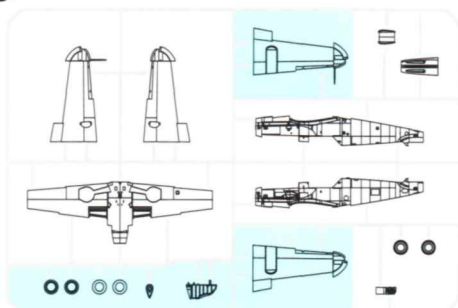

P>

PLASTIC PARTS

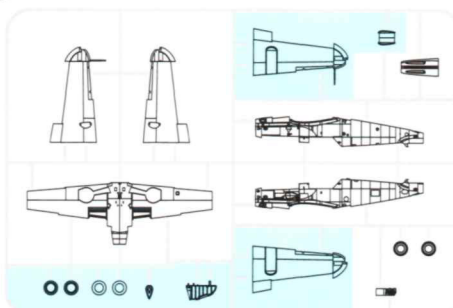

J> 2 pcs.

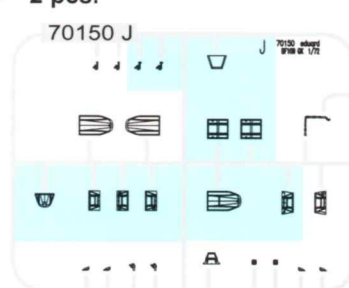

U>2 pcs.

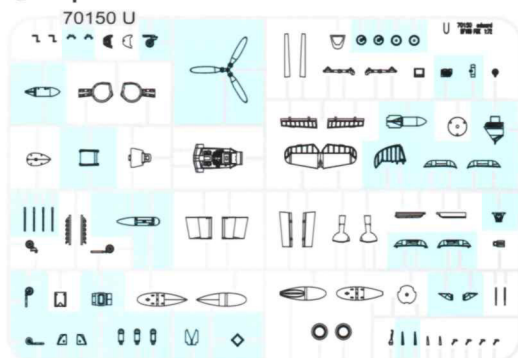

V> 2 pcs.

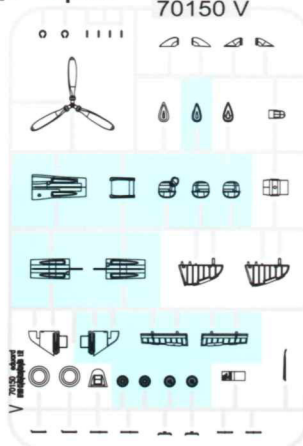

PE - PHOTO ETCHED DETAIL PARTS  
2 pcs.

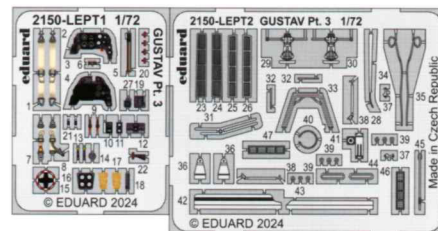

eduard  
MASK



-Parts not for use. -Teile werden nicht verwendet. -Pièces à ne pas utiliser. -Tyto díly nepoužívejte při stavbě. - 使用しない部品

COLOURS

BARVY

FARBEN

PEINTURE

色

GSI Creos (GUNZE)		
AQUEOUS	Mr.COLOR	
H2	C2	BLACK
H11	C62	FLAT WHITE
H12	C33	FLAT BLACK
H65	C18	RLM70 BLACK GREEN
H68	C36	RLM74 DARK GRAY
H69	C37	RLM75 GRAY
H70	C60	RLM02 GRAY
H74	C26	GREEN BLUE
H77	C137	TIRE BLACK
H90	C47	CLEAR RED
H94	C138	CLEAR GREEN
H319	C319	LIGHT GREEN
H324	C324	LIGHT GRAY
H413	C113	RLM04 YELLOW
H414	C114	RLM23 RED

GSI Creos (GUNZE)		
AQUEOUS	Mr.COLOR	
H416	C116	RLM66 BLACK GRAY
H417	C117	RLM76 LIGHT BLUE
H421	C121	RLM81 BROWN VIOLET
H422	C122	RLM82 LIGHT GREEN
Mr.METAL COLOR		
MC213		STEEL
MC214		DARK IRON
MC218		ALUMINIUM
MC219		BRASS
Mr.COLOR SUPER METALLIC		
SM201		SUPER FINE SILVER
Mr.COLOR GX		
GX05		SUSIE BLUE



S7, S15 - MARKINGS **A B C D E**

P7, P15 - MARKINGS **F G H I J**

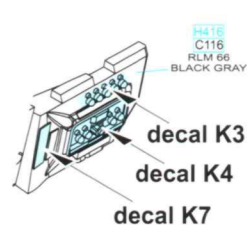
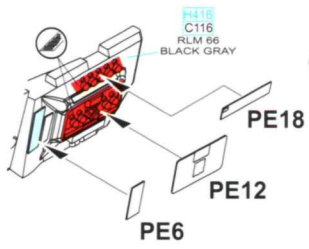
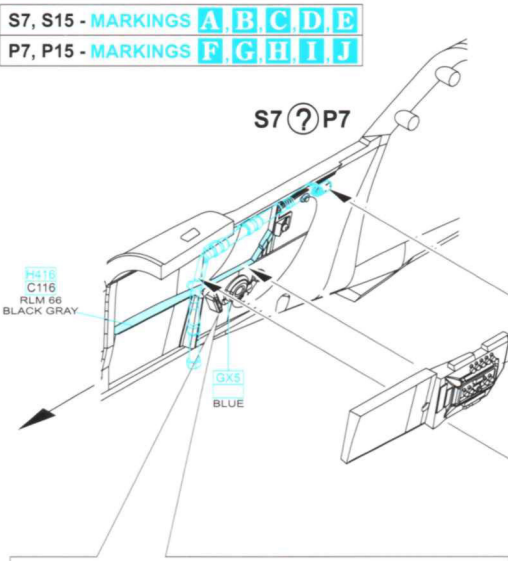

S8 - MARKINGS **A B C D E**

P8 - MARKINGS **F G H I J**

S8 ? P8

S15 ? P15

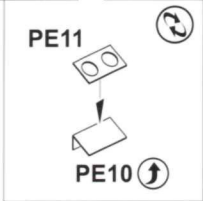
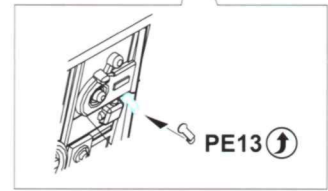
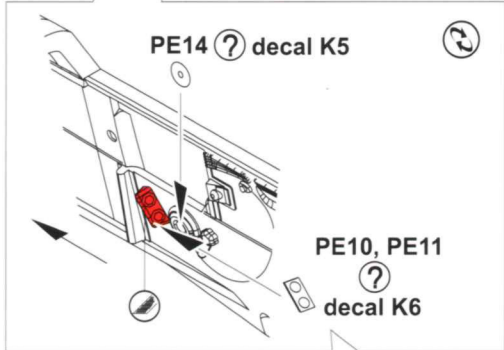
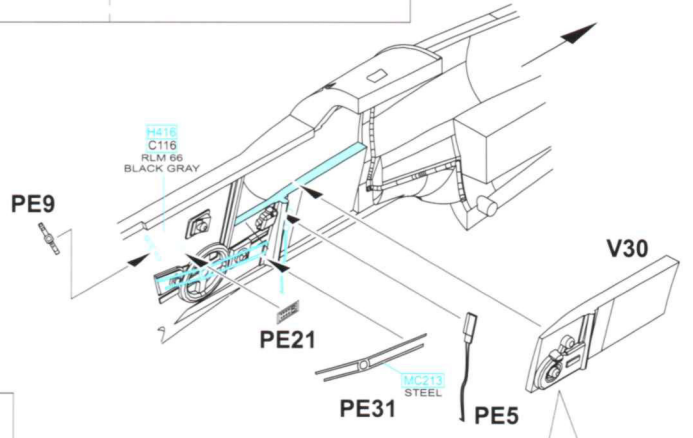

step 1

S7 ? P7

step 2

S7, S8 - MARKINGS **A B C D E**

P7, P8 - MARKINGS **F G H I J**

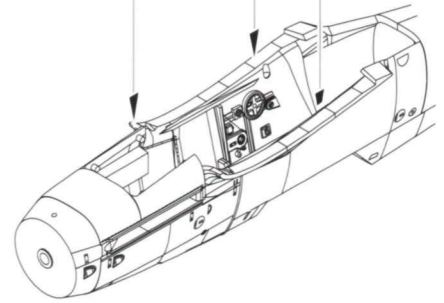
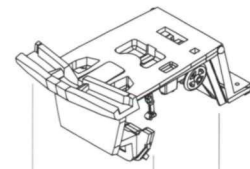
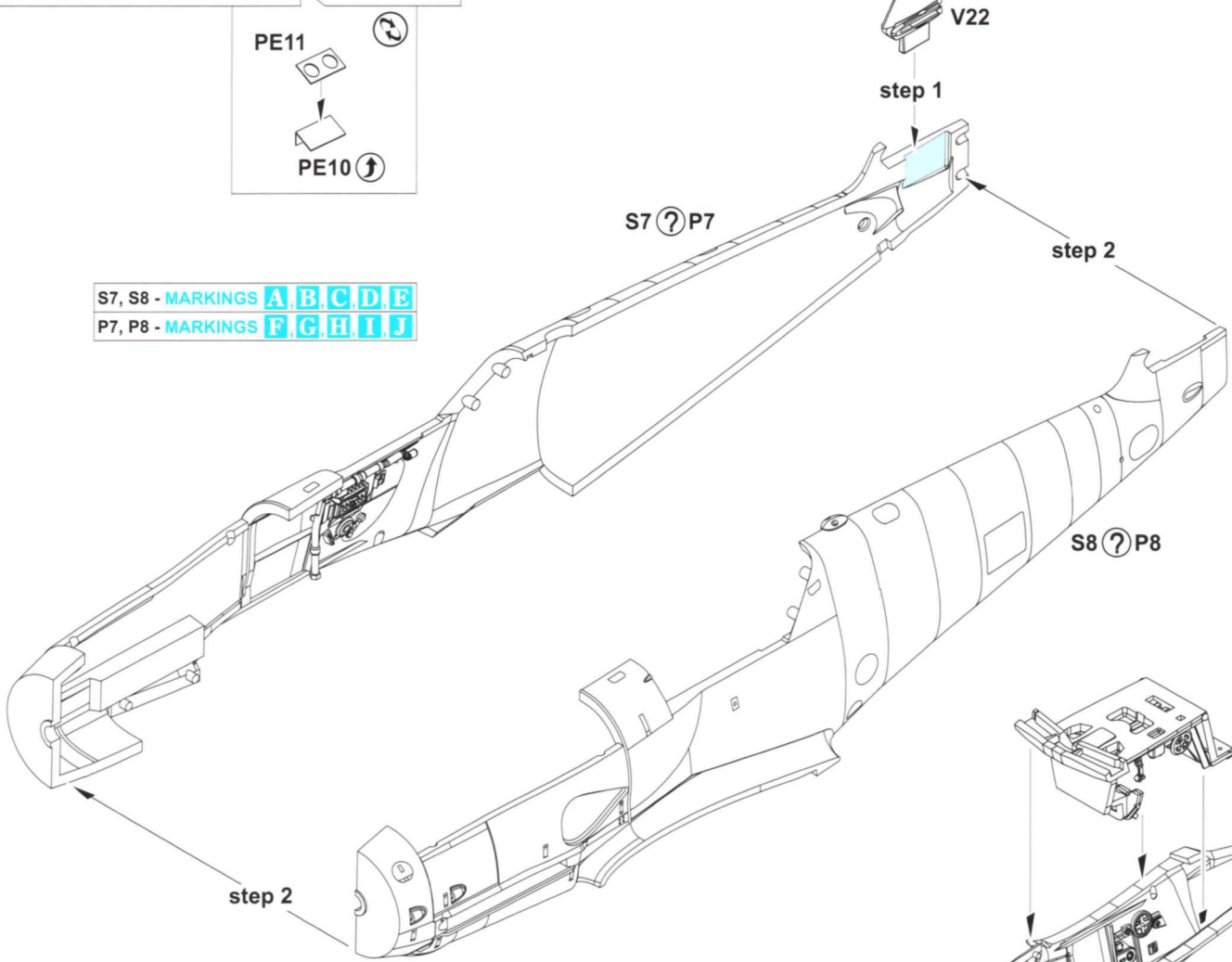

U7 - MARKINGS B,C,D

V27 - MARKINGS A,E,F,G,H,I,J

S6 - MARKINGS A,B,C,D,E

P6 - MARKINGS F,G,H,I,J

P6  
?  
S6

U7  
?  
V27

H416  
C116  
RLM 66  
BLACK GRAY

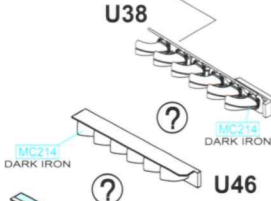
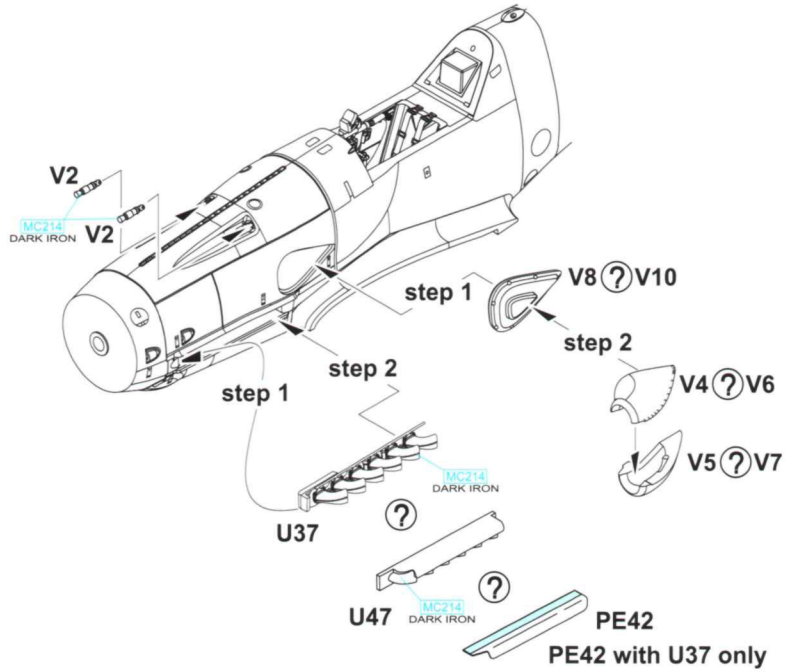
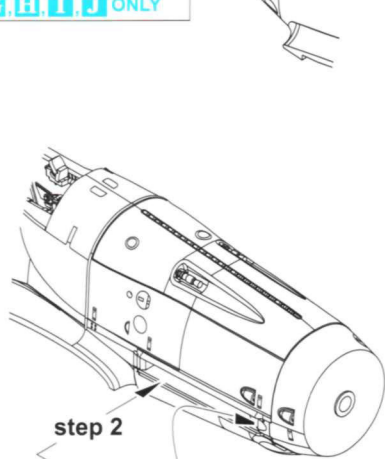
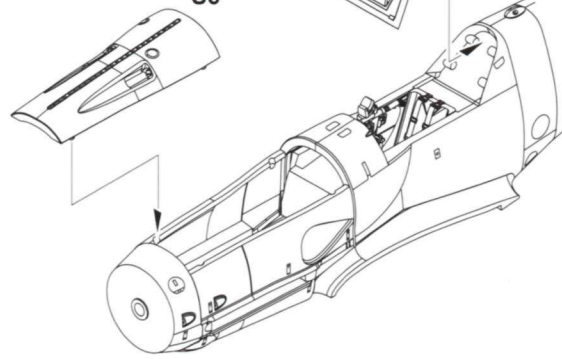
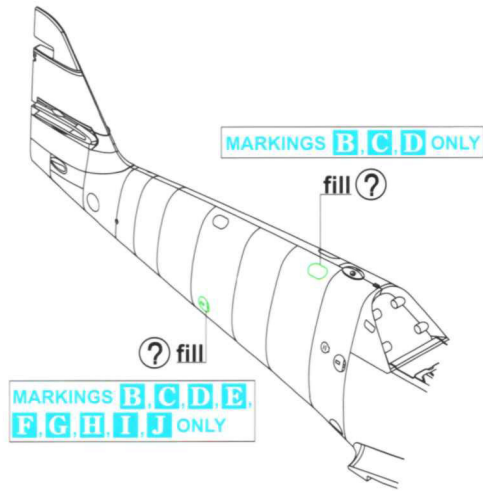

PE43  
PE43 with U38 only

V6, V7, V10 - MARKINGS A,B,C,D,E

V4, V5, V8 - MARKINGS F,G,H,I,J

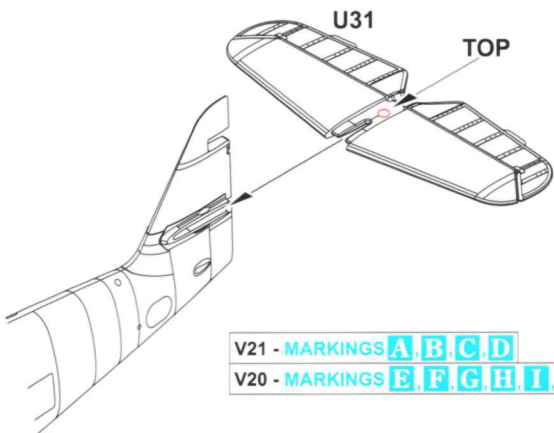

V21 - MARKINGS A,B,C,D  
V20 - MARKINGS E,F,G,H,I,J

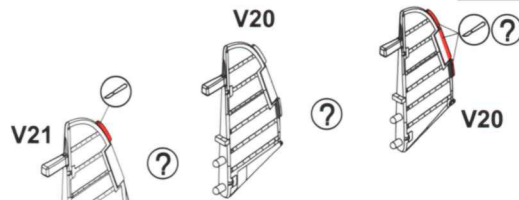

MARKINGS F, I ONLY

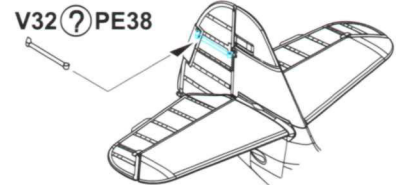

H77  
C137  
TIRE BLACK

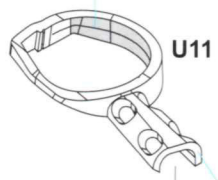

U11

H73  
C60  
RLM 02  
GRAY

U12

H77  
C137  
TIRE BLACK



P1 ? S1

S1, S2, S3 - MARKINGS **A B C D E**

P1, P2, P3 - MARKINGS **F G H I J**

∅ - 0,6 mm ?

CENTRAL RACK

MARKINGS **C D E F G H I J** ONLY

J19

P3 ? S3

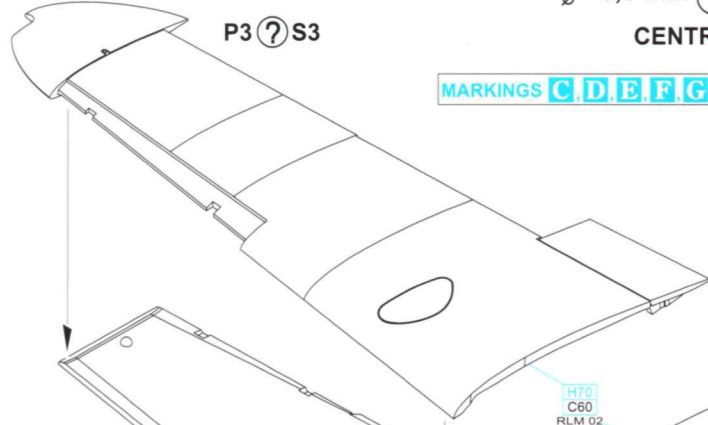

H73  
C60  
RLM 02  
GRAY

P2 ? S2

P1 ? S1

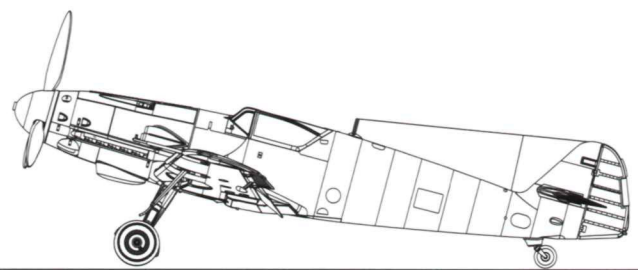
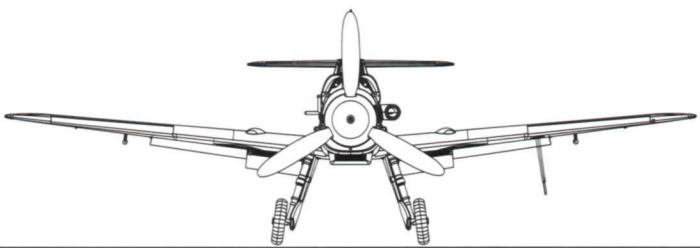

# CLOSE

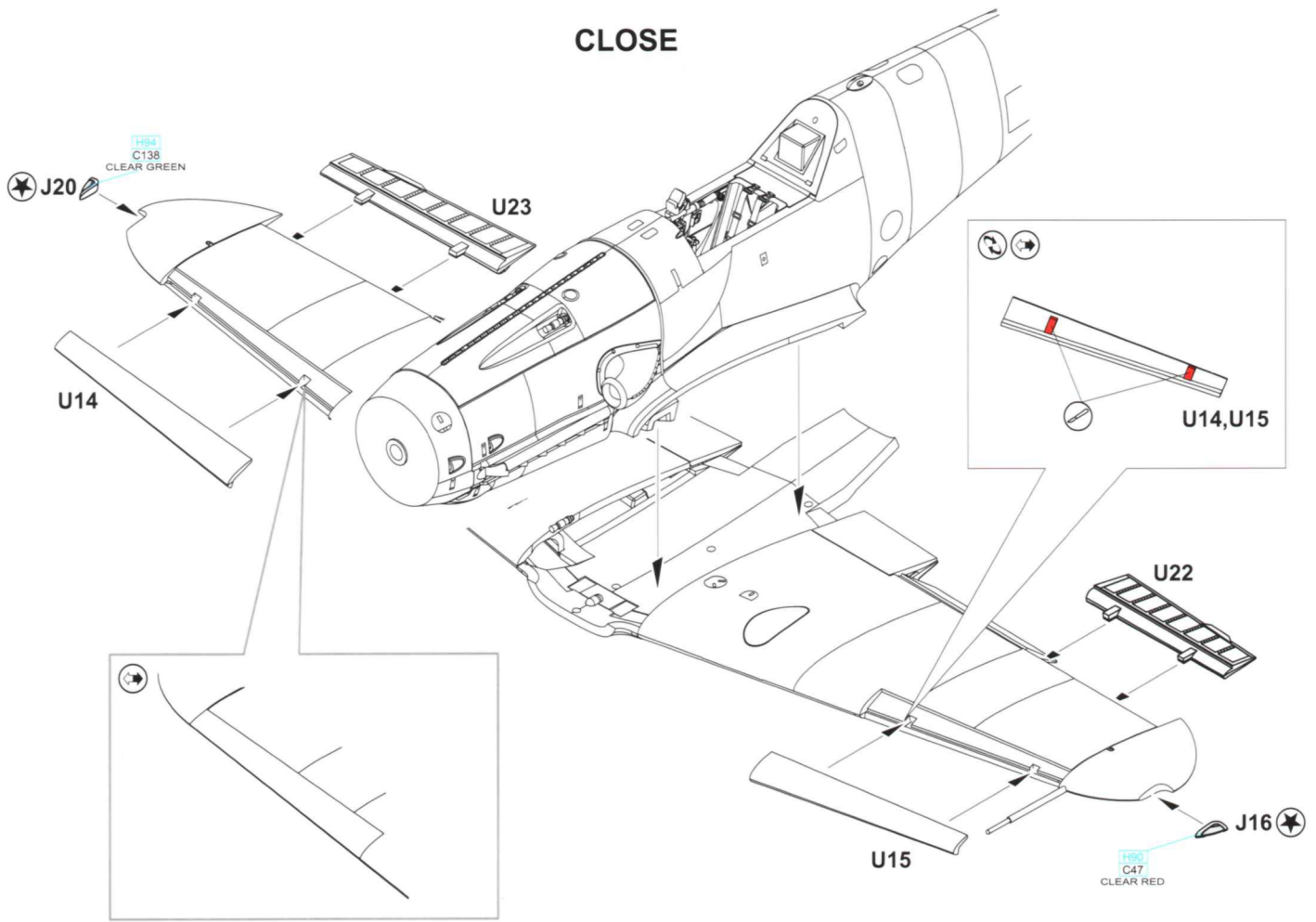

# OPEN

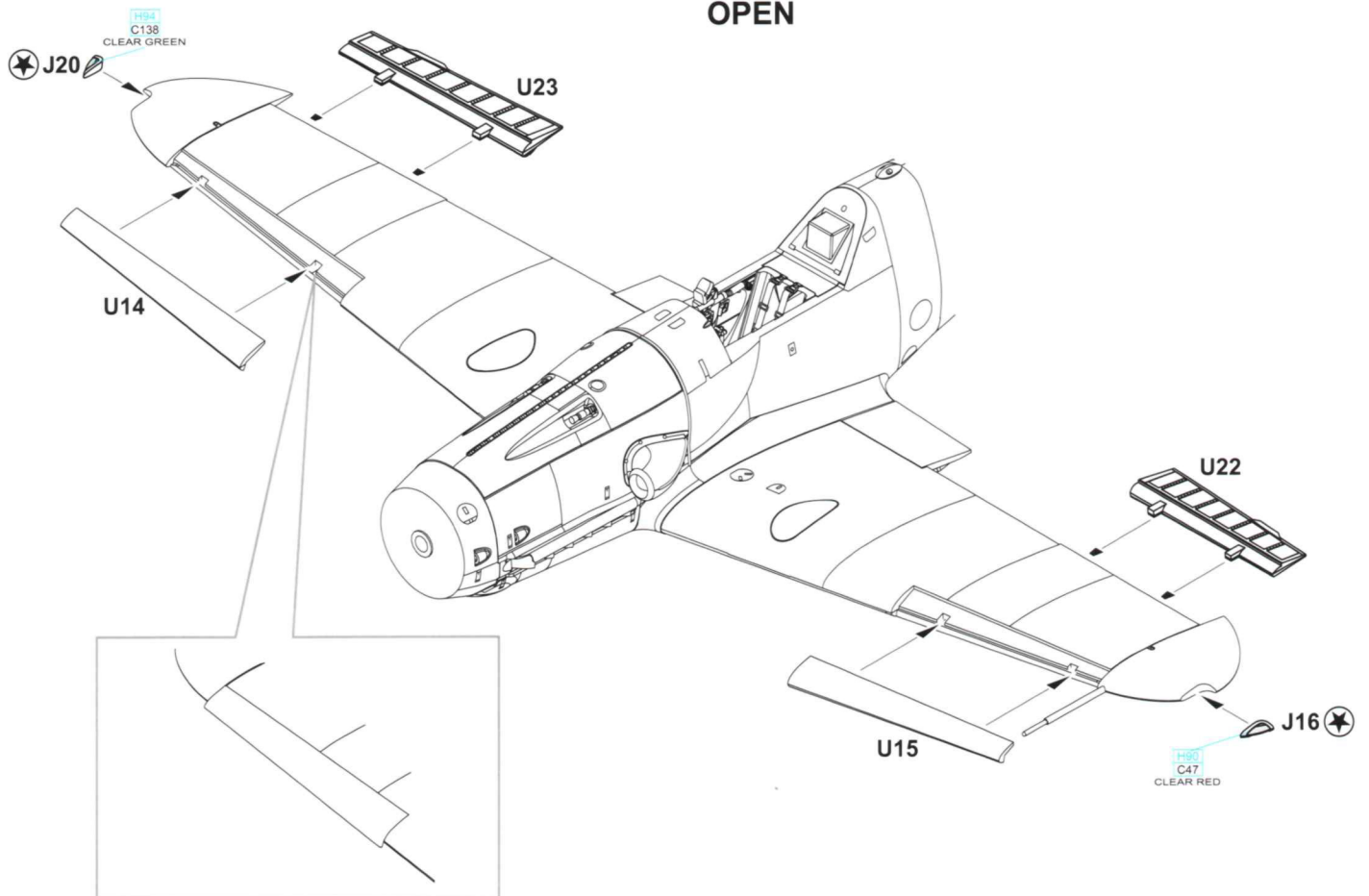

FRONT VIEW

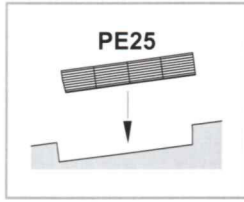

U40

?

U41

?

MC214  
DARK IRON

PE23

PE25

MC214  
DARK IRON

MC214  
DARK IRON

PE26

?

MC214  
DARK IRON

PE24

?

H70  
C60  
RLM 02  
GRAY

H70  
C60  
RLM 02  
GRAY

S5 - MARKINGS **A, B, C, D, E** ONLY

S5 ? V13

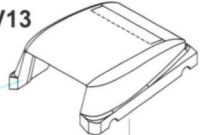

H70  
C60  
RLM 02  
GRAY

PE47

MC214  
DARK IRON

PE46

MC214  
DARK IRON

V17

H70  
C60  
RLM 02  
GRAY

FRONT VIEW

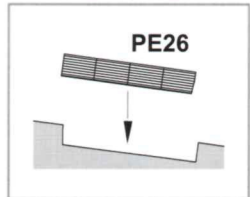

PE26

fill ?

MARKINGS **A, B, C, D** ONLY

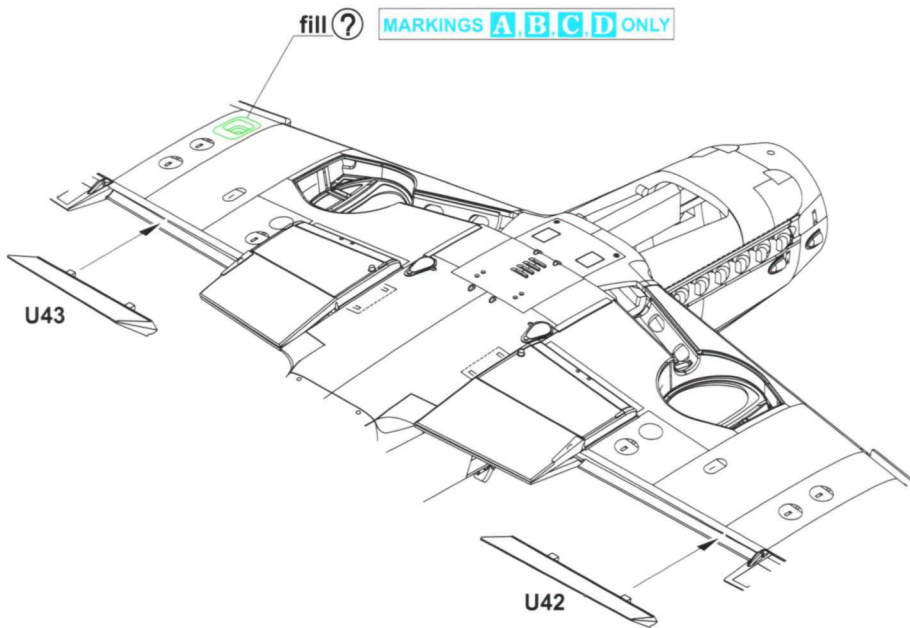

U43

U42

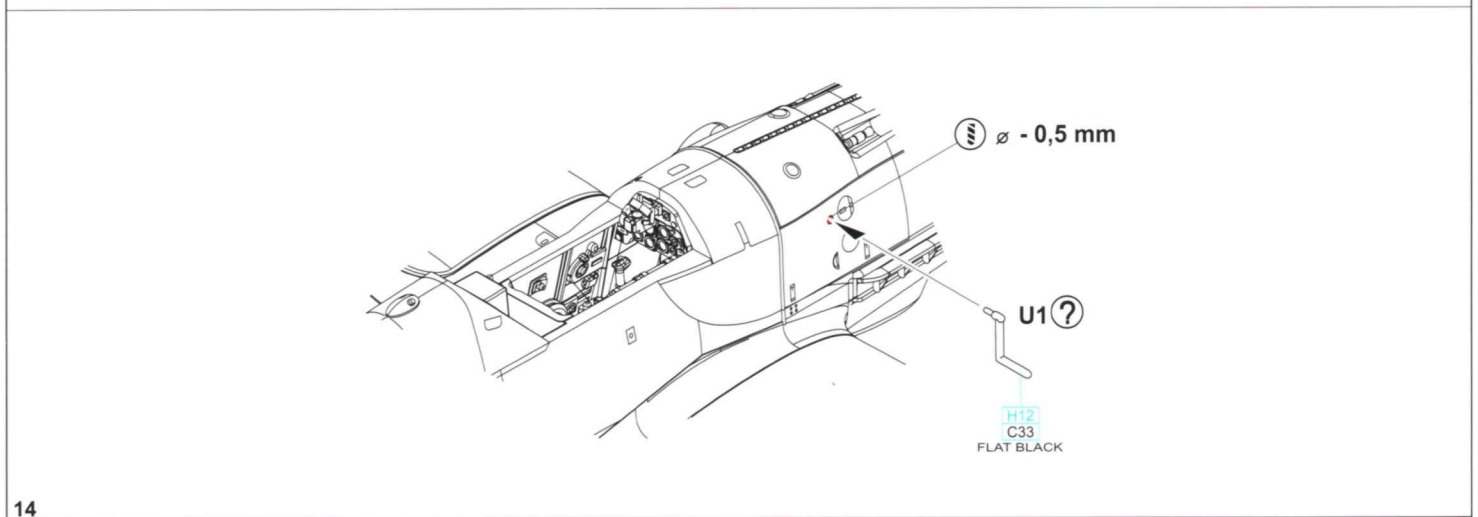
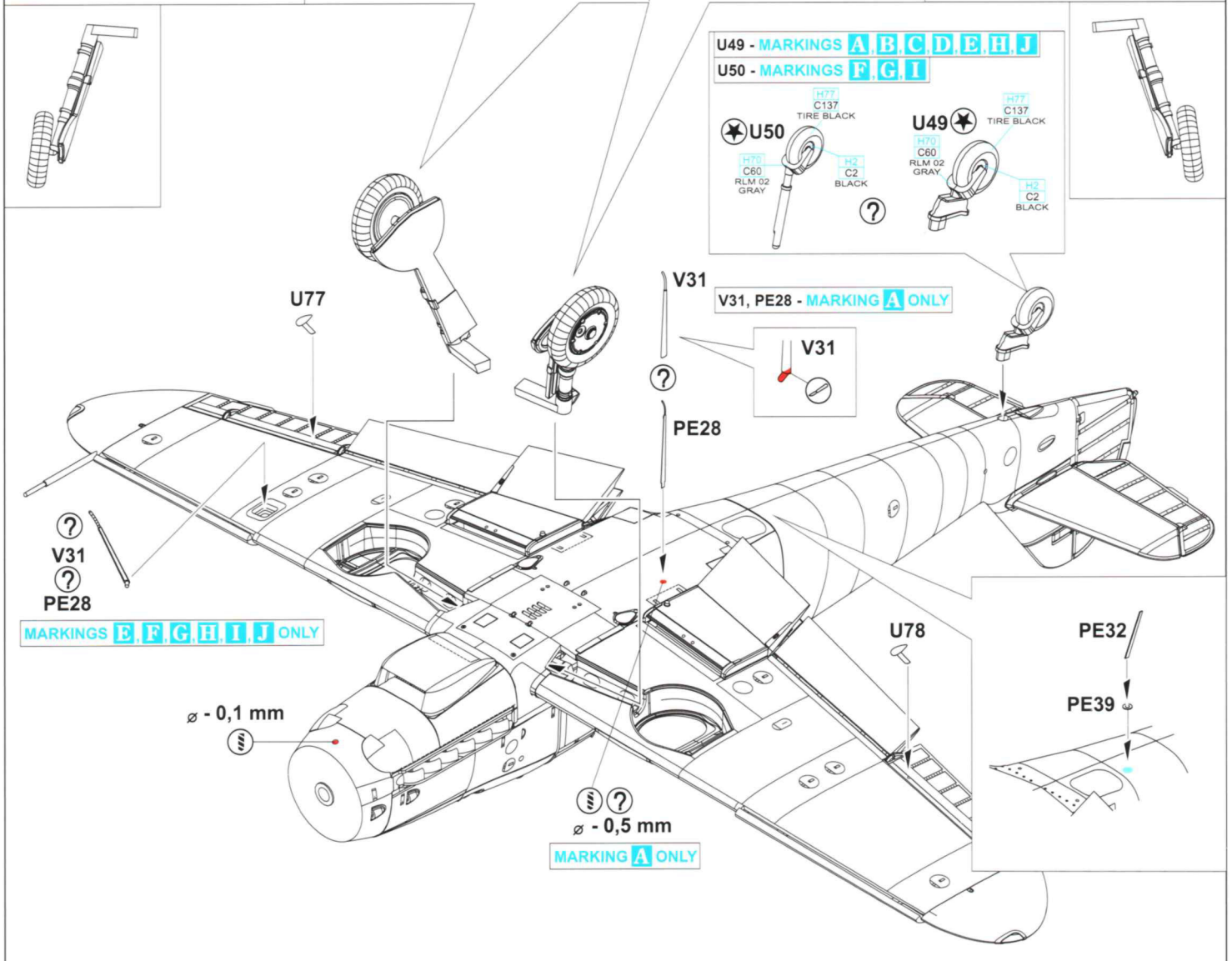
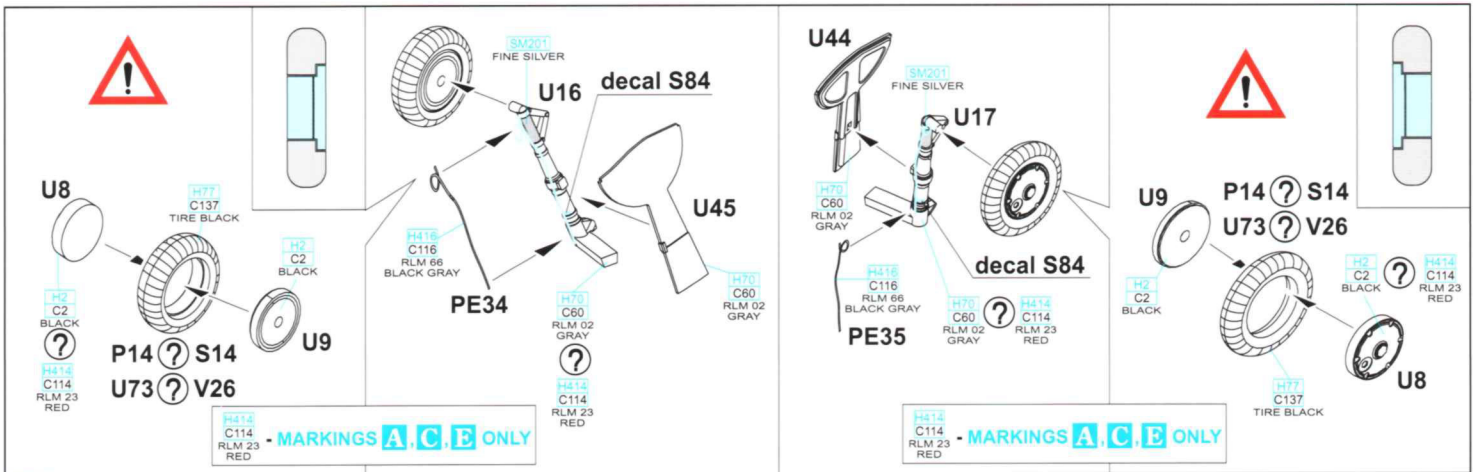

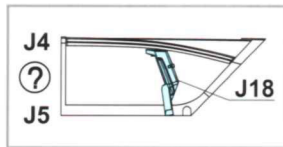
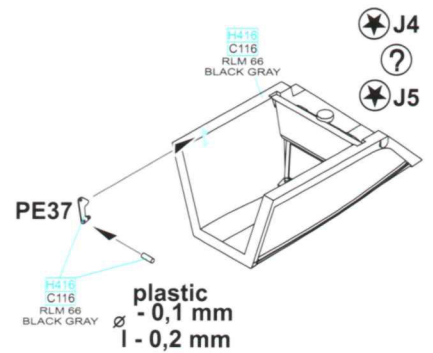
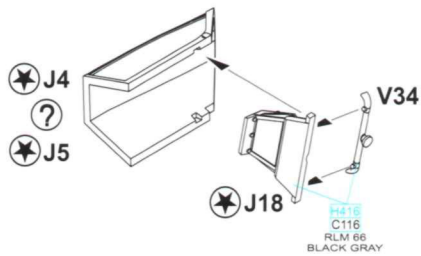
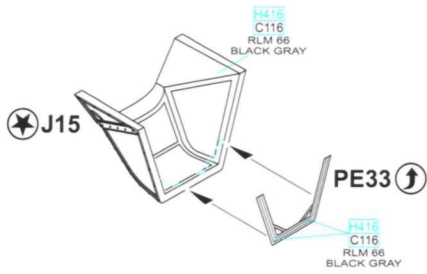

J5 - MARKINGS **A,C**  
 J4 - MARKINGS **B,D,E,F,G,H,I,J**

MARKINGS **A,B,D,E,F,G,H,I,J** ONLY

MARKINGS **A,C** ONLY

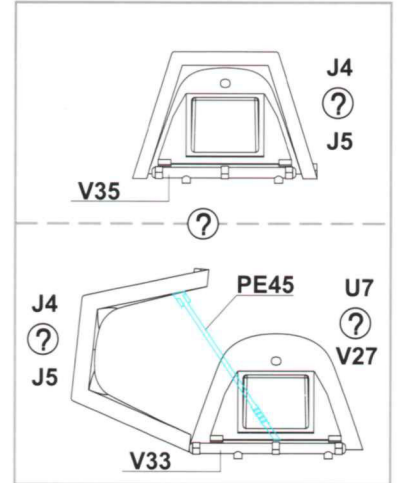
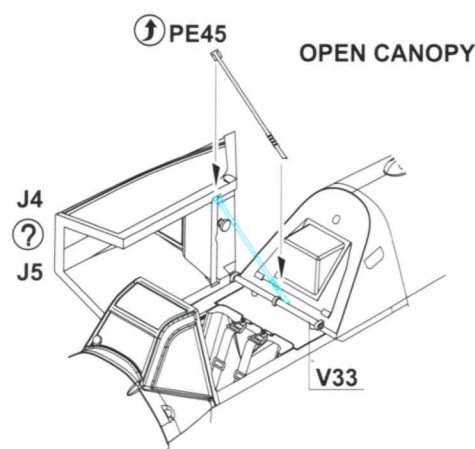
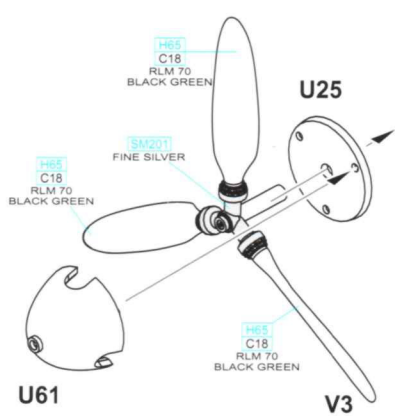
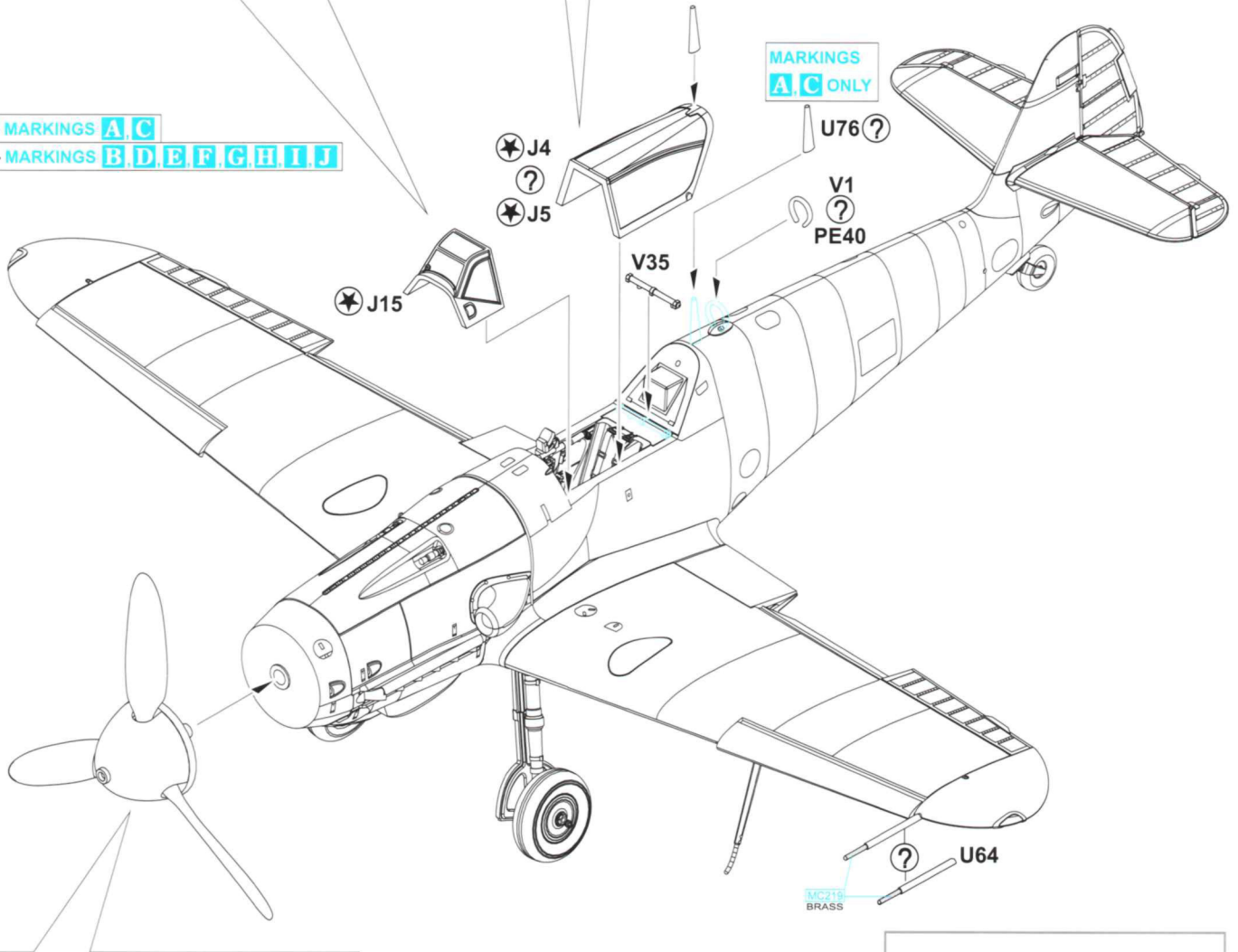

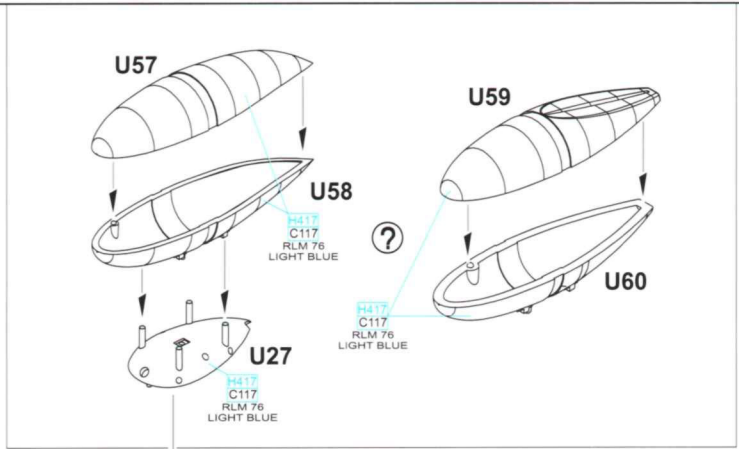

MARKINGS C, D, E, F, G, H, I, J ONLY

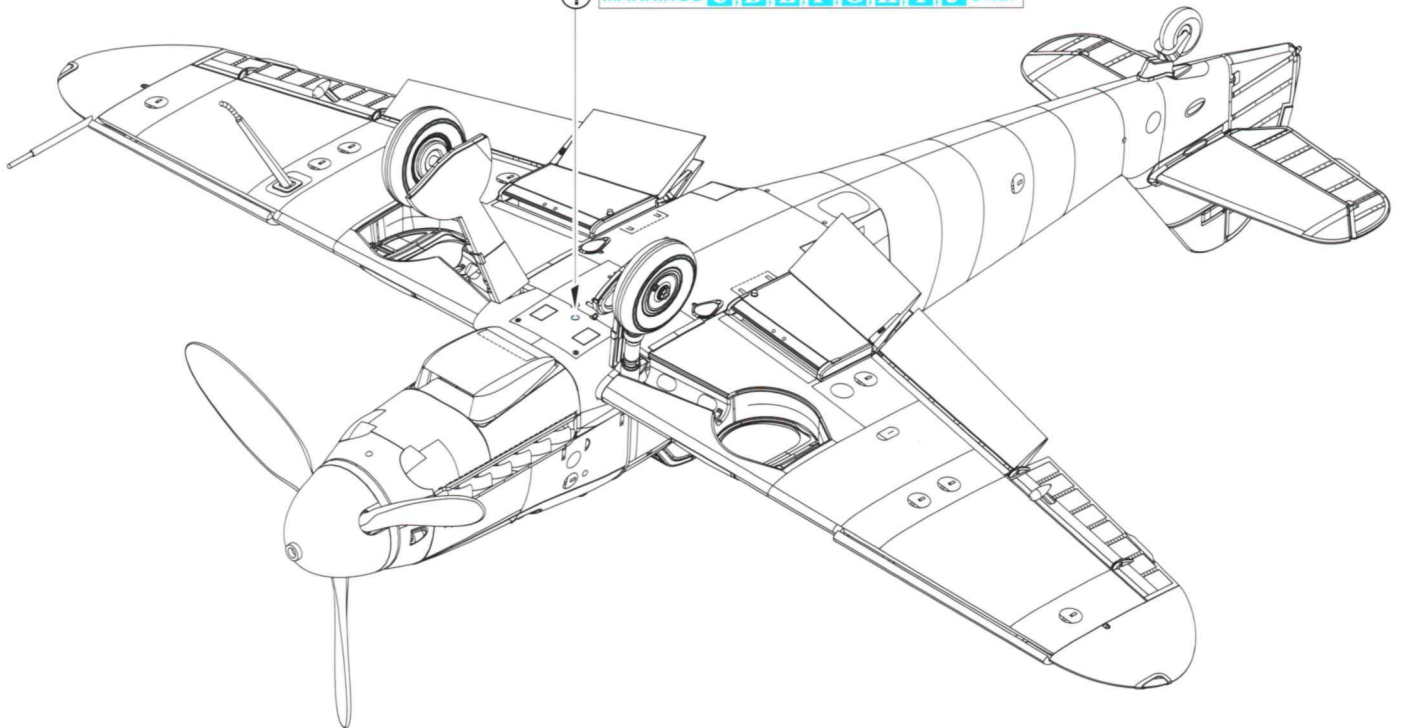

eduard  
MASK  
2150

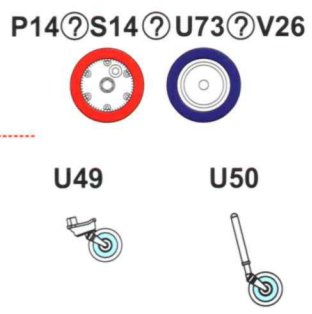
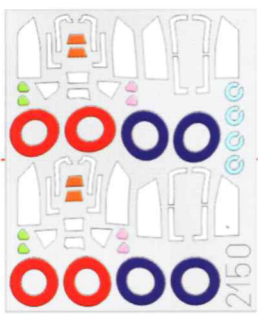
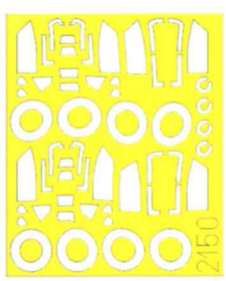
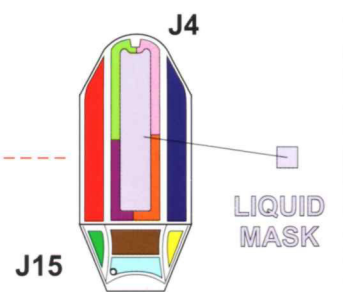
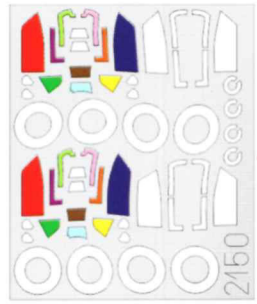
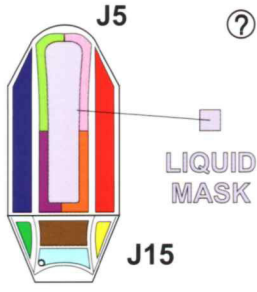
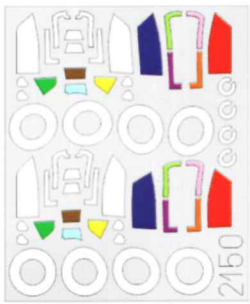



# B Bf 109G-6/AS, Hptm. Friedrich-Karl Müller, CO of 1./NJGr. 10, Werneuchen, Germany, July 1944

Friedrich-Karl Müller, the future Knight's Cross recipient and the ace with thirty night victories over the enemy aircraft, was born on December 4, 1912, in Sulzbach, Saarland. In 1934 he completed his pilot training and got the job with Lufthansa. After the outbreak of World War II, he was transferred to the Luftwaffe. Initially, he was flying as a transport pilot, later as an instrument flying instructor. In December 1942, he was assigned to KG 50 flying with He 177s and in the summer of the following year he responded to Hajo Hermann call and requested the reassignment to JG 300 famous for its Wilde Sau (single-engine fighter night interception without airborne radar guidance) tactics. While serving with this unit, Müller was credited with 19 victories and in January 1944 he was ordered to Forem 1./NJGr. 10. In August 1944, he was promoted to command 1./NJG 11 and was leading this unit until the end of World War II. He passed away on November 2, 1987. The bottom surfaces and part of sides were painted black to better suit night conditions. The red band around rear fuselage indicated the original operator of this aircraft within the Reich Defense system was JG 300. The kill marks were painted on left side of the rudder in the form of the twenty-three stripes with cockades appropriate to the victim nationality and date of the victory.

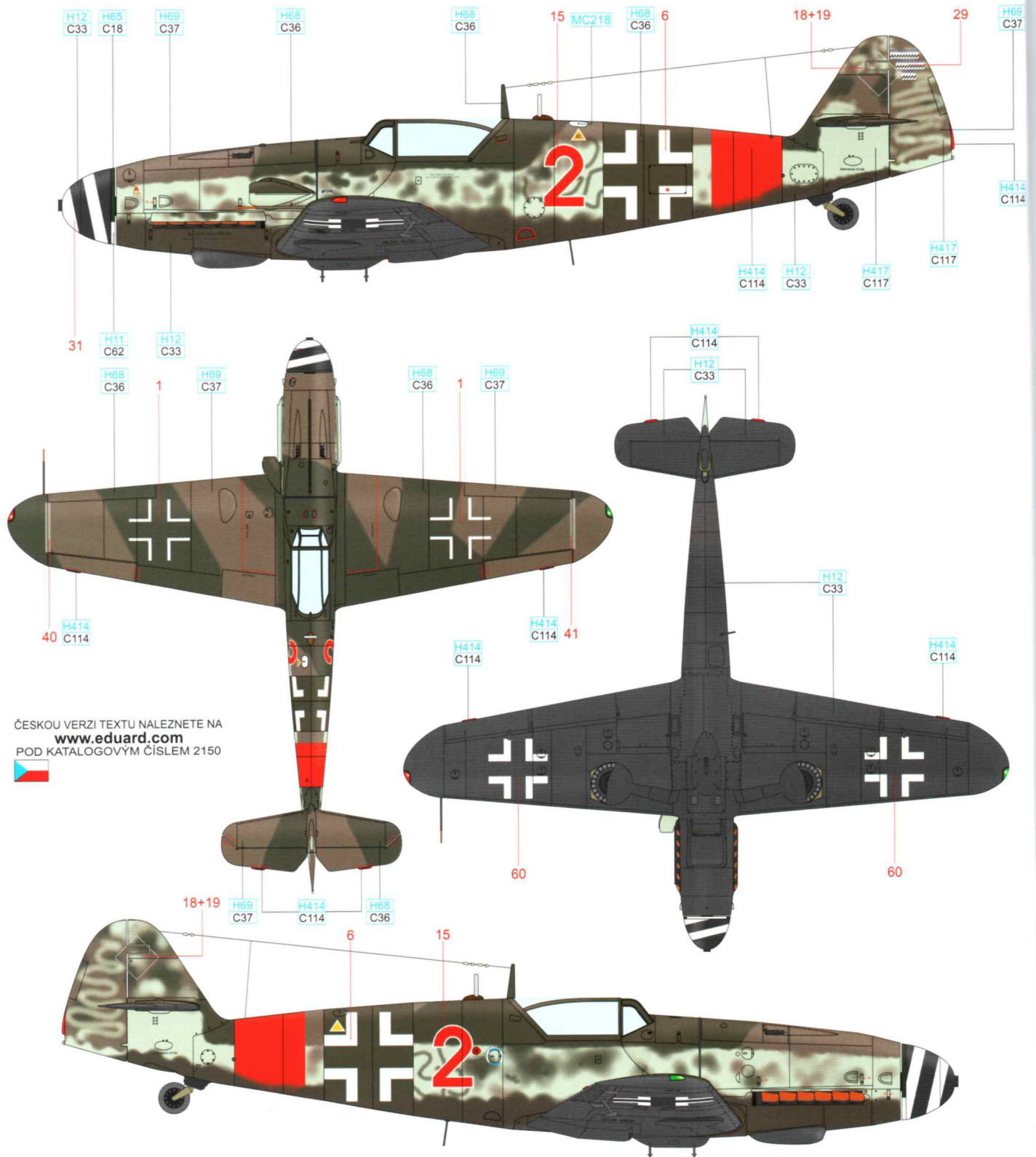

ČESKOU VERZI TEXTU NALEZNETE NA  
[www.eduard.com](http://www.eduard.com)  
 POD KATALOGOVÝM ČÍSLEM 2150



ALUMINIUM MC218

WHITE H11 C62 RLM 76 H417 C117 RLM 75 H69 C37 RLM 74 H68 C36 RLM 70 H65 C18 RLM 23 H414 C114 FLAT BLACK H12 C33

eduard

# C Bf 109G-6/AS, WNr. 110087, Hptm. Horst Carganico, CO of I./JG 5, Herzogenaurach, Germany, May 1944

The first unit in which the then twenty-two-year-old Lt. Carganico served after completing flight training was JG 1 at the beginning of the war. This was followed by service with JG 77 with which he saw combat in Norway and then in the Battle of Britain. On January 1, 1941, he returned to Norway where he led I./JG 77. On September 25, 1941, Carganico achieved his 27<sup>th</sup> kill and was awarded the Knight's Cross. In March 1942, Carganico's unit was redesignated 6./JG 5 and he was given command of the entire II. Gruppe in April 1942. On March 26, 1944, he took over I./JG 5 as CO and the unit saw combat against Allied forces within the Defense of the Reich. On April 27 of the same year, Carganico took off for the last time. In an attack on a group of B-17s, his Bf 109G-5 was heavily damaged and during his attempt to belly-land, he struck some high power lines and died in the resulting crash near the French town of Chevry. His final tally consisted of sixty kills over the course of 600 sorties. Bf 109G-6/AS aircraft were assigned to the high altitude interception units therefore they were camouflaged in the overall coat of RLM 76. Hptm. Carganico had Mickey Mouse painted on the fuselage port side, marking carried by his previous airplanes. Starboard side is not photographically documented, it may have carried the Gruppe Commander's double chevron marking.

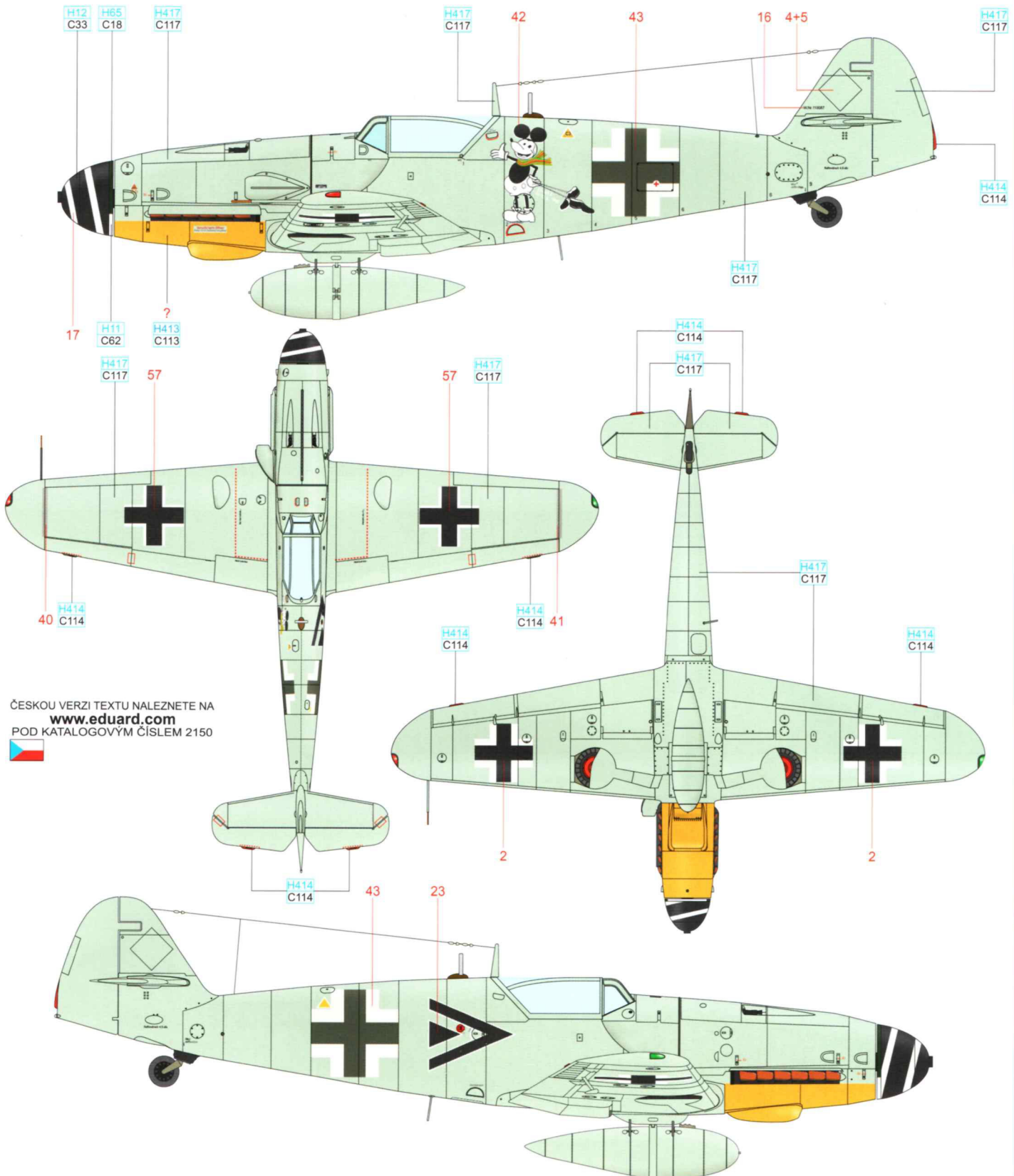

ČESKOU VERZI TEXTU NALEZNETE NA  
[www.eduard.com](http://www.eduard.com)  
 POD KATALOGOVÝM ČÍSLEM 2150



WHITE H11 C62 RLM 76 H417 C117 RLM 70 H65 C18 RLM 04 H413 C113 RLM 23 H414 C114 FLAT BLACK H12 C33



# E Bf 109G-14/AS, Fw. Eberhard Gzik, 2./JG 300, Borkheide, Germany, October 1944

This Bf 109G-14/AS belonging to I./JG 300 was a Series 780 machine produced by the Erla factory in Leipzig. During the fall of the 1944, the I./JG 300 led by Hptm. Gerhard Stamp conducted fighter cover for the Fw 190A-8/R2 Sturmbock heavy fighters. The unit suffered serious losses during tough combats with USAAF fighters in September and October. On October 2, I./JG 300 lost 19 aircraft destroyed and 13 damaged by Mustangs of the 355<sup>th</sup> FG which strafed the Borkheide airfield. Fw. Eberhard Gzik was posted to 9./EJG 2 in November 1944 and flew the Me 262 in Kommando Stamp. He achieved three aerial victories during the war.

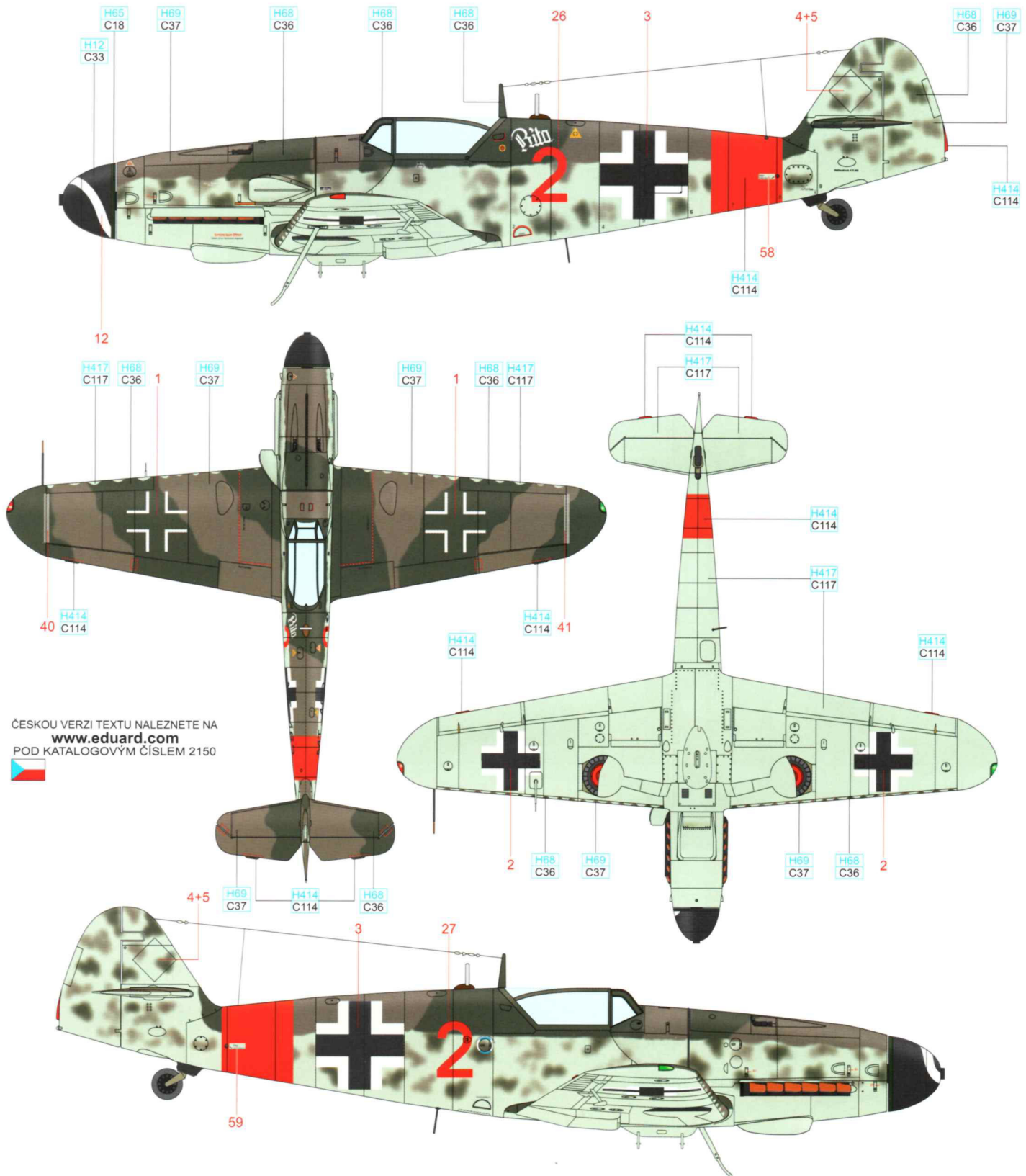

ČESKOU VERZI TEXTU NALEZNETE NA  
[www.eduard.com](http://www.eduard.com)  
 POD KATALOGOVÝM ČÍSLEM 2150



- |        |              |        |            |        |            |        |            |        |              |               |            |
|--------|--------------|--------|------------|--------|------------|--------|------------|--------|--------------|---------------|------------|
| RLM 76 | H417<br>C117 | RLM 75 | H69<br>C37 | RLM 74 | H68<br>C36 | RLM 70 | H65<br>C18 | RLM 23 | H414<br>C114 | FLAT<br>BLACK | H12<br>C33 |
|--------|--------------|--------|------------|--------|------------|--------|------------|--------|--------------|---------------|------------|

# F Bf 109G-14/AS, WNr. 784986, Ofw. Paul Schwerdtfeger, 11./JG 6 Bissel, Germany, January, 1945

Since 1944 Ofw. Paul Schwerdtfeger logged many sorties as a reconnaissance pilot. In the summer 1944 he volunteered to the fighter air corps and on January 1, 1945 took off as a member of 11./JG 6 staff flight for his first combat sortie in the fighter role. JG 6 target was supposed to be Volkel airport however the unit commander led his unit much further to the south. Ofw. Schwerdtfeger's aircraft was hit by an anti-aircraft artillery fire nearby Helmond. The pilot tried to reach German lines however he crash-landed and was killed nearby Groesbeek. Ofw. Schwerdtfeger aircraft flew camouflaged in typical camouflage from the Messerschmitt factory in Regensburg, in RLM 74/75/76 colors. Vertical tail surface and rudder were manufactured by the sub-contractor and painted in the same colors with sharp-edged blotches of RLM 74, overpainted slightly by RLM 76 blotches, 900 mm red-white-red stripe was spray-painted on the rear of the fuselage. This was Jagdegeschwader 6 recognition marking for its Reich Defense role.

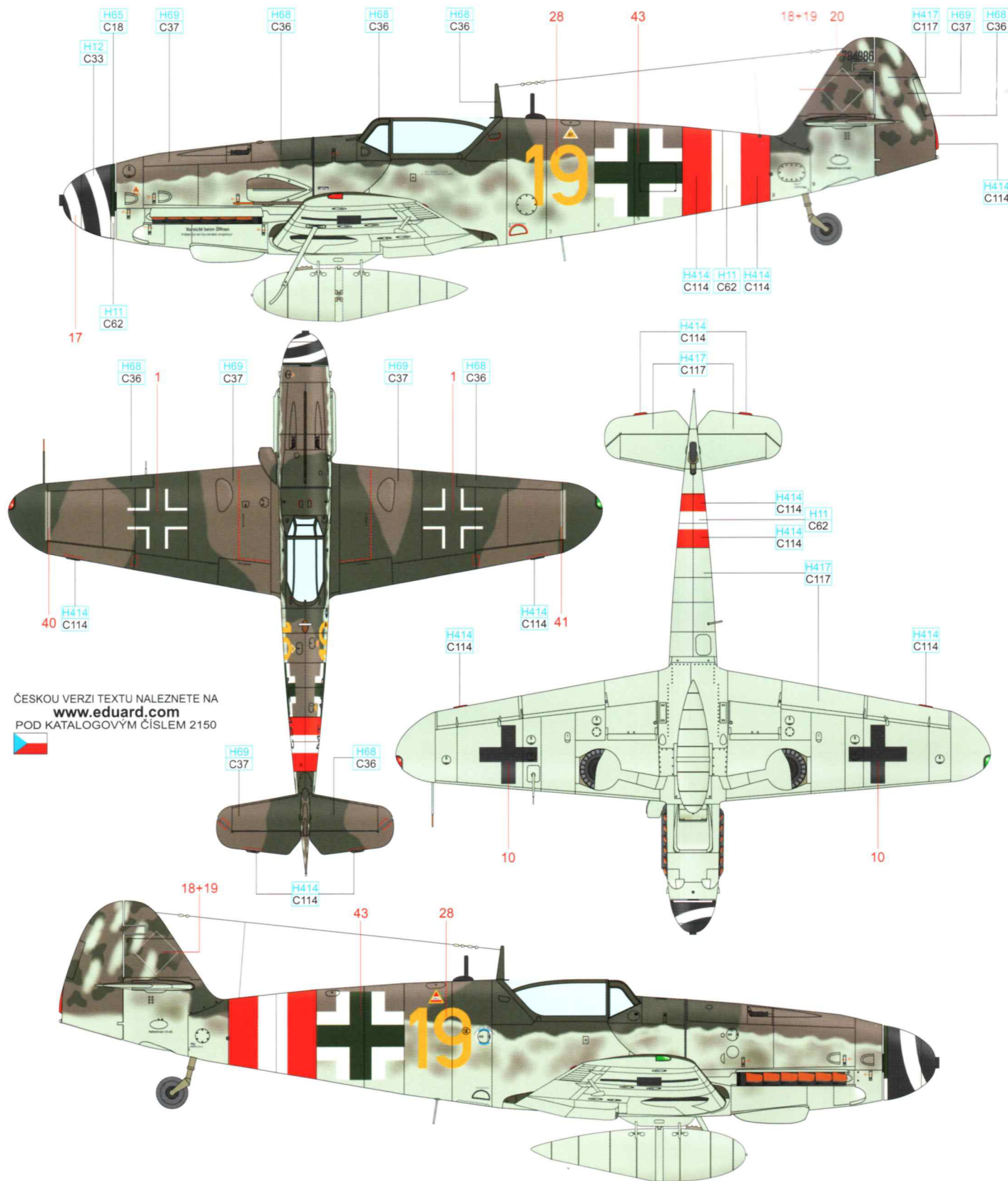

ČESKOU VERZI TEXTU NALEZNETE NA  
[www.eduard.com](http://www.eduard.com)  
 POD KATALOGOVÝM ČÍSLEM 2150



WHITE H11 C62 RLM 76 H417 C117 RLM 75 H69 C37 RLM 74 H68 C36 RLM 70 H65 C18 RLM 23 H414 C114 FLAT BLACK H12 C33

eduard

**G** Bf 109G-14/AS, WNr. 785185, Lt. Heinz Schüler, 16./JG 5, Stavanger-Forus, Norway, March 1945

In November 1944 in Stavanger 16. Staffel Jagdgeschwader 5 was established in order to boost the IV. Gruppe inventory to four Staffels. The IV./JG 5 equipment was unified to Bf 109G-14 even though couple of Fw 190 continued flying with the unit till the end of 1944. Bf 109G-14/AS marked blue 17 was flown by Lt. Heinz Schüler who painted Berlin's coat of arms under the windshield. It is apparent in the photographs that at that time the aircraft did not carry the Defense of the Reich markings, however when Lt. Schüler landed it on March 27, 1945, at Stavanger-Sola airport it sported black and yellow bands (JG 5 aircraft marking) behind the fuselage national insignia. The upper sides were camouflaged in RLM 74/75 colors in standard camouflage pattern from the Messerschmitt factory in Regensburg.

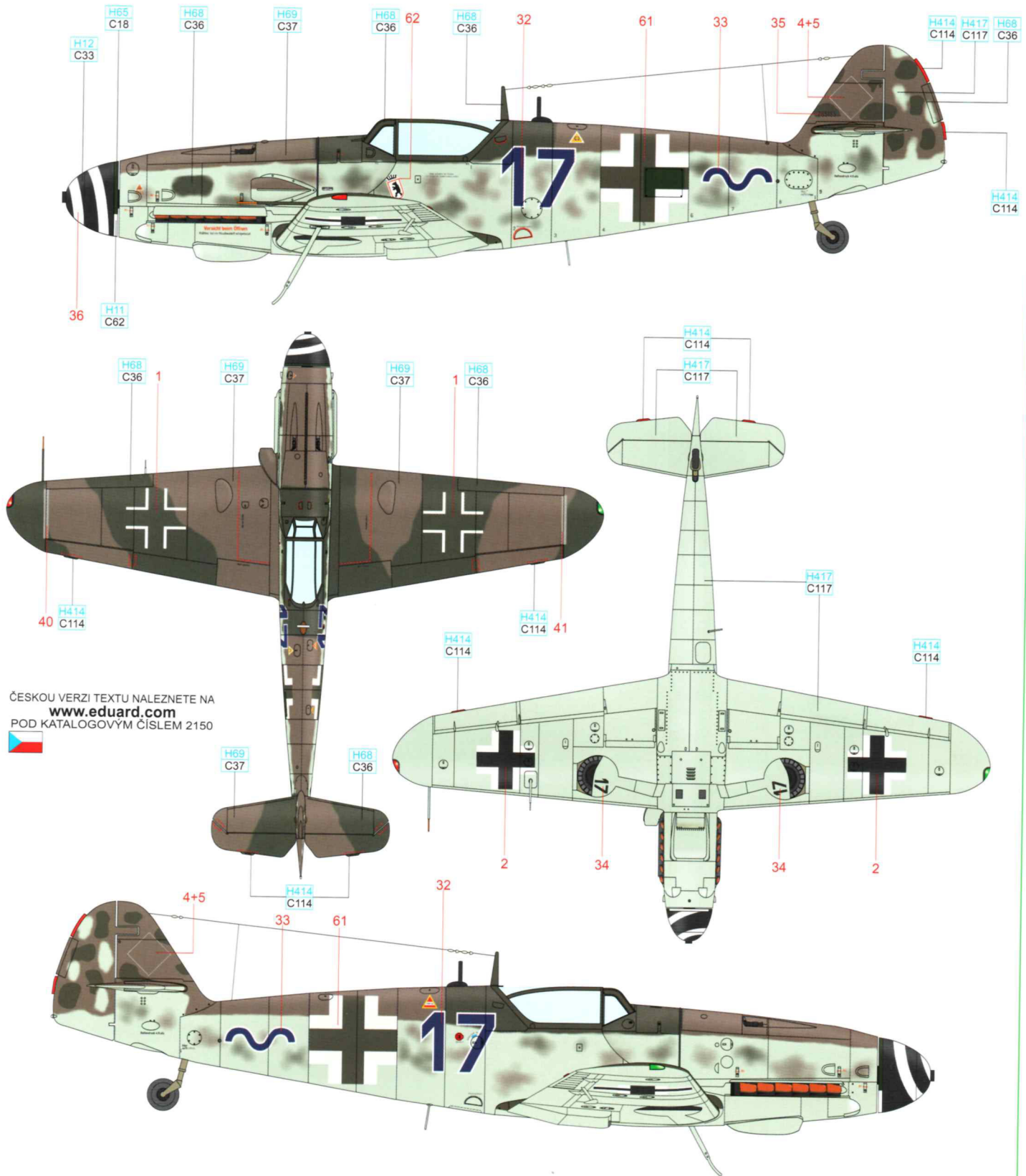

ČESKOU VERZI TEXTU NALEZNETE NA  
[www.eduard.com](http://www.eduard.com)  
 POD KATALOGOVÝM ČÍSLEM 2150



- |       |            |        |              |        |            |        |            |        |            |        |              |               |            |
|-------|------------|--------|--------------|--------|------------|--------|------------|--------|------------|--------|--------------|---------------|------------|
| WHITE | H11<br>C62 | RLM 76 | H417<br>C117 | RLM 75 | H69<br>C37 | RLM 74 | H68<br>C36 | RLM 70 | H65<br>C18 | RLM 23 | H414<br>C114 | FLAT<br>BLACK | H12<br>C33 |
|-------|------------|--------|--------------|--------|------------|--------|------------|--------|------------|--------|--------------|---------------|------------|



**Bf 109G-14/AS (Mtt Reg), WNr. 784993, Uffz. Herbert Maxis, 13./JG 53, Stuttgart-Echterdingen, Germany, January, 1945**

In the ranks of IV./JG 53, Uffz. Maxis was to participate in the raid on Metz-Frescaty airport captured by the US troops. During the flight to the target, together with the other pilots, he attacked the 455<sup>th</sup> AAA Battalion post located nearby Ittersdorf. He was shot down however, force-landed and after getting out of the cockpit he was shot to death by the member of the Battery A of the field artillery 739<sup>th</sup> Batalion. Maxis' burial place remains unknown. Uffz. Maxis' Bf 109G-14/AS flew camouflaged in RLM 74/75/76, in typical camouflage pattern from the Messerschmitt factory in Regensburg. Vertical tail surface and rudder were manufactured by the sub-contractor and painted in the same colors with sharp-edged blotches of RLM 74. 900 mm wide black stripe around the rear fuselage indicated JG 53 aircraft deployed in the Reich Defense role.

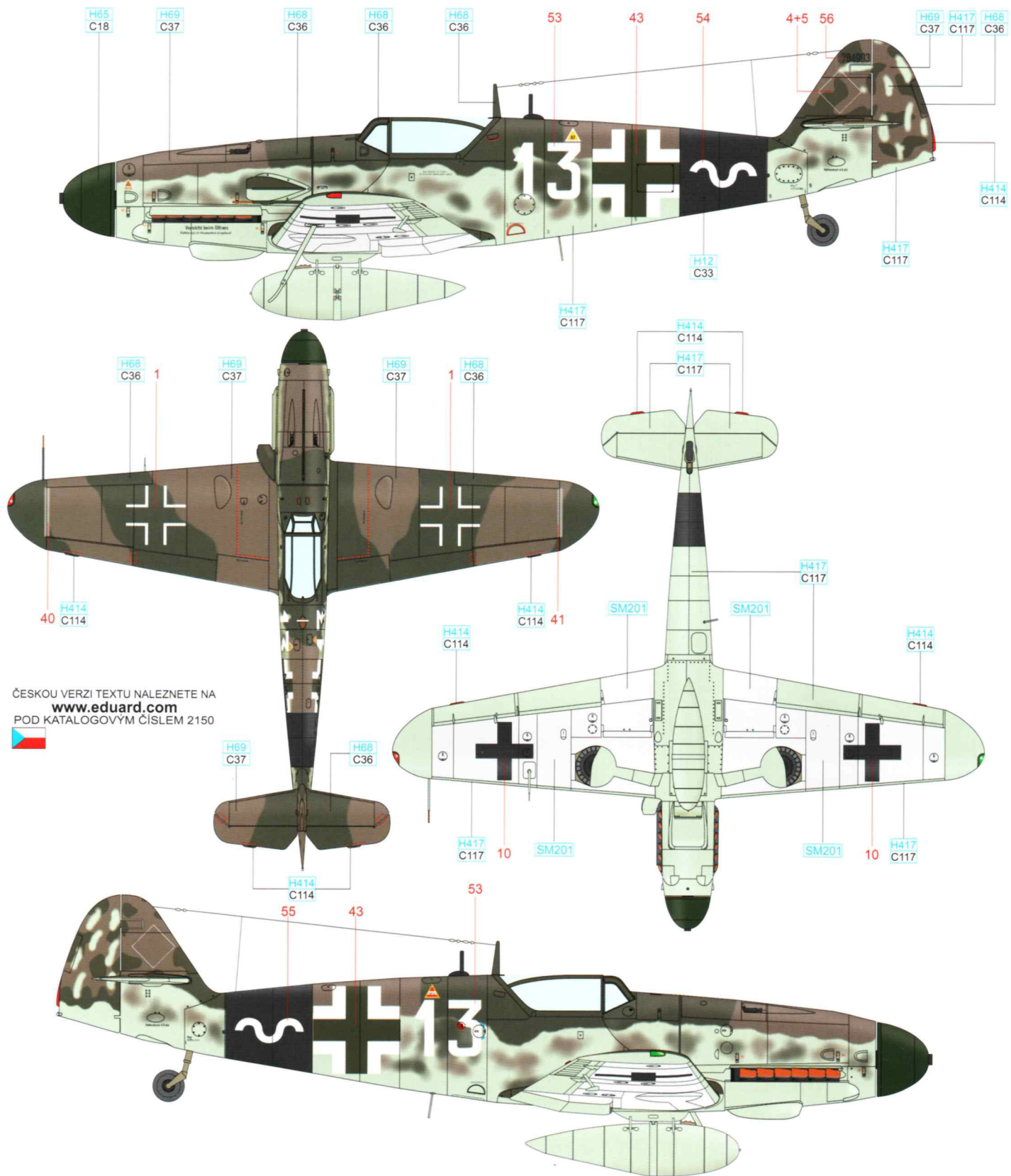

ČESKOU VERZI TEXTU NALEZNETE NA  
[www.eduard.com](http://www.eduard.com)  
 POD KATALOGOVÝM ČÍSLEM 2150



SUPER FINE SILVER 2 SM201

RLM 76 H417 C117 RLM 75 H69 C37 RLM 74 H68 C36 RLM 70 H65 C18 RLM 23 H414 C114 FLAT BLACK H12 C33



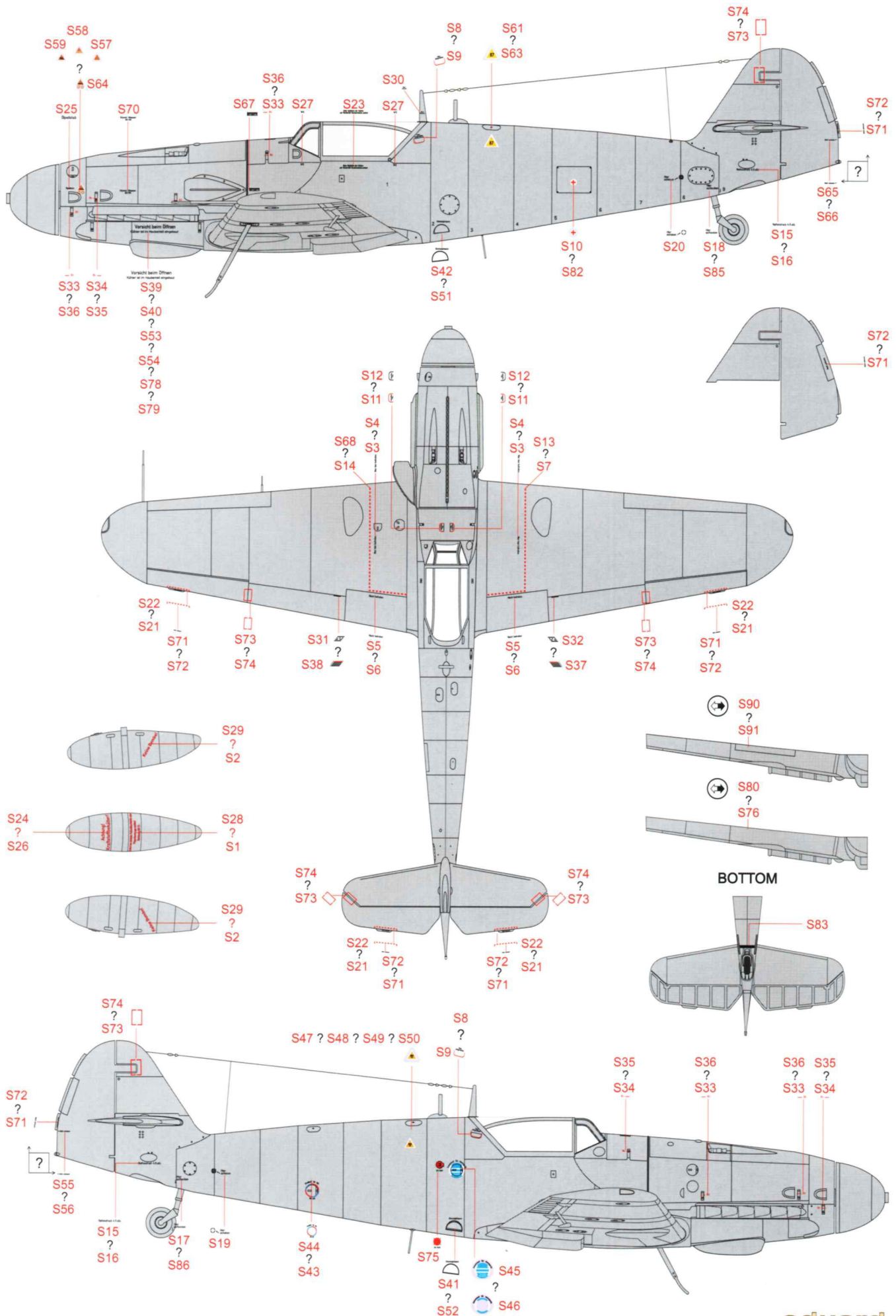

MARKING D ONLY

