

G.I.M.H.[®]

1/72
SCALE
S7208



DIGITAL CAMOUFLAGE WITH

TIGER ON TAIL

MiG-29AS 9-12 LATE TYPE SLOVAK AIRFORCE

2014/2016 SPECIAL PAINTING

MiG-29AS 9-12 后期型 斯洛伐克空军数码迷彩特别纪念涂装限量版

注意事項 CAUTION 組み立てのご注意

- (1) 勿于近火处使用胶水或油漆, 并打开窗户保持空气流通。
- (2) 涂料的号码请参考本栏以下的说明。本品本身不包括胶水和涂料。
- (3) 自板件中取出部件时, 应用模型专用剪, 并用介刀或小锉除去多余胶料。
- (4) 各图形的含义可参考本栏以下说明。

- (1) When you use glue or paint, do not use near a open flame, and use in a well-ventilated room.
- (2) See below for the color list. Glue and paint are not included in the kit.
- (3) When you take parts off the runner frame, use the modeling scissors and trim excess plastic with a cutter or a file.
- (4) See below for the meaning of symbols.

- (1) 接着剂や塗料は火の近くで使わないで下さい。使用の際は換気をよくして下さい。
- (2) 塗料指定のは下記のとおりです。接着剂や塗料は入っていませんので別に求めて下さい。
- (3) 部品のランナーから切り離す時は模型用ハサミ等を使い、余分な部分はカッターやヤスリ等で仕上げして下さい。
- (4) 組立図のサインマークは下の説明を御覧下さい。

图形含义 CAUTION マーク

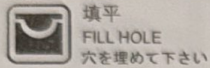

填平
FILL HOLE
穴を埋めて下さい

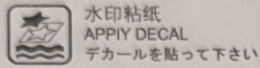

水印粘紙
APPLY DECAL
デカールを貼って下さい

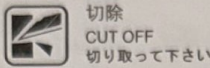

切除
CUT OFF
切り取って下さい

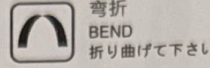

弯折
BEND
折り曲げて下さい

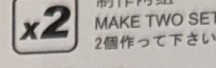

制作两组
MAKE TWO SET
2個作って下さい

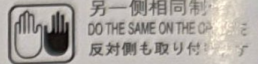

另一側相同制作
DO THE SAME ON THE OTHER SIDE
反対側も取り付けて下さい

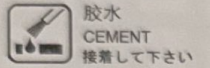

胶水
CEMENT
接着して下さい

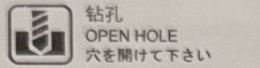

钻孔
OPEN HOLE
穴を開けて下さい

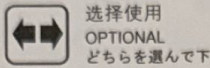

选择使用
OPTIONAL
どちらを選んで下さい

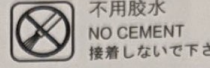

不用胶水
NO CEMENT
接着しないで下さい

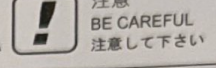

注意
BE CAREFUL
注意して下さい

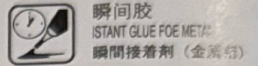

瞬间胶
INSTANT GLUE FOR METAL
瞬間接着剂 (金属用)

所使用工具 RECOMMENDED TOOLS 専用工具

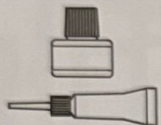

塑胶件用模型胶水
Cement
プラスチック用接着剂

模型用瞬间胶水
Instant Cement
瞬間接着剂

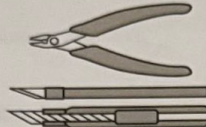

模型用剪钳
Side cutters
模型用ニッパー

模型用刻刀
Modeling knife
模型用ナイフ

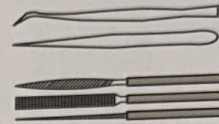

模型用镊子
Tweezers
ピンセット

模型用锉刀
Diamond file
模型用ヤスリ

水贴纸使用说明 DECAL APPLICATION スライドマークの貼り方

- (1) 用模型剪刀或刻刀切下所需的图案部分。
- (2) 将水贴纸浸泡在温水中10秒左右取出放置于戏水的干布上。
- (3) 手拿着水贴纸基的一角, 用模型镊子小心夹住浮起的水贴图案移至模型表面准确位置。
- (4) 用手指适当沾水均匀涂于水贴图案表面, 使其延展移动至精确位置。
- (5) 用柔软吸水的干布将水贴图案中的气泡向一边挤出, 使水贴在模型表面保持平整。

- (1) Cut off decal from sheet.
- (2) Dip the decal in tepid water for about 10 sec. and place on a clean cloth.
- (3) Hold the backing sheet edge and slide decal onto the model.
- (4) Move decal into position by wetting decal with finger.
- (5) Press decal down gently with a soft cloth until excess water and air bubbles are gone.

- (1) 貼りたいマークをハサミで切り抜きます。
- (2) マークをぬるま湯に10秒ほど浸してからタオル等の布の上に置きます。
- (3) 台紙のはしを手で持ち、貼るところにマークをスライドさせてモデルに移して下さい。
- (4) 指に少し水を付けてマークを濡らしてながら、正しい位置にずらしします。
- (5) 柔らかい布でマークの内側の気泡を押し出しながら、押しつけるようにして水分をとります。

蚀刻片使用说明 PHOTO-ETCHED PARTS エッチングパーツ

- (1) 使用蚀刻片专用剪刀或模型专用刻刀将蚀刻片零件切割下待用。
 - (2) 切割下的零件上有蚀刻片的残留连接点部分, 使用模型专用锉刀细心打磨干净。
 - (3) 蚀刻片部分在涂装之前必须使用专用的模型金属底漆打底。
- 注意事项: 蚀刻片很薄外延较为尖锐, 有刮伤手的可能, 在使用之时请务必小心。

- (1) Cut off photo-etched parts using a modeling knife.
 - (2) Carefully remove any excess using a file.
 - (3) Apply metal primer prior to painting.
- Attention, please: Extra care should be taken to avoid personal injury when handling photo-etched parts.

- (1) 切り離す時はカッターナイフを使用してパーツを切り離します。
 - (2) 切り出した時、部品に出張った部品が残っている場合は、ヤスリなどで丁寧に削り落とします。
 - (3) 塗装が必要なパーツは下地にメタルプライマーを吹きつけてから塗装します。
- ご注意: エッチングパーツは大変薄く、手などを切り恐れがあります。取扱いは十分注意して下さい。

涂装色表 PAINT REQUIRED カラー番号リスト

■ [C]000 GSI CREOS Mr.COLOR ■ [00-000] ACRYLICOS VALLEJO ■ FS00000 联邦色号

[C]1	白色	White	[C]41	红棕	Red brown
[C]2	黑色	Black	[C]45	帆布色	Canvas
[C]3	红色	Red	[C]47	透明红	Clear red
[C]6	绿色	Green	[C]58	橙黄	Orange yellow
[C]8	银色	Silver	[C]61	烧铁色	Burning iron
[C]25	暗海灰	Dark gray	[C]62	消光白	Nero White
[C]28	黑铁	Black iron	[C]73	机灰色	Gray
[C]33	消光黑	Nero nemesis	[C]117	RLM76淡蓝	RLM76 Light Blue
[C]118	RLM78淡蓝	RLM78 Light Blue	[SM]213	不锈钢色	Stainless steel color
[C]136	俄国绿2	Russian Green 2	[SM]214	暗铁色	Dark Iron
[C]138	透明绿	Transparent green			
[C]306	灰FS36270	Grey FS36270			
[C]308	灰FS36375	Grey FS36375			
[C]311	灰FS36622	Grey FS36622			
[C]319	淡绿	Light green			
[SM]03	超级熟铁色	Super Wrought Iron			

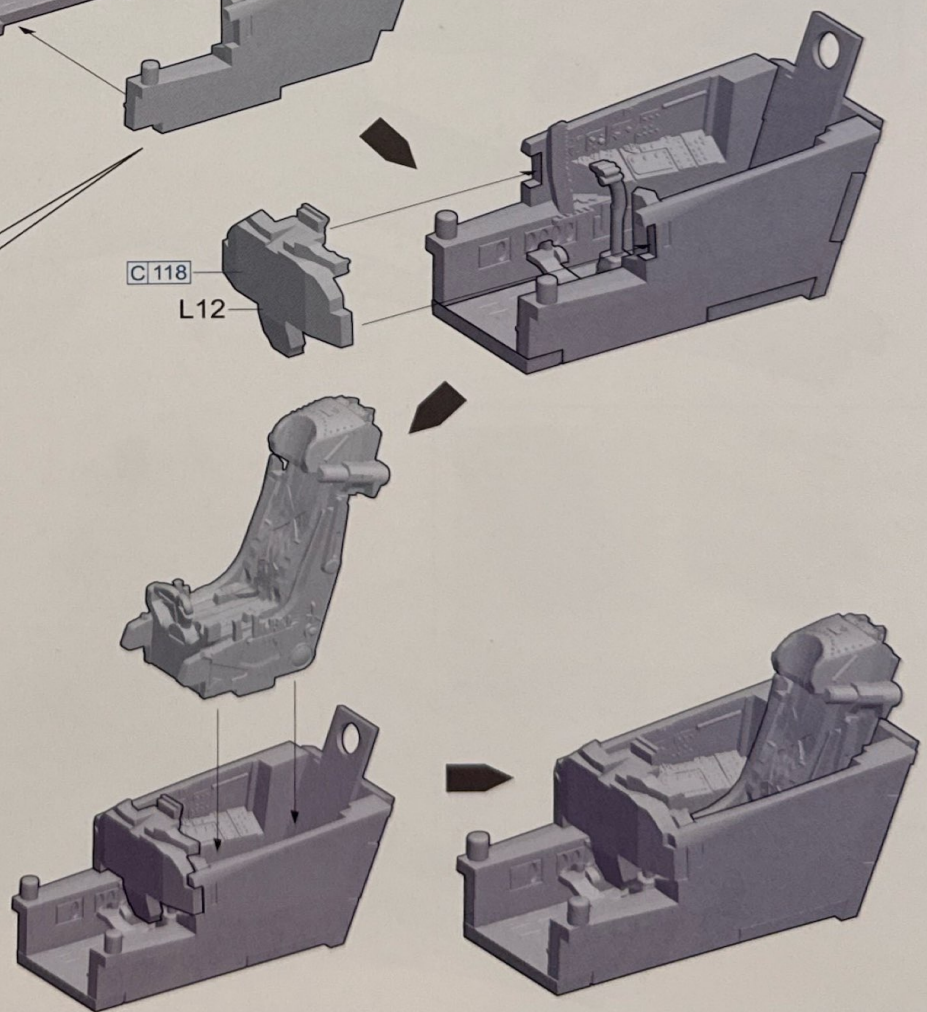
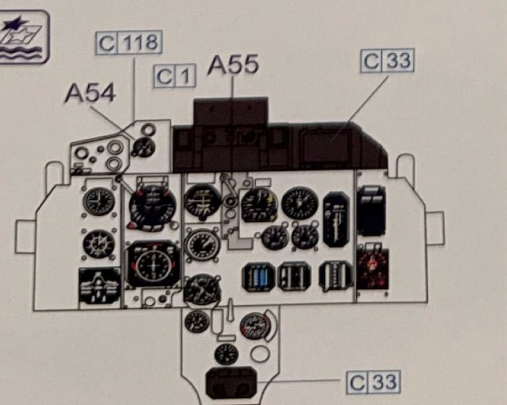
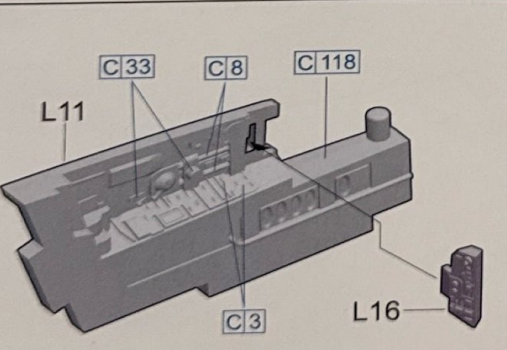
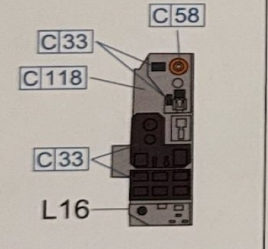
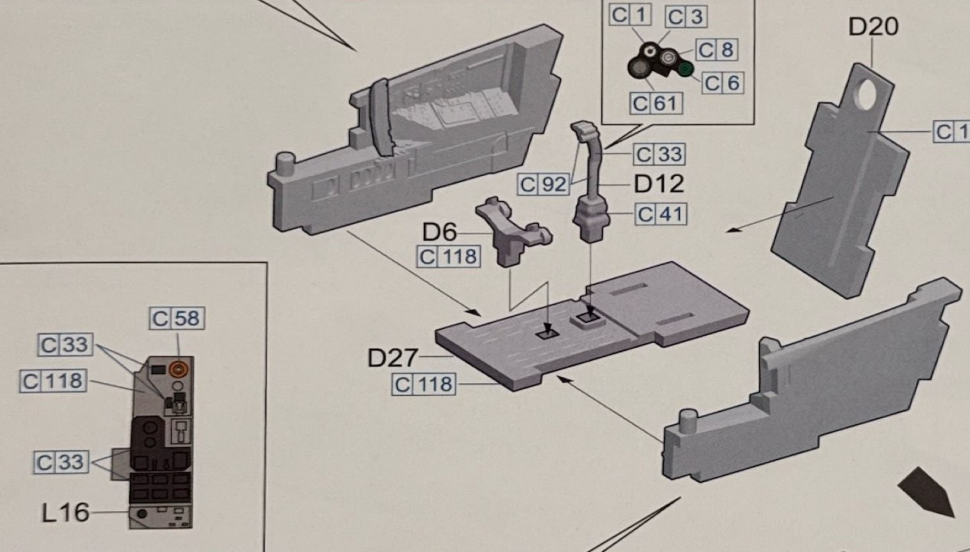
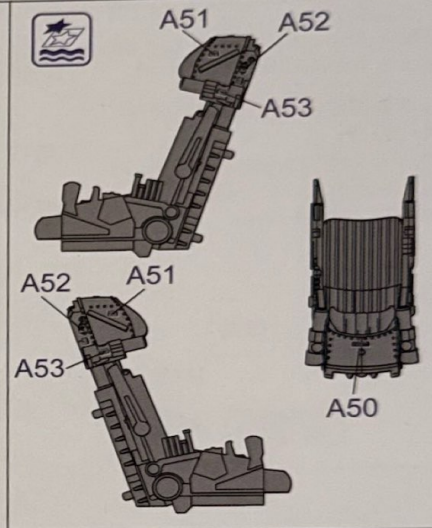
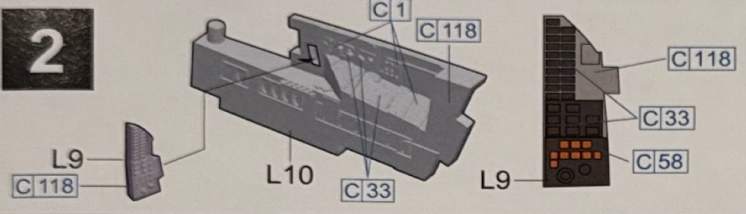
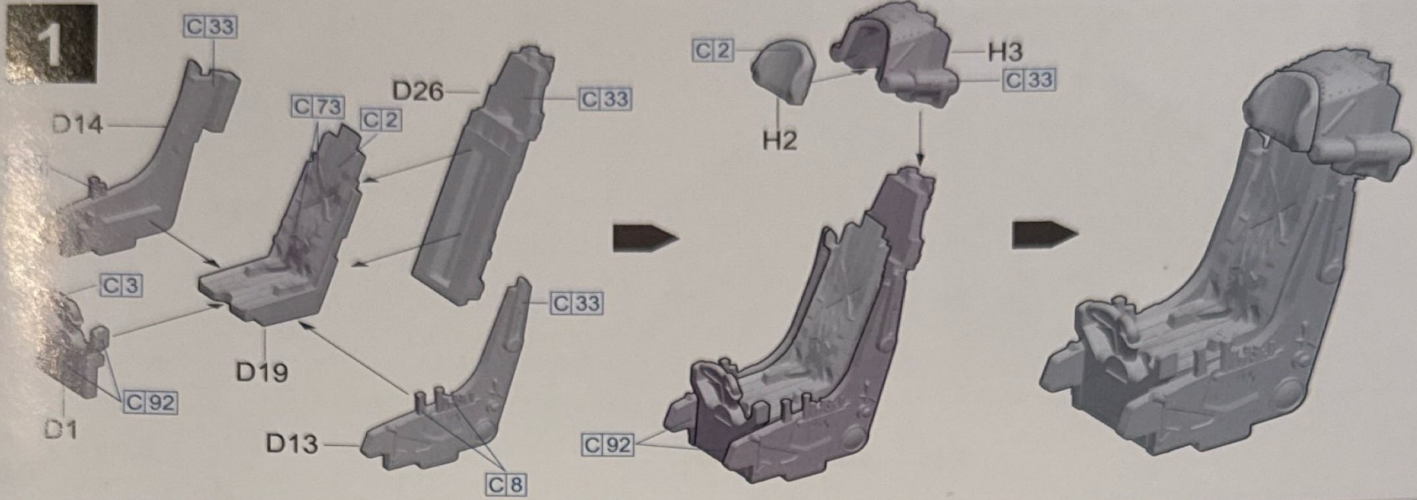

3

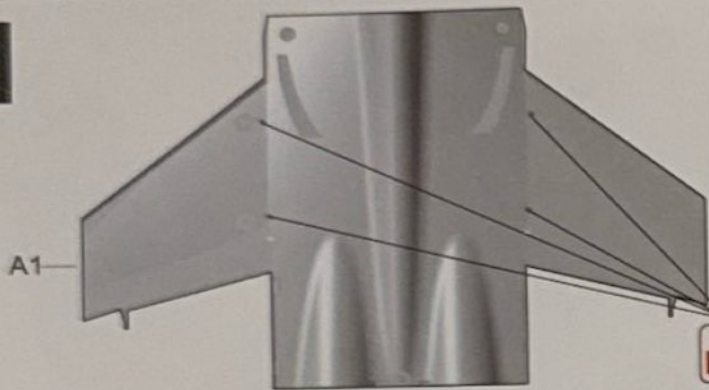

Diameter: 1.1mm
圆孔直径: 1.1mm

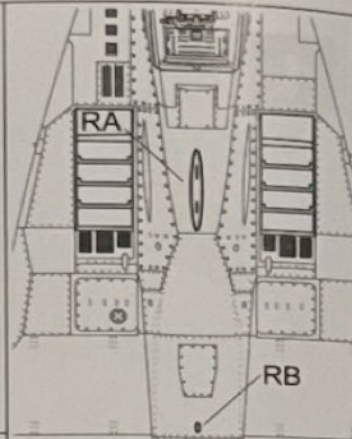

发动机关机及飞行状态时，辅助进气门关闭
When engine off or in the air, upper intake doors closed

在地面发动机运行时，辅助进气门打开
When MiG-29 on the ground and engines running, upper intake doors open

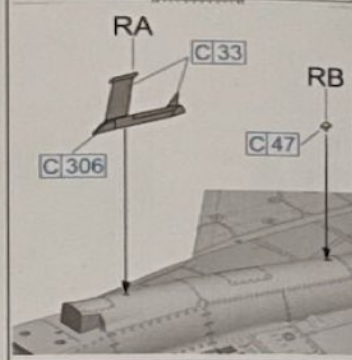
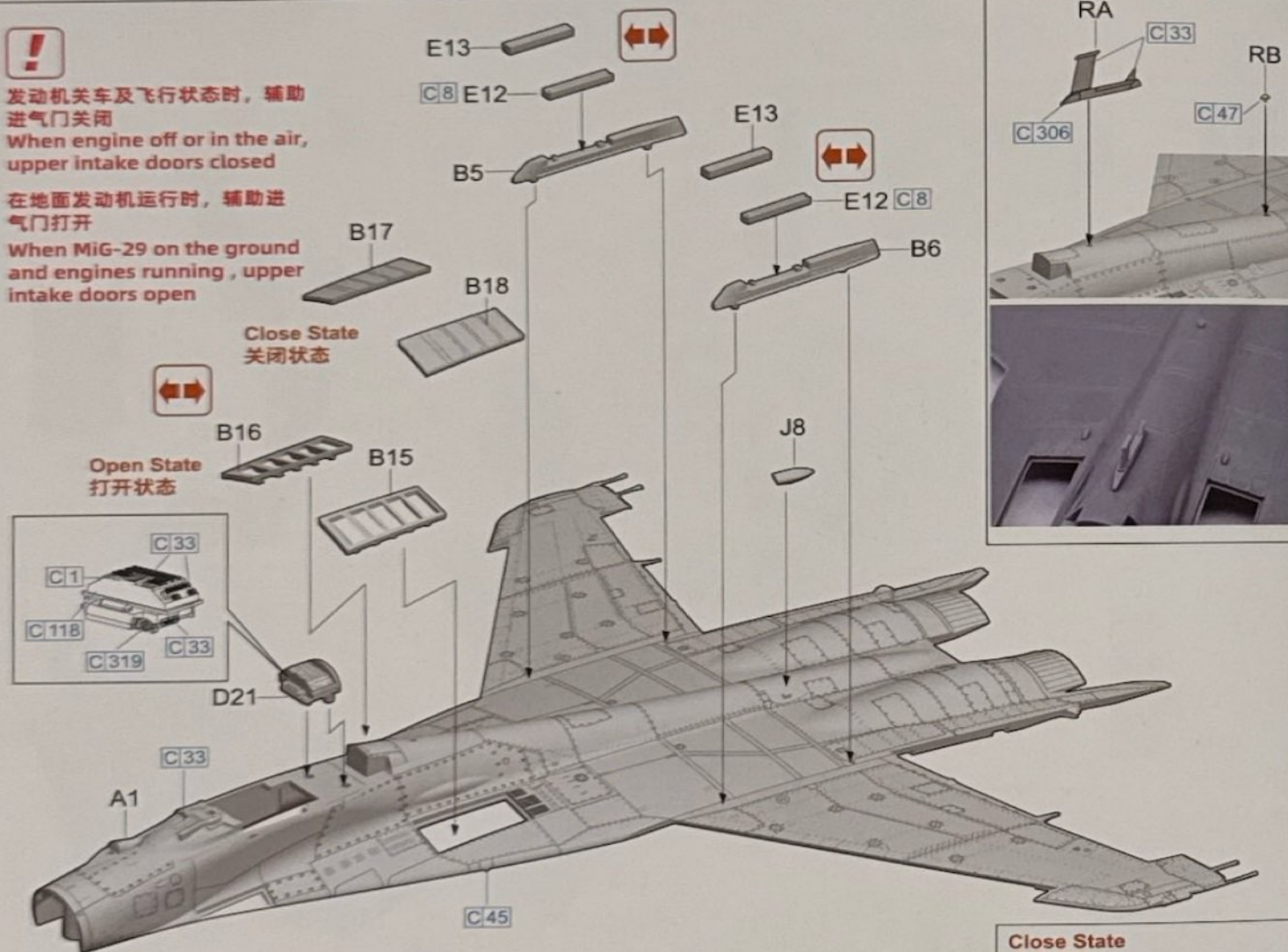

Close State
关闭状态

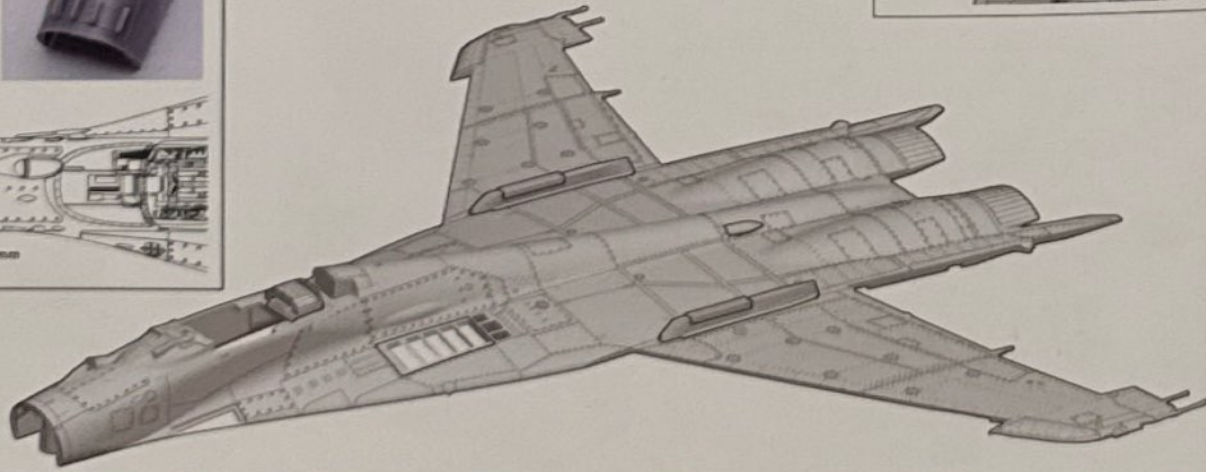
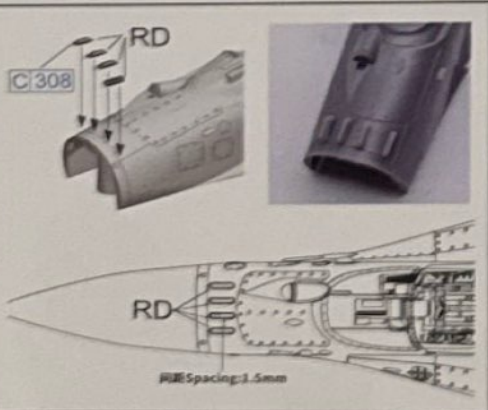

4

Diameter: 0.8mm
圆孔直径: 0.8mm

! 用于PTB-1150副油箱/BD3-USK挂架
For PTB-1150 fuel tank/BD3-USK pylon

Diameter: 0.8mm
圆孔直径: 0.8mm

Diameter: 1.1mm
圆孔直径: 1.1mm

! 用于APU-470 挂架
For APU-470 Pylon

B4

B13

C308

B14

C308

RD

RC

RC

RD

C308

B4

J4

C308

D16

C308

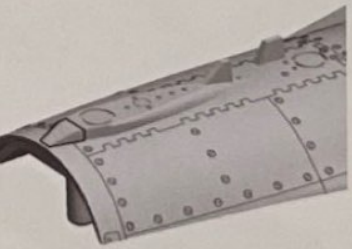

5

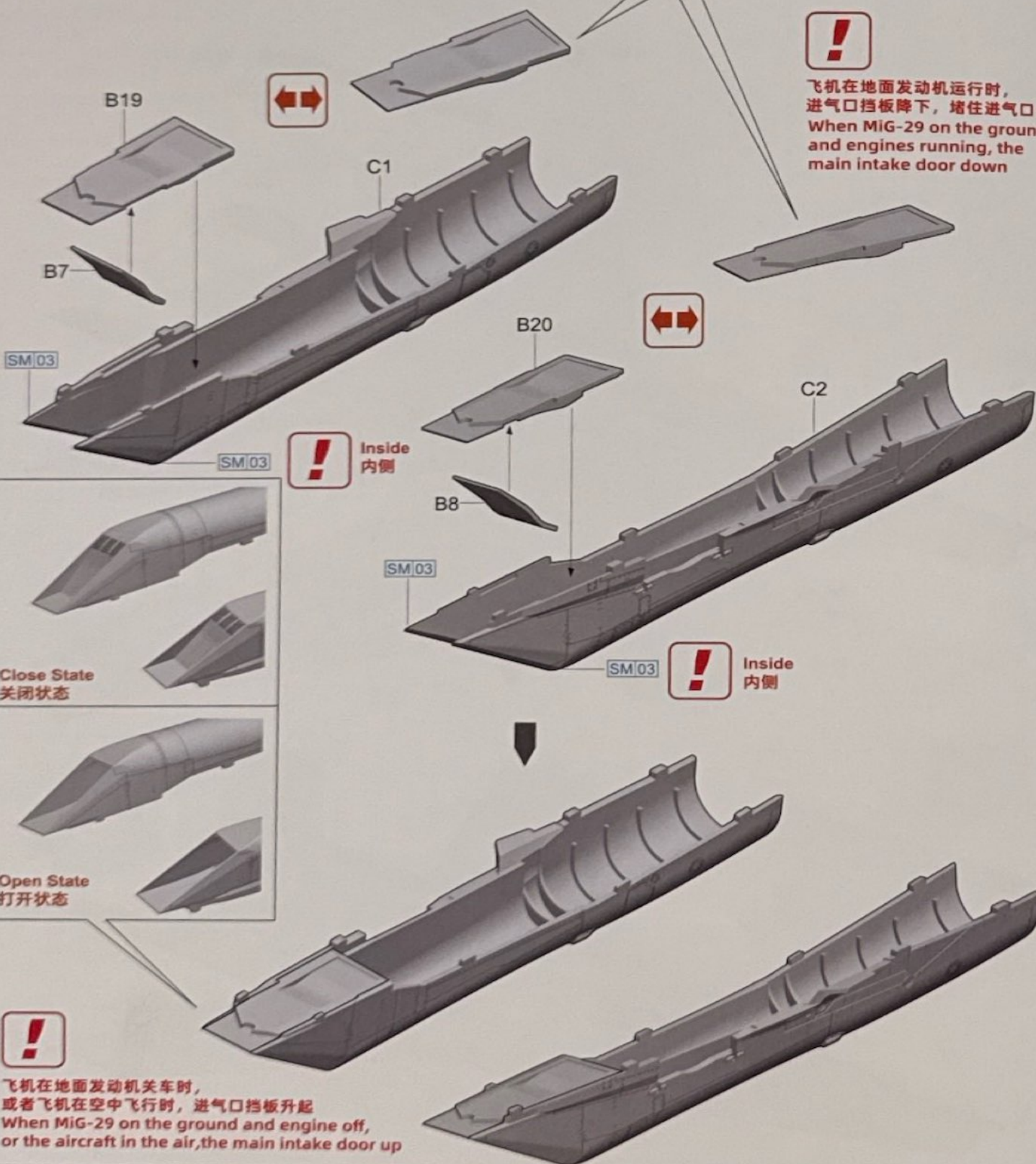
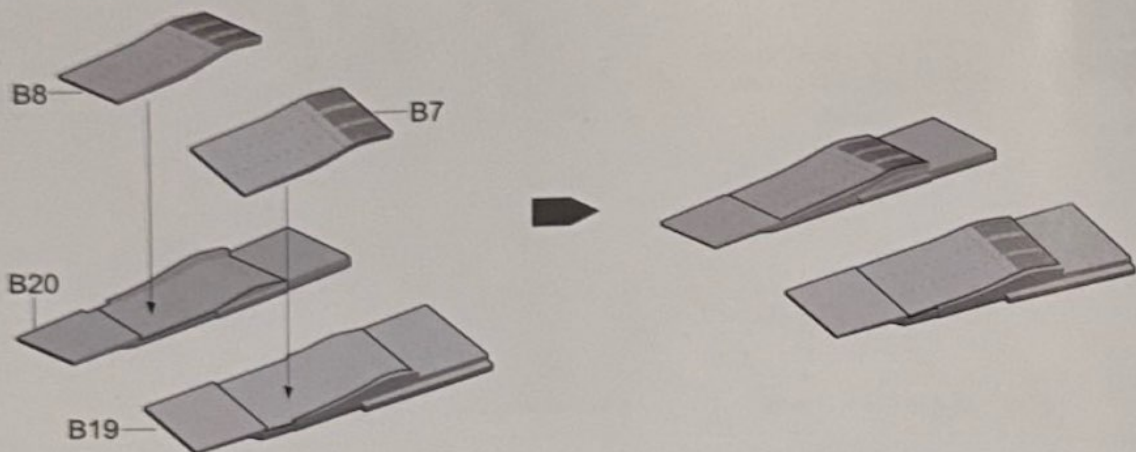

!
 飞机在地面发动机运行时，
 进气口挡板降下，堵住进气口
 When MiG-29 on the ground
 and engines running, the
 main intake door down

! Inside
 内侧

! Inside
 内侧

Close State
 关闭状态

Open State
 打开状态

!
 飞机在地面发动机关车时，
 或者飞机在空中飞行时，进气口挡板升起
 When MiG-29 on the ground and engine off,
 or the aircraft in the air, the main intake door up

6

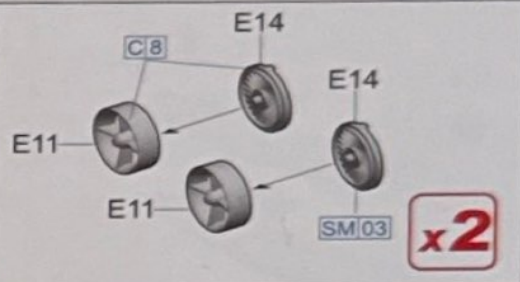
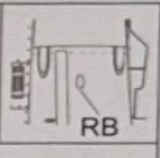
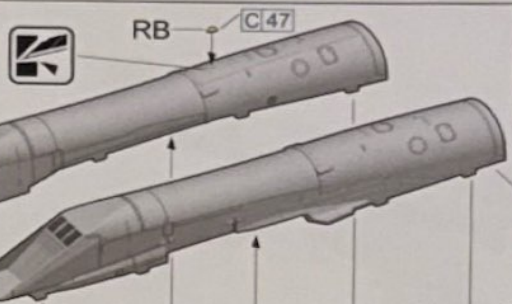

C45 Inside 内側

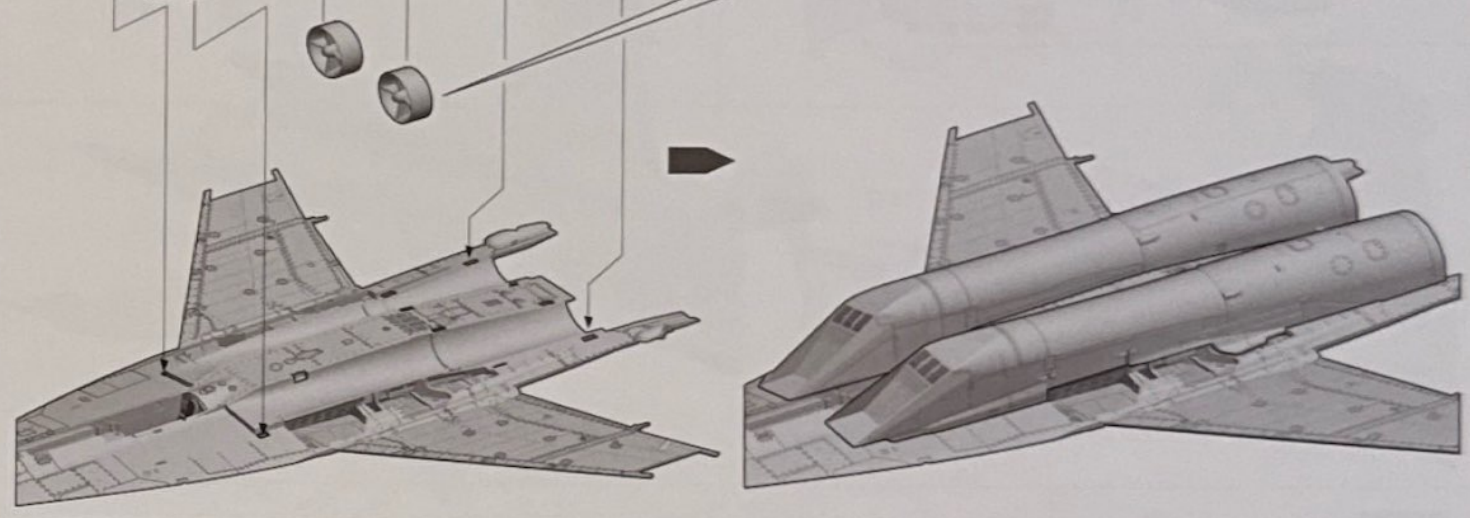

7

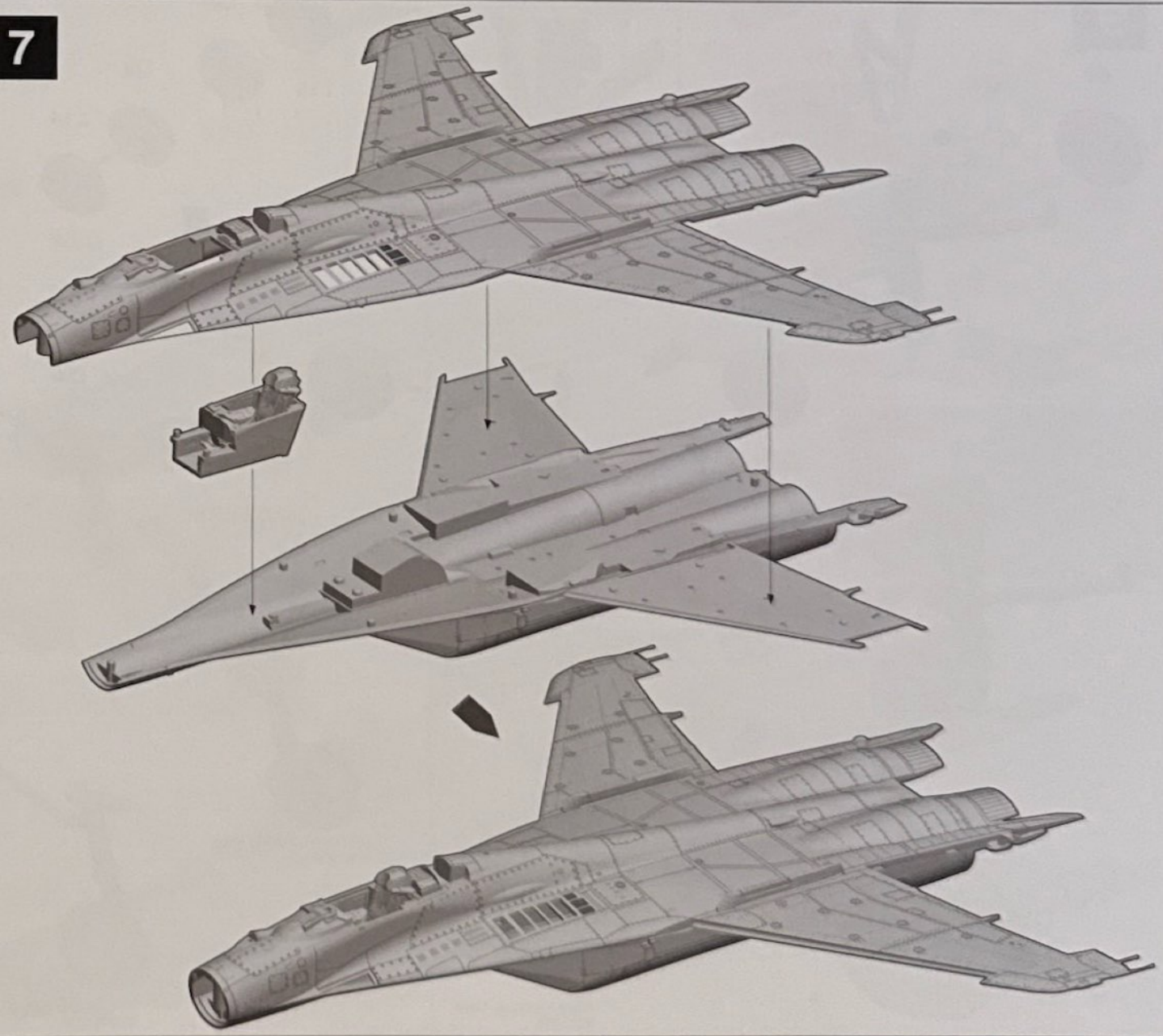

8

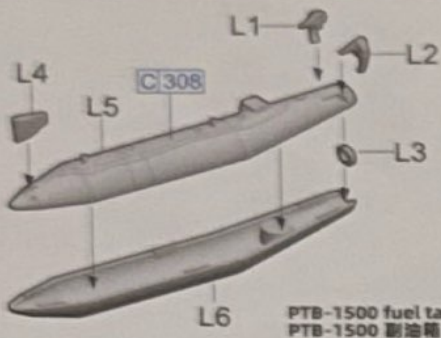

PTB-1500 fuel tank
PTB-1500 副油箱

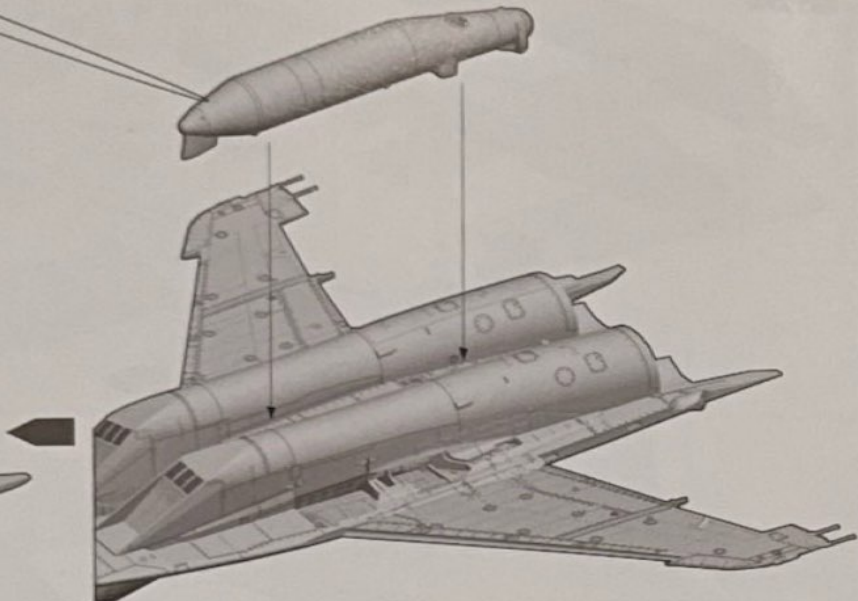
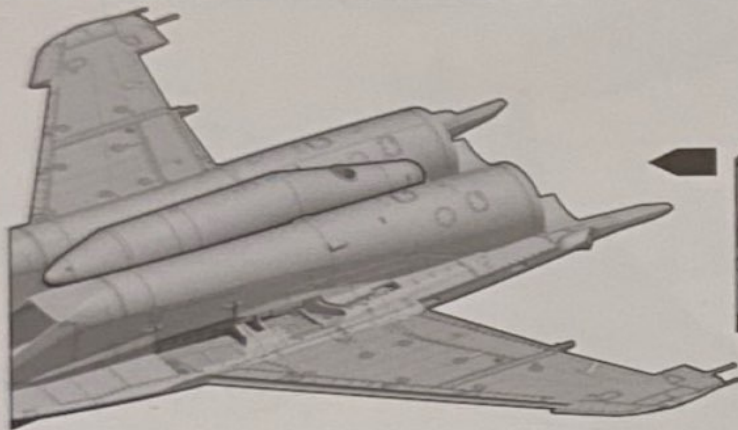

9

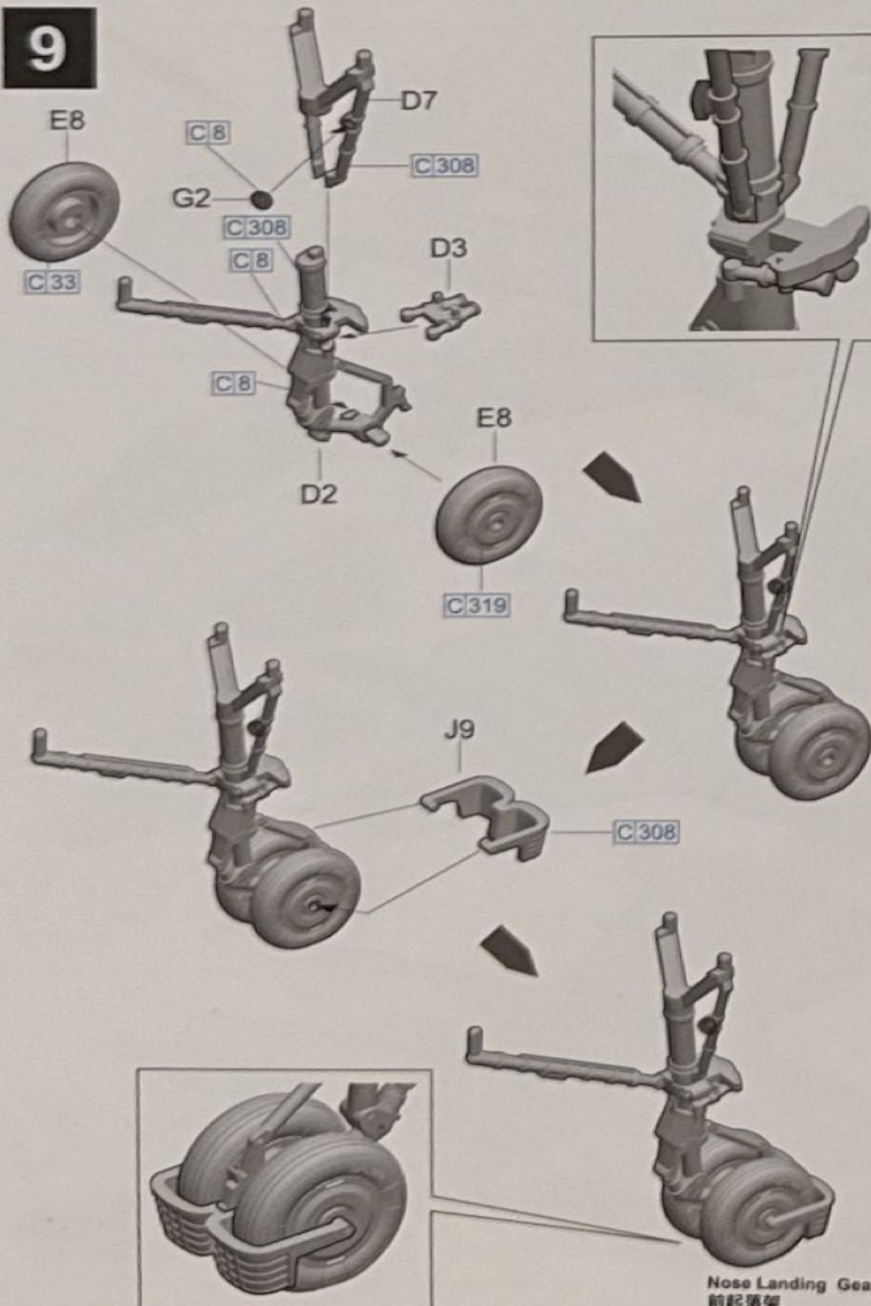

Nose Landing Gear
前起落架

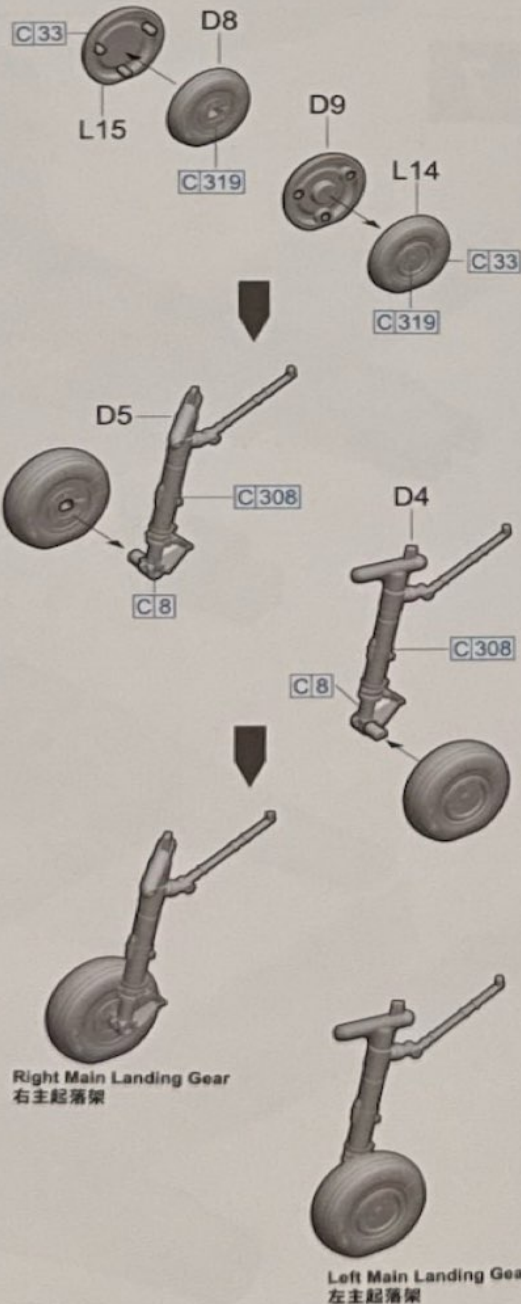

Right Main Landing Gear
右主起落架

Left Main Landing Gear
左主起落架

10

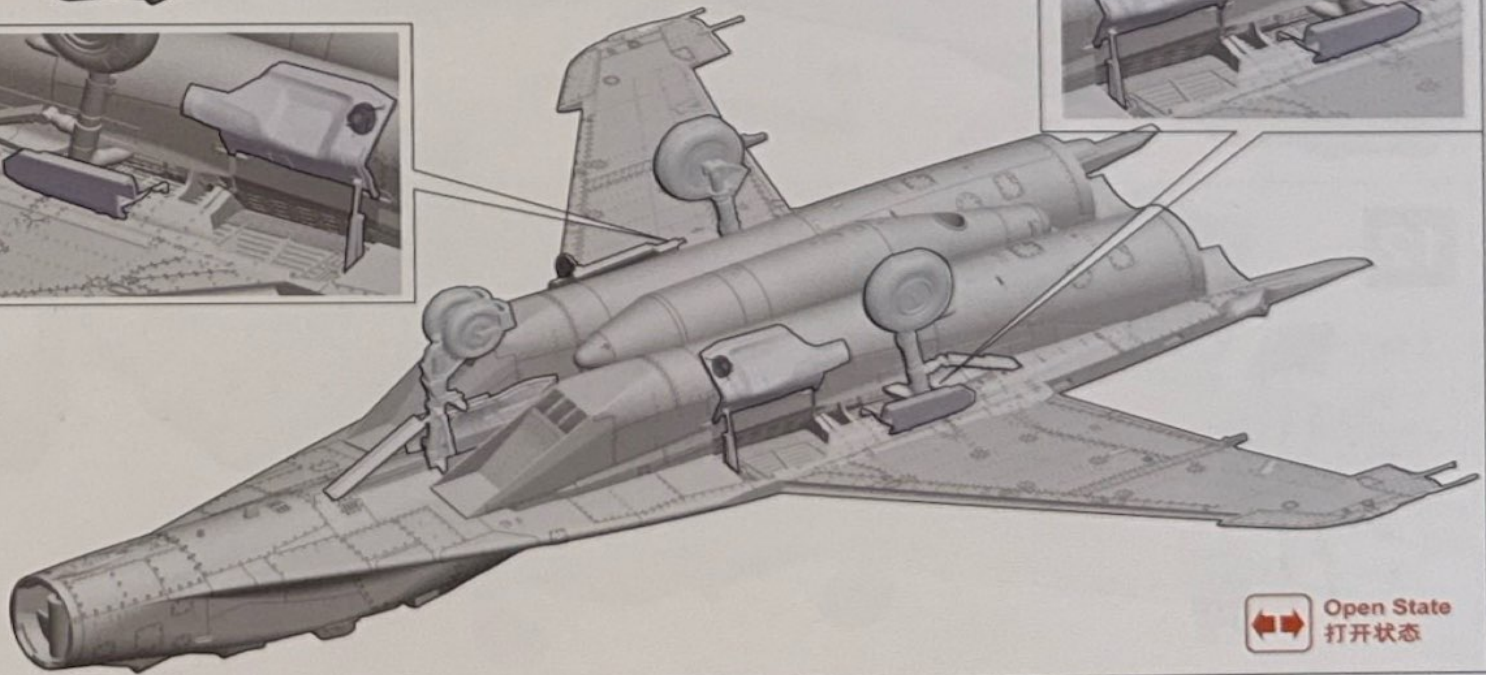
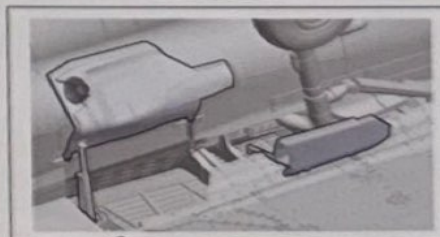
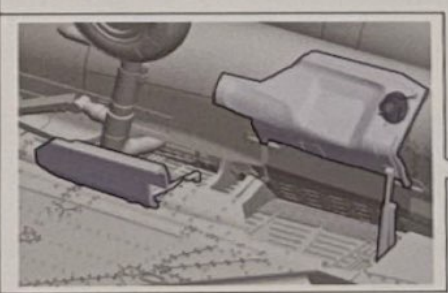
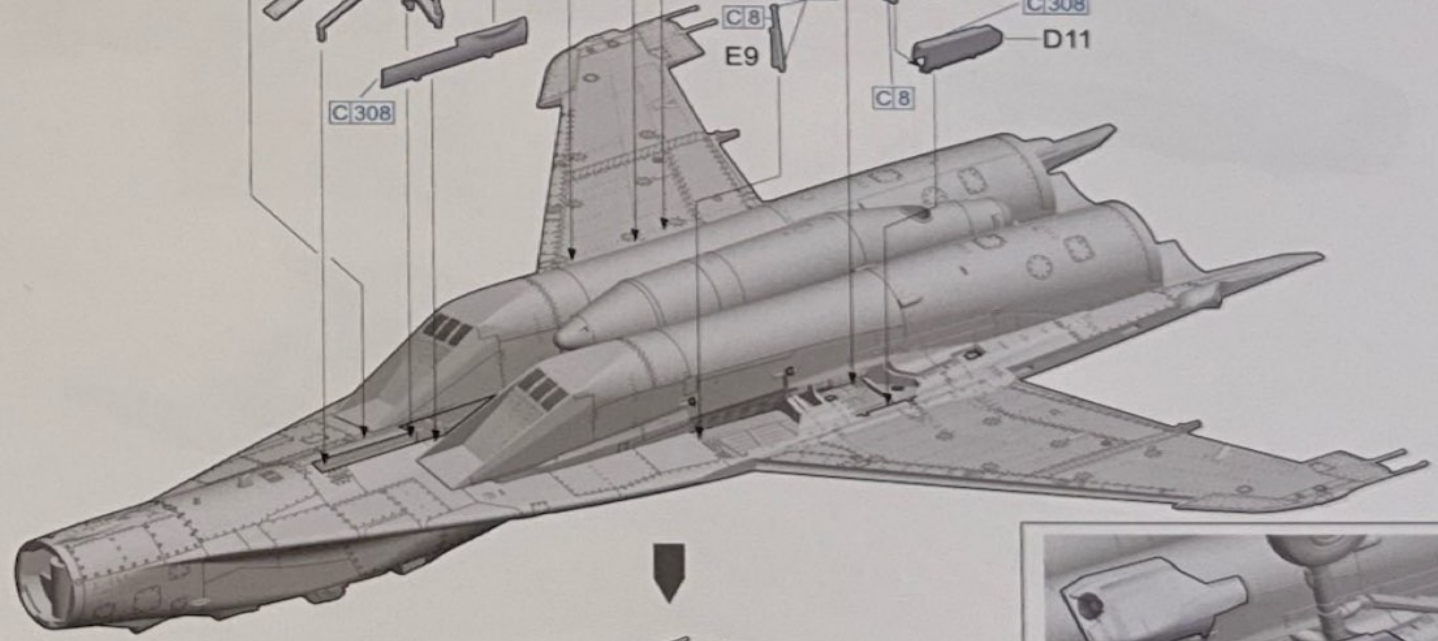
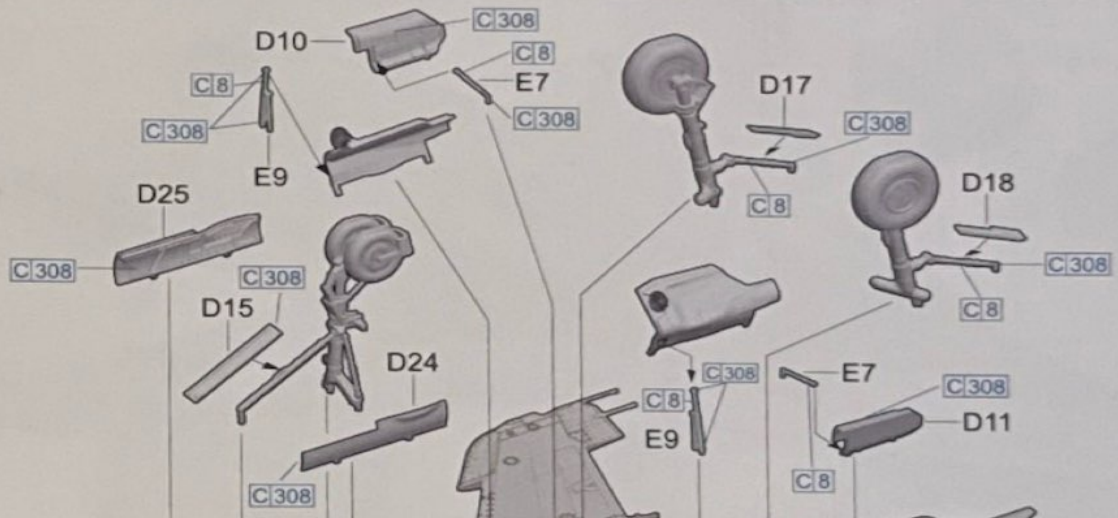
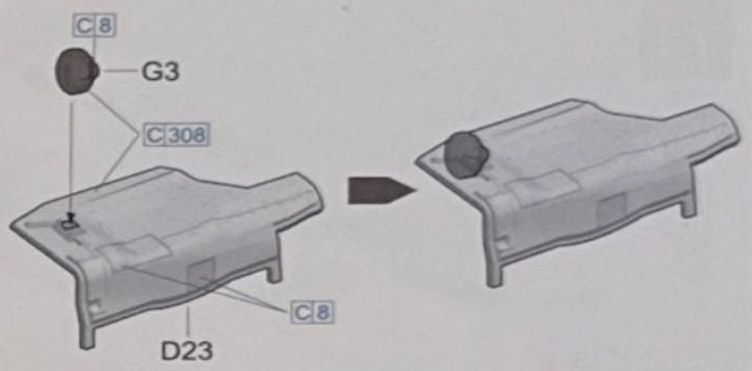
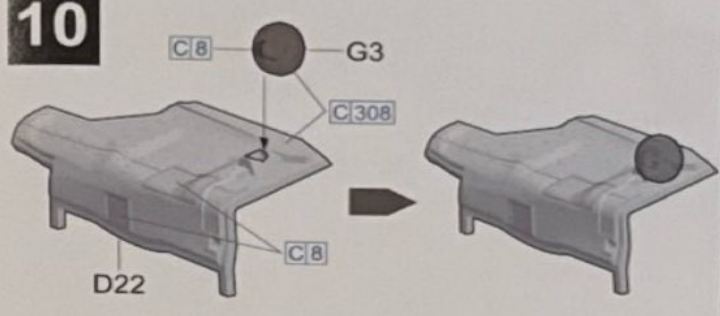

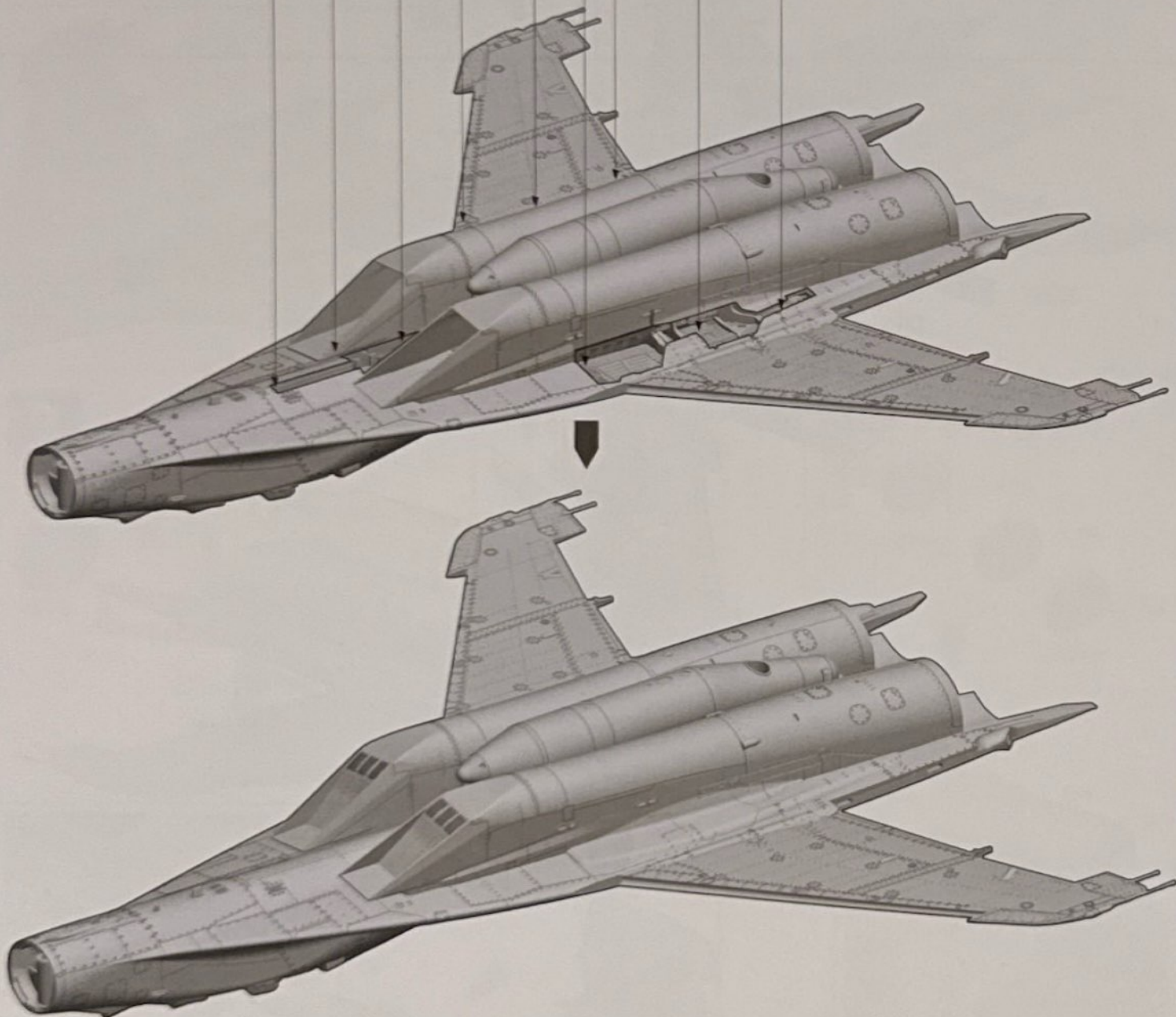
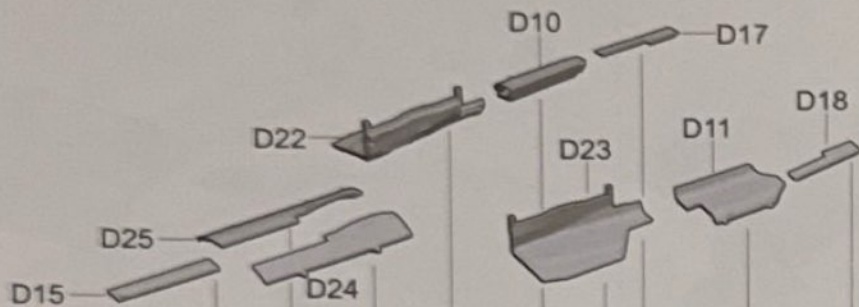

 Open State
打开状态

11

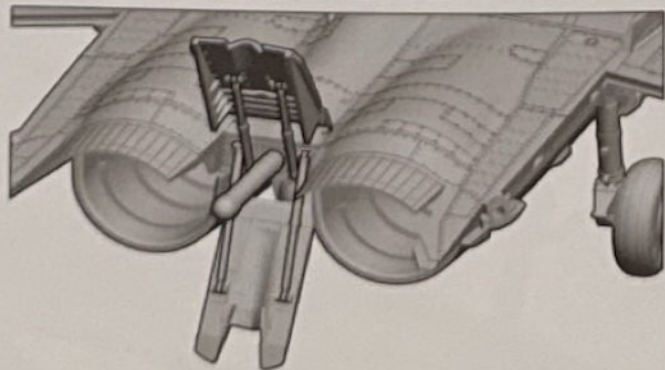
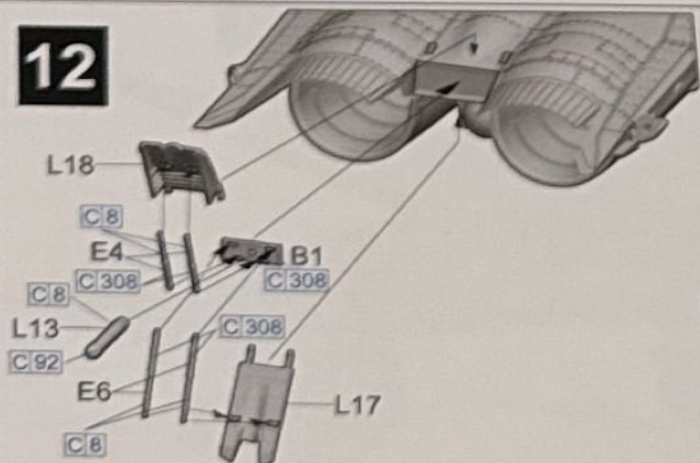

12



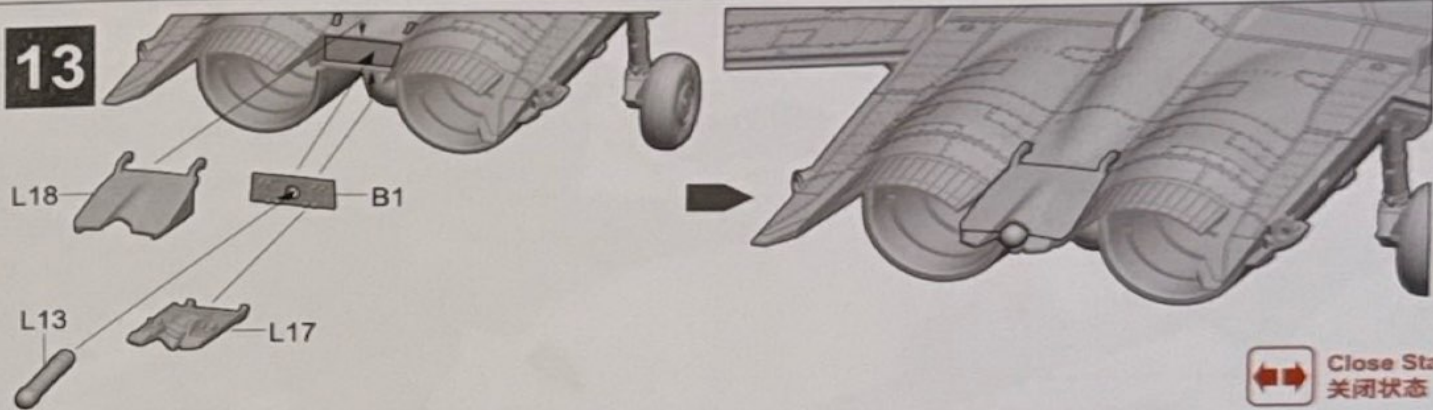

Open State
 打开状态

13

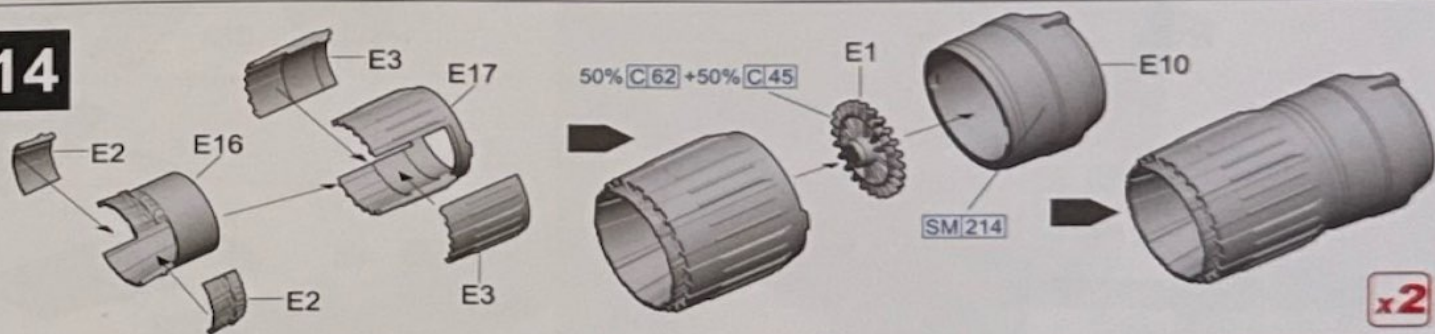

14



15

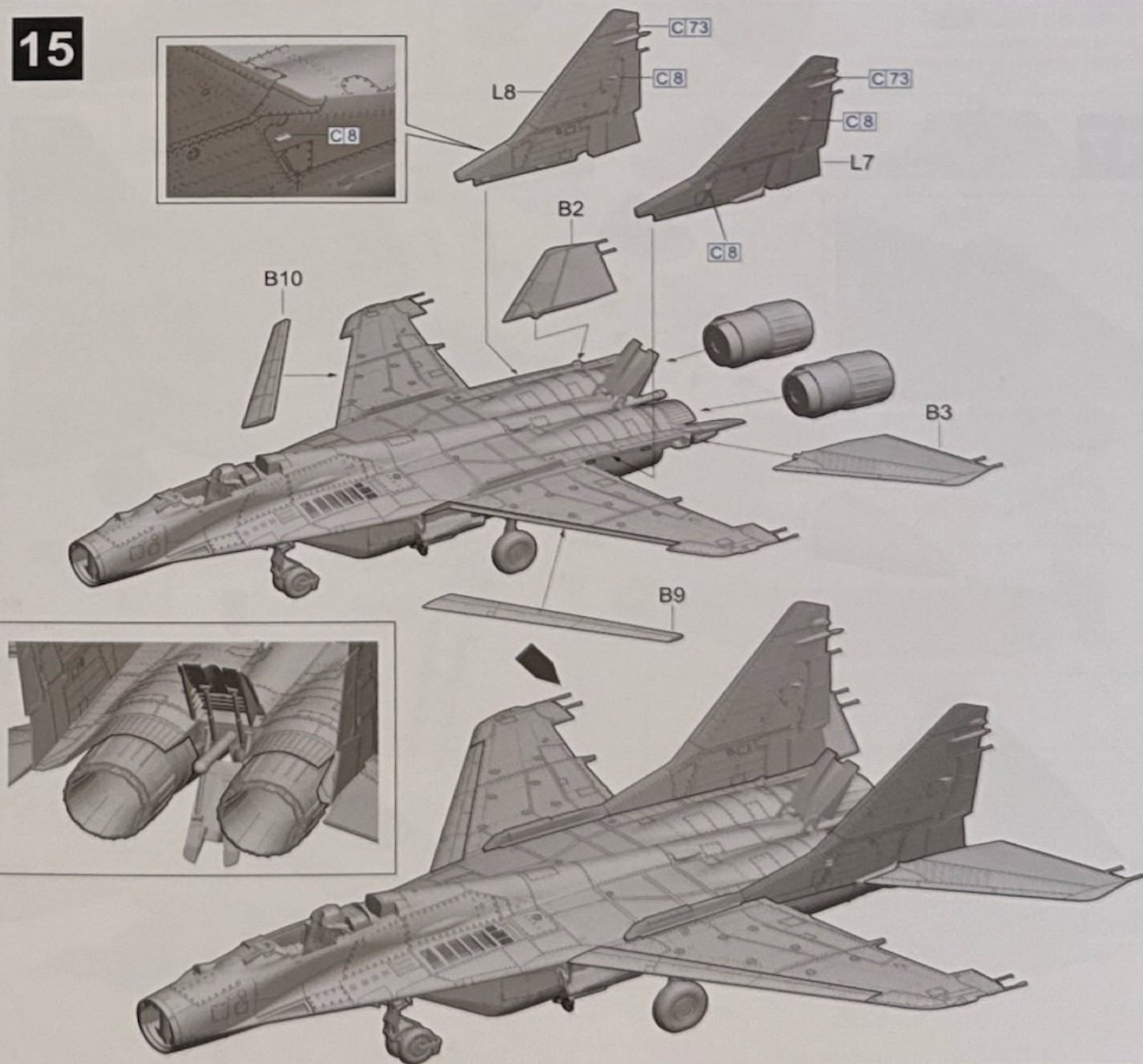

16

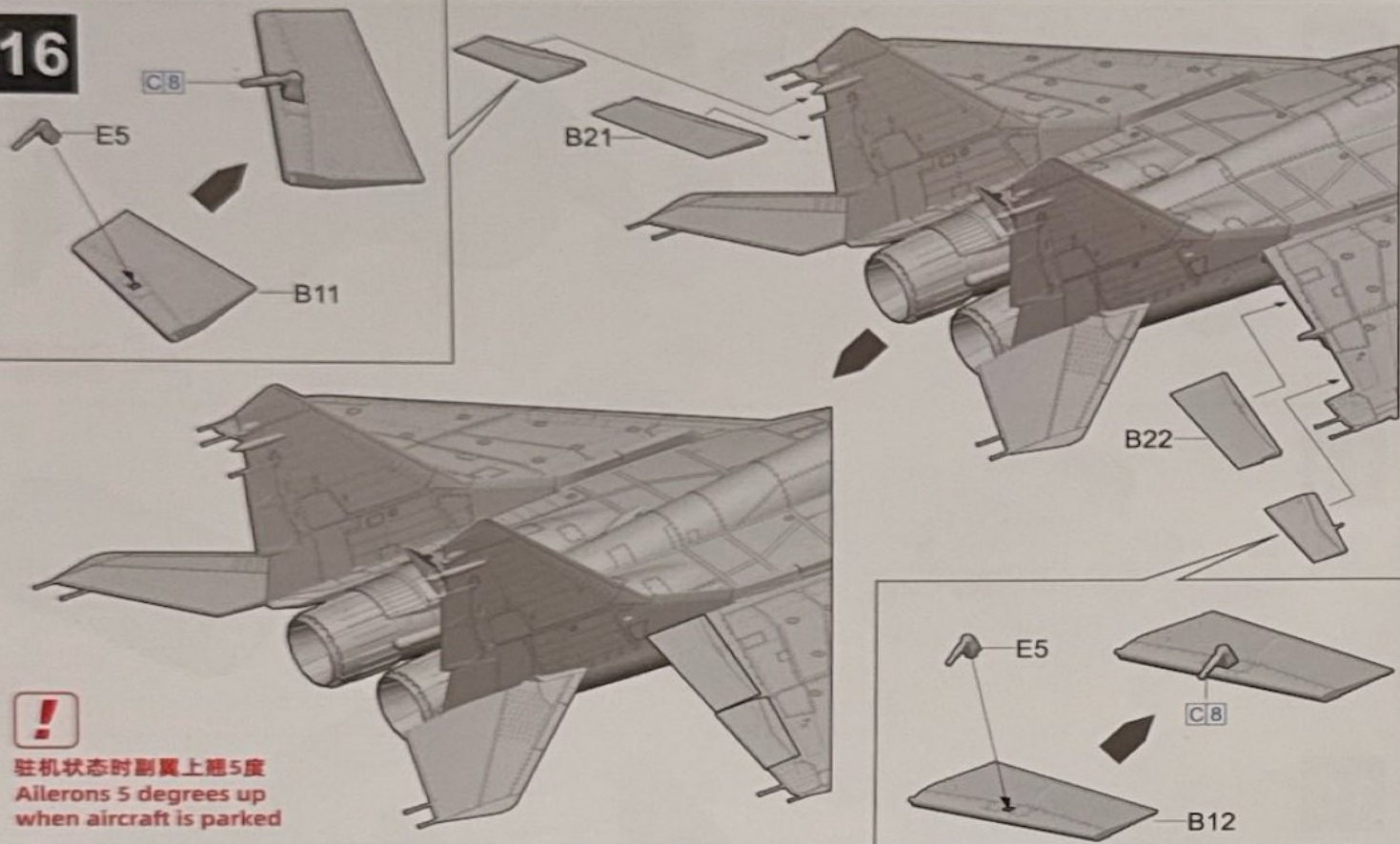

驻机状态时副翼上翘5度
Ailerons 5 degrees up
when aircraft is parked

17

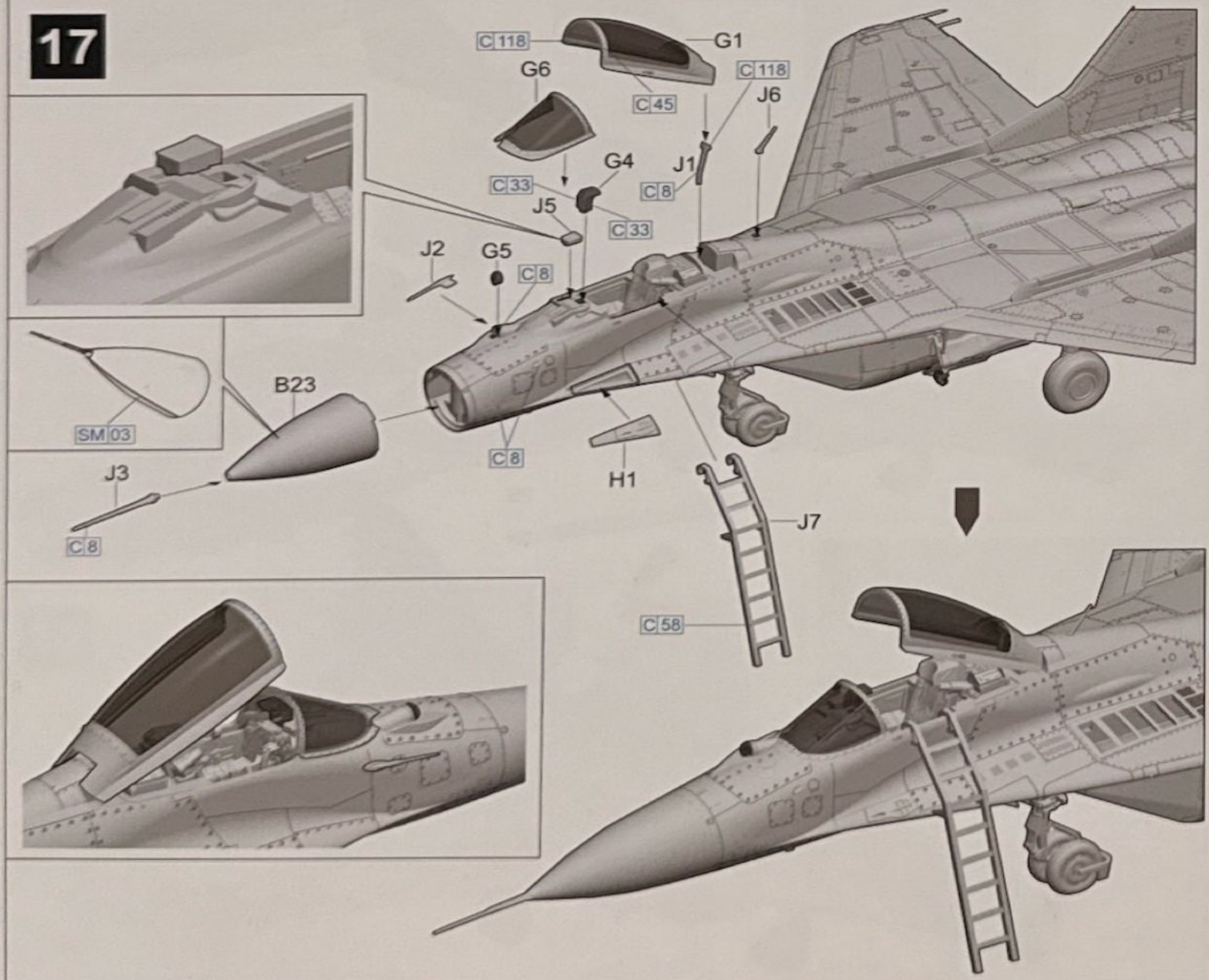

P-72 Pylon
P-72 挂架

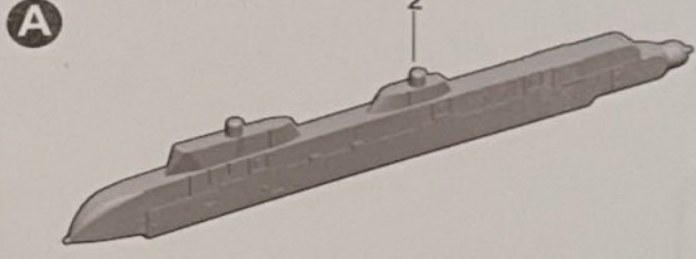

APU-470 Pylon
APU-470 挂架

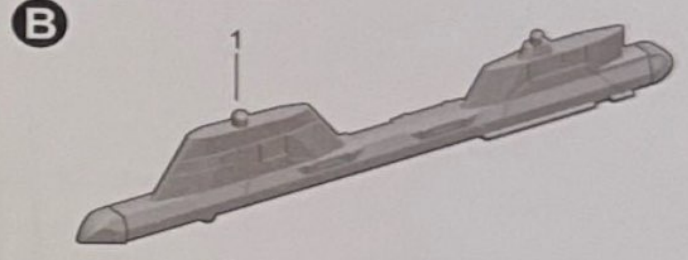

P-62 Pylon
P-62 挂架

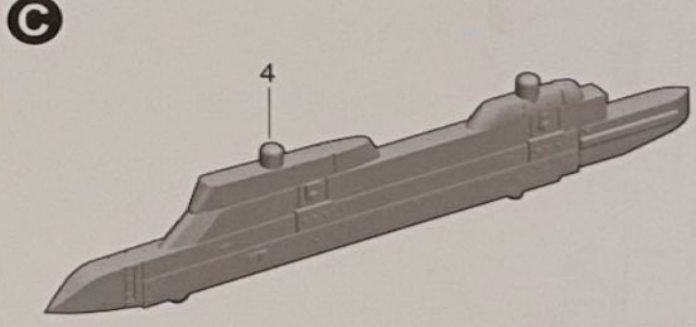

APU-470 Pylon
APU-470 挂架

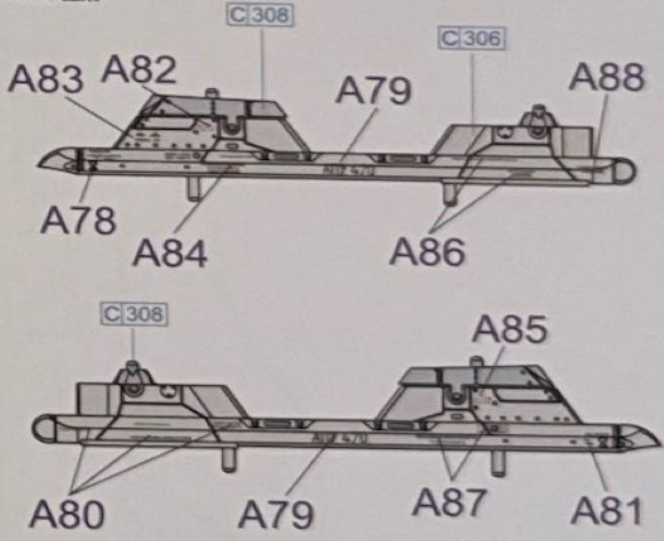

P-72 Pylon
P-72 挂架

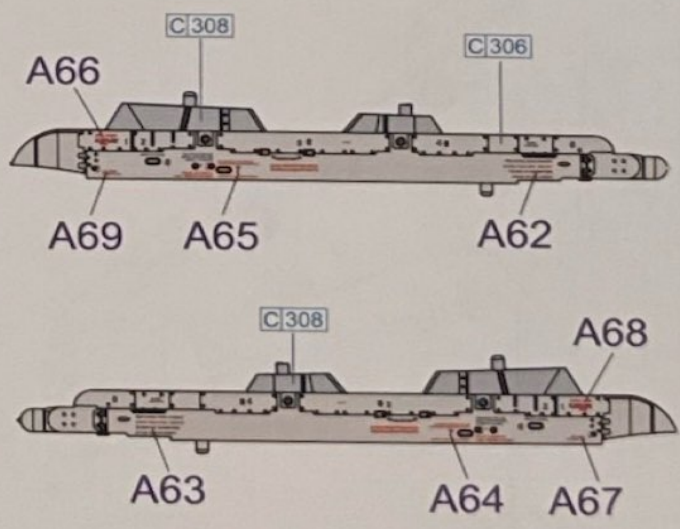

PTB-1500 Fuel Tank
PTB-1500 副油箱

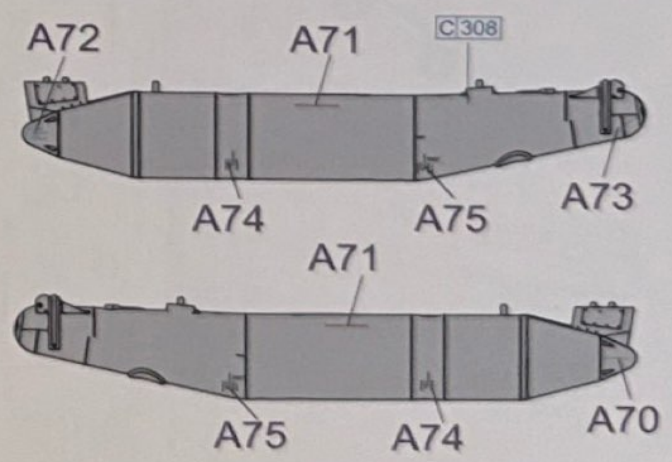

P-62 Pylon
P-62 挂架

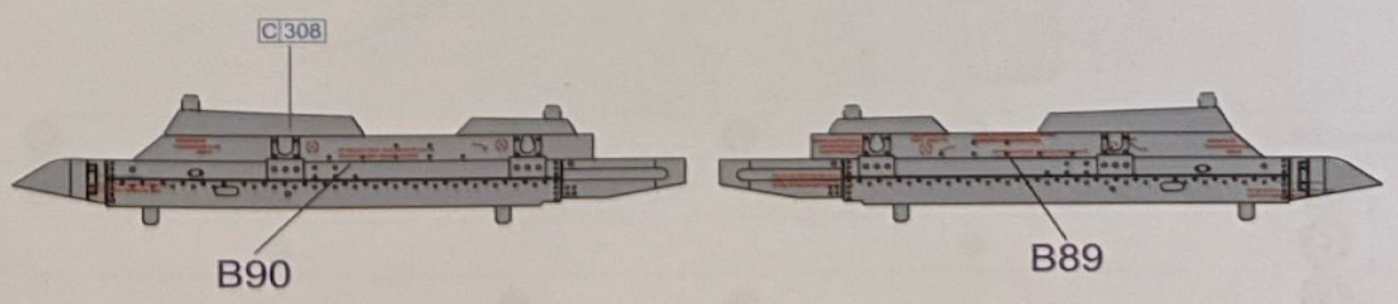

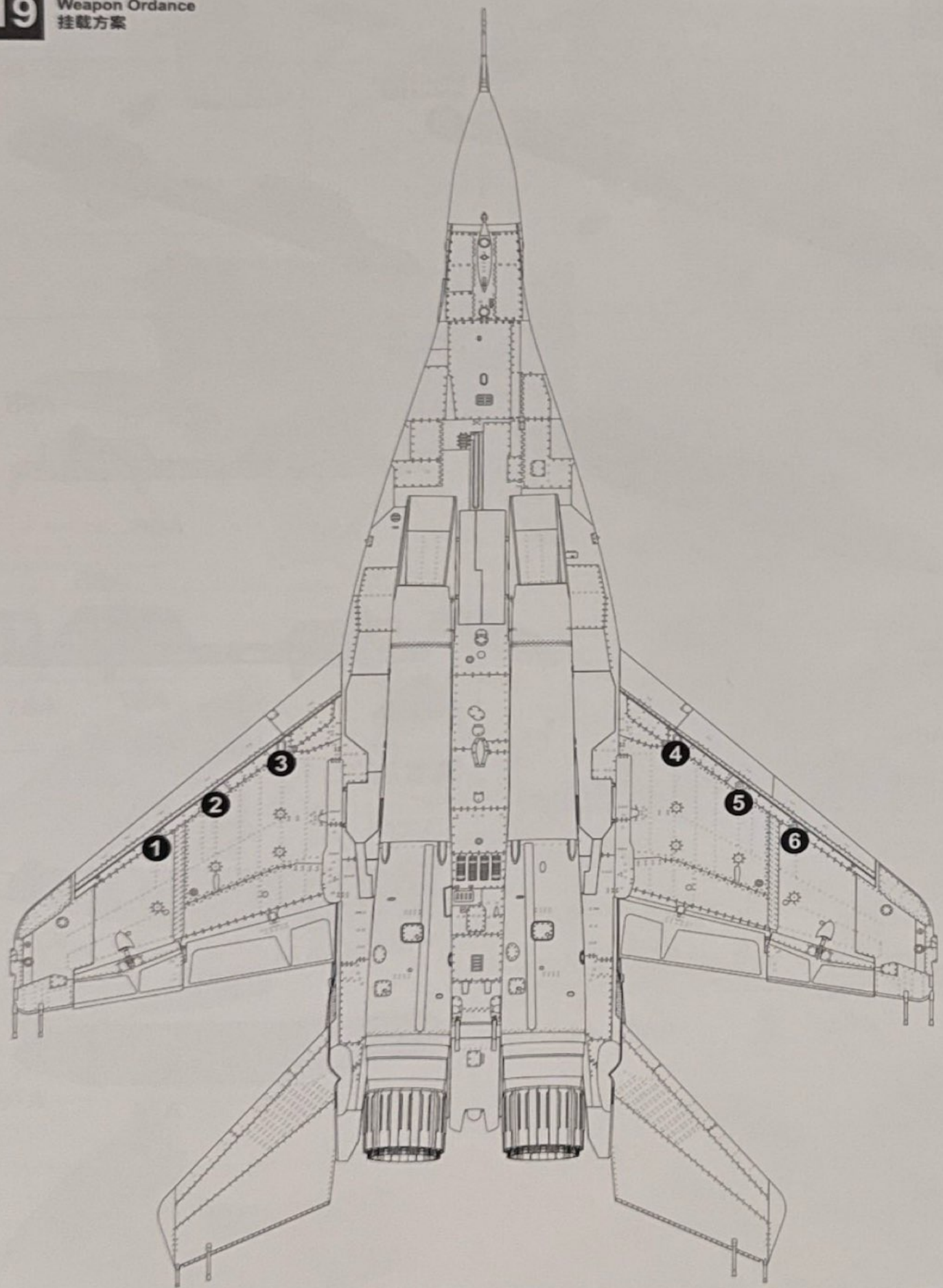

Hardpoint 挂点	1	2	3	4	5	6
A	●					●
B		●			●	
C			●	●		

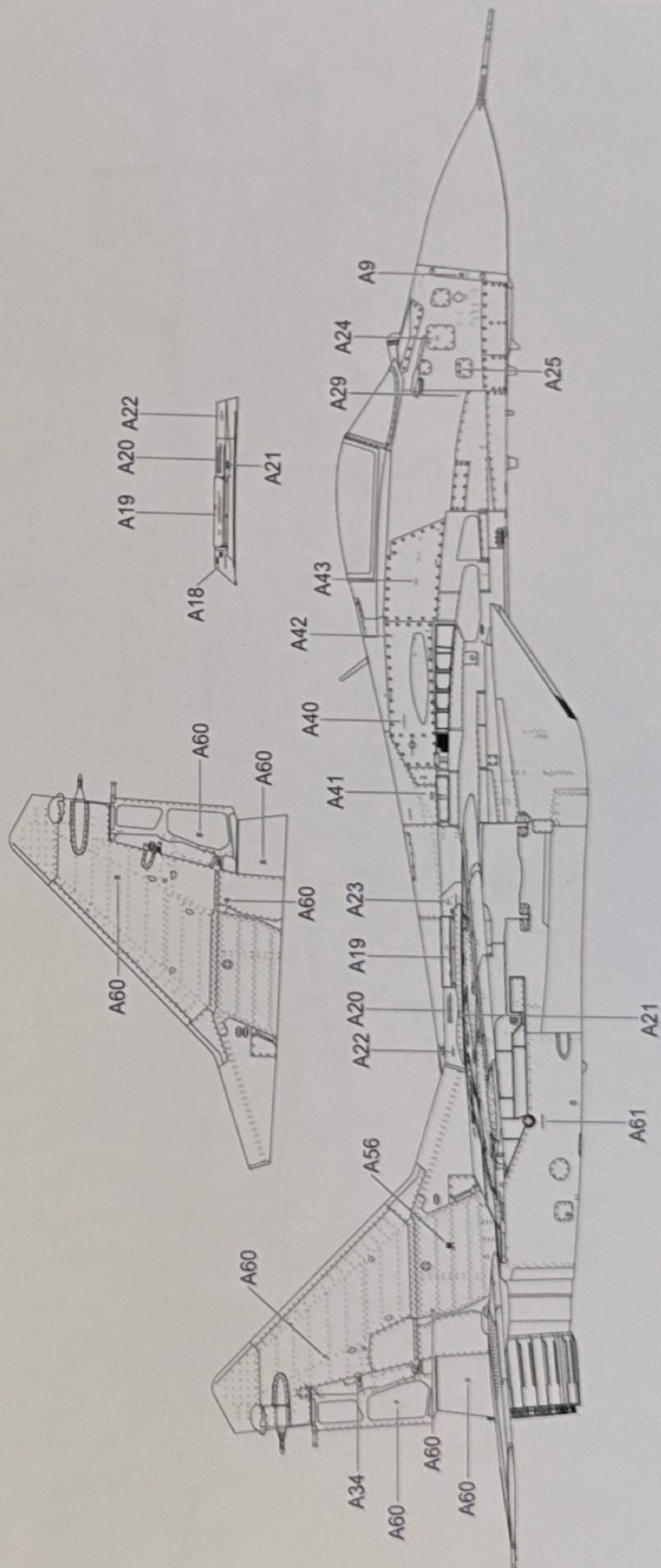

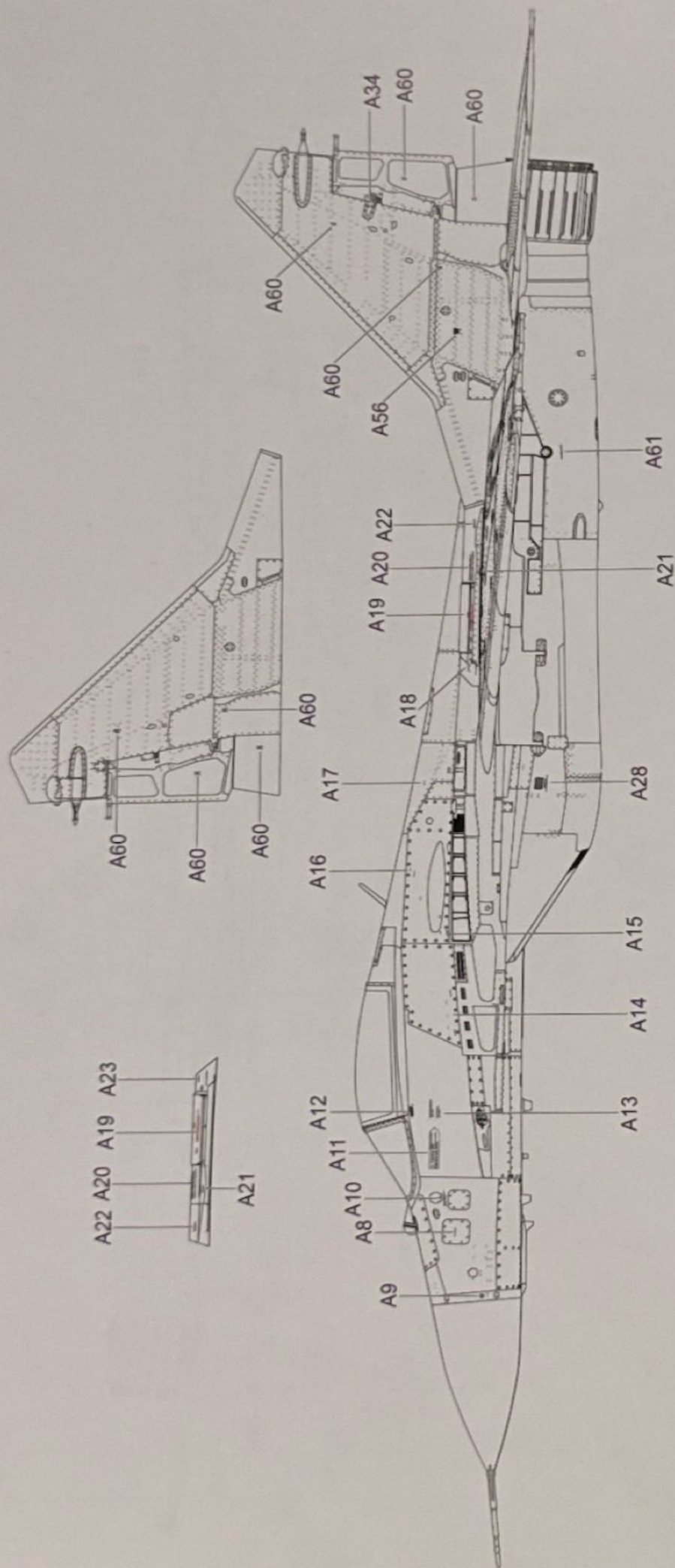

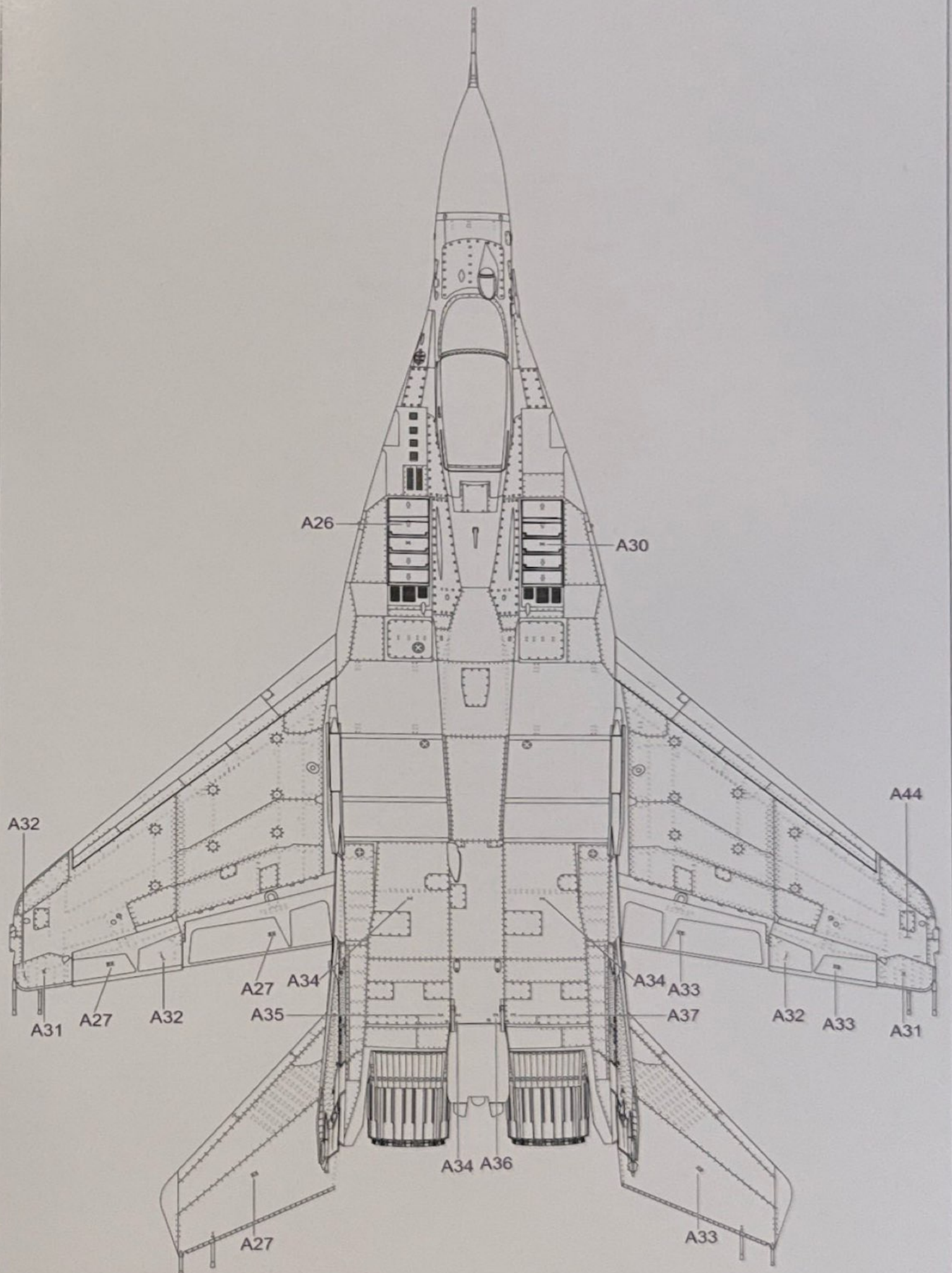

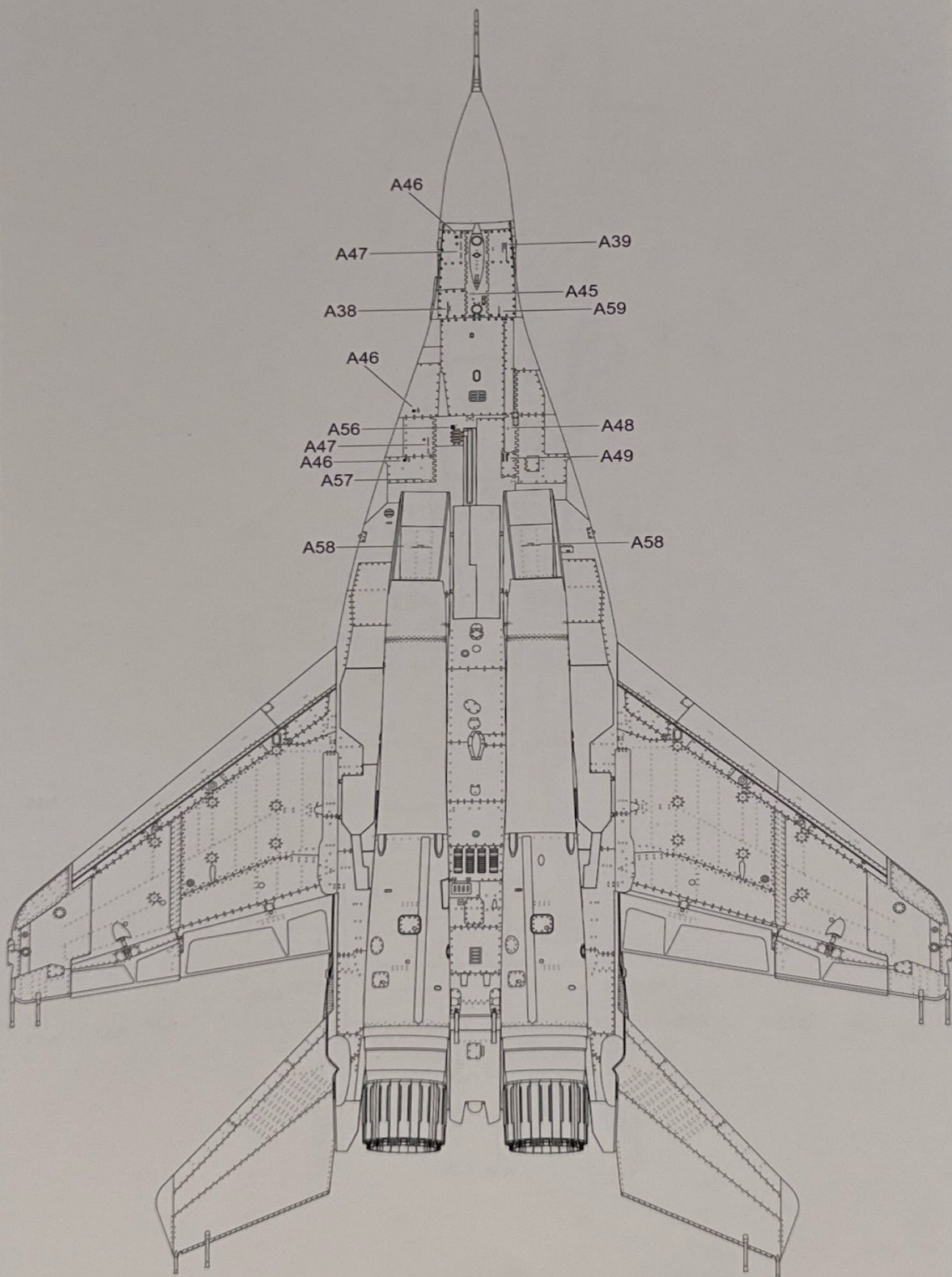



A Part x 1

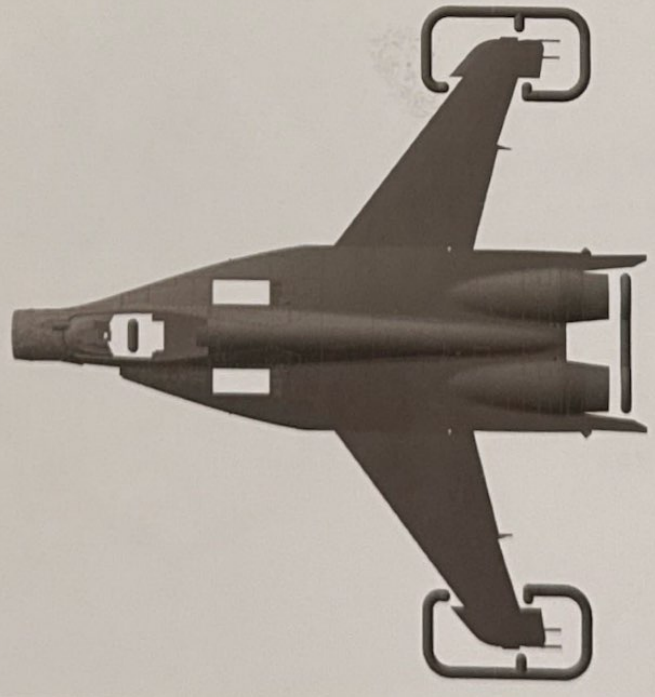

B Part x 1

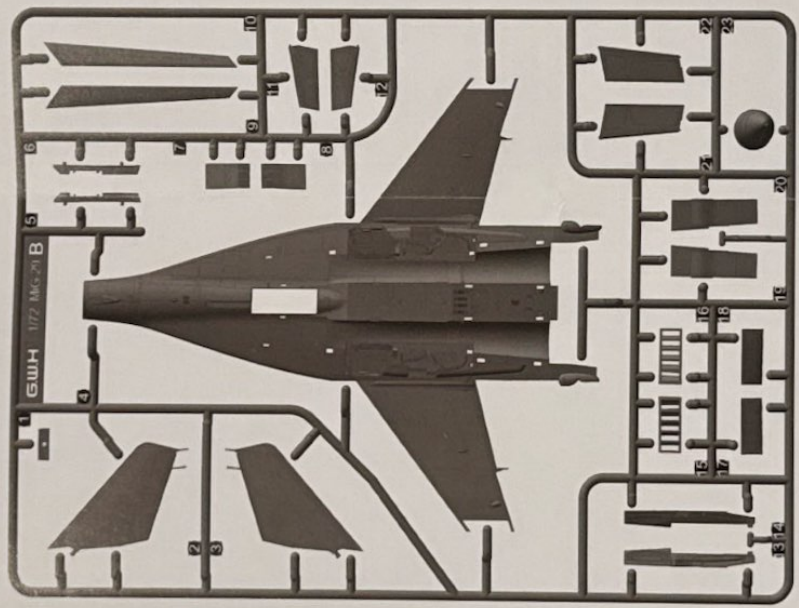

C Part x 1

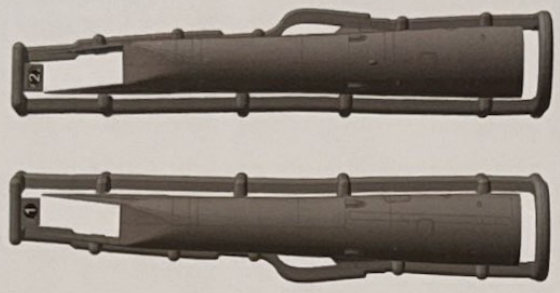

D Part x 1



L Part x 1

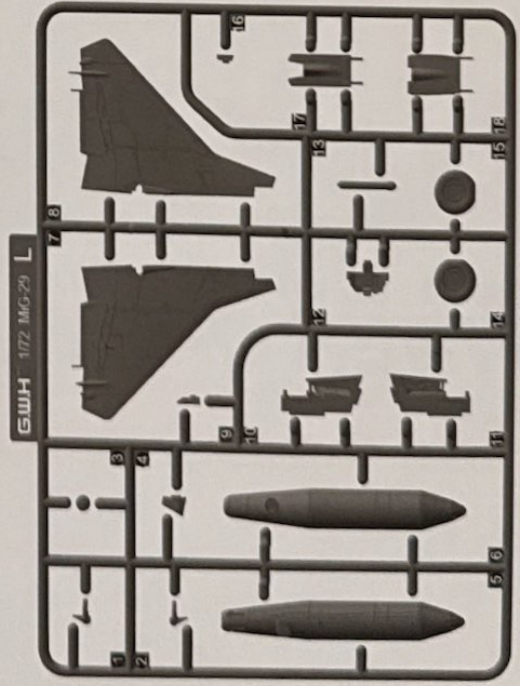

3D PART Part x 1



J Part x 1

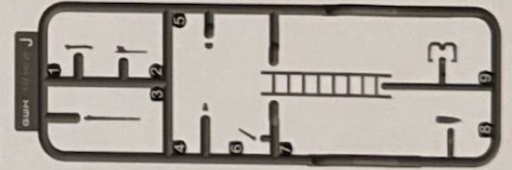

E Part x 2

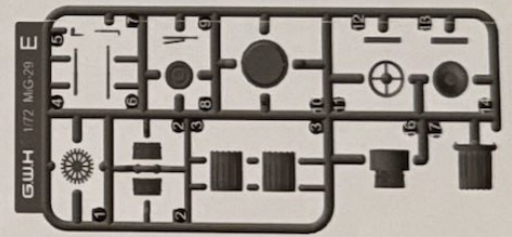

H Part x 1



G Part x 1

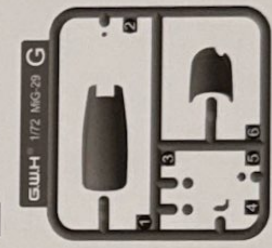

Decal C



Decal A

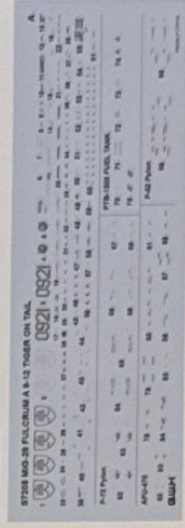

Decal B



阴影零件不使用
 DO NOT USE THE
 SHADOW PARTS

A MiG-29 Slovak air force 2014 special painting "digital camouflage with tiger on tail" 2014 MiG-29 斯洛伐克空军数码迷彩特别纪念涂装2014



! Please refer to scheme A for colour chart on common details, unless instructed specifically 通用细节颜色请参考涂装A, 除非单独标注

1/72 SCALE AIRCRAFT
SPECIAL PAINTING

MIG-29AS 9-12 LATE TYPE SLOVAK AIRFORCE
2014/2016 SPECIAL PAINTING
MIG-29AS 9-12 后期型 斯洛伐克空军数码迷彩特别纪念涂装限量

G.W.H. DIGITAL CAMOUFLAGE WITH
TIGER ON TAIL

B Mig-29 Slovak air force 2014 special painting
"digital camouflage with tiger on tail" 2016
MIG-29 斯洛伐克空军数码迷彩特别纪念涂装2016



! Please refer to scheme A for colour chart on common details unless instructed specifically
通用细节颜色请参考涂装A, 除非单独标注

G.W.H.[®] S7208 MiG-29 TIGER ON TAIL

