



'65 SHELBY GT-350R

KIT 2969

1/24 SCALE MASSTAB 1:24 ESCALA 1/24 1/32 ECHELLE

Maybe it looks just like a Mustang but it sure doesn't act like one. Horsepower is up, weight is down. Road holding and braking are vastly improved over a standard production Mustang. The result is a roaring, snarling, competition fastback that was designed specifically to dominate an entire SCCA production class. In its first year of competition, 1965, the Shelby GT-350R did just exactly that.

Up front in the GT-350R is a high performance version of the Ford 289 V-8, boosted from 271 hp up to 345 with the help of modifications like a Cobra hi-rise intake manifold, a Holley four-barrel carburetor, and a free-flow dual exhaust system. An enlarged high-capacity aluminum sump holds oil, which is routed thru an oil cooler mounted in the nose behind the big air scoop under the grille. Wide racing rubber is mounted on big fifteen-inch, five-spoke magnesium wheels. A heavy-duty four-speed gear box is standard equipment, as is a limited-slip differential.

As if that weren't enough, the GT-350R is a whole lot lighter than your garden-variety Mustang - about 400 lbs. In fact, at 2550 lbs., this 60s era vintage racer weighs just as much as a modern Trans Am car. A number of items account for this: Fibreglass hood and front splash pan, no bumpers, plastic side and rear windows, lighter racing seat, and cast aluminum used in places like the oil pan and transmission case. That special, ducted rear window helps to vent air trapped inside the gutted racing interior. All these features allow the Shelby GT-350R to run a 0 to 60 time of only 5.5 seconds, and a top speed of 145mph.

Less than 60 of these cars were built; all strictly for competition. Your Monogram model captures all the special features mentioned to build your own replica of this historic, championship winning road racer.

2969 M 0200

READ THIS FIRST

- Study the assembly drawings.
- Each plastic part is identified by a number.
- In the assembly drawings, some parts will be marked by a star (*) to indicate plated plastic.
- Scrape plating from areas to be cemented
- Check the fit of each piece before cementing in place.
- Do not use too much cement to join parts.
- Use only cement for polystyrene plastic.
- Models may be painted to match photos on box.
- Allow paint to dry thoroughly before handling parts.
- Scrape paint from areas to be cemented.
- For better paint and decal adhesion, wash the plastic parts in a mild detergent solution. Rinse and let air dry.

- Jedes Plastikteil ist durch eine Nummer gekennzeichnet.
- Beschichtete Teile sind in den Zeichnungen mit einem Stern (*) bezeichnet.
- Die Beschichtung muss von allen Klebestellen vorher entfernt werden.
- Die Teile vor dem Verkleben ungeleimt zusammenhalten um ihrem Passitz zu prüfen.
- Klebstoff nicht zu dick auftragen.
- Nur Modellbaukleber für Polystyrol verwenden.
- Man kann das Modell nach den Fotos auf der Schachtel anstreichen.
- Bemalte Teile vor der Weiterverwendung gut trocknen lassen.
- Die Farbe muss von allen späteren Klebestellen abgeschabt werden.
- Damit sie Farbe und die Abziehbilder kleben sind die Plastikteile in einer milden Seifenlauge zu waschen. Dann abspülen und an der Luft trocknen lassen.

LEA ESTO ANTES DE EMPEZER

- Estudie los dibujos de ensamblaje.
- Cada pieza de plástico se identificapor un número.
- En los dibujos de ensamblaje, algunos número de los piezas están marcados con una estrella (*) para indicar plástico laminado.
- Raspe el laminado de las superficies que serán pegadas.
- Verifique que cada pieza encaje bienantes de posición.
- No use demasiado pegamento parauni las piezas.
- Use unicamente pegamento paraplastico de poliestirena
- El modelo puede pintarse de acuerdo con las fotografias de la caja.
- Permita que se seque la pintura completa mente antes de tocar las piezas.
- Raspe la pintura de las superficies que serán pegadas.
- Para una mejor fijacion de la pintura y de las calcomanias lánvese las piezas plásticas en una solución de detergentesuave. Enjuague y dejense secar alaire.

LISEZ CE QUI SUIT AVANT DE COMMENCER LE MONTAGE

- Etudier les schémas d'assemblage.
- Chaque piece plastique porte un numéro d'identification.
- Sur les schémas d'assemblage les pieces dont le numéro comporte une asterique (*) sont en plastique chromé.
- Grattez le chromage sur les surfaces a coller.
- Contrôler que chaque piece soit bien cinfirmé avant de la coller a sa place.
- N'utilisez pas trop de colle pour réunir les pieces.
- Utilisez uniquement une colle spéciale pour polystyrene.
- Le modele peut étre peint conformement aux photos sur la boite.
- Laissez sécher la peinture completement avant de manipuler les pieces.
- Grattez la peinture sur les surfaces devant étre collées.
- Pour assurer la meilleure adhesion possible de la peinture et des décalomanies, laver les pieces de plastique avecune légère solution savonneuse. Rinse et laissez sécher a l'aire.

ALLGEMEINE HINWEISE

- Die Anordnung der Bauteile ist den Zeichnungen der Anleitung ersichtlich.



REPEAT SEVERAL TIMES
A REPETER PLUSIEURS FOIS
ARBEITSGANG MEHRMALS WIEDERHOLEN
REPITA VARIAS VECES



DO NOT CEMENT
NE PAS COLLER
NICHT KLEBEN
NO USE PEGAMENTO



DECAL (DIP IN WATER)
DECALCOMANIE (A PLONGERDANS L'EAU)
ABZIEHBILD
DECALCOMANIA (MOJE CON AGUA)



REMOVE AND THROW AWAY
A RETIRER ET JETER
ENTFERNEN (ABFALL)
QUITE Y TIRE

FLAT BLACK	NEGRO APAGADO	GLANZLOSES SCHWARZ	NOIR TERNE
SATIN BLACK	NEGRO MATE	HALBGLANZENDES SCHWARZ	NOIR MAT
AMBER	AMBAR	BERNSTEINFARBEN	AMBRE
RED	ROJO	ROT	ROUGE
BROWN	MARRON	BRAUN	BRUN
BRONZE	BRONCE	BRONZE	BRONZE
ALUMINUM	ALUMINIO	ALUMINIUMFARBEN	ALUMINIUM
STEEL	METALICO	METALLIC	METALLIC
SILVER	PLATA	SILBERN	ARGENT

REVELL-MONOGRAM MODELS, INC. Morton Grove, IL Copyright ©1994 All rights reserved. Made in U.S.A.

If you have any problems building this model, call our modeling tips hotline at:

(800) 833-3570

Every effort has been made to create and manufacture a model kit that is the finest available. If a part may be missing, please write to:

MONOGRAM MODELS,
Consumer Service Department
301 North Third Avenue
Des Plaines, Illinois 60016

Be sure to include the kit number, part number, description, and your return address.

BN

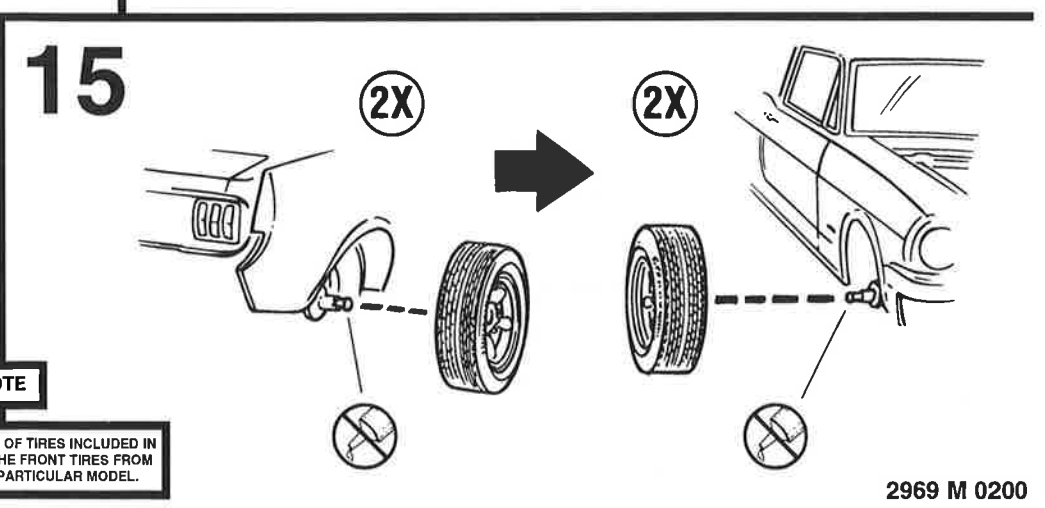
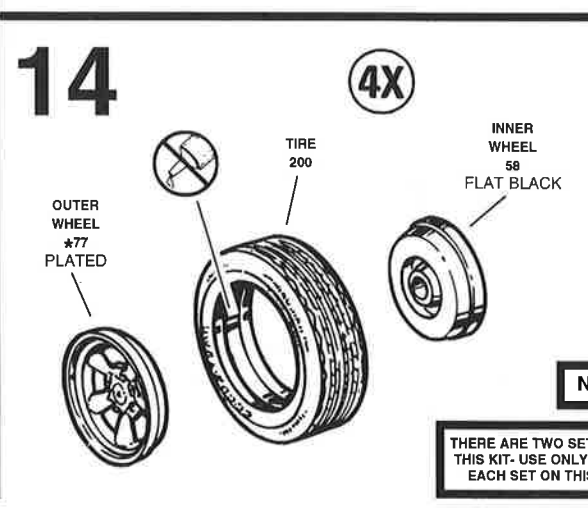
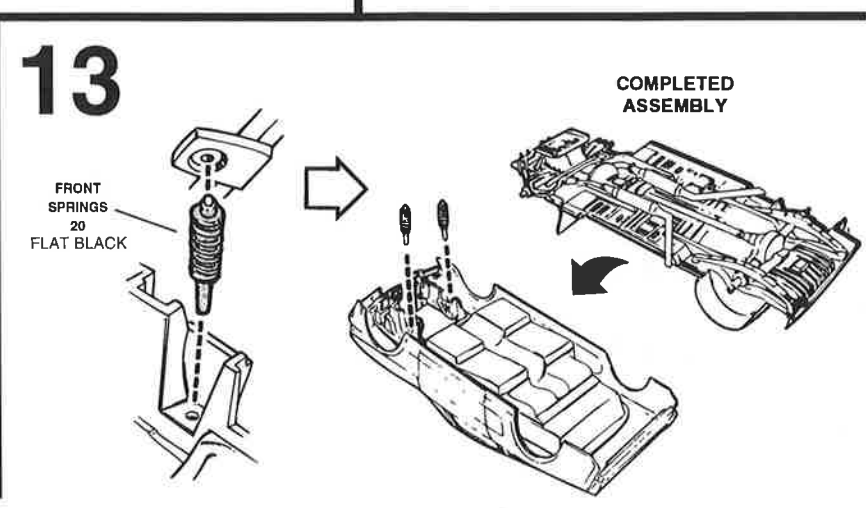
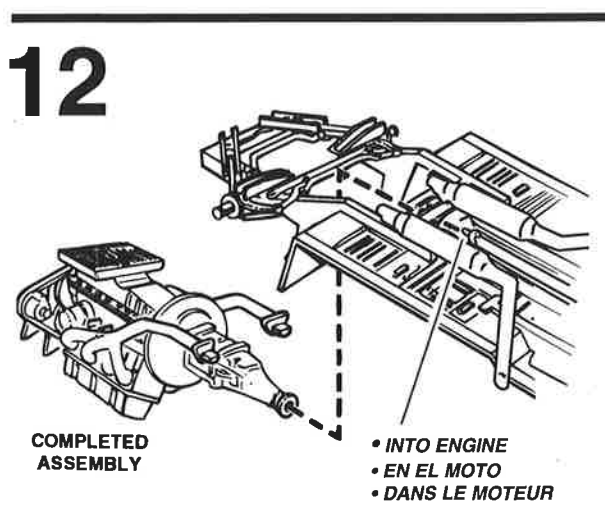
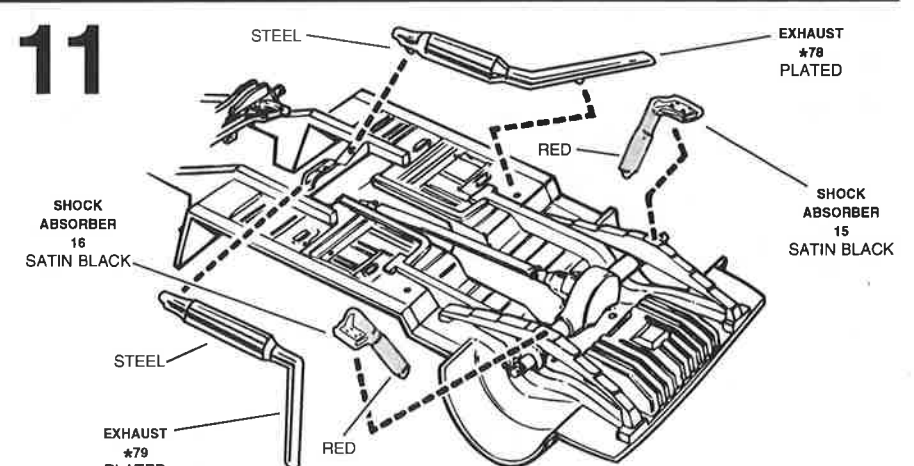
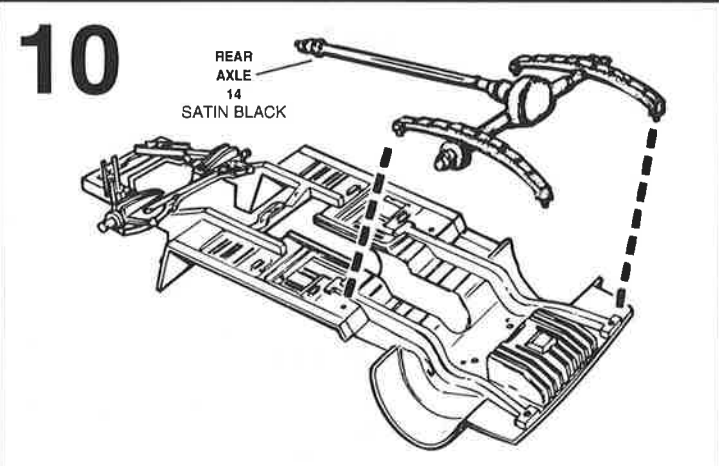
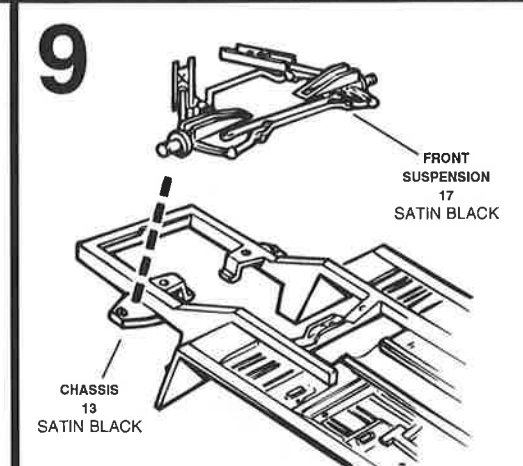
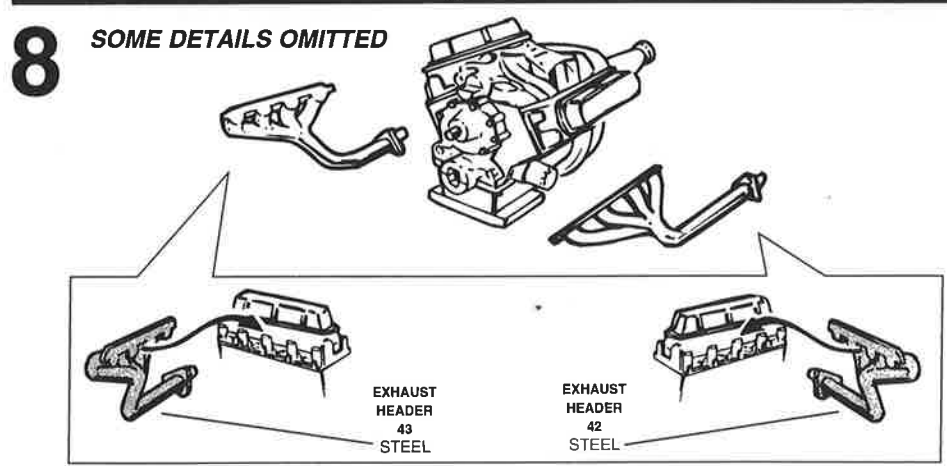
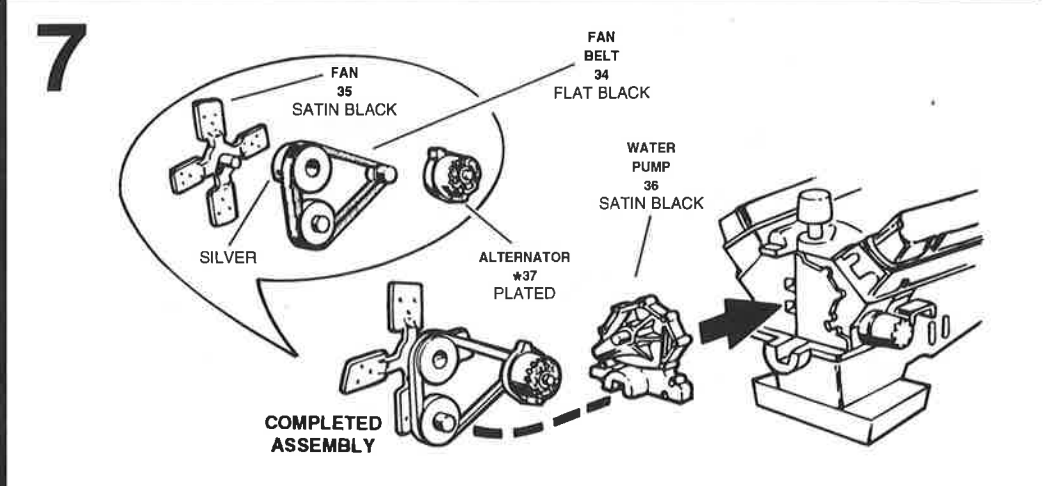
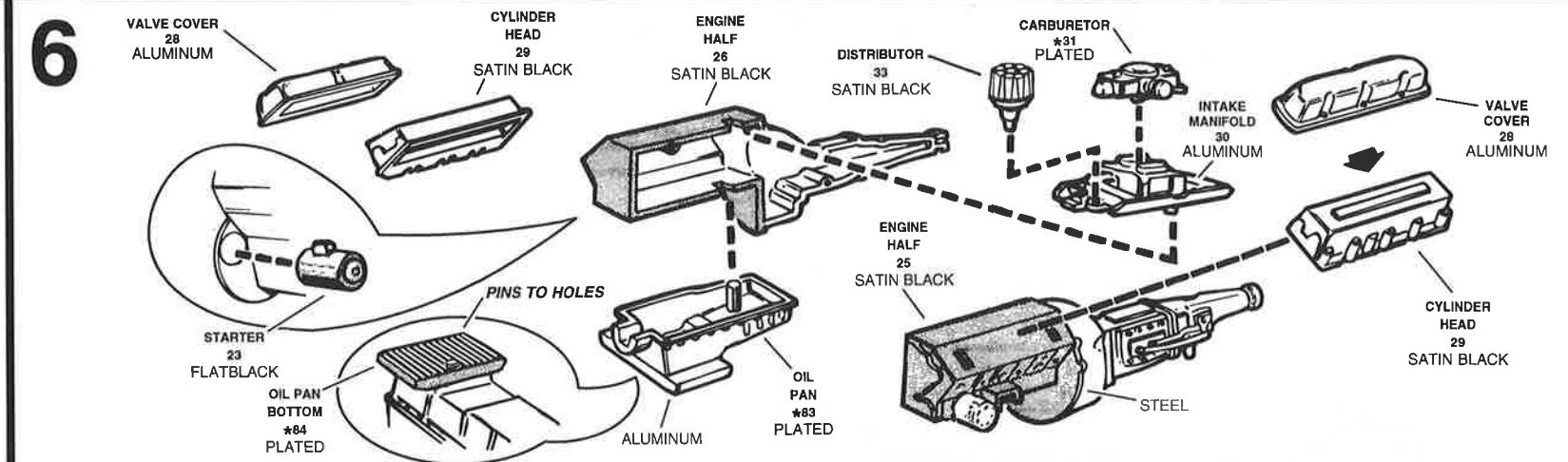
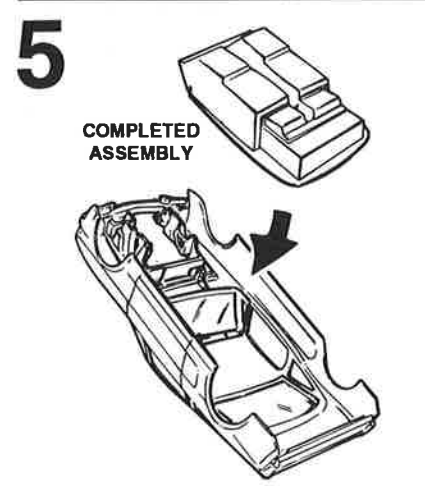
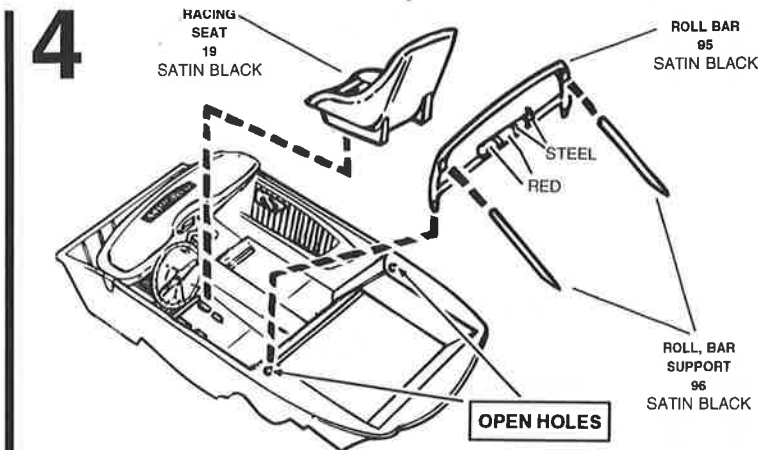
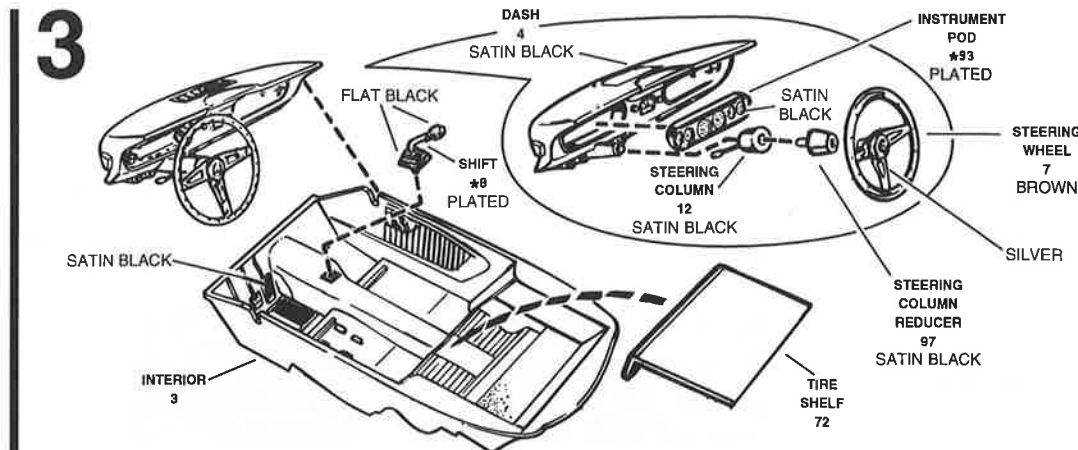
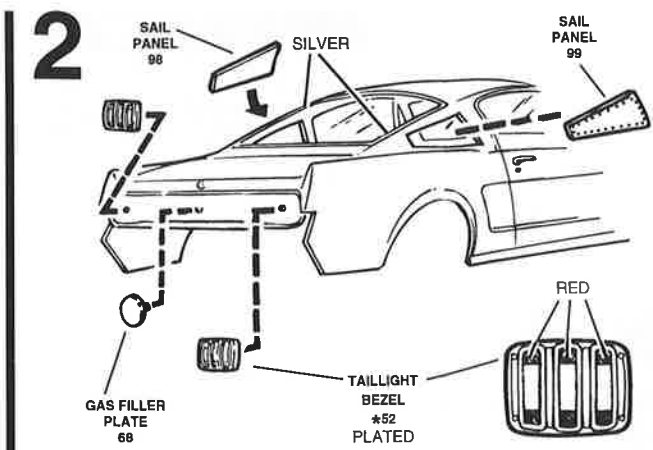
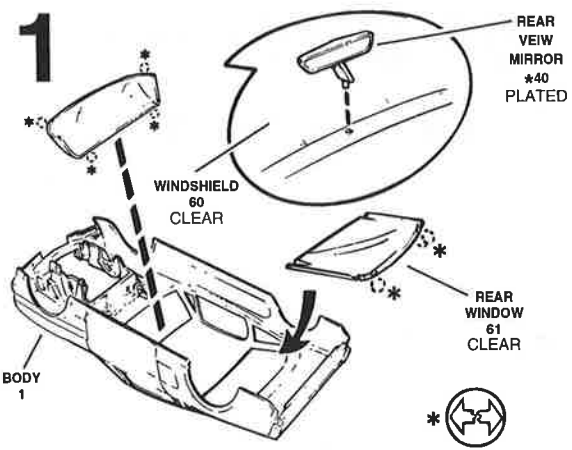

16

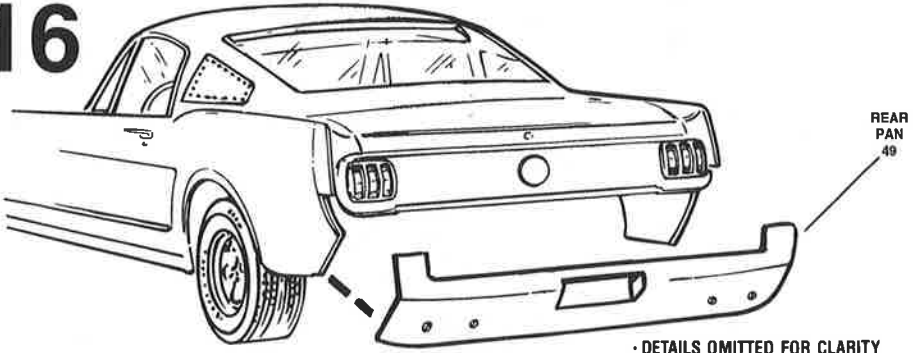

• DETAILS OMITTED FOR CLARITY

17

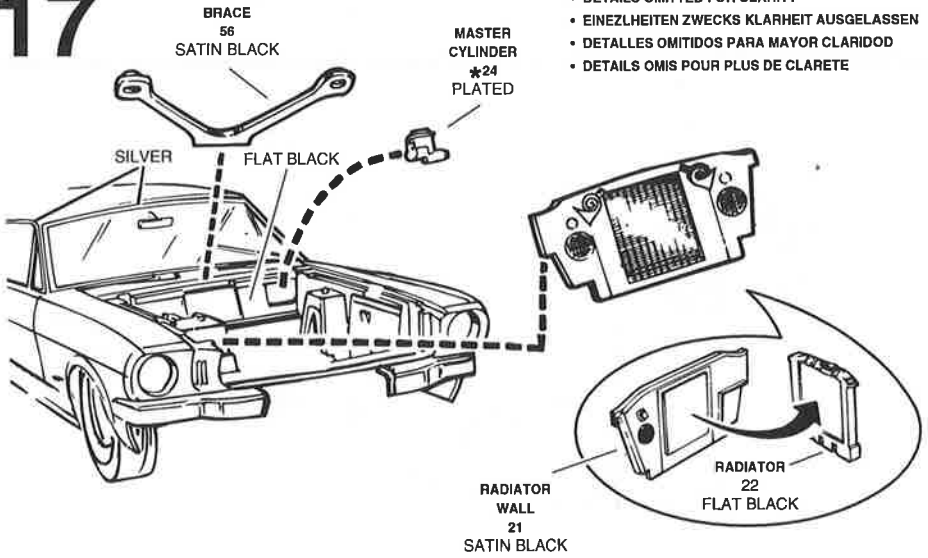

- DETAILS OMITTED FOR CLARITY
- EINZELHEITEN ZWECKS KLARHEIT AUSGELASSEN
- DETALLES OMITIDOS PARA MAYOR CLARIDAD
- DETAILS OMIS POUR PLUS DE CLARETE

18

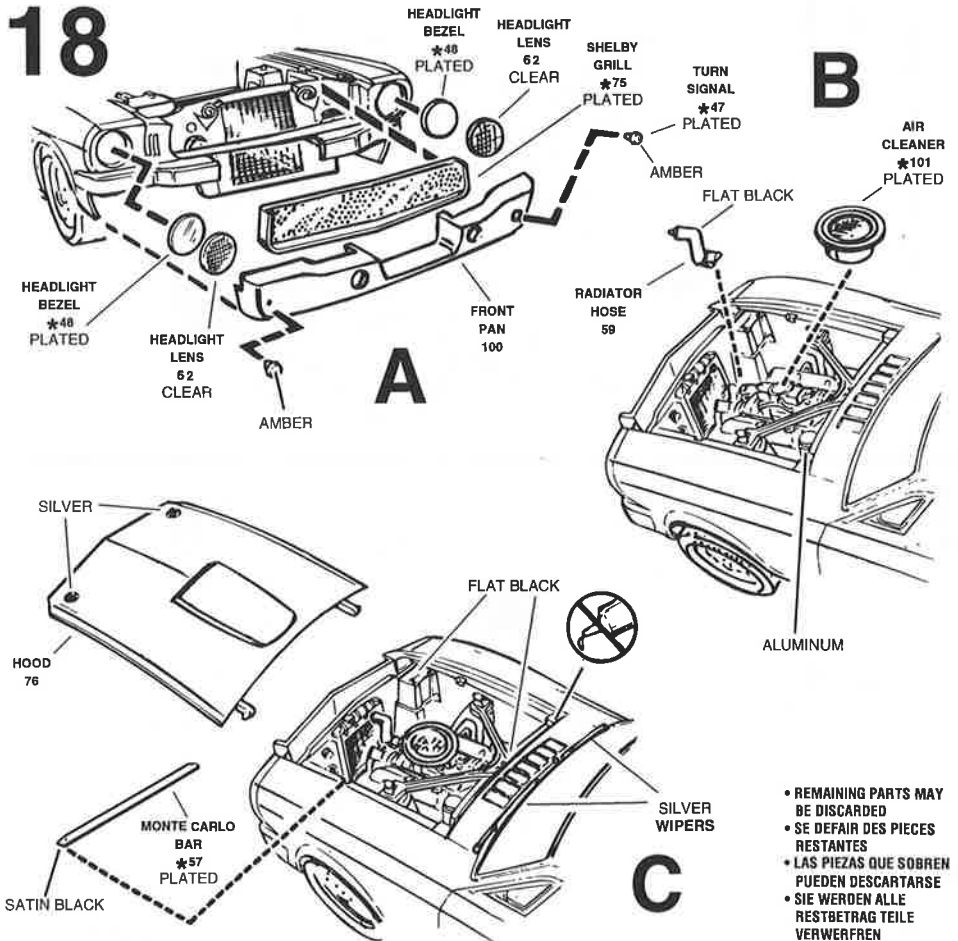

- REMAINING PARTS MAY BE DISCARDED
- SE DEFAIR DES PIECES RESTANTES
- LAS PIEZAS QUE SOBREN PUEDEN DESCARTARSE
- SIE WERDEN ALLE RESTBETRAG TEILE VERWERFREN

