

A-6E TRAM Intruder

美国A-6E TRAM “入侵者” 攻击机

READ BEFORE ASSEMBLY:

- This kit is not recommended for inexperienced modelers or for children under 14 years of age
- Study and understand these instructions thoroughly before beginning assembly
- When needed, remove photo-etch parts carefully using a modeling knife or photo etch sprue cutter, being careful not to damage or lose small parts.
- Take extra care in handling photo etch parts in order to avoid injury
- Apply instant cement sparingly to photo etch parts where instructed
- Tools recommended(not included in kit):Plastic and instant cements,sprue cutters,long nose pliers,modeling knife, small files, tweezers, pin vise & scissors. Soft cloth and sandpaper will also assist in construction
- Glue and paint are not included in the kit. Use plastic cement and hobby paints only. Color guide for purchasing paint is included in the kit.
- Keep out of reach of children. They must not be allowed to ingest small parts or handle plastic bags in any way.

*说明书中含有重要信息，应保留。 Please Keep instruction since it contains important information.

· 装配之前仔细阅读

- 小心用模型锉刀锉平所有零件表面的注射浇口。
- 小心用刀片切下蚀刻片零件，不要遗失小零件。
- 用强力快干胶水粘合蚀刻片零件和金属轴。过量的快干胶水使用可能导致可动零件会粘住，小心涂胶。
- 取蚀刻片时应特别注意安全，防止利边划伤手指。
- 某些零件表面需贴水上贴纸，请选择在装配的同时进行。
- 推荐模型工具(自备)：胶水，水口剪刀，长咀钳，刀片，锉刀，镊子钳，钻，剪刀，瞬间快干胶。
- 软布同砂纸同时也是所需工具。
- 请使用塑料胶水和油漆，模型内不含。
- 谨防小孩吸吮塑料零件，或者将塑料袋套在头上，制作时应将套材远离小孩接触。
- 本产品不适合14岁以下没有经验的模型爱好者。

水贴纸的使用:

1. 从水贴纸上剪下印花;
2. 将印花放入温水中浸10秒, 然后放在干净布上。
3. 拿着印花纸板将印花移到模型上;
4. 手指蘸水将印花移到适当的位置;
5. 用软布轻压印花直至水干, 气泡消失。

DECAL APPLICATION:

1. Cut decals from sheet as needed
2. Dip the decal in warm water for about 10 seconds and then place on soft clean cloth.
3. Hold the decal backing sheet edge and gently slide the decal onto the model in its proper position.

4. While still wet,decal can be adjusted for better fit on model by dampening it gently with your finger.
5. When placed in the proper position,gently press decal down with a soft cloth until excess water and air bubbles are gone.
6. Allow decal to dry completely before handling model



部品图 Parts

A

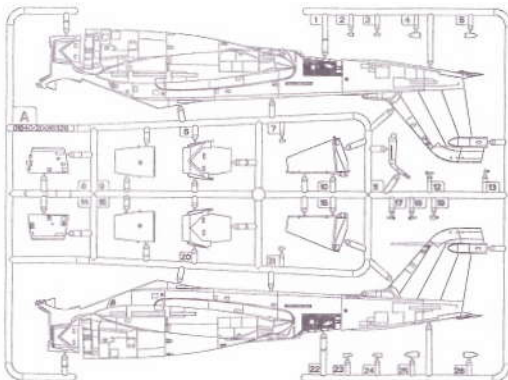

C

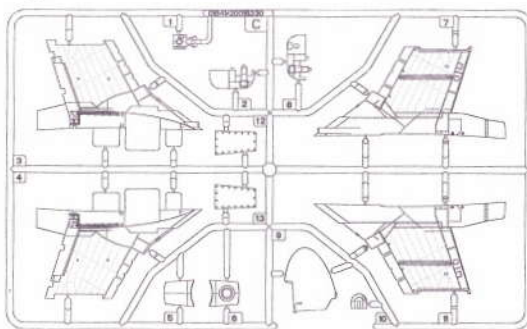

D

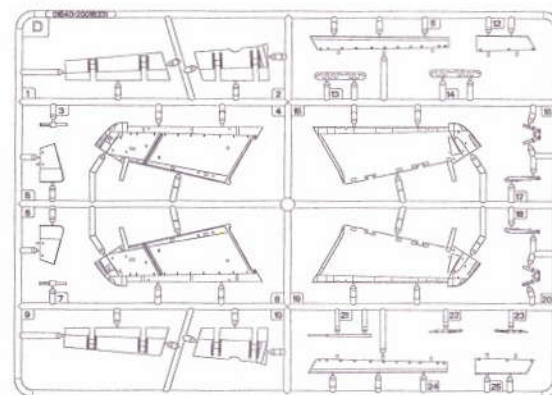

E

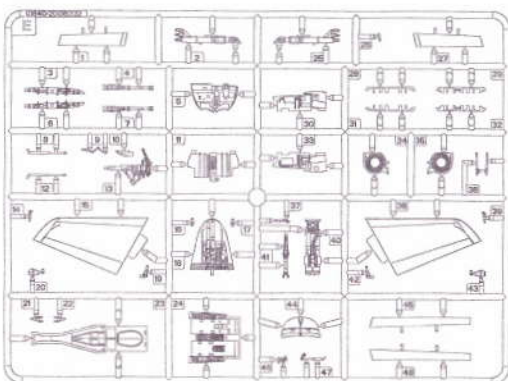

F

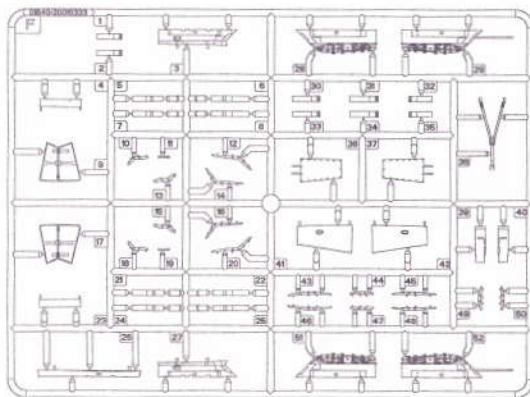

J

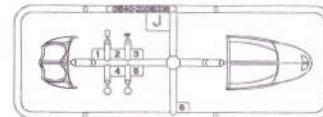

G x 2

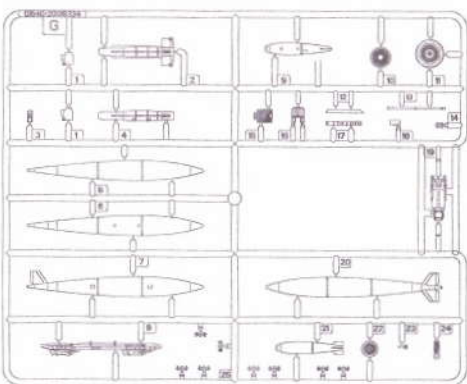

H x 2

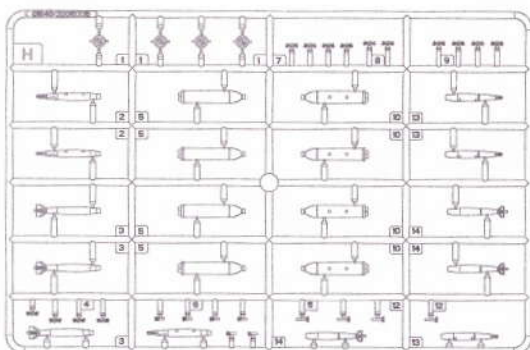

《水贴》
Decal

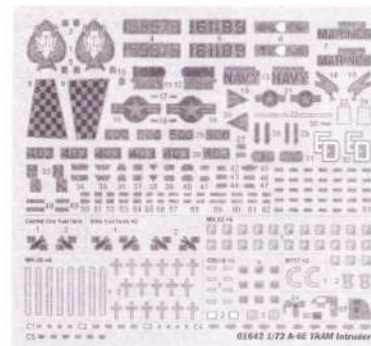

《遮盖纸》
Die-cut mask

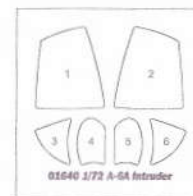

不用的部件: A18, C2, C5, D21, E8, E12,
Unused parts F28, F51, F36, F37, H8

1

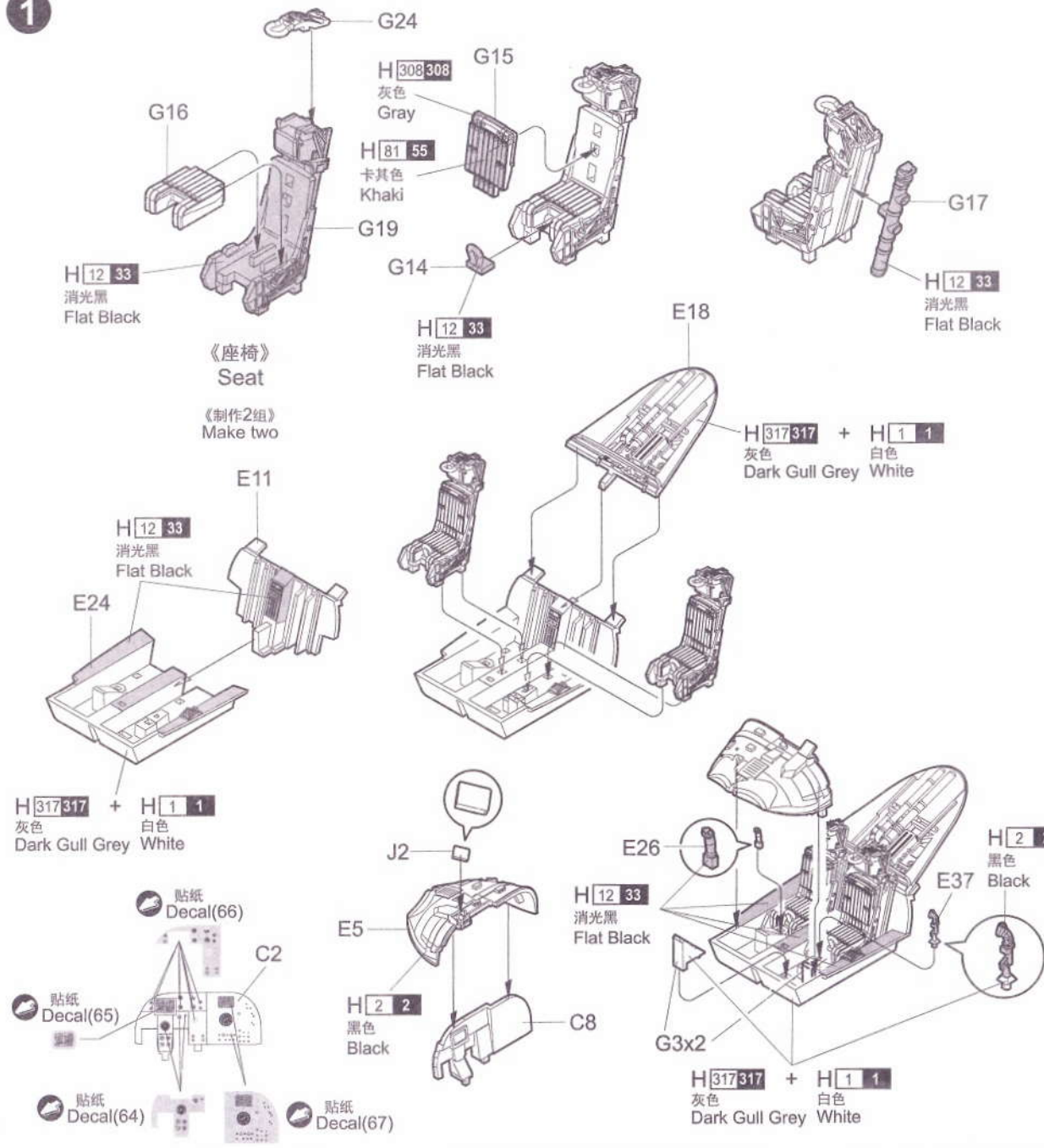

2

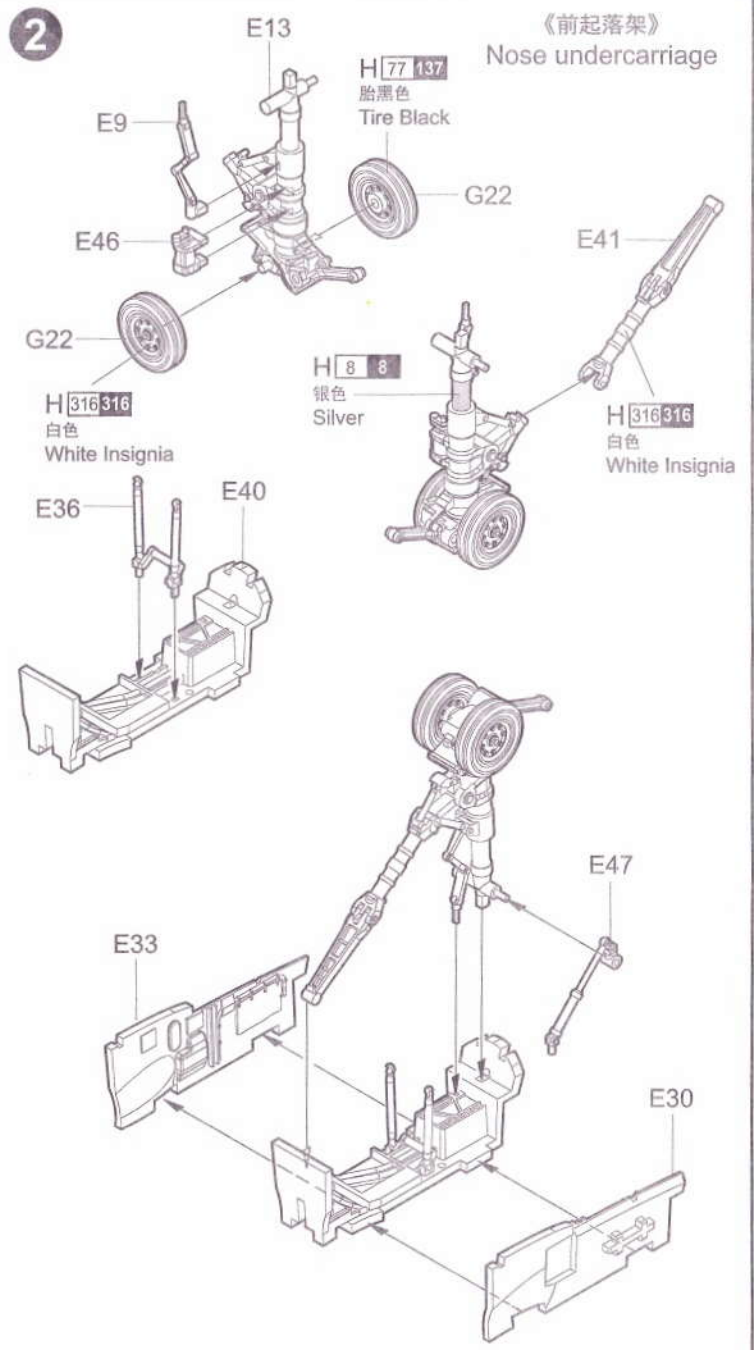

3

《左侧主起落架》
Left main undercarriage

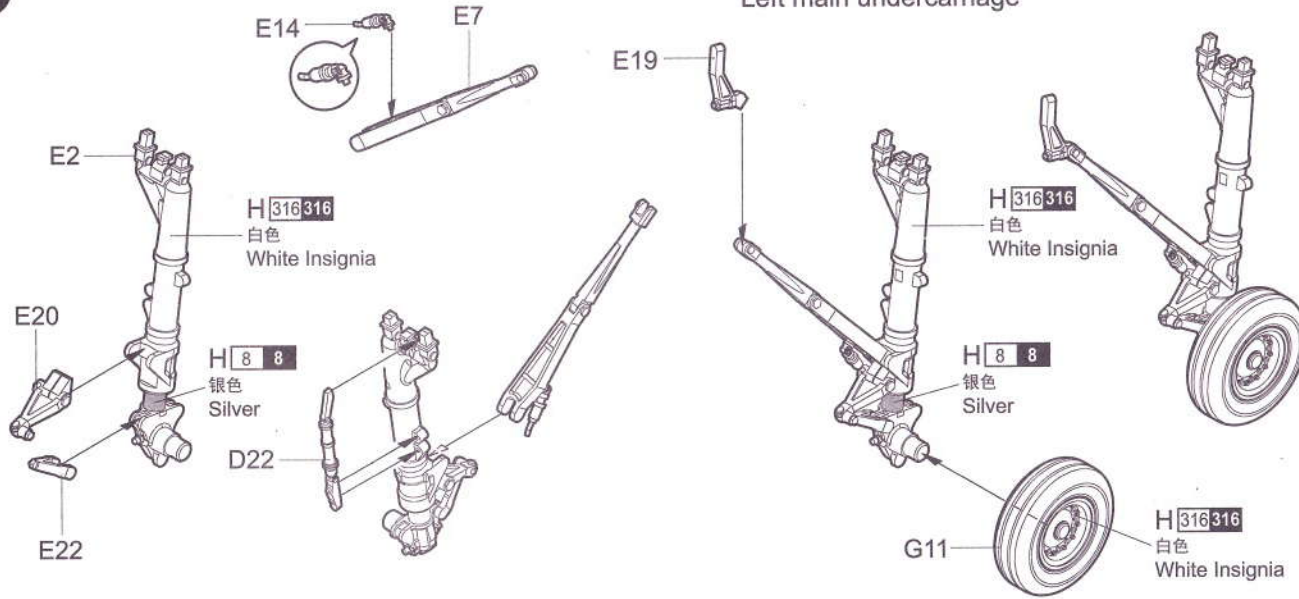

5

《左侧进气道》
Left air intake

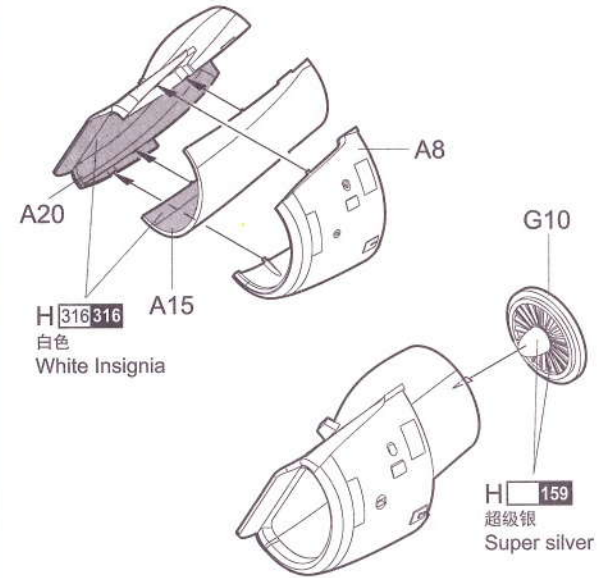

4

《右侧主起落架》
Right main undercarriage

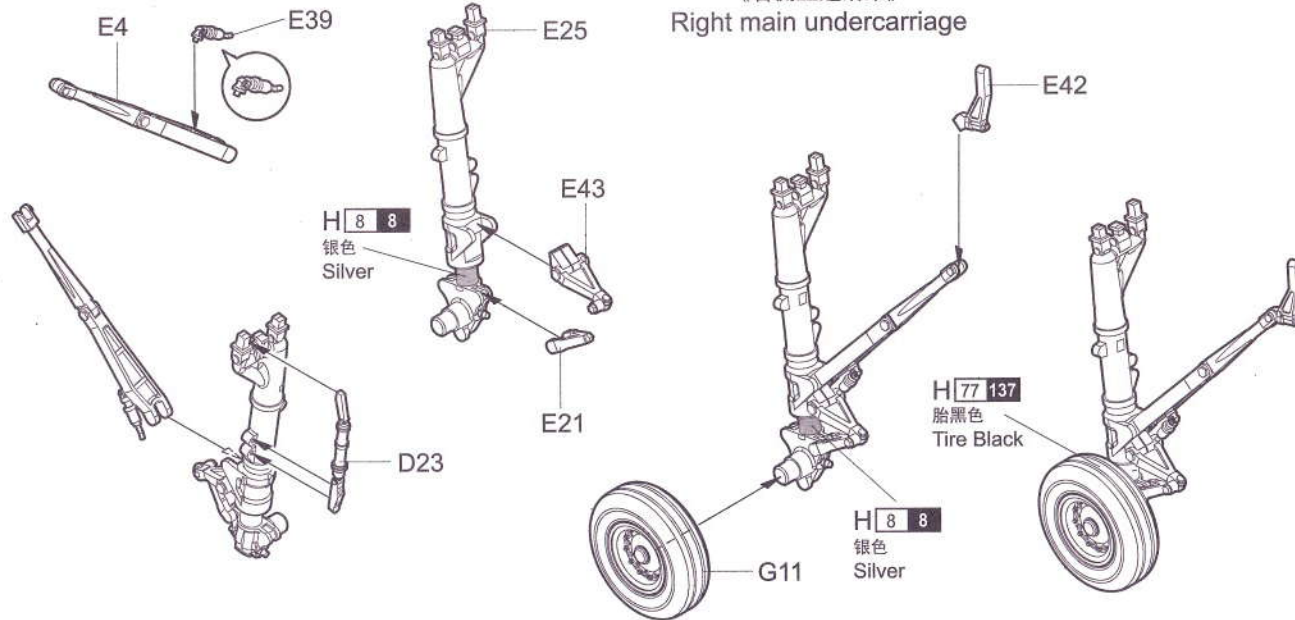

6

《右侧进气道》
Right air intake

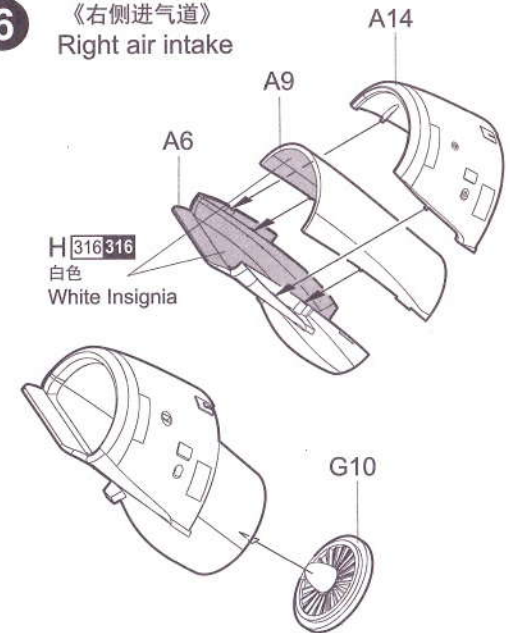

8

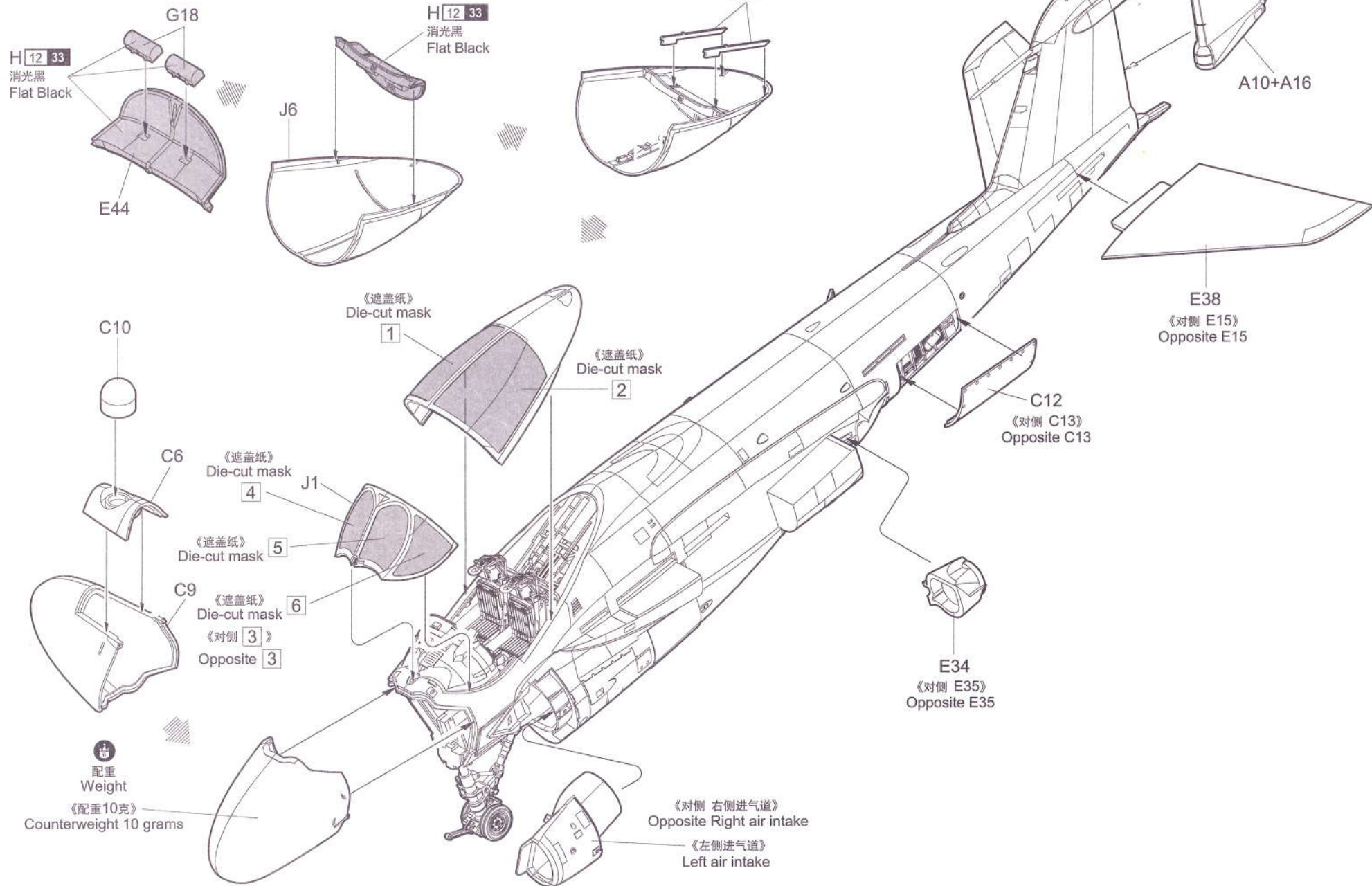

9

《左侧机翼》
Left wing

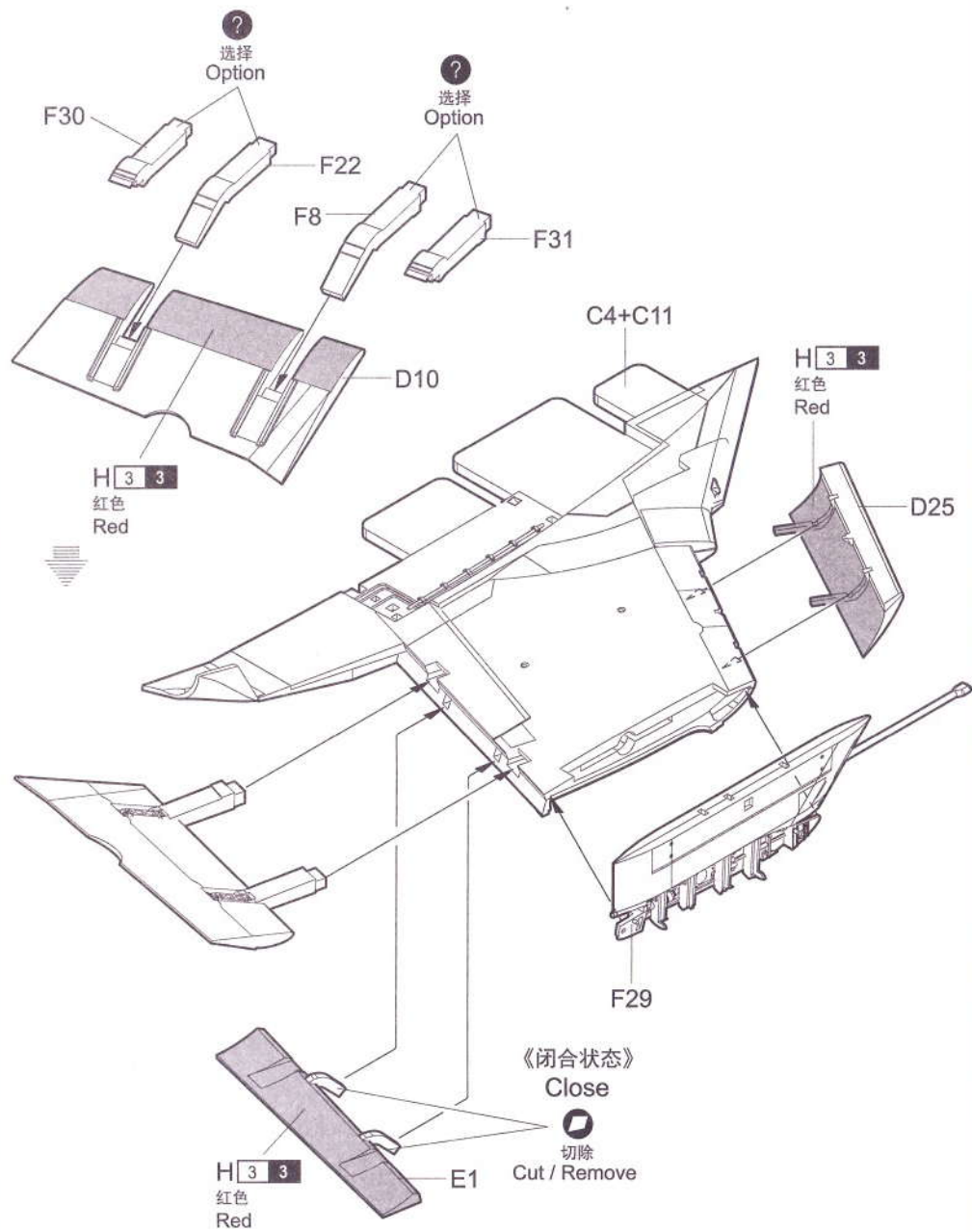

10

《右侧机翼》
Right wing

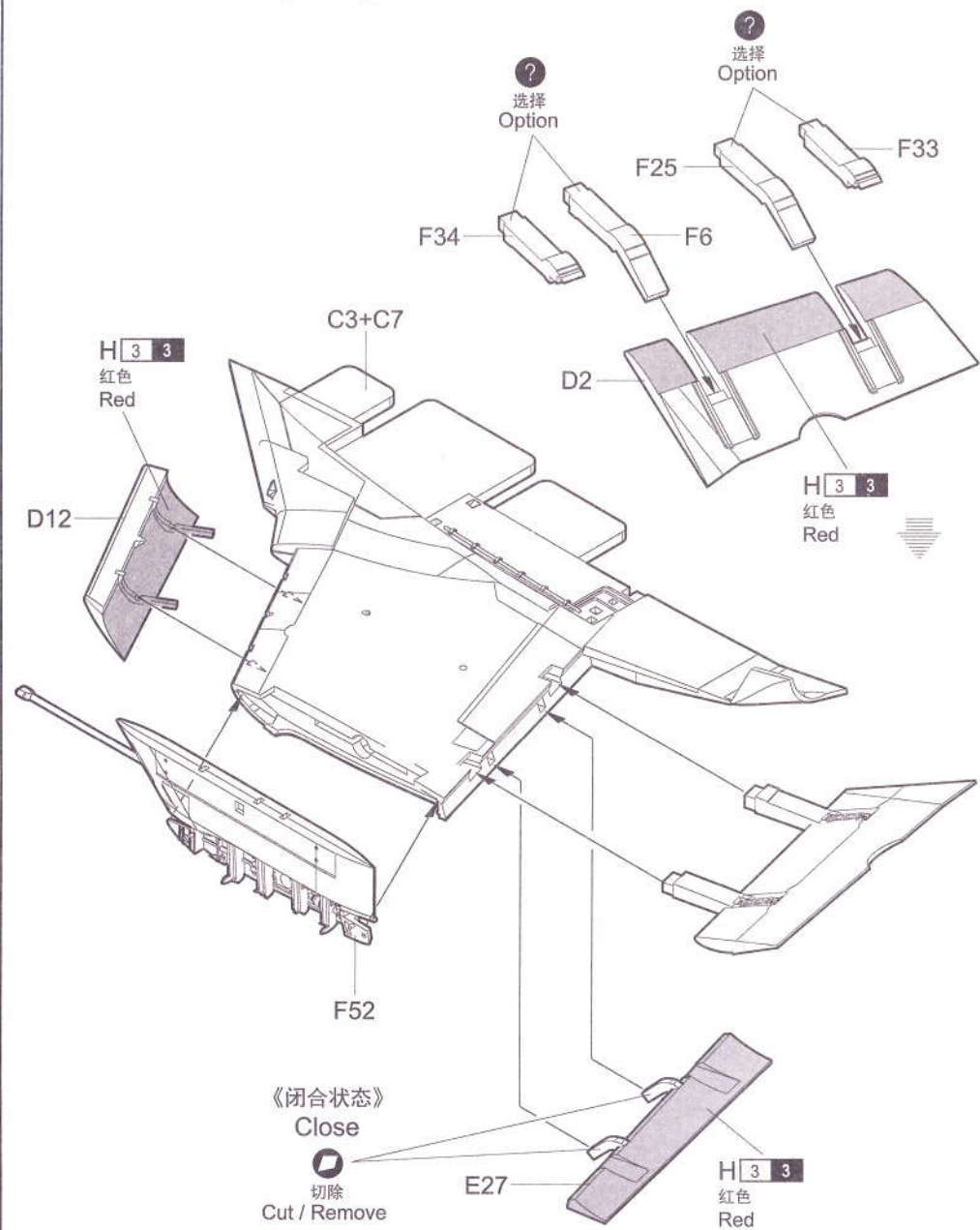

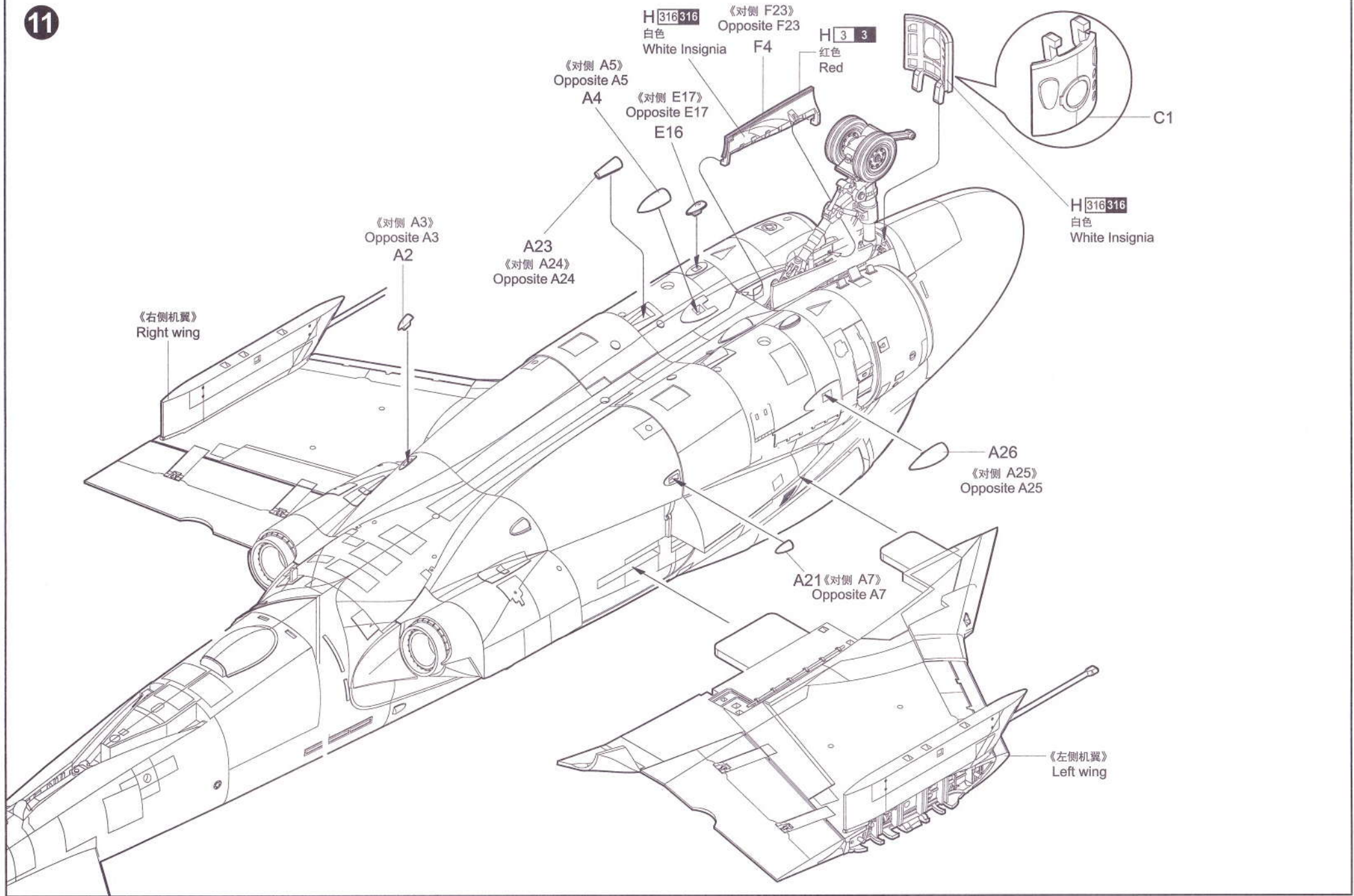

12 《左侧机翼》
Left wing

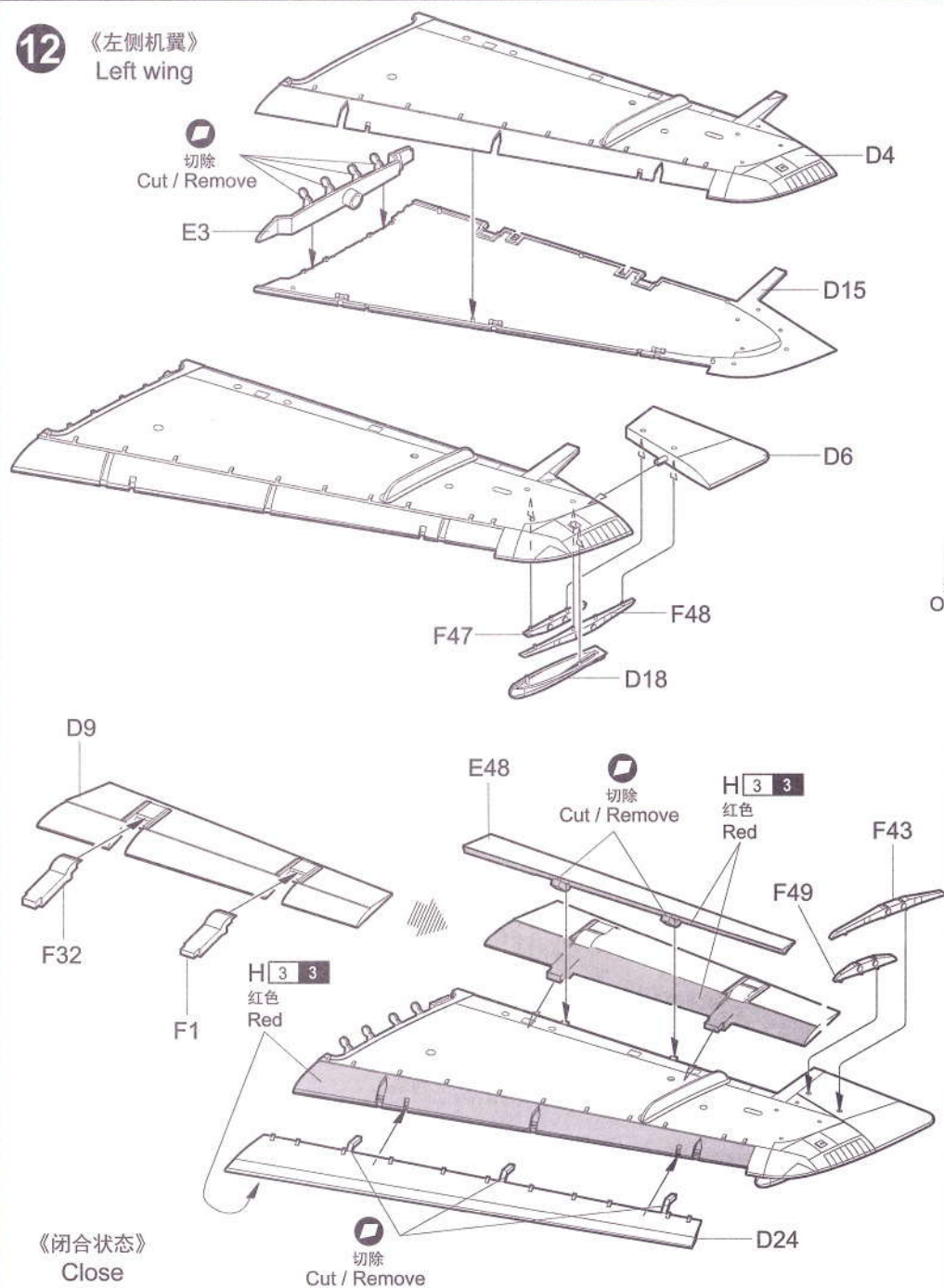

13

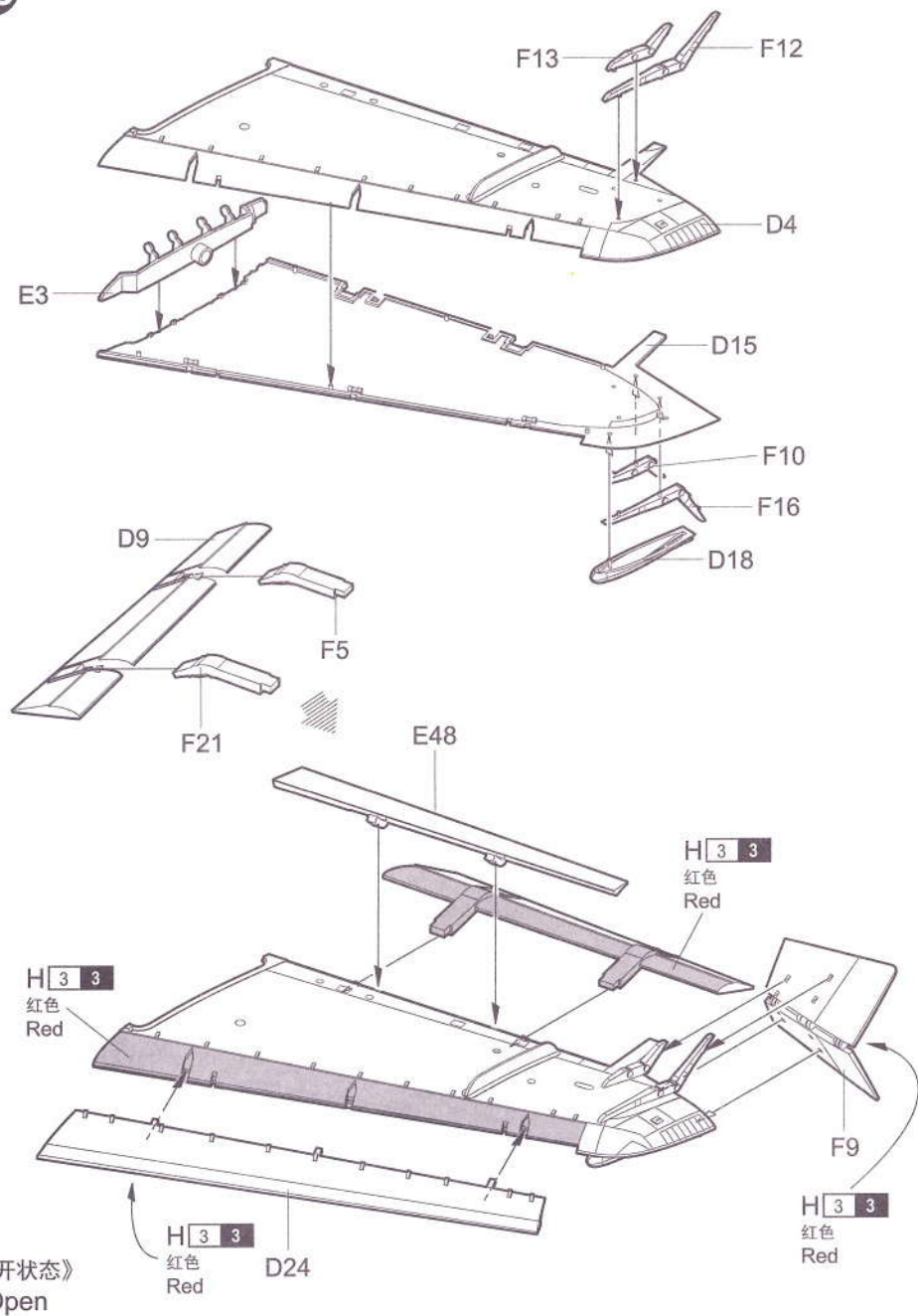

14 《右侧机翼》
Right wing

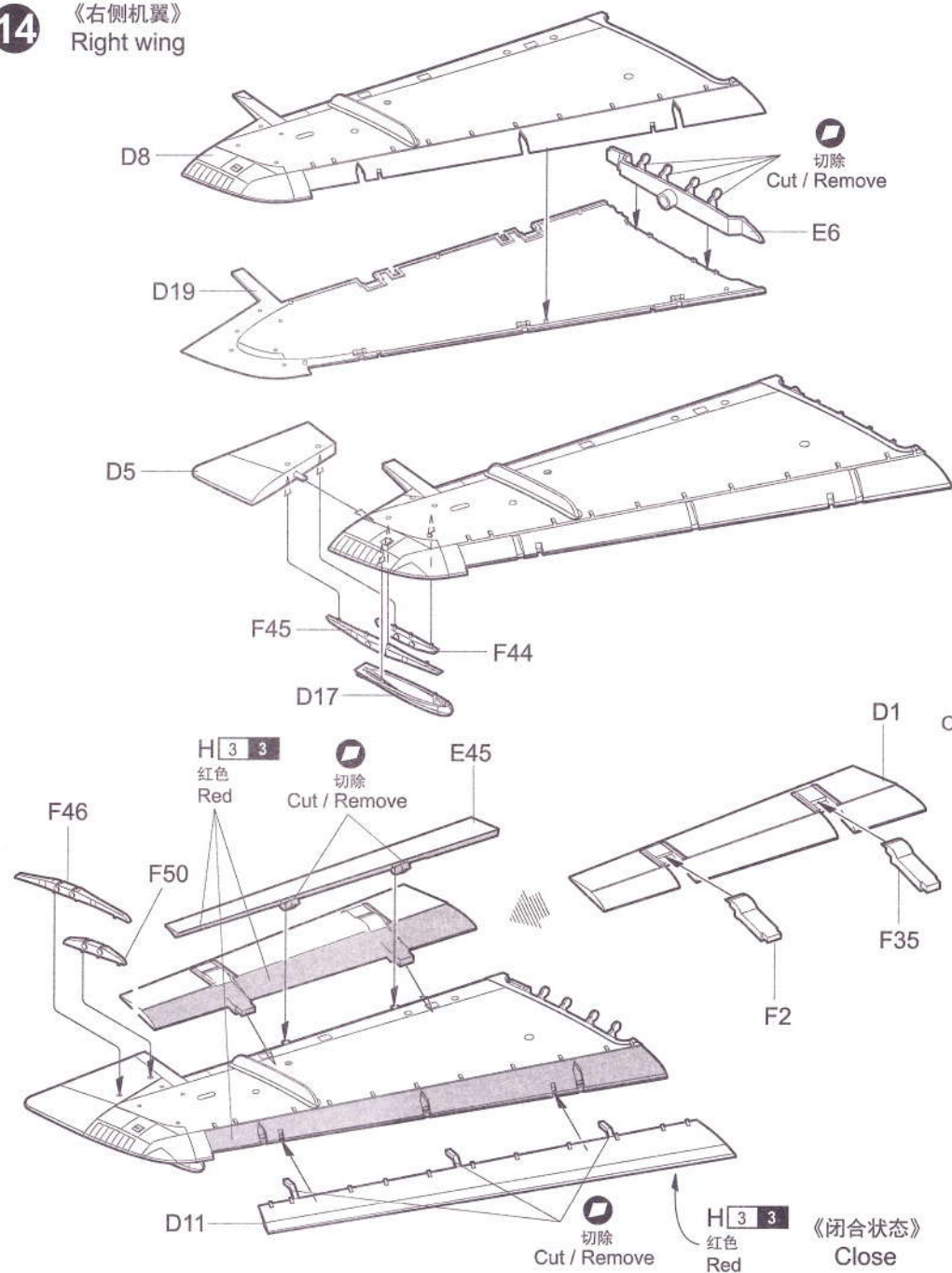

15

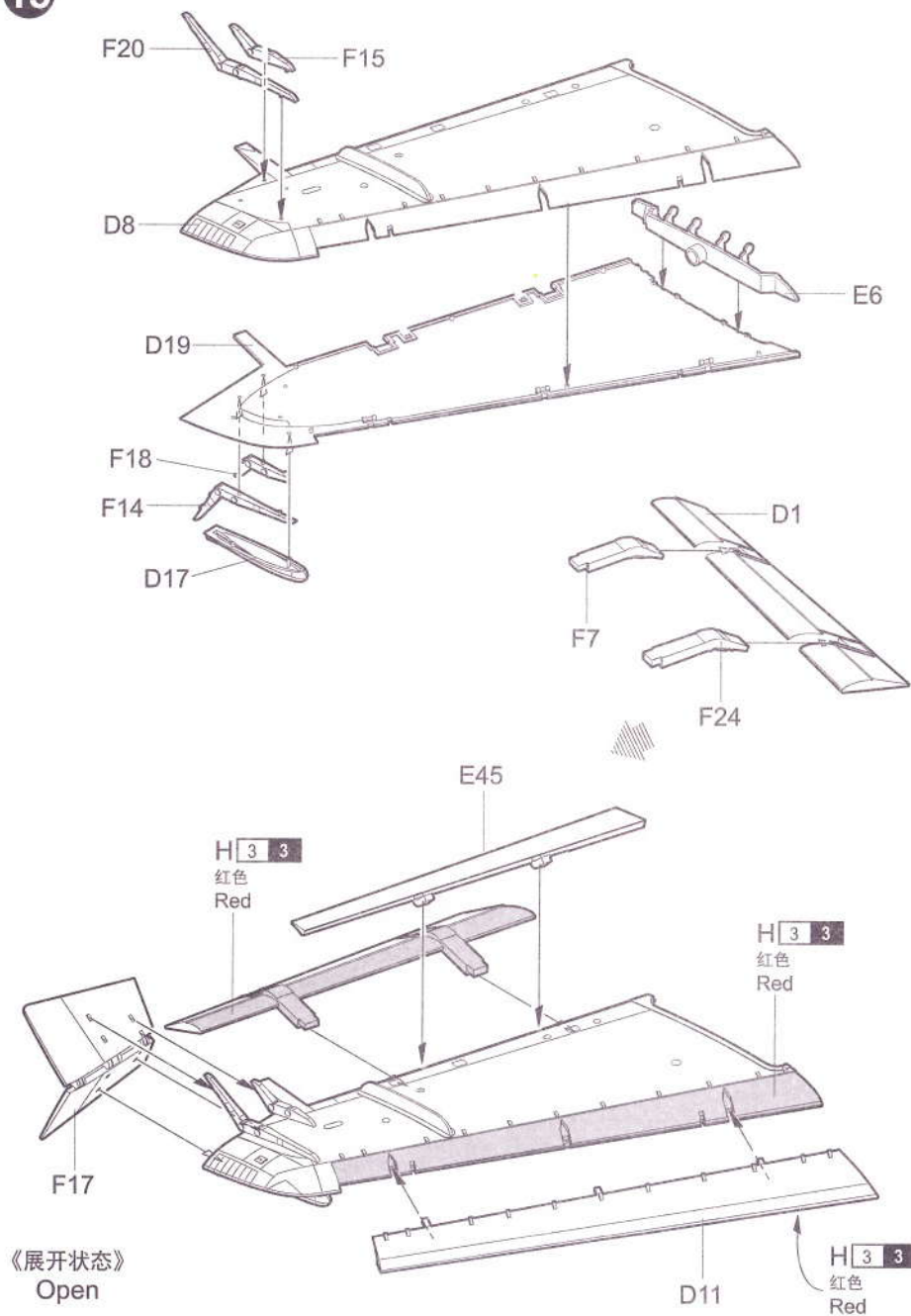

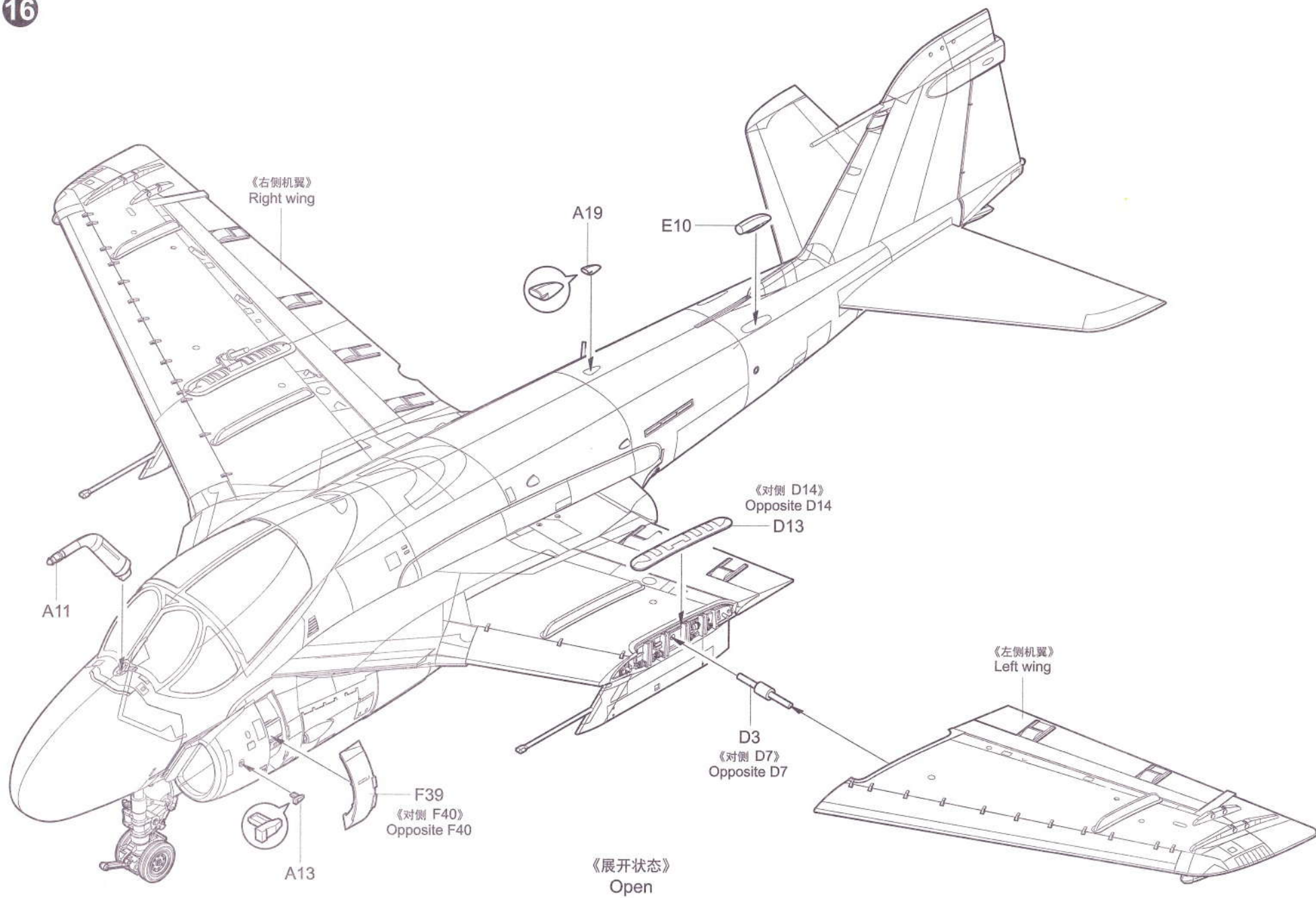

17

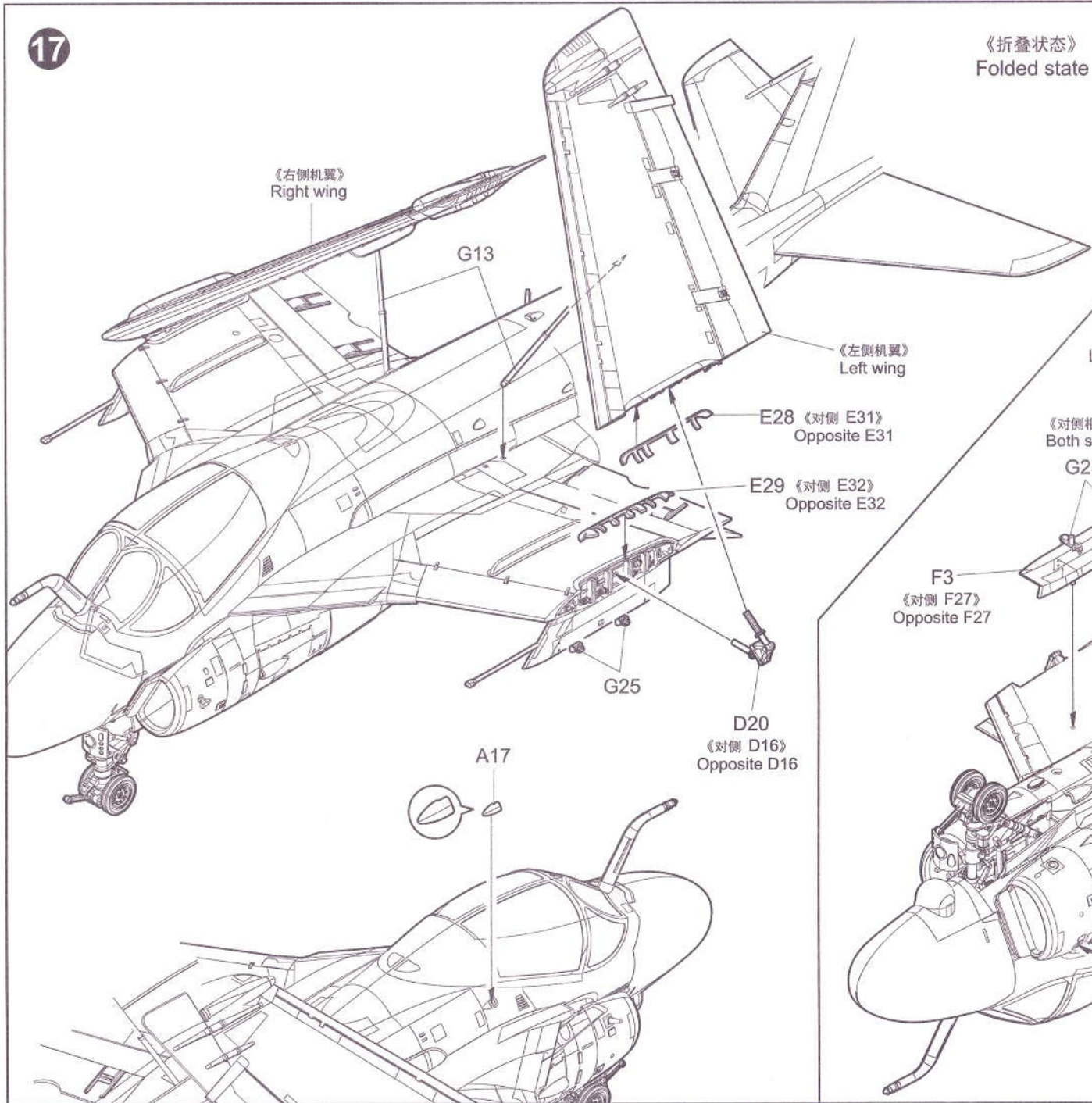
《折叠状态》
Folded state

18

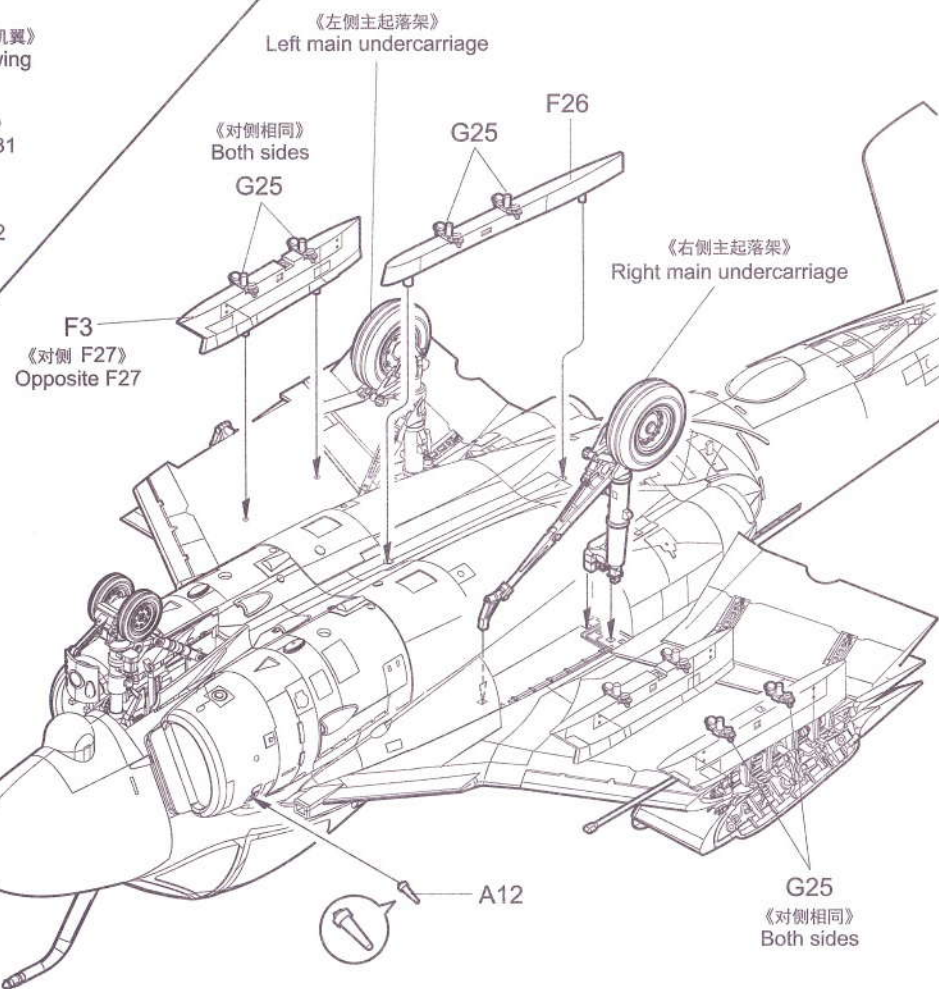

19

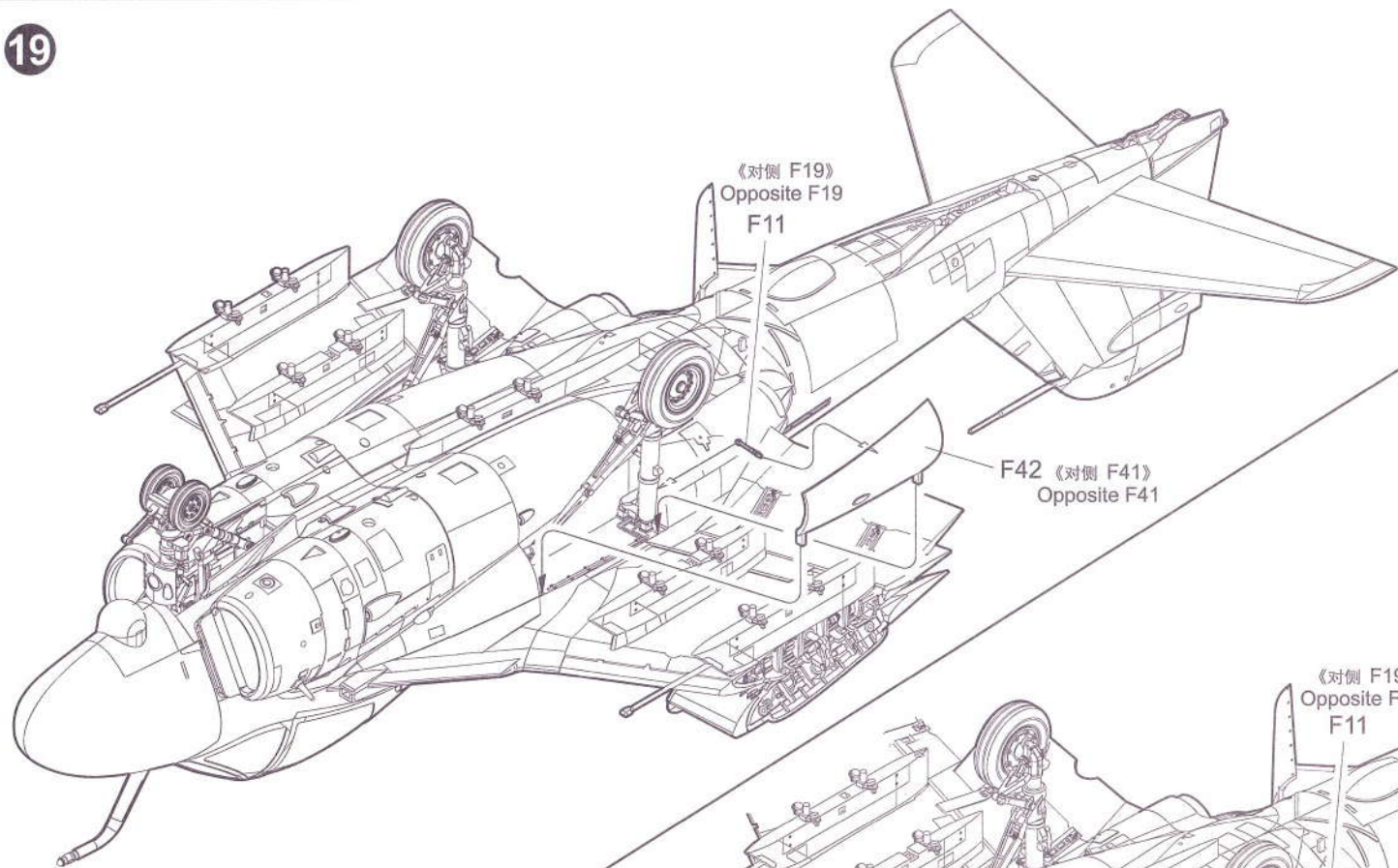

《折叠状态》
Folded state

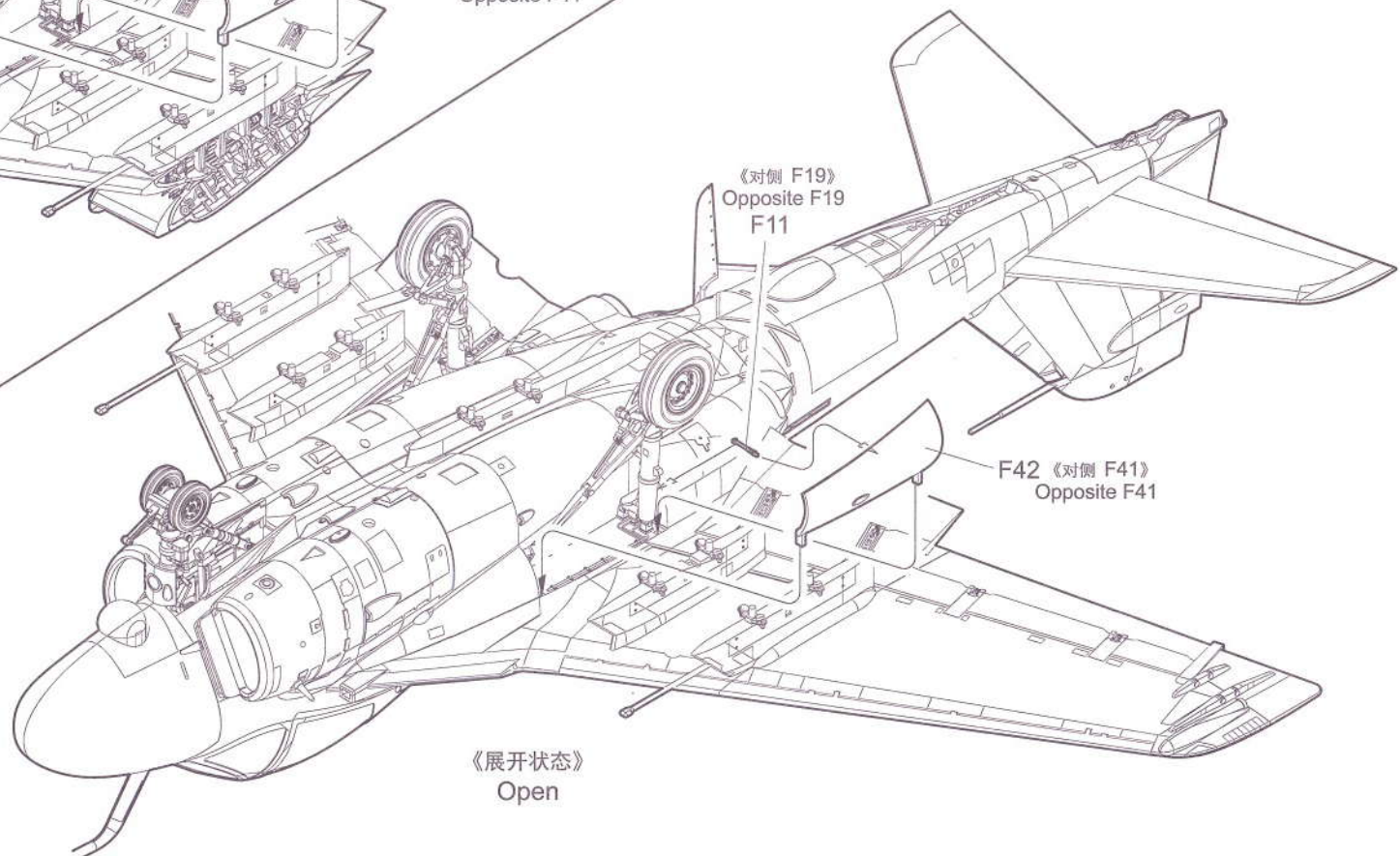

《展开状态》
Open

20

21

《Center line fuel tank》

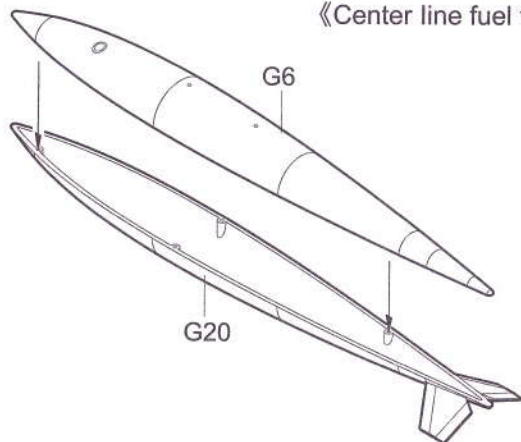

22

《Side fuel tank》

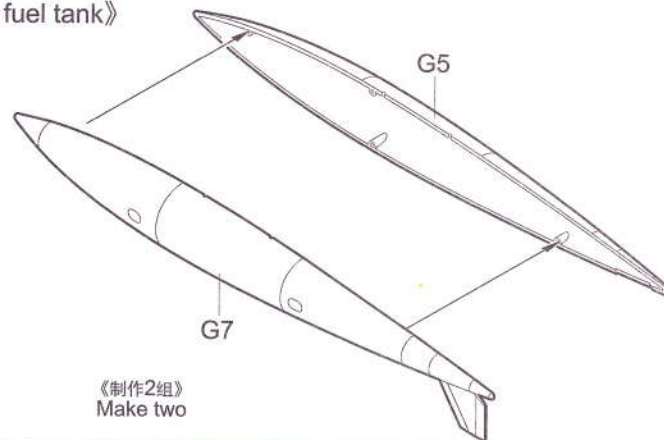

《制作2组》
Make two

23

《MK.20》

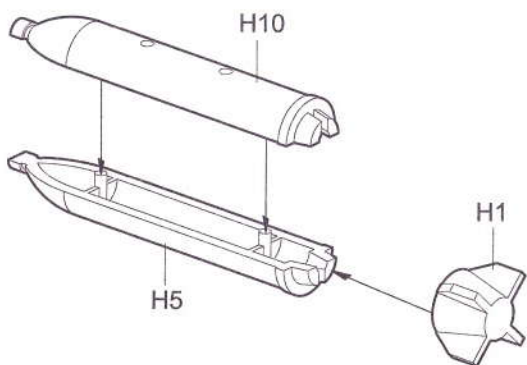

《制作8组》
Make eight

24

《MK.81》

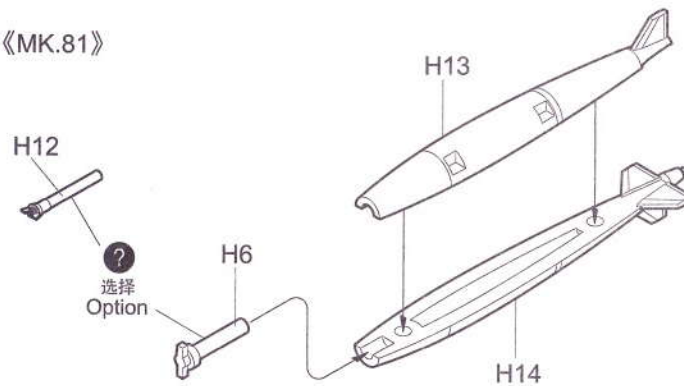

《制作6组》
Make six

25

《M117》

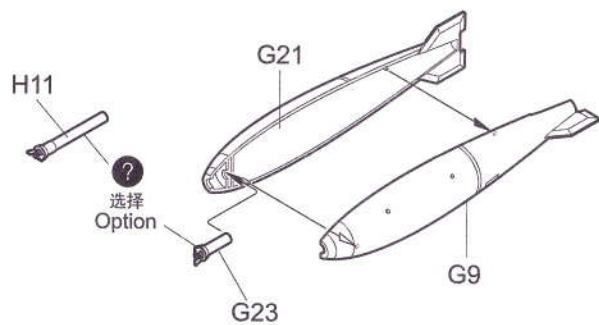

《制作2组》
Make two

26

《GBU-8》

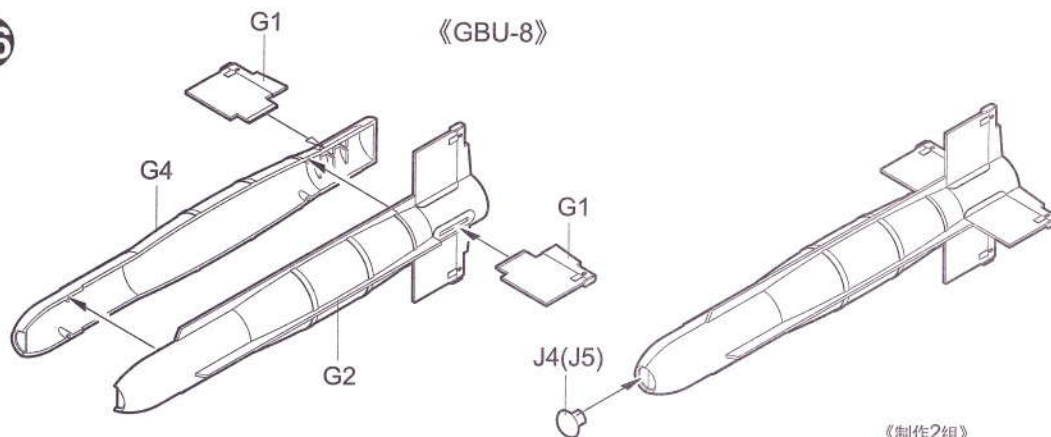

《制作2组》
Make two

28

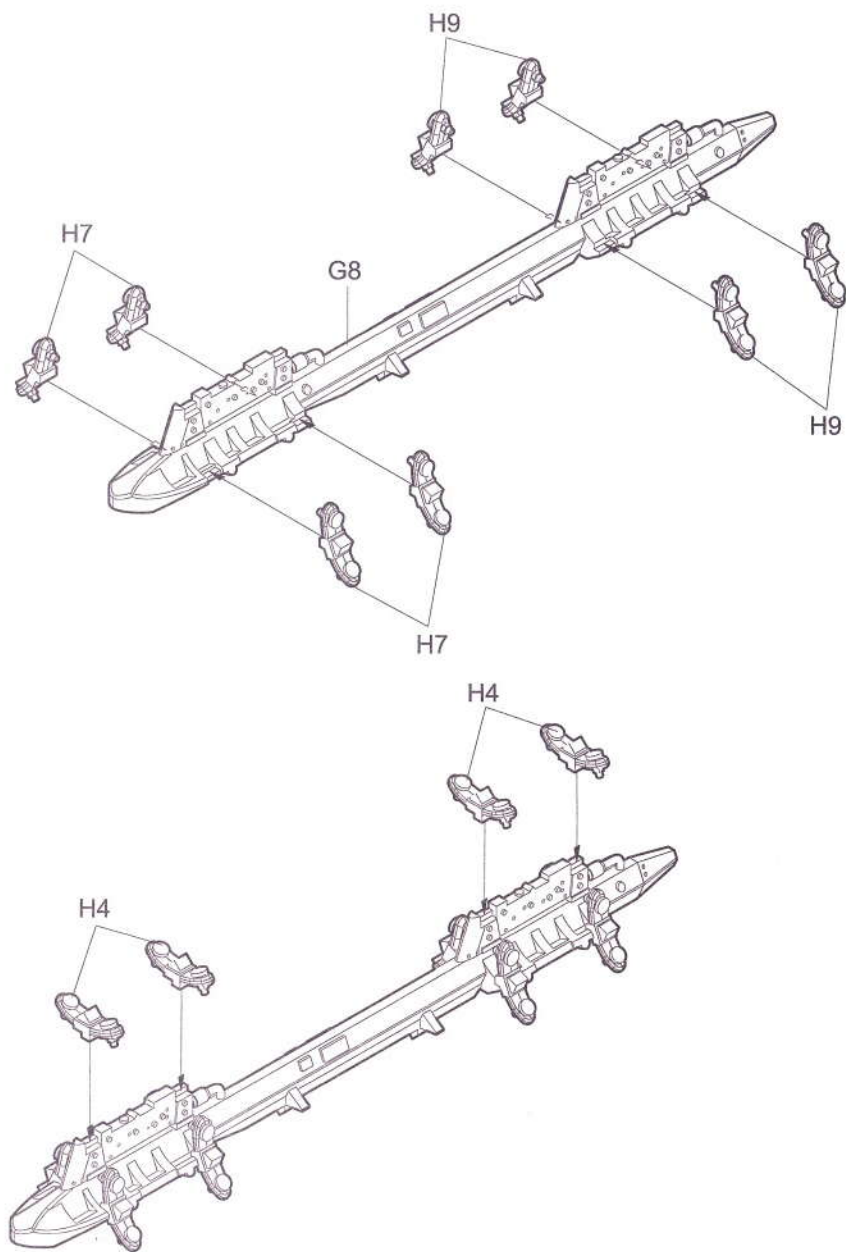

27

《MK.82》

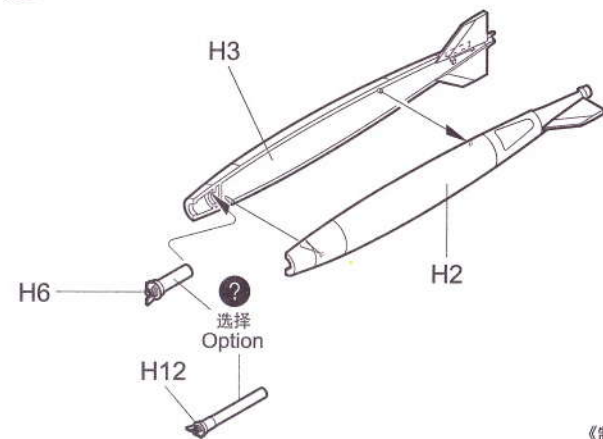

《制作6组》
Make six

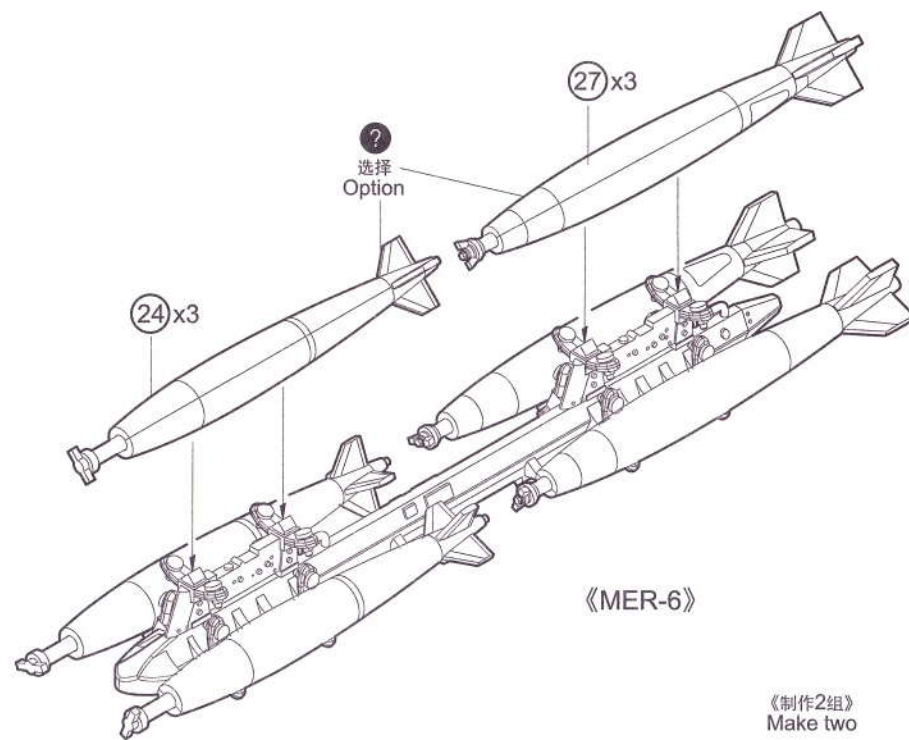

《制作2组》
Make two

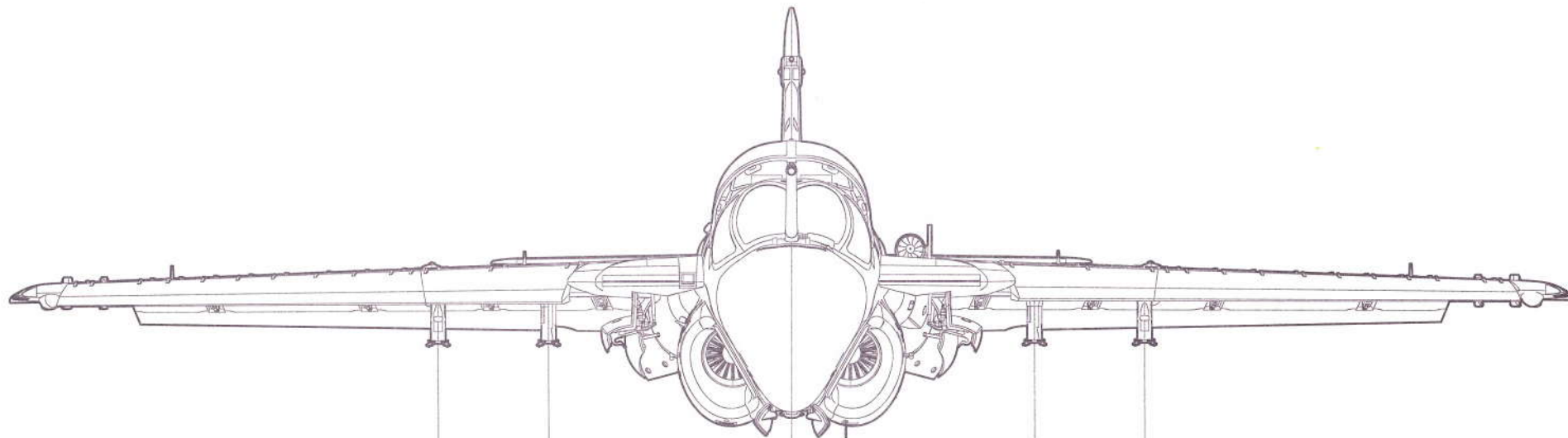

Sta.No.	1	2	3	4	5
Weapon/Tank					
Center line fuel tank			•		
Side fuel tank		•		•	
M117	•	•		•	•
MK.20	•	•		•	•
MK.81	•••	•••	•••	•••	•••
MK.82	•••	•••		•••	•••
GBU-8	•	•		•	•
MER-6	•	•		•	•

涂装同标贴指示 Painting & Marking guide

A USMC, VMA(AW)-522 'Hawks', A-6E/TRAM, 403/ED (BuNo. 161189)

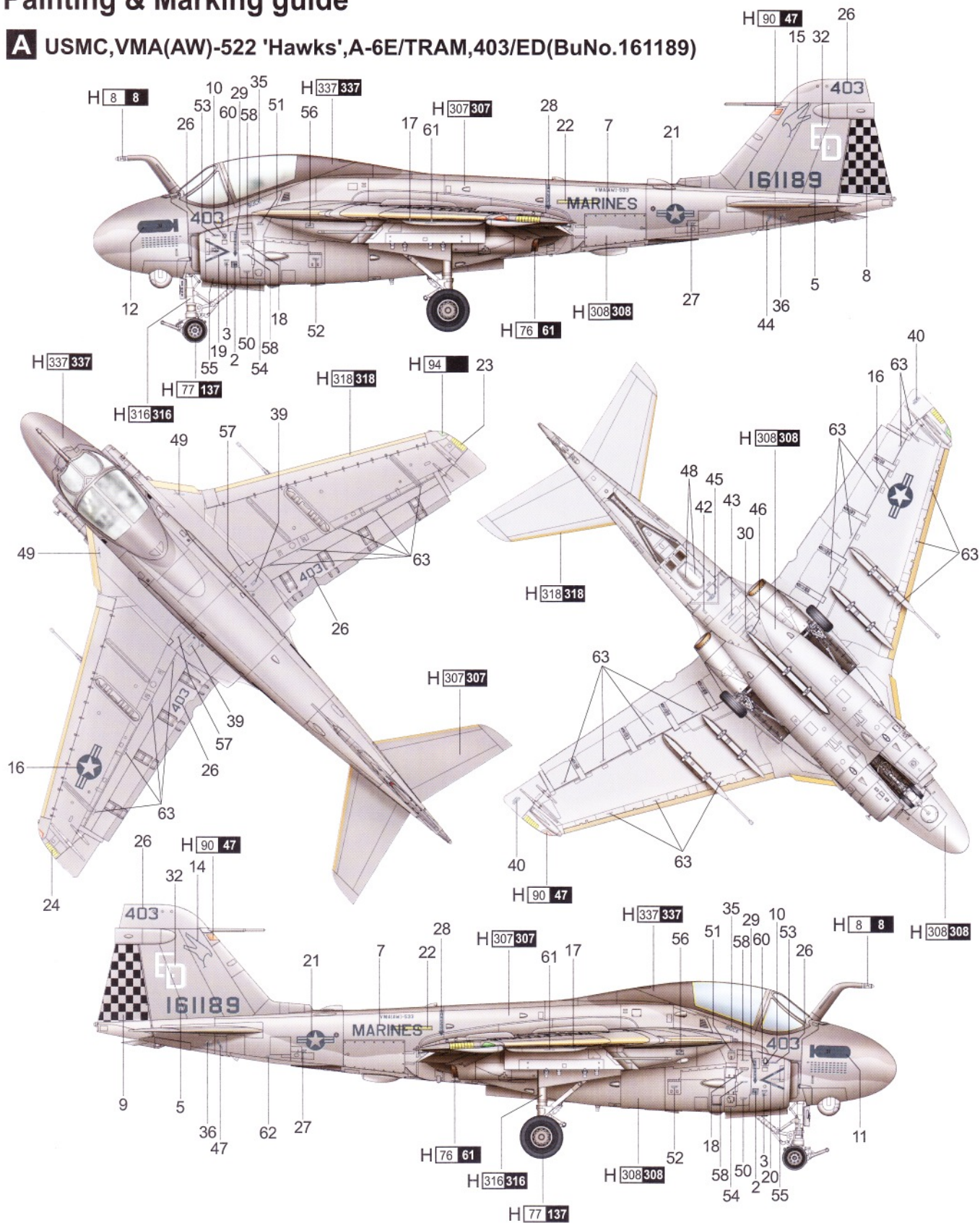

PAINT REFERENCE COLOR

Color	Mr.Hobby	Acrycion	Vallejo	Model Master	Tamiya	Humbrol	Color	Mr.Hobby	Acrycion	Vallejo	Model Master	Tamiya	Humbrol
Dark Compass Ghost Grey 灰色	H 307 307	N 307	—	1741	XF22	128	Burnt Iron 烧铁色	H 76 61	N 76	863	1795	X10	53
Gray Blue 浅灰兰	H 337 337	N 337	—	1721	XF20	145	Silver 银色	H 8 8	N 8	997	1546	X11	11
Gray 灰色	H 308 308	N 308	990	1728	XF19	127	Black 黑色	H 2 2	N 2	861	1747	X1	21

H☒ AQUEOUS HOBBY COLOR ☒ Mr. COLOR N☒ ACRYCION COLOR

涂装同标贴指示 Painting & Marking guide

B US Navy, VA-196 'Main Battery', A-6E/TRAM, 500/NK (BuNo. 159579)

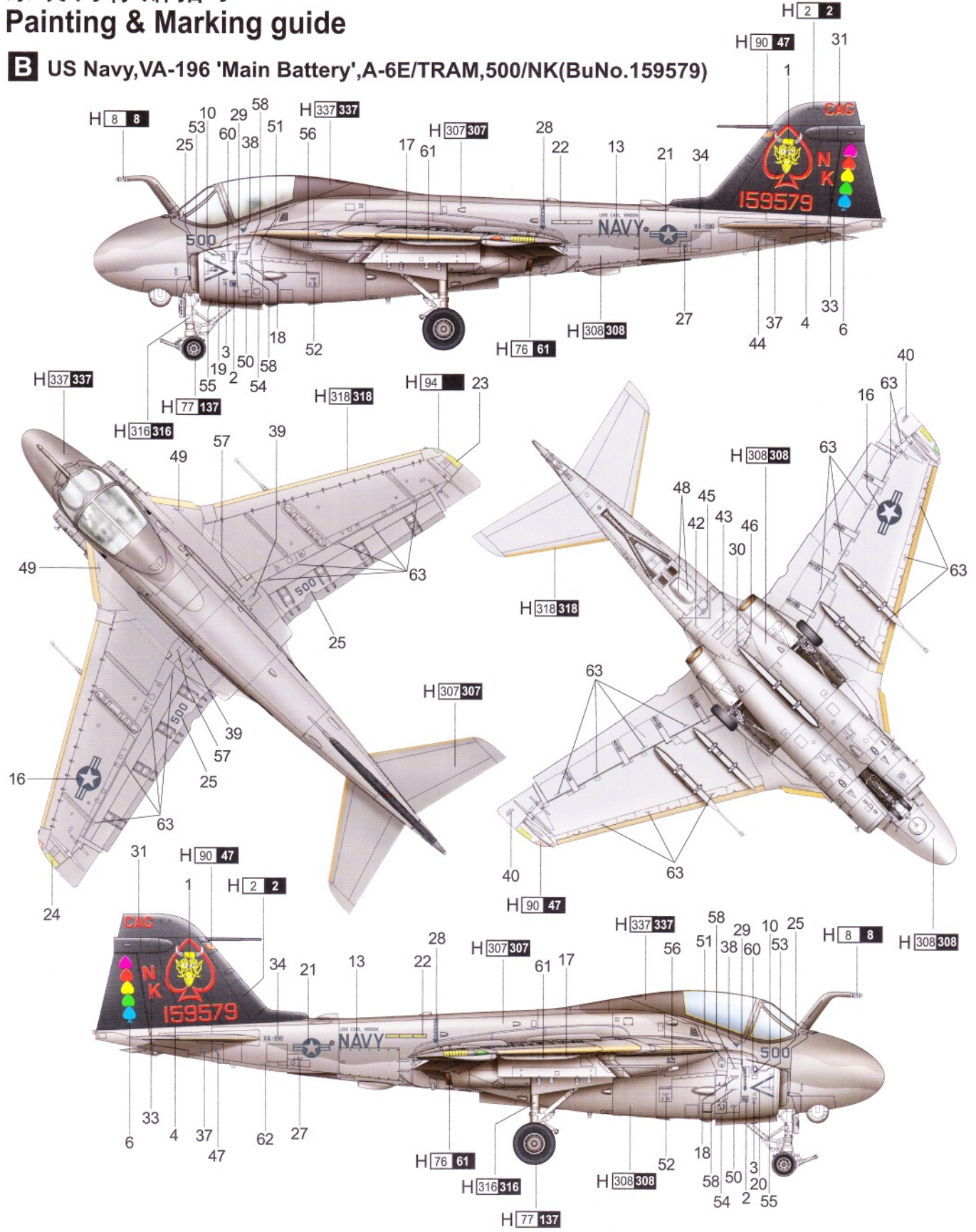

PAINT REFERENCE COLOR

Color	Mr.Hobby	Acrycion	Vallejo	Model Master	Tamiya	Humbrol	Color	Mr.Hobby	Acrycion	Vallejo	Model Master	Tamiya	Humbrol
Tire Black 胎黑色	H 77 137	N 77	-	-	XF85	-	Clear Red 透明红	H 90 47	N 90	934	-	X27	-
White Insignia 白色	H 316 316	N 316	991	1745	X2	22	Clear Green 透明绿	H 94	N 94	936	-	X25	-
Radome 整流罩色	H 318 318	N 318	917	1709	-	148							

H AQUEOUS HOBBY COLOR Mr. COLOR N ACRYSION COLOR

涂装同标贴指示 Painting & Marking guide

MK.20 x8

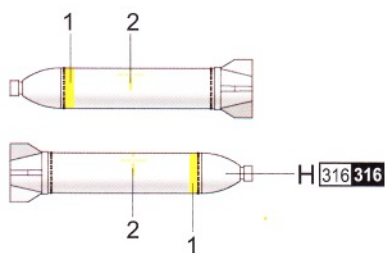

MK.81 x6

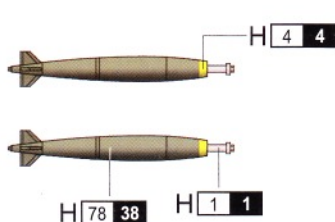

MK.82 x6

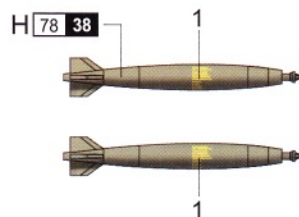

M117 x2

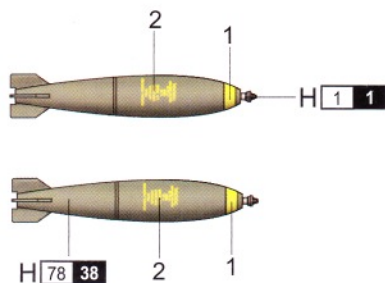

Center line fuel tank

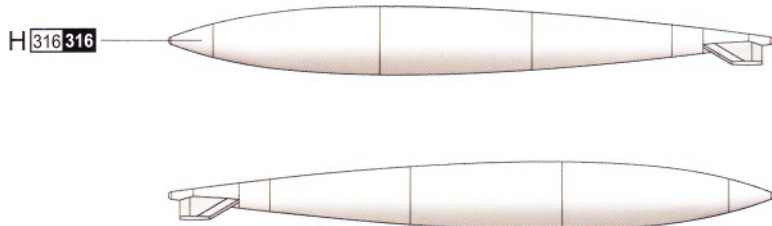

GBU-8 x2

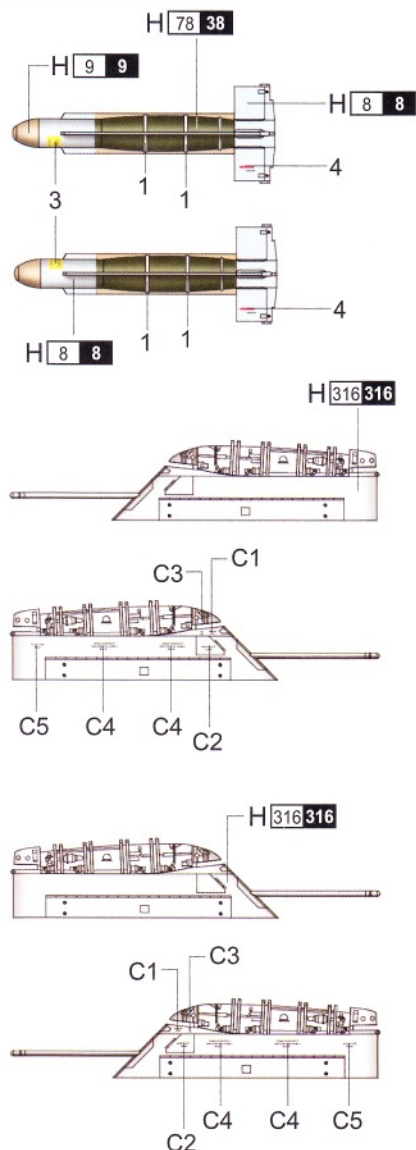

Side fuel tank x2

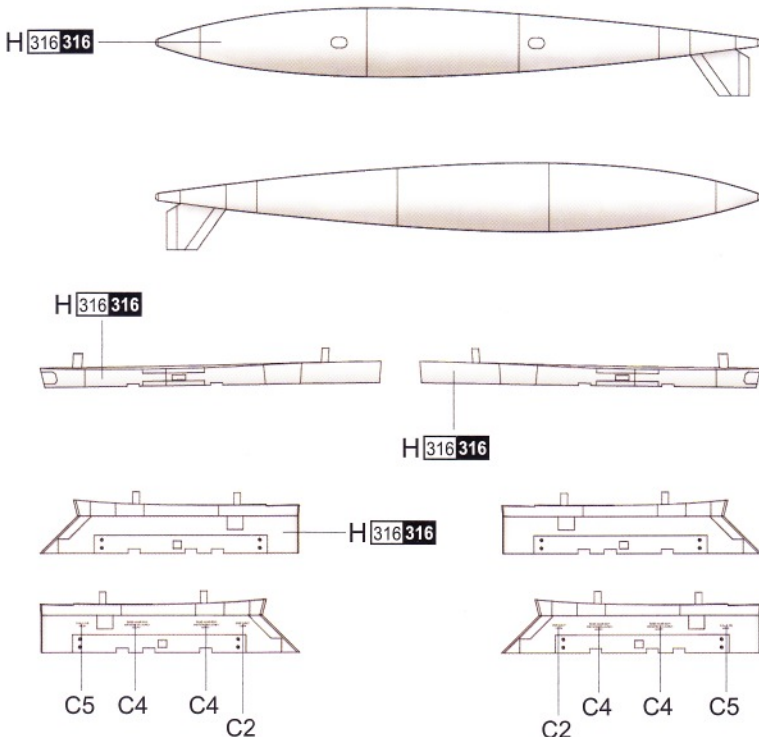

PAINT REFERENCE COLOR

Color	Mr.Hobby	Acrycion	Vallejo	Model Master	Tamiya	Humbrol
Silver 银色	H 8 8	N 8	997	1546	X11	11
White Insignia 白色	H 316 316	N 316	991	1745	X2	22
Olive Drab(2) 橄榄(2)	H 78 38	N 78	950	-	-	-
Gold 金色	H 9 9	N 9	878	1744	X12	16
White 白色	H 1 1	N 1	842	1745	X2	22
Yellow 黄色	H 4 4	N 4	953	1514	X8	69

H AQUEOUS HOBBY COLOR X Mr. COLOR N ACRYCION COLOR



159579 161189



V MAIAWJ-533
MARINES

159579 161189



7
V MAIAWJ-533
MARINES

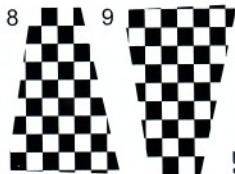

USS CARL VINSON
NAVY



500 500 500 25 500



403 403 403 403 403 26 403

CAG CAG



N 33 N
K K

VA-196 "BUCK" A-6E (BIBES) A-6E (DDOFS) V SAFETY ACCESS SAFETY ACCESS SAFETY ACCESS
VA-196 "BUCK" A-6E (BIBES) A-6E (DDOFS) V SAFETY ACCESS SAFETY ACCESS SAFETY ACCESS

42 45 NO STEP NO STEP NO STEP NO STEP NO STEP NO STEP
43 46 NO STEP NO STEP NO STEP NO STEP NO STEP NO STEP
44 47 NO STEP NO STEP NO STEP NO STEP NO STEP NO STEP

DO NOT PAINT 48 KALKRAY 49 50 51 52 53 54 55 56 57 58 59 60 61 62 NO STEP NO STEP NO STEP NO STEP NO STEP NO STEP 63

Center line fuel tank

Side fuel tank x2

MK.82 x6



MK.20 x8

GBU-8 x2

M117 x2

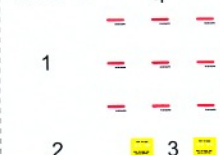
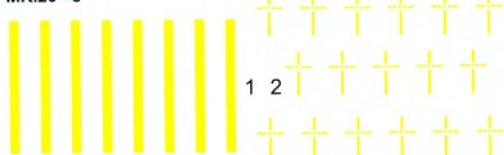

C1 C2 C3 C4 C5

01642 1/72 A-6E TRAM Intruder