

USS Arleigh Burke DDG-51

美国海军DDG-51阿利·伯克号导弹驱逐舰



READ BEFORE ASSEMBLY:

- Study and understand these instructions thoroughly before beginning assembly
- When needed, remove photo-etch parts carefully using a modeling knife or photo etch sprue cutter, being careful not to damage or lose small parts.
- Take extra care in handling photo etch parts in order to avoid injury
- Apply instant cement sparingly to photo etch parts where instructed
- Tools recommended(not included in kit):Plastic and instant cements,sprue cutters,long nose pliers,,modeling knife, small files, tweezers, pin vise & scissors. Soft cloth and sandpaper will also assist in construction
- Glue and paint are not included in the kit. Use plastic cement and hobby paints only. Color guide for purchasing paint is included in the kit.

装配之前仔细阅读

- 小心用模型锉刀锉平所有零件表面的注射浇口。
- 小心用刀片切下蚀刻片零件，不要遗失小零件。
- 用强力快干胶水粘合蚀刻片零件和金属轴。过量的快干胶水使用可能导致可动零件会粘住，小心涂胶。
- 取蚀刻片时应特别注意安全，防止利边划伤手指。
- 某些零件表面需贴水上贴纸，请选择在装配的同时进行。
- 推荐模型工具(自备)：胶水，水口剪刀，长咀钳，刀片，锉刀，镊子，钳，钻，剪刀，瞬间快干胶。
- 软布同砂纸同时也应该是必备工具。
- 请使用塑料胶水和油漆，模型内不含。



贴纸
Decal



锉平
File / Sand



选择
Option



不涂胶水
No cement



弯曲
Bend



使用强力胶
Cyanoacrylate glue



配重
Weight



钻孔
Make hole



切除
Cut / Remove

水贴纸的使用:

1. 从水贴纸上剪下印花;
2. 将印花放入温水中浸10秒, 然后放在干净布上。
3. 拿着印花纸板将印花移到模型上;
4. 手指蘸水将印花移到适当的位置;
5. 用软布轻压印花直至水干, 气泡消失。

DECAL APPLICATION

1. Cut off decal from sheet.
2. Dip the decal in tepid water 40°C for about 10 sec. and place on a clean cloth.
3. Hold the backing sheet edge and slide decal onto the model.
4. Move decal into position by wetting decal with finger.
5. Press decal gently down with a soft cloth until excess water and air bubbles are gone.
6. Allow decal to dry completely before handling model.

上船体
Upper hull

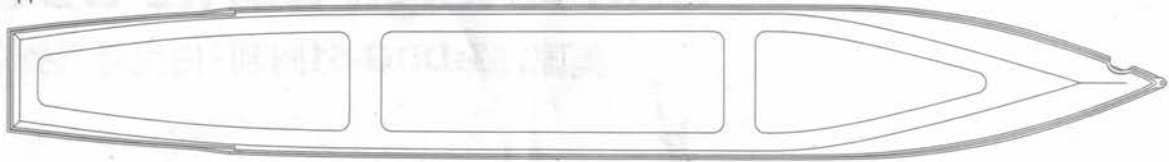

下船底
Lower hull

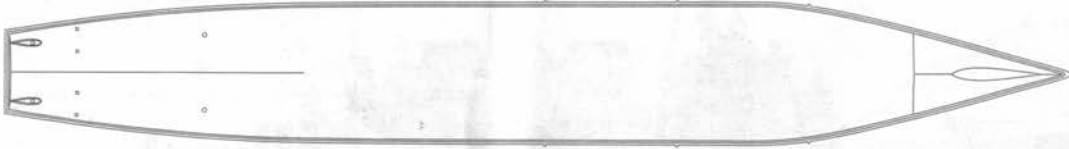

水线板
Waterline plate

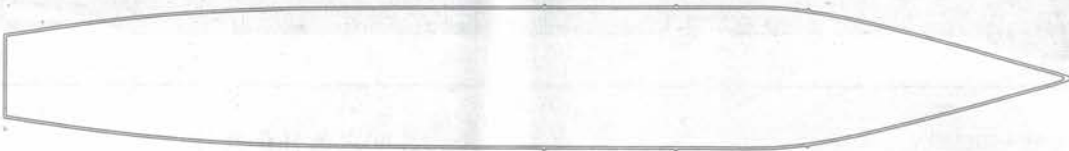

甲板
Deck

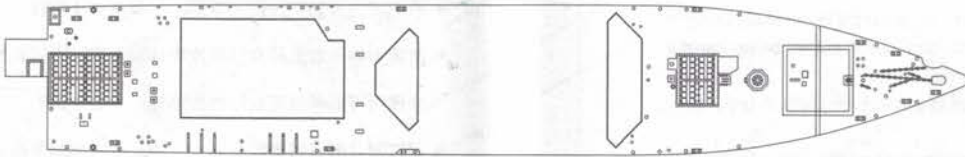

A

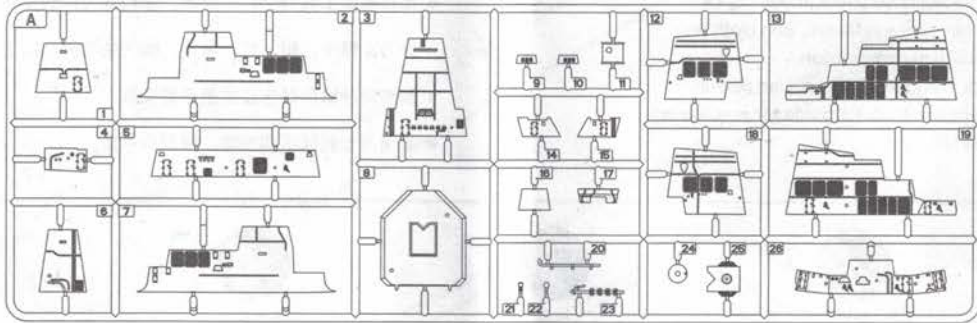

1/650 USS ARLEIGH BURKE CLASS DESTROYER
DDG-51 ARLEIGH BURKE

B

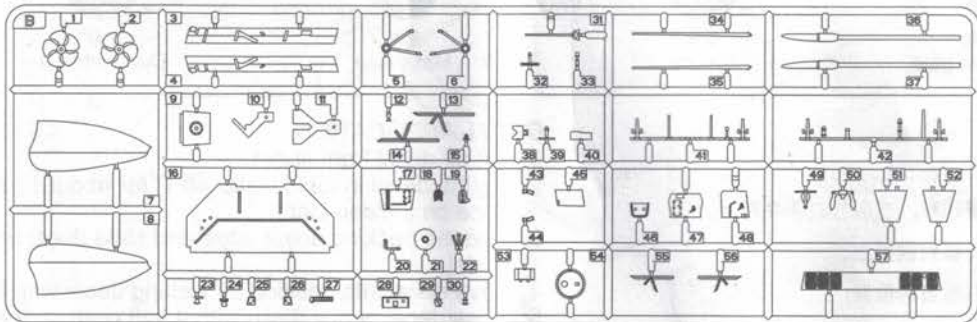

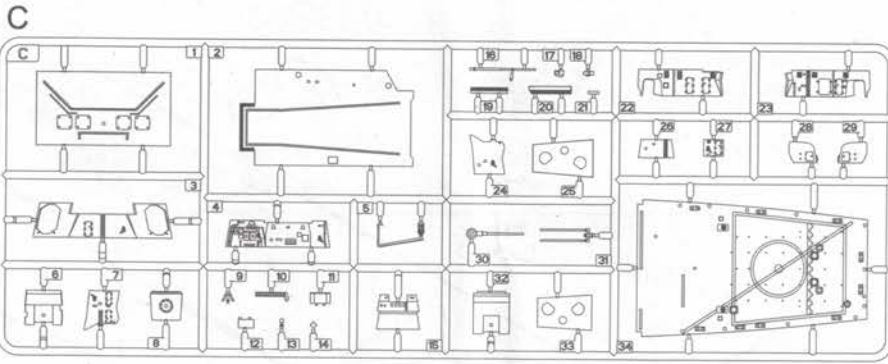

Dx2

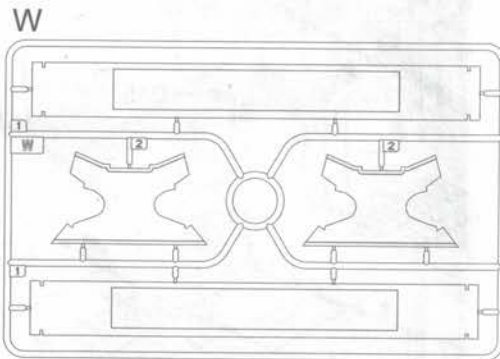
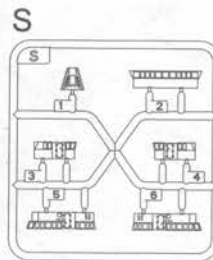
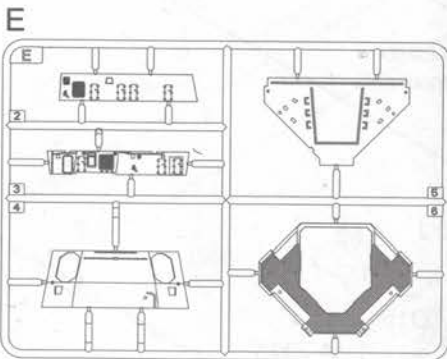
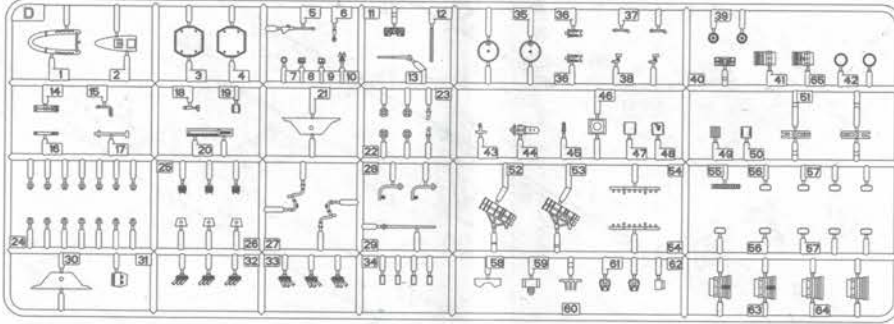

<<蚀刻片>>
Photo Etched

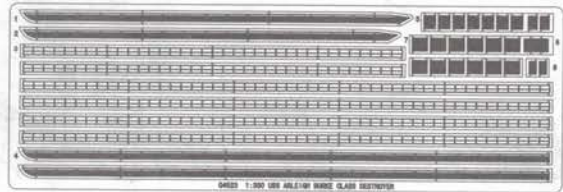

<<贴纸>>
Decal

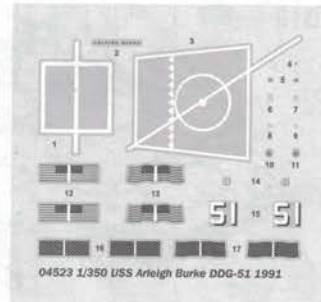

1

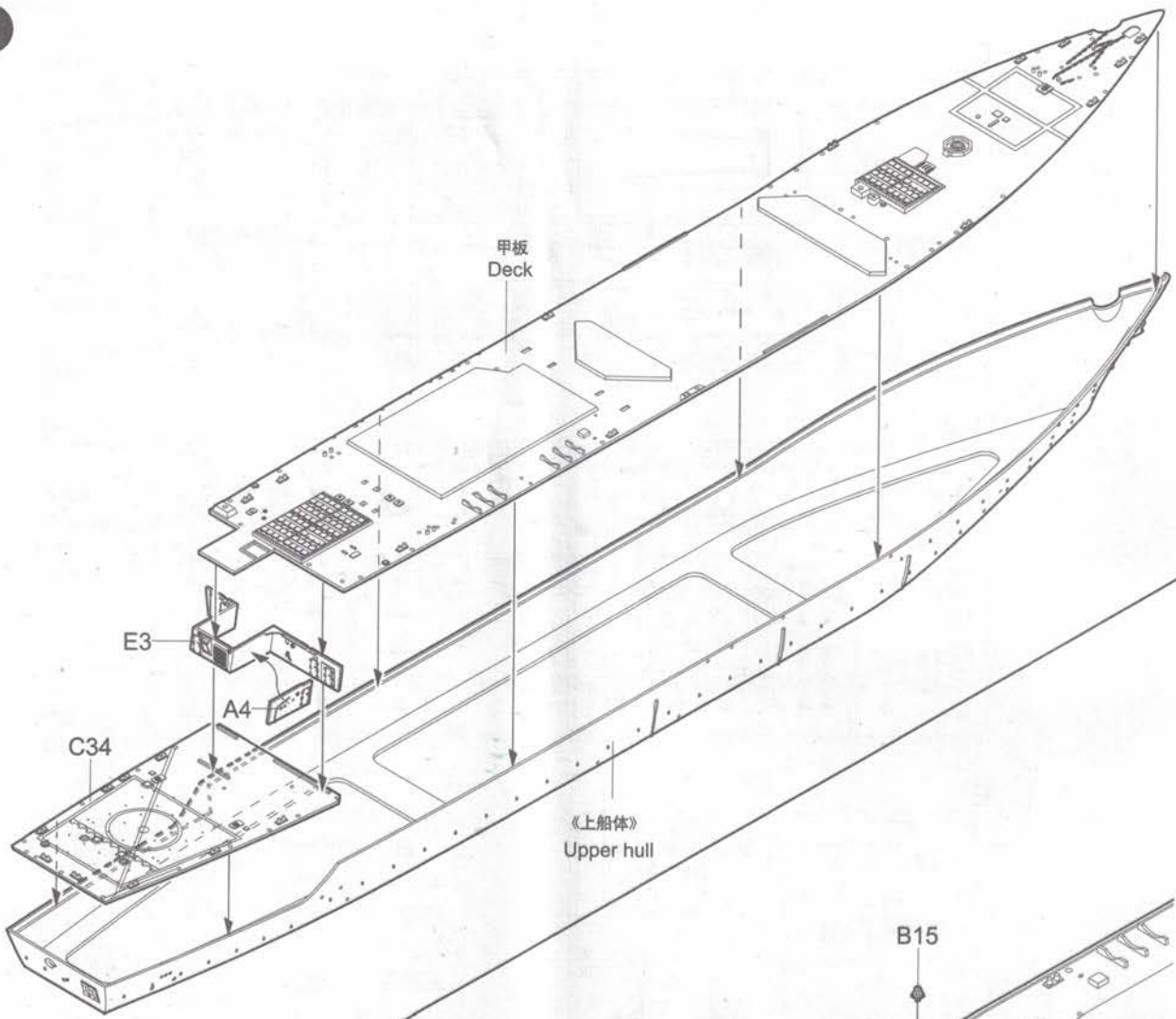

2

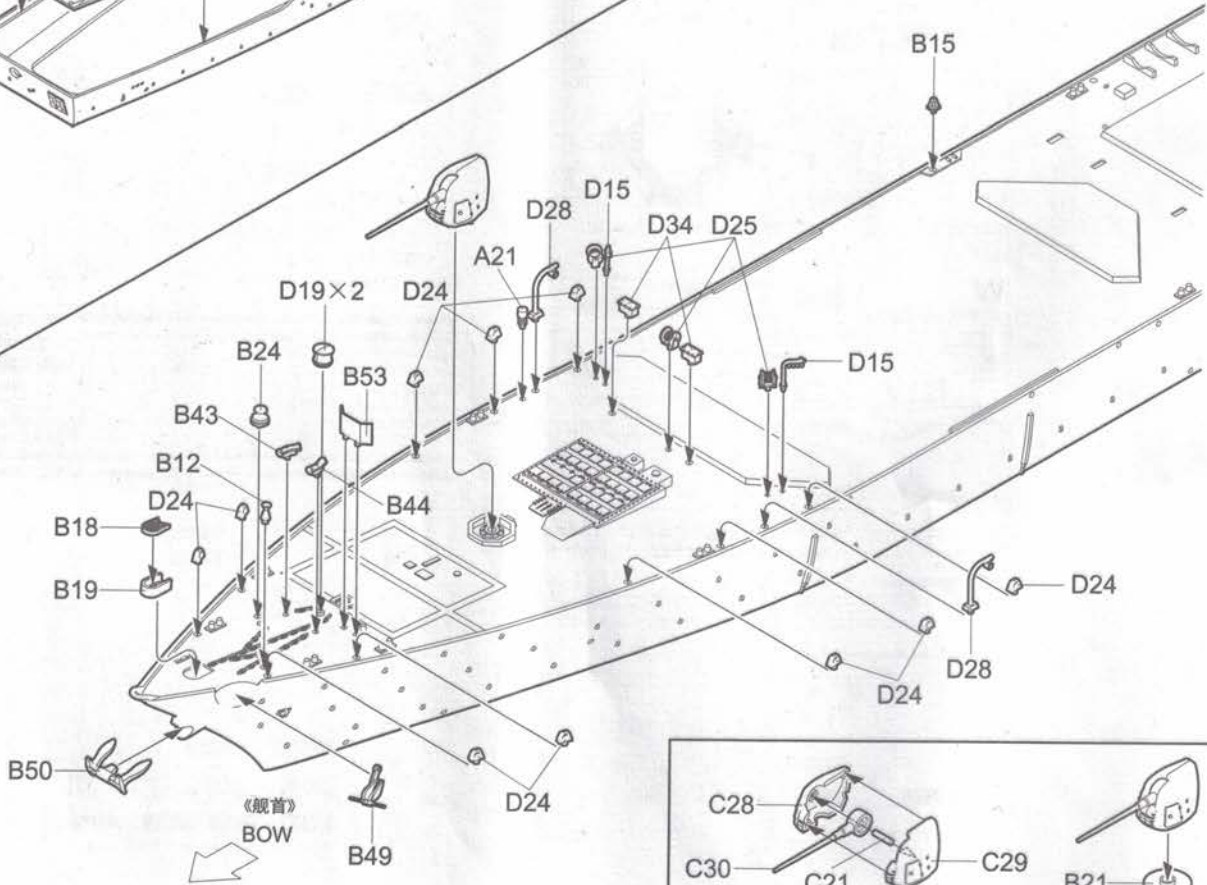

3

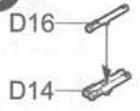

制作2套
Make two

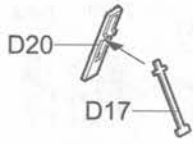

制作2套
Make two

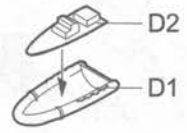

制作2套
Make two

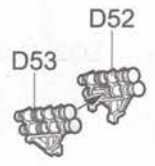

制作2套
Make two

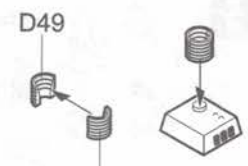
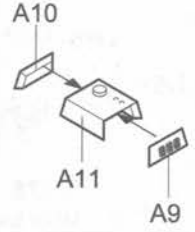

D49

4

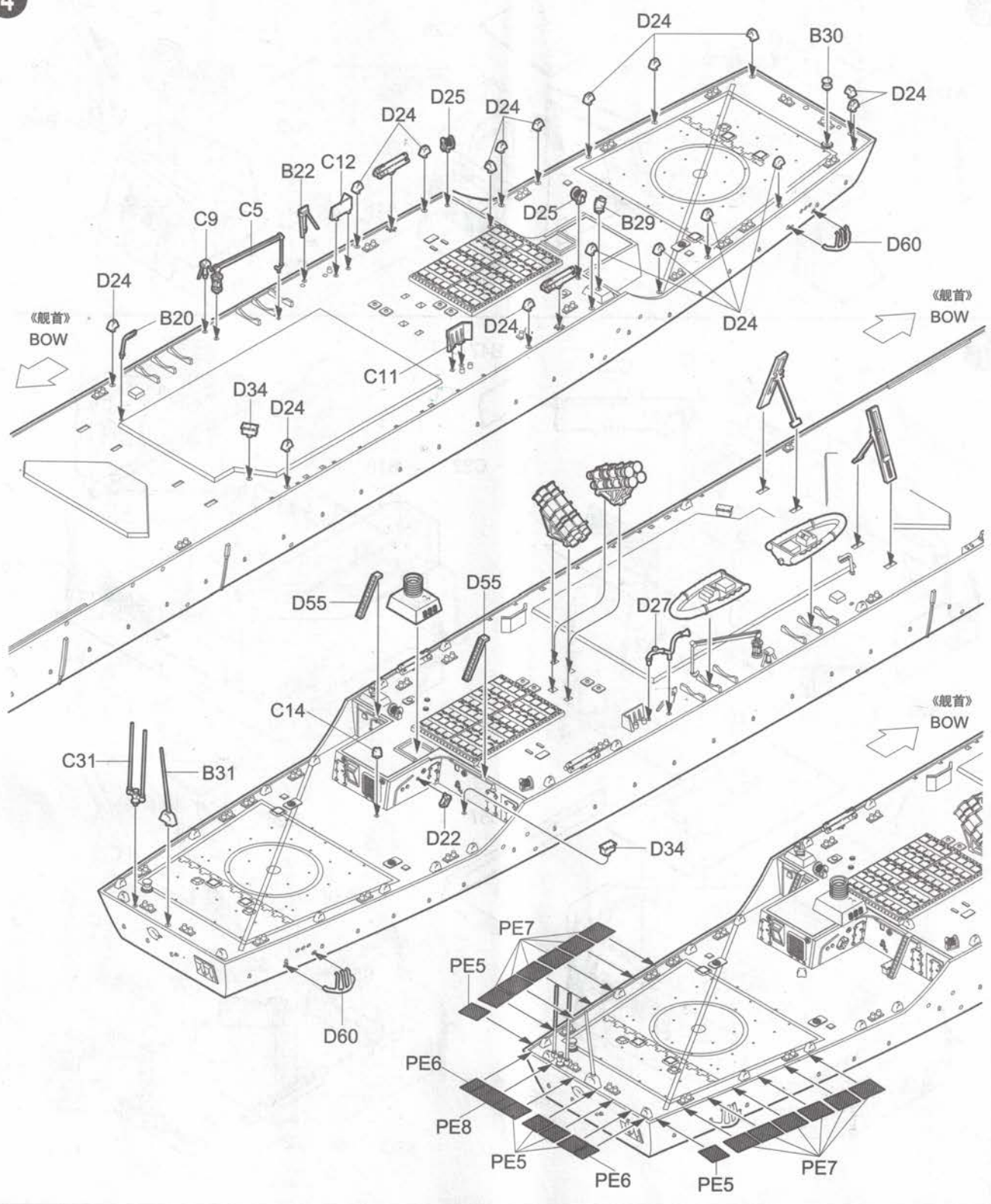

5

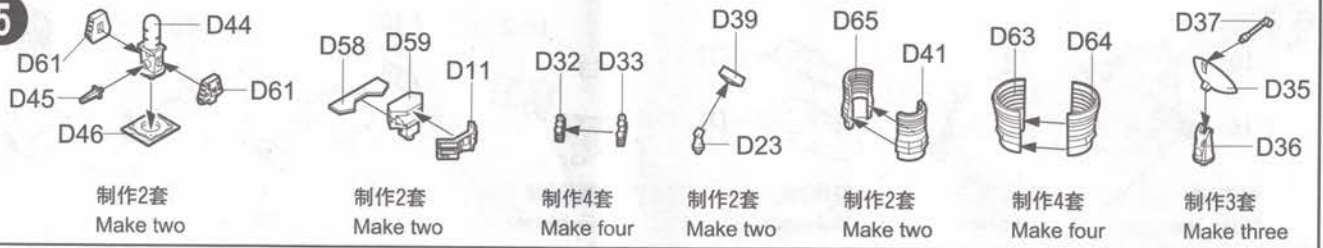

6

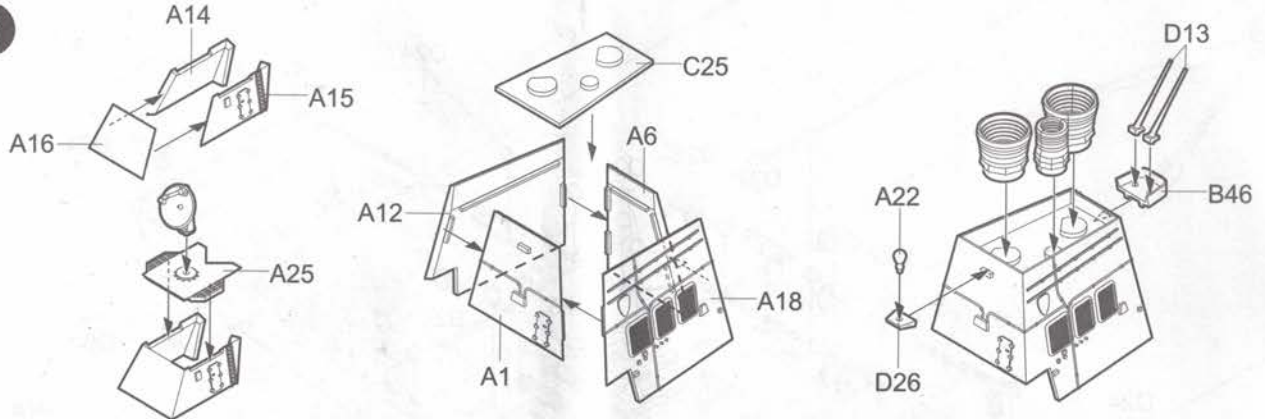

7

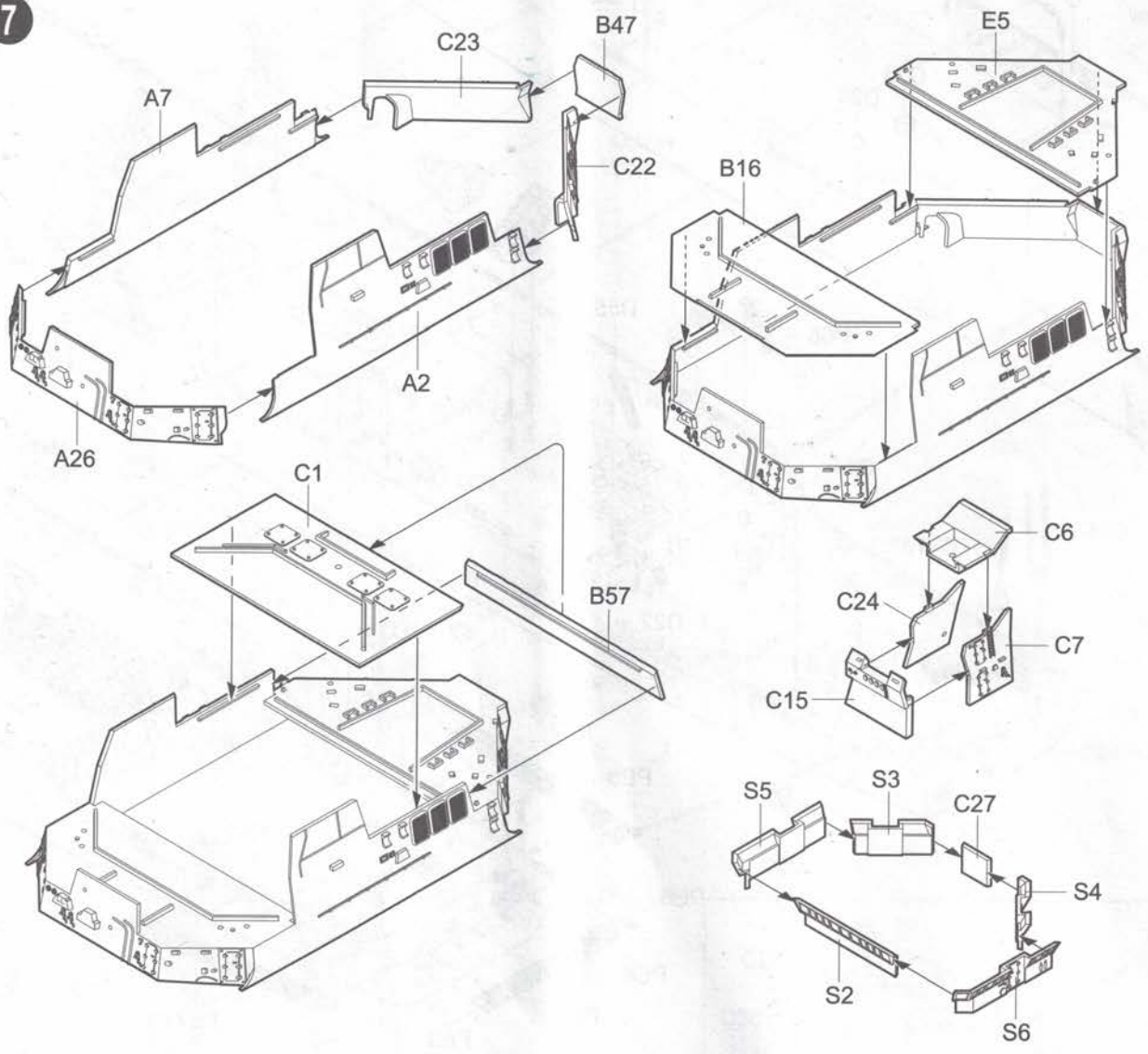

8

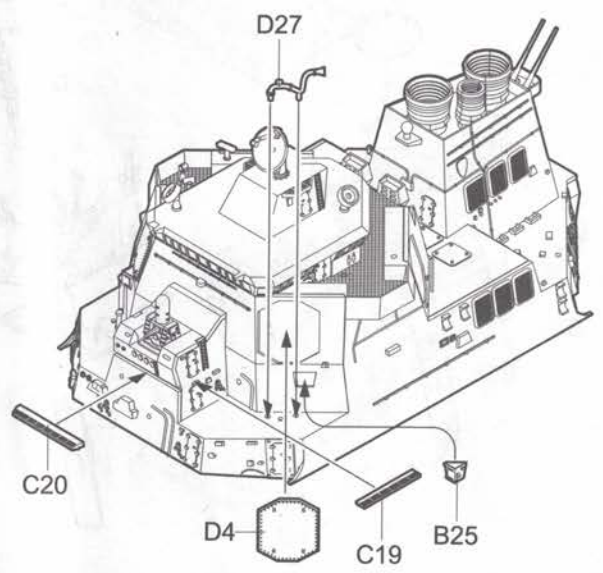
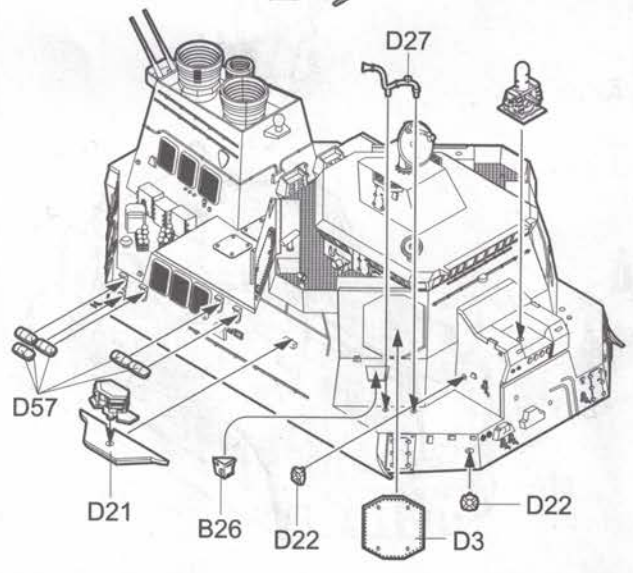
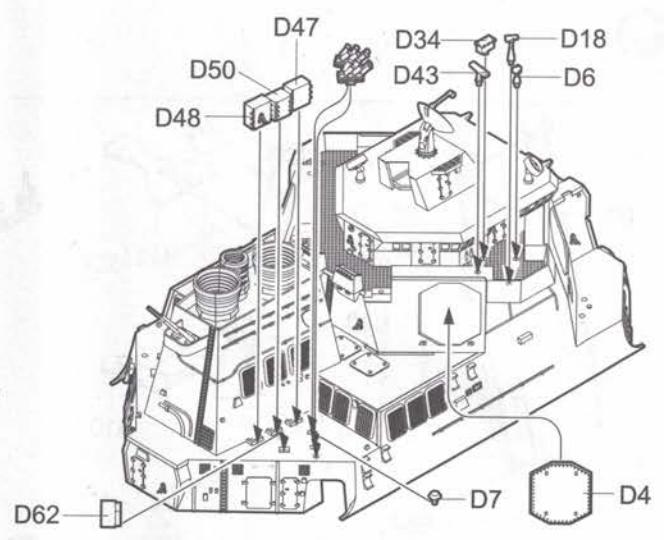
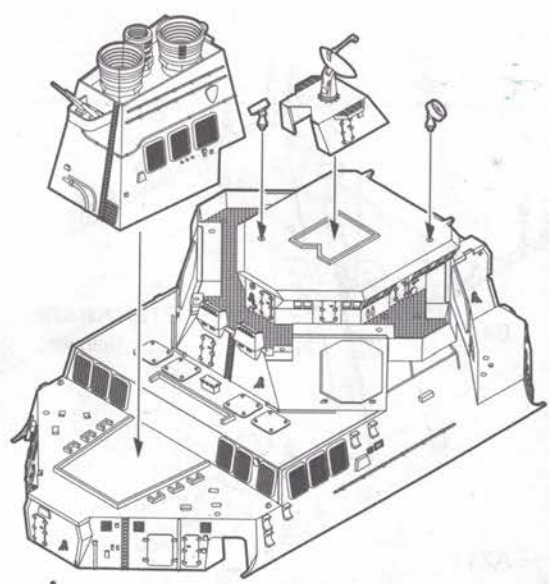
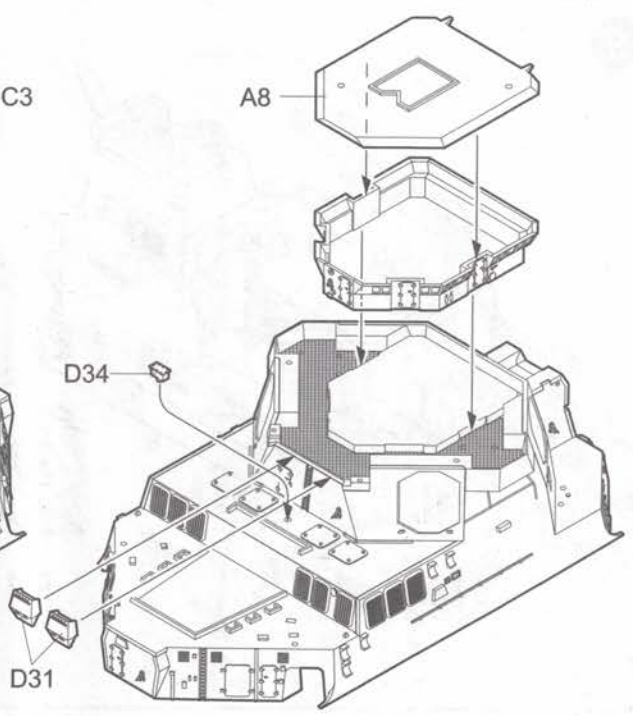
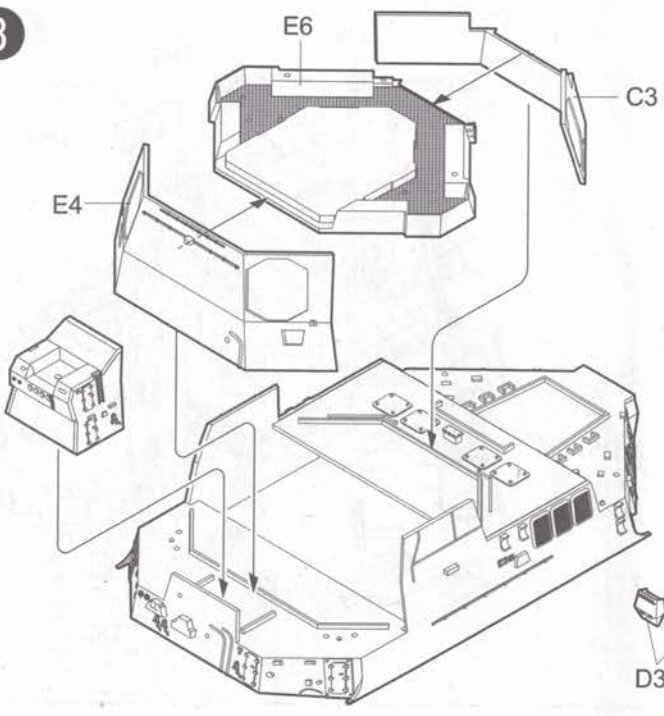

9

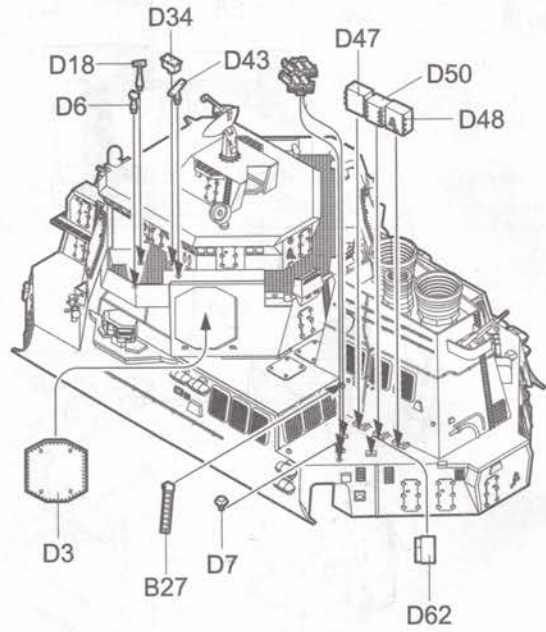
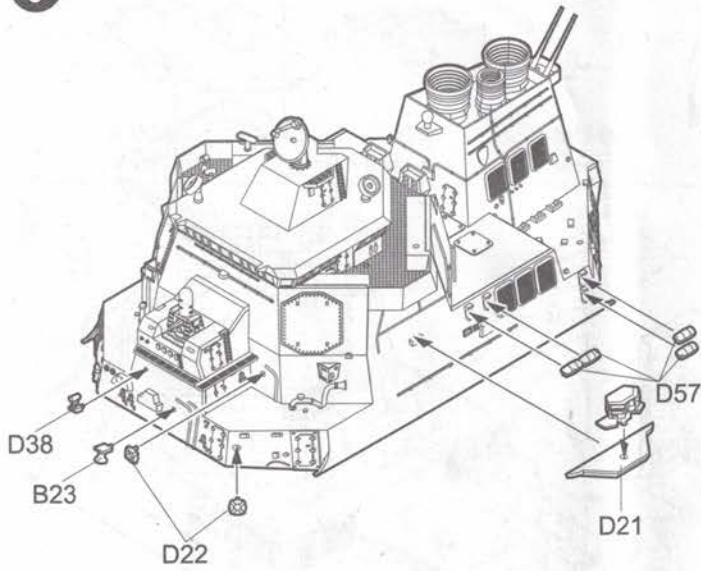

10

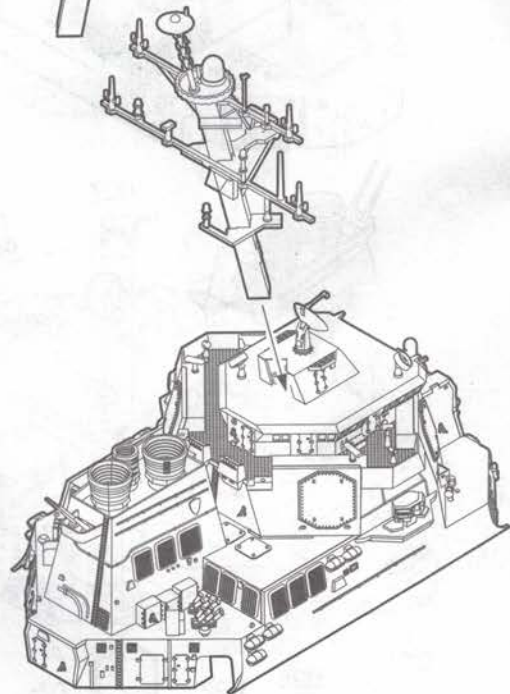
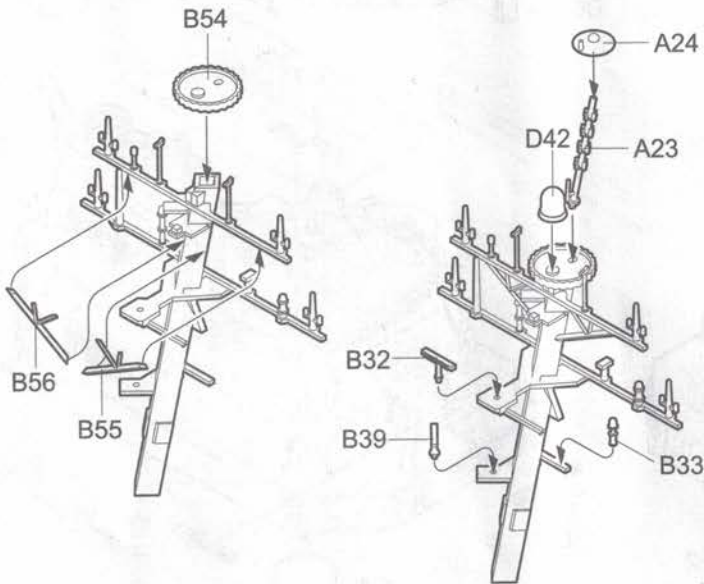
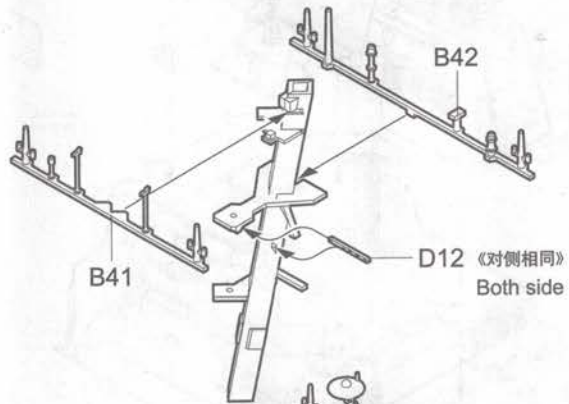
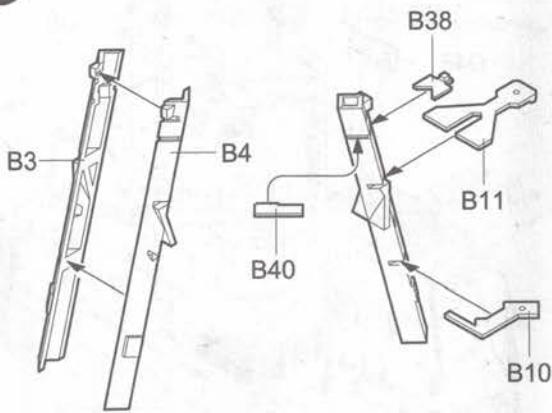

11

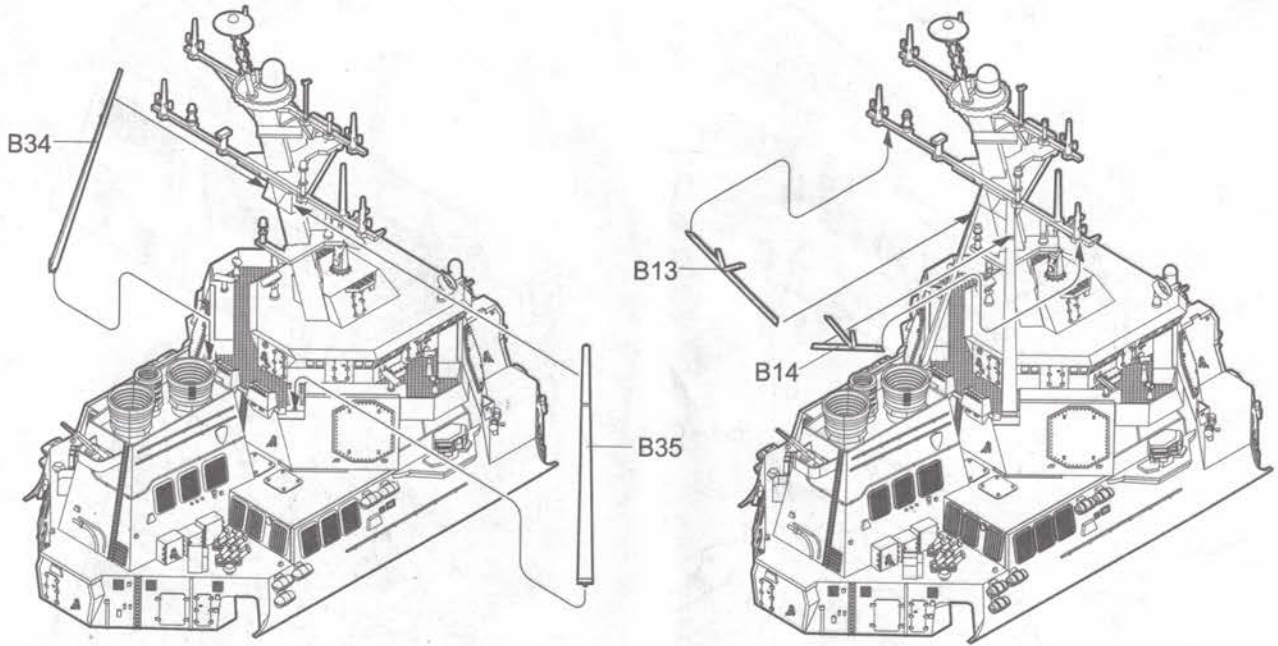

12

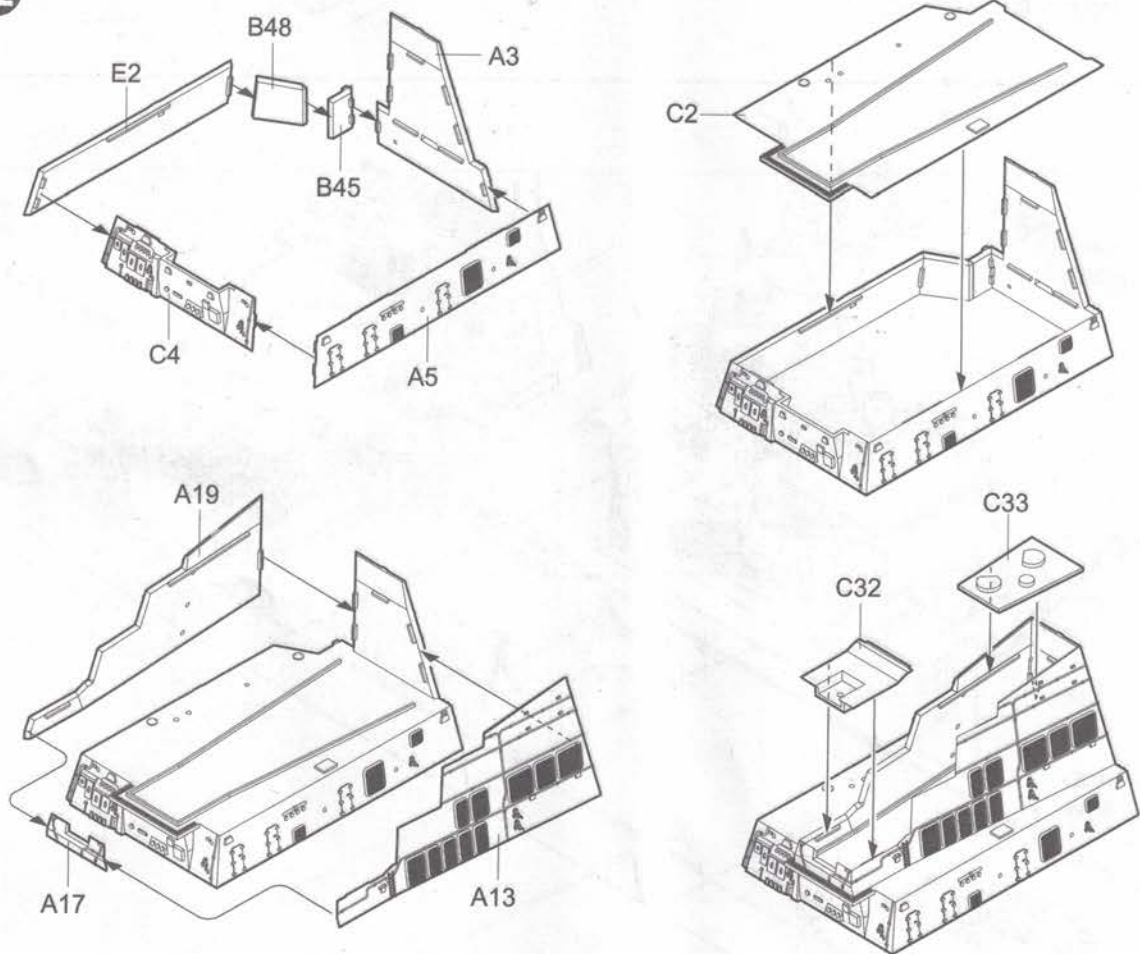

13

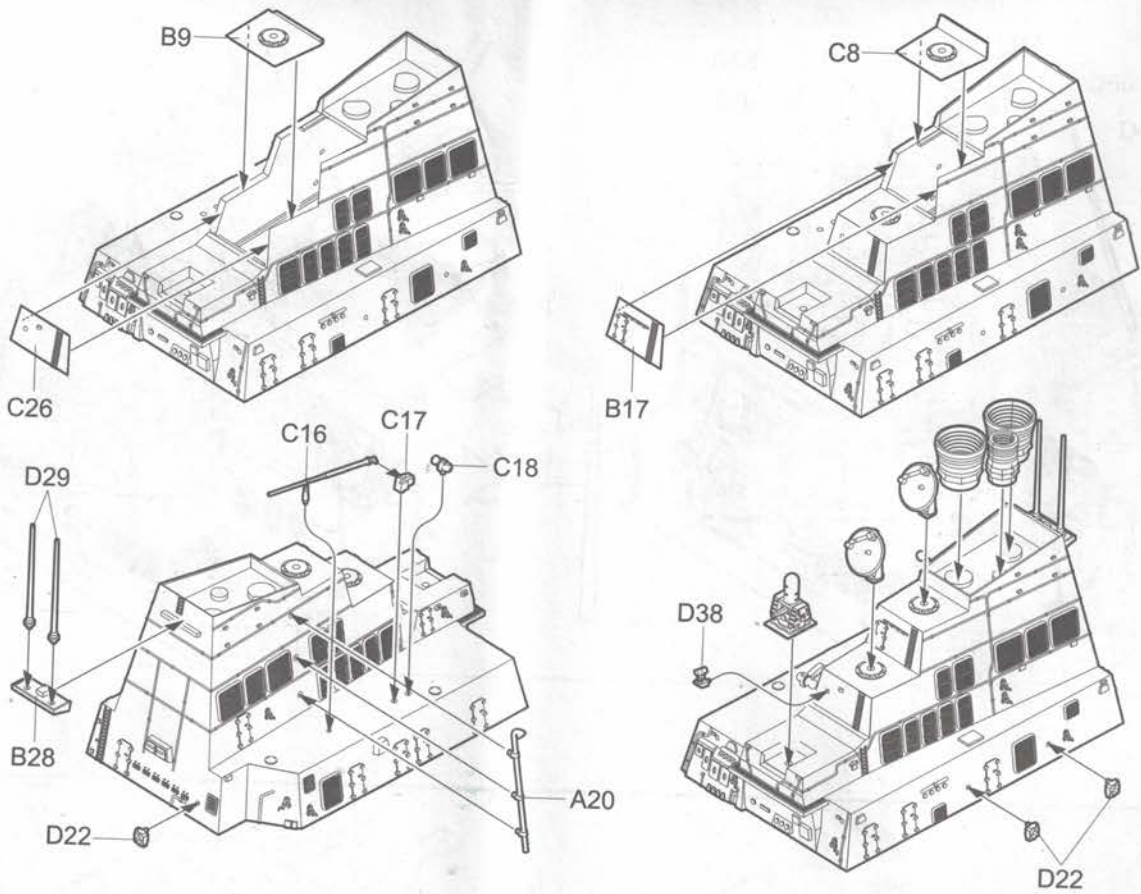

14

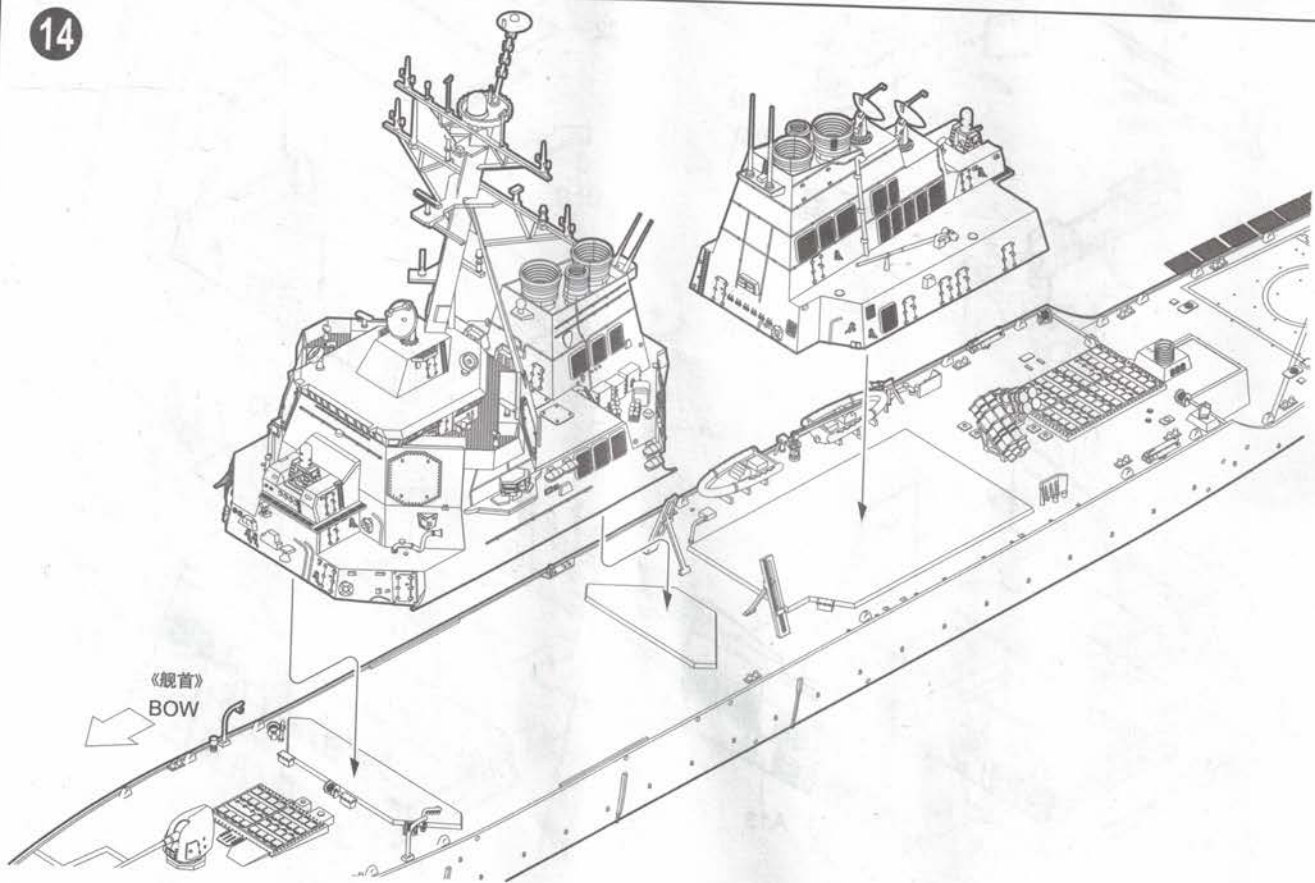

04523

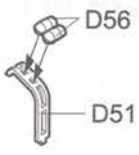

15

制作3套
Make three

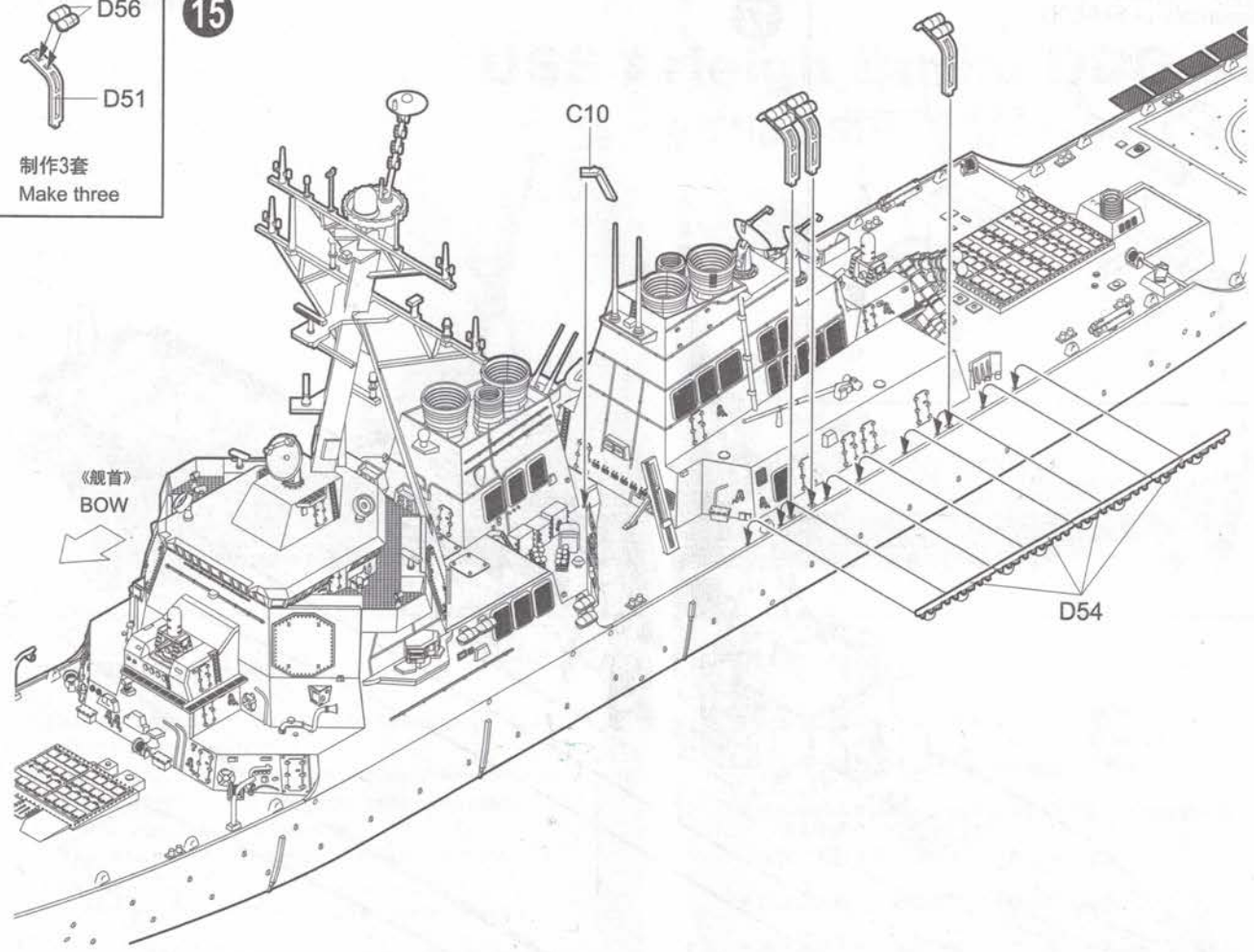

16

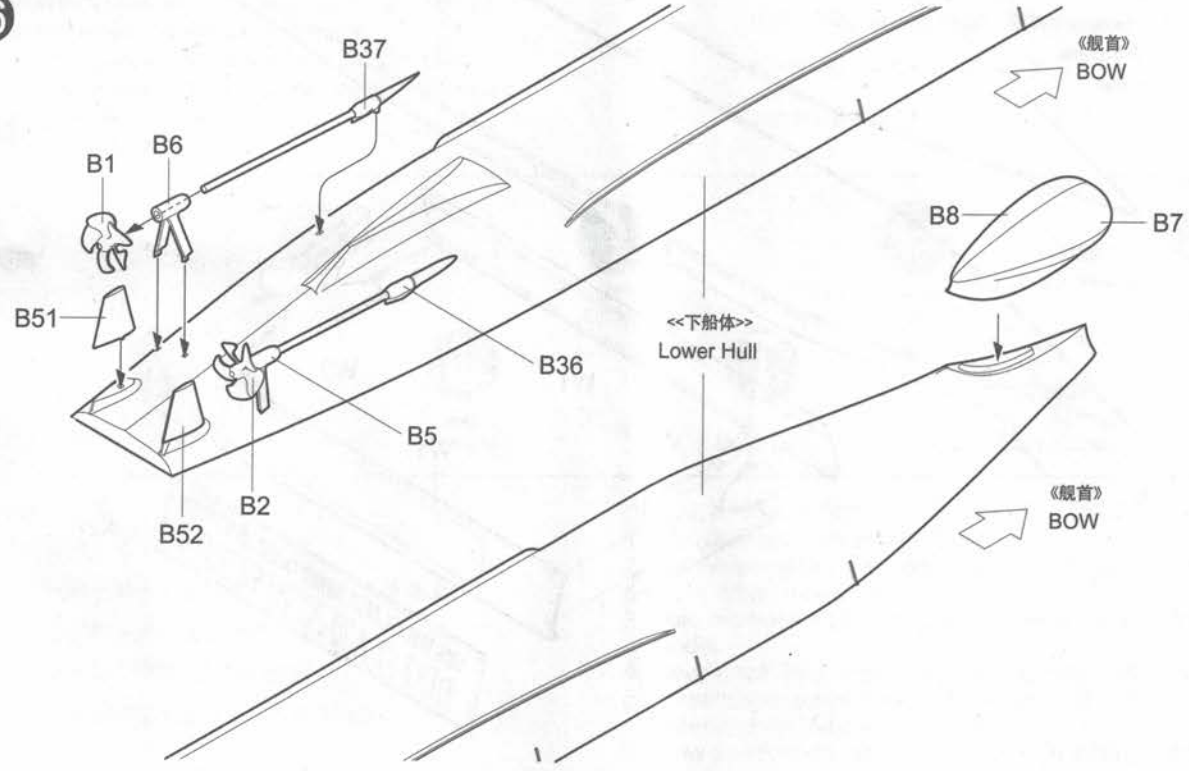

SH-60B 的组装
Assembly of SH-60B

17

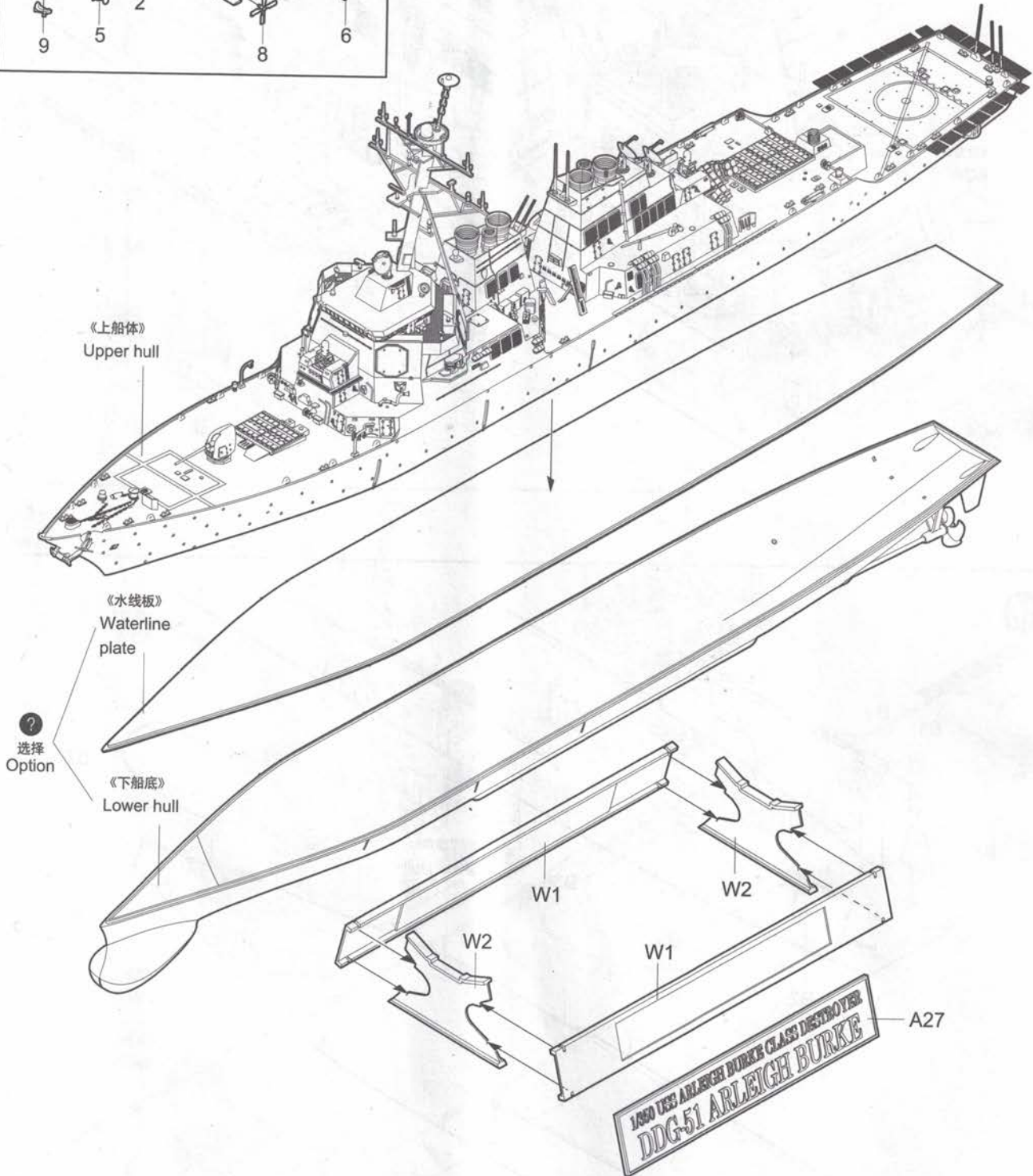
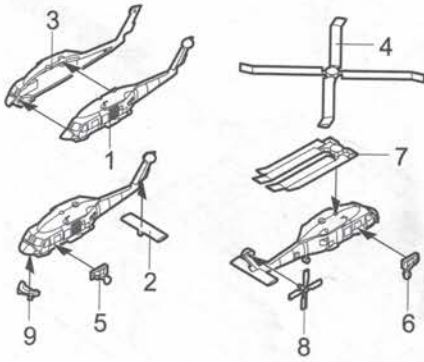

1860 TON ARLEIGH BURKE CLASS DESTROYER
DDG-51 ARLEIGH BURKE