

eduard

LIMITED



Aero L-39C/CM/ZA/ZO

ALBATROS

INSTRUCTION SHEET



2109-NAV1

1/72
DUAL COMBO



Carefully read instruction sheet before assembling. When you use glue or paint, do not use near open flame and use in well ventilated room. Keep out of reach of small children. Children must not be allowed to suck any part, or pull vinyl bag over the head.



Před započatím stavby si pečlivě prostudujte stavební návod. Při používání barev a lepidel pracujte v dobře větrané místnosti. Lepidla ani barvy nepoužívejte v blízkosti otevřeného ohně. Model není určen malým dětem, mohlo by dojít k požití drobných dílů.

INSTRUCTION SIGNS * INSTR. SYMBOL * INSTRUKTION SINNBILDEN * SYMBOLES * 記号の説明



OPTIONAL
VOLBA



BEND
OHNOUT



SAND
BROUSIT



OPEN HOLE
VYVRTAT OTVOR



SYMETRICAL ASSEMBLY
SYMETRICKÁ MONTÁŽ



REMOVE
ODŘÍZNOUT



REVERSE SIDE
OTOČIT



APPLY EDUARD MASK
AND PAINT
POUŽIT EDUARD MASK
NABARVIT

PLEASE CHECK THE LATEST VERSION OF THE INSTRUCTIONS ON www.eduard.com

PARTS



DÍLY



TEILE



PIÈCES



部品

A> 2 pcs.



PLASTIC PARTS

B> 2 pcs.

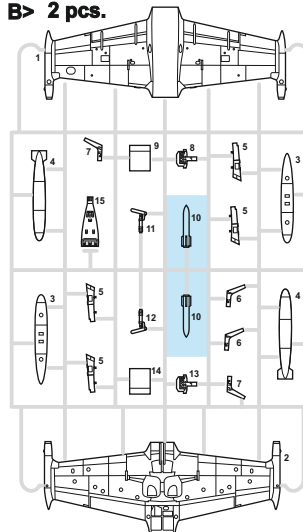

D> 2 pcs.

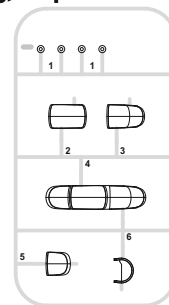

PE - PHOTO ETCHED DETAIL PARTS

2 pcs.

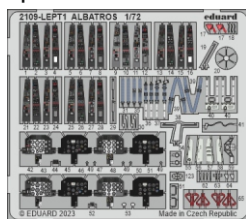

2 pcs.



FILM

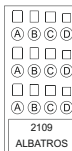

eduard
MASK

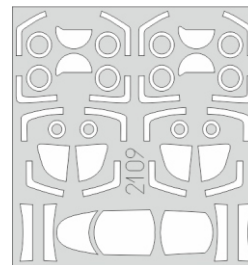

-Parts not for use. -Teile werden nicht verwendet. -Pièces à ne pas utiliser. -Tyto díly nepoužívejte při stavbě. - 使用しない部品

COLOURS



BARVY



FARBEN



PEINTURE



色

GSI Creos (GUNZE)		
AQUEOUS	Mr.COLOR	
H1	C1	WHITE
H2	C2	BLACK
H3	C3	RED
H4	C4	YELLOW
H12	C33	FLAT BLACK
H15	C65	BRIGHT BLUE
H23	C79	SHINE RED
H24	C58	ORANGE YELLOW
H25	C34	SKY BLUE
H32	C40	FIELD GRAY
H34	C39	YELLOW
H37	C43	WOOD BROWN
H50	C135	GREEN
H51	C11	LIGHT GREY
H57	C73	AIRCRAFT GRAY
H58	C351	INTERIOR GREEN
H68	C36	RLM74 DARK GRAY
H77	C137	TIRE BLACK
H85	C85	SAIL COLOR
H90	C47	CLEAR RED
H94	C138	CLEAR GREEN
H303	C303	GREEN

GSI Creos (GUNZE)		
AQUEOUS	Mr.COLOR	
H304	C304	OLIVE DRAB
H305	C305	GRAY
H306	C306	MEDIUM GRAY
H307	C307	GRAY
H308	C308	GRAY
H309	C309	GREEN
H311	C311	GRAY
H313	C313	YELLOW
H319	C319	LIGHT GREEN
H325	C325	GRAY
H336	C336	HEMP
H338	C338	LIGHT GRAY
H405	C126	OLIVE GREEN
H418	C118	RLM78 LIGHT BLUE
	C74	AIR SUPERIORITY BLUE
	C391	INTERIOR GREEN
Mr.METAL COLOR		
MC211		CHROME SILVER
MC213		STEEL
MC214		DARK IRON
MC218		ALUMINIUM

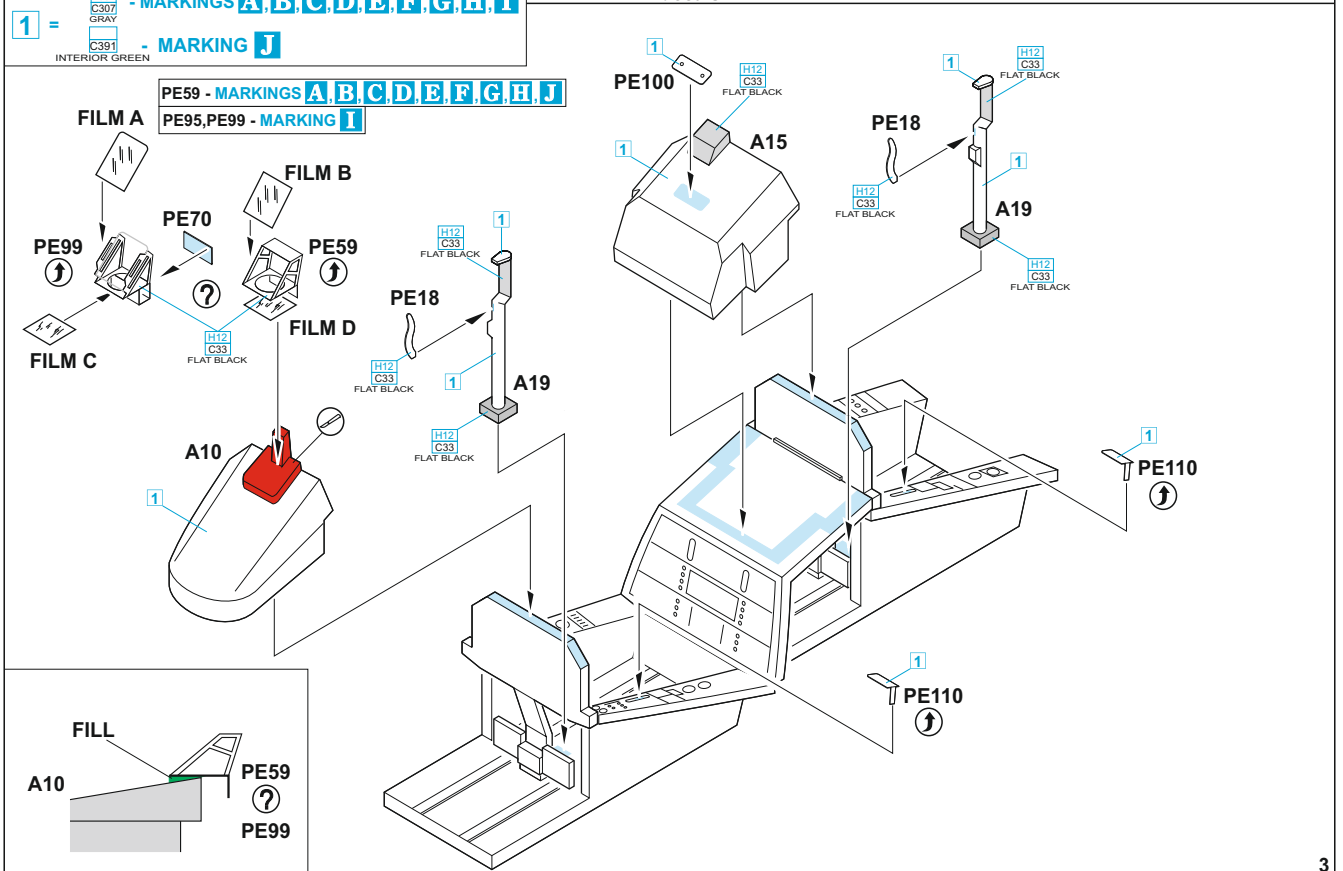
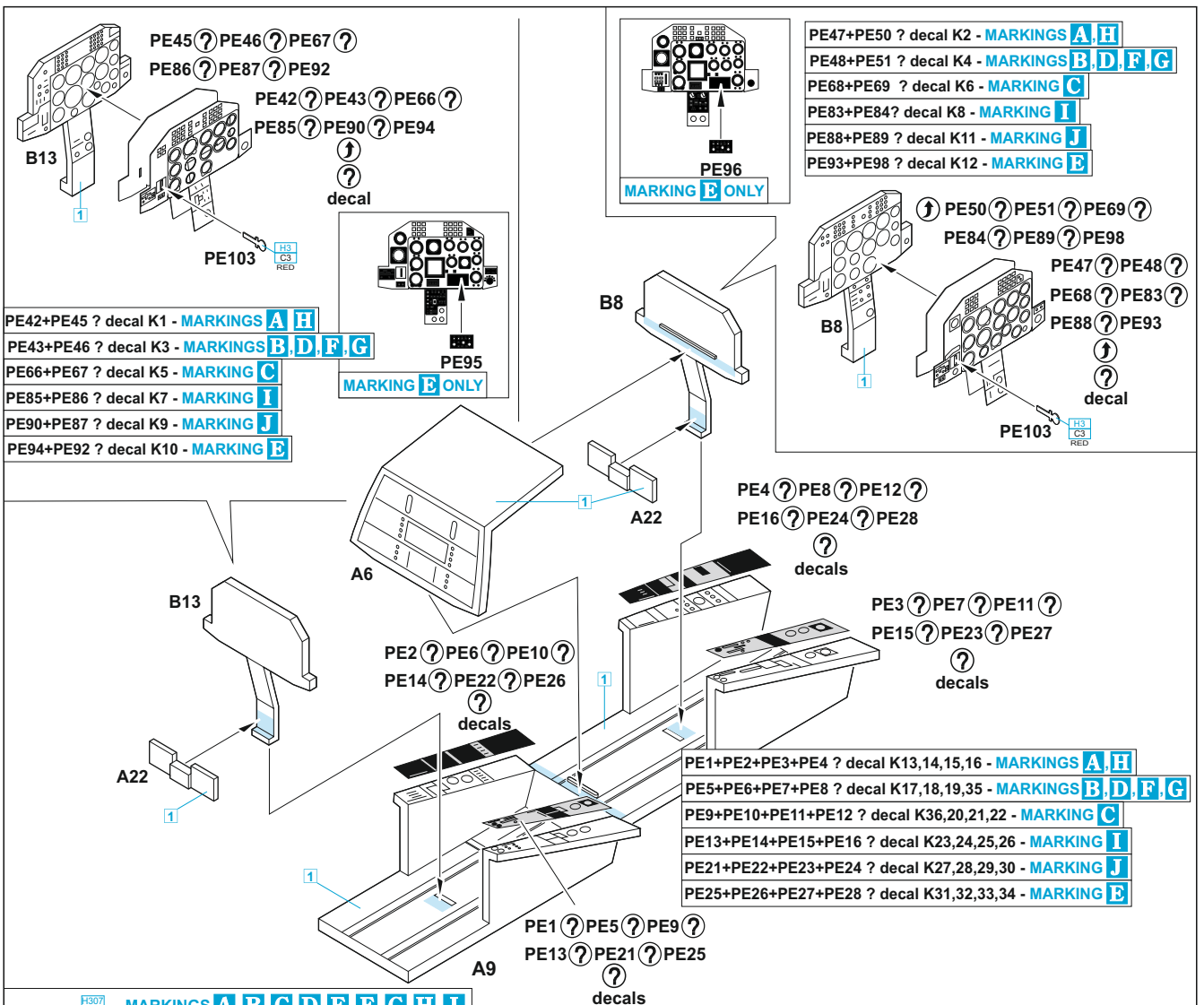

PE57+PE58 - MARKINGS **A, B, C, D, E, F, G, H, I**

PE106+PE107 - MARKING **J**

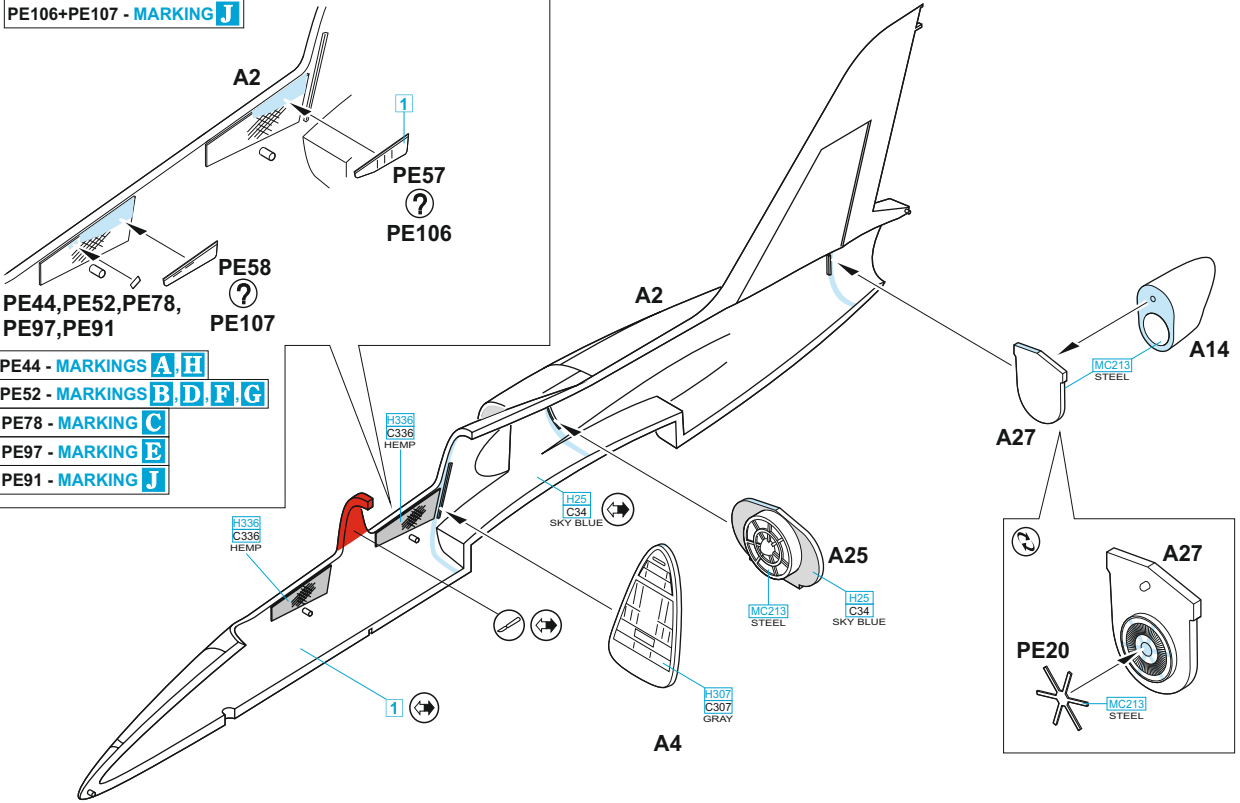

PE44 - MARKINGS **A, H**

PE52 - MARKINGS **B, D, F, G**

PE78 - MARKING **C**

PE97 - MARKING **E**

PE91 - MARKING **J**

PE44, PE52, PE78, PE97, PE91

PE58

PE107

PE57

PE106

A2

A27

A25

A4

A14

A27

PE20

MC213 STEEL

MC213 STEEL

MC213 STEEL

MC213 STEEL

MC213 STEEL

MC213 STEEL

MC213 STEEL

MC213 STEEL

MC213 STEEL

MC213 STEEL

MC213 STEEL

MC213 STEEL

MC213 STEEL

MC213 STEEL

MC213 STEEL

MC213 STEEL

MC213 STEEL

MC213 STEEL

MC213 STEEL

MC213 STEEL

MC213 STEEL

MC213 STEEL

MC213 STEEL

MC213 STEEL

MC213 STEEL

MC213 STEEL

MC213 STEEL

MC213 STEEL

MC213 STEEL

MC213 STEEL

MC213 STEEL

MC213 STEEL

MC213 STEEL

MC213 STEEL

MC213 STEEL

MC213 STEEL

MC213 STEEL

MC213 STEEL



Don't forget to add the nose weight balance!

PE55+PE56 - MARKINGS **A, B, C, D, E, F, G, H, I**

PE104+PE105 - MARKING **J**

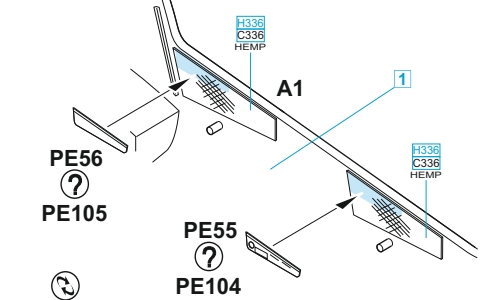

2 pcs.

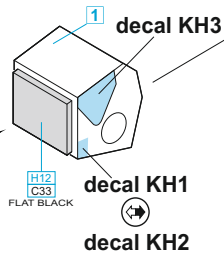
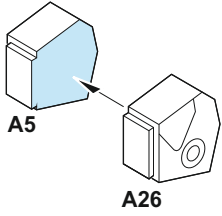

decal KH1,KH2,KH3 - MARKING J ONLY

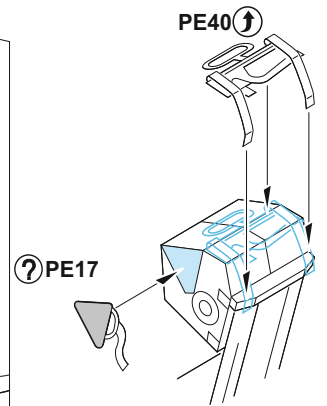
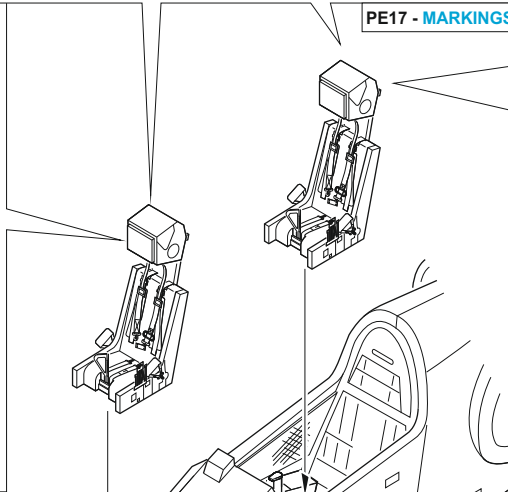
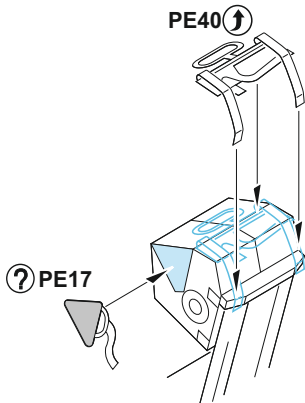
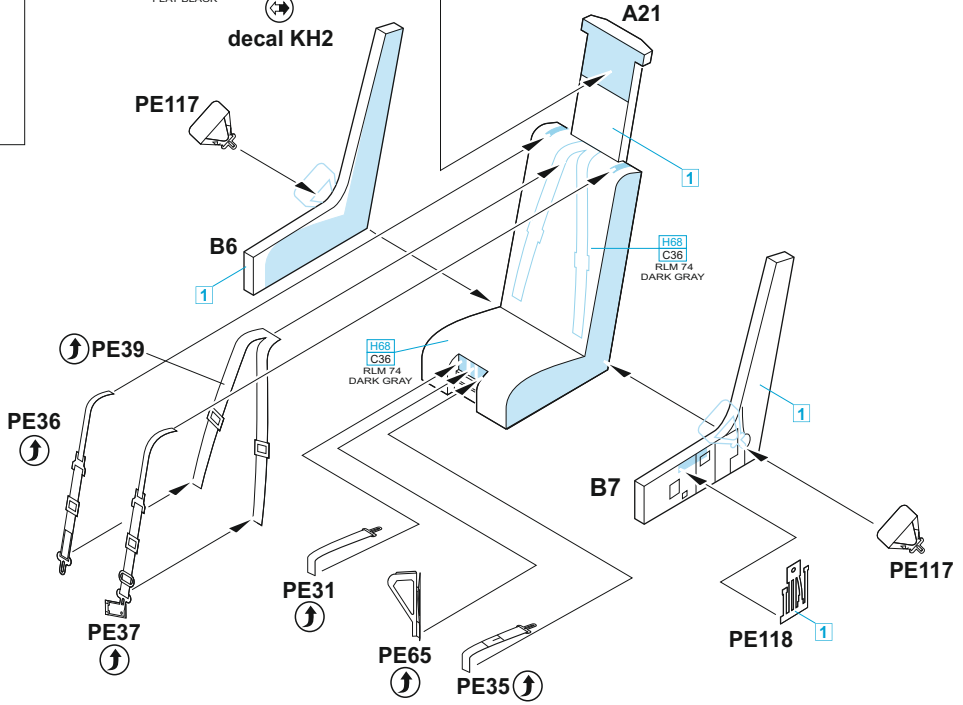

PE17 - MARKINGS A,B,C,D,E,F,G,H,I ONLY

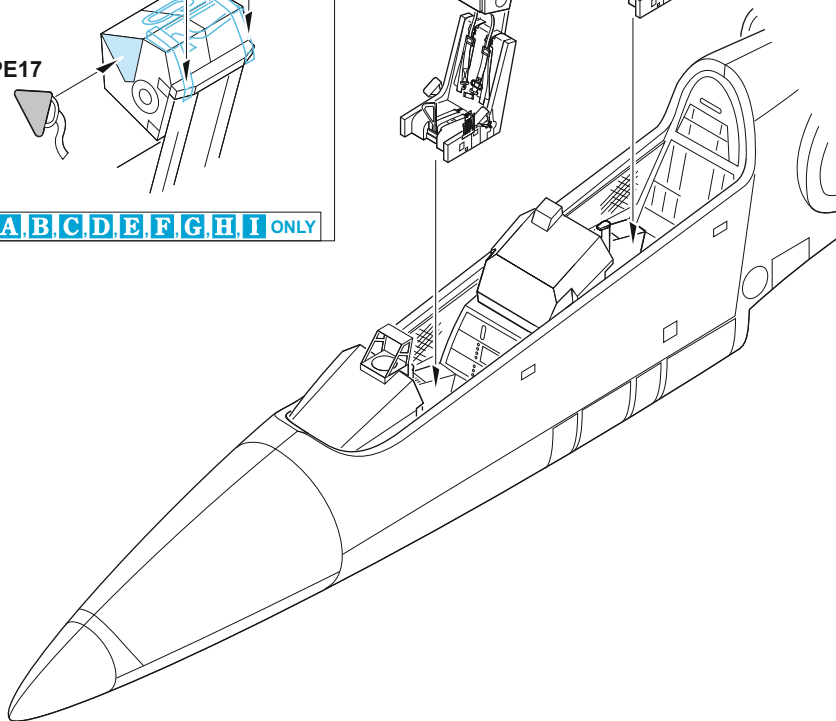

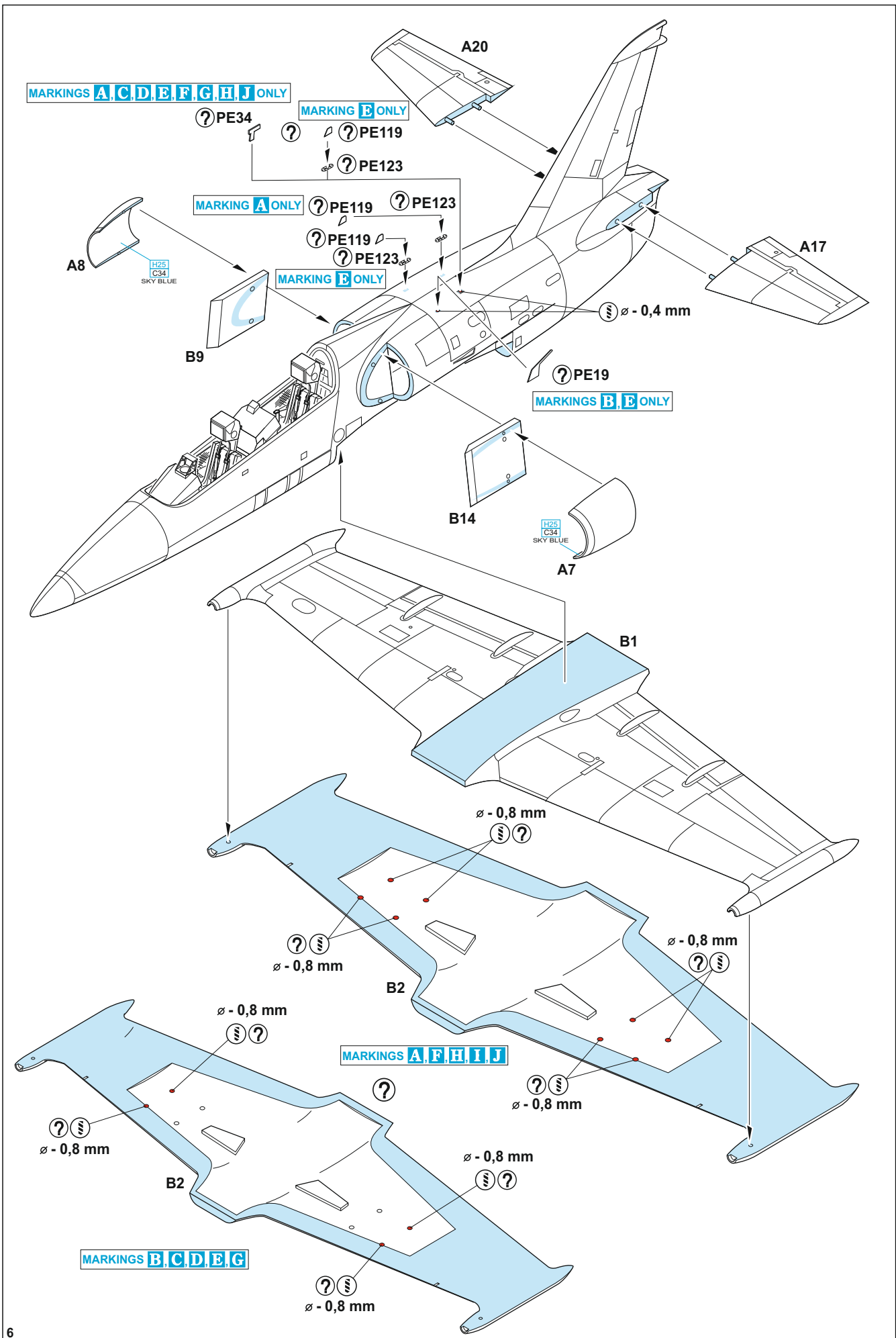

MARKINGS A, I ONLY

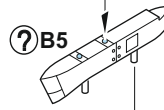
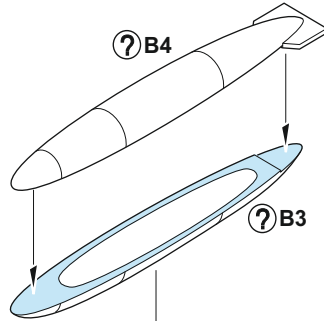
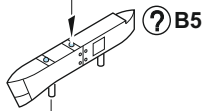
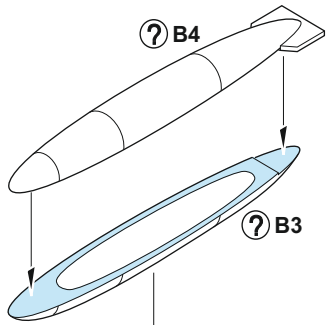
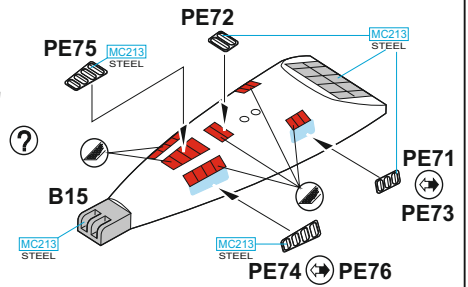
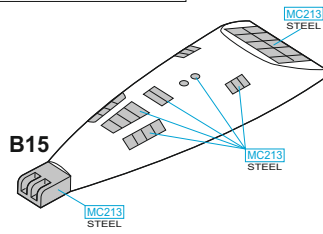

PE38 - MARKING A ONLY
PE109 - MARKING E ONLY
PE113 - MARKINGS B, D, F ONLY

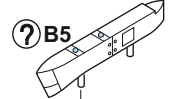
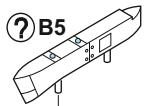

MARKINGS A, I ONLY

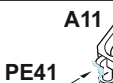

PE124 - MARKING E ONLY



MARKINGS B, C, F, G, J ONLY

MARKING I ONLY

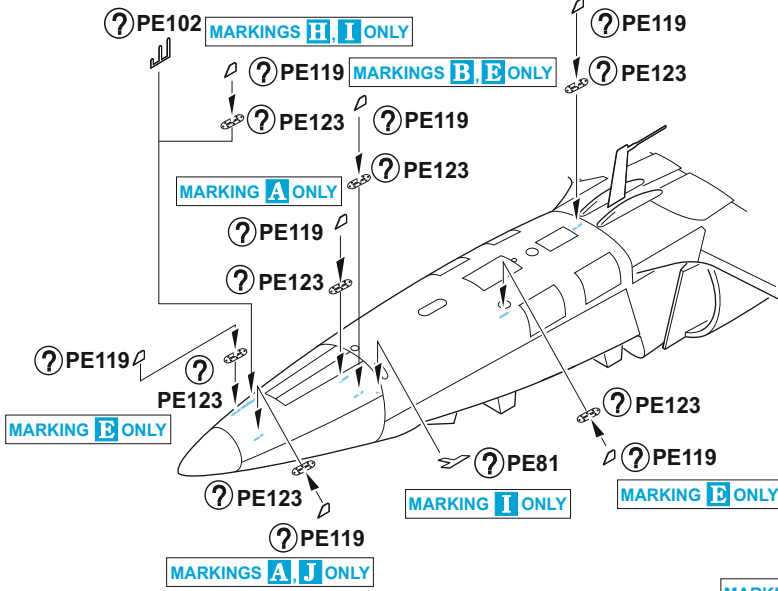

MARKING I ONLY

MARKING I ONLY

MARKING I ONLY

MARKINGS A, D, E, H, I ONLY

MARKINGS B, C, D, F, G, J ONLY

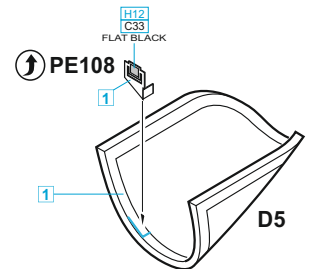
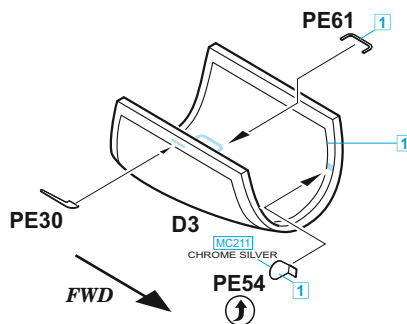
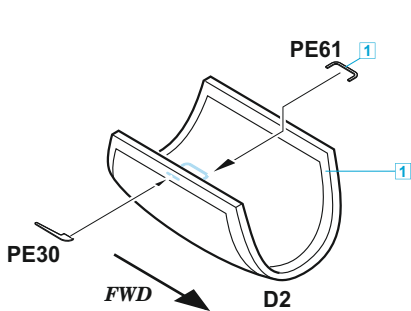
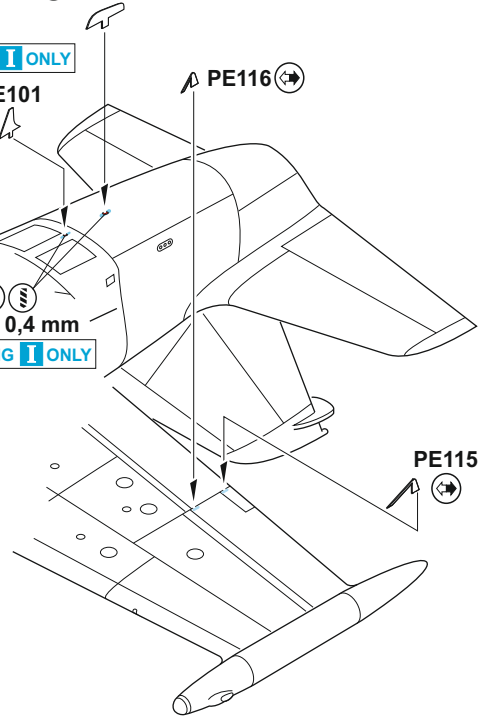
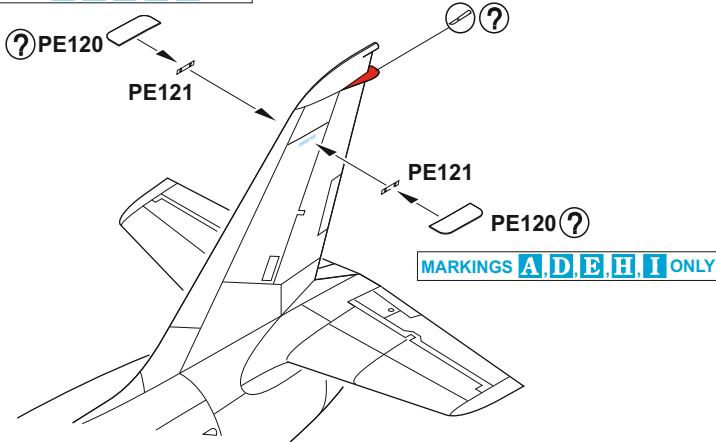

OPEN CANOPY

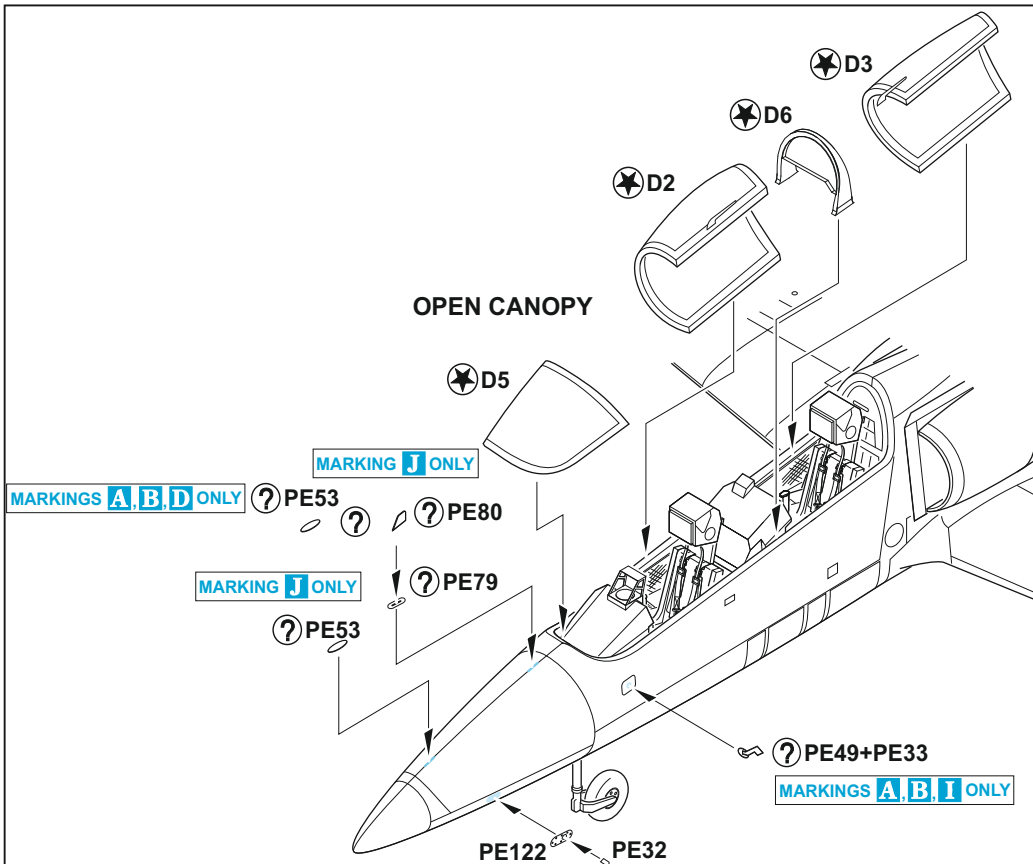

CLOSED CANOPY

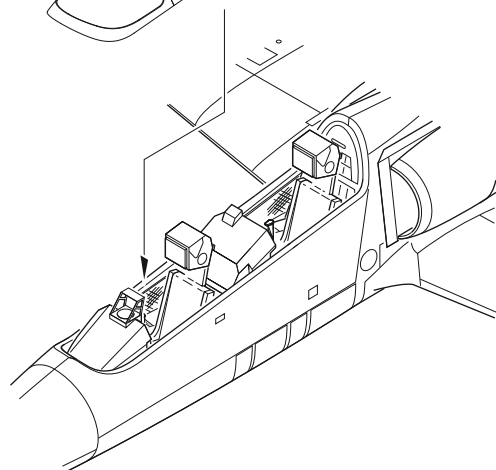
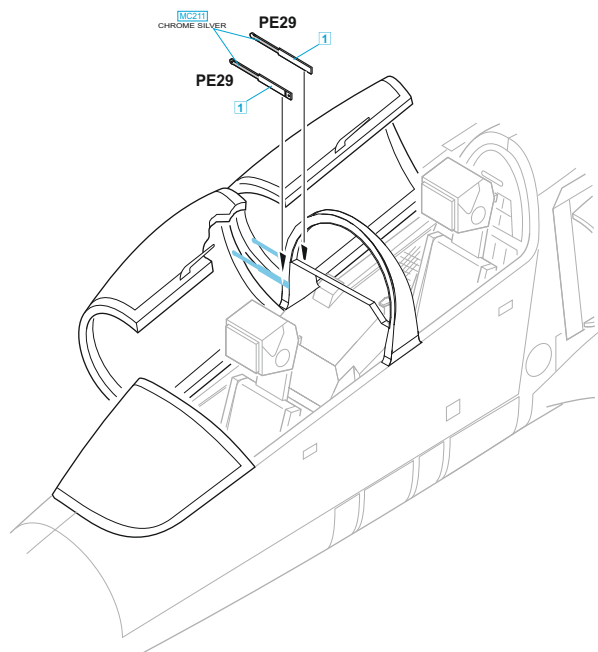
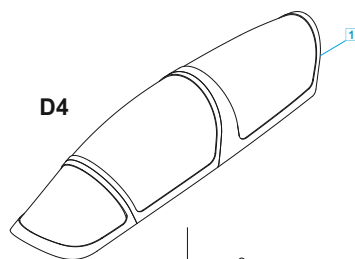

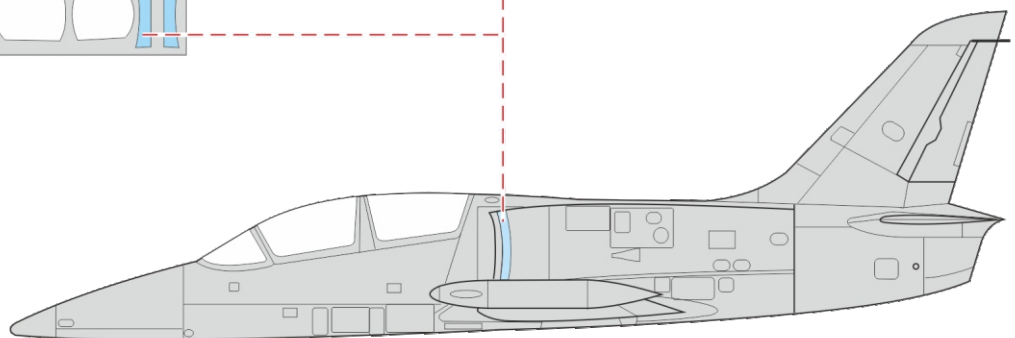
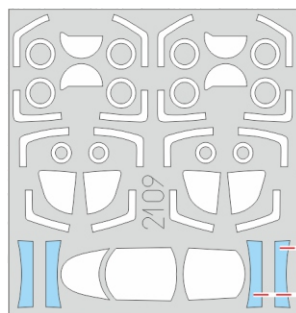
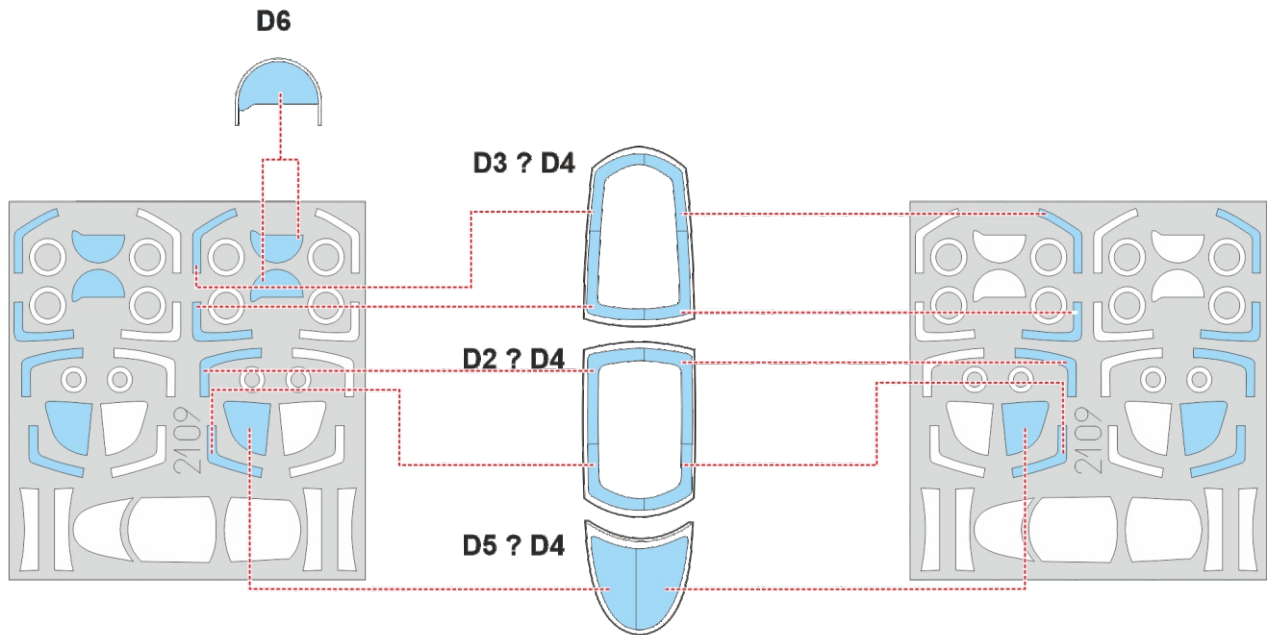
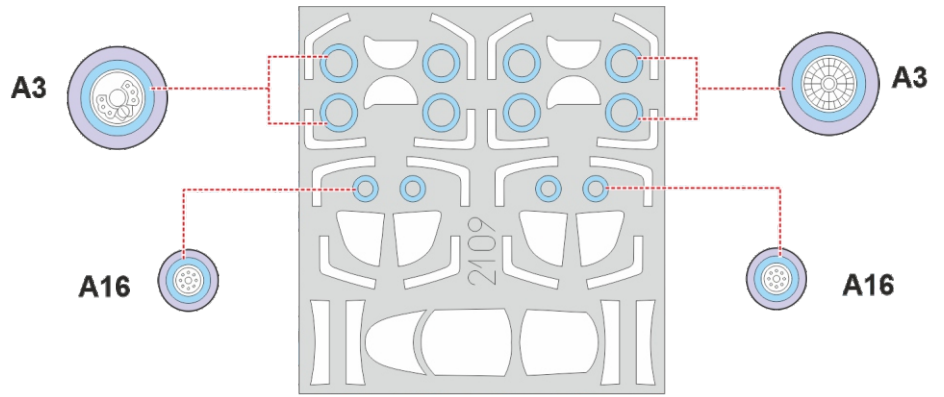

A L-39ZA, s/n 232433, 222 Training Squadron, Náměšť nad Oslavou AFB, Czech Air Force, Czech Republic, 2008-2010

The first flight of the Albatros with serial number 232433 took place on November 24, 1982, piloted by the crew Pánek-Křemen. On December 13, the military administration took over the aircraft. It was incorporated into the 30 Fighter-Bomber Air Regiment in Hradec Králové on December 23, 1982, and later moved to Pardubice. By the late 1980s, it was assigned to the 8 Fighter-Bomber Air Regiment in Mošnov, later Brno-Tuřany, where it was used primarily in the AA role against the slow and low altitude flying targets. After the 8 Fighter-Bomber Air Regiment was disbanded, the aircraft was transferred to various units, including the 82 Fighter Squadron in Mošnov and the 4 Fighter Squadron in Přerov. From January 1, 1995, it served with the 41 Fighter Squadron at the 4 Tactical Air Force Base in Čáslav. In 2003, it underwent a major overhaul in LOZ České Budějovice, receiving a new glossy camouflage and round tactical numbers on its fuselage. It was later integrated into the 221 Tactical Squadron at the 22 Air Base in Náměšť nad Oslavou. In 2008, the aircraft was selected for a special paint scheme to celebrate the 40th anniversary of the first L-39 flight. The anniversary livery depicted an albatross in flight on the right side, and the left side featured the image of the main L-39 designer, Ing. Jan Vlček, along with his signature. The anniversary Albatros was showcased at various public events. It was eventually assigned to the 222 Training Squadron at Náměšť nad Oslavou Air Base. Its last flight occurred on November 25, 2010, after which it was retired. In 2013, it was transported to Čáslav by land and later transferred to the Kbely Aviation Museum after four years of storage in Čáslav. The aircraft, registered as "2433," logged impressive 3,545 flight hours and 4,898 take-offs.

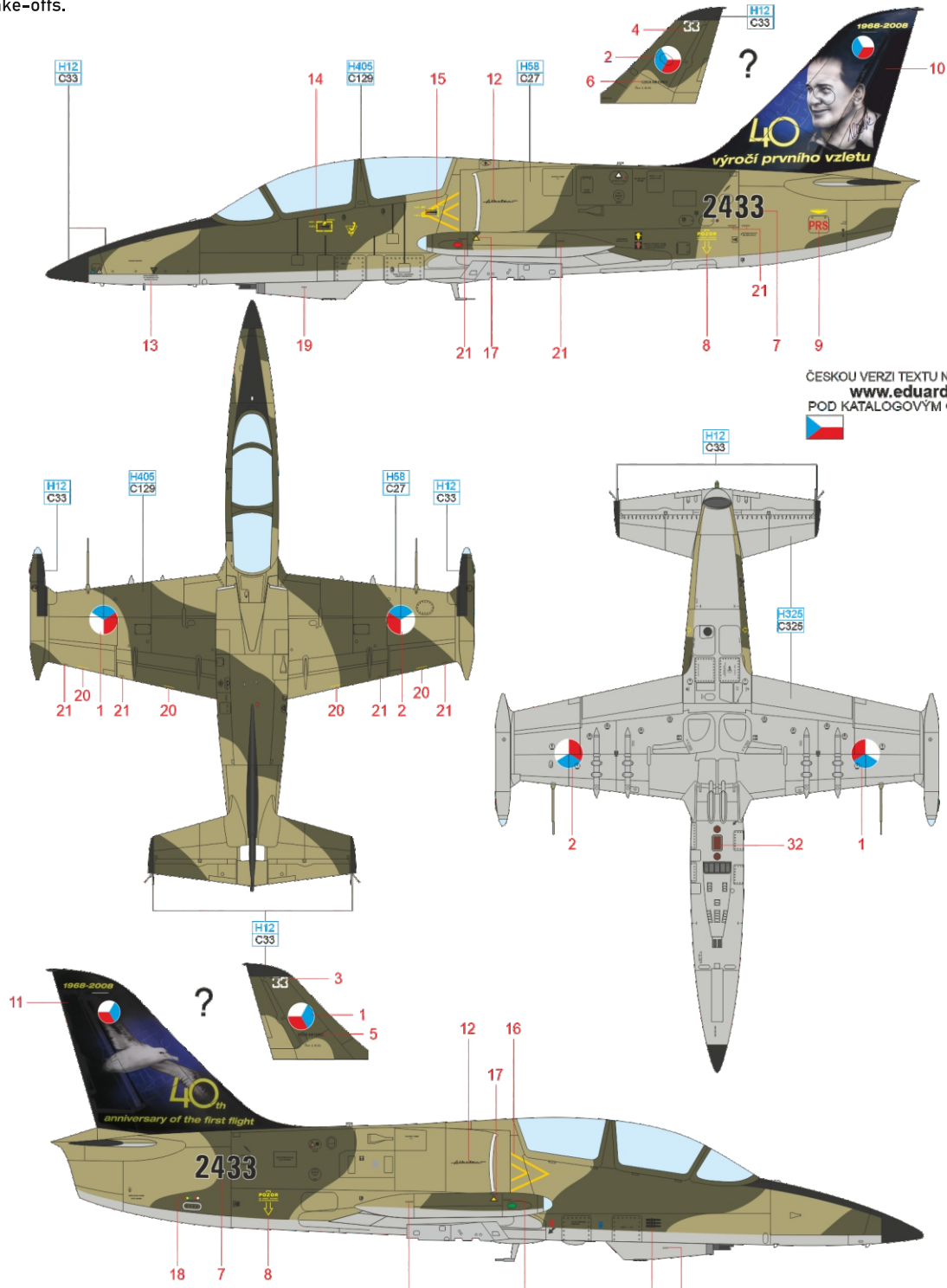

ČESKOU VERZI TEXTU NALEZNETE NA www.eduard.com POD KATALOGOVÝM ČÍSLEM 2109

- GRAY H325 C325
- OLIVE GREEN H405 C129
- GREEN H58 C27
- FLAT BLACK H12 C33

B L-39C, pplk. Ing. Ivan Chvojka, Sliač AFB, Slovak Air Force, Slovakia, 1991-2004

The aerobatic team "Biele Albatrosy" (White Albatrosses) performed their routine flying L-39 Albatros aircraft manufactured by Aero Vodochody. The team operated from 1991 to 2004. Initially, they practiced flying in a trio formation and made their first public appearance with six aircraft in May 1991. By the end of 1991, the team adopted the name "Biele Albatrosy." In the summer of 1992, all six aircraft received a new Slovak national color scheme at Aero Vodochody, replacing the original camouflage. From 1995, the team operated seven aircraft, with one aircraft flying solo during rearrangements outside the audience's view. The Biele Albatrosy achieved success not only in the Czech Republic and Slovakia but also at the international air shows in countries including England, France, Denmark, Italy, Hungary, and the Netherlands. The team was led by military pilot Ivan Chvojka.

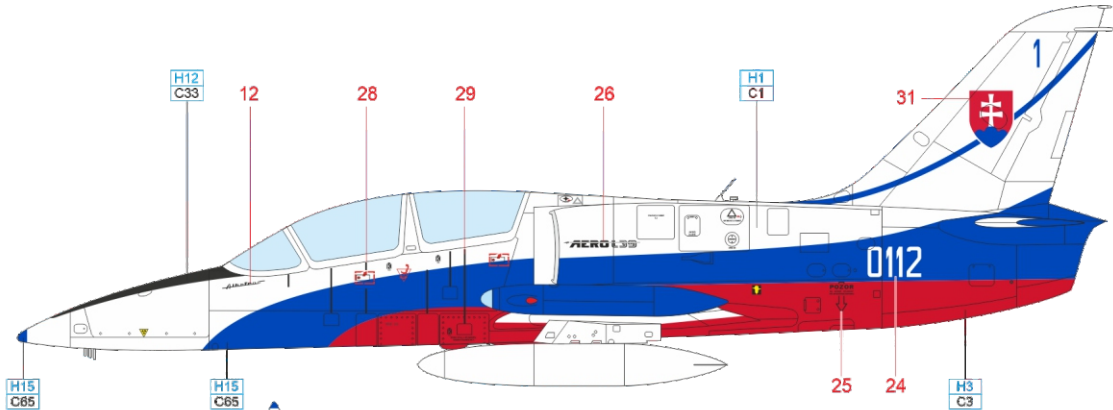

ČESKOU VERZI TEXTU NALEZNETE NA
www.eduard.com
 POD KATALOGOVÝM ČÍSLEM 2109

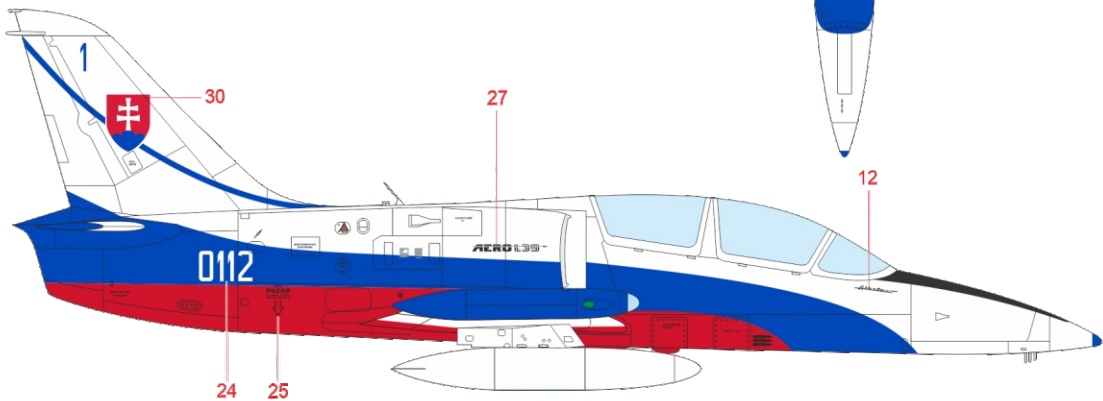
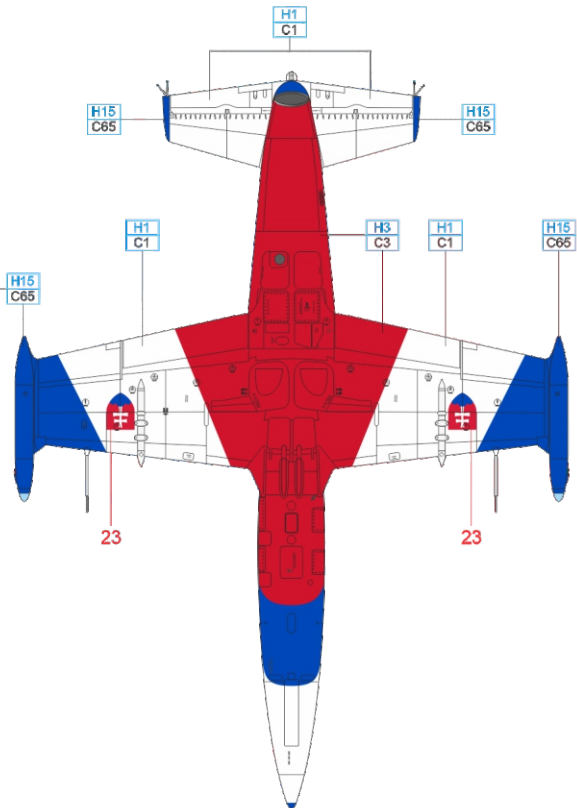
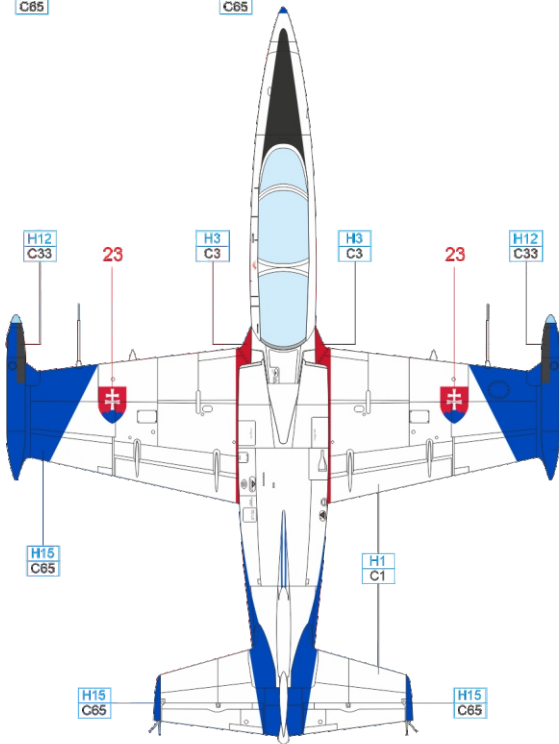

WHITE	H1 C1	RED	H3 C3	BLUE	H15 C65	FLAT BLACK	H12 C33
-------	----------	-----	----------	------	------------	------------	------------

eduard

C L-39C, s/n 530443, High Military Aviation School, Košice AB, Czechoslovak Air Force, Czechoslovakia, 1974

In aviation training, the subsonic jet trainer L-39 Albatros plays an indispensable role. The first flight of the prototype X-02 took place on November 4, 1968. The Czechoslovak People's Army logically became the first user of L-39 aircraft. At that time, the Military Aviation College in Košice, provided training for military pilots throughout Czechoslovakia. The early series L-39C aircraft were delivered with a white upper fuselage. The lower fuselage and entire wings were in a pastel gray color. The stripe ahead of the cockpit was in cabin gray. Color accents on the aircraft were in red. In 1978, the aircraft with serial number 0443 was part of the VVLŠ SNP Košice aerobatic team. After the dissolution of Czechoslovakia, the aircraft served with the renowned Slovak aerobatic team Biele Albatrosy (White Albatrosses). In 2012, it underwent modernization to the CM version.

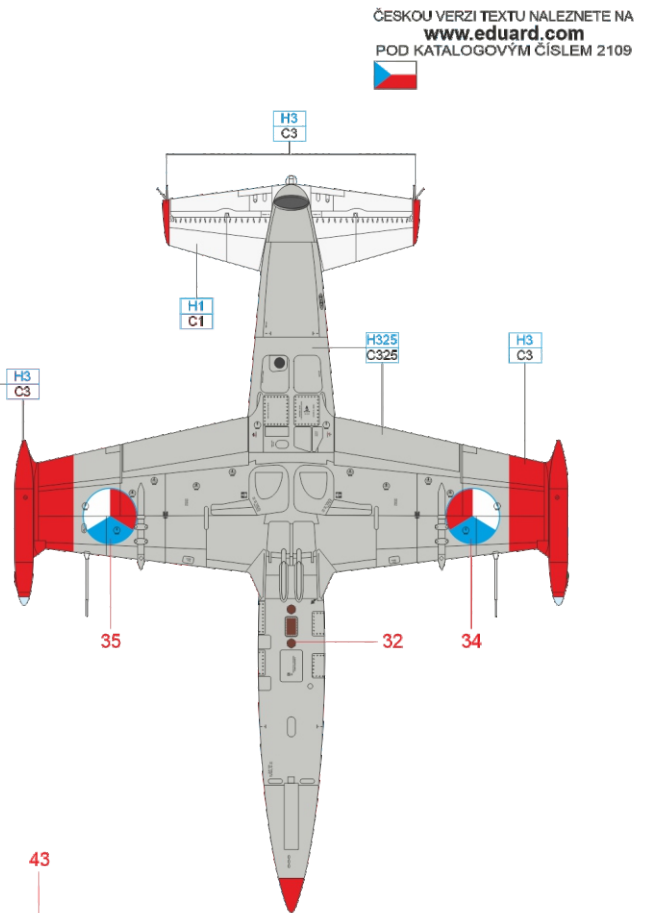
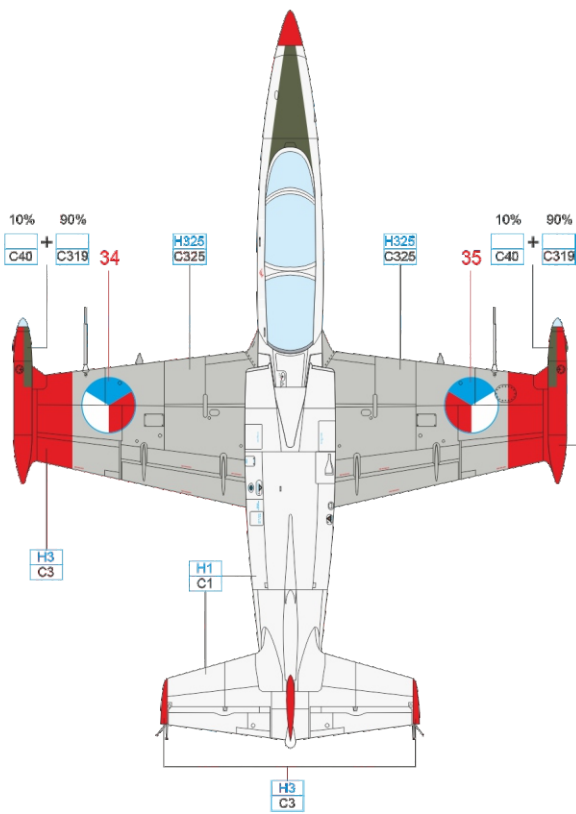
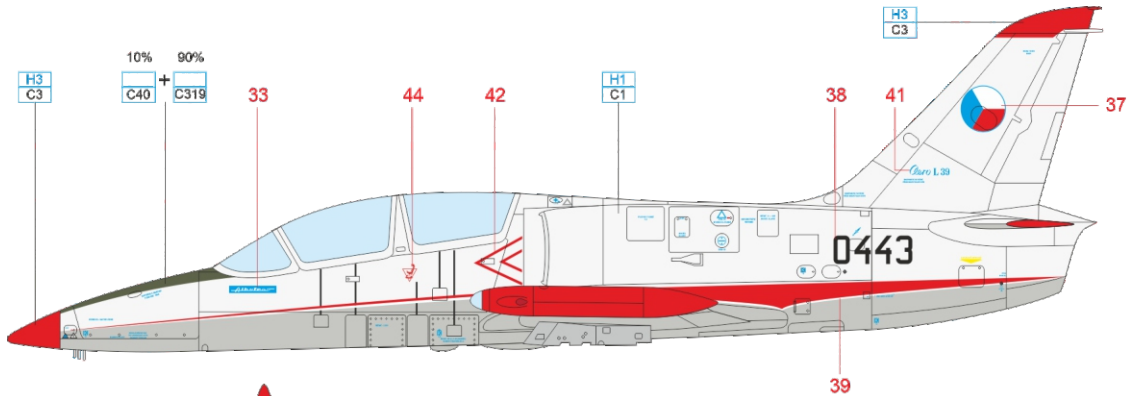

ČESKOU VERZI TEXTU NALEZNETE NA
www.eduard.com
 POD KATALOGOVÝM ČÍSLEM 2109

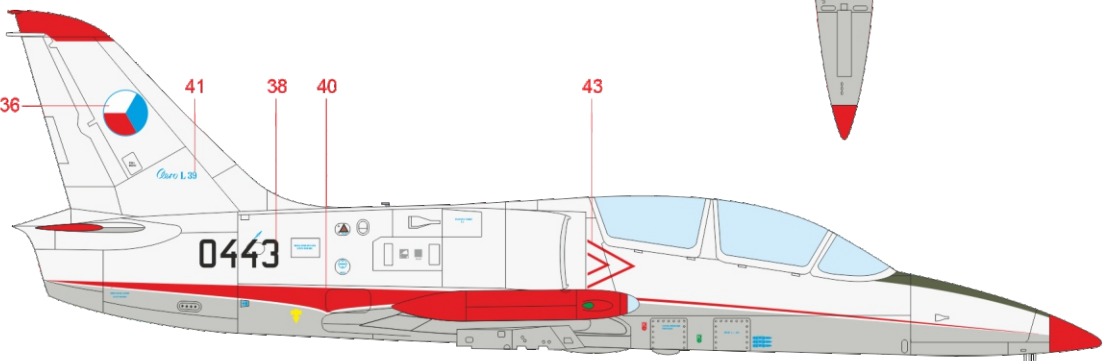

GRAY H325 C325 WHITE H1 C1 RED H3 C3 GRAY C40 GREEN C319

D L-39C, No. 0448, 1st Tactical Squadron, 4th Special Forces, Czech Air Force, Čáslav, Czech Republic, 2002

On April 1, 2004, a new organizational unit of LOM PRAHA s.p., the Center for Aviation Training Pardubice, was established. This unit leased 8 L-39C aircraft with serial numbers 0103, 0113, 0115, 0440, 0441, 0444, 0445, and 0448 from the Czech Armed Forces for the advanced training of military pilots. Since 2008, LOM PRAHA s.p. has had these aircraft under its asset management rights. The Center for Aviation Training LOM PRAHA has trained 90 proficient military pilots on L-39C aircraft for the Czech Republic Army since its establishment. Additionally, as per customer requirements, 15 foreign pilots have undergone the training. During the years 2015-2016, the R3 revision was completed. This revision essentially represented the highest level of maintenance in the entire technical lifespan of the modified L-39C aircraft at the Pardubice CLV. These Albatros aircraft can be easily recognized by their darker semi-gloss camouflage and, most notably, by their round "low-vis" national markings. The depicted aircraft with serial number 0448 still bears its original camouflage that it had while serving with the 1st Squadron of the 4 Tactical Air Base at Čáslav Air Base.

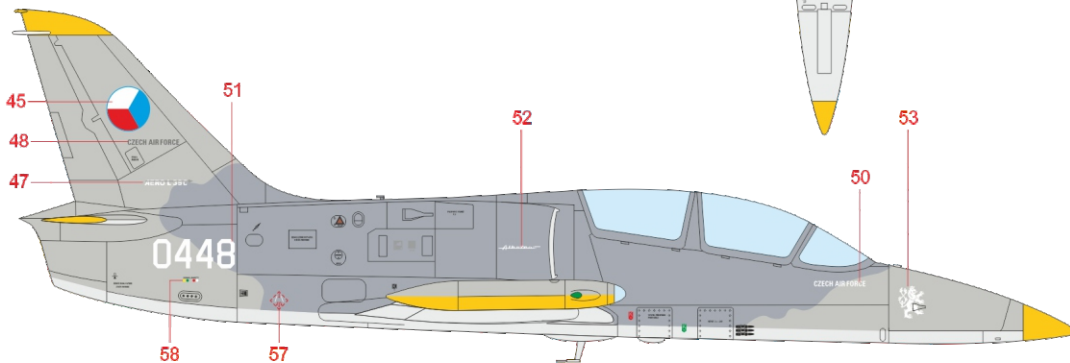
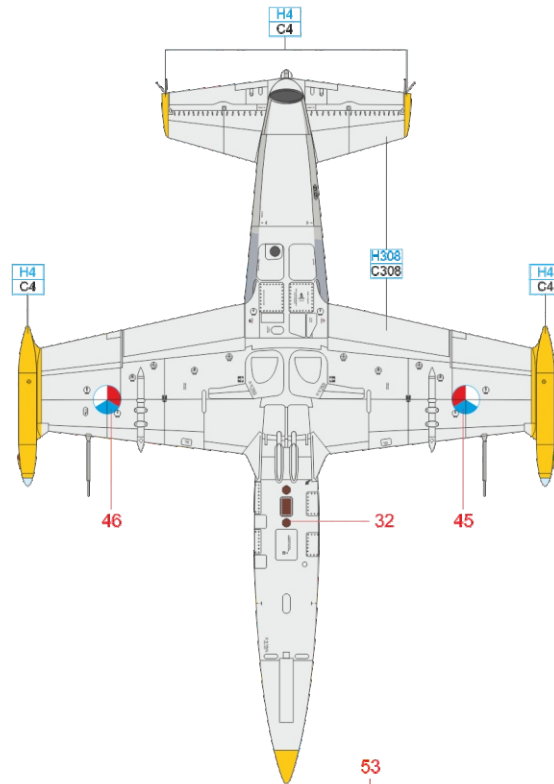
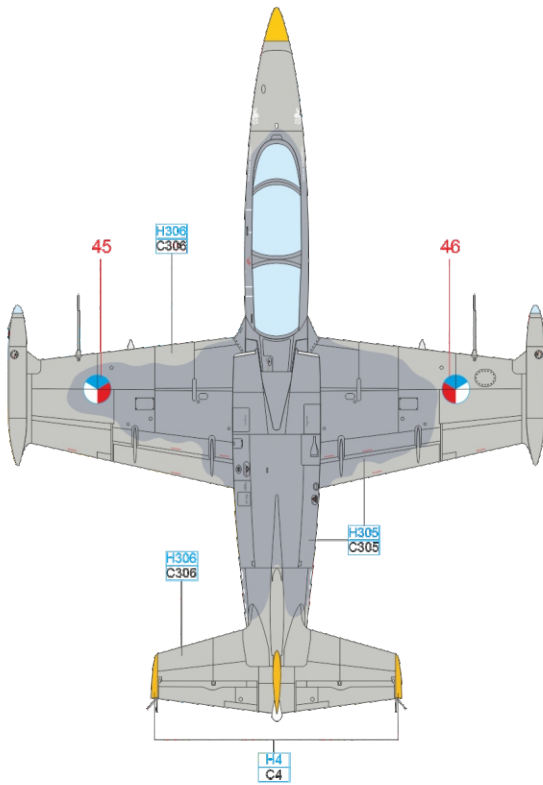
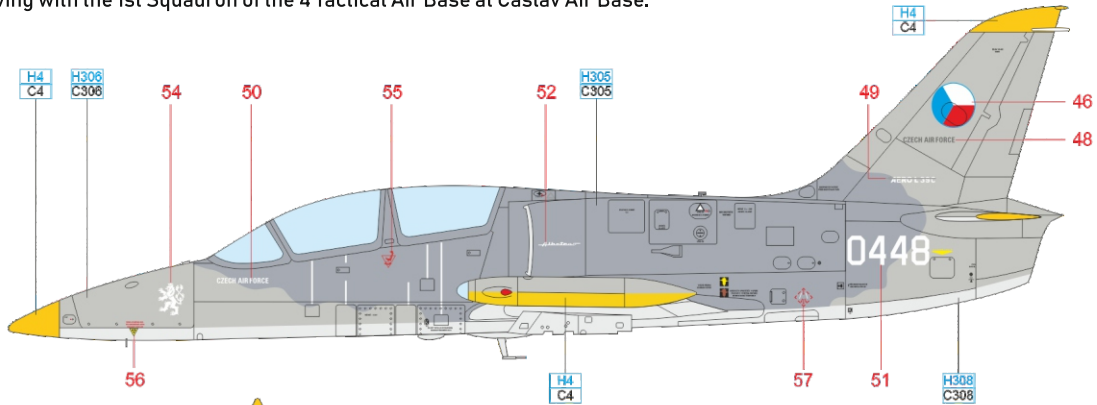

ČESKOU VERZI TEXTU NALEZNETE NA
www.eduard.com
 POD KATALOGOVÝM ČÍSLEM 2109



E L-39CM, s/n 915301, 2 Fighter Squadron, 31 Fighter Wing, Vzdušné síly Ozbrojených síl Slovenskej republiky, letište Sliač, Slovakia, 2012

The Albatros with serial number 5301 is a modernized CM variant operated by the 2 Fighter Squadron of the mixed wing (Zmiešane krídlo) based at Sliač. Before the modernization, it carried the number "0443" (s/n 530443) and was a well-known aircraft belonging to the Biele Albatrosy team. In 2012, the aircraft underwent a major overhaul during which it received a new gray camouflage. As part of the new scheme, the silhouette of the cockpit was included on the underside. After the modernization, it received a new serial number, 915301, and the national markings were applied to commemorate the 90th anniversary of the birth of Czechoslovak pilot S/Ldr Otto Smik. Currently, only three L-39CMs (5252, 5253, and 5301) are in operation; the remaining two were retired in 2011.

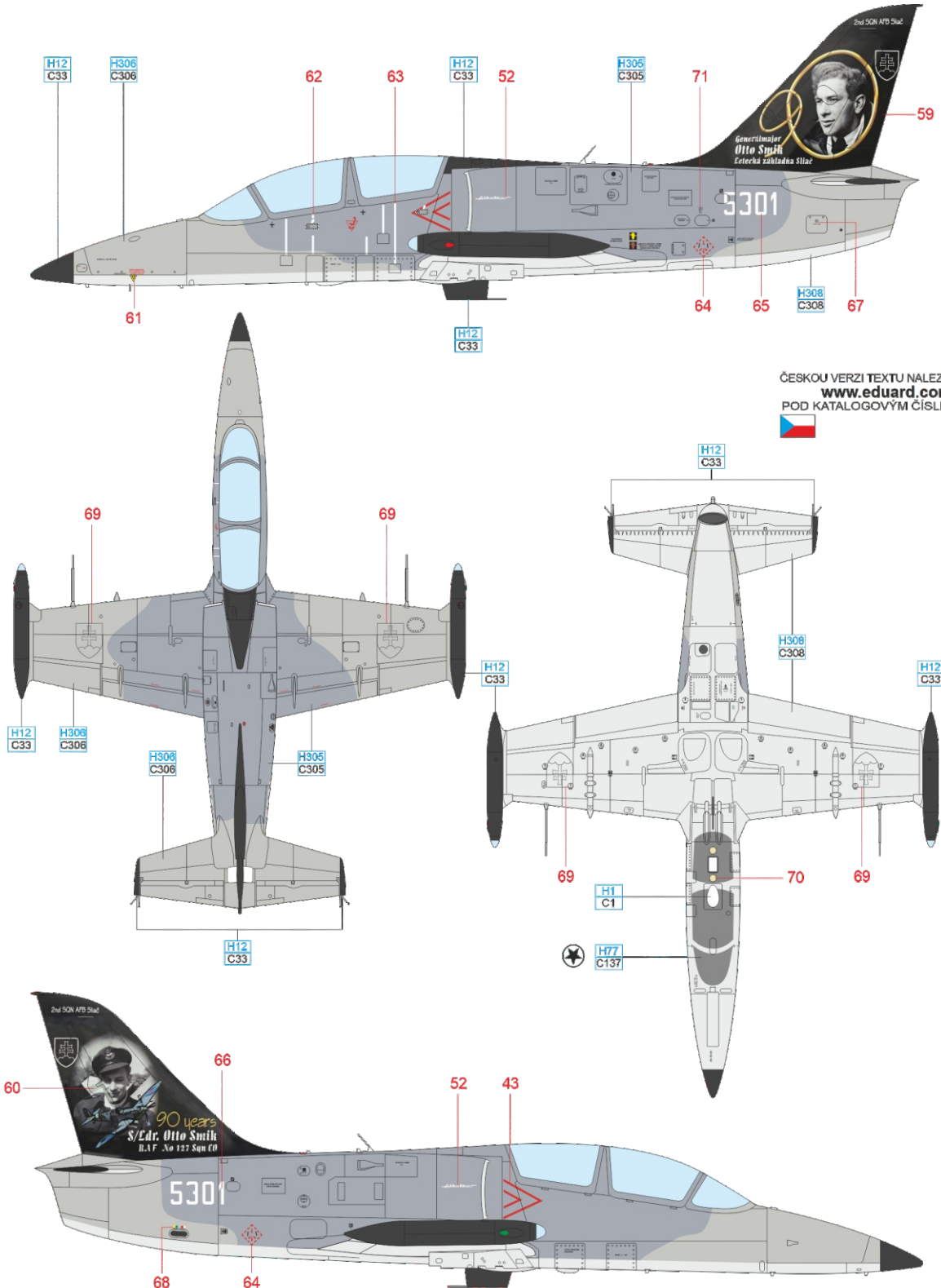

ČESKOU VERZI TEXTU NALEZNETE NA
www.eduard.com
 POD KATALOGOVÝM ČÍSLEM 2109



- GRAY H305 C305
- GRAY H306 C306
- GRAY H308 C308
- FLAT BLACK H12 C33
- WHITE H1 C1
- BLACK H77 C137

F L-39C, Iraq Air Force, Iraq, 1986

After the USSR, Iraq became the second foreign user of L-39 aircraft and the first customer to receive the ZO version. Iraqi L-39Cs were used in flight schools in Rashid and Tikrit.

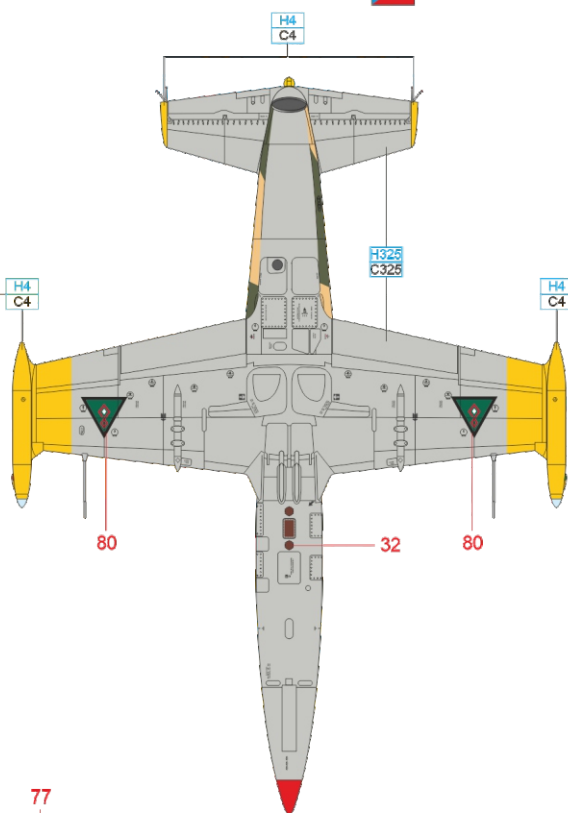
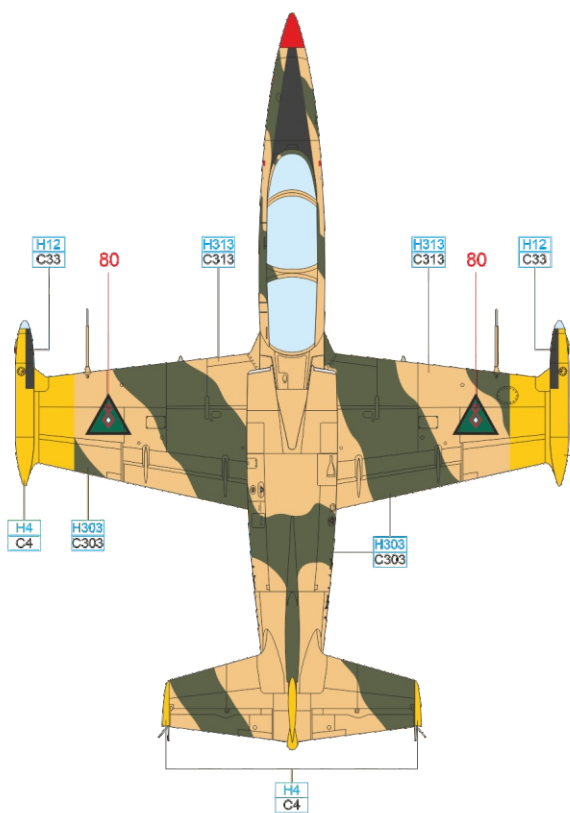
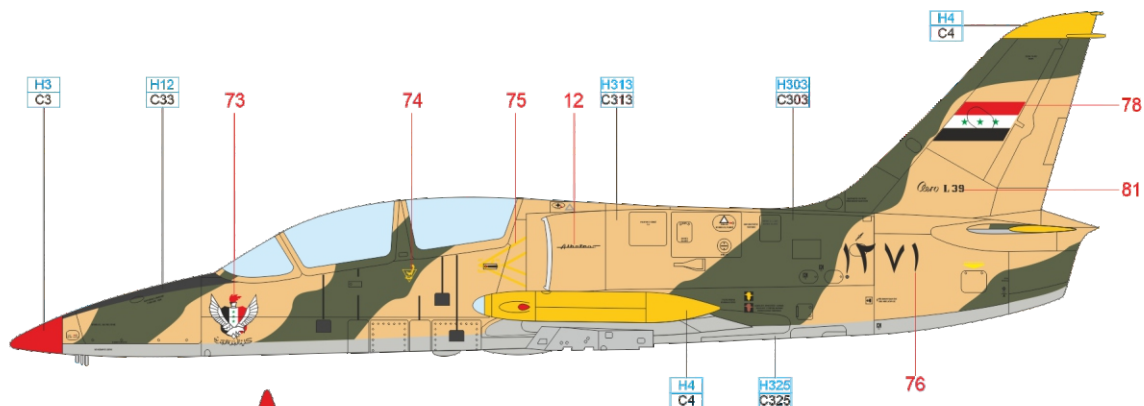

ČESKOU VERZI TEXTU NALEZNETE NA
www.eduard.com
 POD KATALOGOVÝM ČÍSLEM 2109

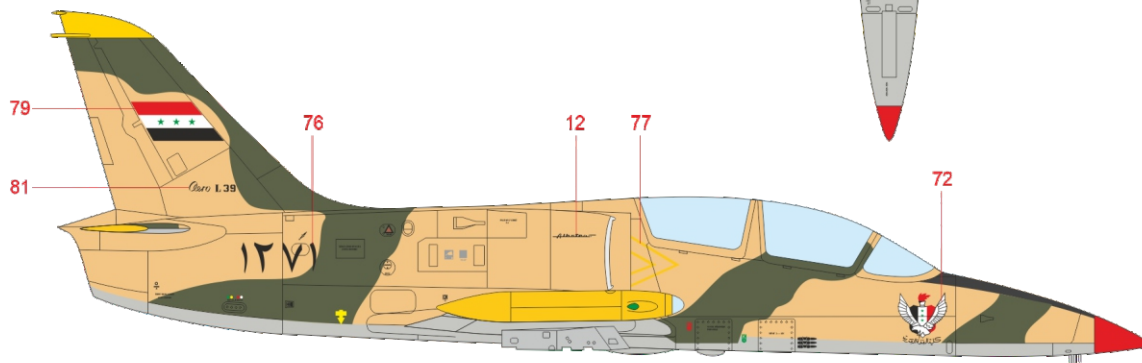

GREEN H303 C303 YELLOW H313 C313 GRAY H325 C325 YELLOW H4 C4 RED H3 C3 FLAT BLACK H12 C33

G L-39C, s/n 533229, No. 129, Ukrainian Air Force, Vasilkov AB, Ukraine, 2008

After the dissolution of the USSR in 1991, around 530 L-39 aircraft remained in Ukraine according to several sources. The poor financial situation of the entire military significantly reduced their number, and by 2005, fewer than 200 aircraft were airworthy. The rest of the Albatroses is in storage and available for potential sales.

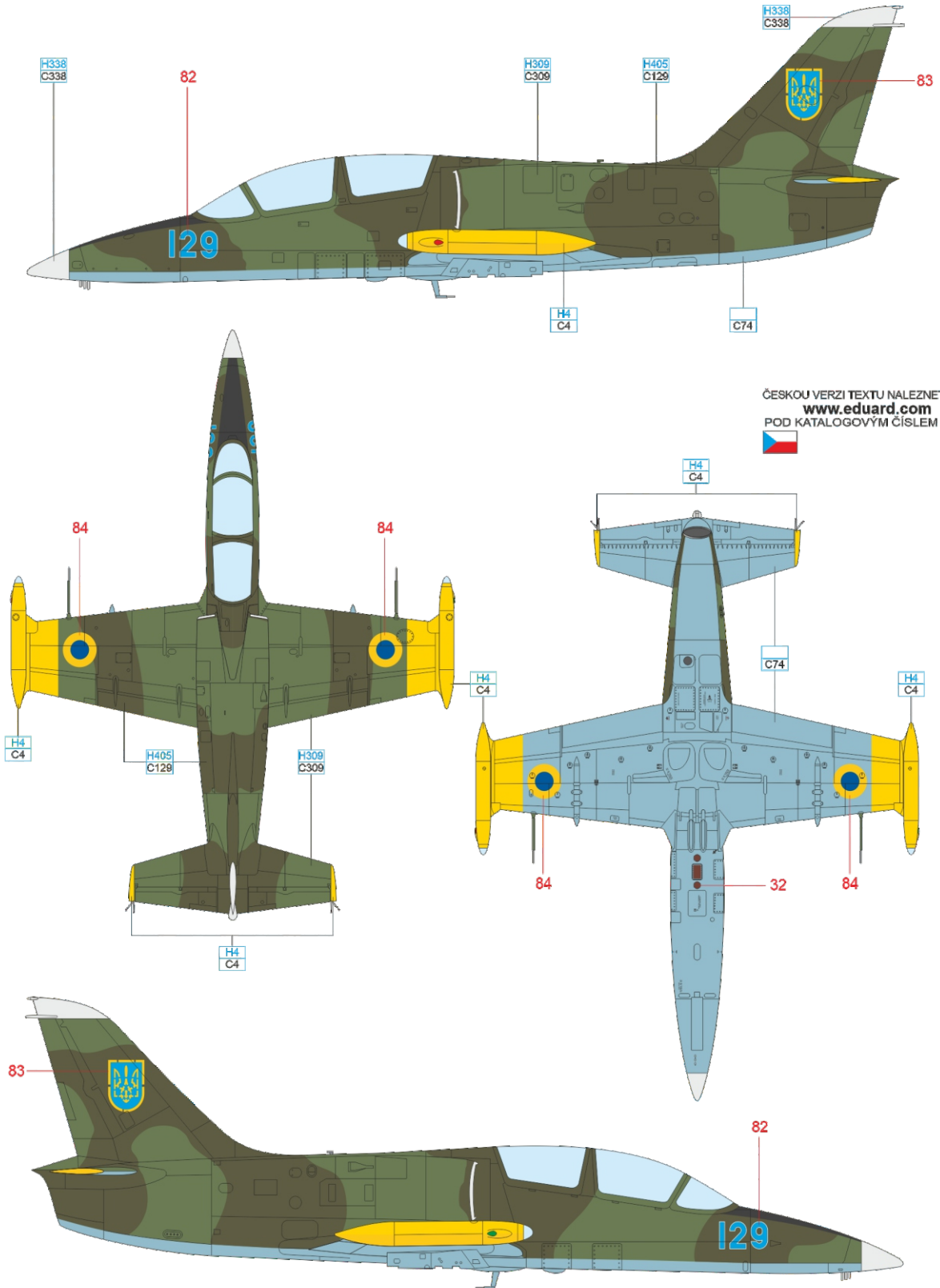

AIR BLUE	C74	OLIVE GREEN	H405 C129	GREEN	H309 C309	YELLOW	H4 C4	LIGHT GRAY	H338 C338
----------	-----	-------------	--------------	-------	--------------	--------	----------	------------	--------------

H L-39X-11, Aerosalon Paris, France, 1977

The prototype L-39X-11 (L-39Z0, OK-HXA, 3911, OK-190) was adorned with a white-gray-blue camouflage and shortly thereafter exhibited (equipped for Z0 version) at the Paris Air Show, where it earned the nickname "Pařížanka" (Parisienne) due to its non-standard coloring. Aircraft from Aero participated multiple times at the prestigious European airshow held at Le Bourget near Paris since 1977, but the first international presentation of the Albatros was certainly exceptional. In Paris, it was displayed with a photo container on the left inner pylon along with a symmetrical placement of a large (350-liter) drop tank, thus showcasing the aircraft's expanded usage - this time for aerial reconnaissance.

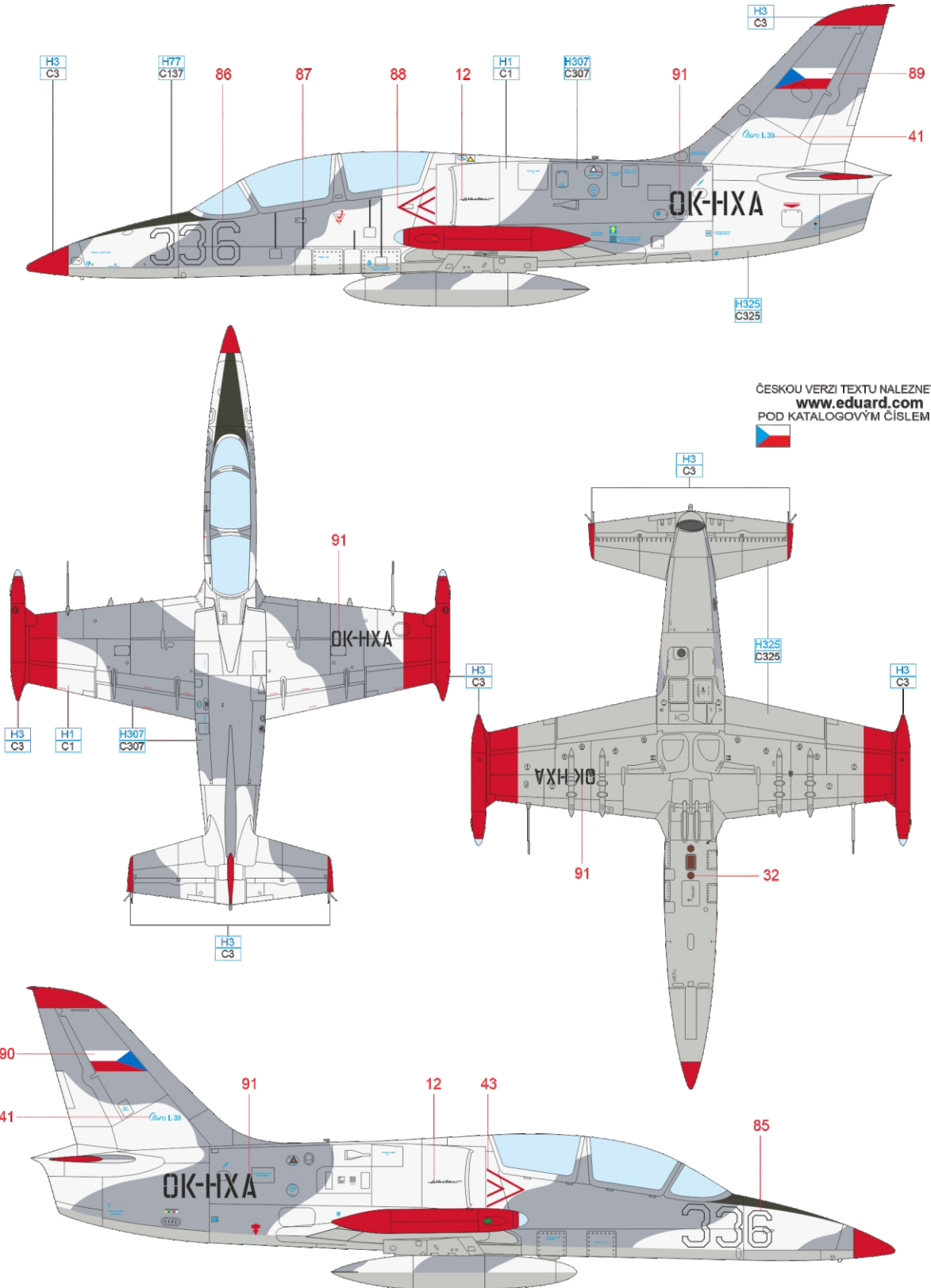

ČESKOU VERZI TEXTU NALEZNETE NA
www.eduard.com
 POD KATALOGOVÝM ČÍSLEM 2109



L-39ZA/ART, s/n 365504, Chiang Mai AB, Royal Thai Air Force, Thailand, 2014

The Royal Thai Air Force operated L-39ZA/ART aircraft at two airbases. The majority of them were stationed at Korat Air Base in the central part of Thailand, which serves as an RTAF showcase, hosting foreign delegations and conducting joint exercises with neighboring countries. The second base was Takhli, located about 200 km to the west, where the aircraft were used for operational flights. The L-39ZA aircraft were initially used by the 101st and 102nd Squadrons in Korat, then by the 401st Squadron in Thakli, and the 411th Squadron in Chiang Mai. The RTAF received a total of 40 L-39 aircraft by 1994, with about 5 lost in accidents. On the occasion of anniversaries, some aircraft were presented in special liveries featuring emblems of all four squadrons. On March 31, 2021, the Royal Thai Air Force held the ceremony on the occasion of the Aero L-39ZA/ART retirement from the active duty. The last operator was the 411th Squadron, 41st Wing, based in Chiang Mai.

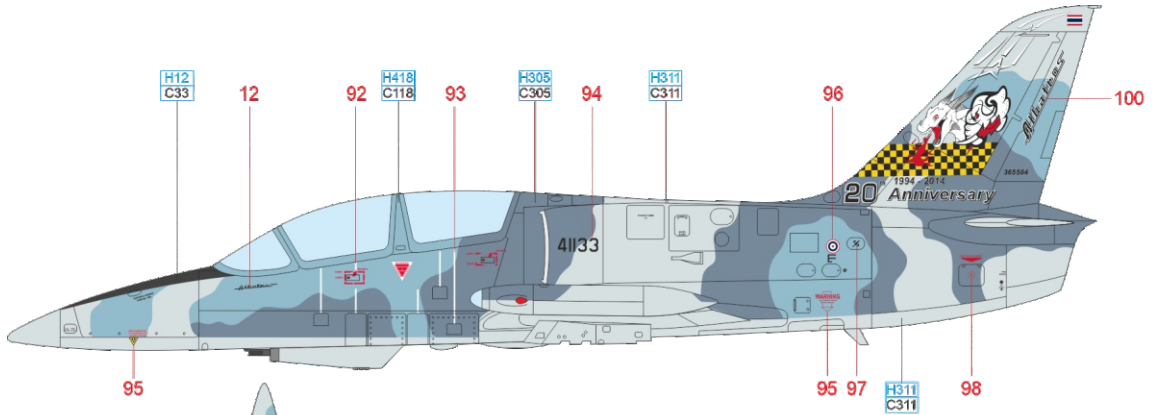

ČESKOU VERZI TEXTU NALEZNETE NA
www.eduard.com
 POD KATALOGOVÝM ČÍSLEM 2109

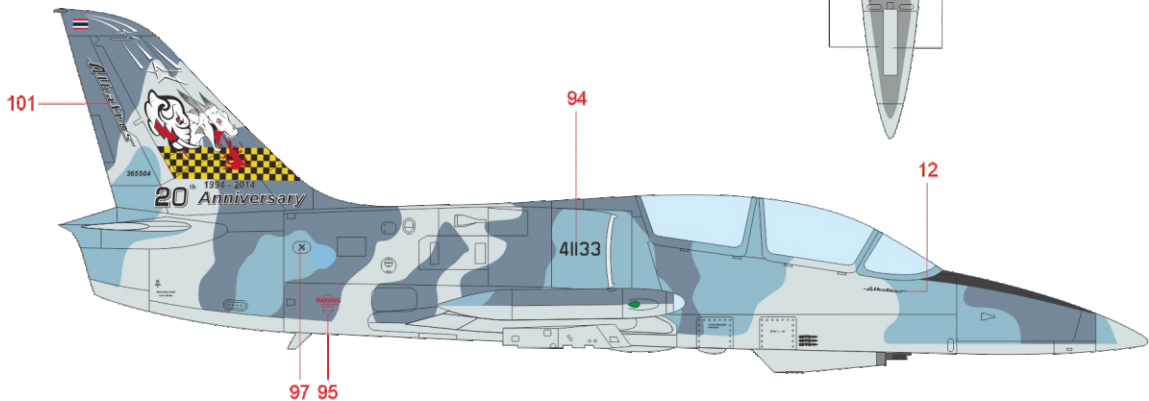
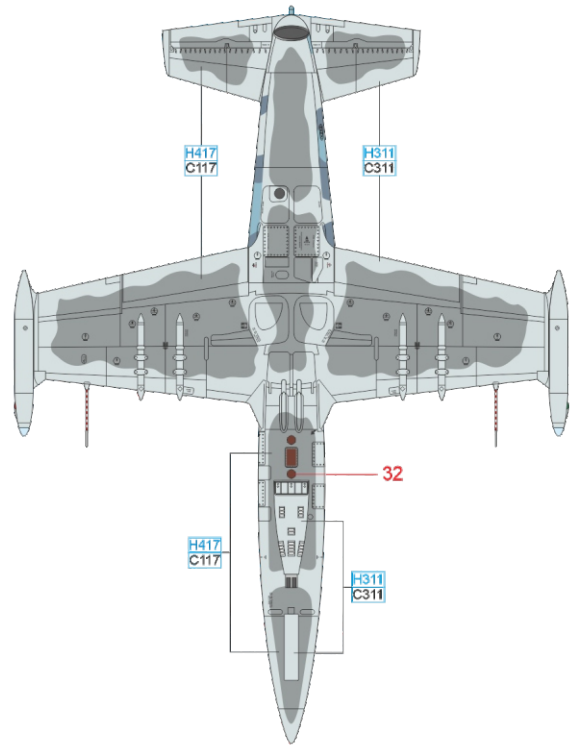
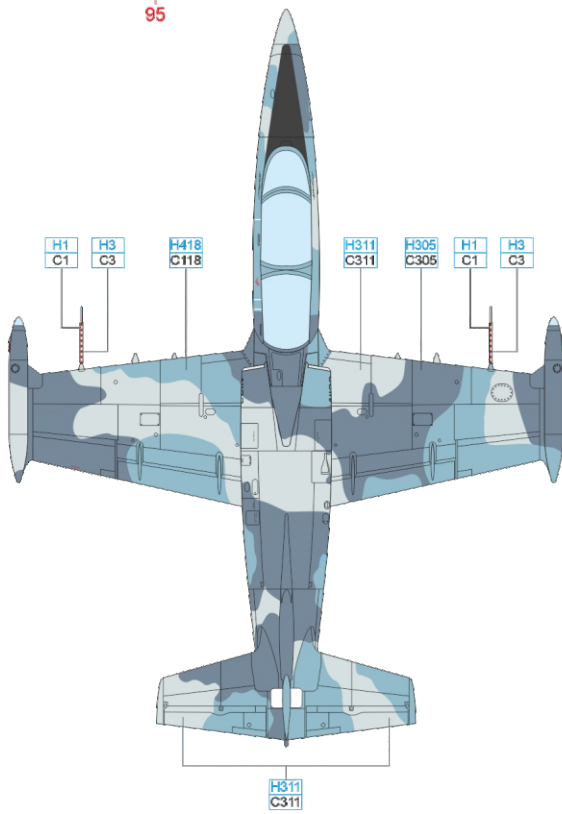

GRAY	H311 C311	BLUE GRAY	H305 C305	LIGHT BLUE	H418 C118	GRAY	H417 C117	FLAT BLACK	H12 C33	WHITE	H1 C1	RED	H3 C3
------	--------------	-----------	--------------	------------	--------------	------	--------------	------------	------------	-------	----------	-----	----------

Blue stencils - MARKINGS C, H ONLY

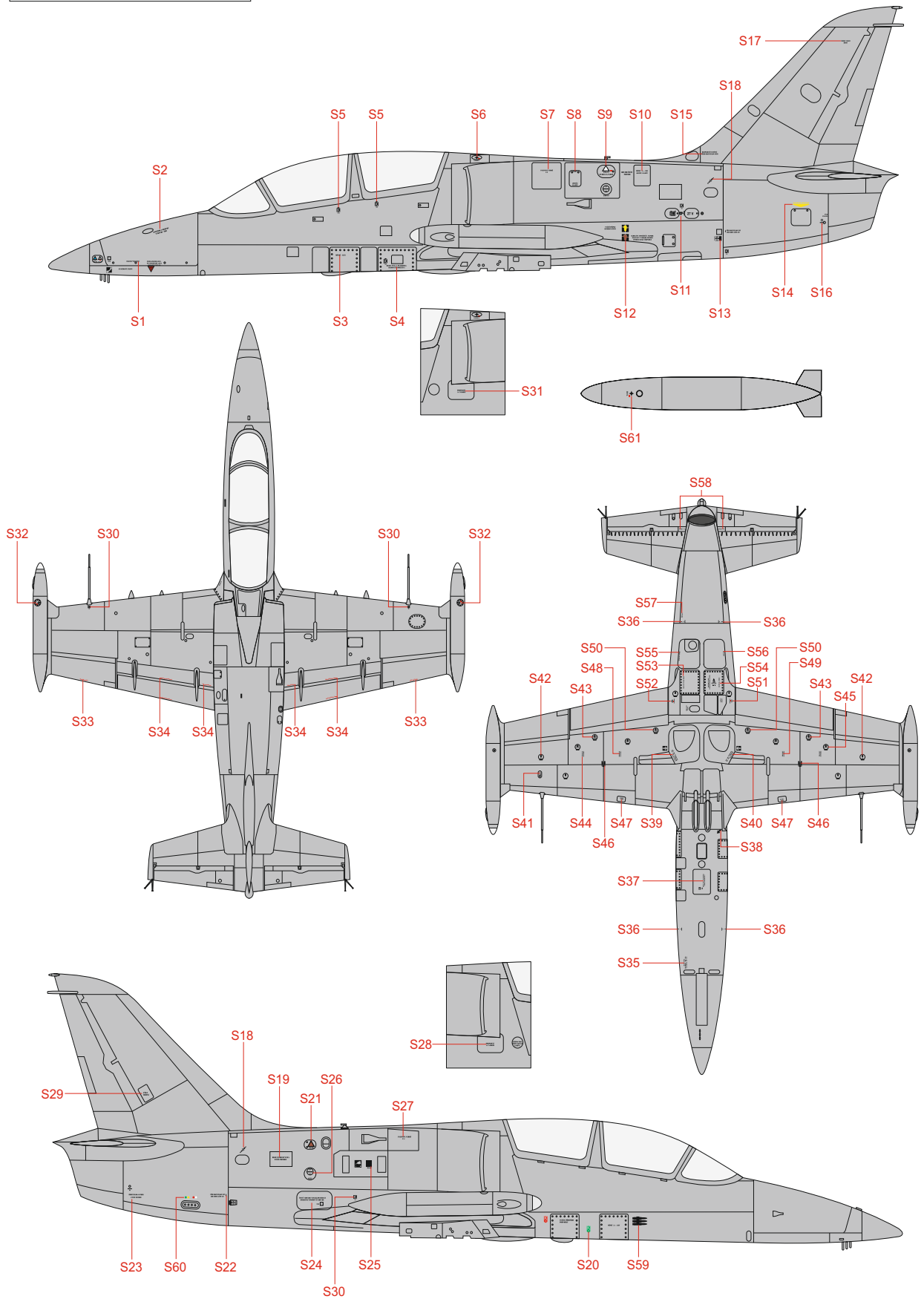

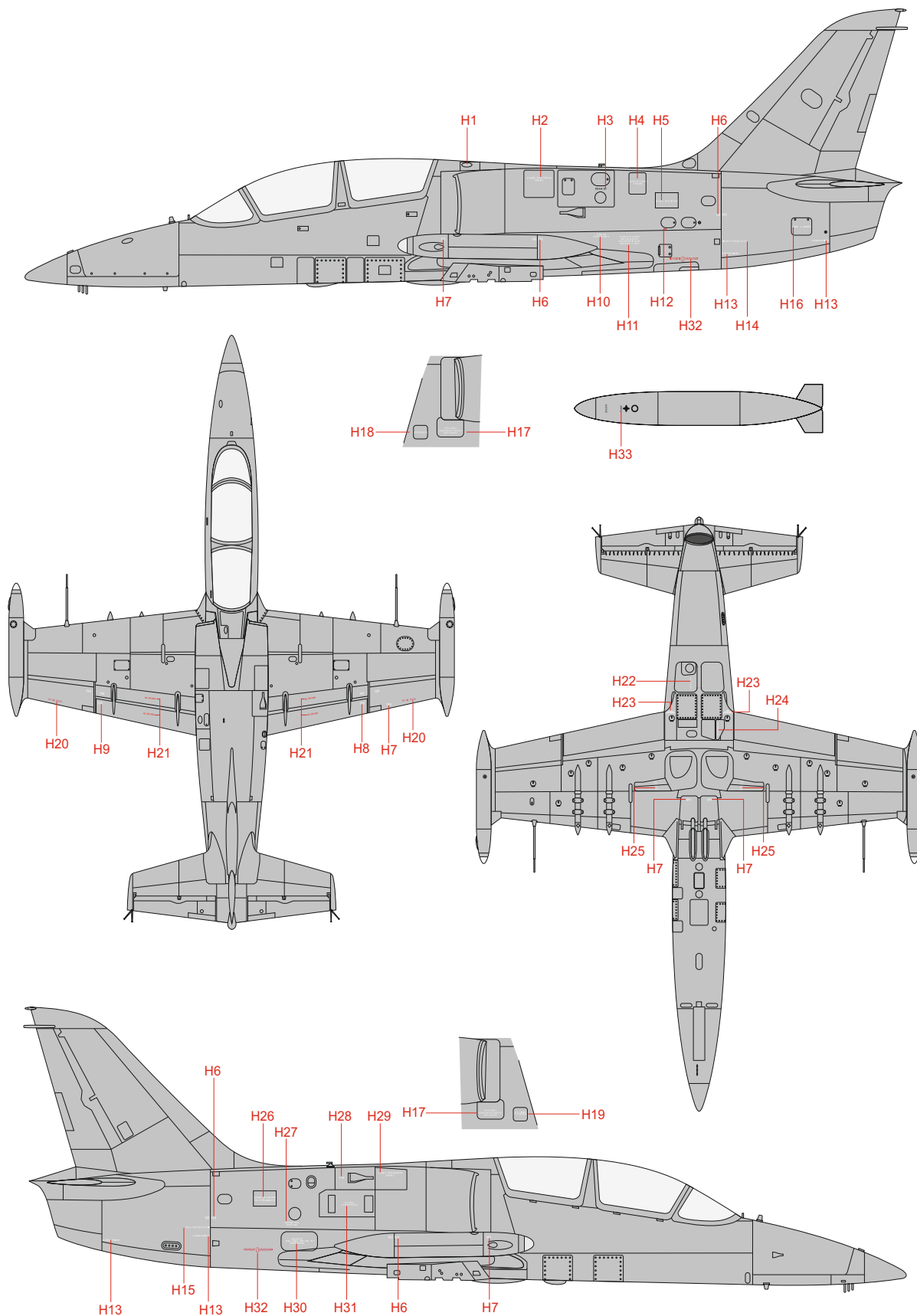

Complete your collection of Czechoslovak aircraft with ...

7055



70144



available at www.eduard.com

70142



70151



7469



70153



7461

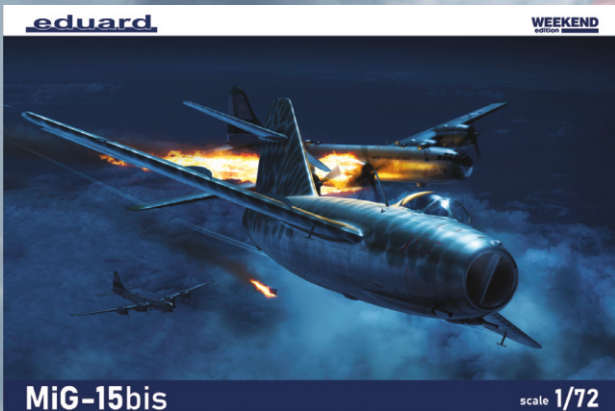

70152

