

eduard

LIMITED  
EDITION



*Spitfire Story:*  
*The Sweeps*

INSTRUCTION SHEET

1/72

2154-NAV 1

ATTENTION

UPOZORNĚNÍ

ACHTUNG

ATTENTION

注意



Carefully read instruction sheet before assembling. When you use glue or paint, do not use near open flame and use in well ventilated room. Keep out of reach of small children. Children must not be allowed to suck any part, or pull vinyl bag over the head.



Před započítím stavby si pečlivě prostudujte stavební návod. Při používání barev a lepidel pracujte v dobře větrané místnosti. Lepidla ani barvy nepoužívejte v blízkosti otevřeného ohně. Model není určen malým dětem, mohlo by dojít k požití drobných dílů.

INSTRUCTION SIGNS \* INSTR. SYMBOLS \* INSTRUKTION SINNBILDEN \* SYMBOLES \* 記号の説明



OPTIONAL  
VOLBA



BEND  
OHNOUT



SAND  
BROUSIT



OPEN HOLE  
VYVRTAT OTVOR



SYMETRICAL ASSEMBLY  
SYMETRICKÁ MONTÁŽ



REMOVE  
ODRÍZNOUT



REVERSE SIDE  
OTOČIT



APPLY EDUARD MASK  
AND PAINT  
POUŽIT EDUARD MASK  
NABARVIT

PLEASE CHECK THE LATEST VERSION OF THE INSTRUCTIONS ON [www.eduard.com](http://www.eduard.com)

PARTS

DÍLY

TEILE

PIÈCES

部品

A> 2 pcs.

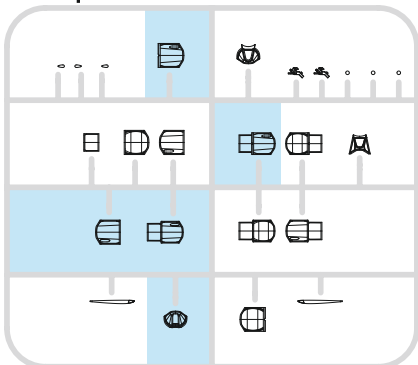

M> 2 pcs. PLASTIC PARTS

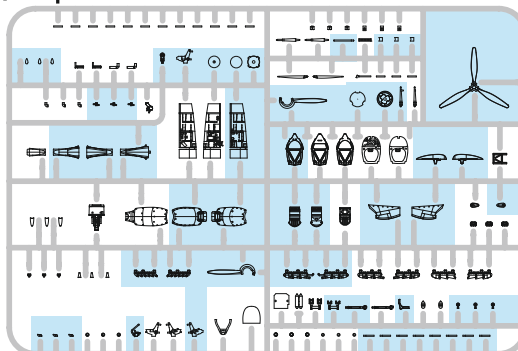

eduard  
MASK

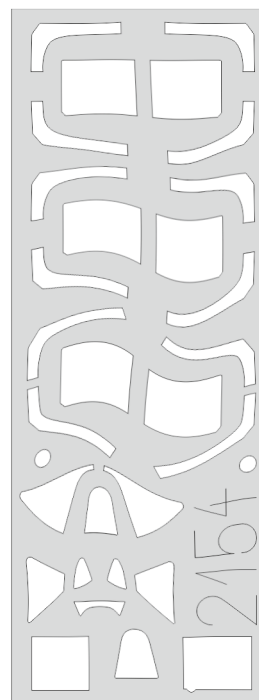

N> 2 pcs.

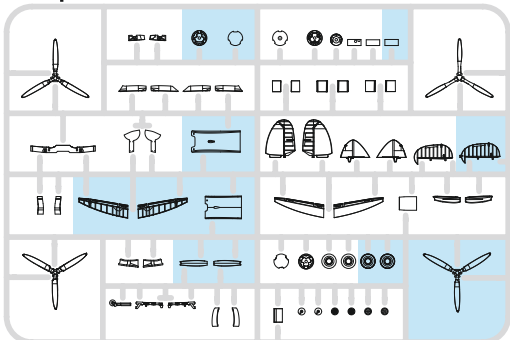

E,G,L>

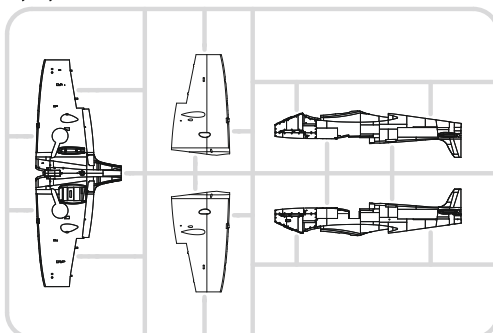

E,G,K>

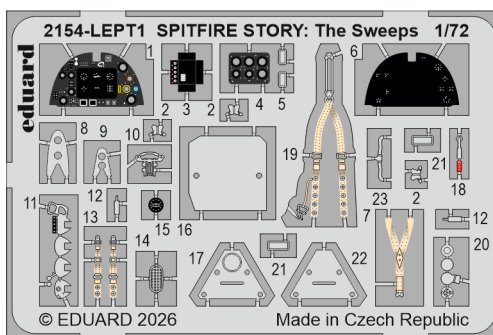
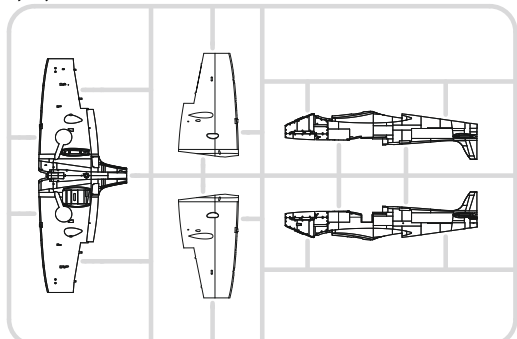

PE - PHOTO ETCHED DETAIL PARTS  
2 pcs.

-Parts not for use. -Teile werden nicht verwendet. -Pièces à ne pas utiliser. -Tyto díly nepoužívejte při stavbě. - 使用しない部品

COLOURS

BARVY

FARBEN

PEINTURE

色

GSI Creos (GUNZE)		
AQUEOUS	Mr.COLOR	
H3	C3	RED
H4	C4	YELLOW
H11	C62	FLAT WHITE
H12	C33	FLAT BLACK
H32	C40	FIELD GRAY
H33	C81	RUSSET
H51	C11	LIGHT GULL GRAY
H74	C368	SKY
H76	C61	BURNT IRON
H77	C137	TIRE BLACK
H78	C38	OLIVE GREEN
H84	C42	MAHOGANY
H90	C47	CLEAR RED

GSI Creos (GUNZE)		
AQUEOUS	Mr.COLOR	
H94	C138	CLEAR GREEN
H326	C326	BLUE
H327	C327	RED
H330	C361	DARK GREEN
H333	C333	EXTRA DARK SEAGRAY
H335	C363	MEDIUM SEAGRAY
	C362	OCEAN GRAY
	C364	AIRCRAFT GRAY-GREEN
	C370	AZURE BLUE
Mr.COLOR SUPER METALLIC		
	SM201	SUPER FINE SILVER
	SM212	ALUMINIUM

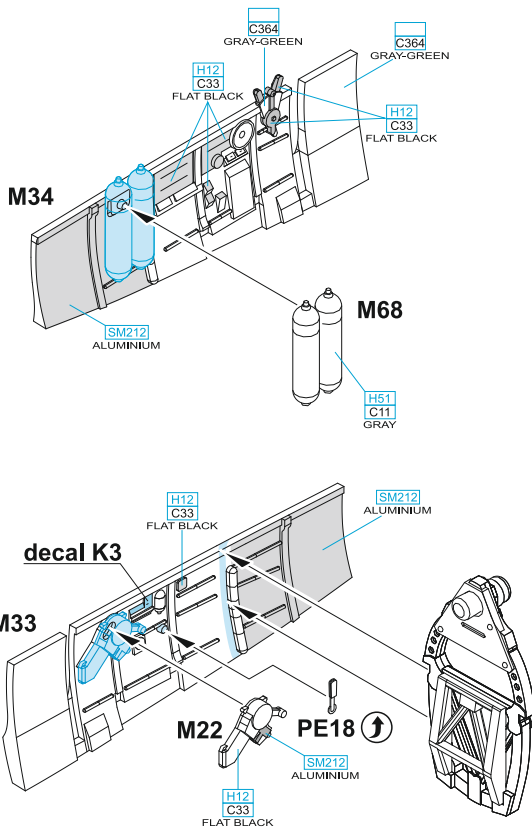

**M85 - MARKINGS A, B, C, D, F, G ONLY**

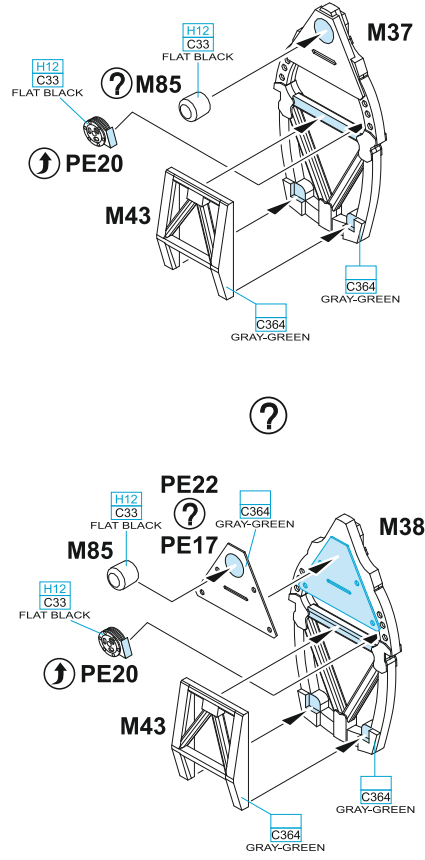

**A**

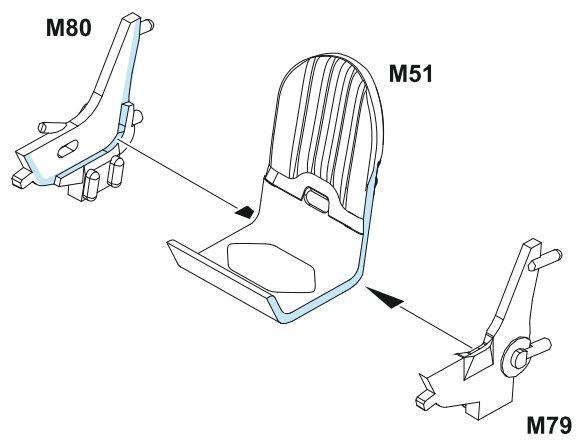

**PE17, M85 - MARKINGS A, B, C, D, F, G**  
**PE22 - MARKINGS E, H, I, J, K**

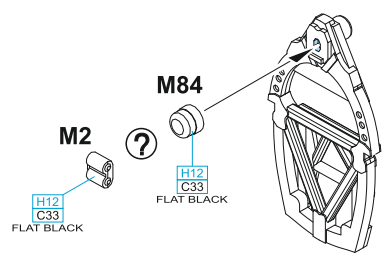

**M84 - MARKINGS A, B, F**  
**M2 - MARKINGS C, D, E, G, H, I, J, K**

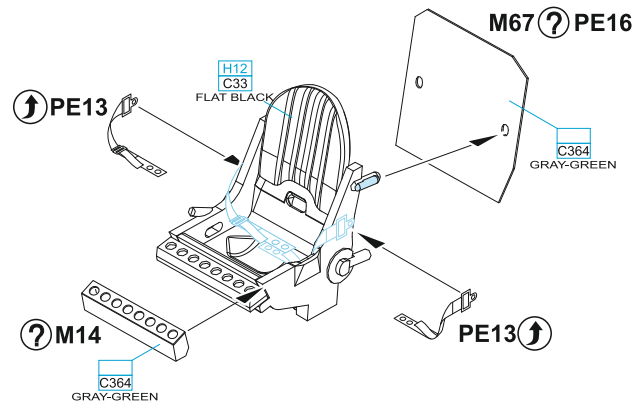

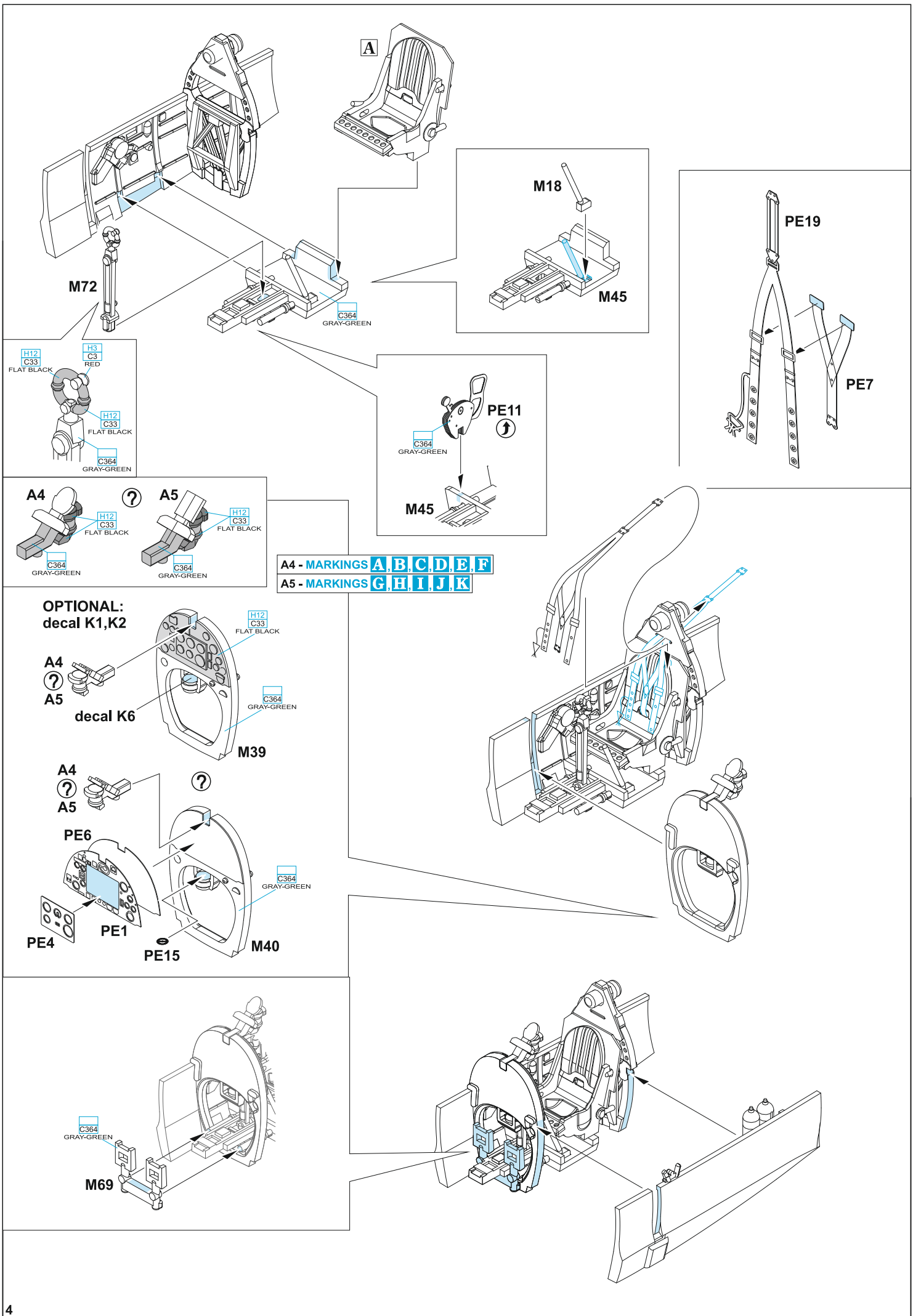

**A**

**M18**

**PE19**

**M72**

**M45**

**PE7**

**PE11**

**C364**  
GRAY-GREEN

**M45**

**H12**  
**C33**  
FLAT BLACK

**H3**  
**C3**  
RED

**H12**  
**C33**  
FLAT BLACK

**C364**  
GRAY-GREEN

**A4** ?

**A5** ?

**H12**  
**C33**  
FLAT BLACK

**C364**  
GRAY-GREEN

**C364**  
GRAY-GREEN

**A4 - MARKINGS A, B, C, D, E, F**

**A5 - MARKINGS G, H, I, J, K**

**OPTIONAL:**  
decals K1, K2

**A4** ?

**A5** ?

**decals K1, K2**

**decals K6**

**H12**  
**C33**  
FLAT BLACK

**C364**  
GRAY-GREEN

**M39**

**A4** ?

**A5** ?

**PE6**

**PE4**

**PE1**

**PE15**

**M40**

**C364**  
GRAY-GREEN

**C364**  
GRAY-GREEN

**M69**

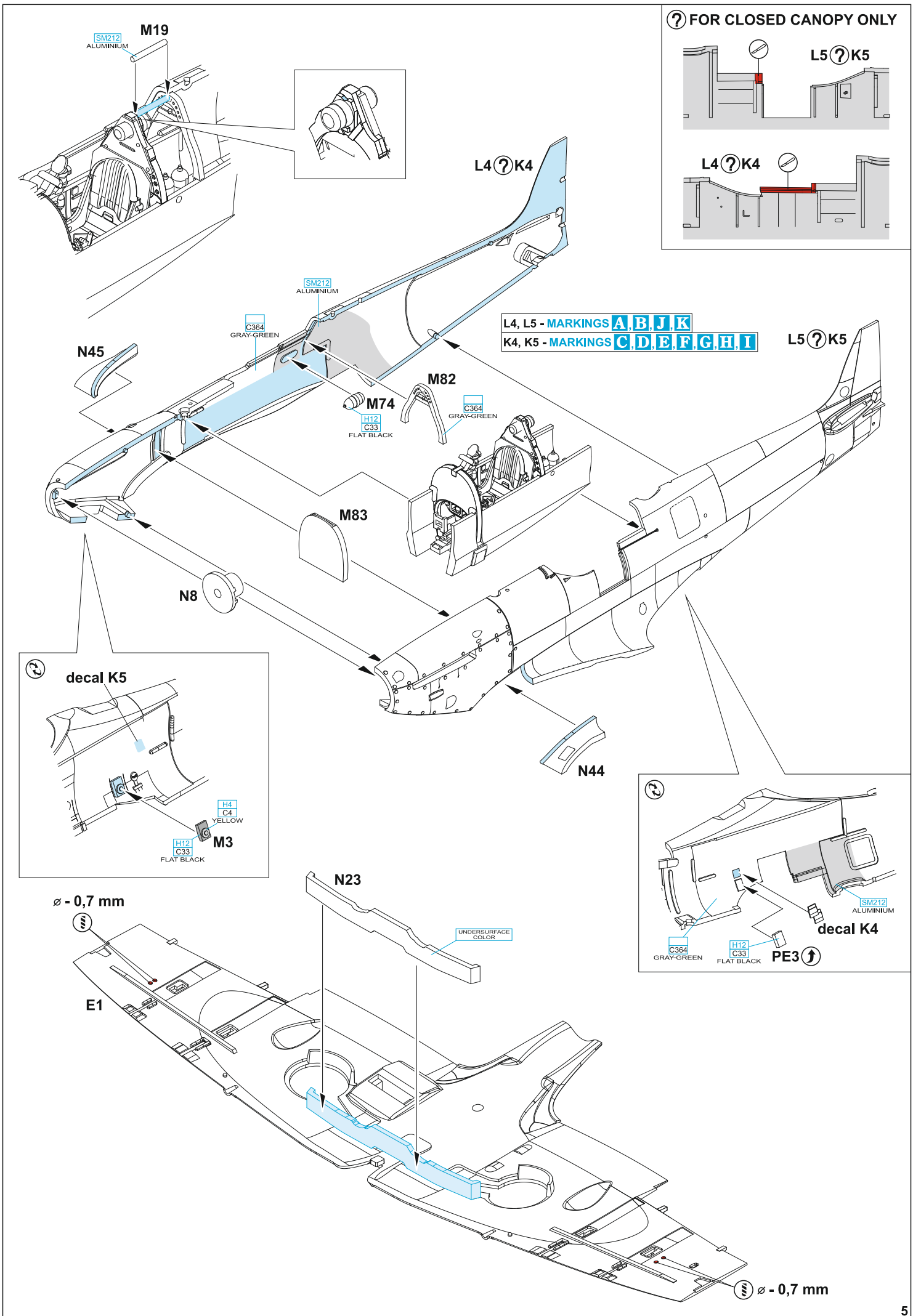

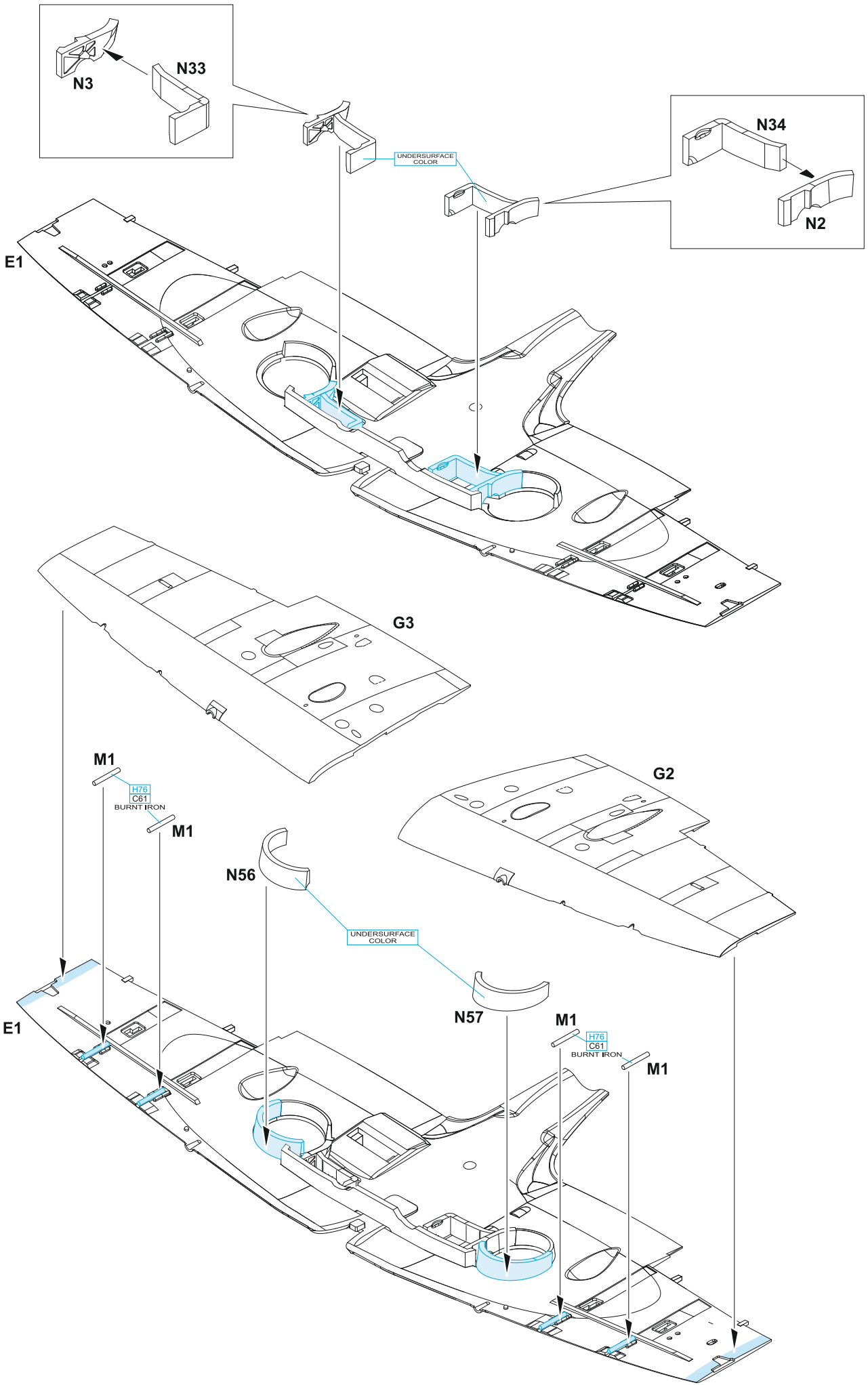

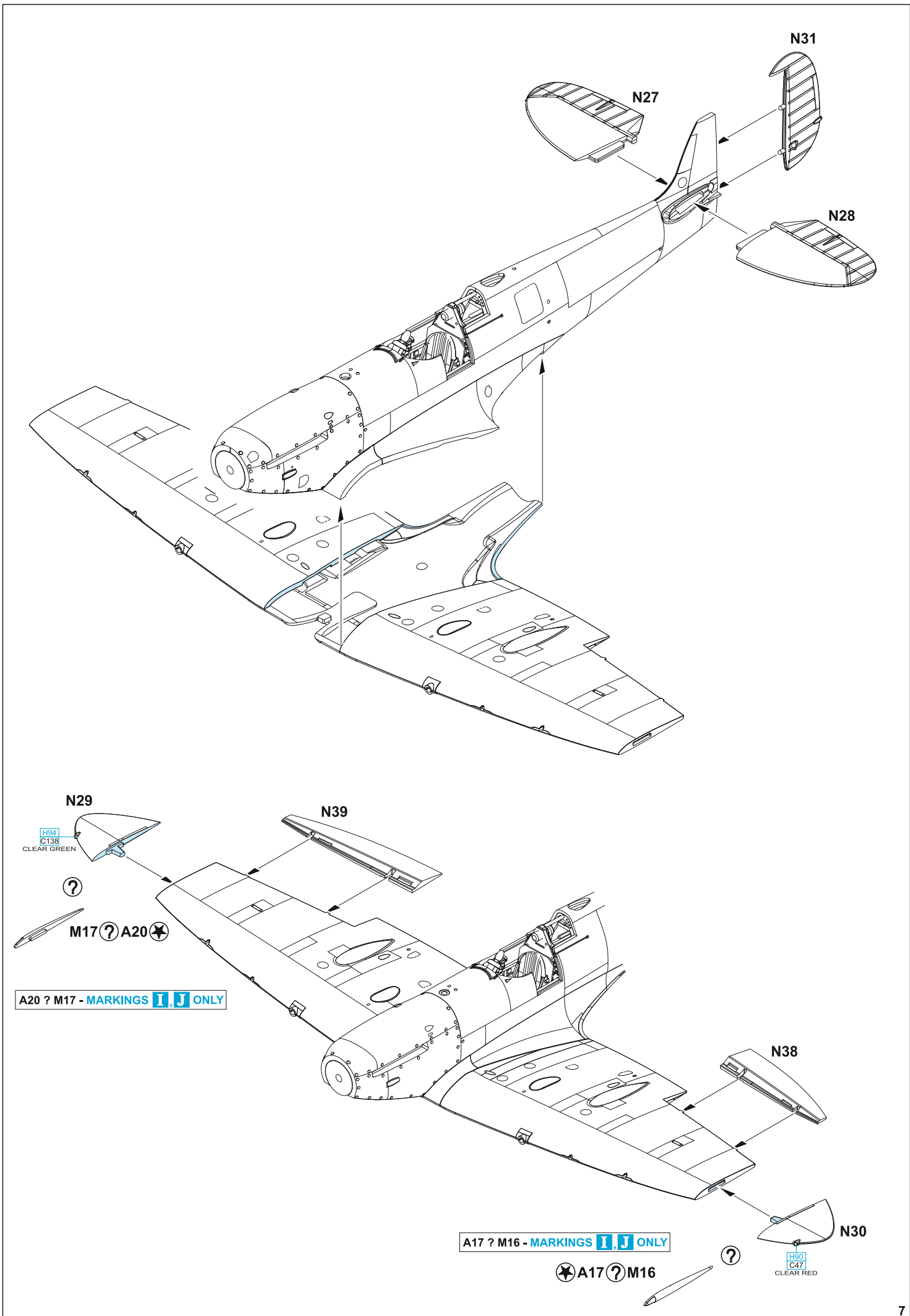

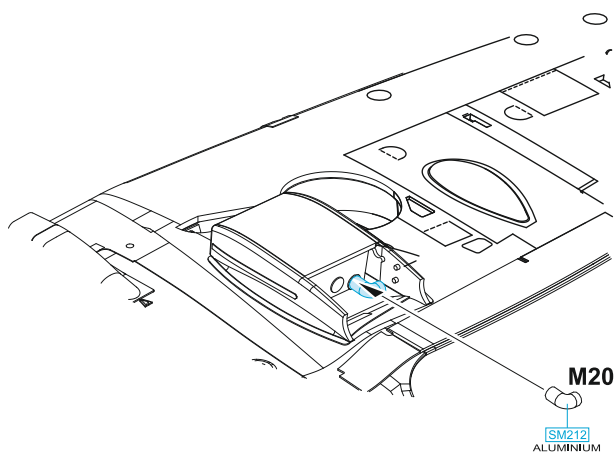
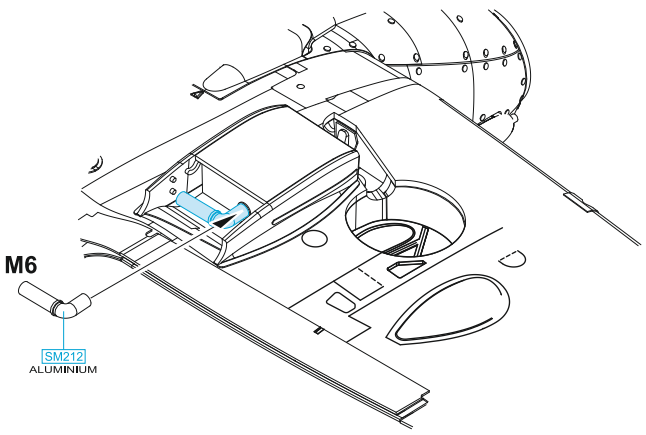
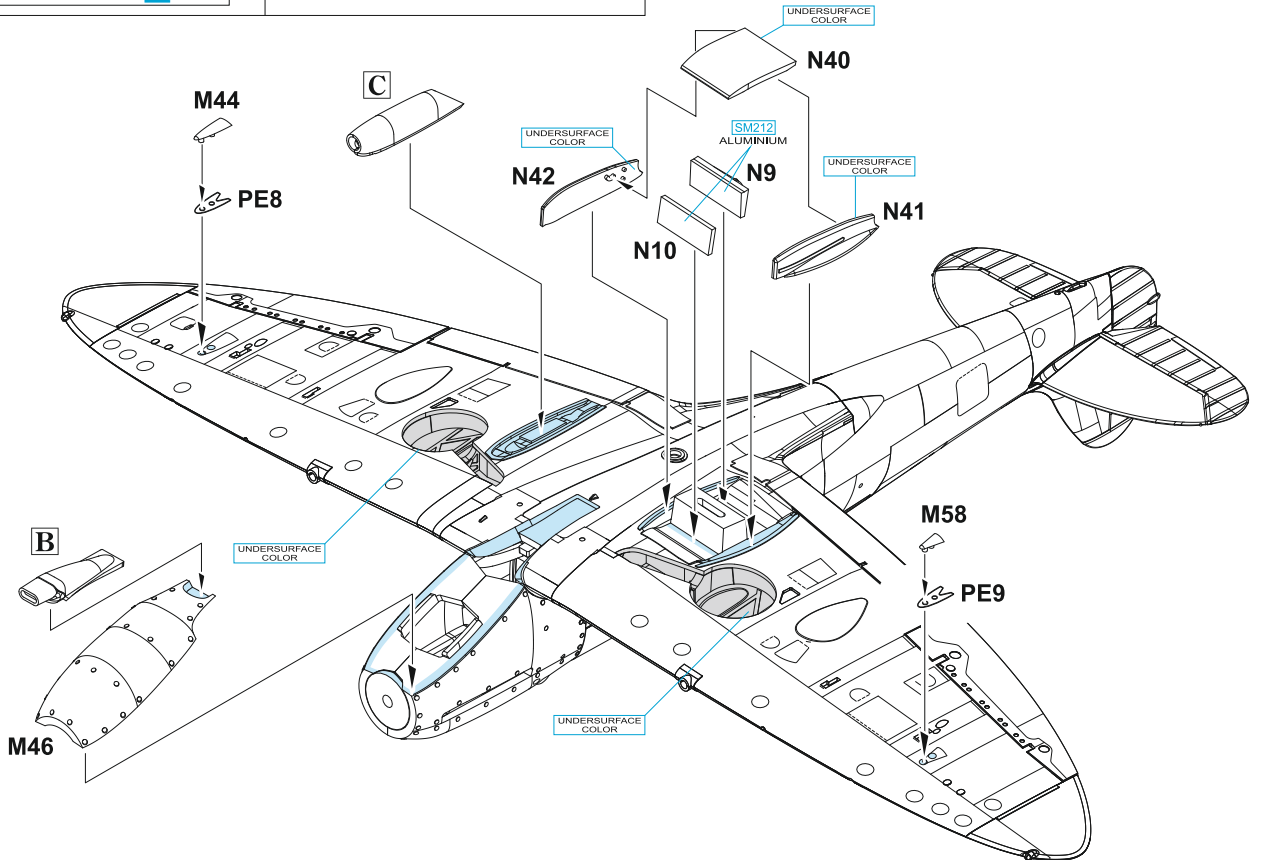
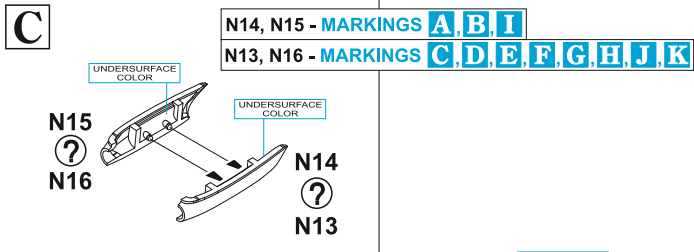
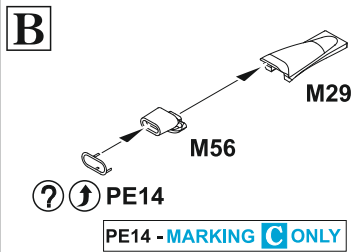

**CLOSED**

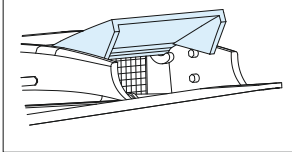
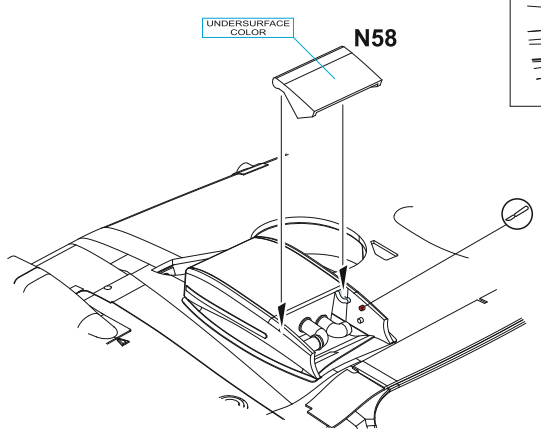

**OPEN**

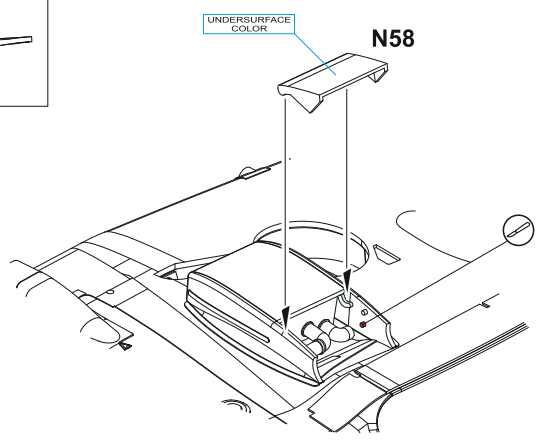

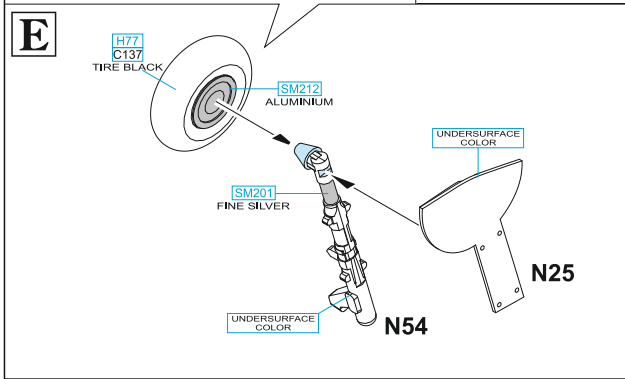
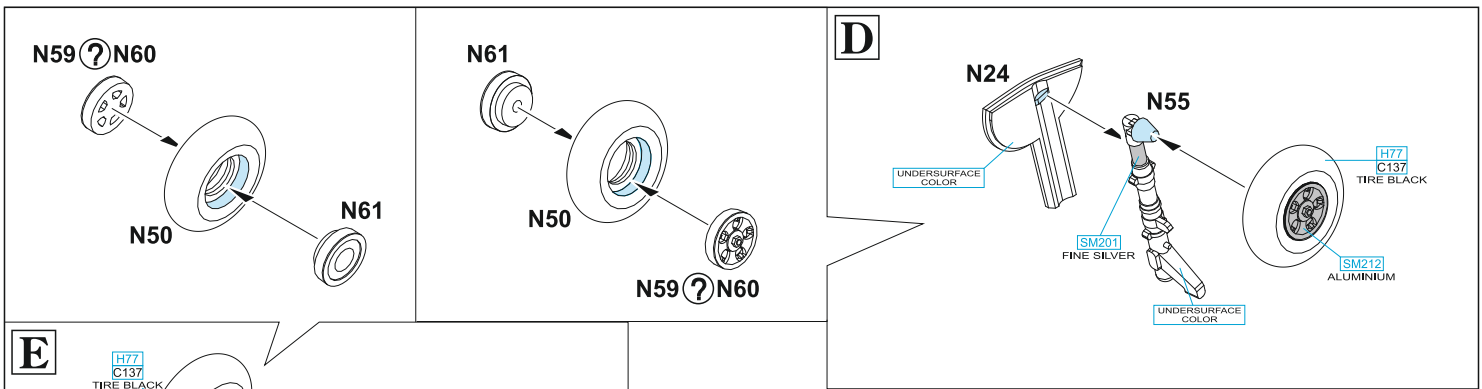

**N60 - MARKINGS A, B, E, F, G, H, I, J**  
**N59 - MARKINGS C, D, K**

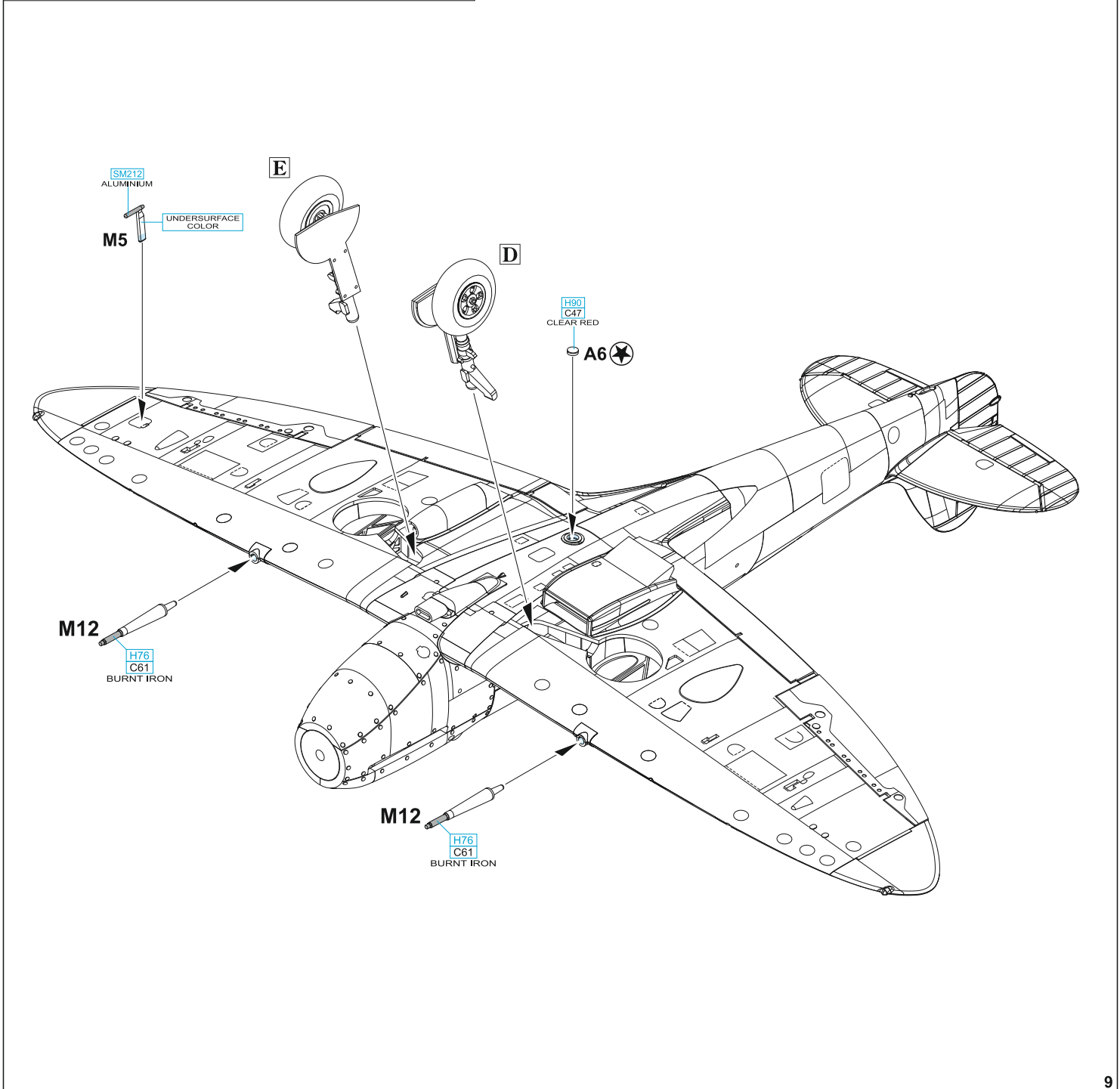

H77  
C137  
TIRE BLACK

N53

SM212  
ALUMINIUM

SM212  
ALUMINIUM

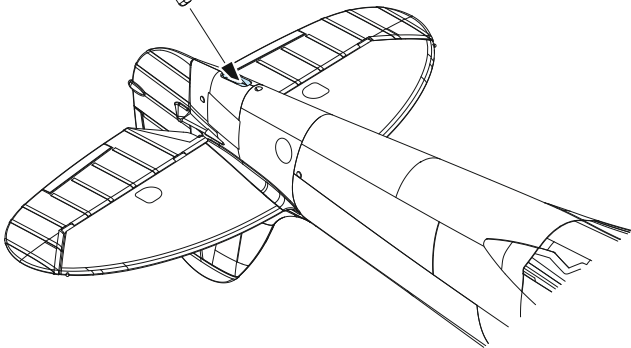

**F**

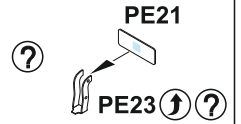
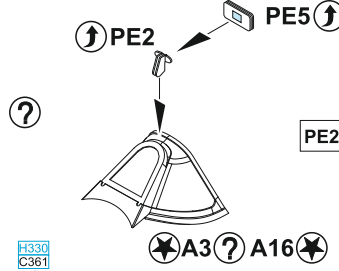
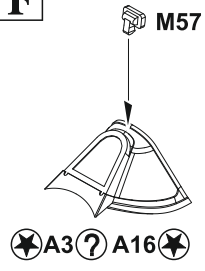

PE21, PE23 - MARKING **G** ONLY

H330  
C361  
DARK GREEN

SM201  
FINE SILVER

A16 - MARKINGS **A, B, J, K**

A3 - MARKINGS **C, D, E, F, G, H, I**

**G**

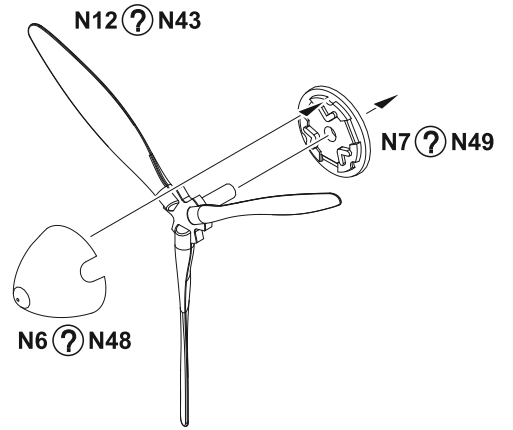

N6, N7, N12 - MARKINGS **A, B, J, K**

N43, N48, N49 - MARKINGS **C, D, E, F, G, H, I**

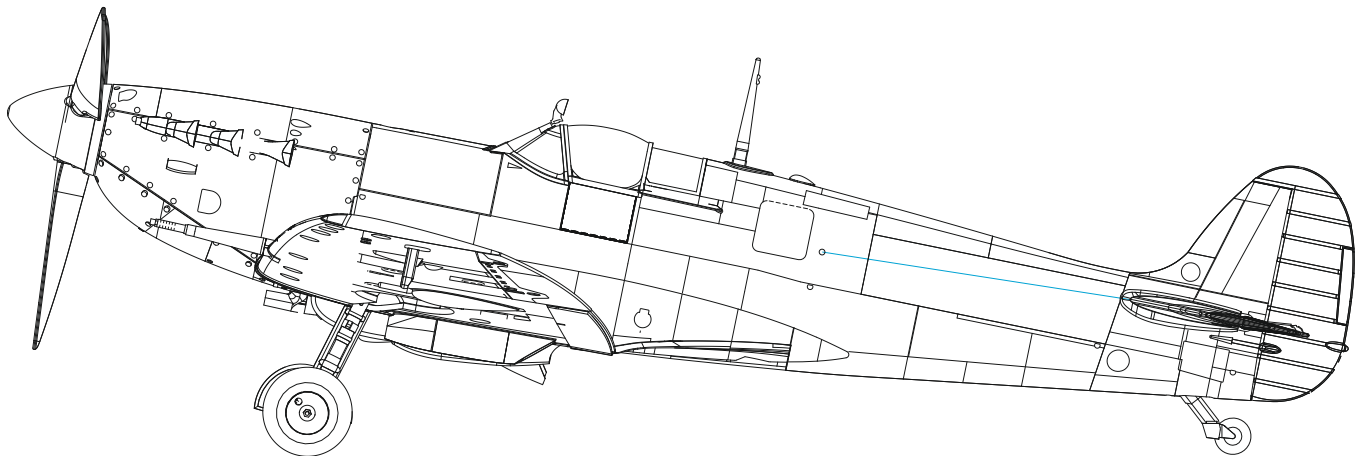
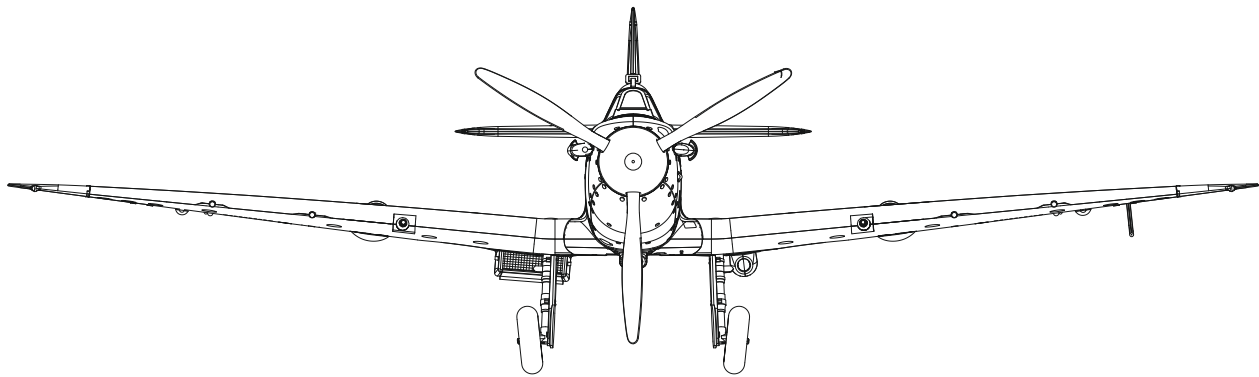

**H**

A13, A14, A15 - CLOSED CANOPY  
 A9, A10, A19 - OPEN CANOPY

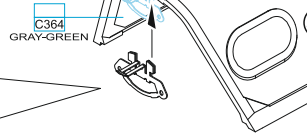
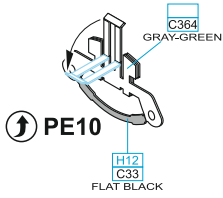

★A10 ? A15★  
 ★A9 ? A13★  
 ★A14 ? A19★

A10 ? A15 - MARKINGS **A, B, C, D, F**  
 A9 ? A13 - MARKINGS **E, G, H, I**  
 A14 ? A19 - MARKINGS **J, K**

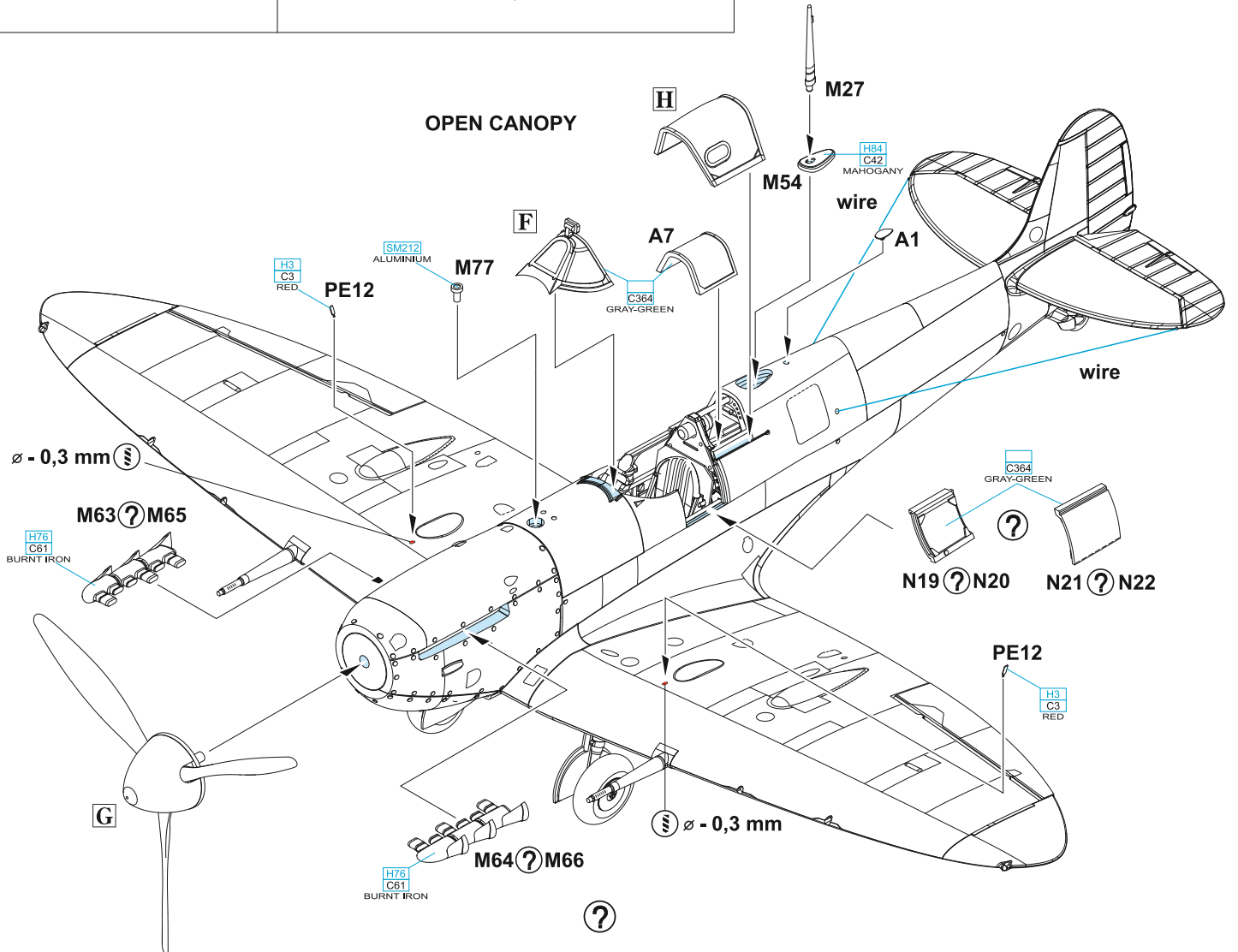
**OPEN CANOPY****CLOSED CANOPY**

M63, M64 - MARKINGS **A, C, D, E, F, G, H, I, J, K**  
 M65, M66 - MARKING **B**

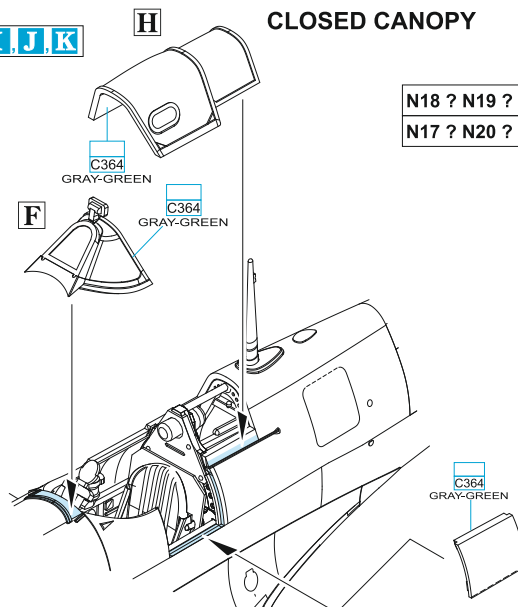

N18 ? N19 ? N22 - MARKINGS **A, B, F, H, I, J, K**  
 N17 ? N20 ? N21 - MARKINGS **C, D, E, G**

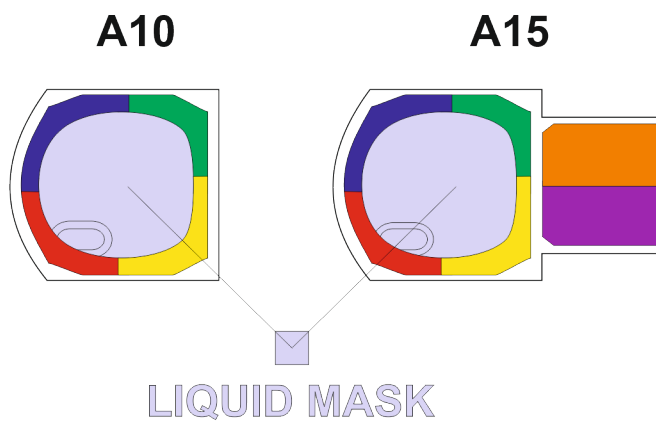
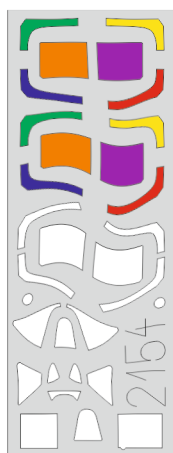
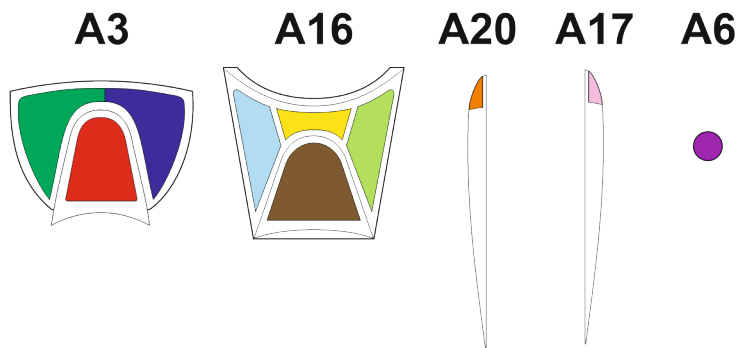
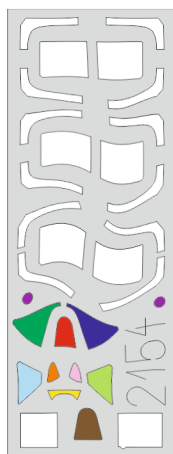
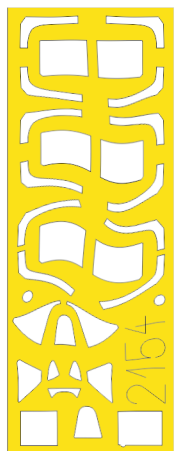

LIQUID MASK

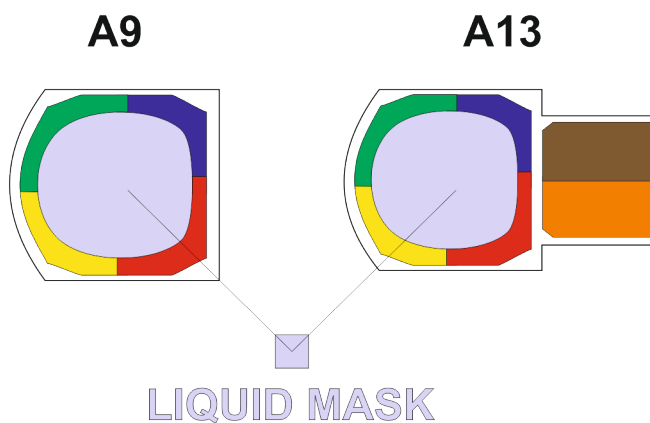
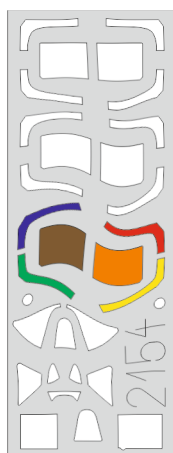

LIQUID MASK

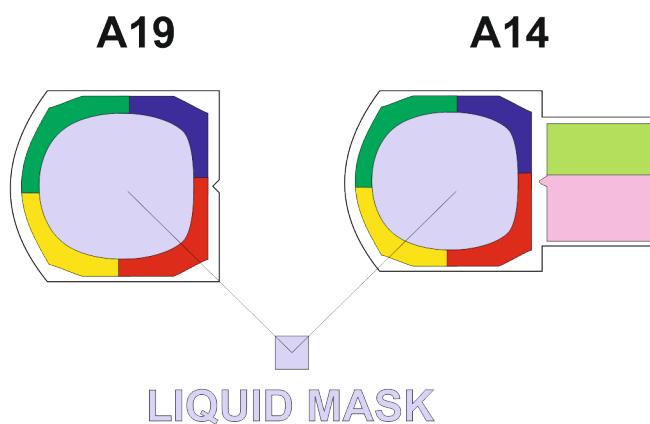
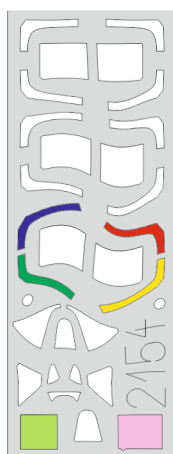

LIQUID MASK

# A W3457, F/O James E. Johnson, No. 616 Squadron, RAF Tangmere, United Kingdom, August 1941

"Johnnie" Johnson was the Commonwealth's most successful fighter ace with 41 confirmed kills. After pilot training in August 1940, he was briefly assigned to No. 19 Squadron and transferred to No. 616 Squadron in early September. In the spring of 1941, Tangmere Wing commander Douglas Bader chose him as his wingman in his four-man formation. After Bader was shot down and captured on August 9, 1941, Johnson had the words BADER'S BUS Co. STILL RUNNING painted on the left side of the fuel tank cover of his Spitfire W3457. On the right side of the fuselage, W3457 bore the inscription CYNON VALLEY, referring to the urban areas of Aberdare and Mountain Ash Glamorgan, which had paid for this Spitfire through a fundraising campaign. Preserved photographs confirm the application of the new Fighter Command camouflage valid from August 15, 1941, in shades of Dark Green, Mixed Gray, and Medium Sea Gray.

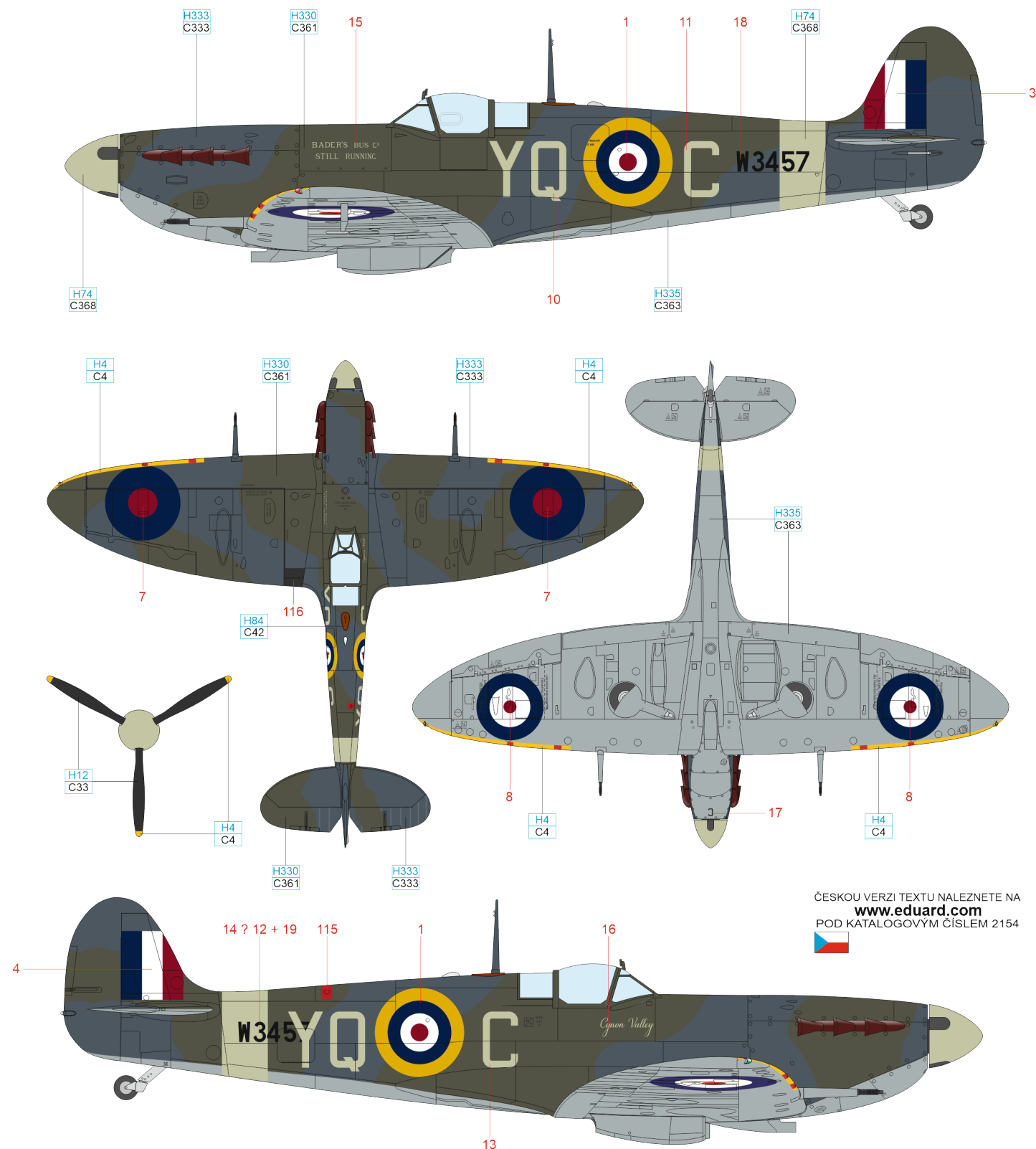

ČESKOU VERZI TEXTU NALEZNETE NA  
[www.eduard.com](http://www.eduard.com)  
 POD KATALOGOVÝM ČÍSLEM 2154



FLAT BLACK	H12 C33	MAHOGANY	H84 C42	YELLOW	H4 C4
SKY	H74 C368	DARK GREEN	H330 C361	EXTR. DARK SEAGRAY	H333 C333
				MEDIUM SEAGRAY	H335 C363

# B W3817, S/Ldr Richard M. Milne, No. 92 squadron, RAF Gravessend, United Kingdom, August-December 1941

"Dickie" Milne became an ace with No. 151 Squadron during the Battle of Britain and was transferred to No. 92 Squadron based at Biggin Hill in mid-1941. Initially, he was serving as commander of A Flight but overtook the command of the entire Squadron in September. On January 19, 1942, he took command of No. 222 Squadron at North Weald and led it until May, when he ended his operational tour. In early January 1943, he was appointed commander of the elite wing at Biggin Hill. On March 14, 1943, after shooting down an Fw 190, Dickie was shot down by an Fw 190A-4 from II./JG 26 during a dogfight over Berck-Sur-Mer and was captured. After his liberation in May 1945, he was discharged from the RAF in 1946 as a Wing Commander. During his wartime career, he shot down 15 enemy aircraft plus one probably and damaged 11. The Spitfire W3817, which Milne flew as commander of No. 92 Squadron, was a presentation aircraft from Wellinborough, acquired with funds raised by the Northamptonshire Evening Telegraph. It already bore the new Fighter Command camouflage in shades of Dark Green, Ocean Grey (Mixed Grey), and Medium Sea Grey. On the left side of the fuel tank cover, it bore the inscription "New Yorklin" and under the cockpit there were 11 black and white crosses painted as killmarks.

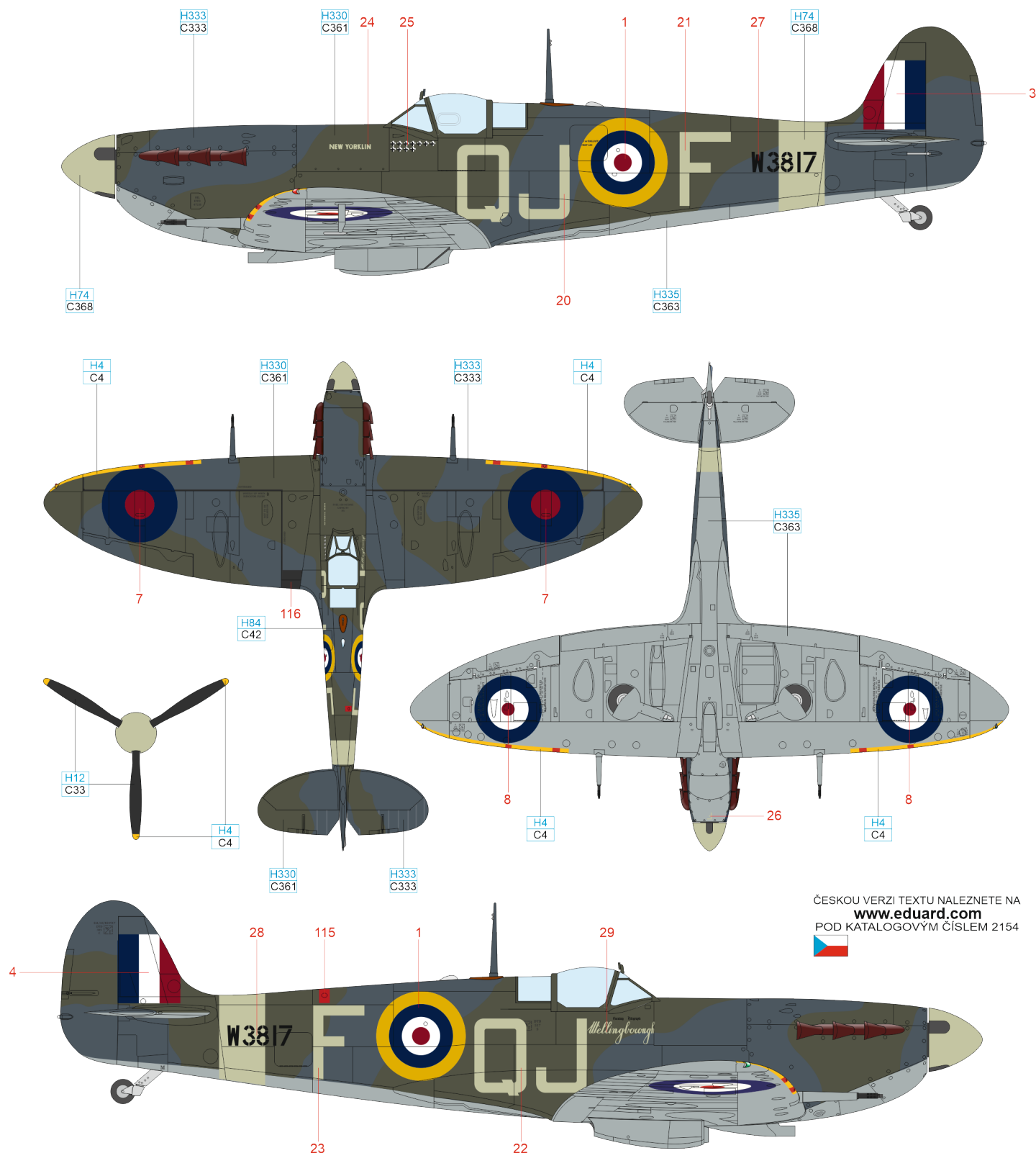

ČESKOU VERZI TEXTU NALEZNETE NA [www.eduard.com](http://www.eduard.com) POD KATALOGOVÝM ČÍSLEM 2154



FLAT BLACK	H12 C33	MAHOGANY	H84 C42	YELLOW	H4 C4
SKY	H74 C368	DARK GREEN	H330 C361	EXTR. DARK SEAGRAY	H333 C333
				MEDIUM SEAGRAY	H335 C363

# C BL973, F/Lt Stanislav Fejfar, No. 313 (Czechoslovak) Squadron, RAF Hornchurch, United Kingdom, March-May 1942

Stanislav Fejfar, a member of Czechoslovak Air Force before the war, flew as commander of 45<sup>th</sup> Fighter Squadron based in Slovakia during the Munich crisis. He scored his first two kills during the Battle of France as a member of Armee de l'Air flying MS.406 with GC I/6. On July 12, 1940 he arrived in Great Britain aboard the ship Neuralia. On September 9, he started his operational career as a Pilot Officer with No. 310 (Czechoslovak) Squadron RAF scoring his first out of three kills claimed during the Battle of Britain. On July 21, 1941, he joined No. 313 (Czechoslovak) Squadron as a F/Lt in the position of B Flight leader. Stanislav Fejfar perished on May 17, 1942, in the cockpit of Spitfire Mk.Vb BL973 during the Ramrod 33 mission. He was shot down by Hptm. Josef Priller between Guines and Audebert in the northern France. A couple of days earlier Priller had also shot down Sergeant Karel Pavlík, author of Pluto the Dog nose art on Fejfar's Spitfire.

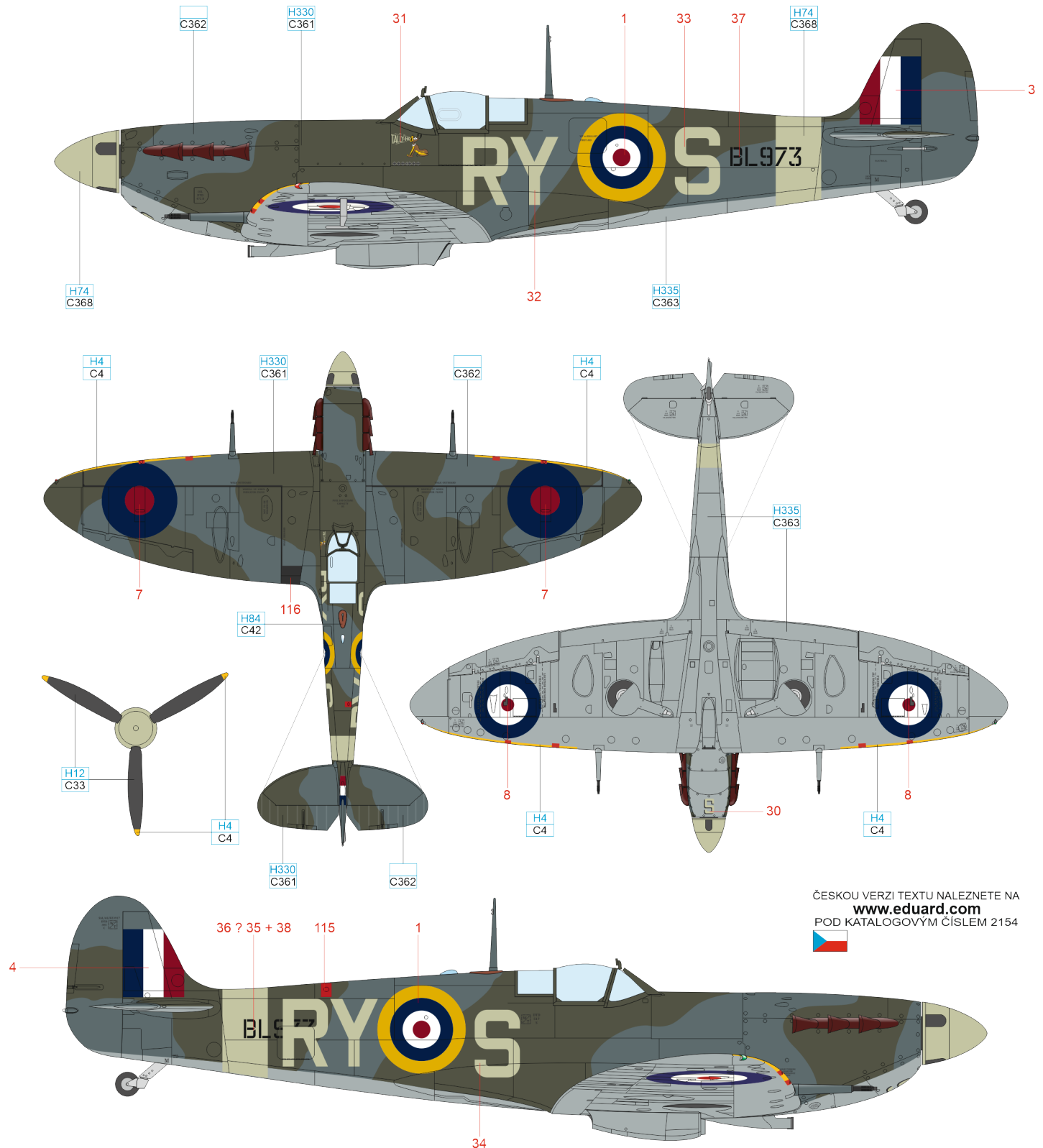

ČESKOU VERZI TEXTU NALEZNETE NA  
[www.eduard.com](http://www.eduard.com)  
 POD KATALOGOVÝM ČÍSLEM 2154



FLAT BLACK	H12 C33	MAHOGANY	H84 C42	YELLOW	H4 C4
SKY	H74 C368	DARK GREEN	H330 C361	OCEAN GRAY	C362
		MEDIUM SEAGRAY	H335 C363		

# D BM124, S/Ldr Brendan E. F. Finucane, CO of No. 602 Squadron, RAF Kenley, United Kingdom, April 1942

Spitfire s/n BM124 was a presentation aircraft donated to Britain by Queen Salote of Tonga and assigned to S/Ldr Brendan Finucane. It was delivered on March 14, 1942, and Finucane was flying with it continuously until June 18, 1942, when he hit the ground with the tip of the wing while landing at Redhill. The aircraft was severely damaged, and although it was returned to the unit after extensive repairs, Finucane did not fly it again. He scored his last victories in its cockpit. Finucane's BM124, was repainted on the upper surfaces in Dark Slate Grey / Extra Dark Sea Grey naval shades. Under the front badge, he had his personal Shamrock emblem and the fuselage letter W painted on. For propaganda purposes, the inscription QUEEN of SALOTE was painted on the fuel tank cover in May. As it later turned out, the inscription was not written correctly, and the Air Ministry submitted an amendment requesting that the photographs taken be changed from QUEEN of SALOTE to QUEEN SALOTE. The word "of" was thus roughly scraped off the negatives. Out of respect for the origins and traditions of No. 602 Squadron, Finucane had the squadron's emblem, a red Scottish lion rampant in a yellow shield, placed on the engine cowlings of the No. 602 Squadron Spitfires. During his wartime career, Finucane achieved 32 aerial victories, becoming the third most successful Spitfire pilot during World War II.

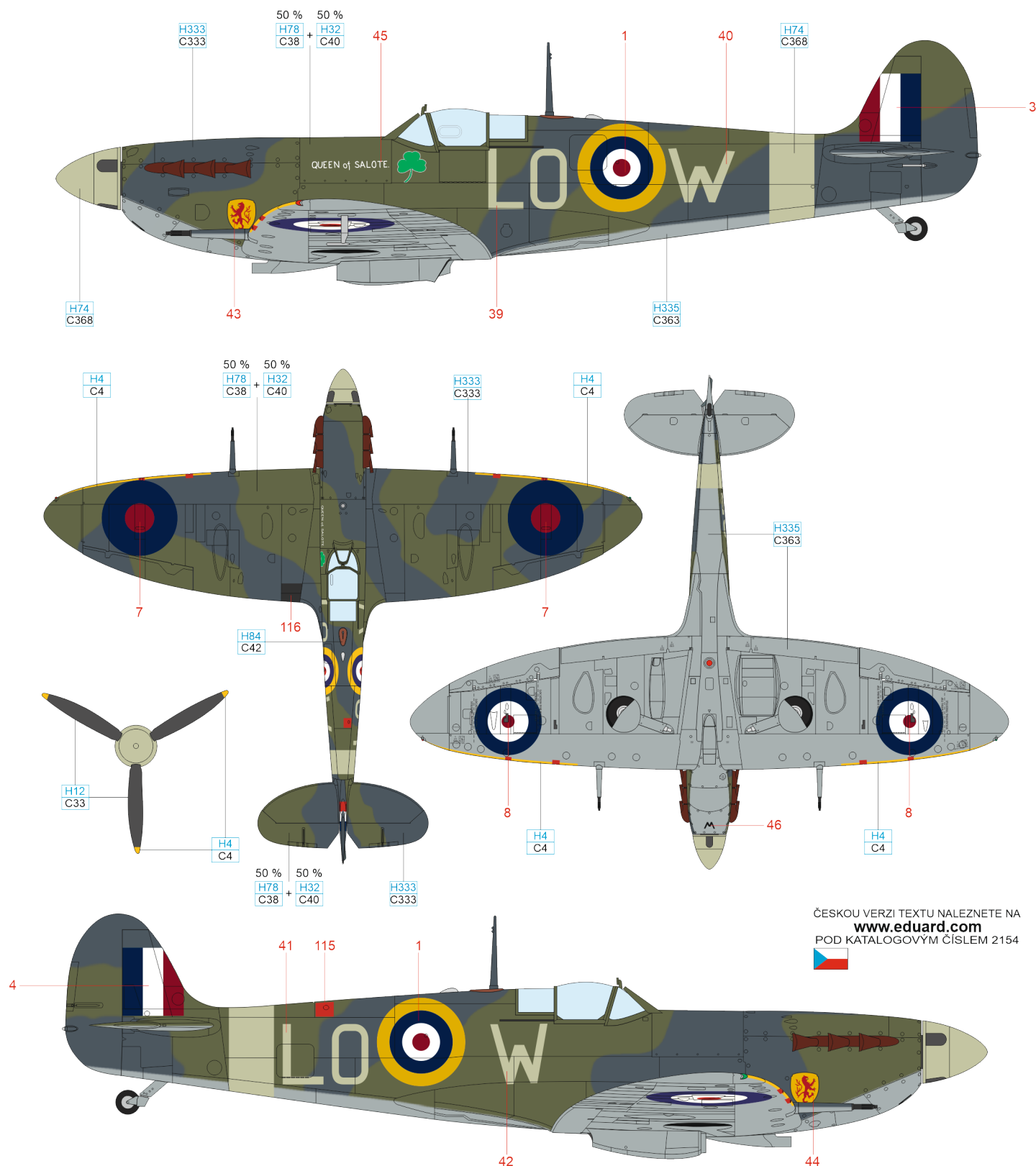

ČESKOU VERZI TEXTU NALEZNETE NA  
[www.eduard.com](http://www.eduard.com)  
 POD KATALOGOVÝM ČÍSLEM 2154



FLAT BLACK	H12 C33	MAHOGANY	H84 C42	YELLOW	H4 C4	EXTR. DARK SEAGRAY	H333 C333
SKY	H74 C368	OLIVE GREEN	H78 C38	FIELD GRAY	H32 C40	MEDIUM SEAGRAY	H335 C363





**G** EN951, S/Ldr Jan Zumbach, CO of No. 303 (Polish) Squadron, RAF Kirton in Lindsey, United Kingdom, September 1942

Jan Zumbach, a grandson of a Swiss emigrant, Swiss citizen himself, served with No. 111 Fighter Squadron of the Polish Air Force from 1938. After Poland was defeated he fought in the ranks of the French GCD I/55. On August 2, 1940, he joined No. 303 (Polish) Squadron with which he scored eight kills during the Battle of Britain. On May 17, 1942, he was given command of No. 303 (Polish) Squadron. From the end of September till December 1942 he flew Spitfire EN951, the former personal mount of Don Blakeslee from the USAAF 336<sup>th</sup> FS, 4<sup>th</sup> FG. The aircraft sported Zumbach's personal emblem in the form of Donald the Duck nose art, known in several versions from several Zumbach's Spitfires. During the war, in which end he was shot down and briefly imprisoned, Jan Zumbach's total score was thirteen confirmed kills and five probables. His life after the war is no less colorful than during wartime. He engaged in the international arm dealing, often illegal, and fought as a mercenary in Africa, in the service of the insurgent forces in Katanga and later Biafra. He died under unclear circumstances in Paris on January 3, 1986.

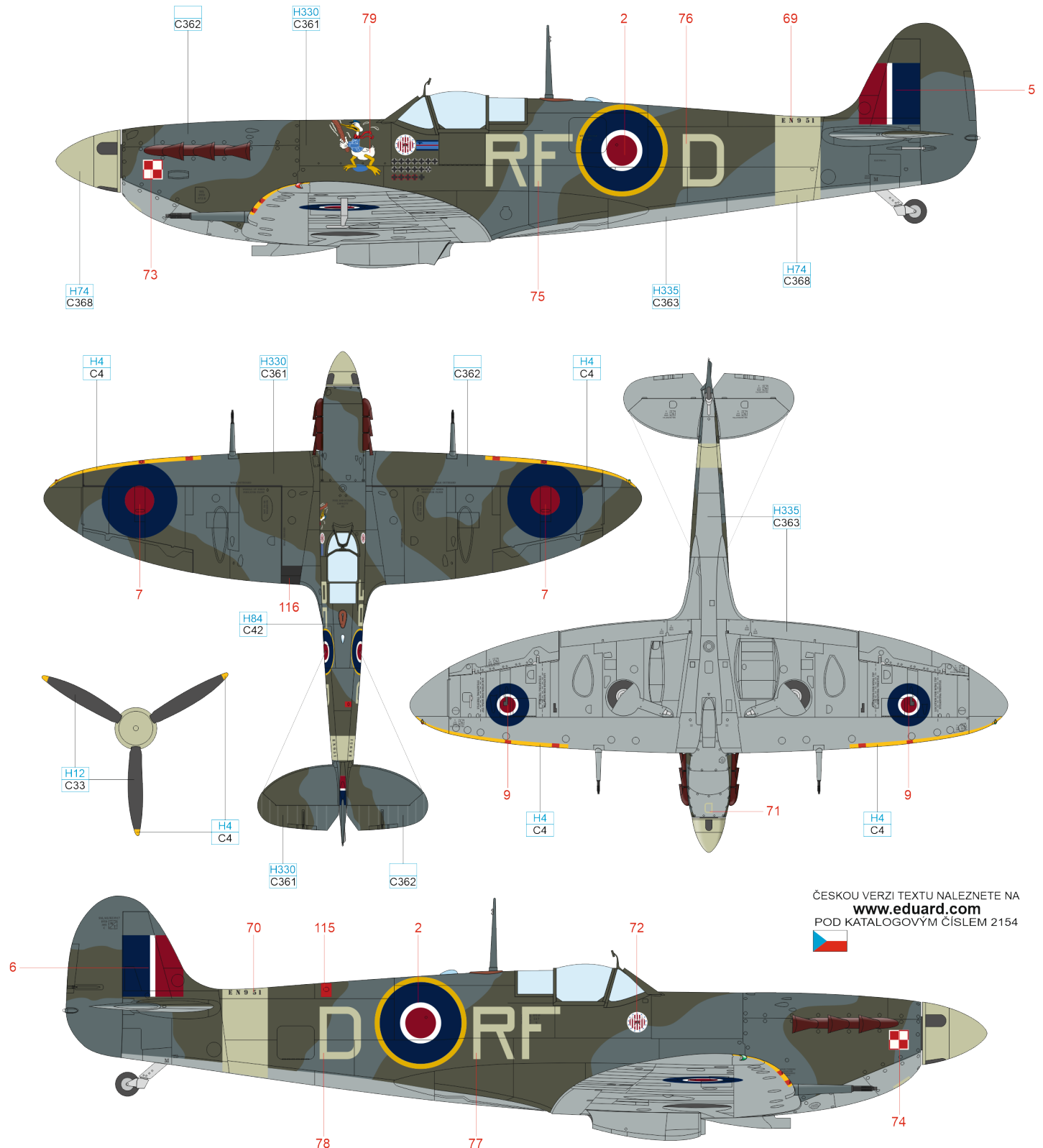

ČESKOU VERZI TEXTU NALEZNETE NA  
**www.eduard.com**  
 POD KATALOGOVÝM ČÍSLEM 2154



FLAT BLACK	H12 C33	MAHOGANY	H84 C42	YELLOW	H4 C4
SKY	H74 C368	DARK GREEN	H330 C361	OCEAN GRAY	C362
		MEDIUM SEAGRAY	H335 C363		

# H EN824, F/Lt John Yarra, No. 453 Squadron RAAF, RAF Ipswich, United Kingdom, December 1942

Nicknamed "Slim", Yarra was one of the most successful pilots defending the island of Malta during the hot summer of 1942. During the tough battles for Malta he scored 12 kills. In September 1942 he was promoted to Flight Lieutenant and assigned to the Australian No. 453 Squadron, part of the Hornchurch Wing, flying offensive raids over France. F/Lt Yarra's fateful date came on December 10, 1942, when during the attack on a shipping at the Holland coast, his Spitfire EN824 was hit by AA fire and crashed into the sea. He tried to bail out of the damaged aircraft but was hit by the tail surfaces damaging his parachute, which did not fully deploy. Pilot's body hit the sea surface falling from 300 meters. His brother Robert Ernest, fighter pilot as well, was also shot down by the AA fire and killed on April 14, 1944, while attacking the V-1 missiles launching pads at Ligescourt (operation Ramrod 735).

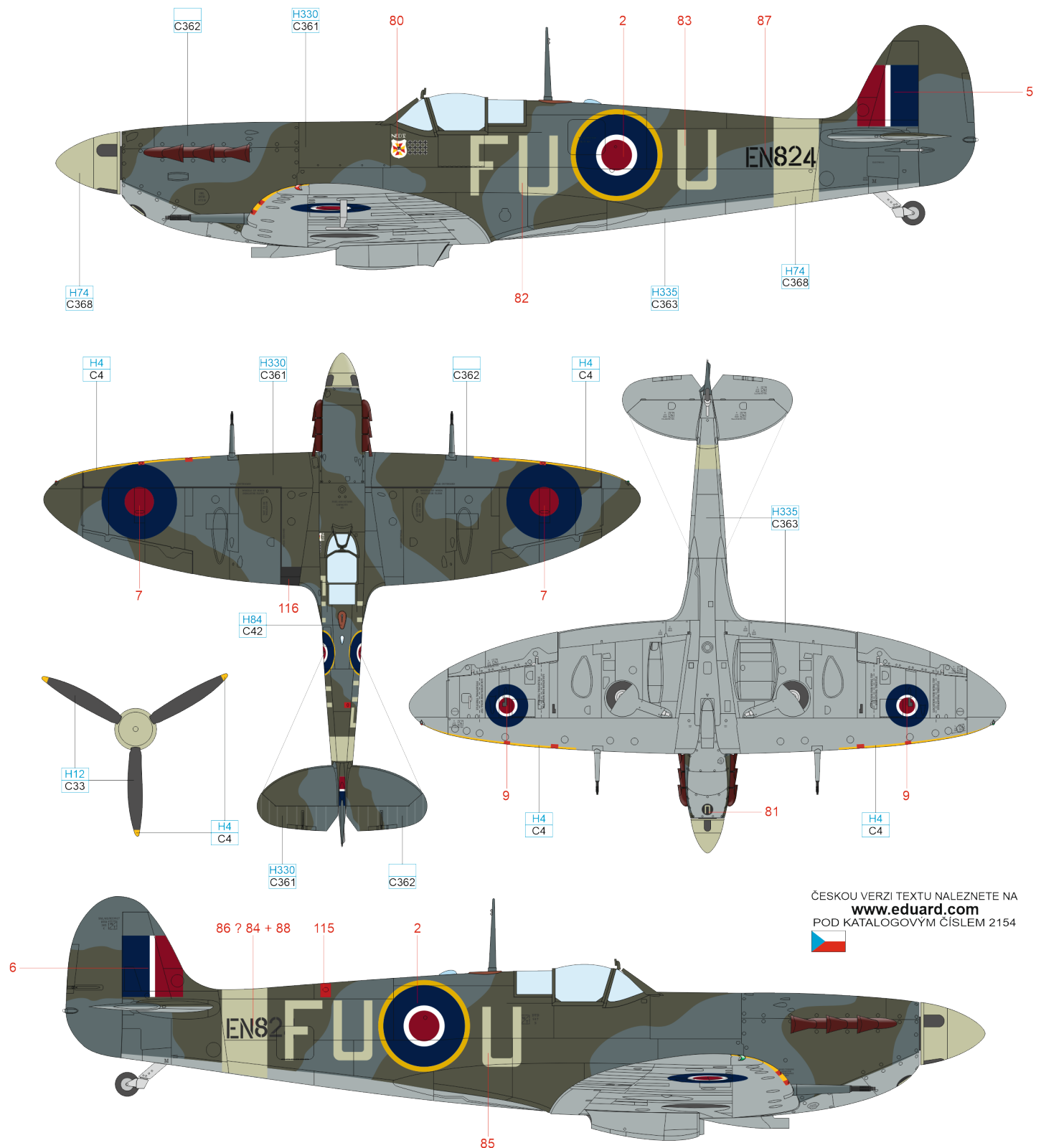

ČESKOU VERZI TEXTU NALEZNETE NA  
[www.eduard.com](http://www.eduard.com)  
 POD KATALOGOVÝM ČÍSLEM 2154



FLAT BLACK	H12 C33	MAHOGANY	H84 C42	YELLOW	H4 C4
SKY	H74 C368	DARK GREEN	H330 C361	OCEAN GRAY	C362
		MEDIUM SEAGRAY	H335 C363		



# J EN921, F/O Jackson E. Sheppard, No. 401 Squadron RCAF, RAF Biggin Hill, United Kingdom, October 1943

"Jack" Sheppard, originally a dock worker, enlisted in the RCAF in 1939 and till August 1940 served with No. 120 Squadron. In August 1941 he completed the pilot training at No. 53 OTU and in November 1941 was assigned to No. 43 Squadron. In December he volunteered for the convoy escorts. On February 10, 1942, he crashed into the sea in Hurricane Z4569 having been catapulted from a deck of a transport boat. In July 1943 he became an A Flight leader with No. 401 Squadron. In April 1944 he assumed command of a flight of the No. 412 Squadron and led the unit till August 2 when he was shot down by German fighters in Normandy. He managed to avoid capture and returned to the unit. On August 22 he was decorated with DFC and in October he returned to Canada. In February 1946 he finally left the military service. Jackson Sheppard flew Spitfire serialied EN921 on regular basis from July till October 1943. Even though he did not score any of his five kills in its cockpit, he flew this aircraft on many offensive sweeps including the mock operation Starkey on September 9, 1943.

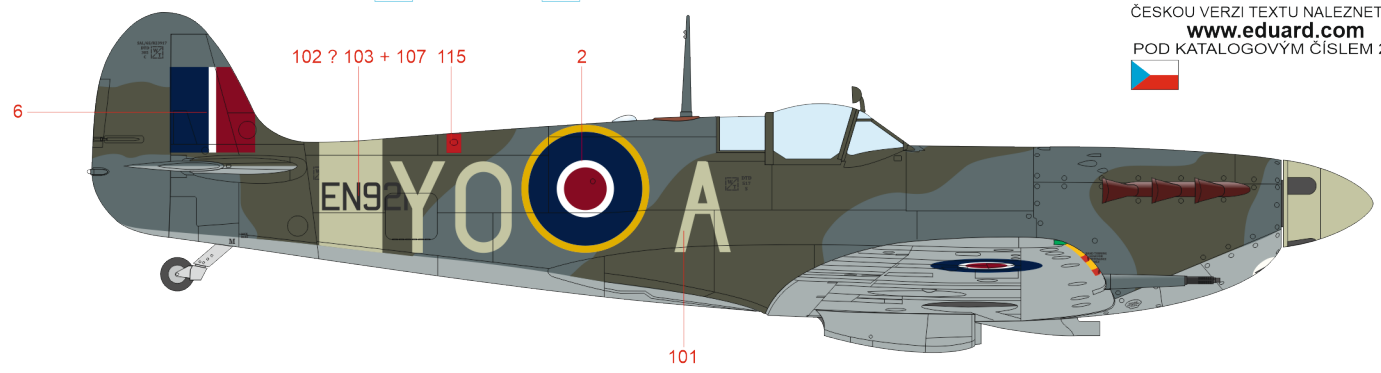
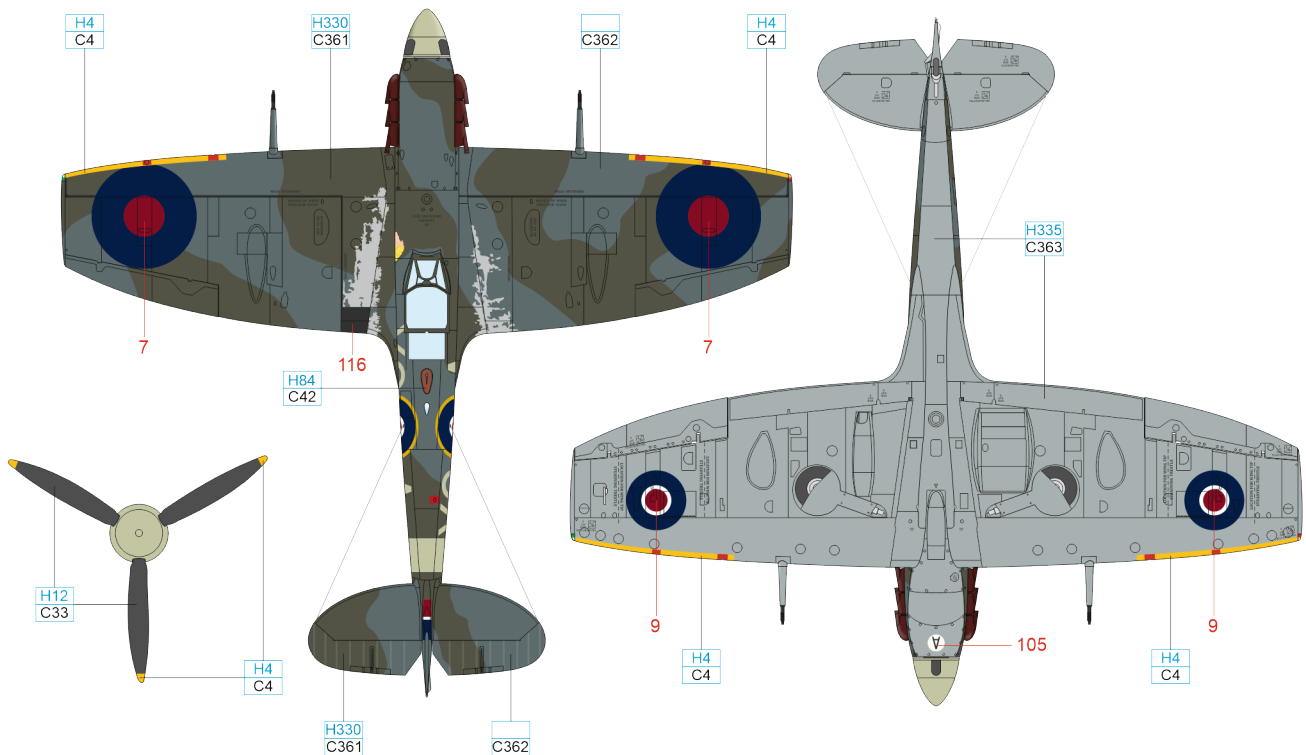
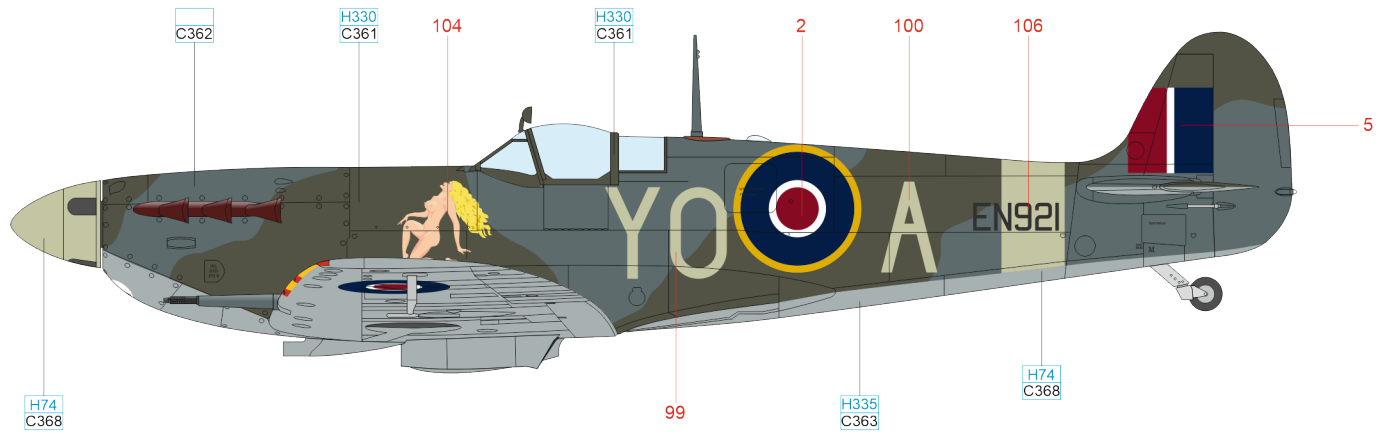

ČESKOU VERZI TEXTU NALEZNETE NA  
[www.eduard.com](http://www.eduard.com)  
 POD KATALOGOVÝM ČÍSLEM 2154



FLAT BLACK	H12 C33	MAHOGANY	H84 C42	YELLOW	H4 C4	WHITE	H11 C62
SKY	H74 C368	DARK GREEN	H330 C361	OCEAN GRAY	C362	MEDIUM SEAGRAY	H335 C363

# K EP829, S/Ldr John J. Lynch, No. 249 Squadron, Krendi, Malta, May 1943

John Joseph Lynch was born on February 3, 1918, in Alhambra, California. In 1941, he joined the RAF and his first assignment was with No. 232 Squadron. The following month, he was attached to No. 121 "Eagle" Squadron. This was followed by a stint with No. 71 "Eagle" Squadron, during which he shared in the destruction of a Ju 88 on April 17, 1942. In November 1942, he was transferred to Malta and assigned to No. 249 Squadron, with which he actively participated in its defense. At the beginning of 1943, he was promoted to Commander of the unit and recorded a number of victories over Axis transport aircraft supplying Tunisia. The Ju 52 kill came about on April 28, being the 1,000<sup>th</sup> kill recorded by the defenders of Malta. In July 1943, he was reassigned to the USAAF but saw no combat with the service. Spitfire EP829, with which Lynch flew from February to May 1943 as a member of No. 249 Squadron, was part of Operation Train, which represented the final shipment of Spitfires to the defenders of Malta, delivered by an aircraft carrier. EP829 initially had clipped wings and later flew with the standard span wings. The main fuel tank cover carried the Squadron Commander marking and seven kill markings that were recorded up to April 28, 1943. Below the windscreen, there was an inscription "Malta's 1000", in honor of that kill over Malta. Over his combat career, Lynch recorded 17 kills (ten individual and seven shared), along with a single probable and two damaged enemy aircraft.

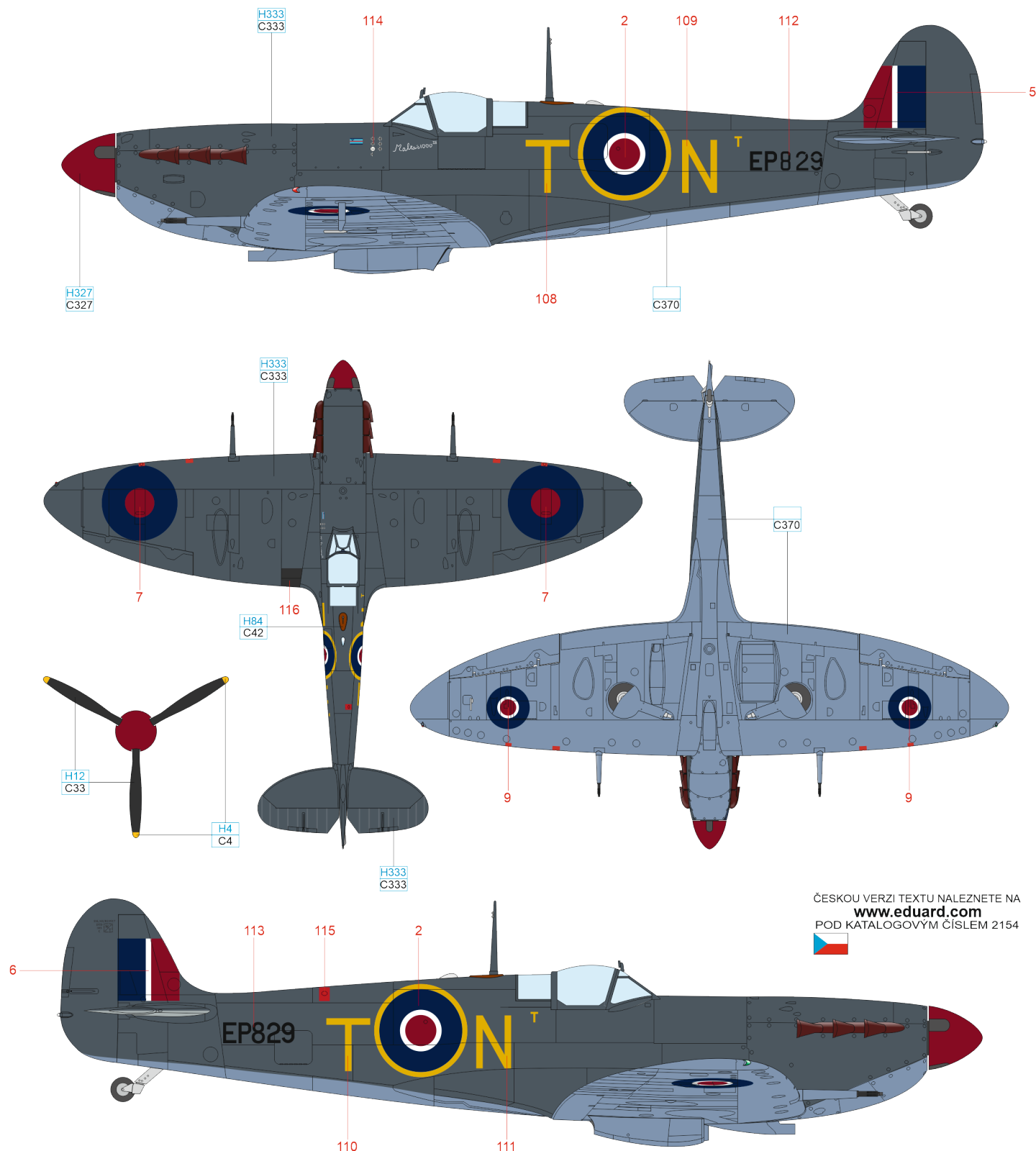

ČESKOU VERZI TEXTU NALEZNETE NA  
[www.eduard.com](http://www.eduard.com)  
 POD KATALOGOVÝM ČÍSLEM 2154



FLAT BLACK	H12 C33	MAHOGANY	H84 C42	YELLOW	H4 C4
RED	H327 C327	EXTR. DARK SEAGRAY	H333 C333	AZURE BLUE	H370 C370

