



Russian T-80BV MBT

俄罗斯T-80BV主战坦克

1/35 SCALE

READ BEFORE ASSEMBLY:

- Study and understand these instructions thoroughly before beginning assembly
- When needed, remove photo-etch parts carefully using a modeling knife or photo etch sprue cutter, being careful not to damage or lose small parts.
- Take extra care in handling photo etch parts in order to avoid injury
- Apply instant cement sparingly to photo etch parts where instructed
- Tools recommended(not included in kit):Plastic and instant cements, sprue cutters,long nose pliers,modeling knife, small files, tweezers, pin vise & scissors. Soft cloth and sandpaper will also assist in construction
- Glue and paint are not included in the kit. Use plastic cement and hobby paints only. Color guide for purchasing paint is included in the kit.

装配之前仔细阅读

- 小心用模型锉刀锉平所有零件表面的注射浇口。
- 小心用刀片切下蚀刻片零件，不要遗失小零件。
- 用强力快干胶水粘合蚀刻片零件和金属轴。过量快干胶水使用可能导致可动零件会粘住，小心涂胶。
- 取蚀刻片时应特别注意安全，防止利边划伤手指。
- 某些零件表面需贴上水贴纸，请选择在装配的同时进行。
- 推荐模型工具(自备)：胶水，水口剪刀，长咀钳，刀片，锉刀，镊子，钳，钻，剪刀，瞬间快干胶。
- 软布同砂纸同时也应该是必备工具。
- 请使用塑料胶水和油漆，模型内不含。



配重
Weight



使用强力胶
Cyanoacrylate glue



钻孔
Make hole

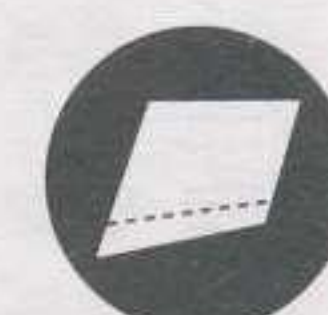

切除
Cut / Remove



贴纸
Decal



锉平
File / Sand



选择
Option



不涂胶水
No cement



弯曲
Bend

水贴纸的使用:

- 1.从水贴纸上剪下印花;
- 2.将印花放入温水中浸10秒, 然后放在干净布上。
- 3.拿着印花纸板将印花移到模型上;
- 4.手指蘸水将印花移到适当的位置;
- 5.用软布轻压印花直至水干, 汽泡消失

DECAL APPLICATION

- 1.Cut decals from sheet as needed
- 2.Dip the decal in warm water for about 10 seconds and then place on soft clean cloth.
- 3.Hold the decal backing sheet edge and gently slide the decal onto the model in its proper position.

- 4.While still wet,decal can be adjusted for better fit on model by dampening it gently with your finger.
- 5.When placed in the proper position,gently press decal down with a soft cloth until excess water and air bubbles are gone.
- 6.Allow decal to dry completely before handling model

部品图

Parts

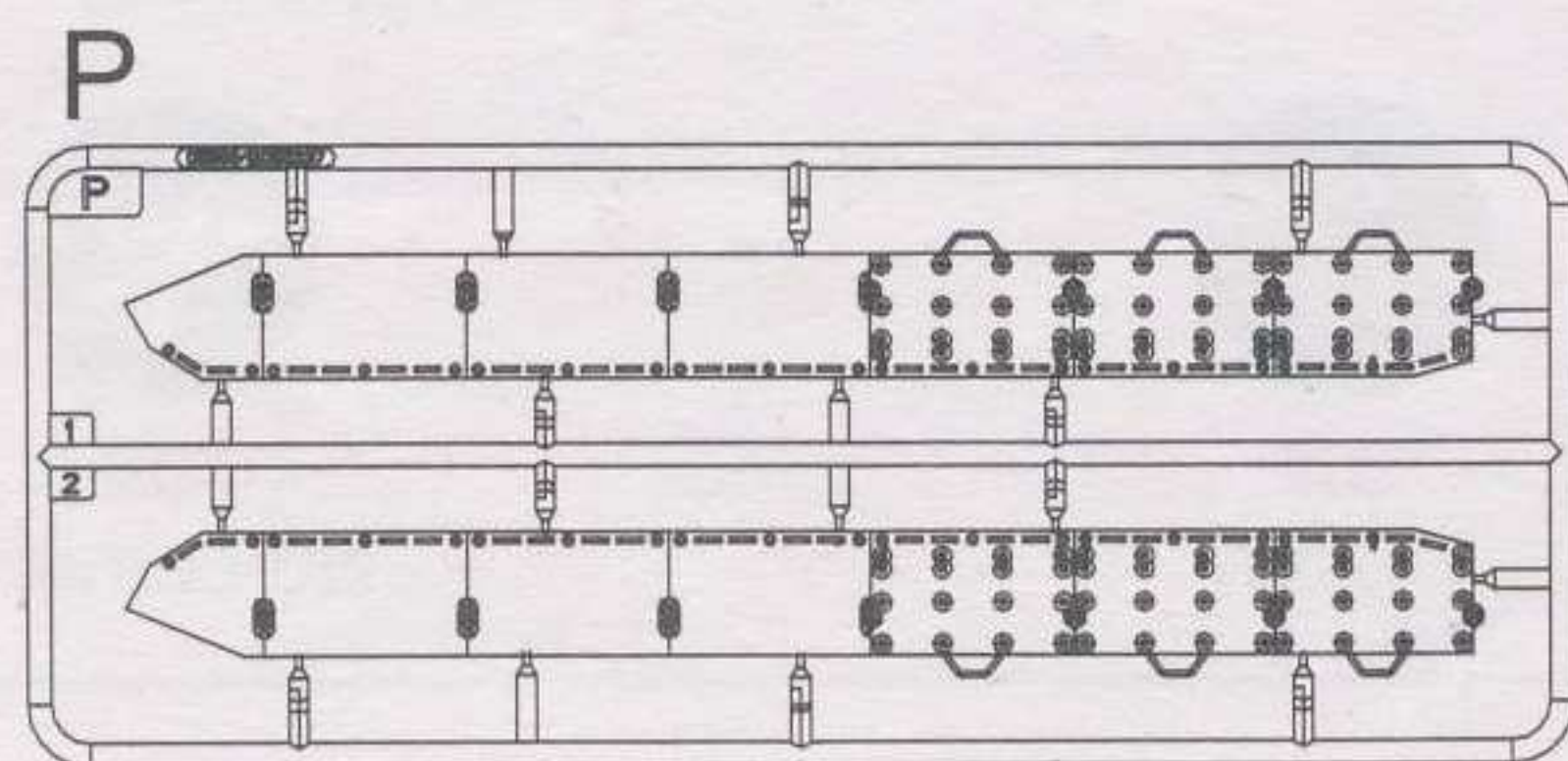
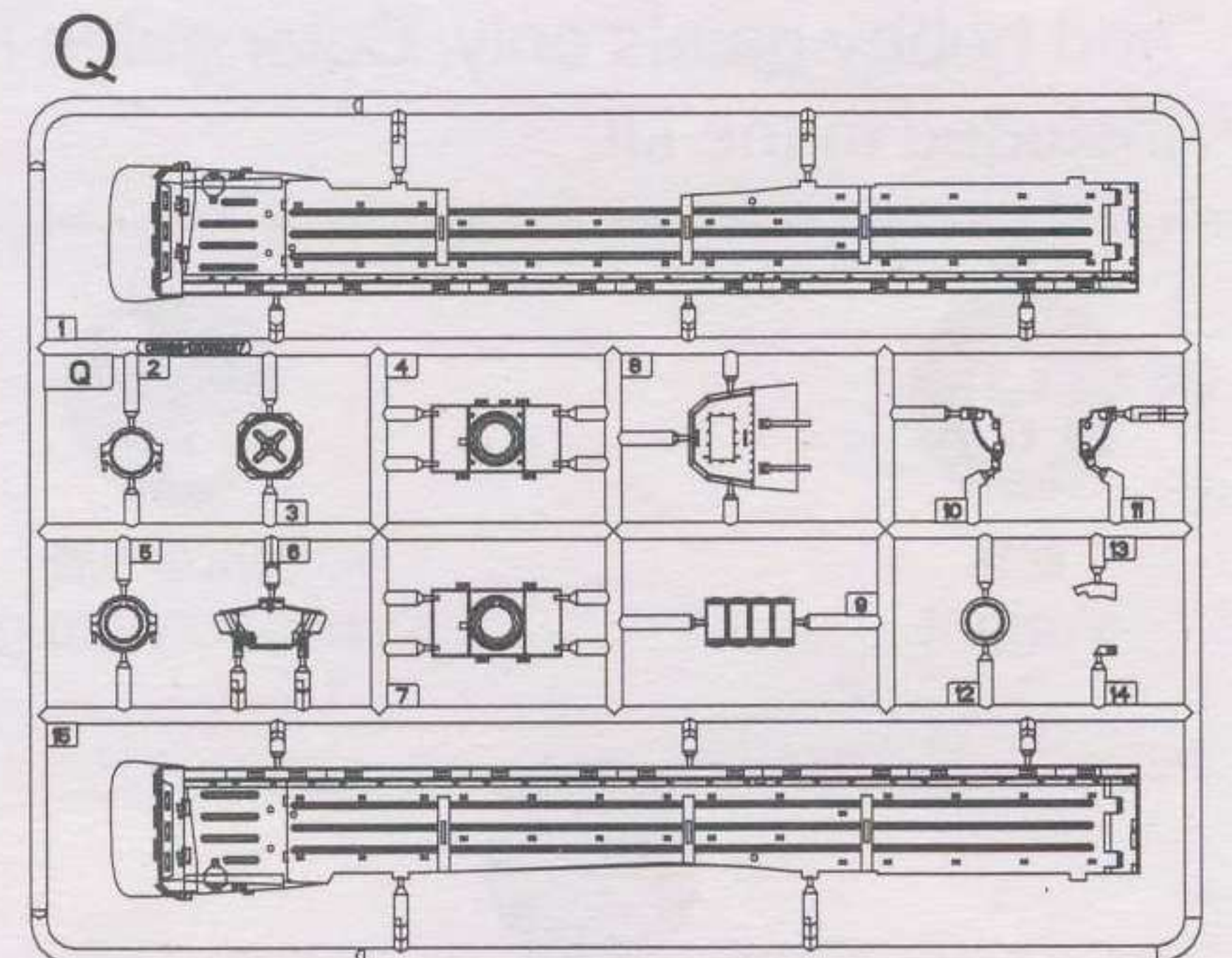
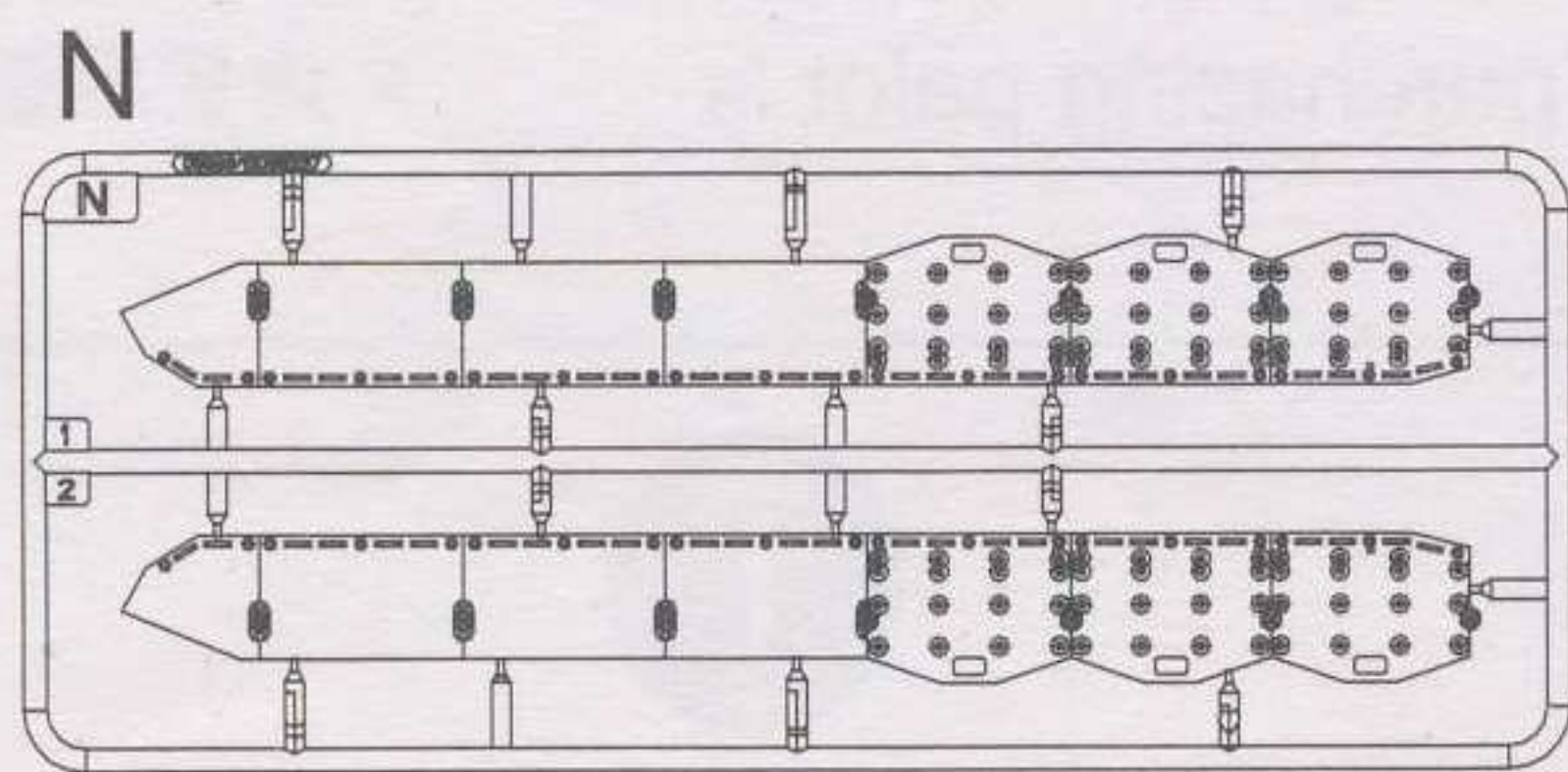
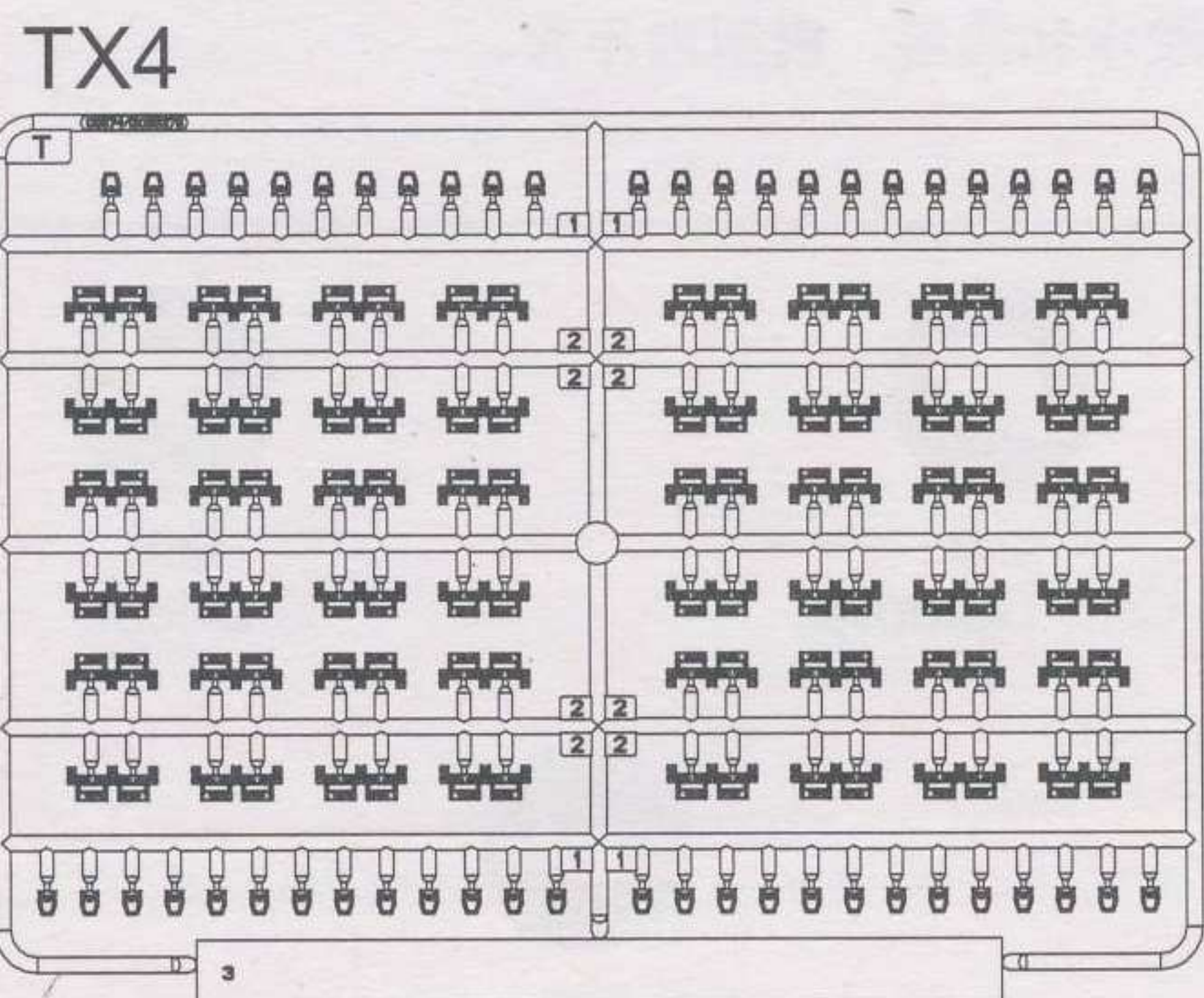
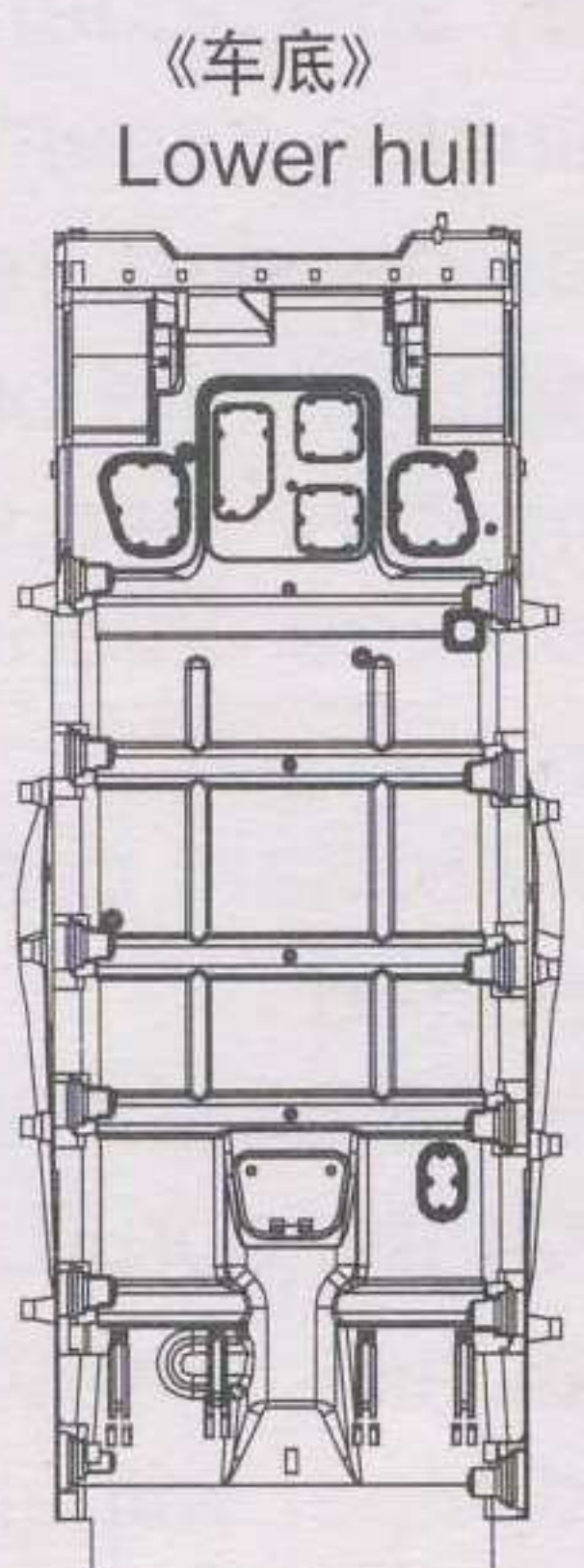
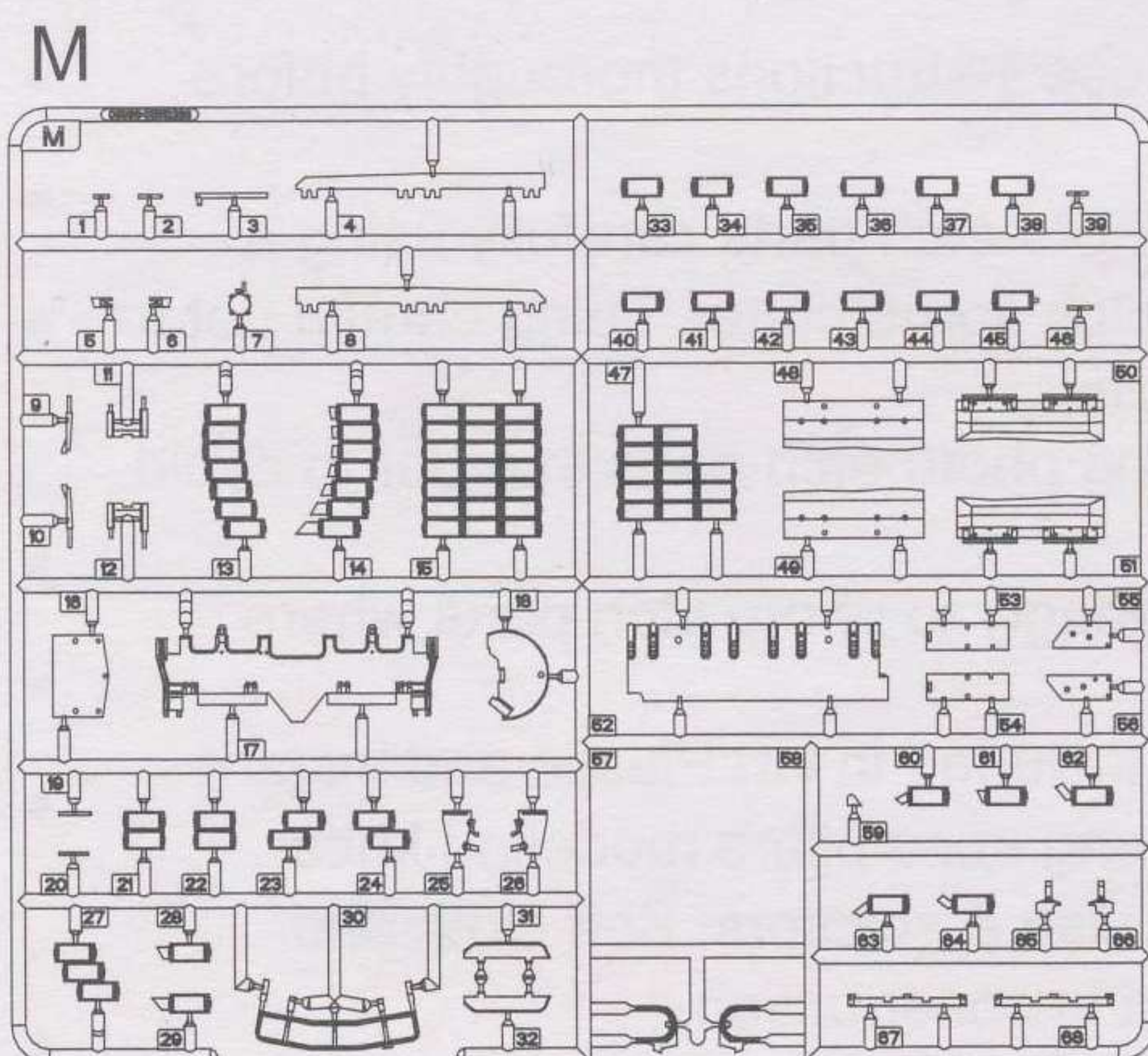
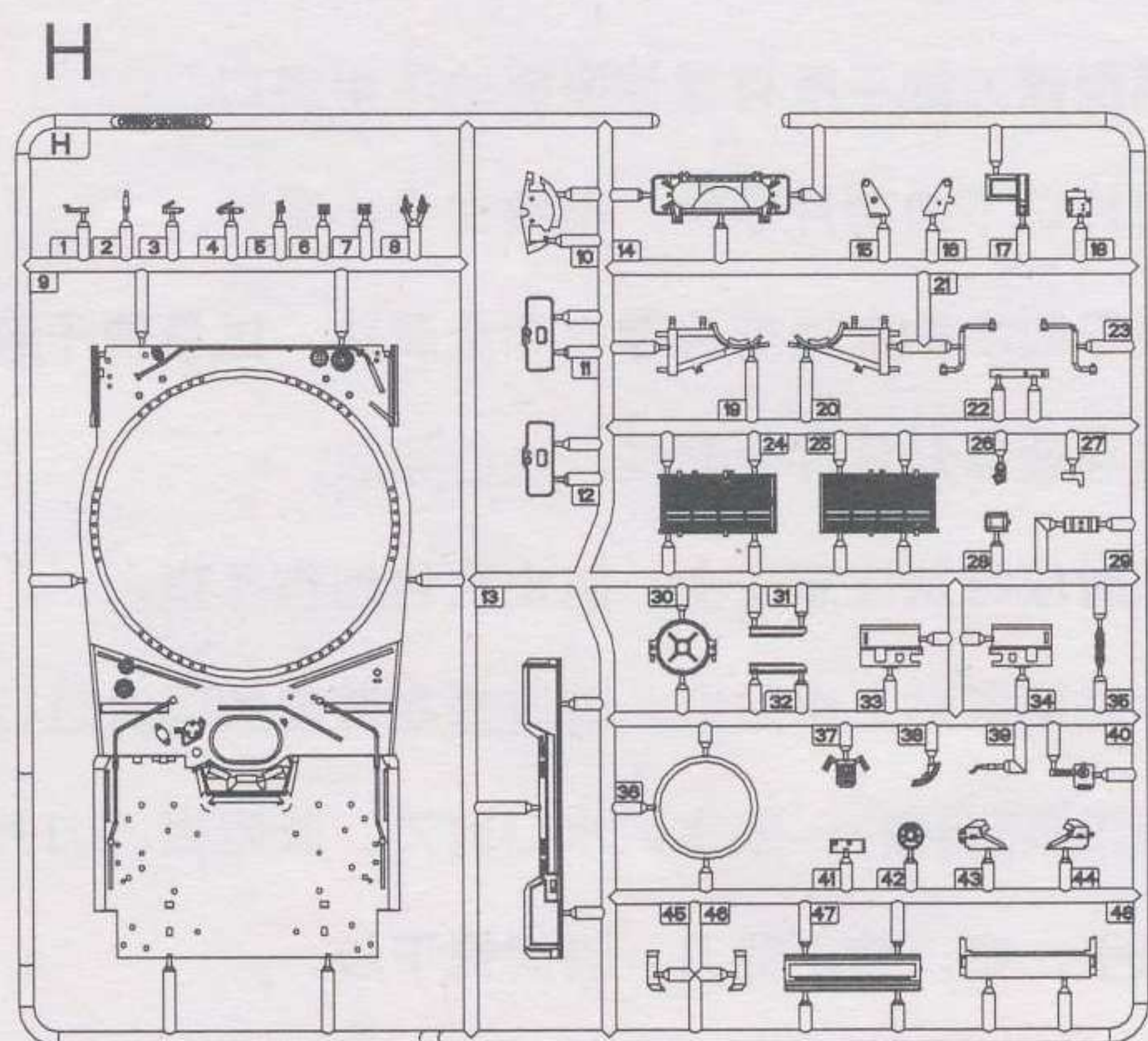
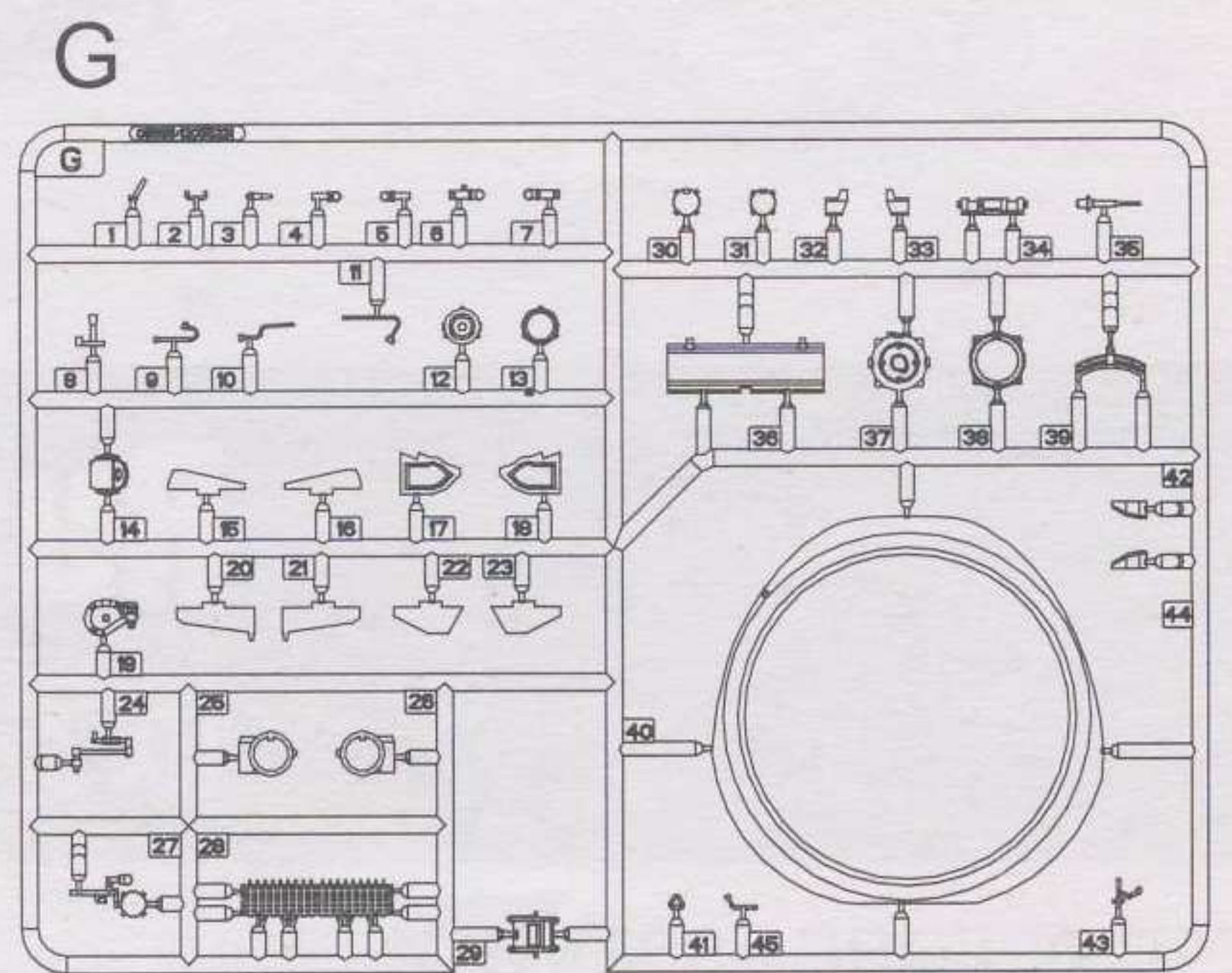
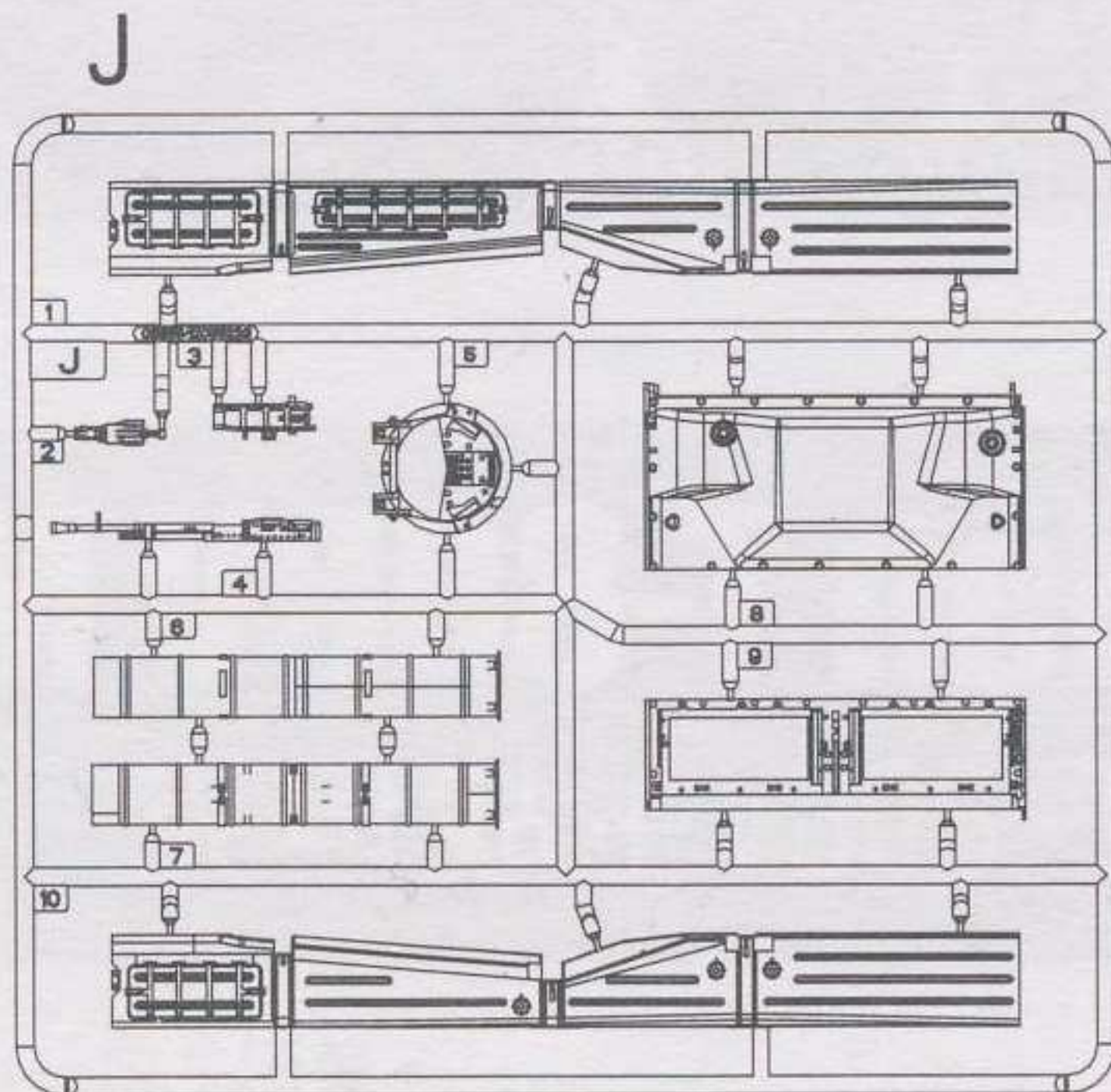
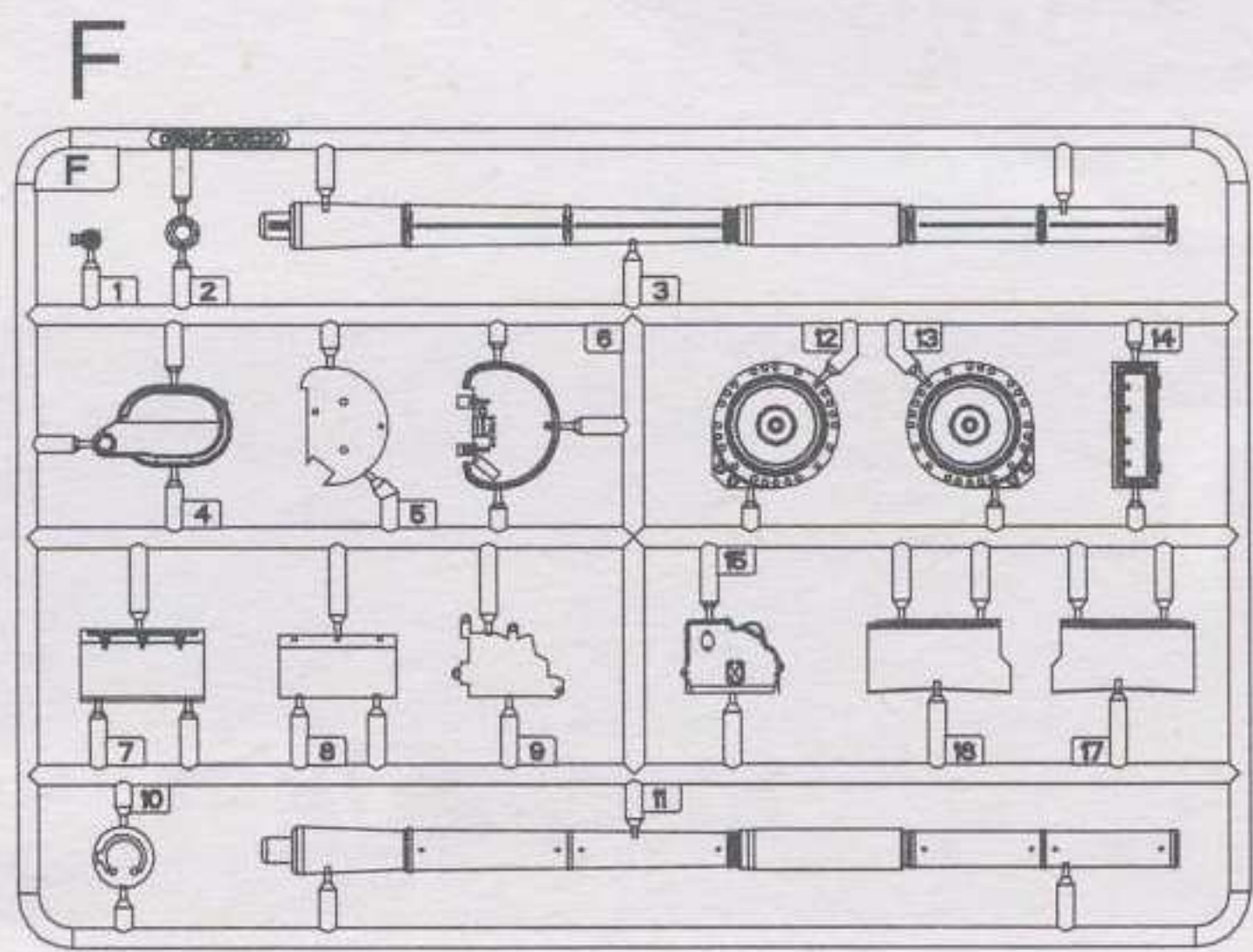
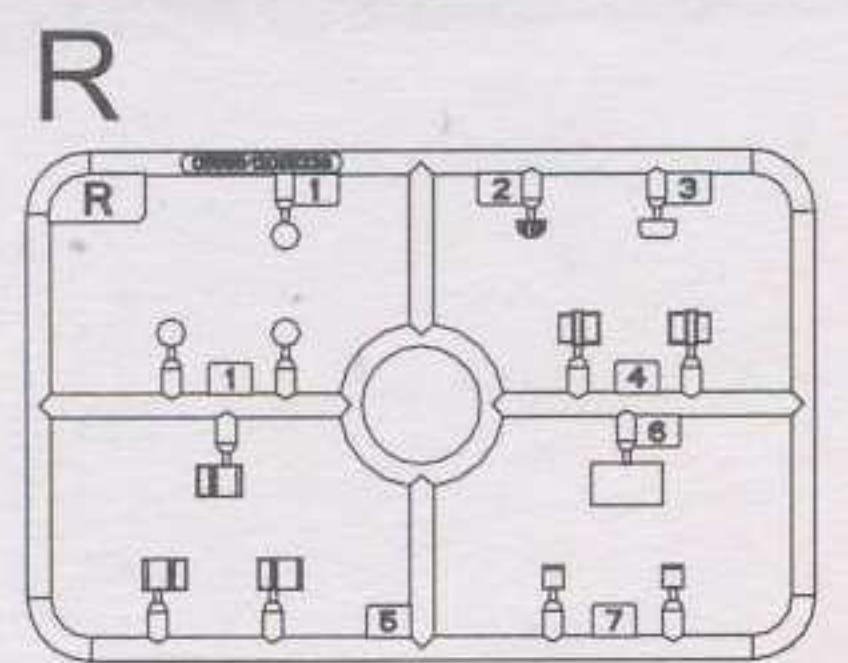
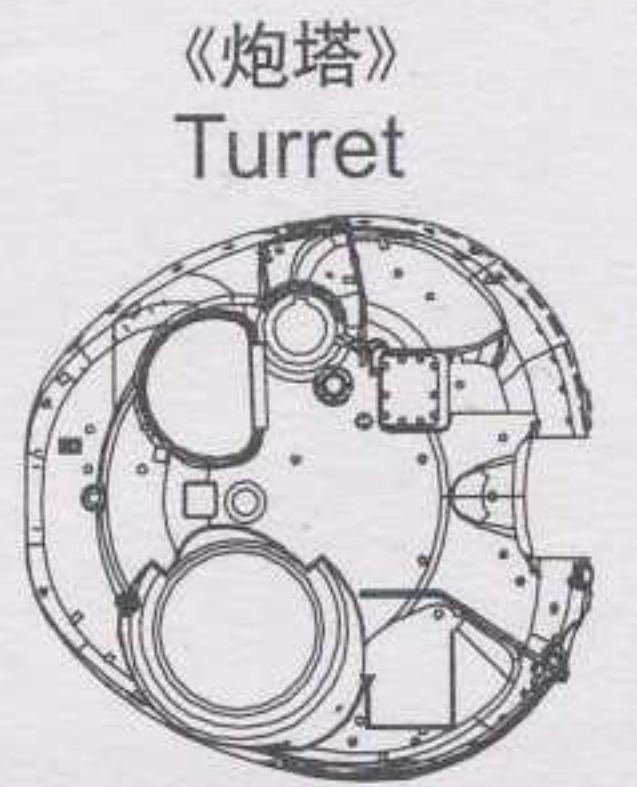
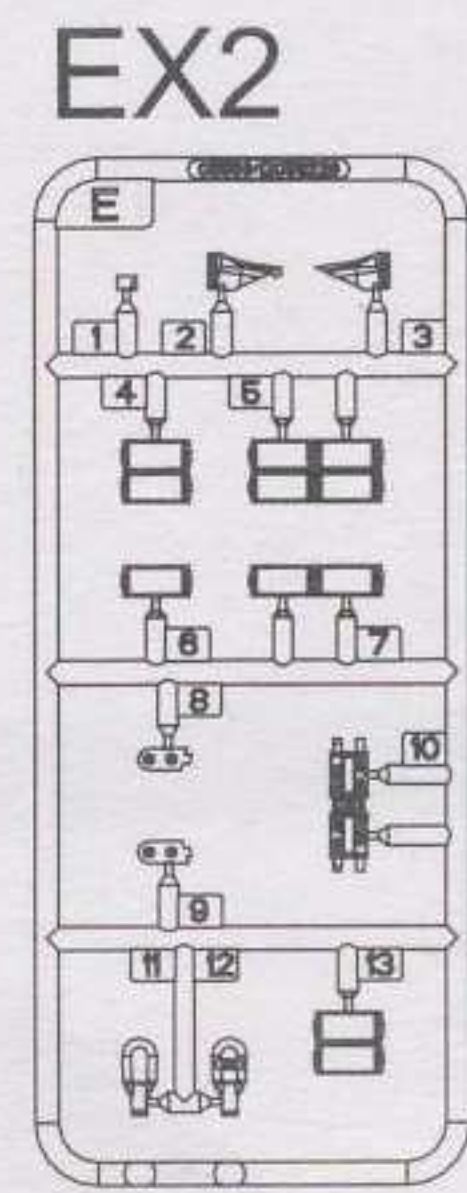
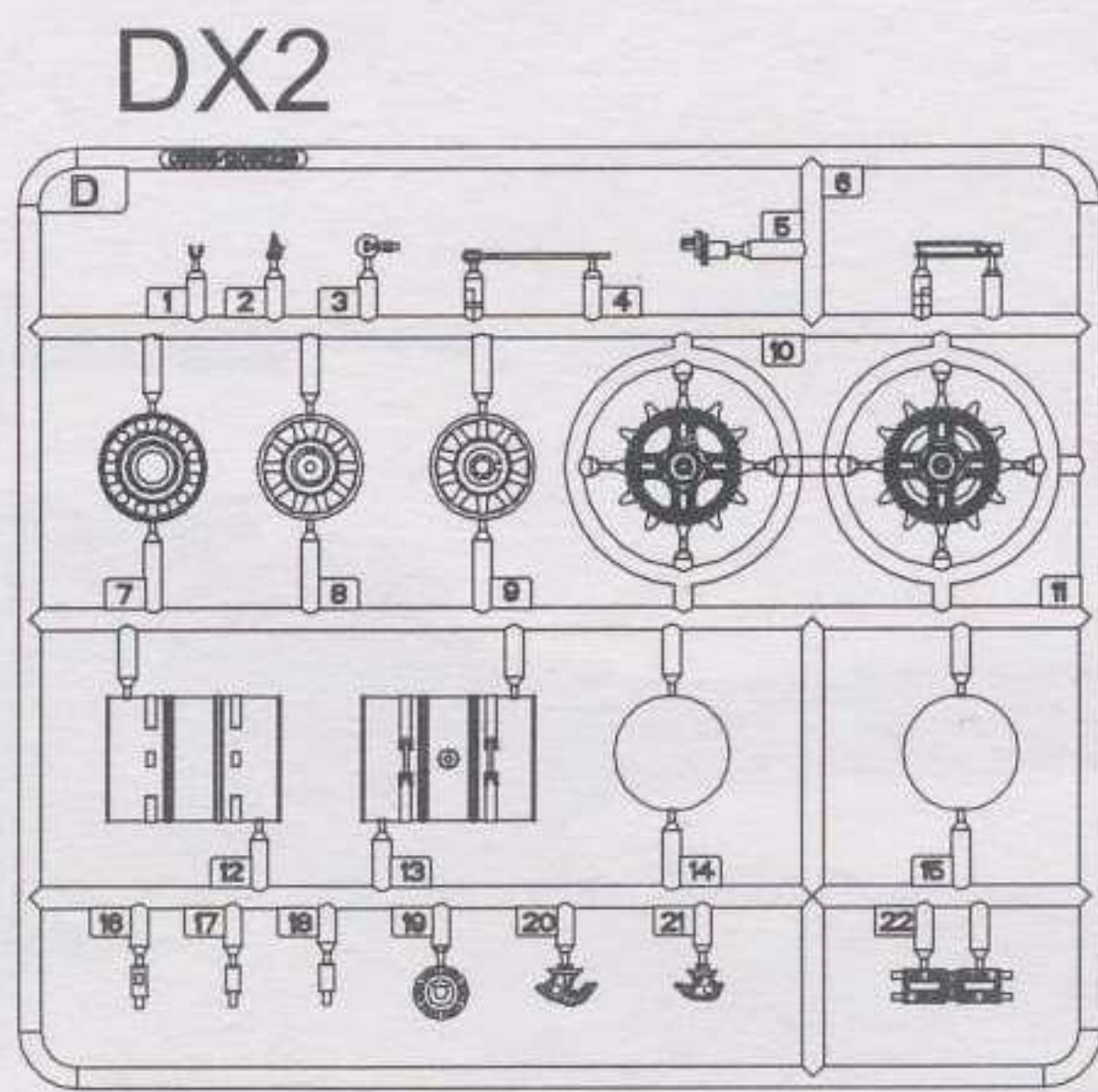
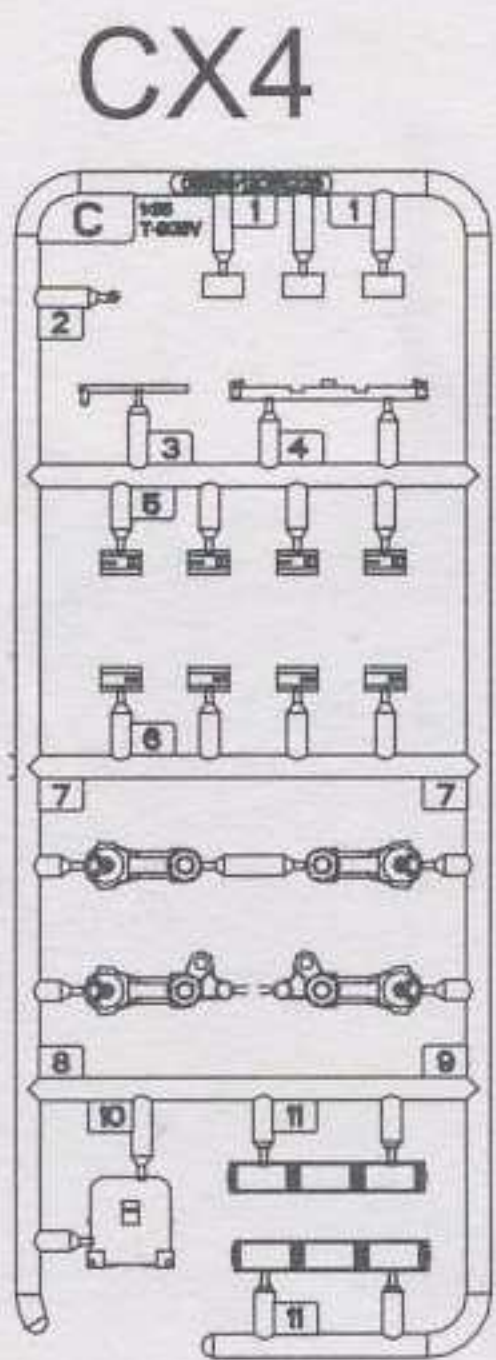
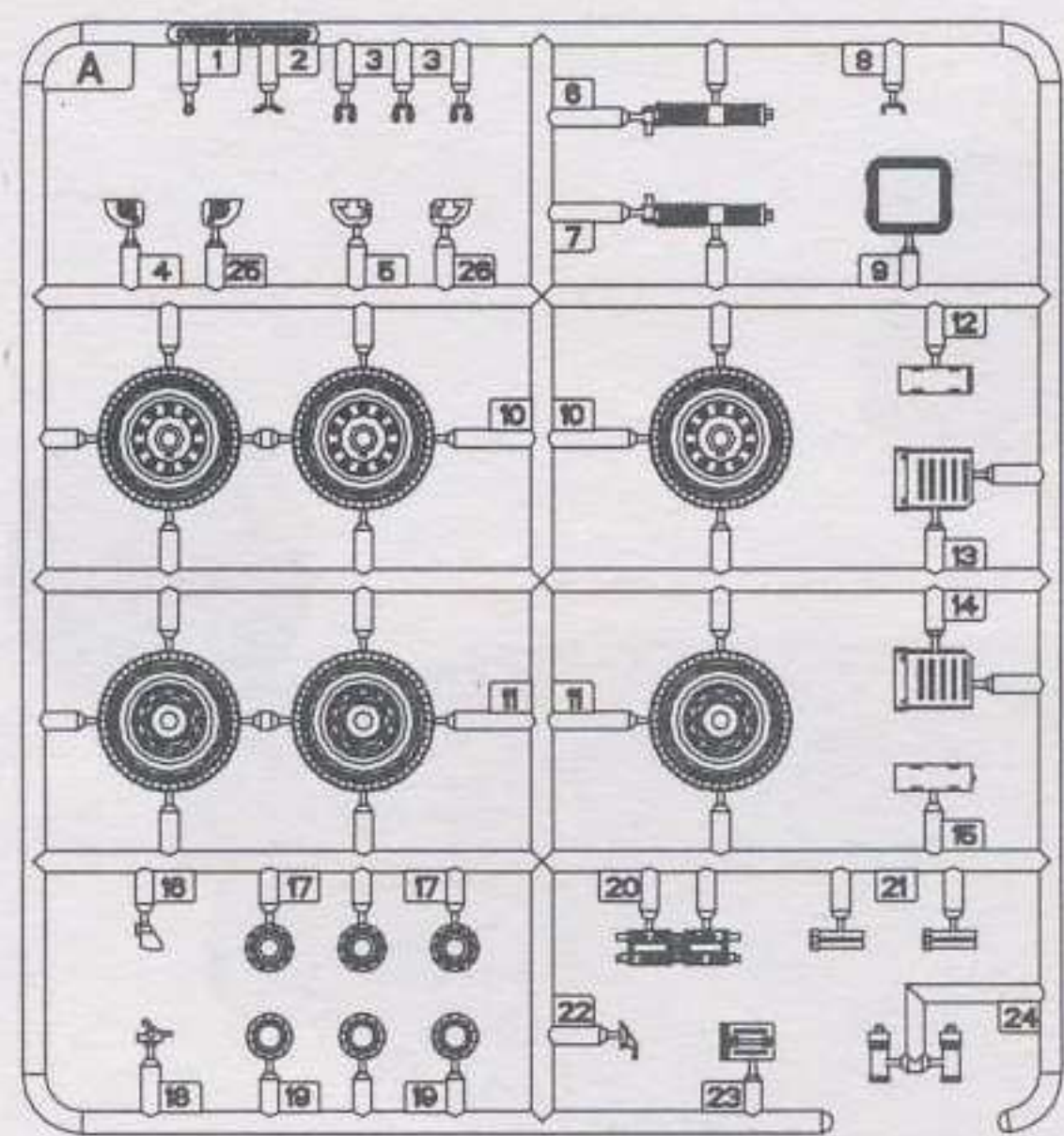

《铜缆》 $\varnothing 0.8 \times 240 \text{mm}$
Brass wire

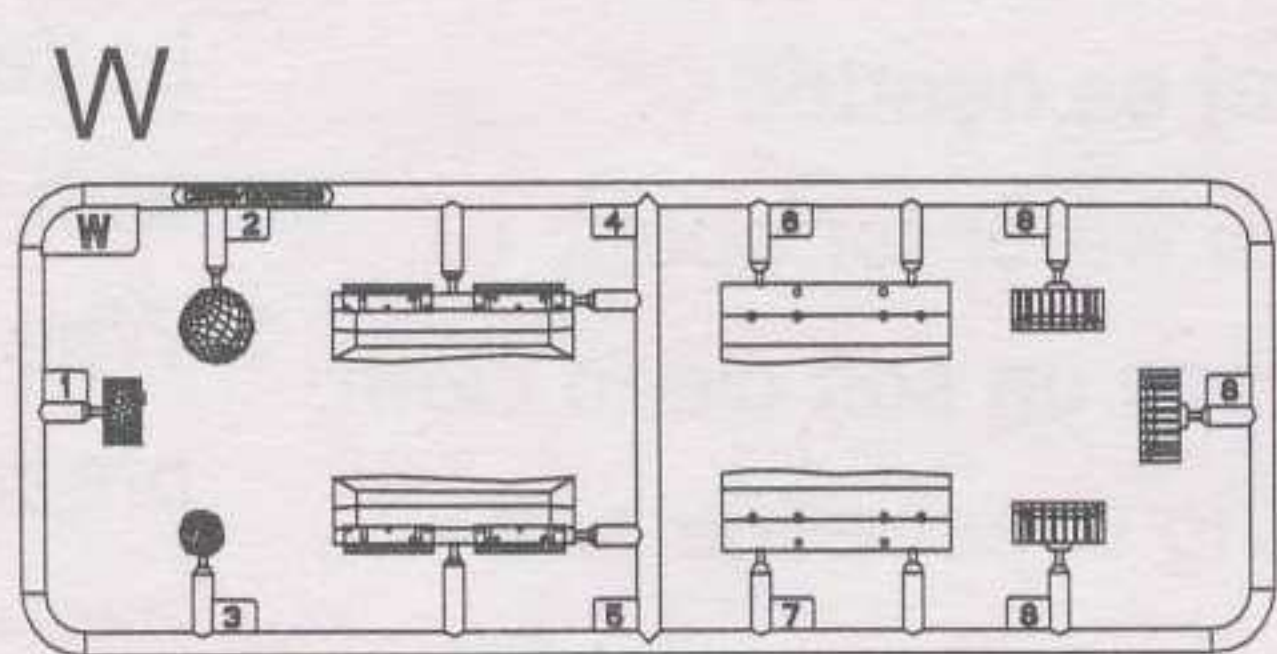
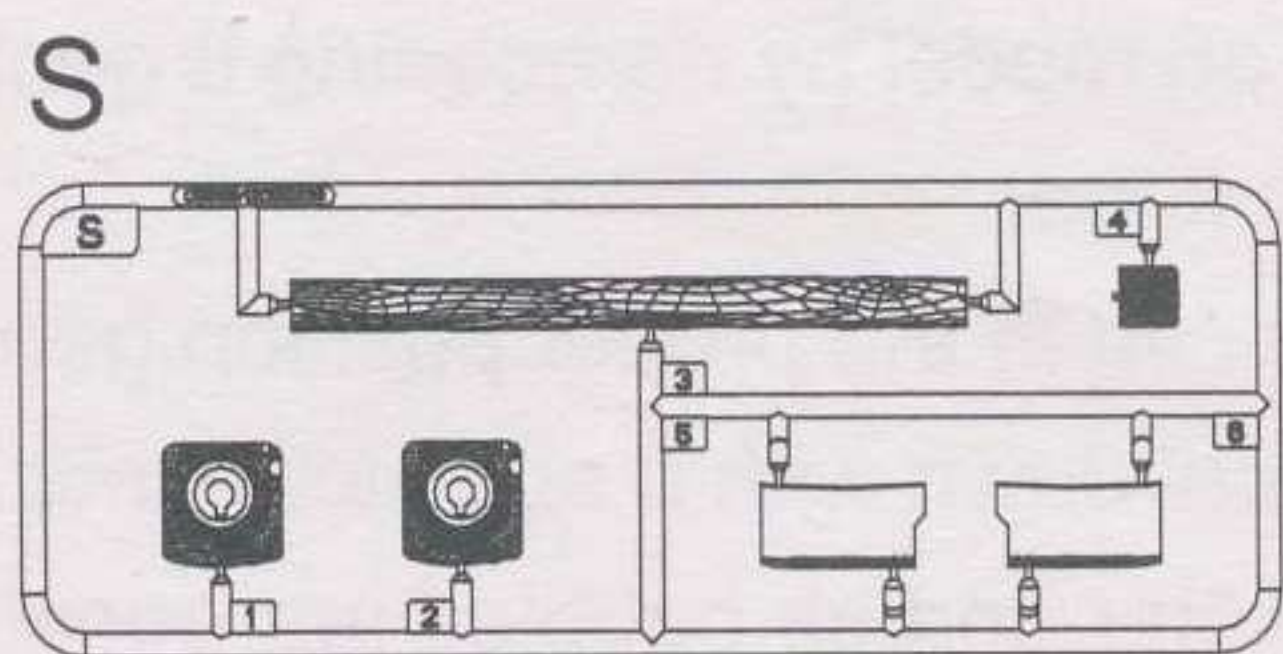
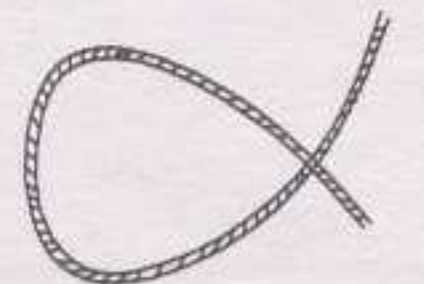

《蚀刻片》
PE-A

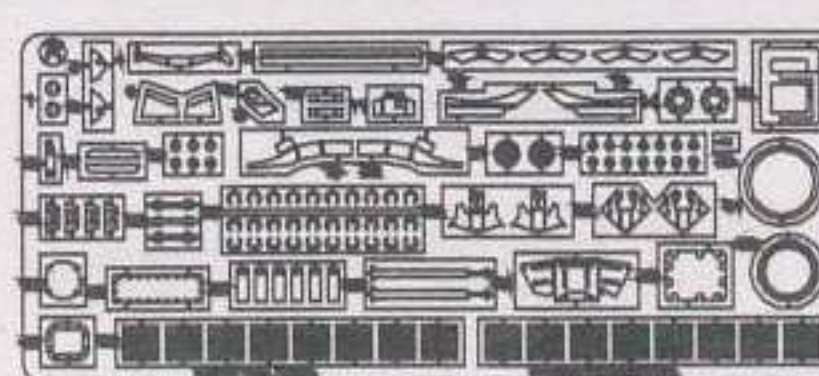

《蚀刻片》
PE-B

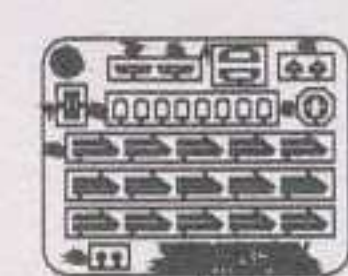

《水贴》
Decal



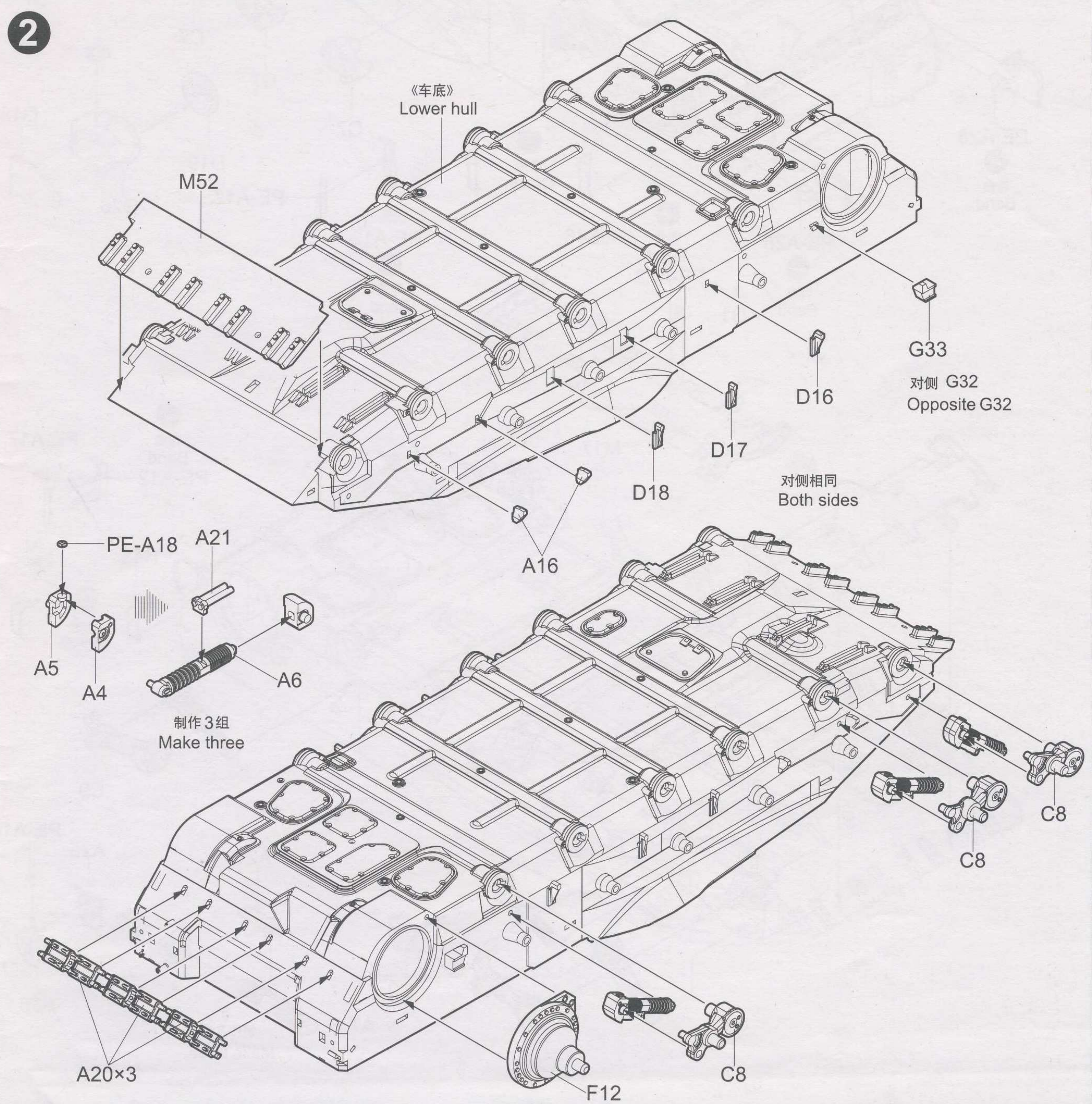
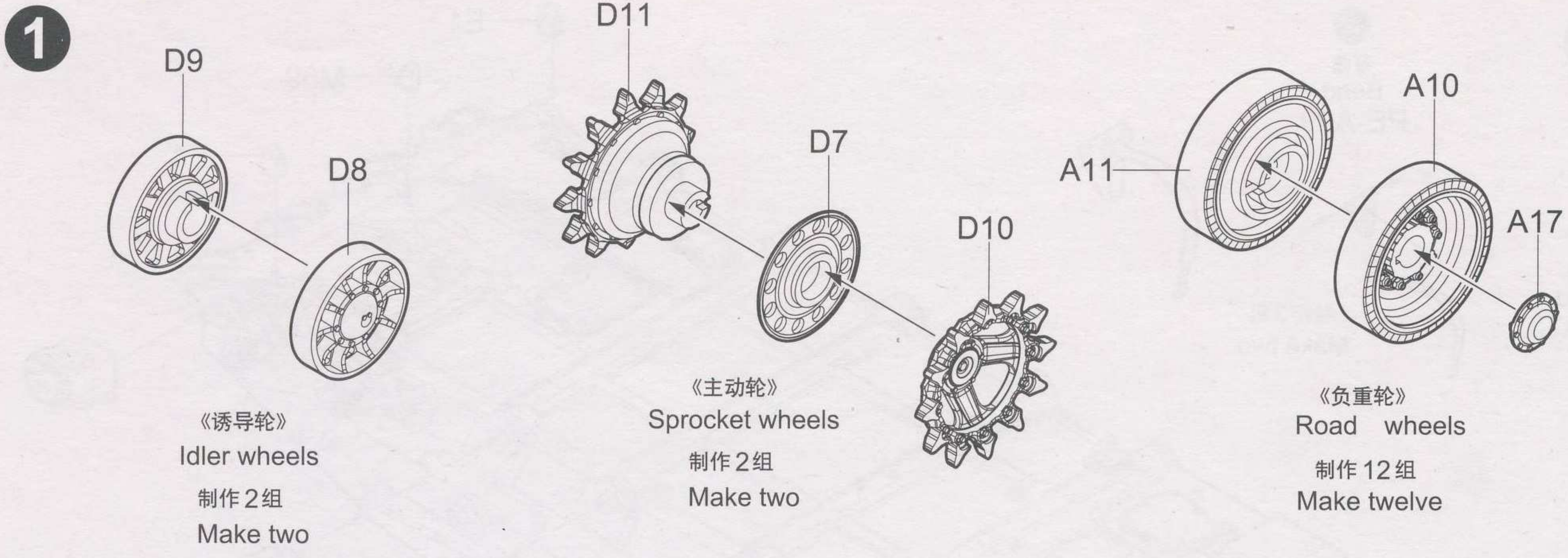

3

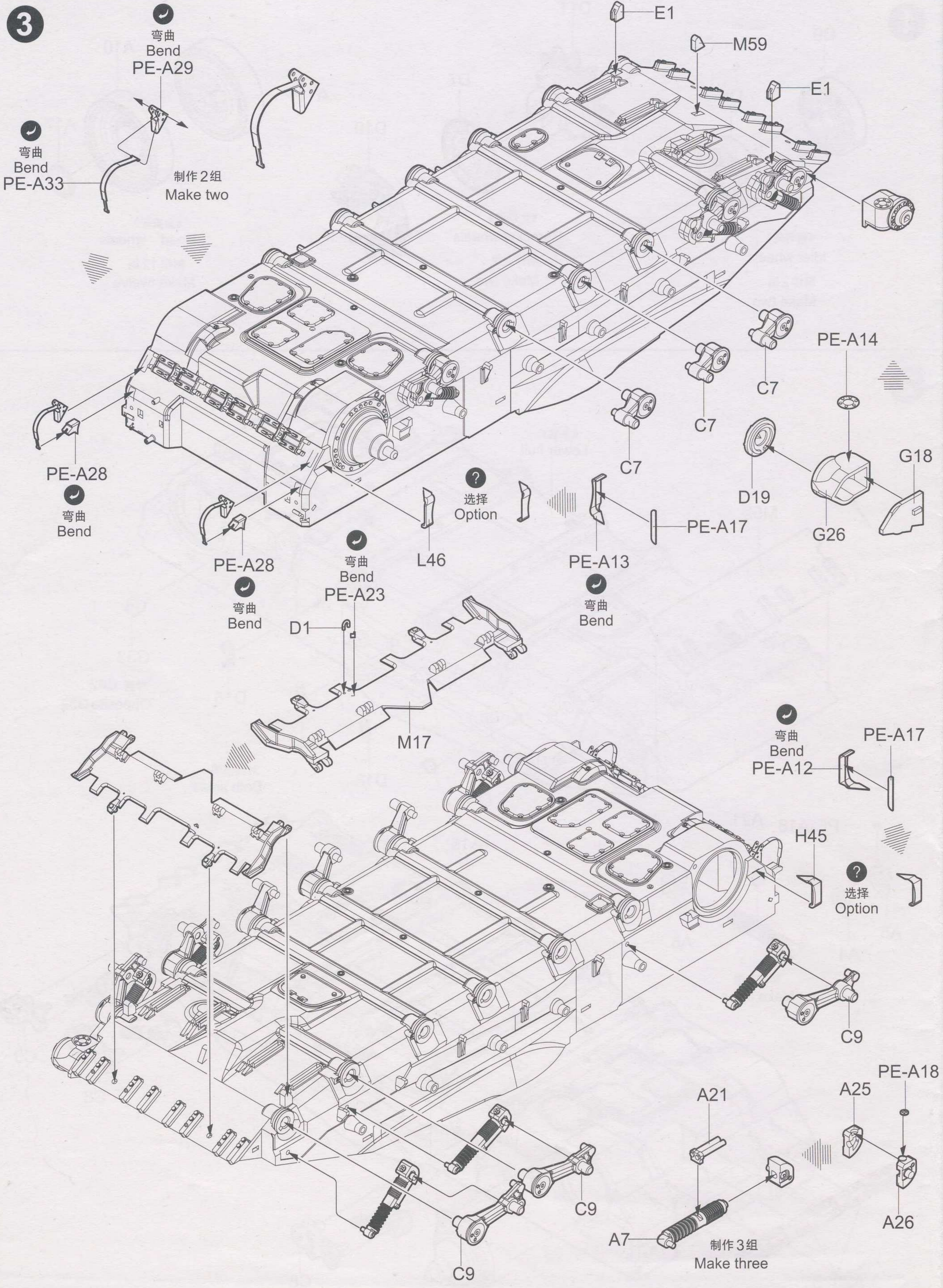

4

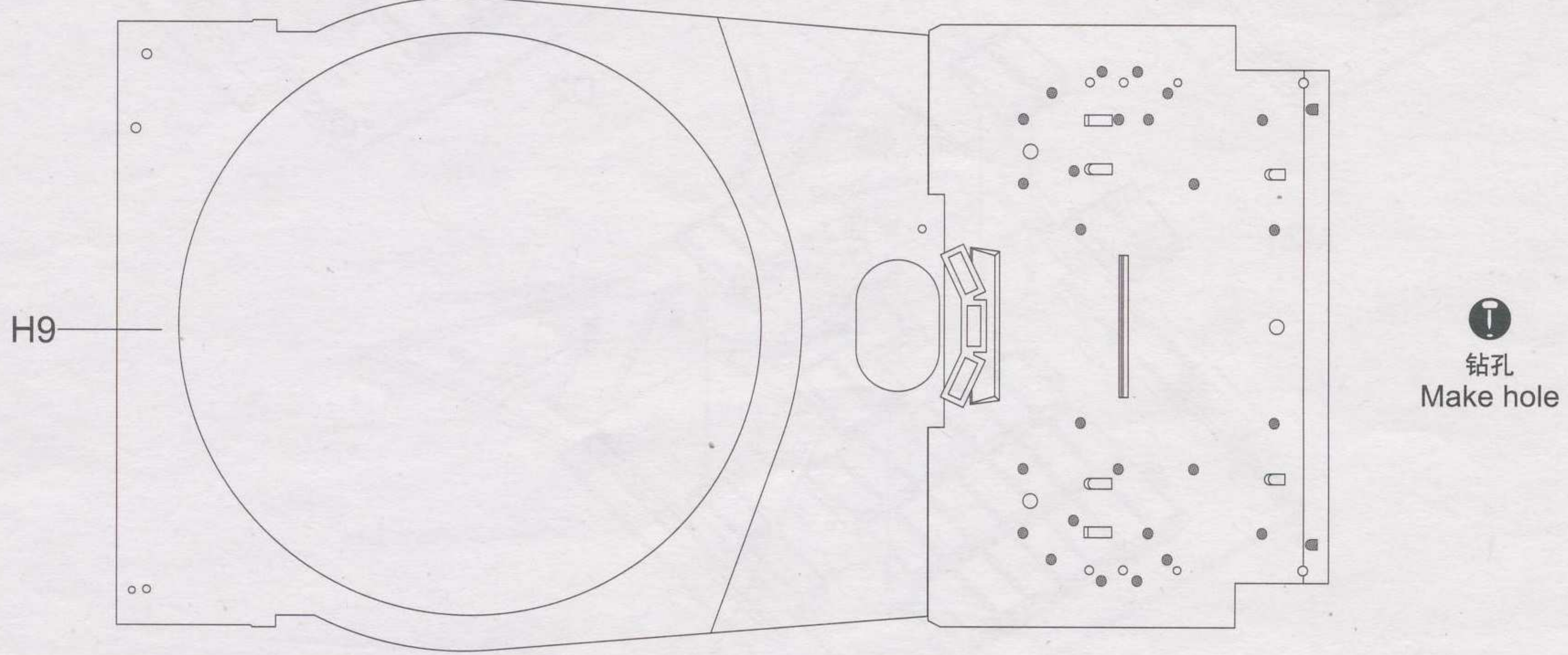
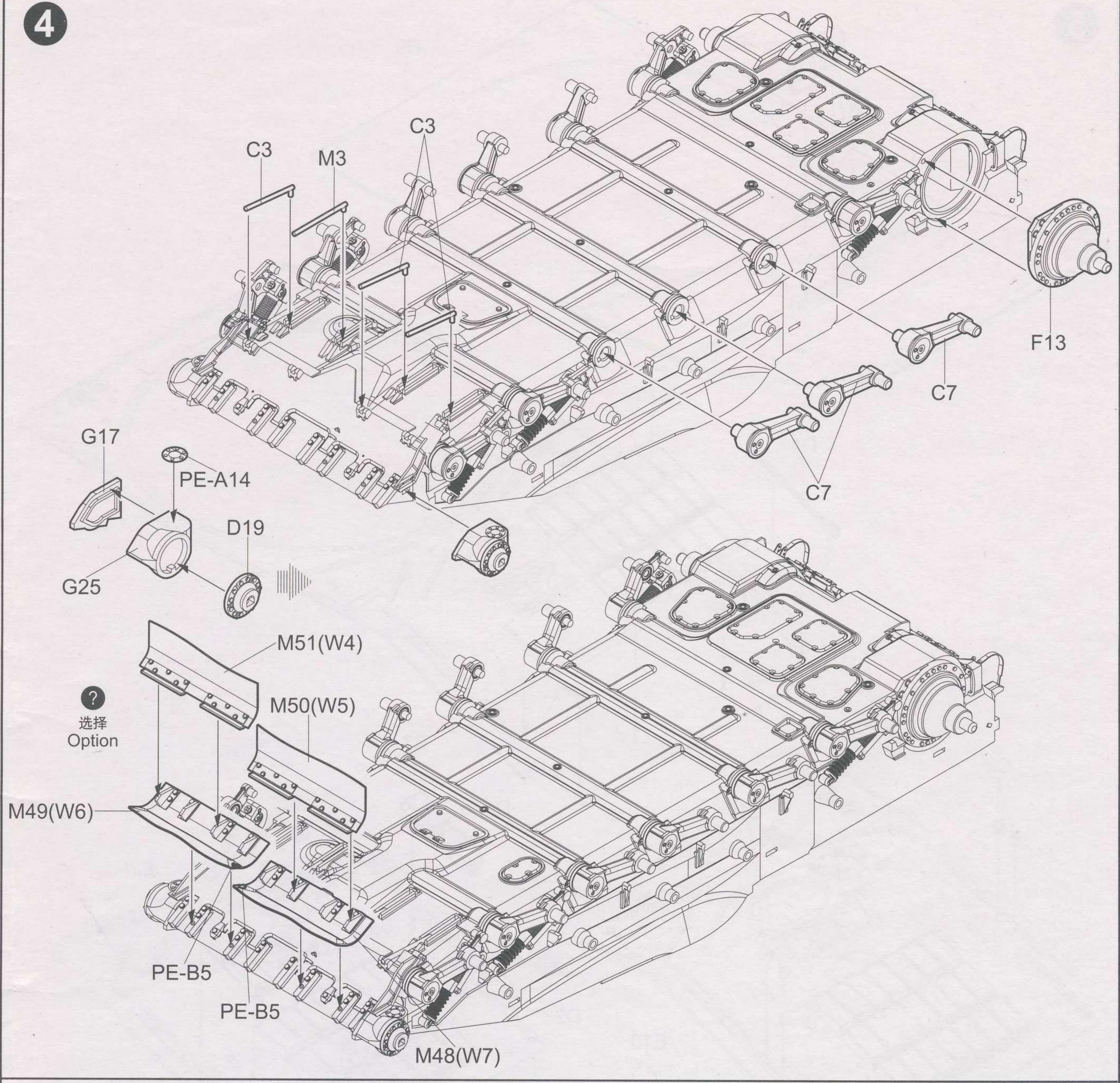

5

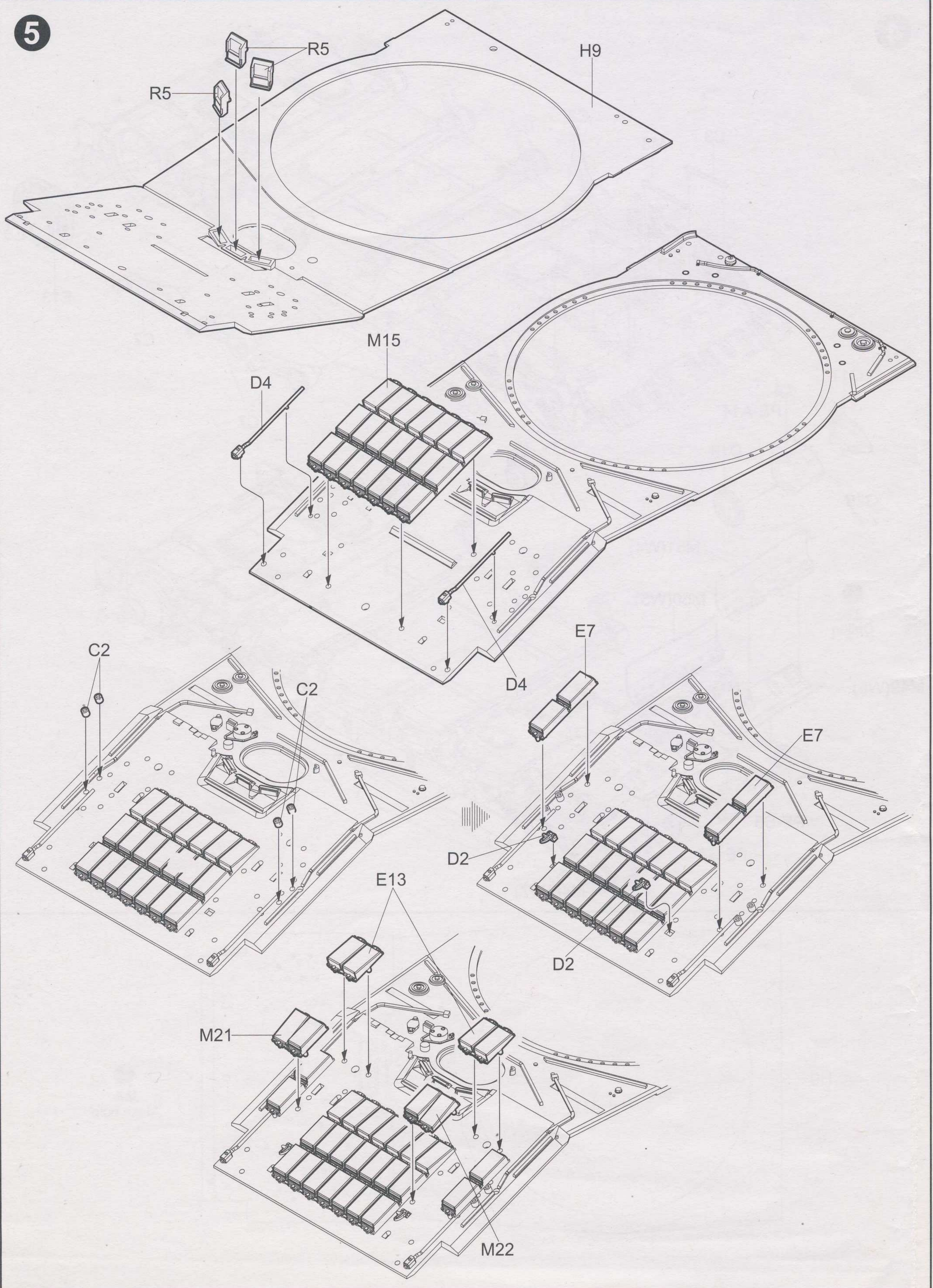

6

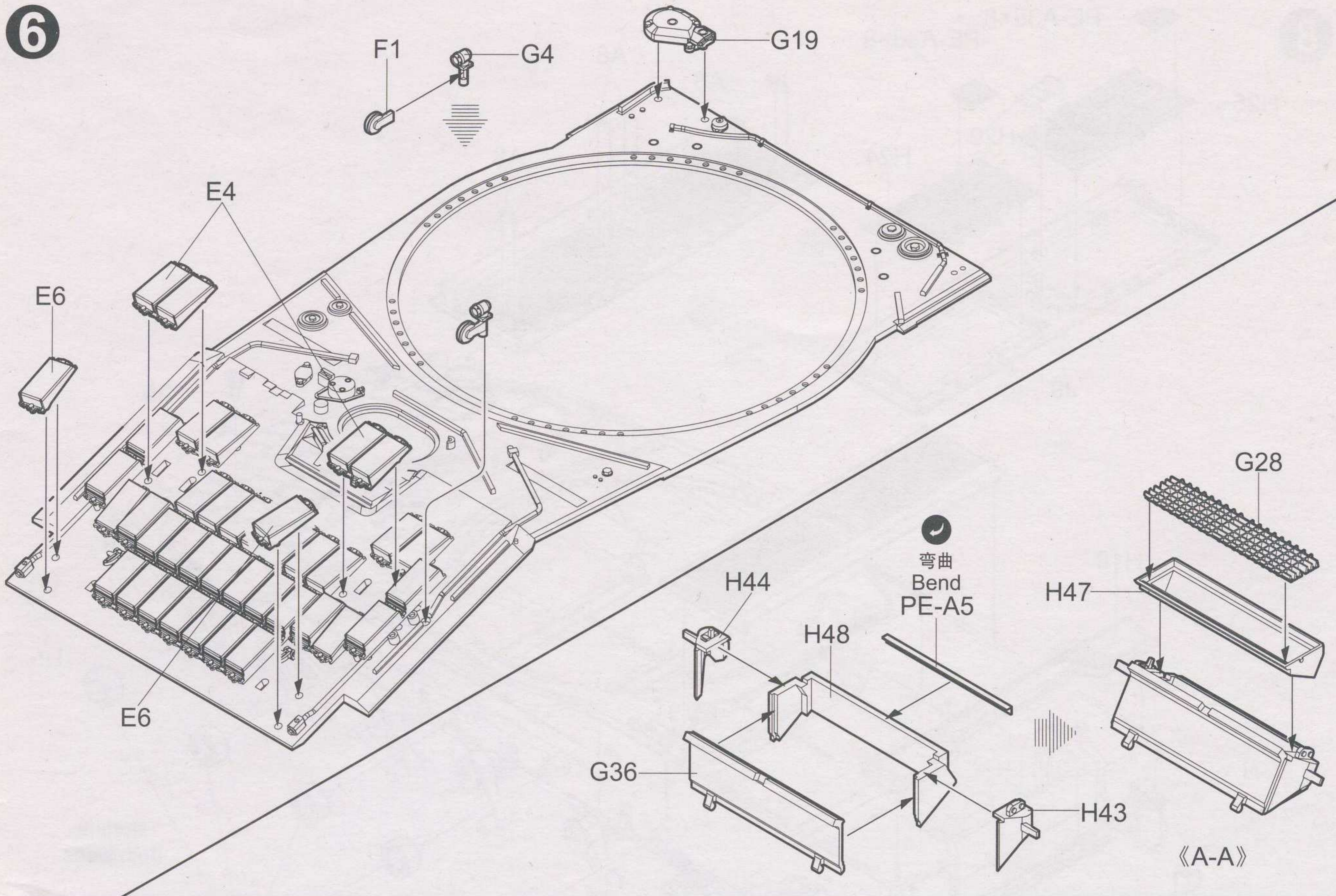

7

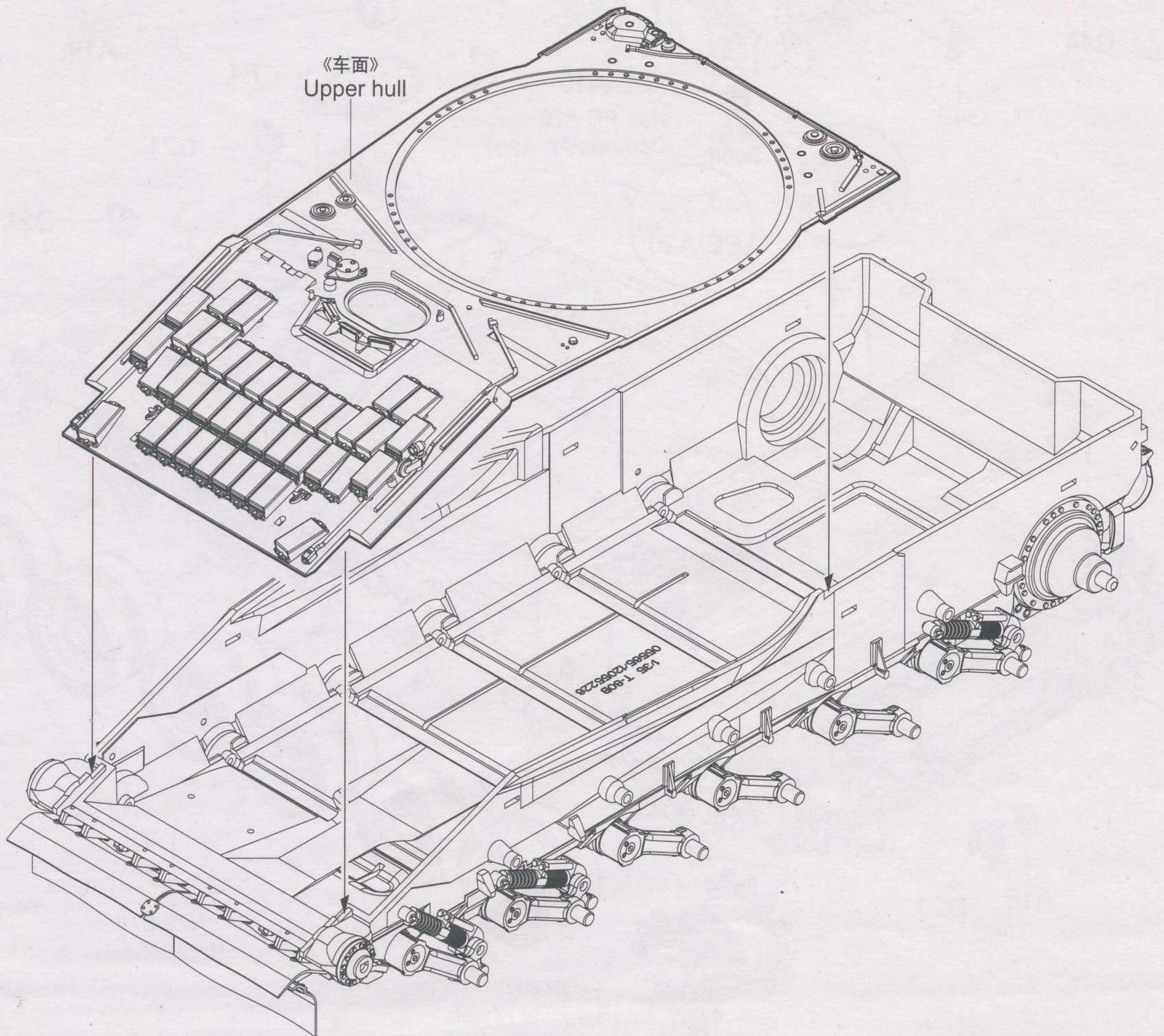

8

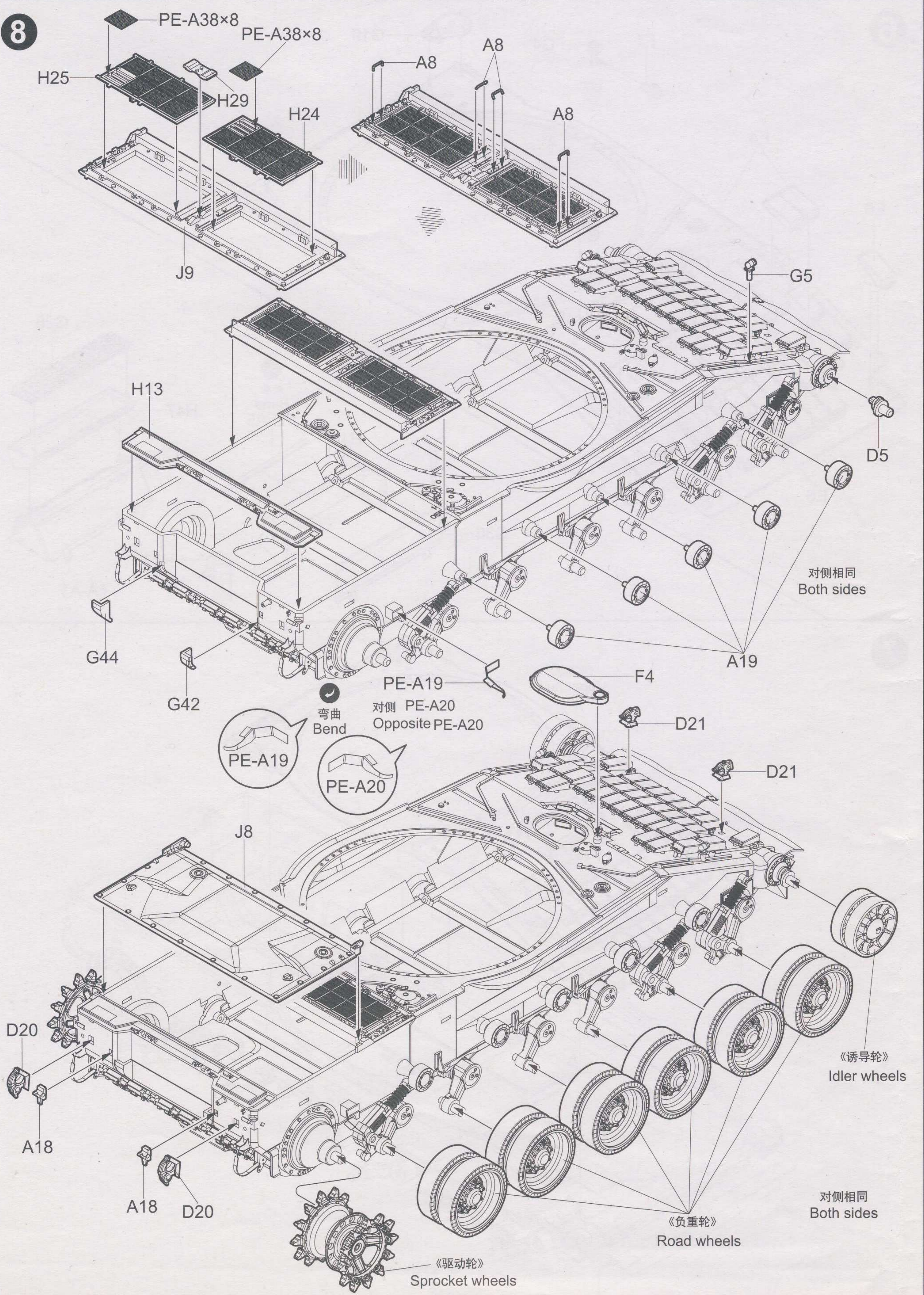

9

单侧履带需要80节
Complete track for one side requires 80 links.

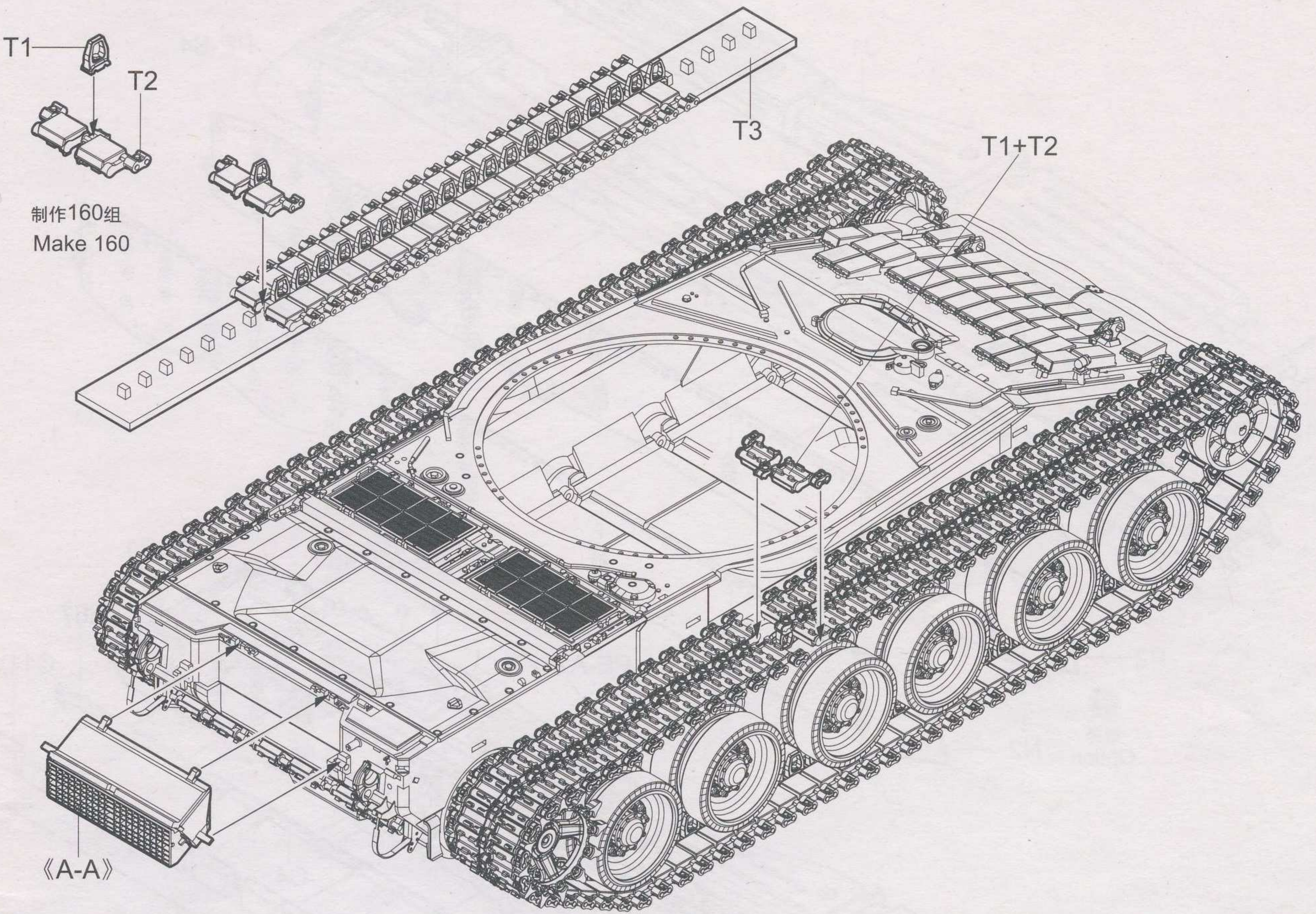

10

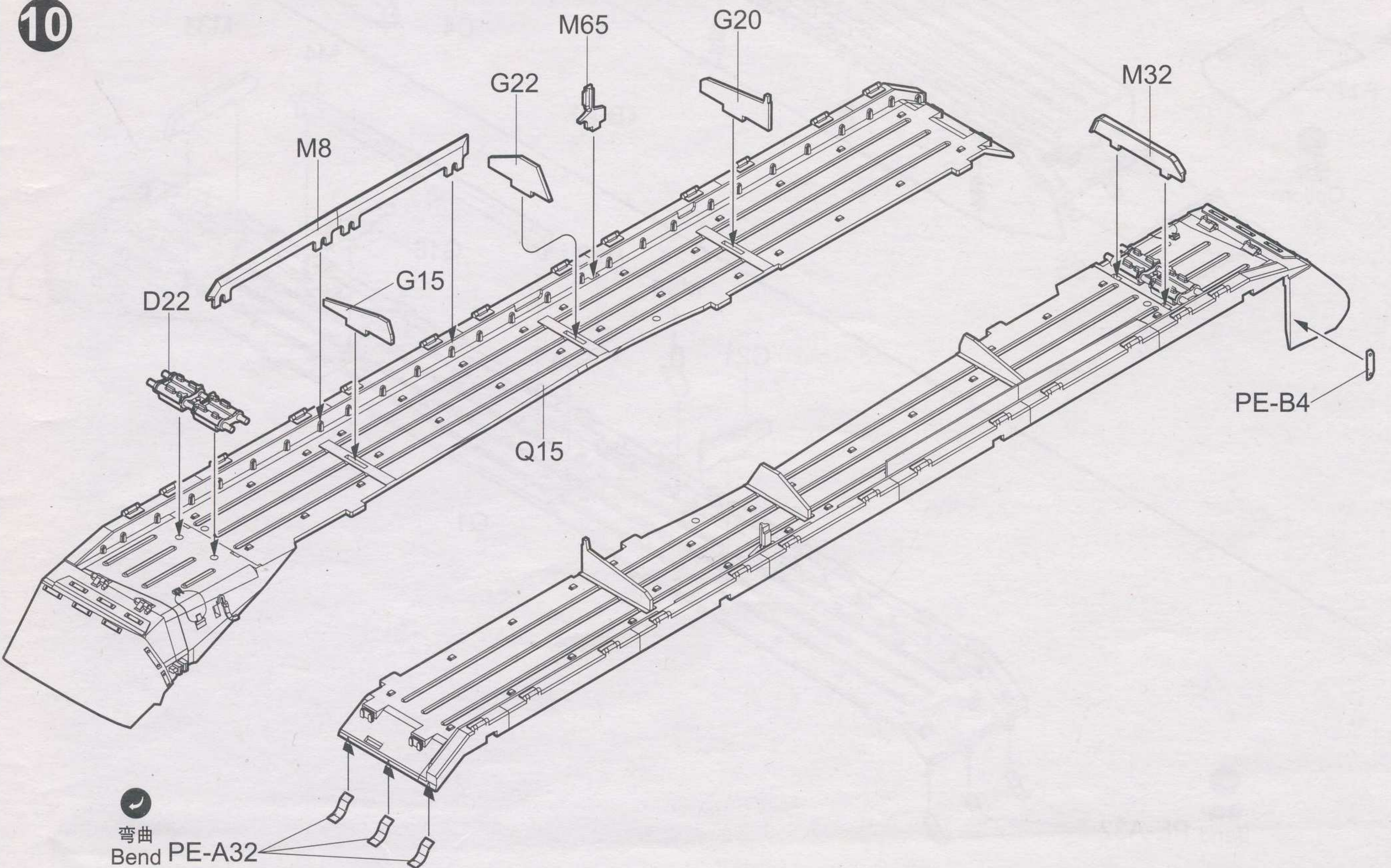

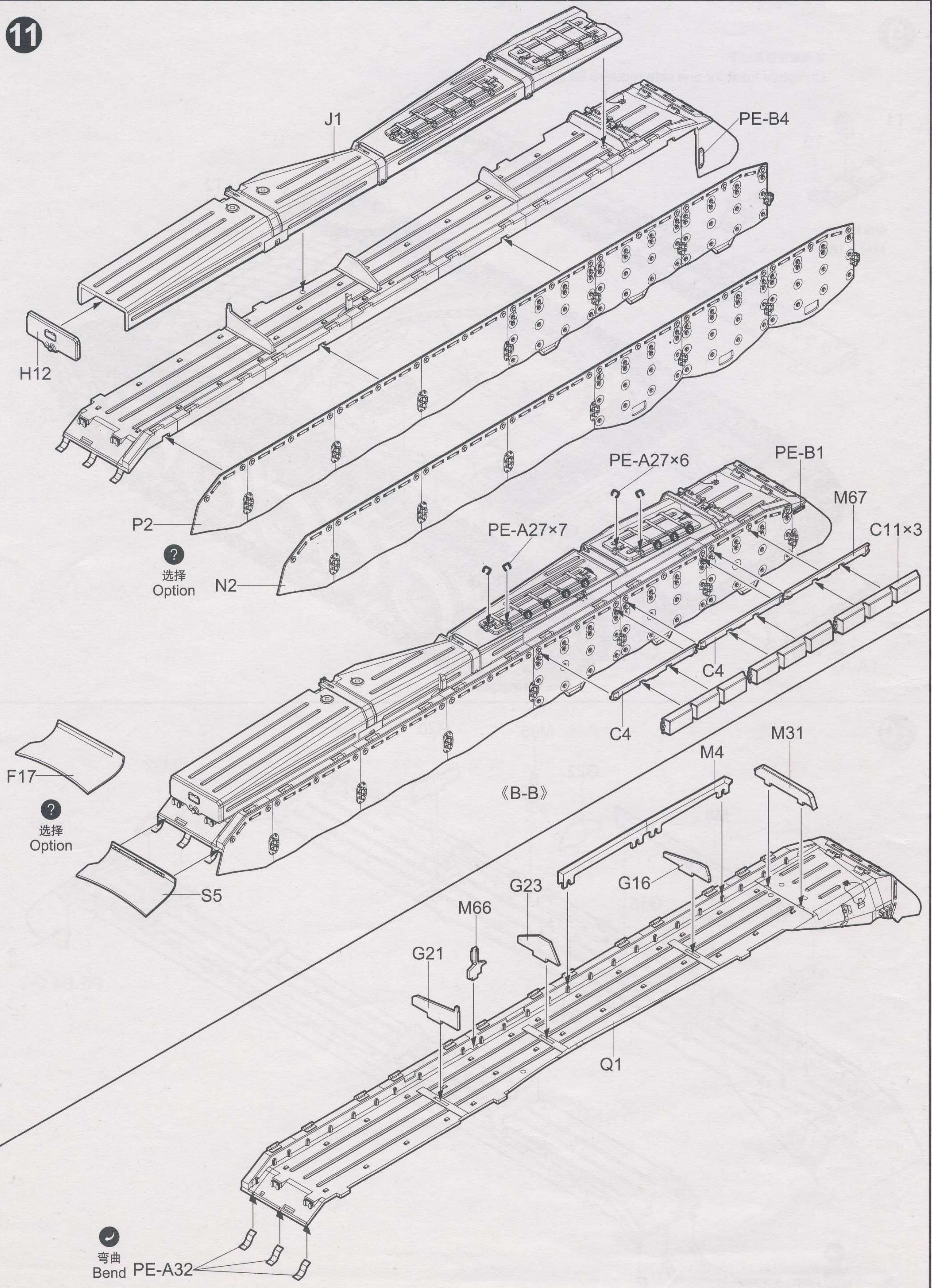

12

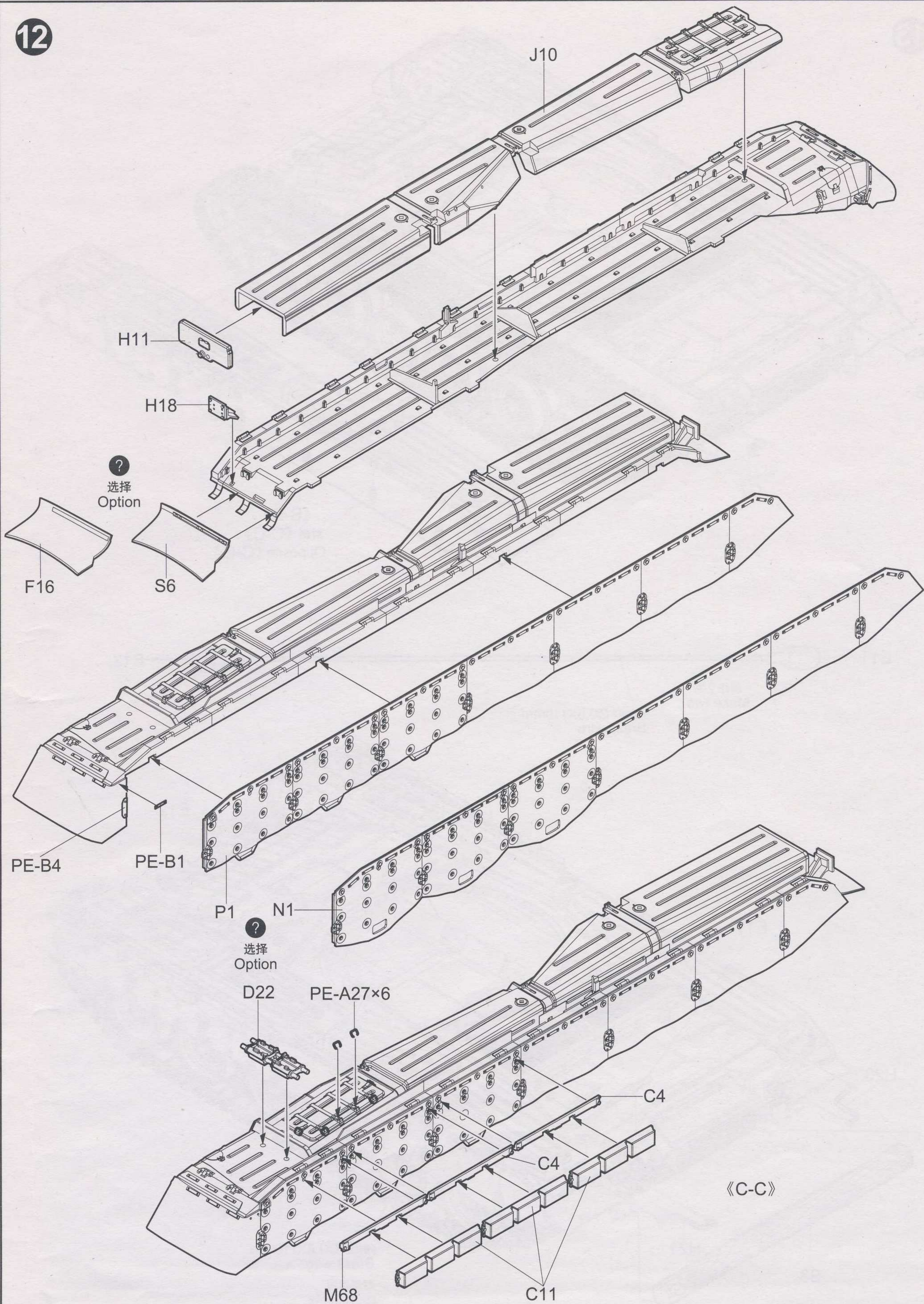

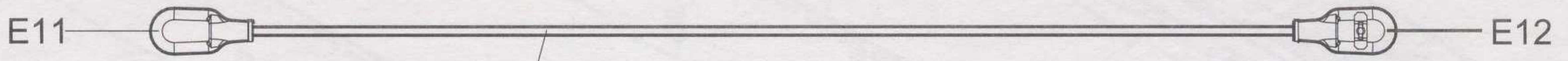
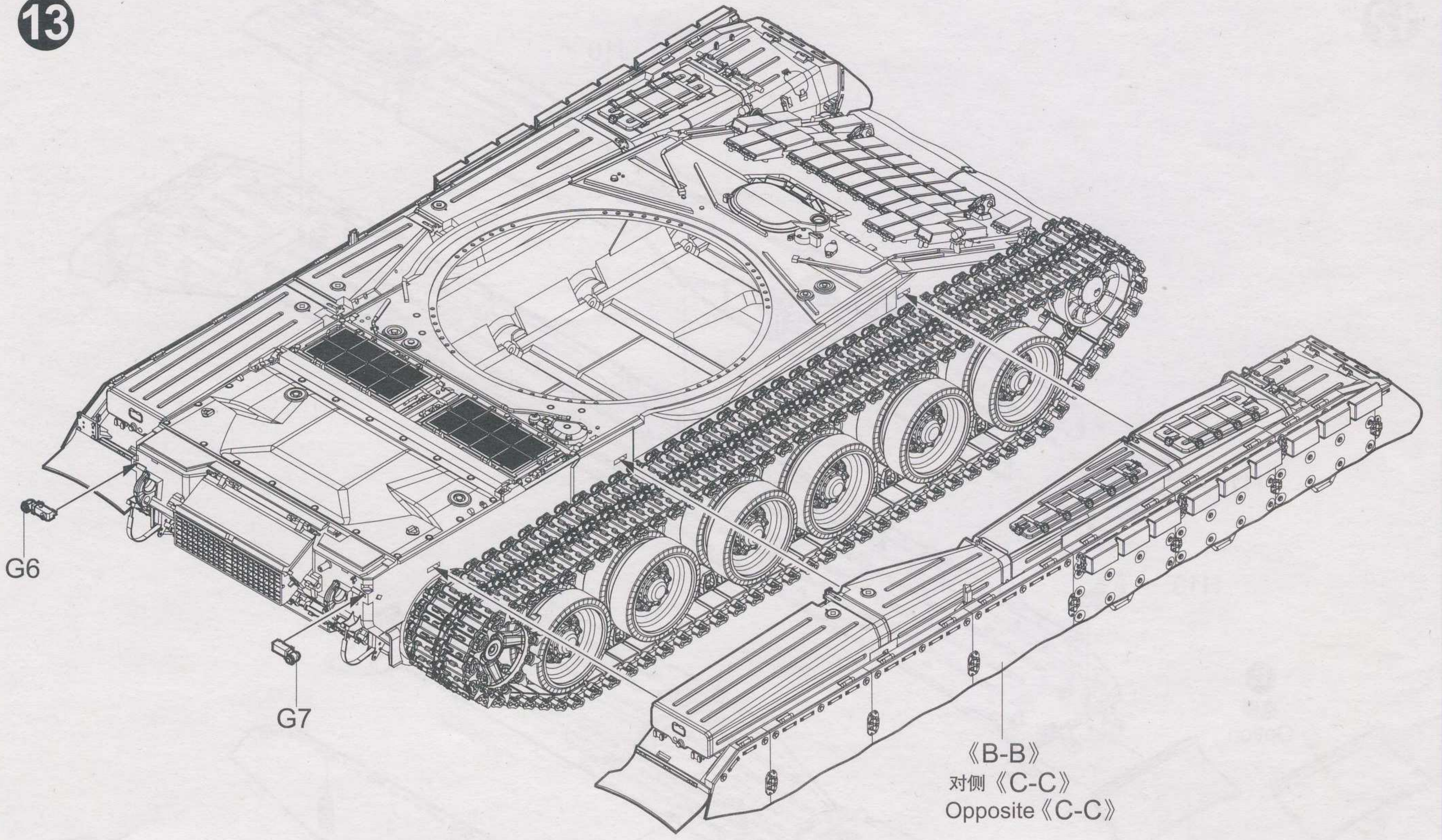

制作2组
Make two

《铜缆》 $\varnothing 0.8 \times 110 \text{mm}$
Brass wire

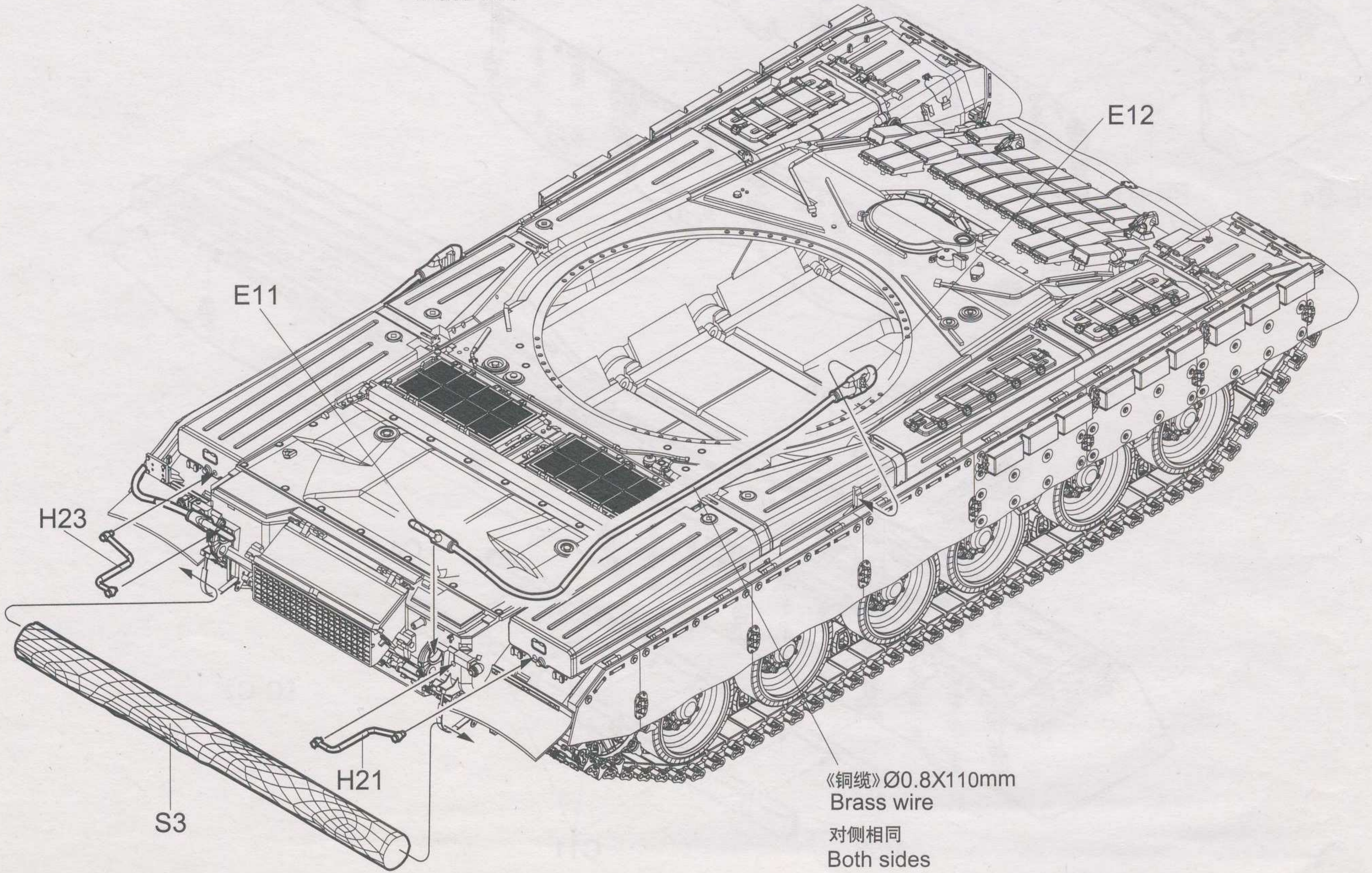

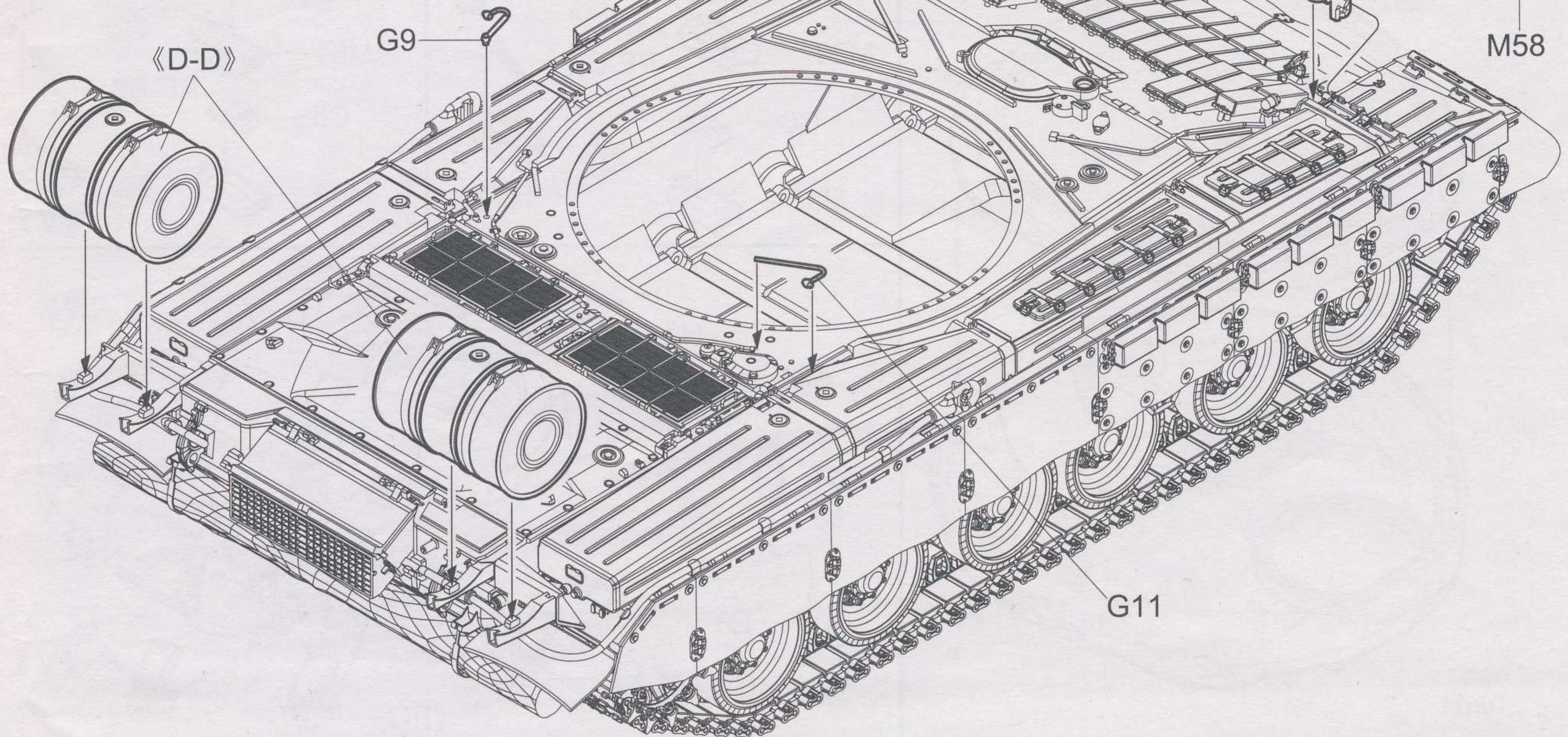
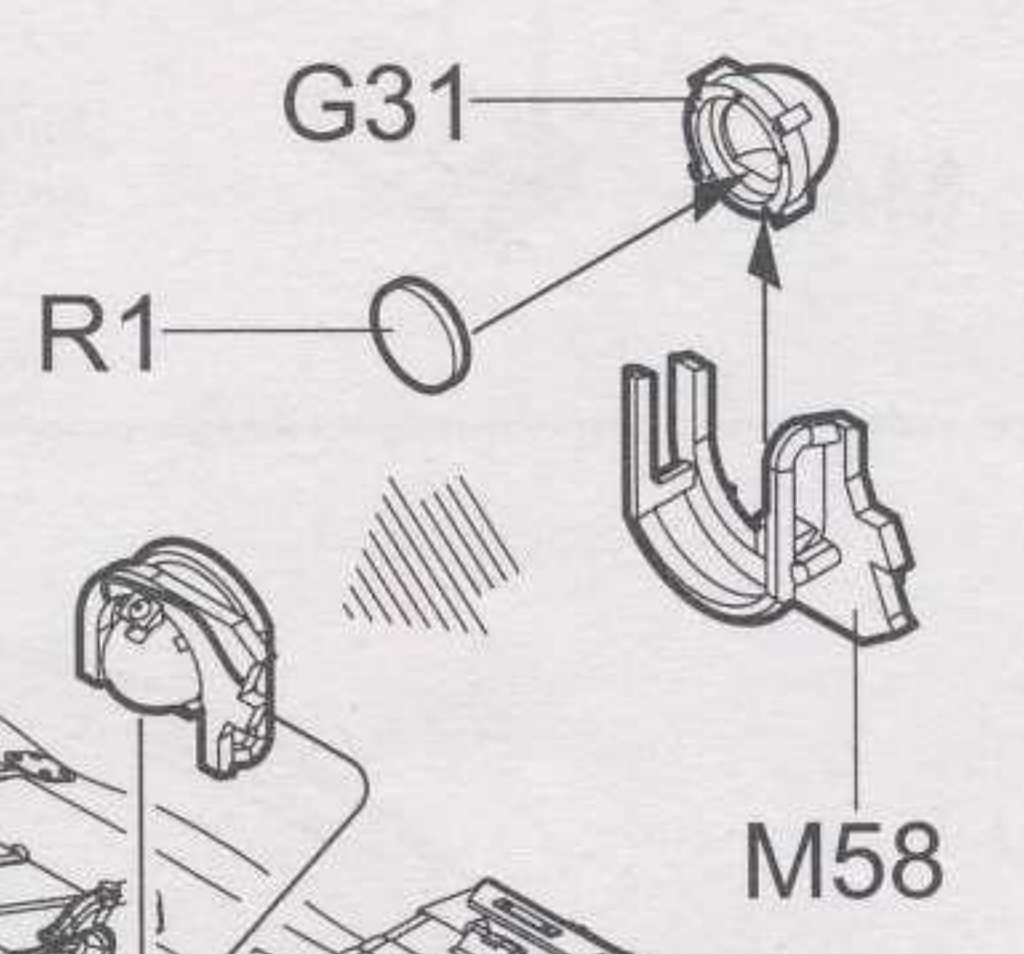
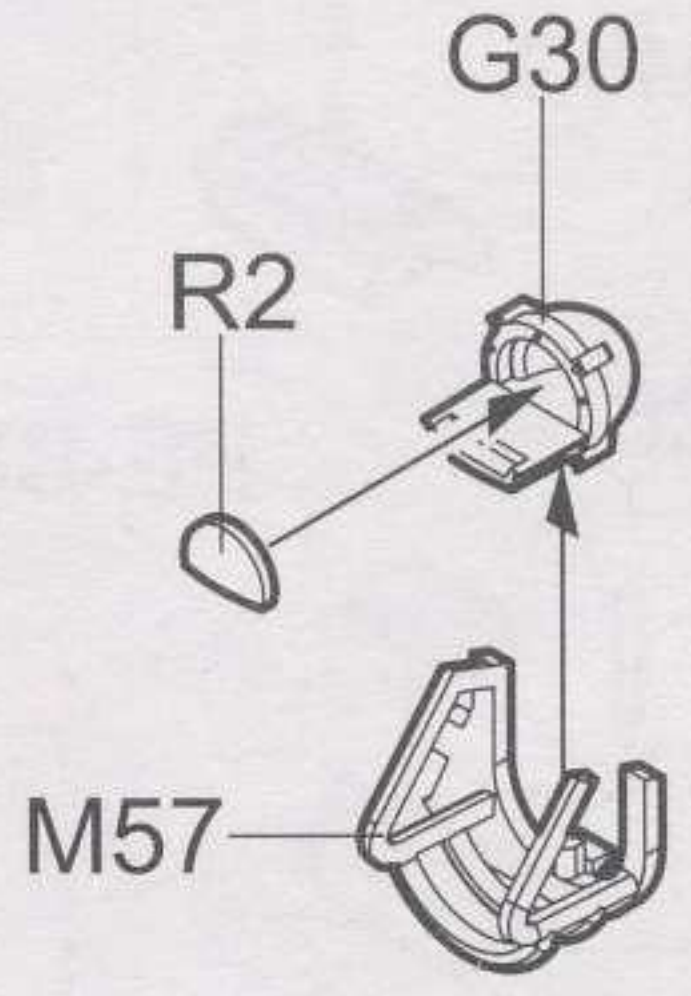
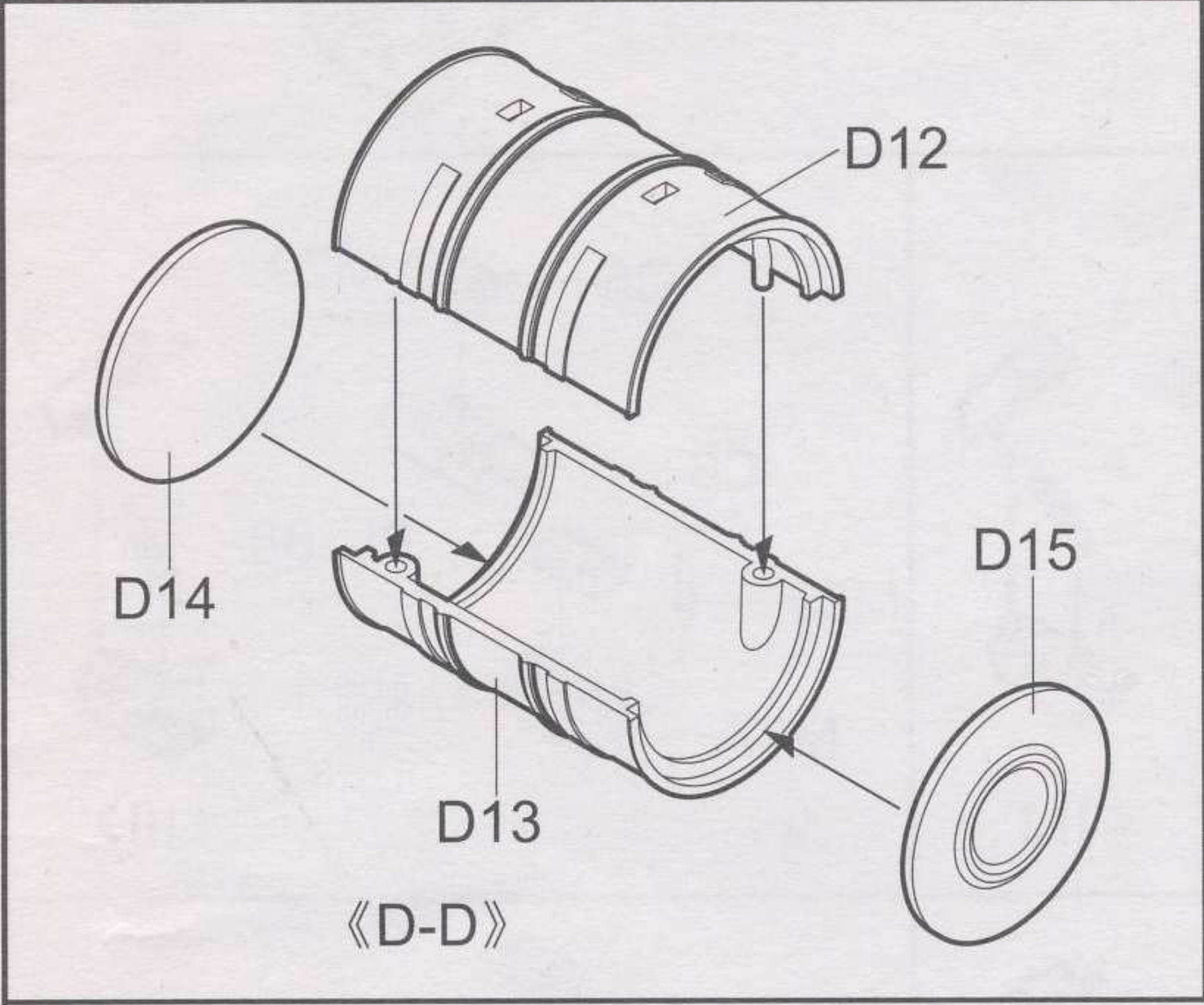
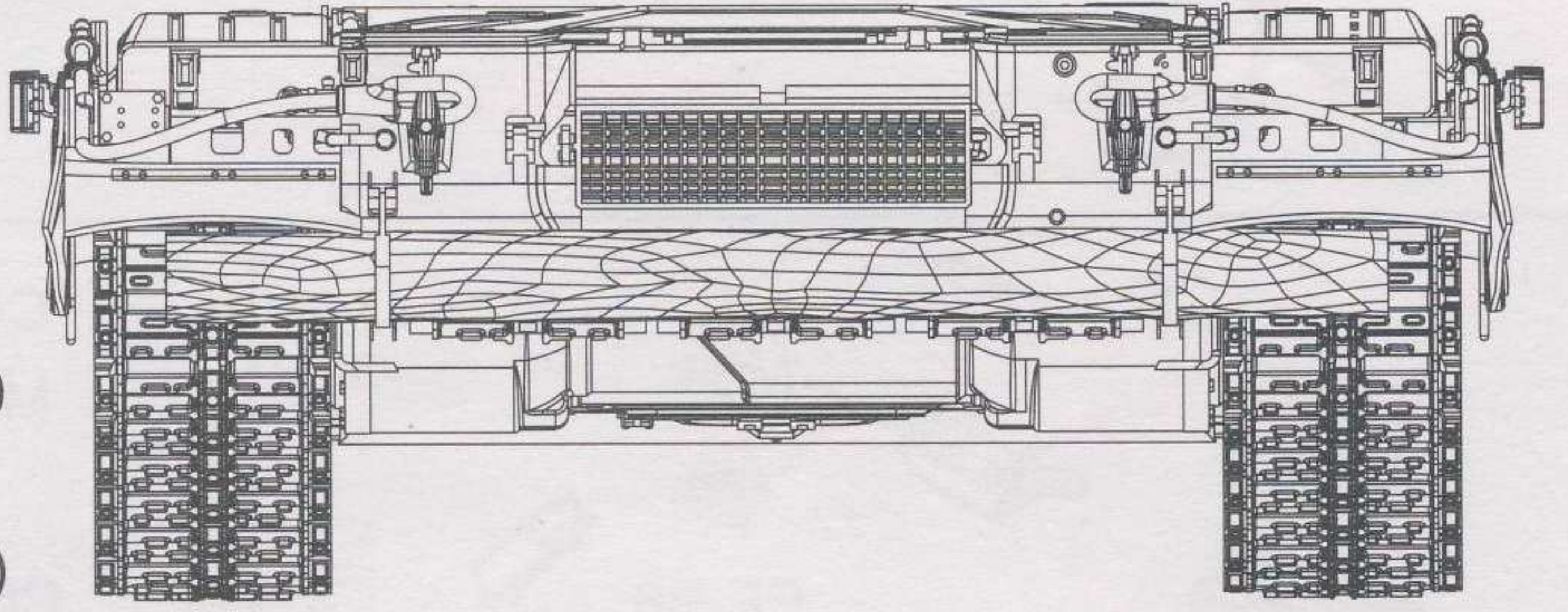
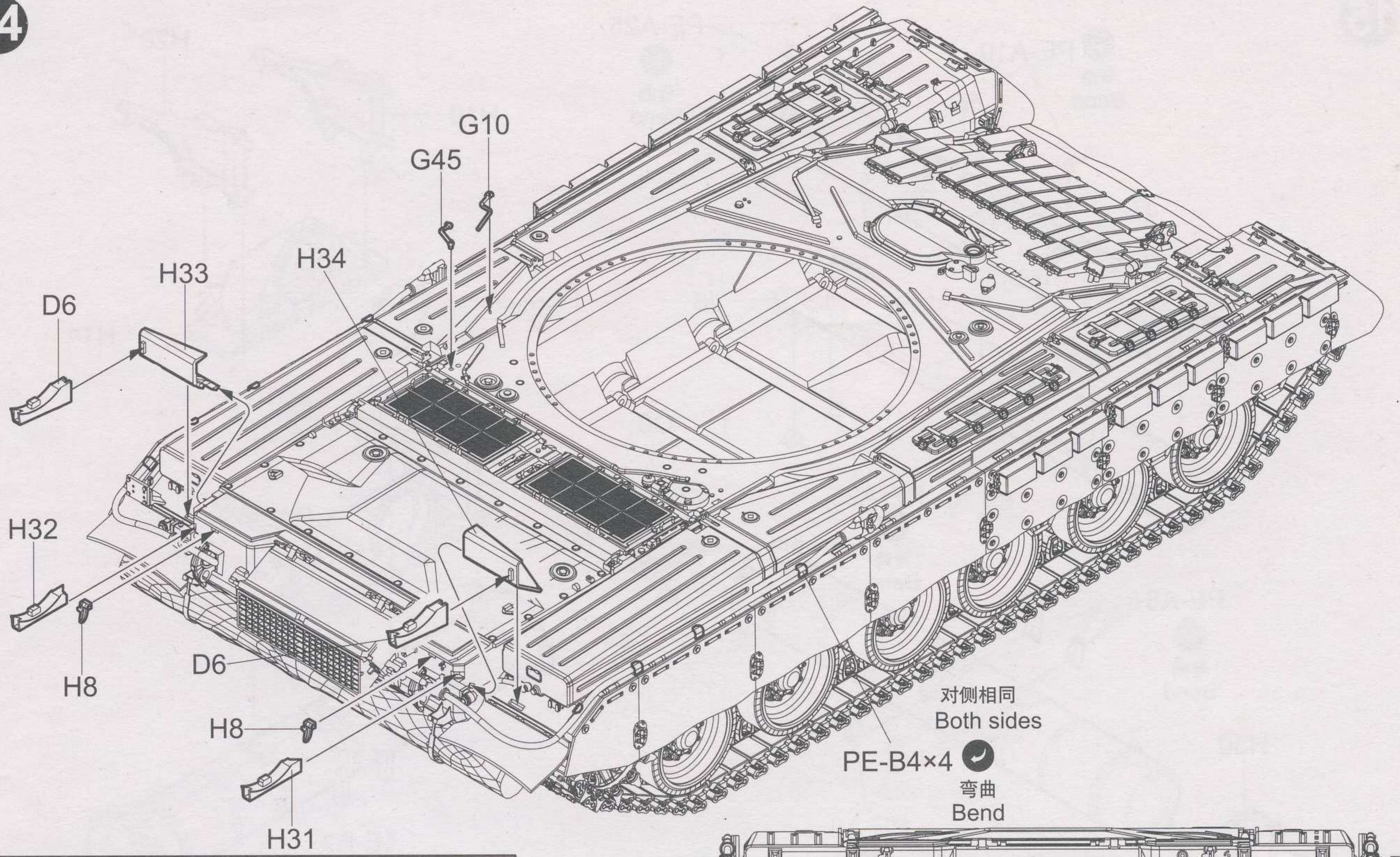

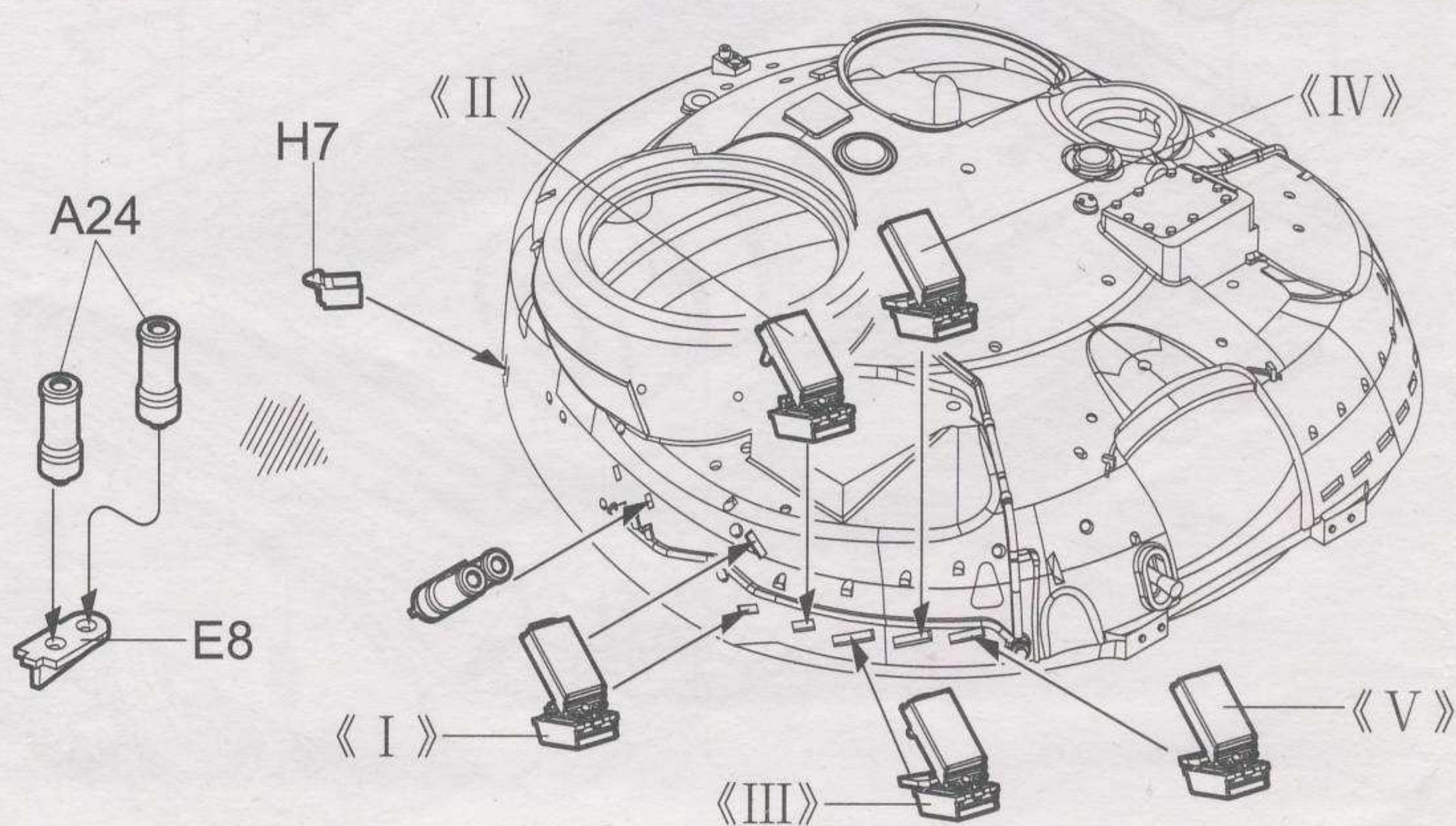
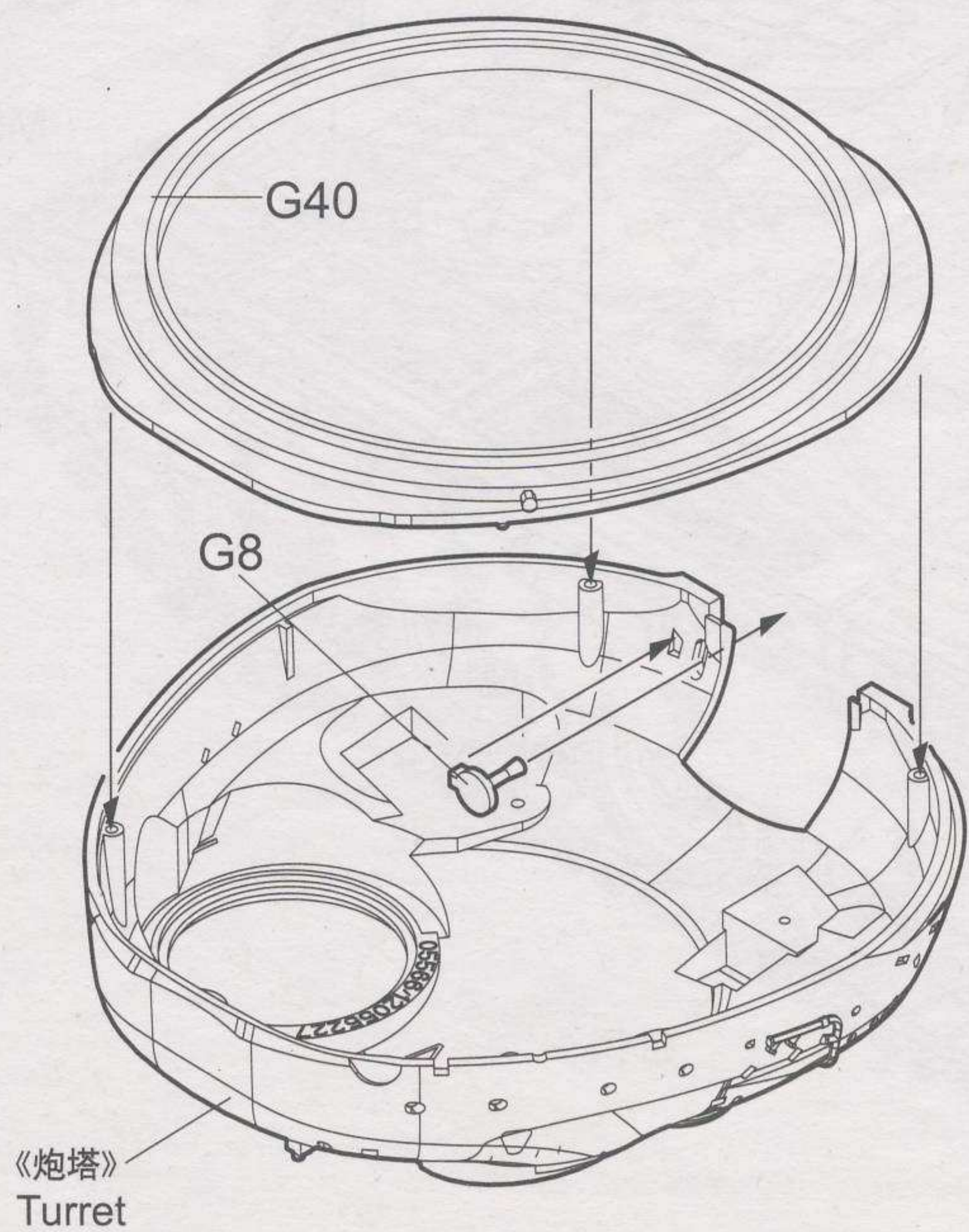
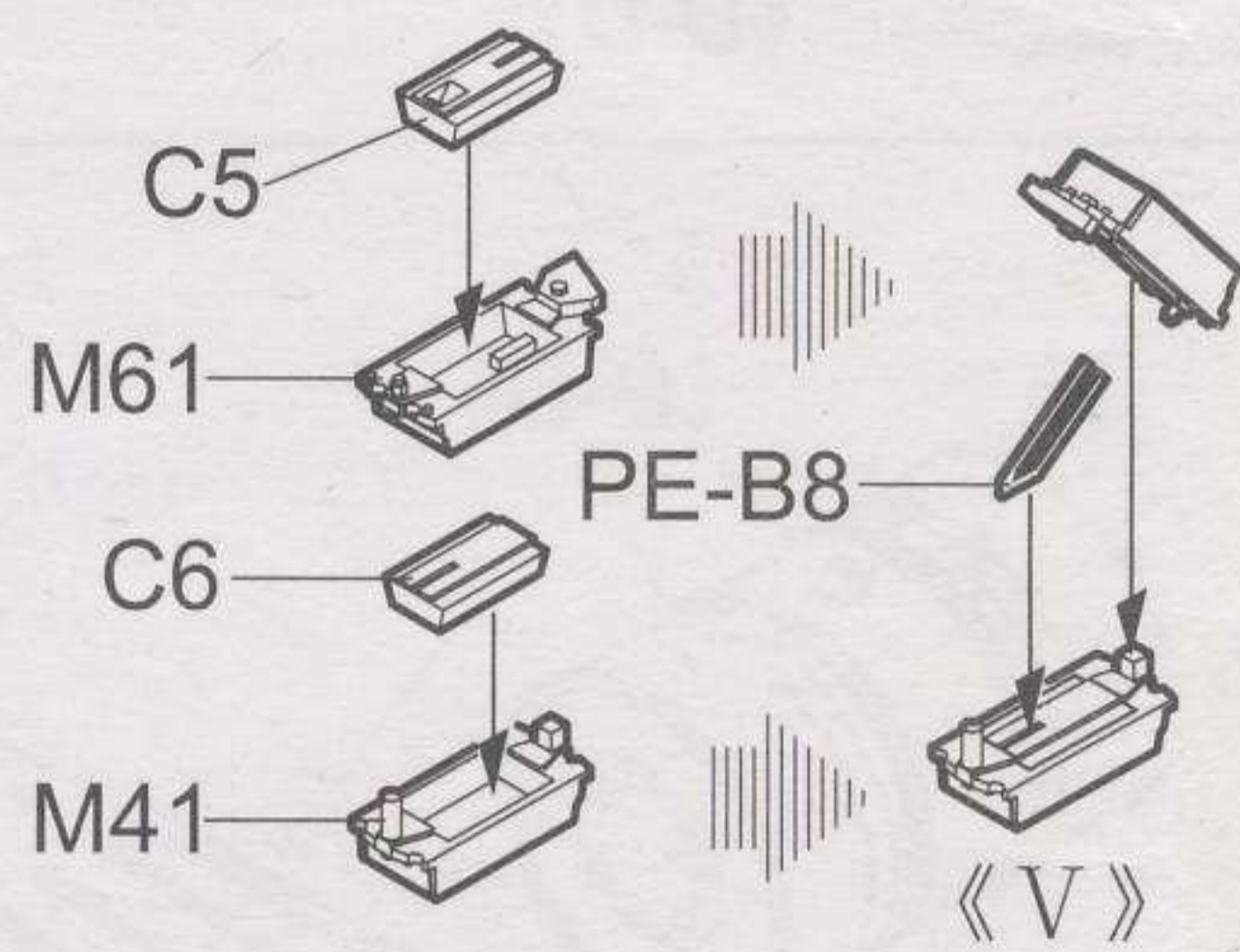
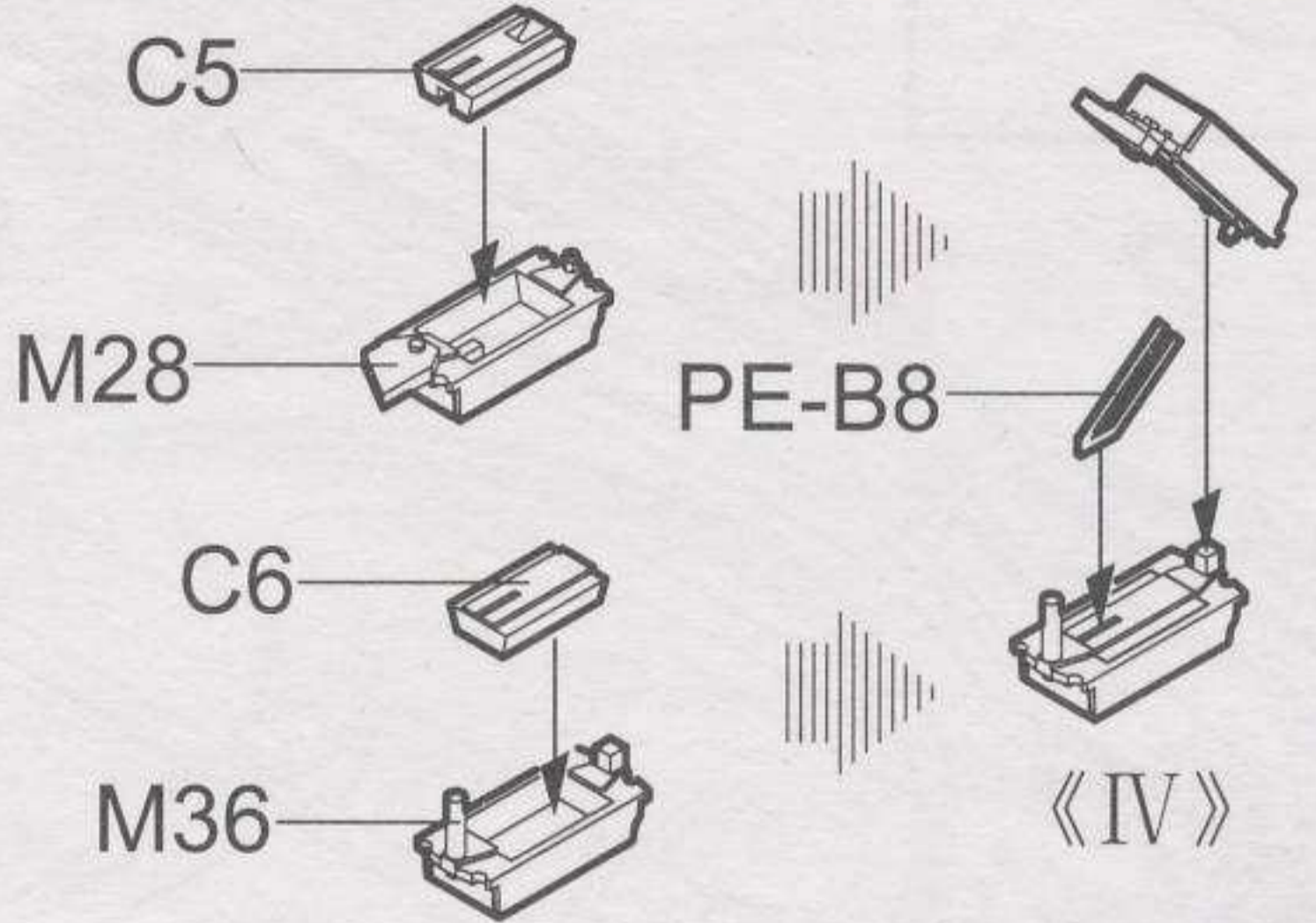
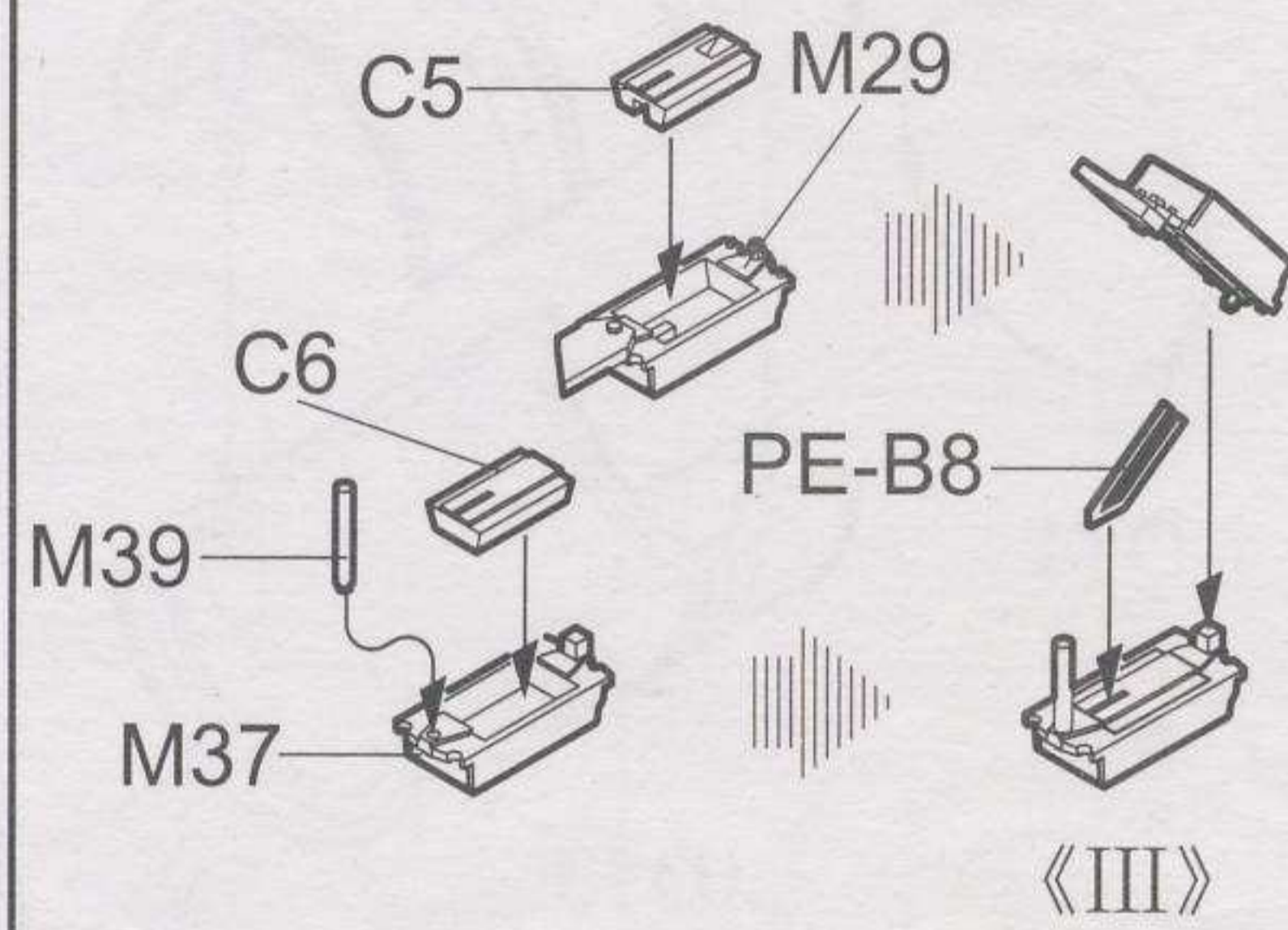
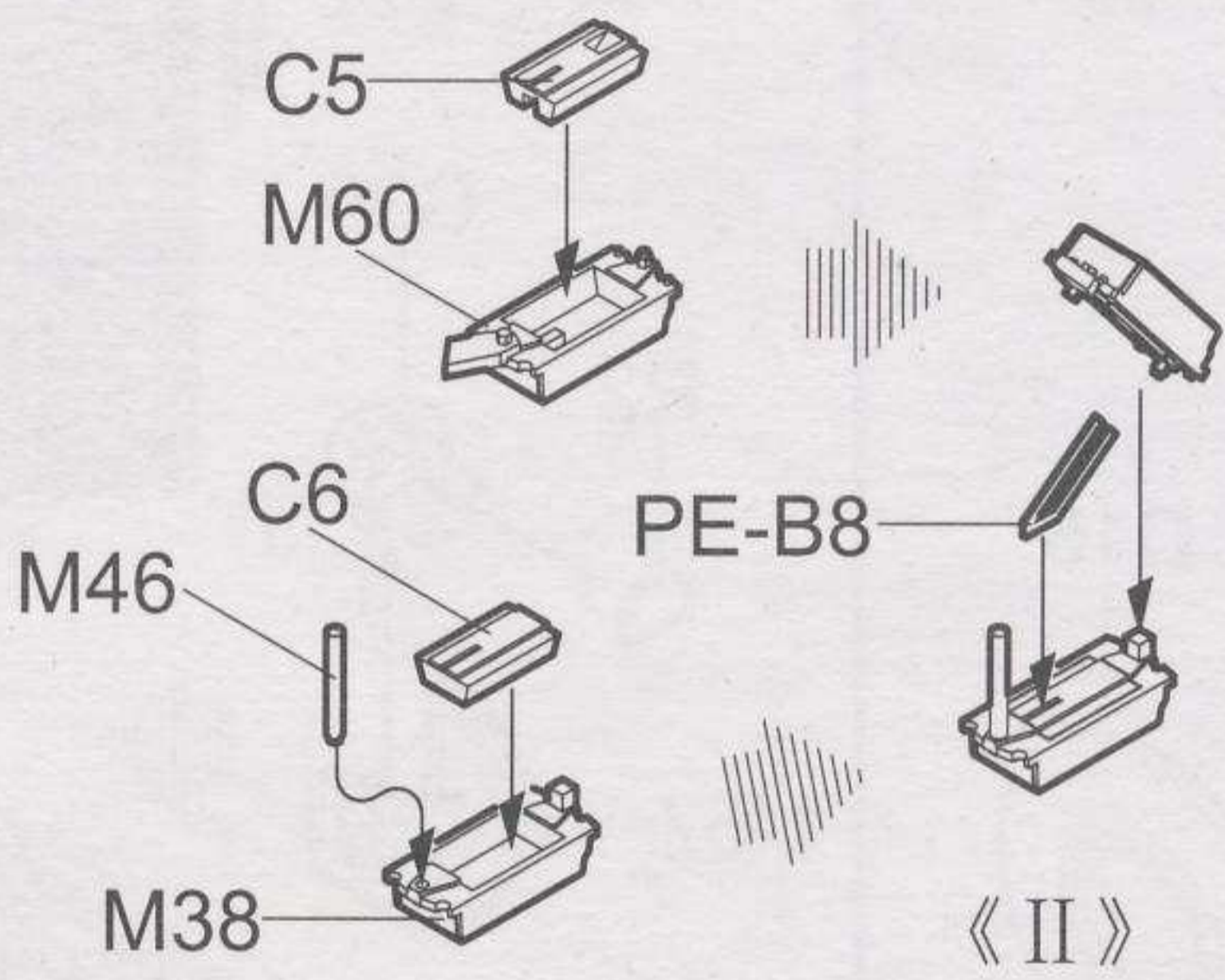
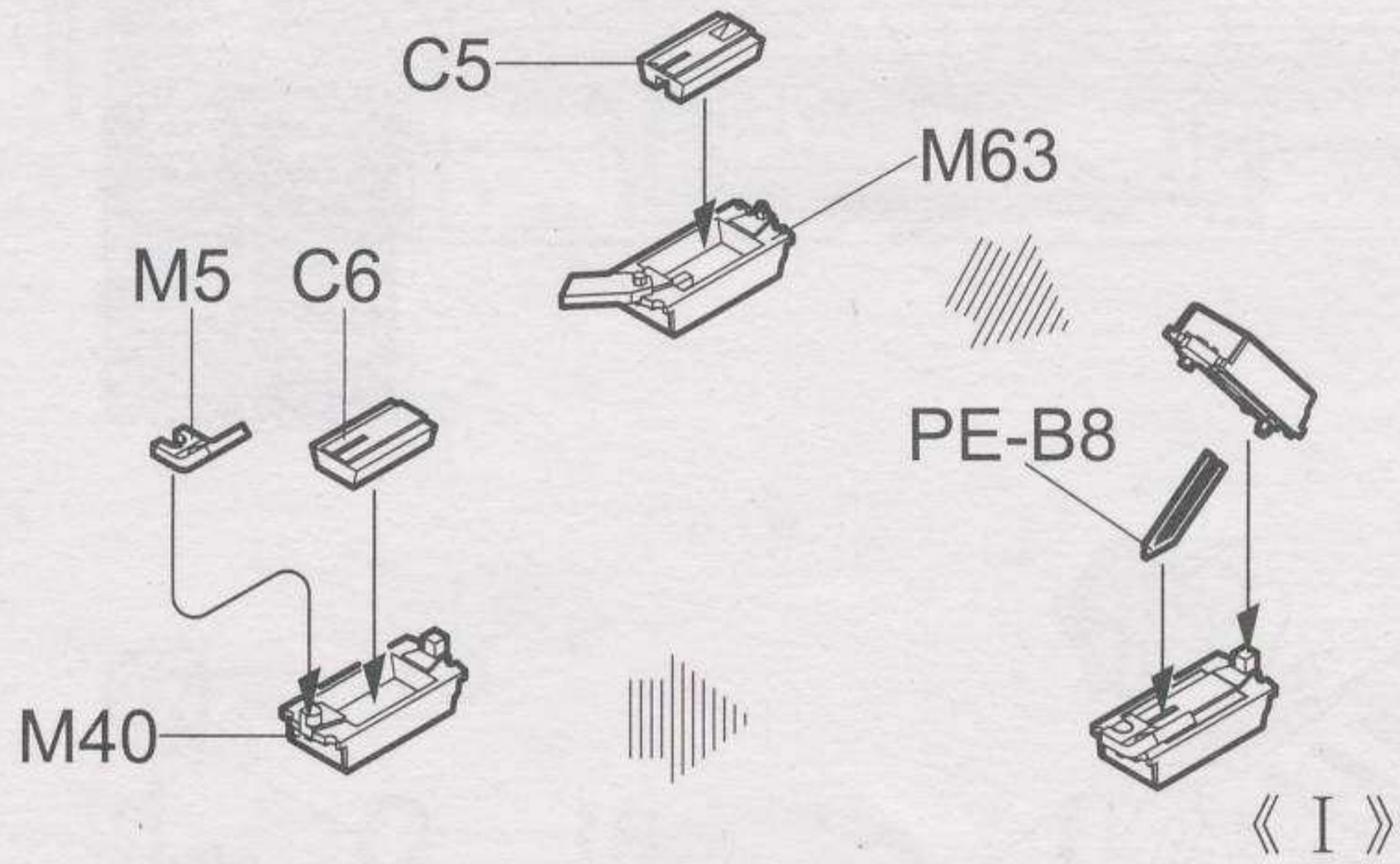
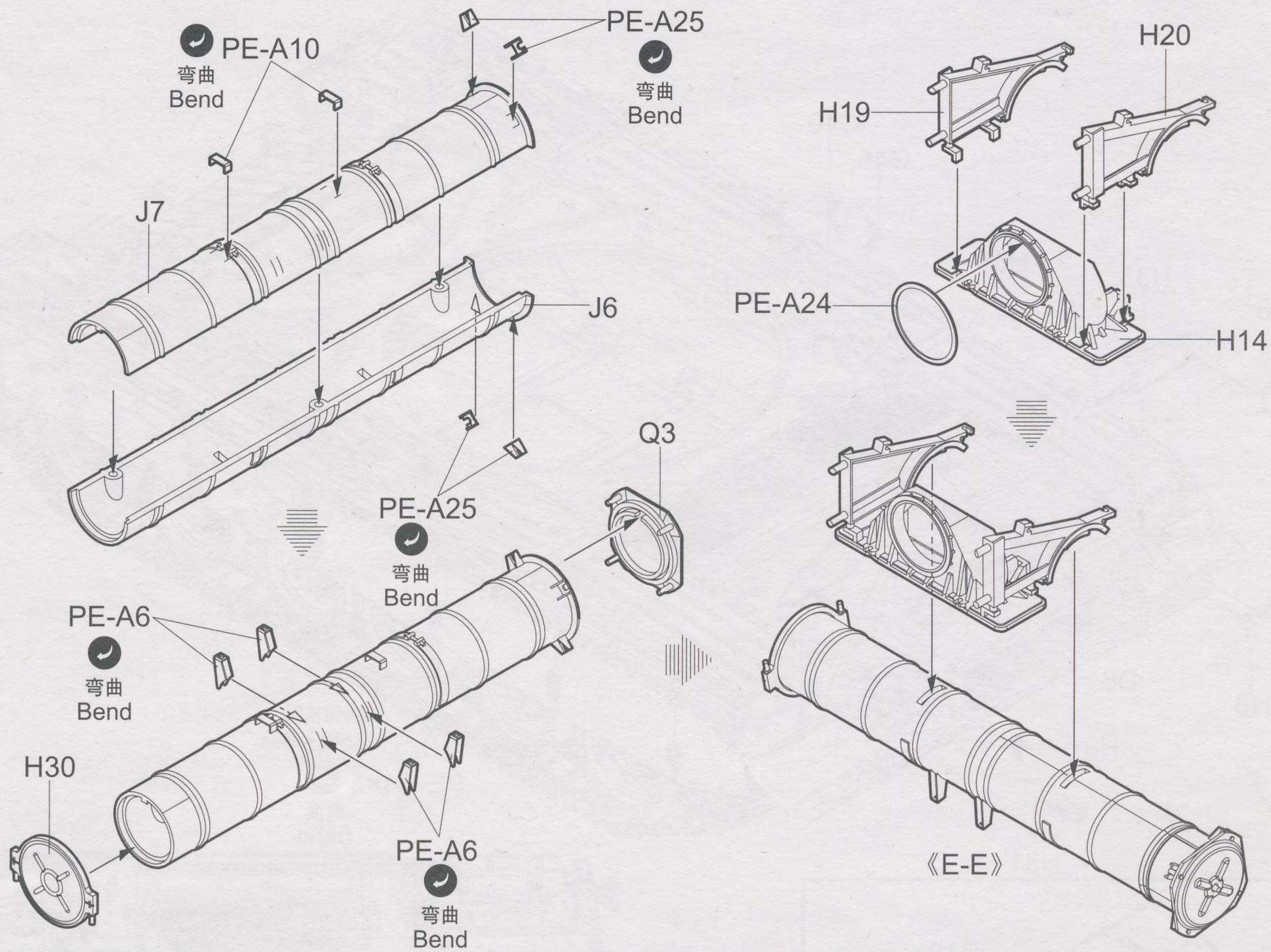

16

①
钻孔
Make hole

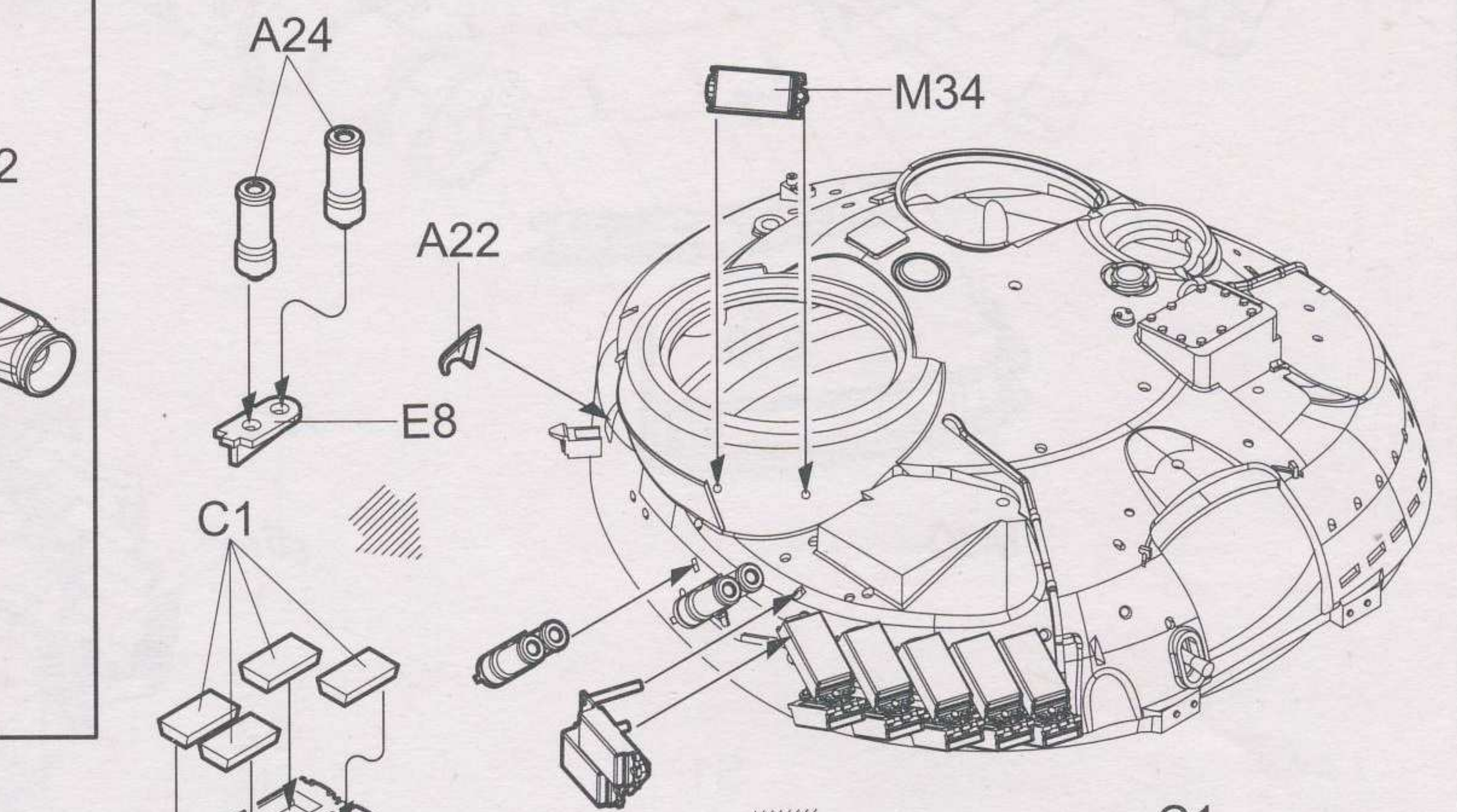
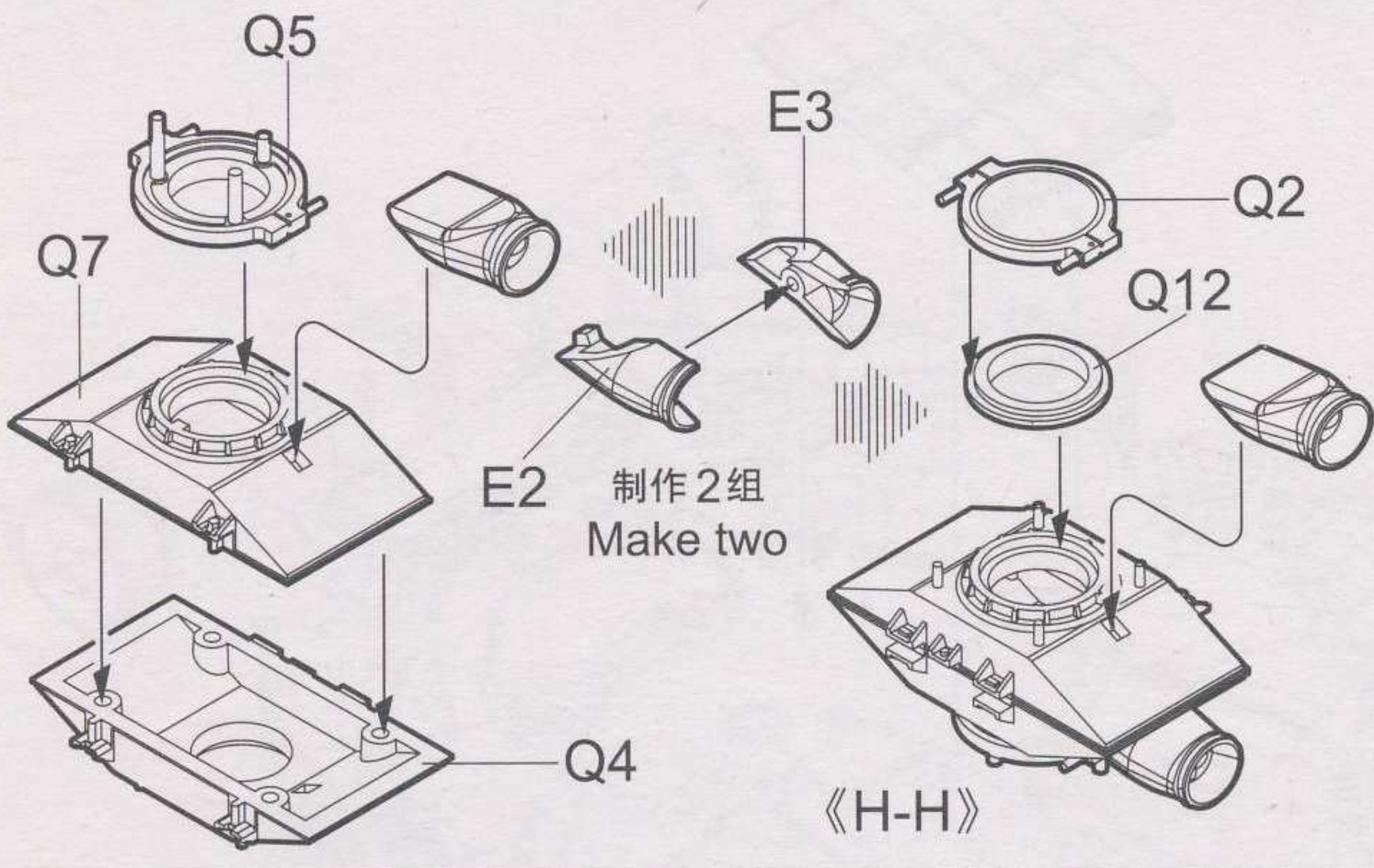
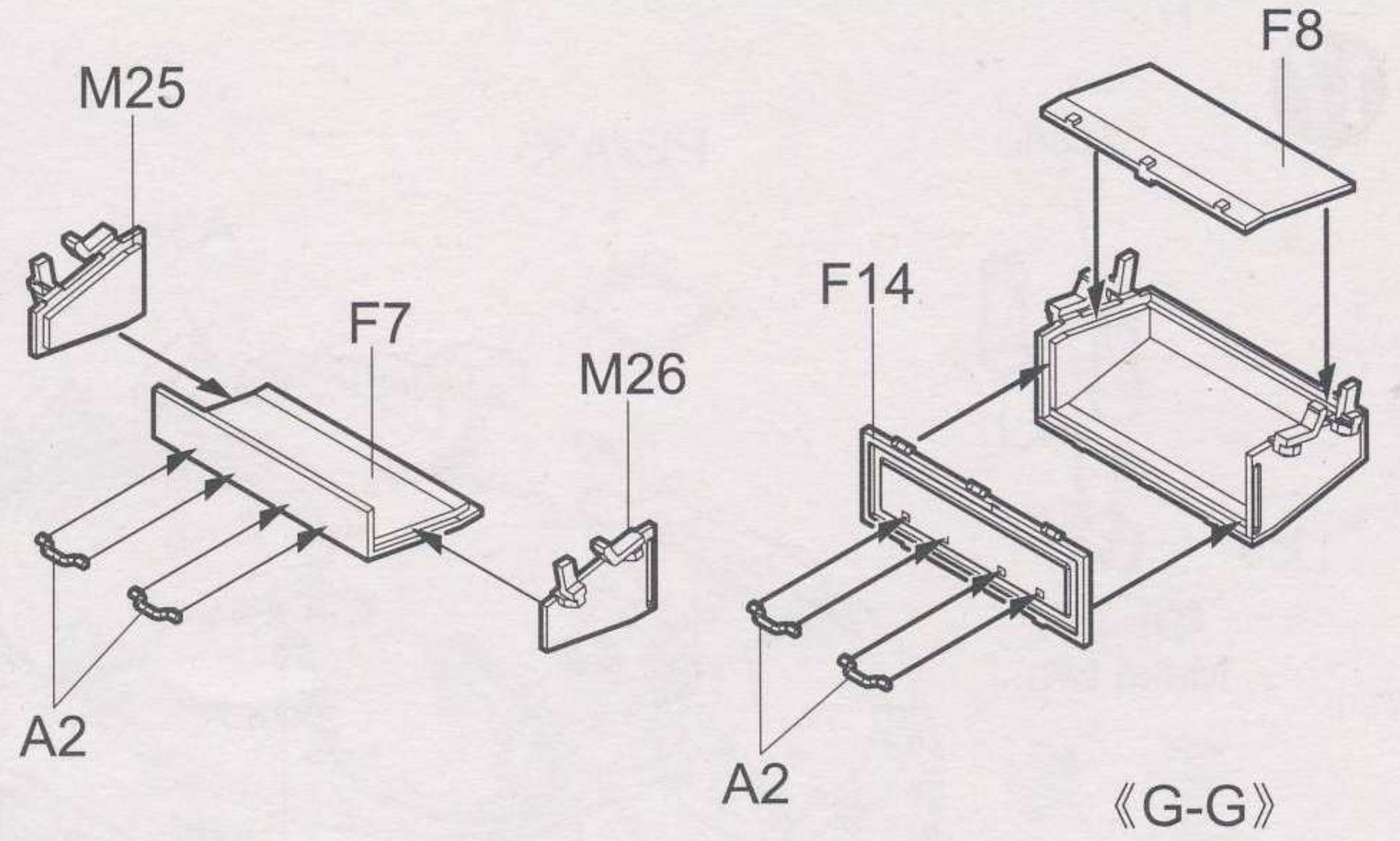
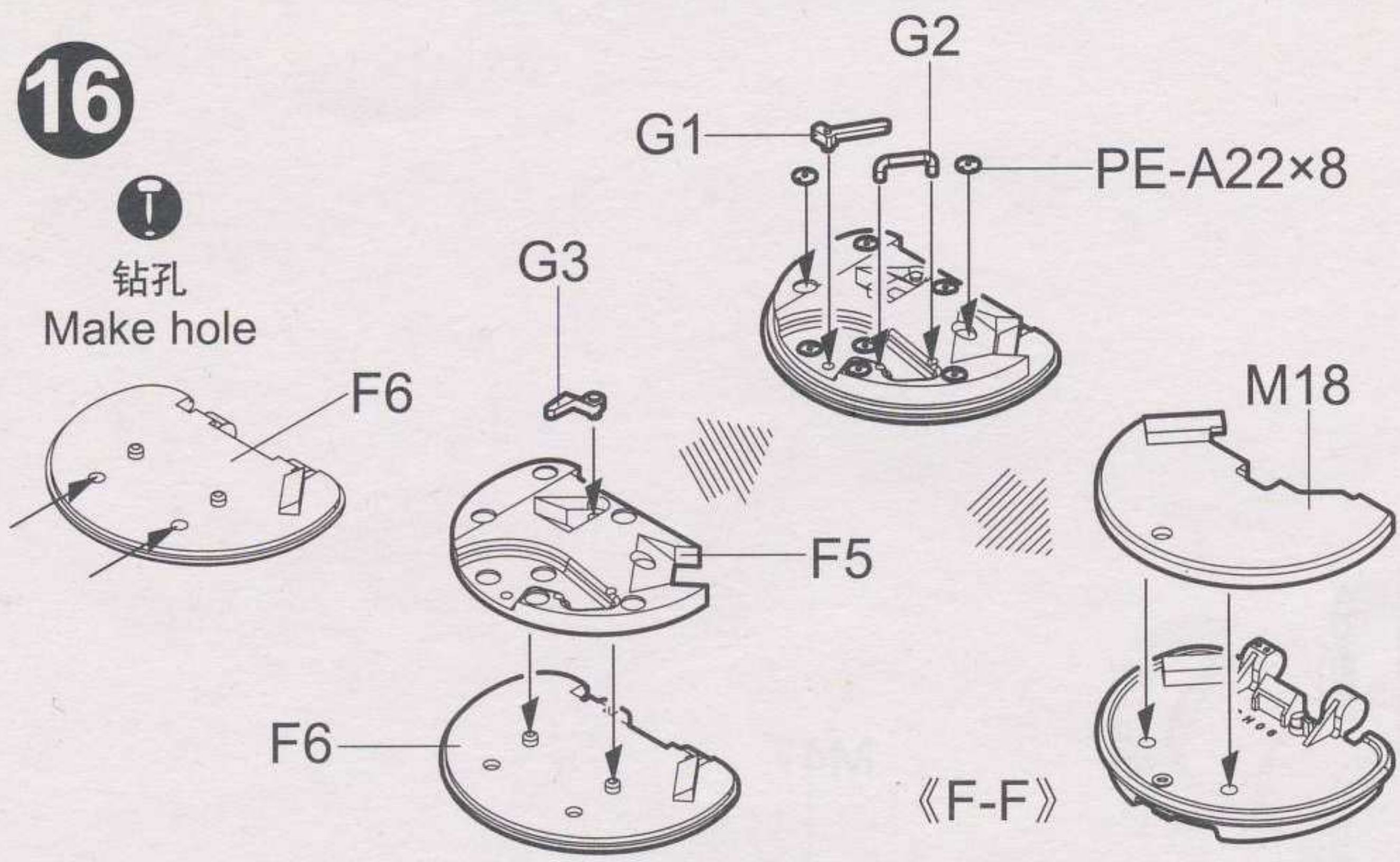

弯曲
Bend
PE-B2

弯曲
Bend

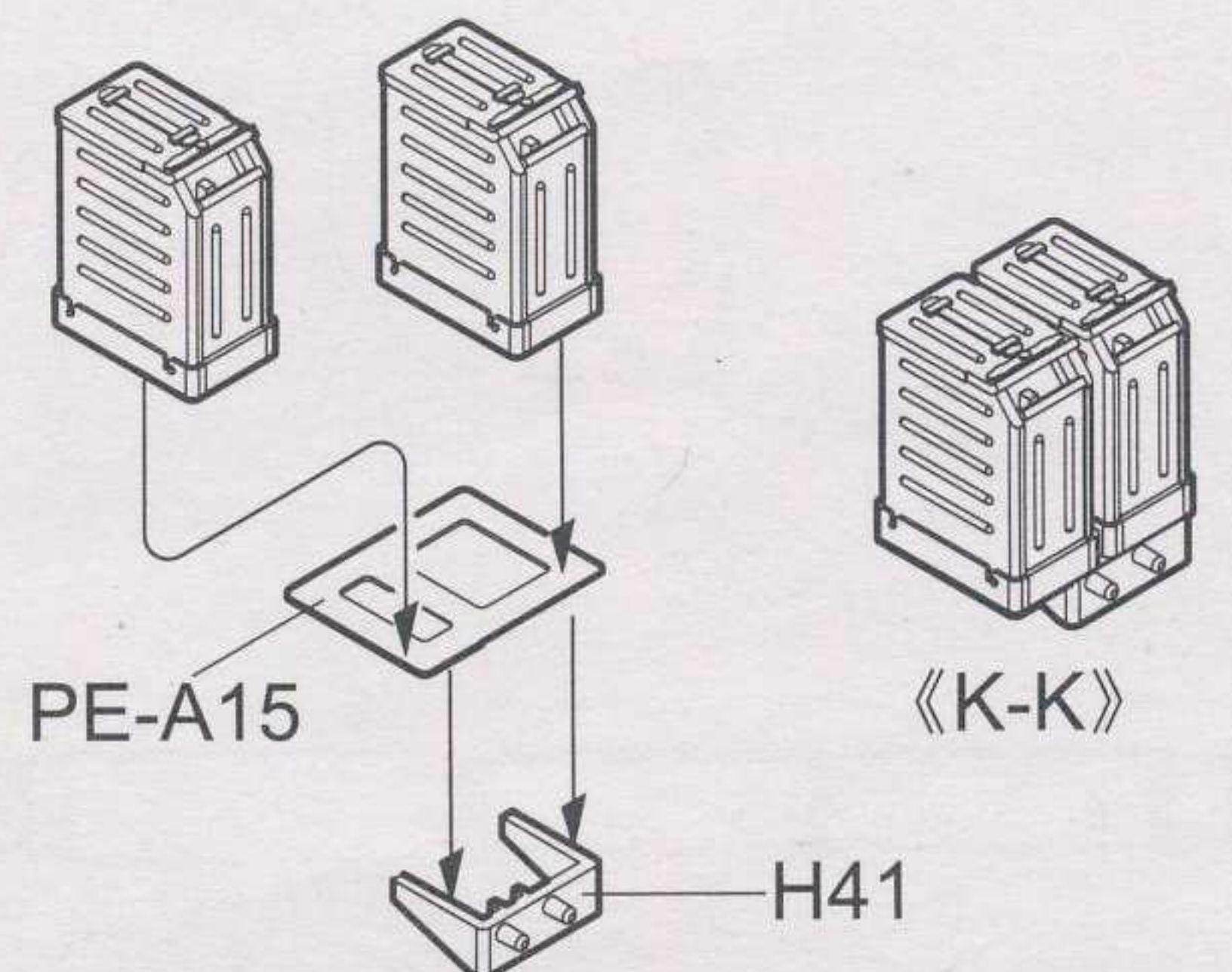
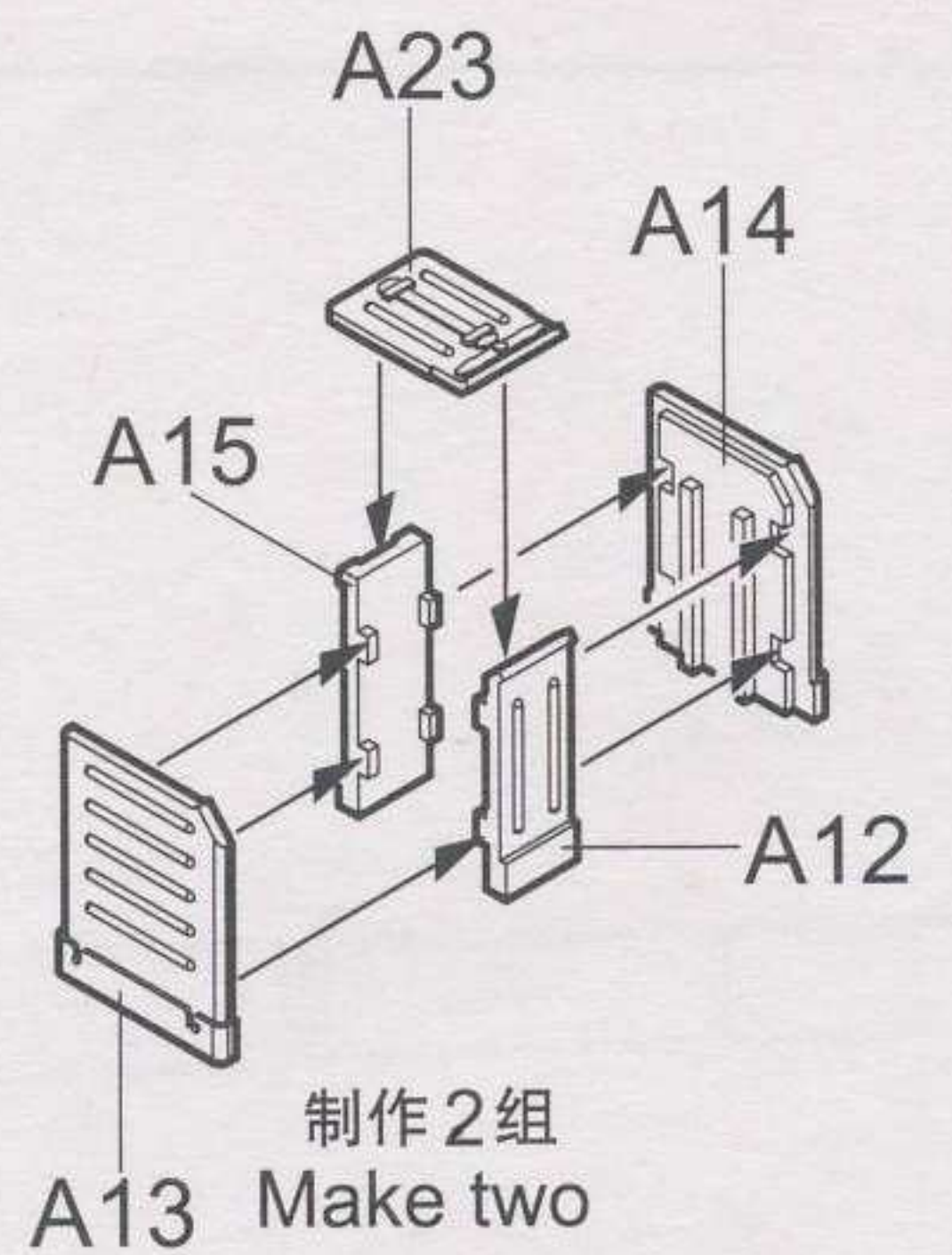
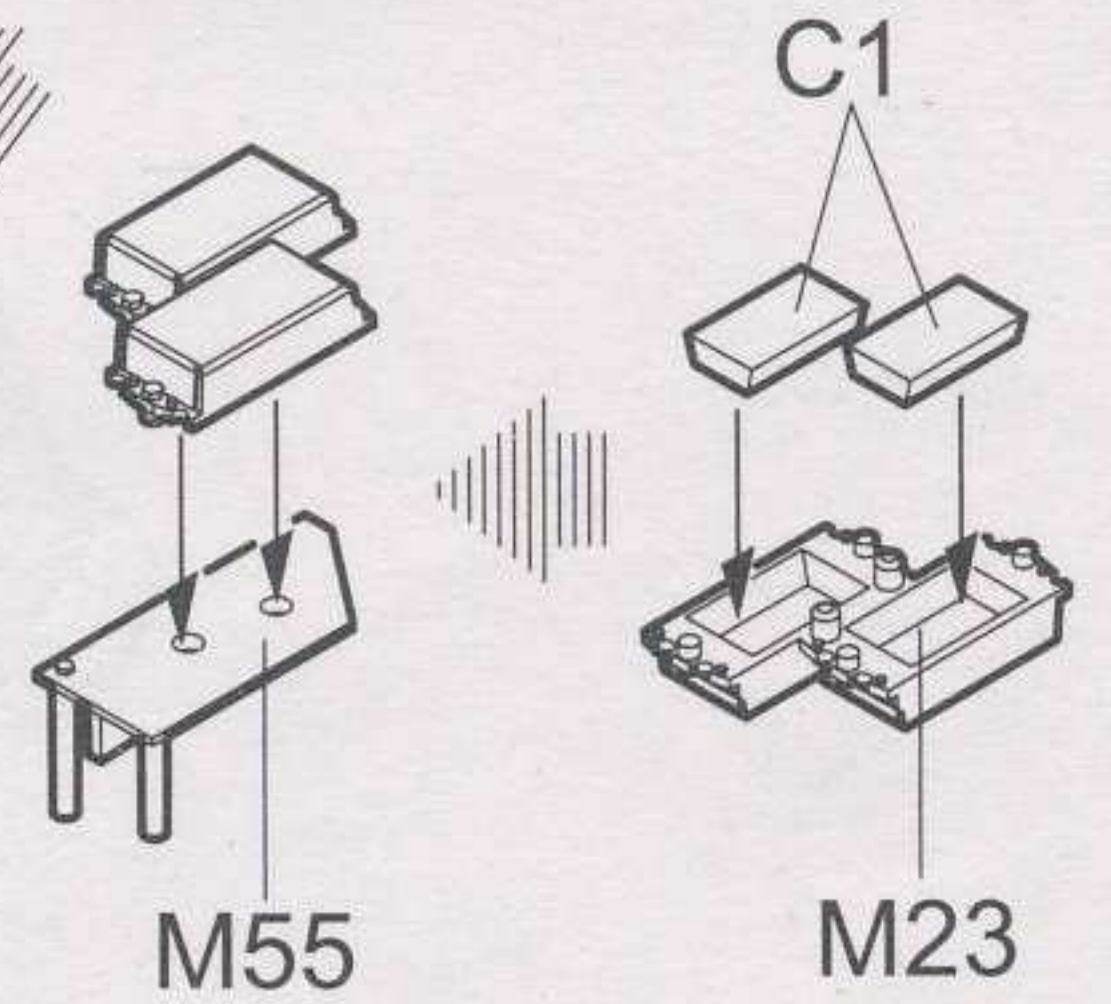
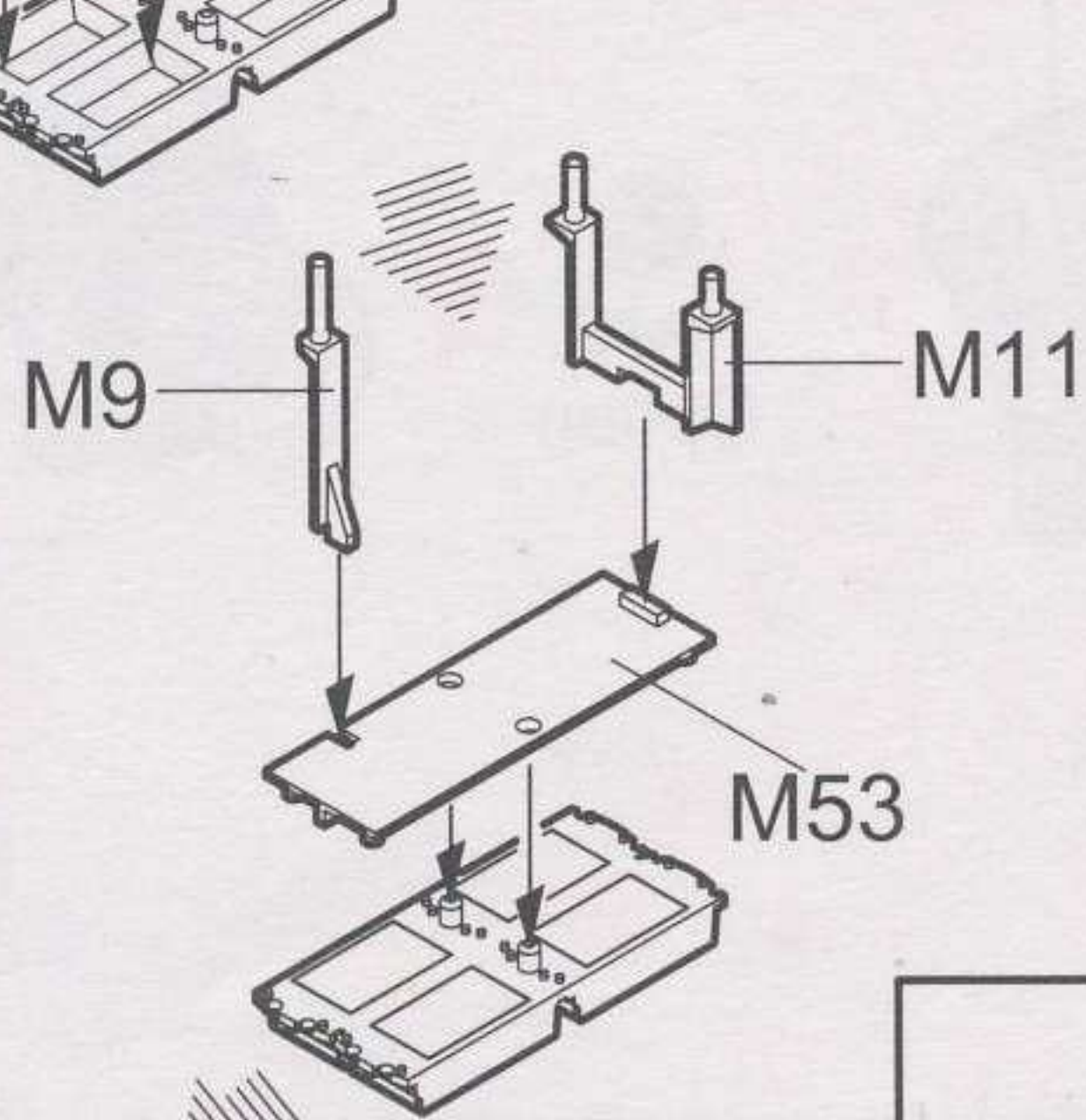
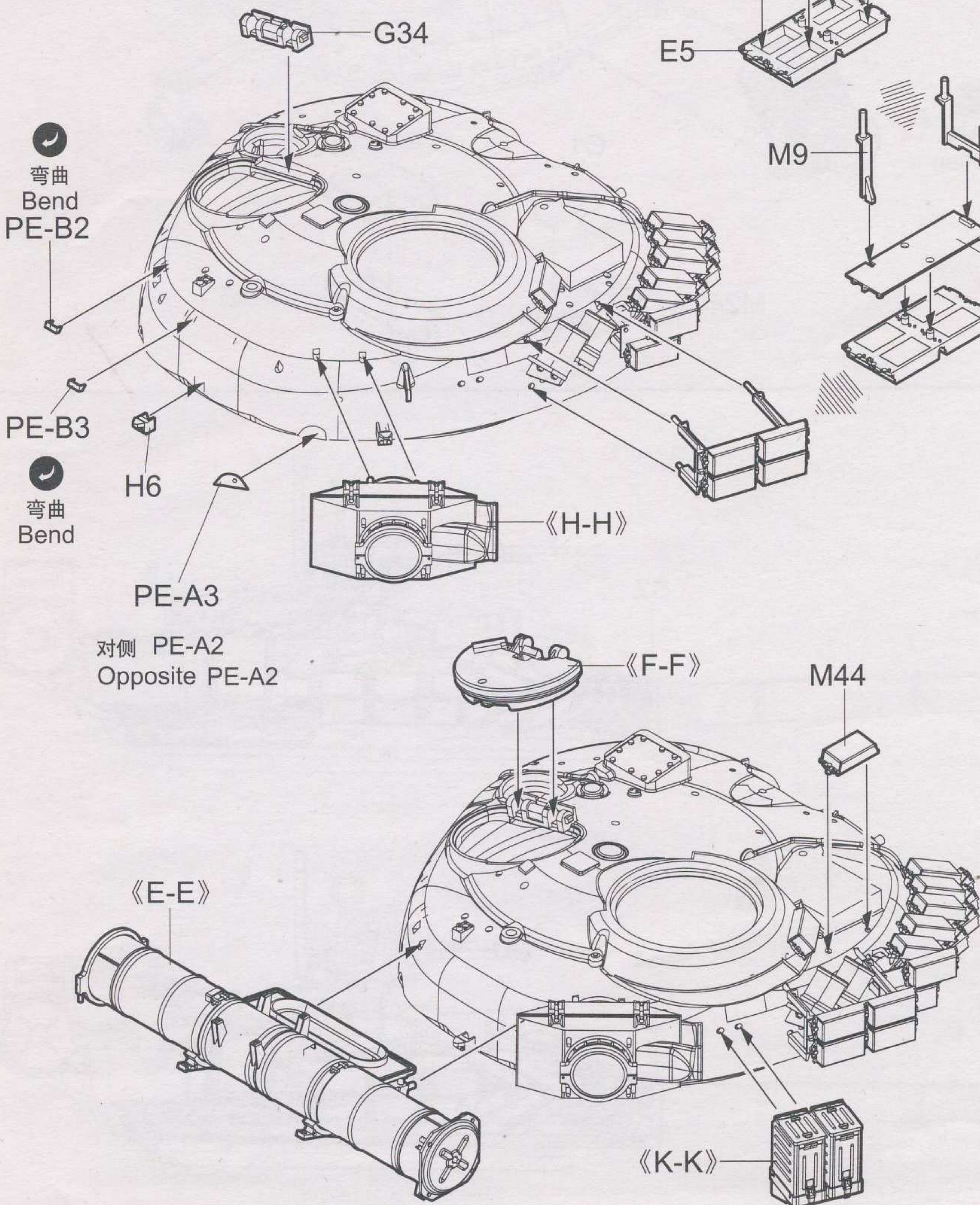

17

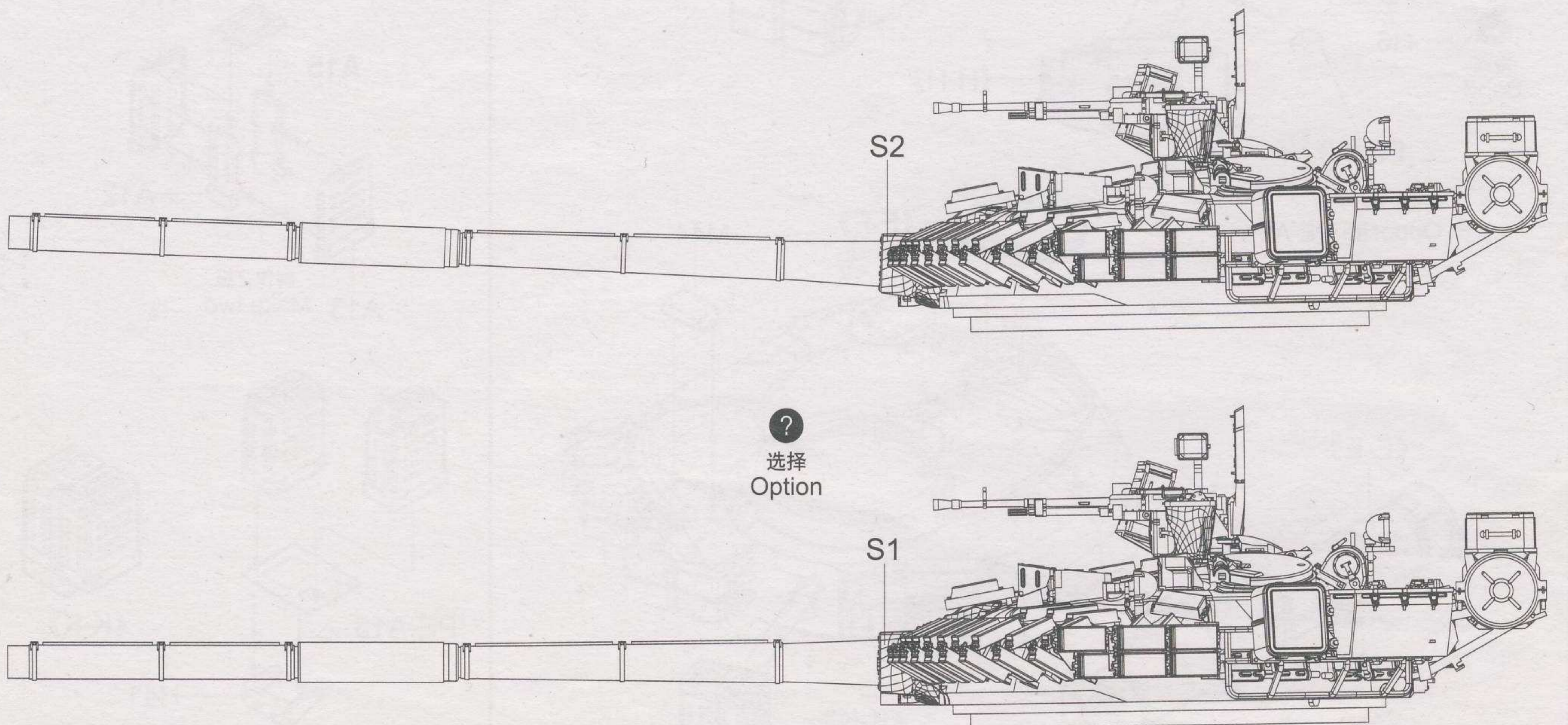
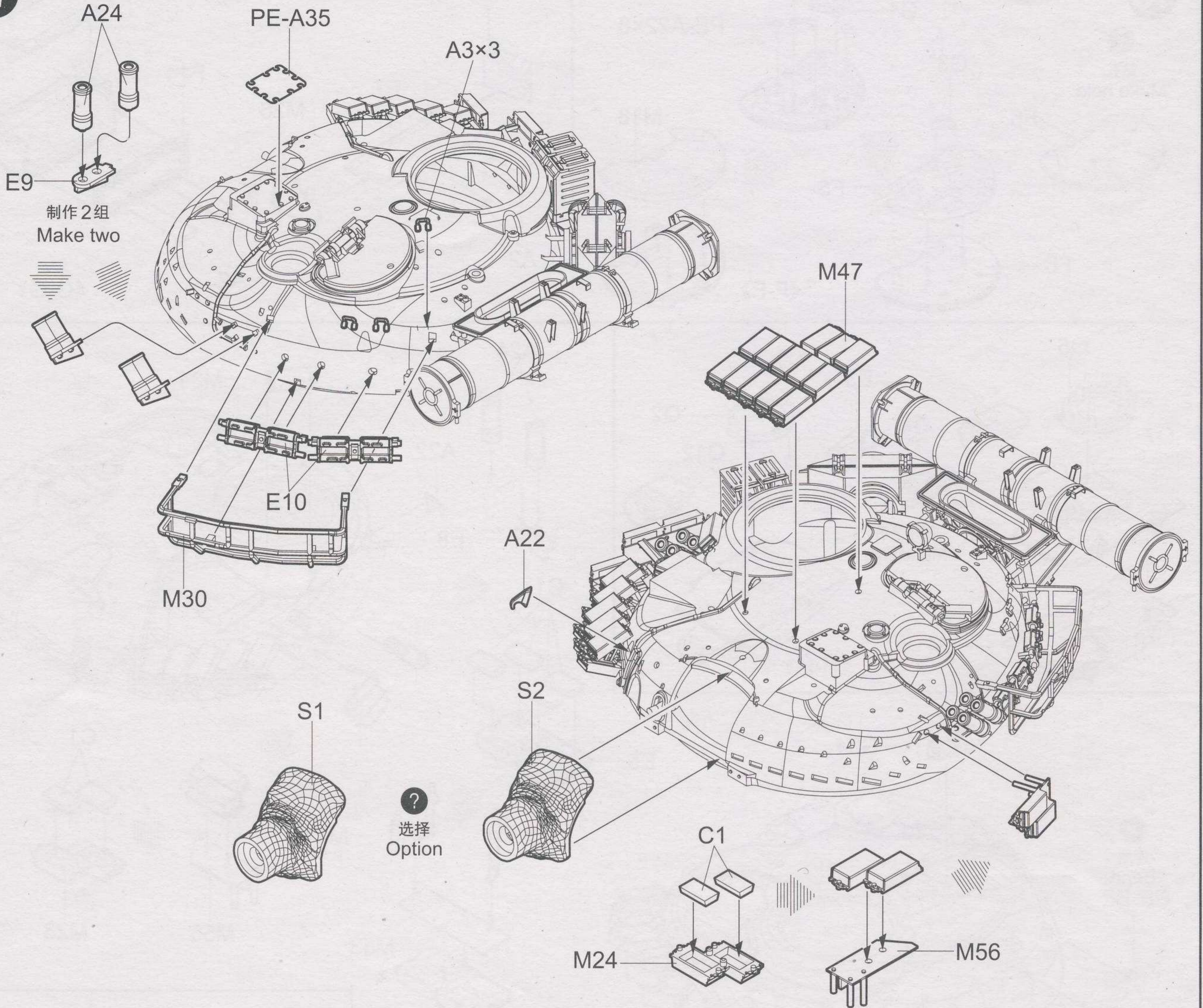

18

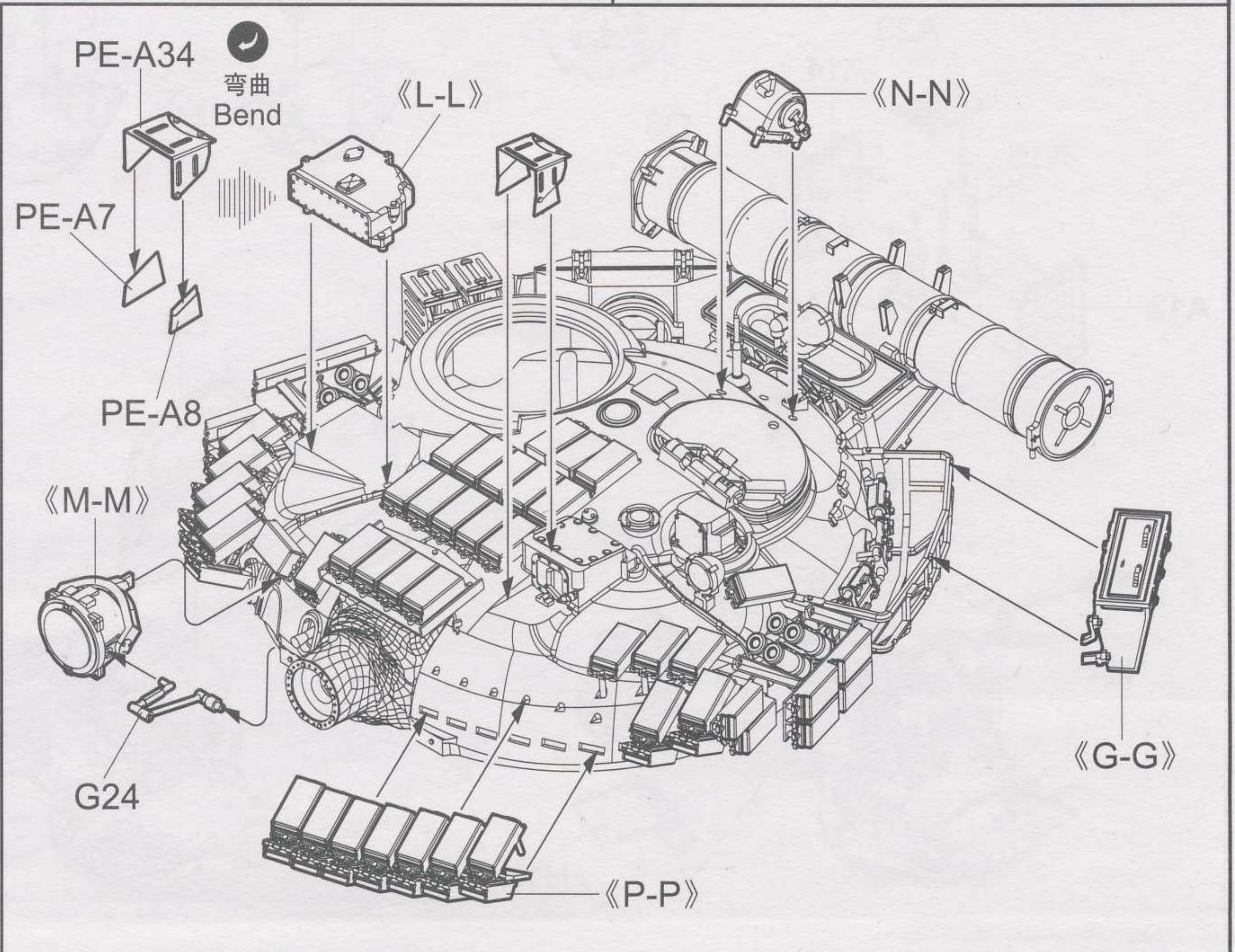
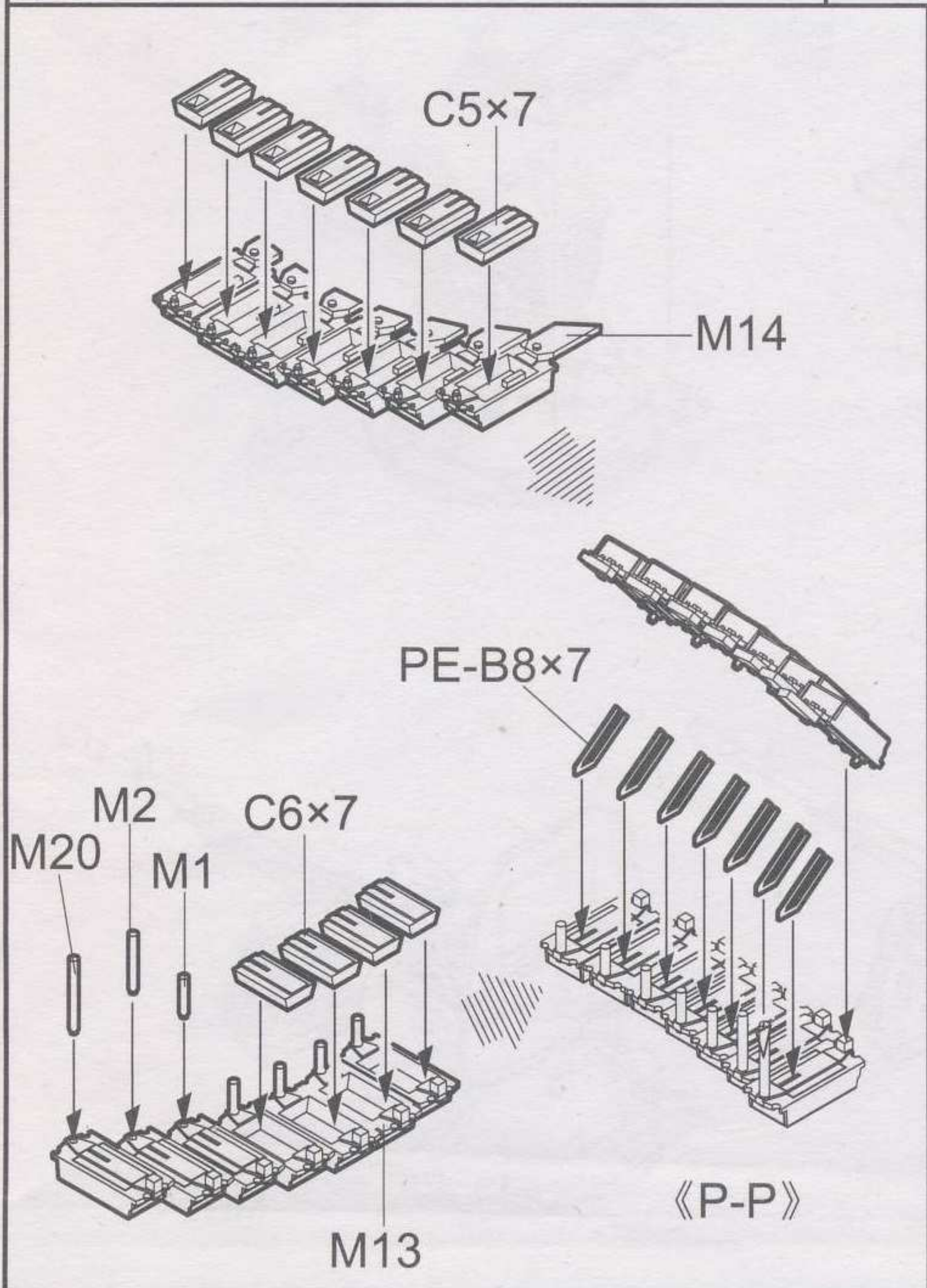
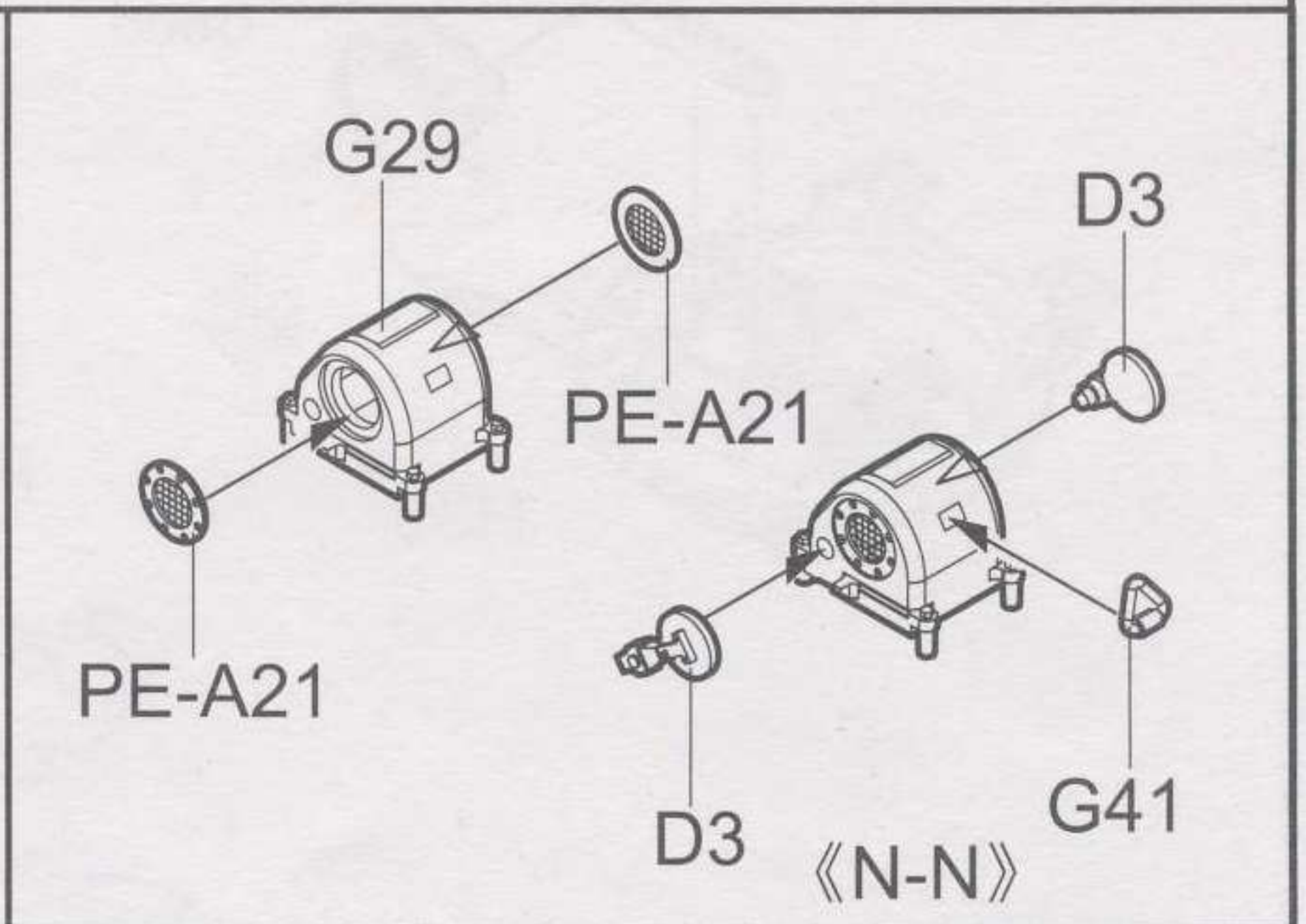
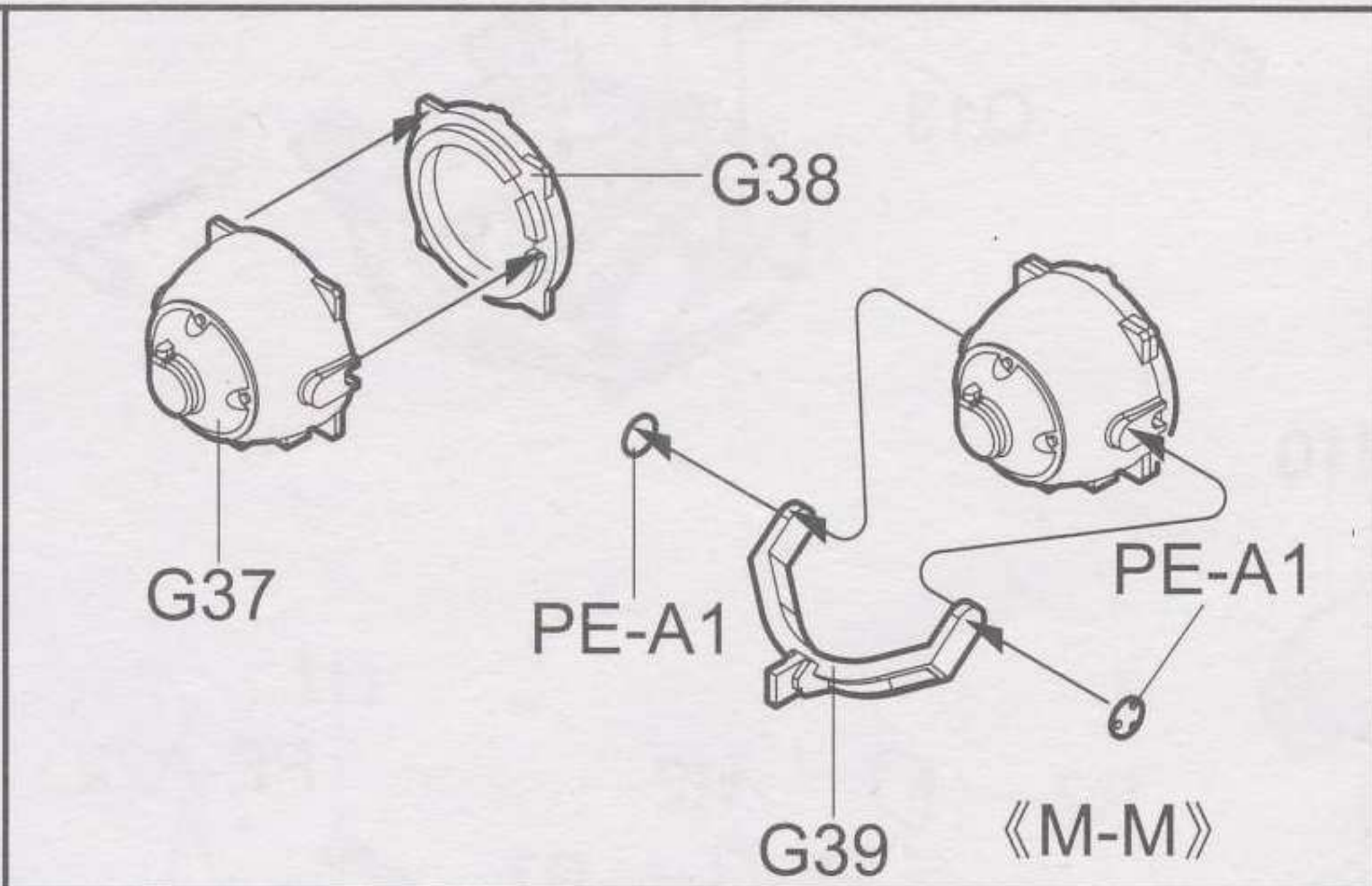
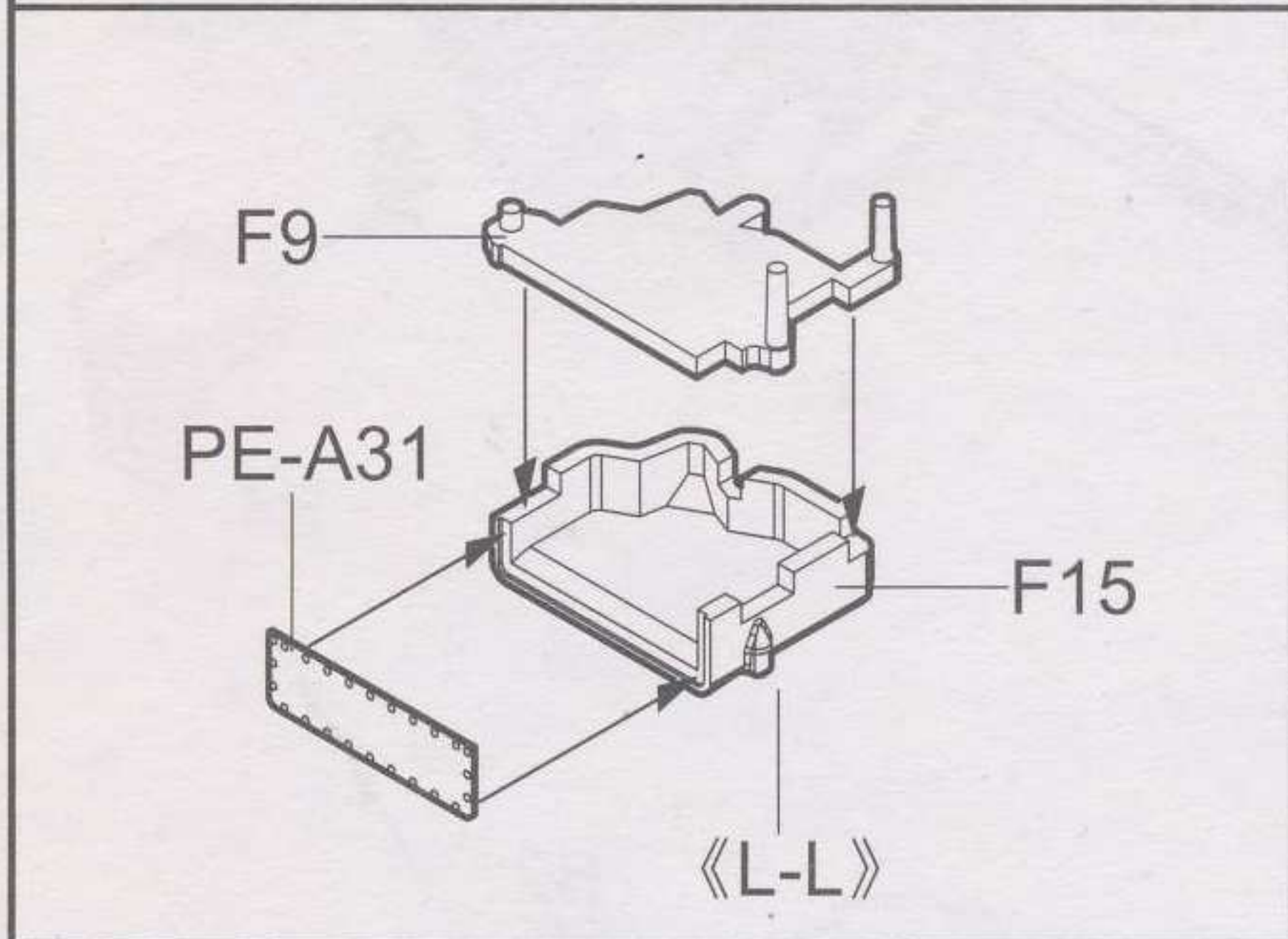
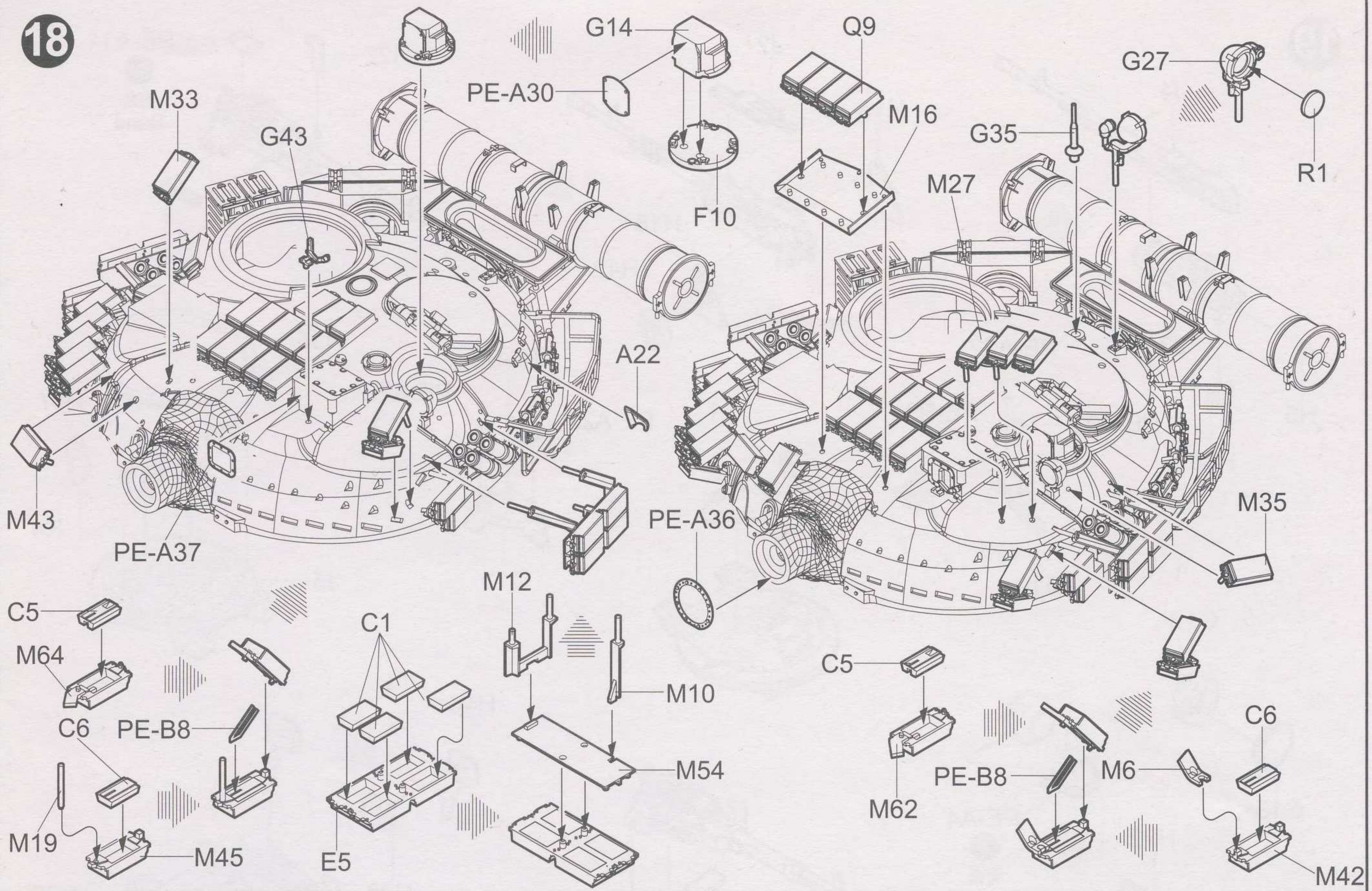

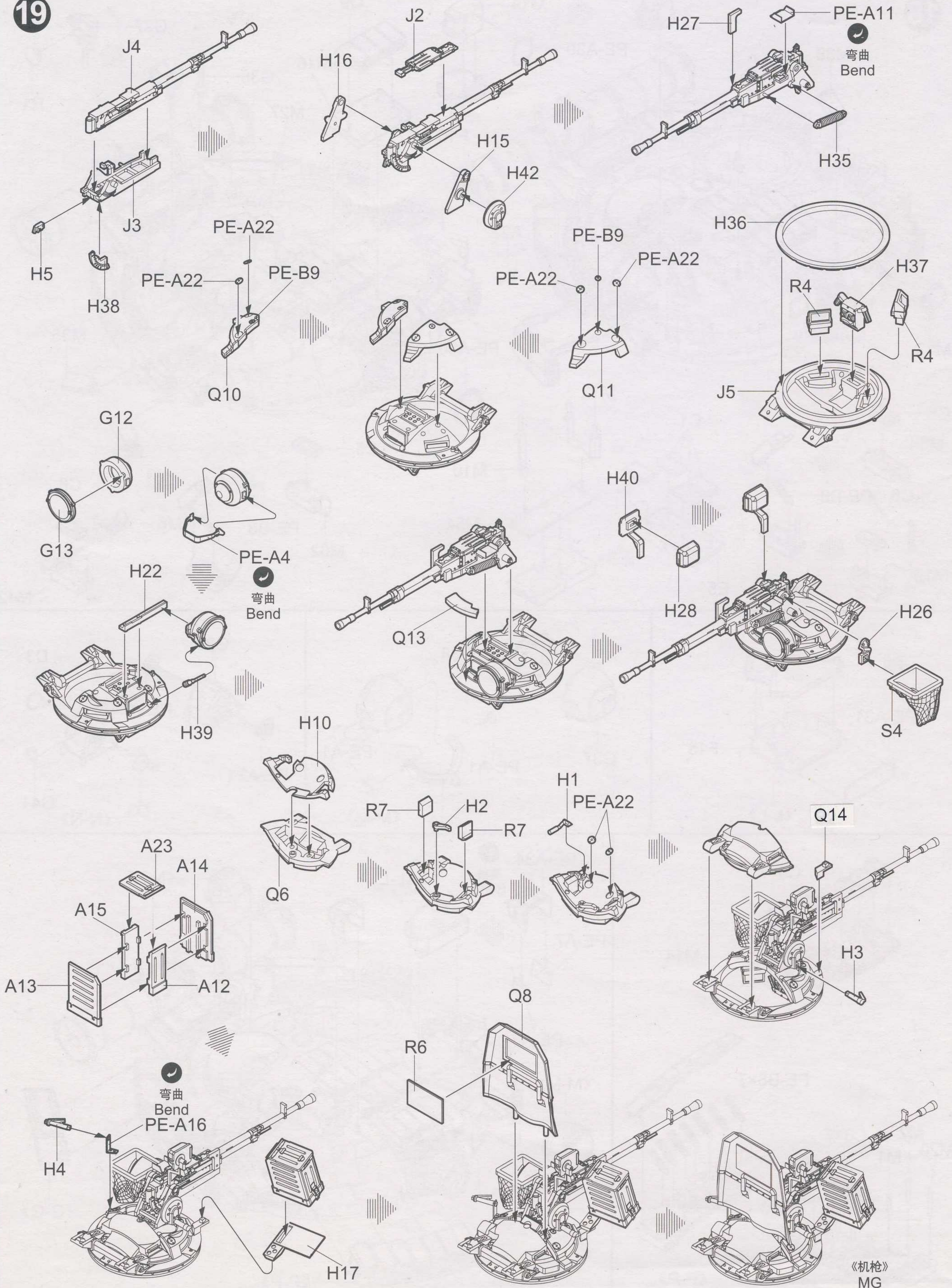

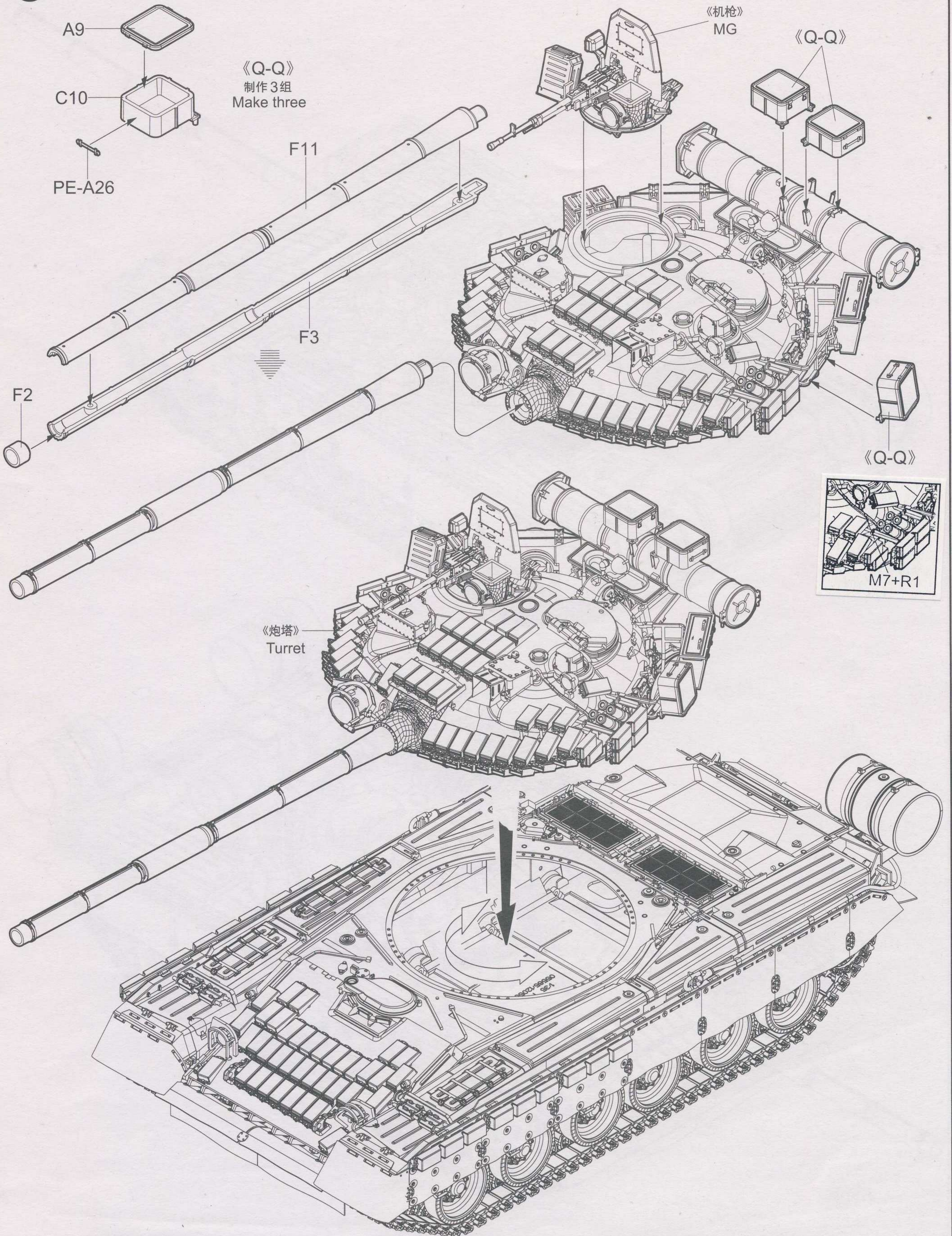

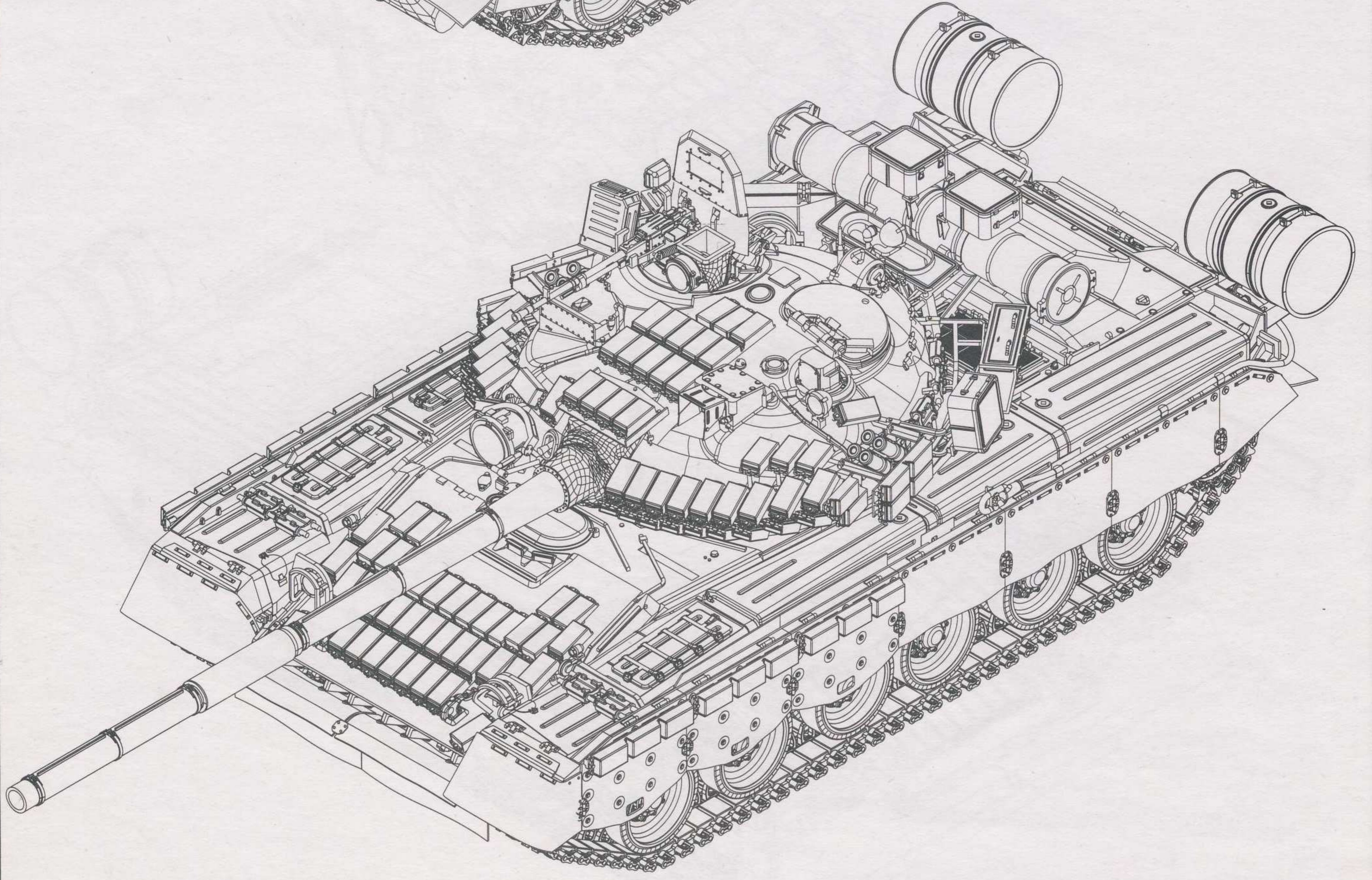
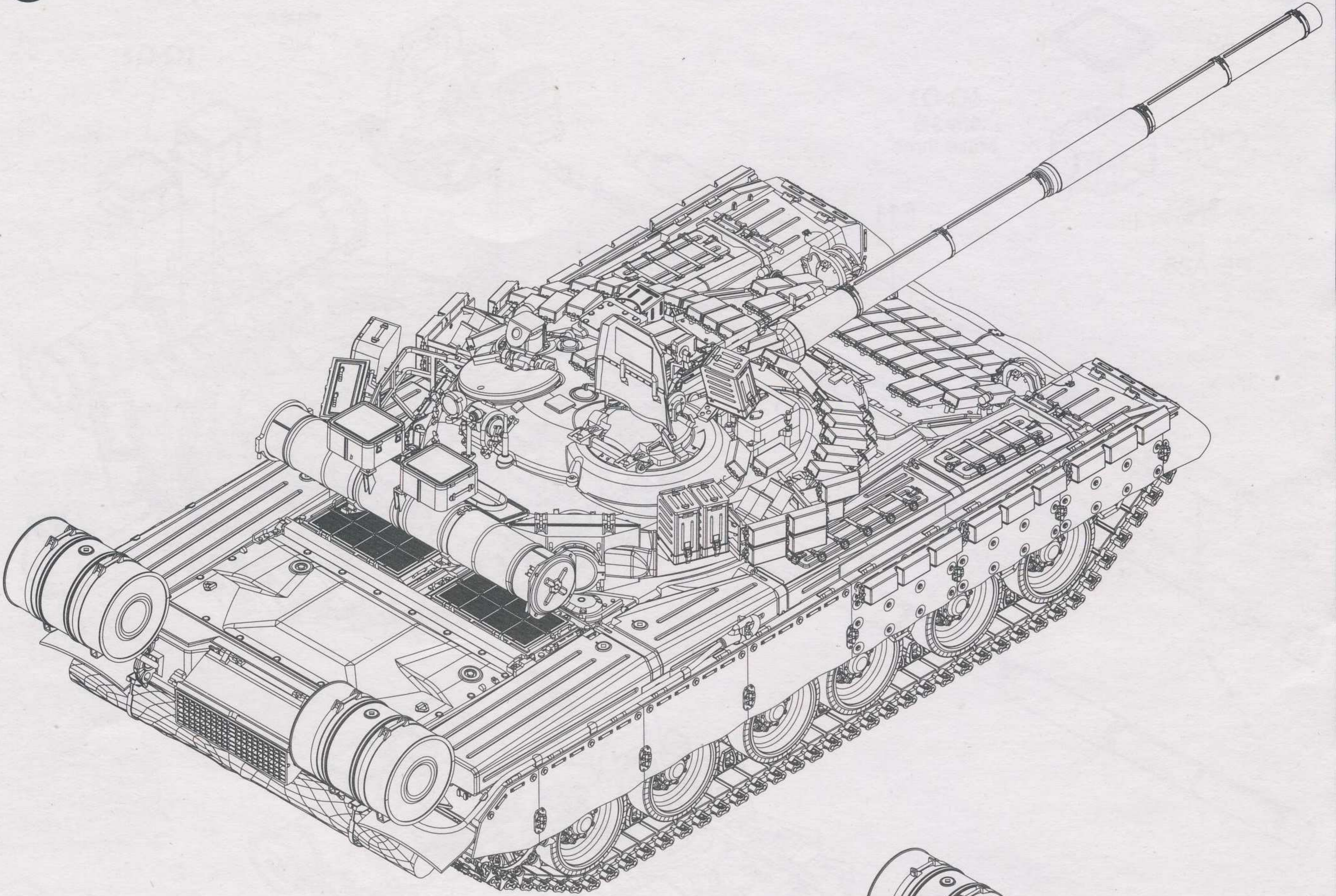

涂装同标贴指示

Painting & Marking guide

B

PAINT REFERENCE COLOUR

Color	Mr.Hobby	Vallejo	Model Master	Tamiya	Humbrol
Light Green 绿色	H 303 303	—	1713	XF20	117
Sandy Brown 砂黄色	H 79 39	842	—	XF59	93
Tire Black 胎黑色	H 77 137	—	—	—	—
Metal Black 黑铁色	H 18 28	864	1402	—	—
Flat Black 哑光黑	H 12 33	950	1749	XF1	33

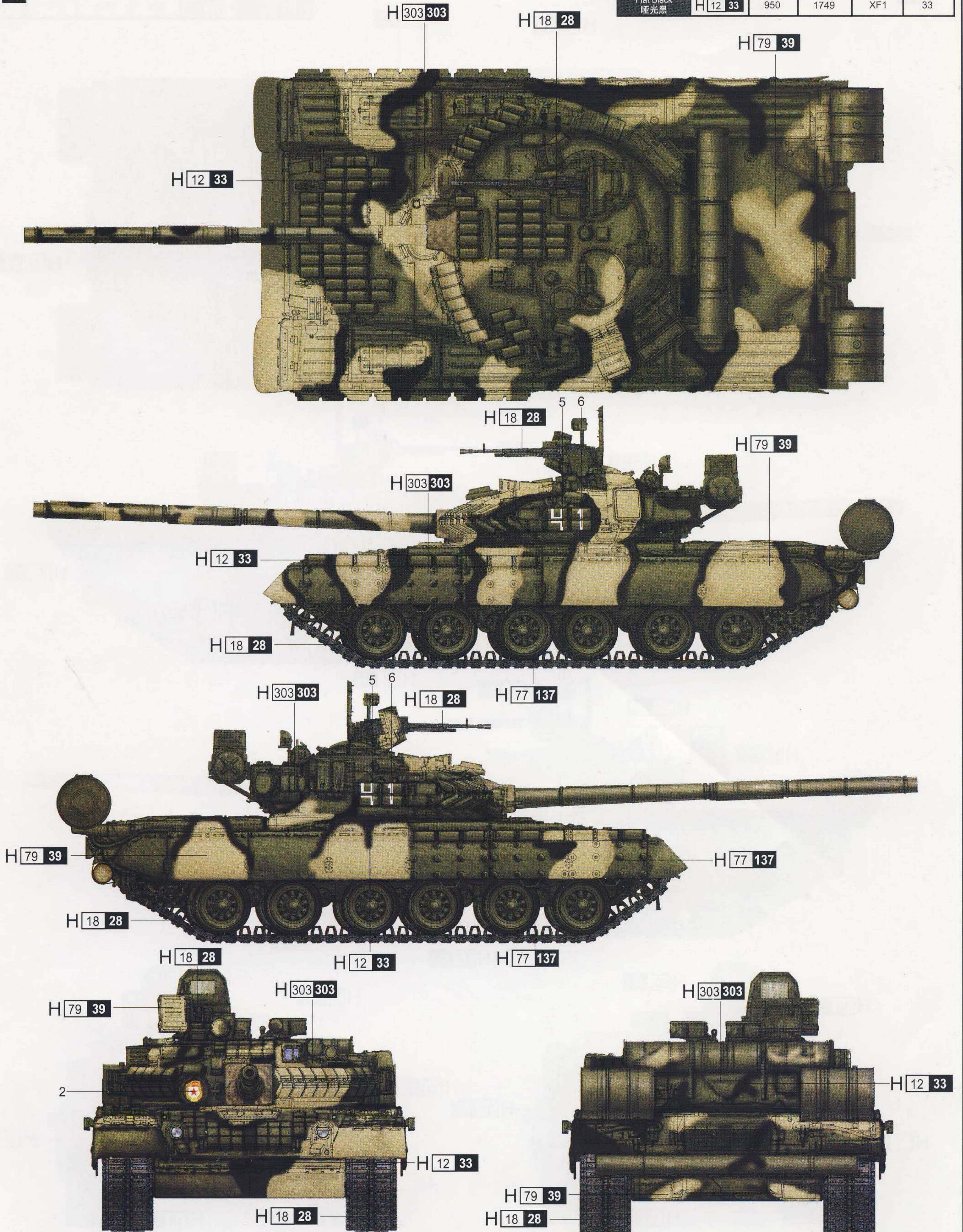

H □ AQUEOUS HOBBY COLOR ■ Mr. COLOR

涂装同标贴指示 Painting & Marking guide

PAINT REFERENCE COLOUR

Color	Mr.Hobby	Vallejo	Model Master	Tamiya	Humbrol
Light Green 绿色	H 303 303	—	1713	XF20	117
Light Blue 浅蓝色	H 20	965	—	XF8	—
Tire Black 胎黑色	H 77 137	—	—	—	—
Metal Black 黑铁色	H 18 28	864	1402	—	—
Wood Brown 木棕色	H 37 43	983	1701	—	186

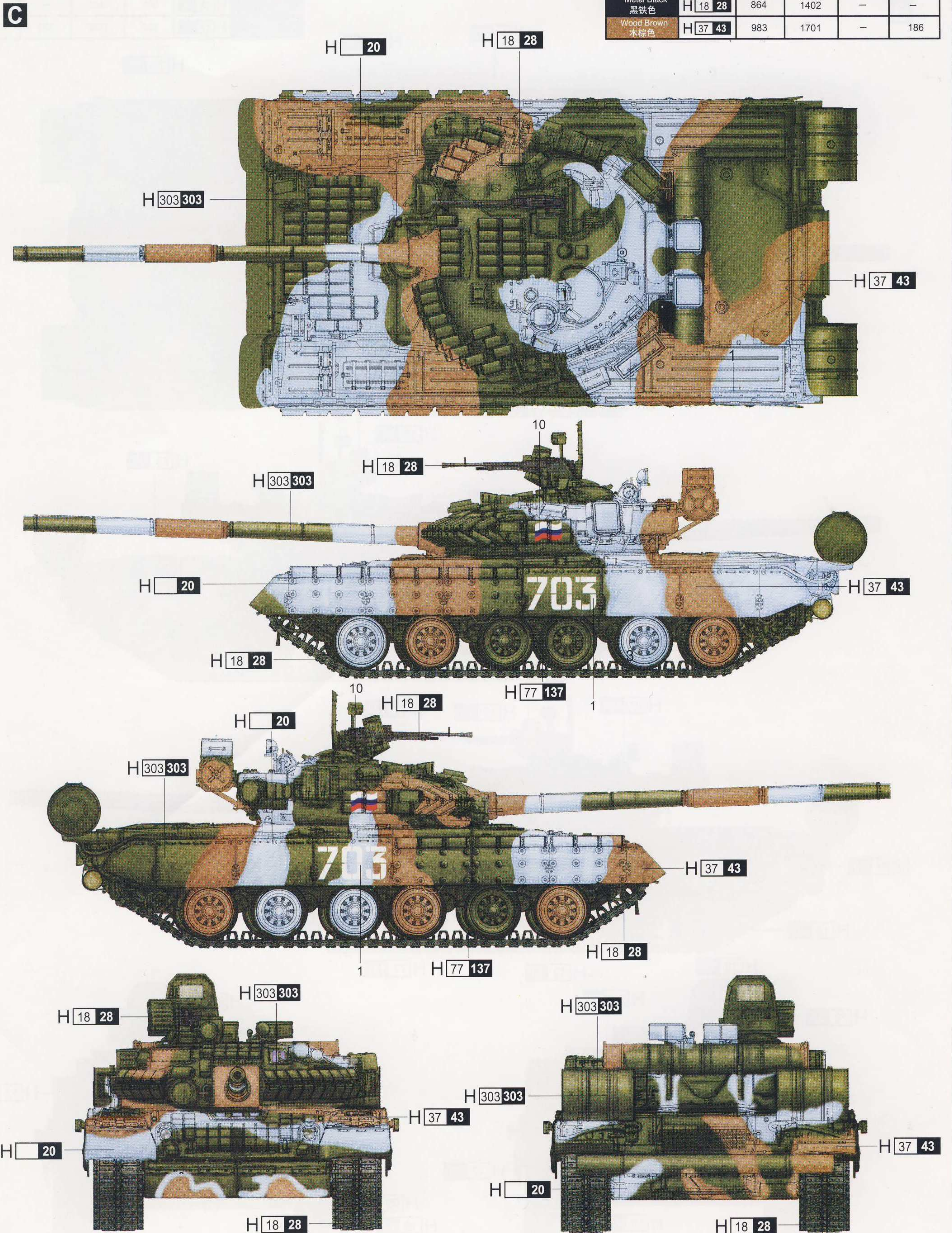

H AQUEOUS HOBBY COLOR ■ Mr. COLOR

涂装同标贴指示

Painting & Marking guide

D

PAINT REFERENCE COLOUR

Color	Mr.Hobby	Vallejo	Model Master	Tamiya	Humbrol
Light Green 绿色	H 303 303	—	1713	XF20	117
Aircraft Gray 灰白色	H 57 73	—	—	—	—
Tire Black 胎黑色	H 77 137	—	—	—	—
Metal Black 黑铁色	H 18 28	864	1402	—	—
Flat Black 哑光黑	H 12 33	950	1749	XF1	33

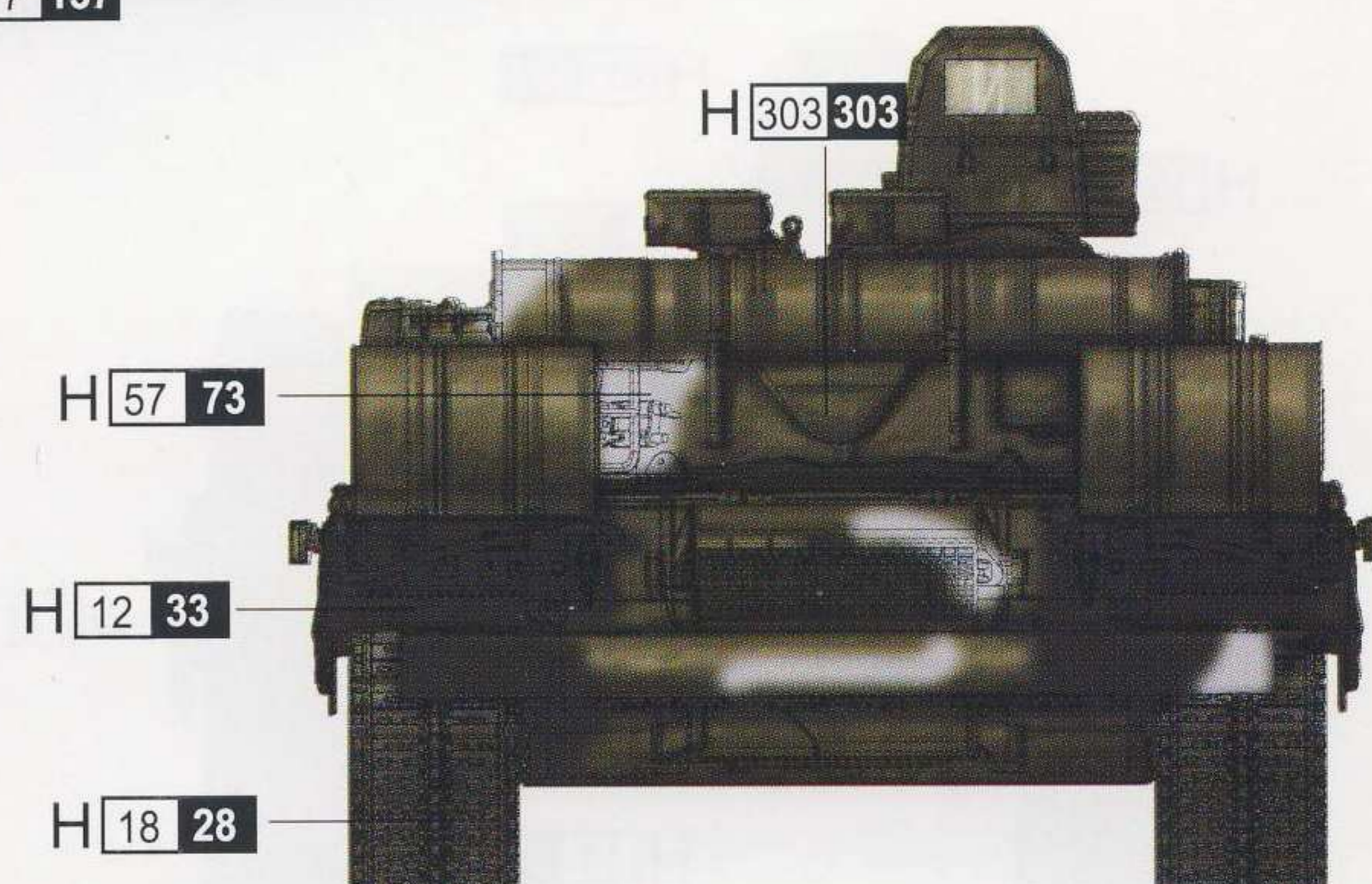
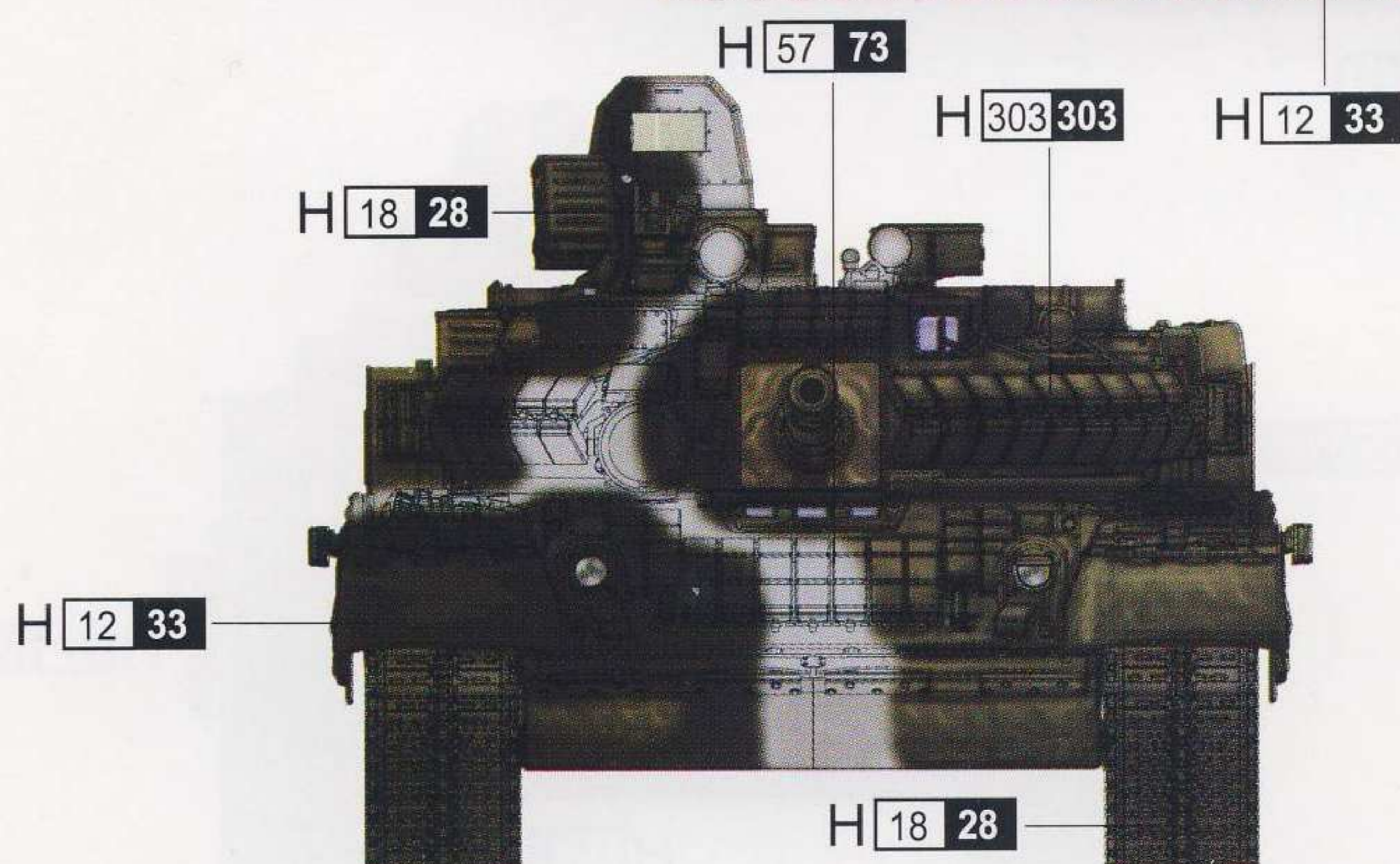
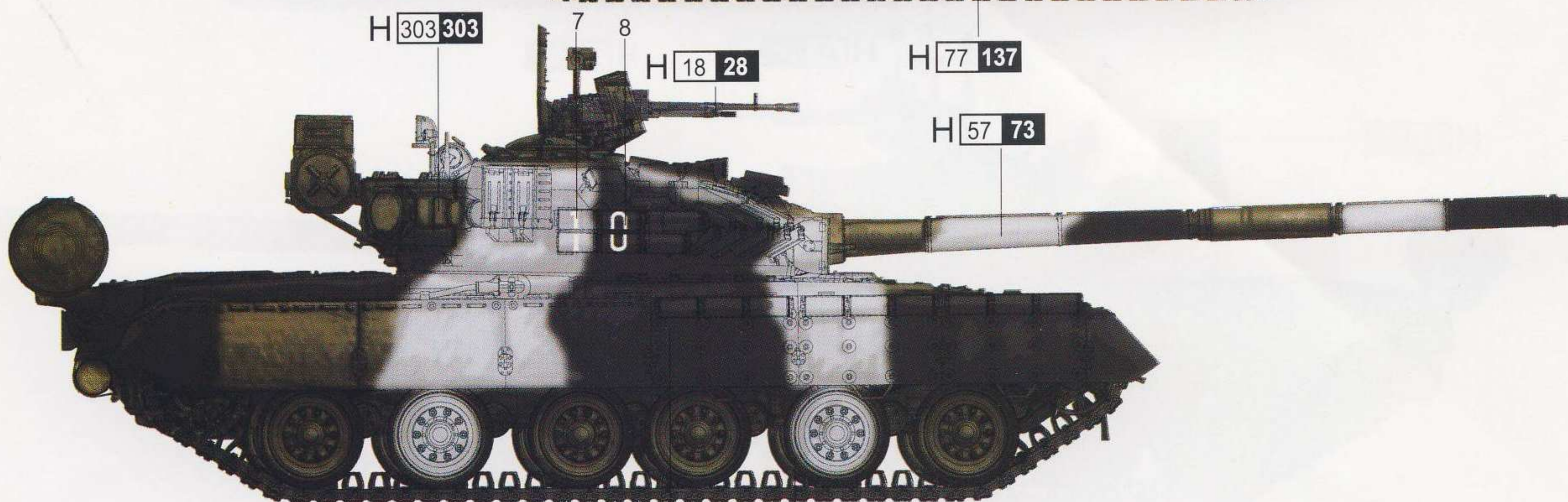
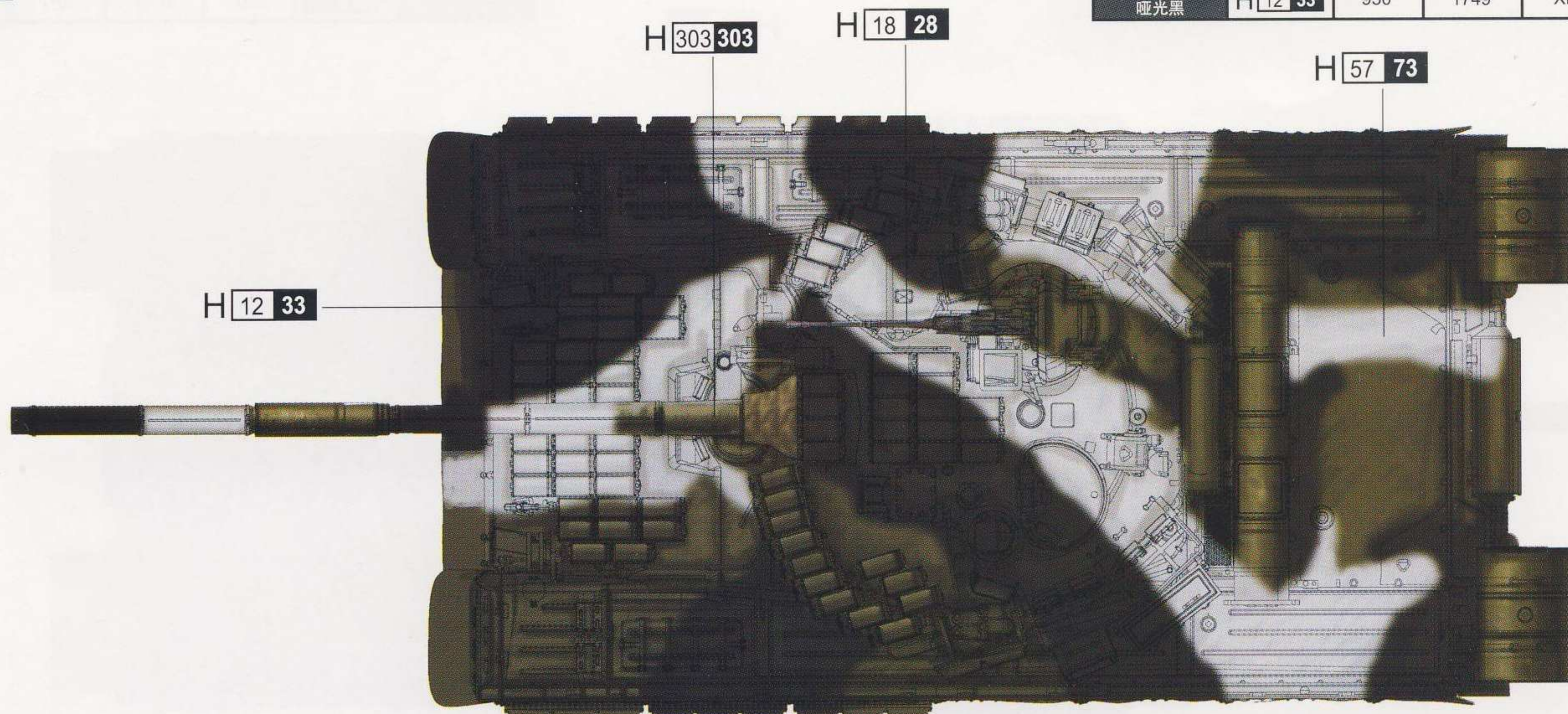

H □ AQUEOUS HOBBY COLOR ■ Mr. COLOR

涂装同标贴指示 Painting & Marking guide

PAINT REFERENCE COLOUR

Color	Mr.Hobby	Vallejo	Model Master	Tamiya	Humbrol
Light Green 绿色	H 303 303	—	1713	XF20	117
Sandy Brown 砂黄色	H 79 39	842	—	XF59	93
Tire Black 胎黑色	H 77 137	—	—	—	—
Metal Black 黑铁色	H 18 28	864	1402	—	—
Flat Black 哑光黑	H 12 33	950	1749	XF1	33

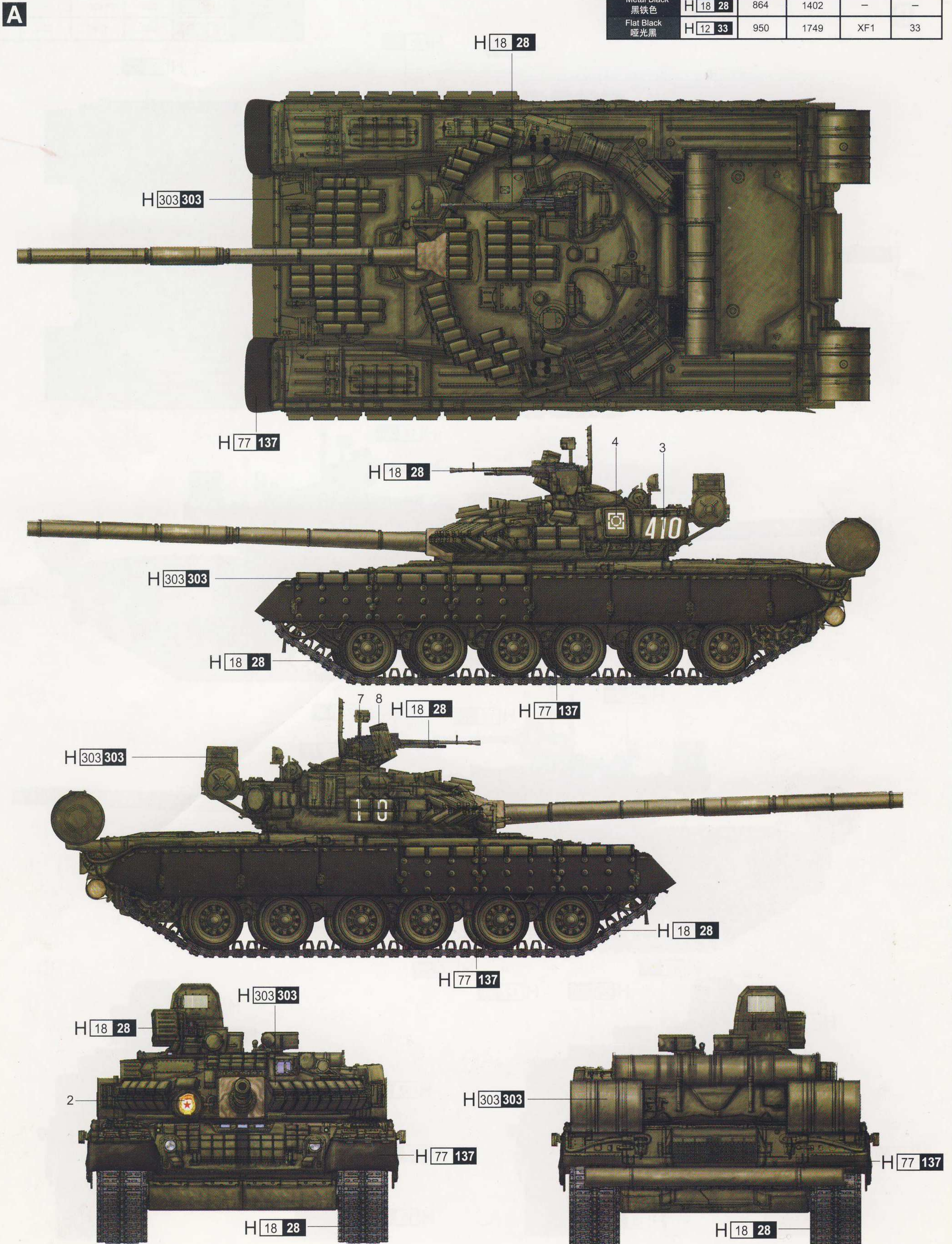

H AQUEOUS HOBBY COLOR ■ Mr. COLOR