

Italian Autocannone 3Ro with 90/53 90mm Anti-Aircraft Gun



Cat. No. 35063
Scale 1/35



3d design: Przemysław Głogowski
Research: IBG Crew



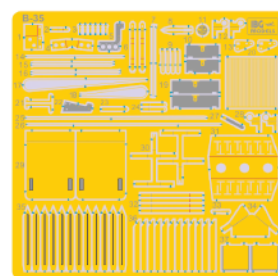

IBG Models would like to thank
Mr. Leonardo Landi for great help
in creating this model.

Elementy Fototrawione / Photo-etched Parts



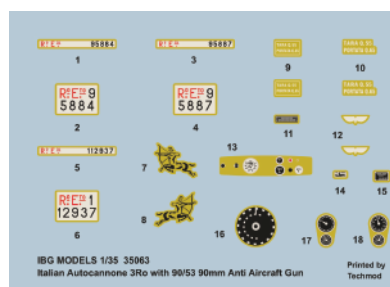

Kalkomanie / Decals



- 

Element złożony we wcześniejszym etapie
Element assembled in previous step
- 

Element po złożeniu w aktualnym etapie
Element after assembly in current step
- 

Wersja do wyboru
Version to choose
- 

Kolor farby
Paint colour
- 

Kalkomania
Decal

		VALLEJO MODEL AIR	HATAKA	LIFE COLOR	MR HOBBY	AK INTERACTIVE	MISSION MODELS
Saharian Khaki	A	71.023	HTK-_126	TM002	H341	AK007	MMP-016
Leather Brown	B	71.038	HTK-_186	UA764	H047	AK3031	MMP-002
Black	C	71.057	HTK-_100	UA733	H077	RC022	MMP-047
Rust	D	71.080	HTK-_132	LC32	H47	AK708	MMW-001
Gunmetal	E	71.072	HTK-_106	LC26	H018	AK798	MMM-010
Wood	F	71.077	HTK-_172	UA714	H37	AK780	MMP-142

Przed montażem przeczytać instrukcję. Przestrzegać kolejności montażu podanego w instrukcji. Klej i farby nie wchodzi w skład zestawu.
Please read instructions before assembly. Follow the sequence of assembly presented in instructions. Glue and paint not included.

IBG Models
ul. Benedykta Hertza 2
04-603 Warszawa
Poland

tel +48 22 8159150
fax +48 22 8159151
ibgsc@ibg.com.pl
www.ibg.com.pl
www.ibgmodels.com

Elementy modelu
Elements of the model kit

Ramka A / Frame A

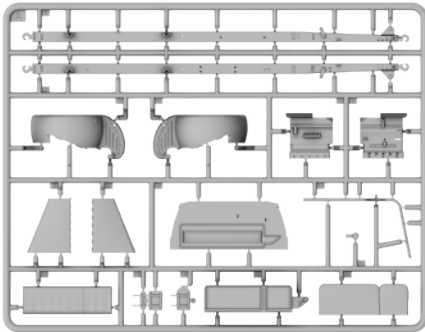

Ramka B / Frame B

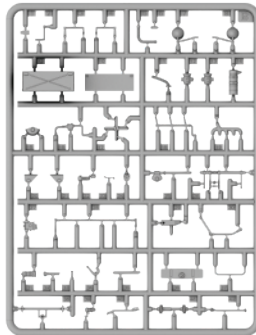

Ramka C / Frame C

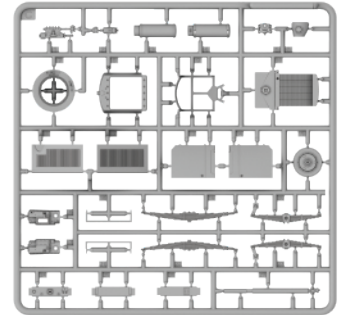

Ramka D / Frame D

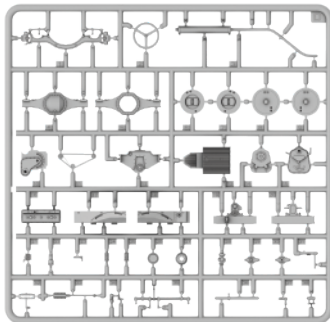

Ramka E / Frame E

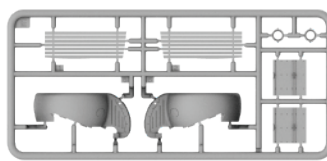

Ramka G / Frame G

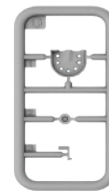

Ramka I / Frame I

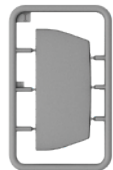

Ramka F x2 / Frame F x2

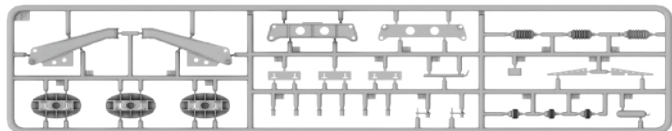

Ramka H x2 / Frame H x2

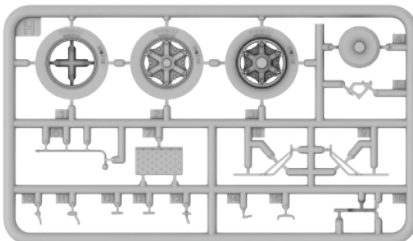

Opona x7 / Tire x7

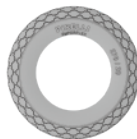

Ramka W / Frame W

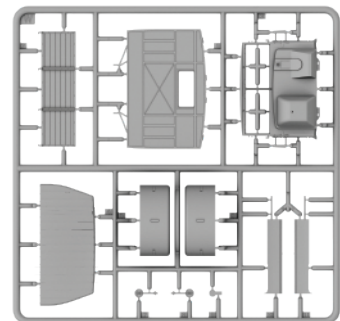

Ramka Q / Frame Q

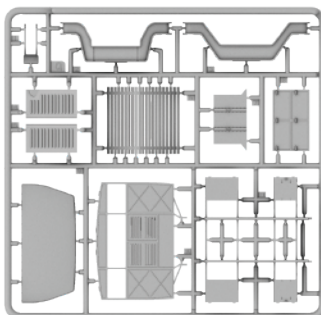

Ramka M przezroczysta
/ Frame M transparent

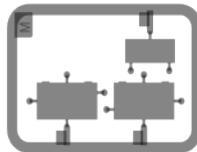

Ramka L przezroczysta
/ Frame L transparent



Ramka R / Frame R

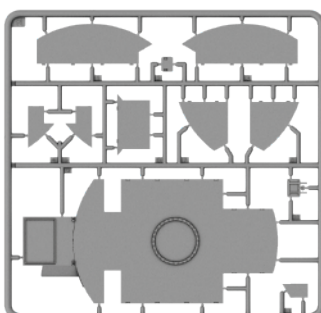

Ramka T / Frame T

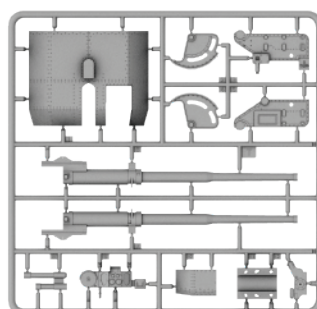

Ramka U / Frame U

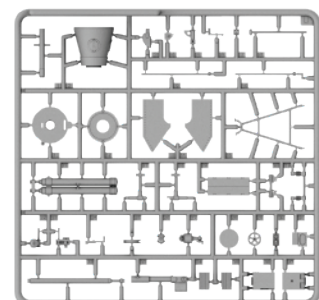

Etap 1
Step 1

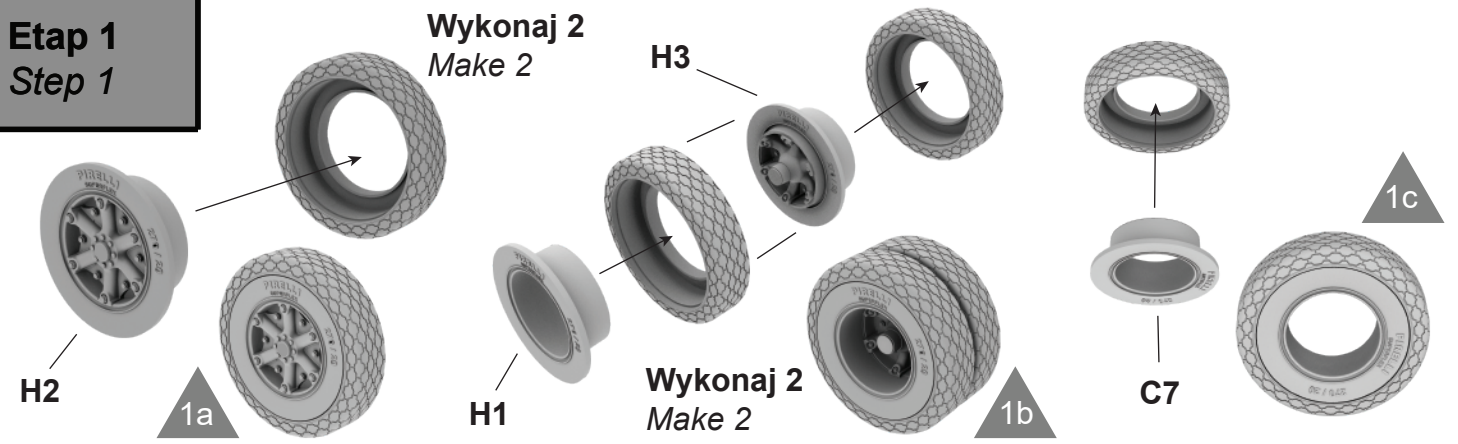

Etap 2
Step 2

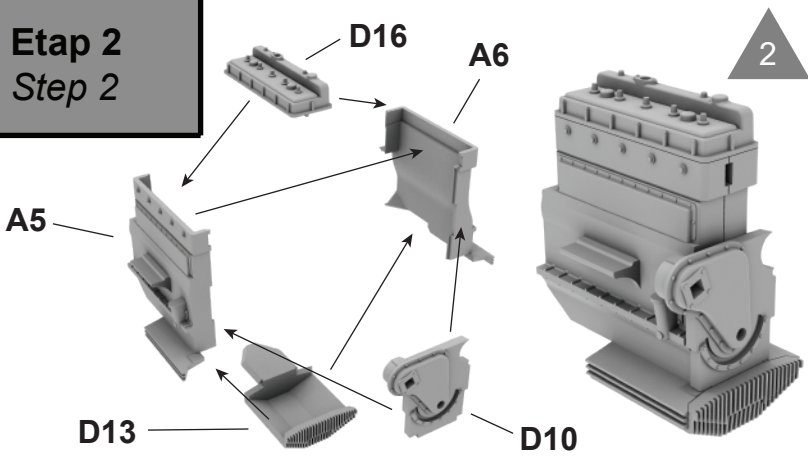

Etap 3
Step 3

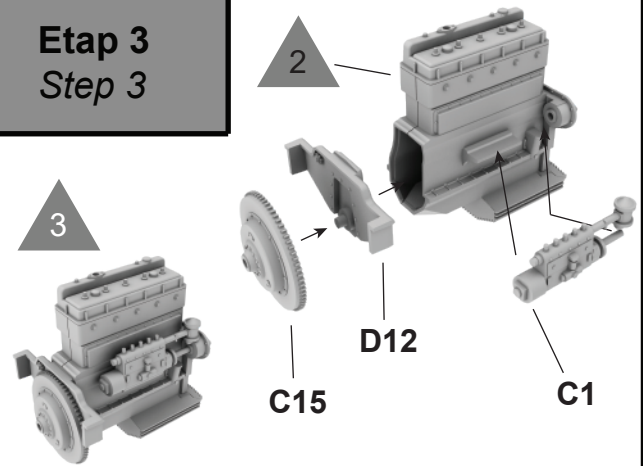

Etap 4
Step 4

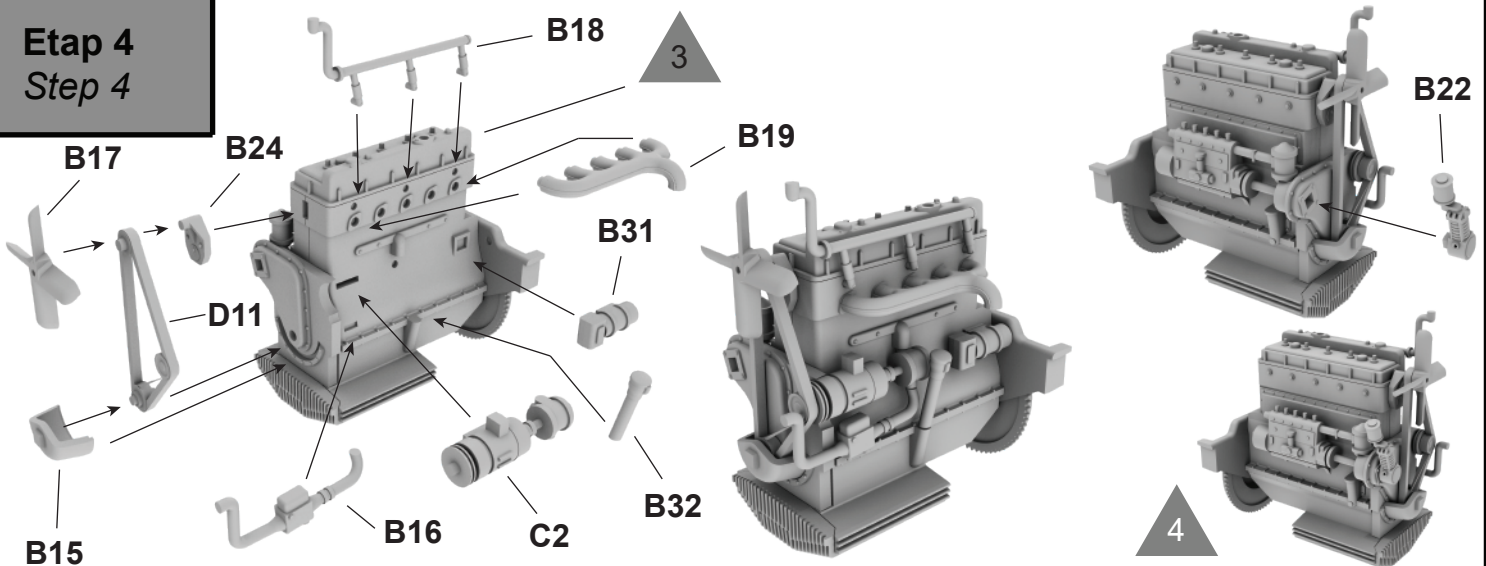

Etap 5
Step 5

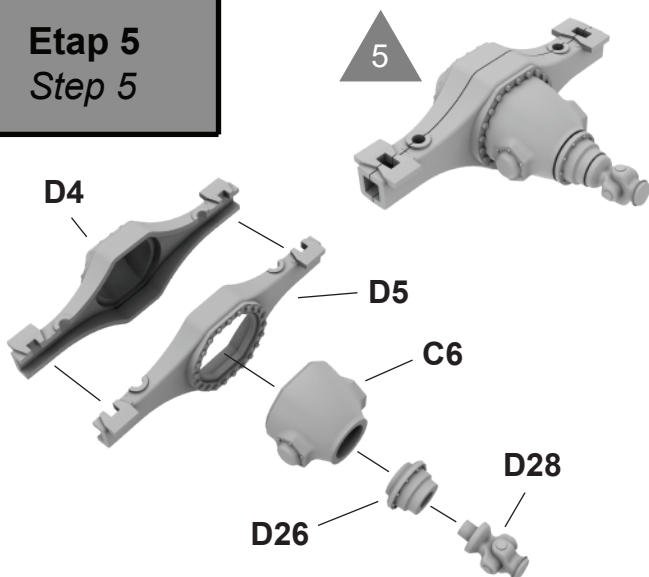

Etap 6
Step 6

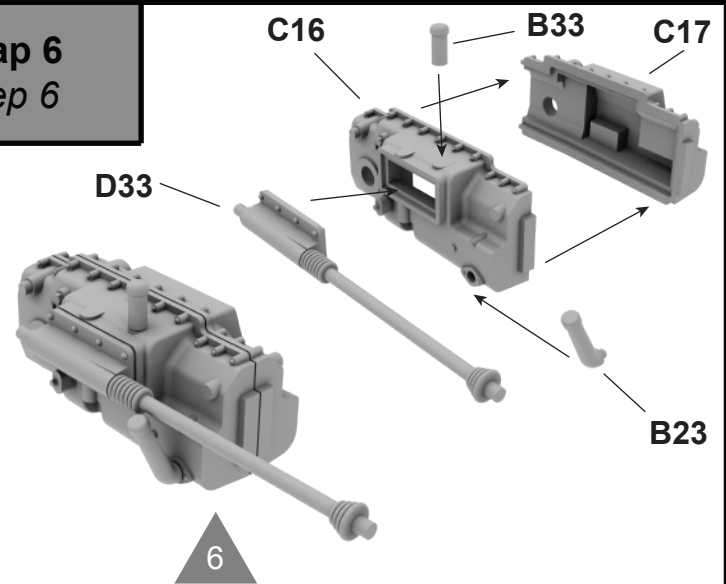

Etap 7
Step 7

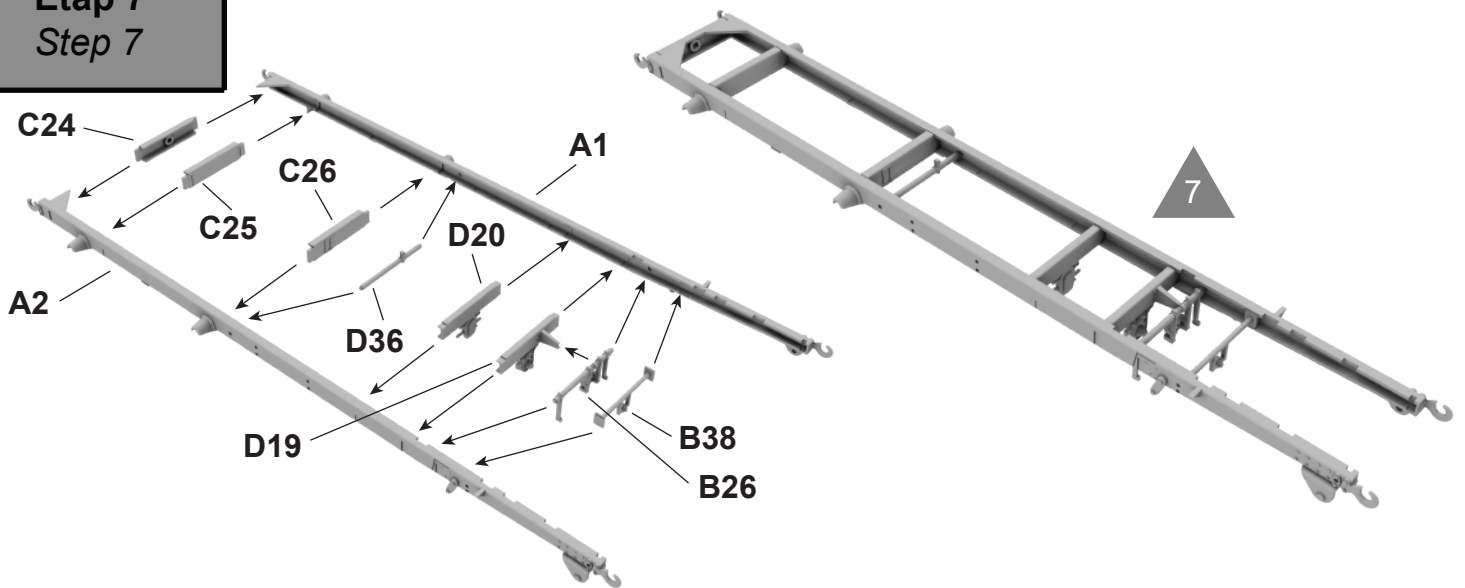

Etap 8
Step 8

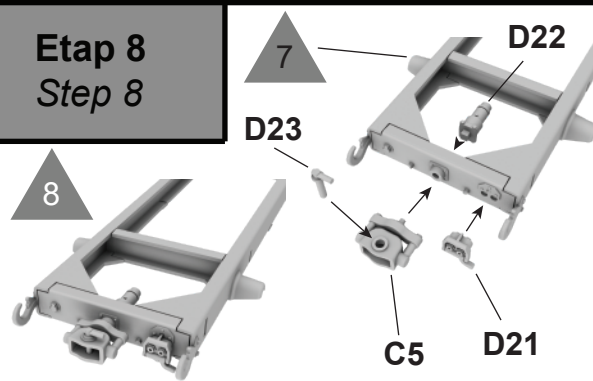

Etap 9
Step 9

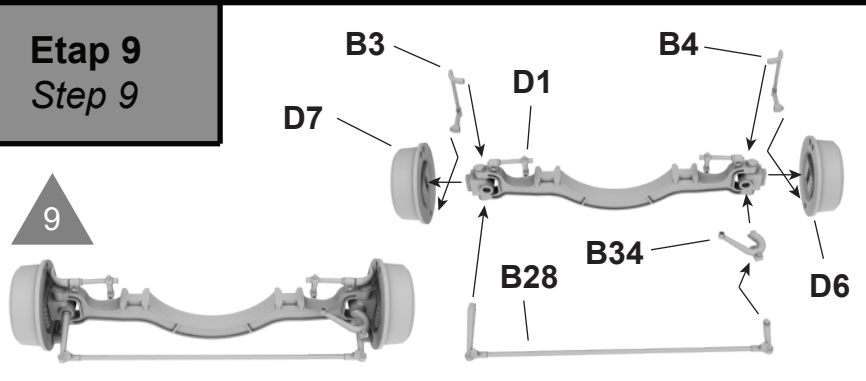

Etap 10
Step 10

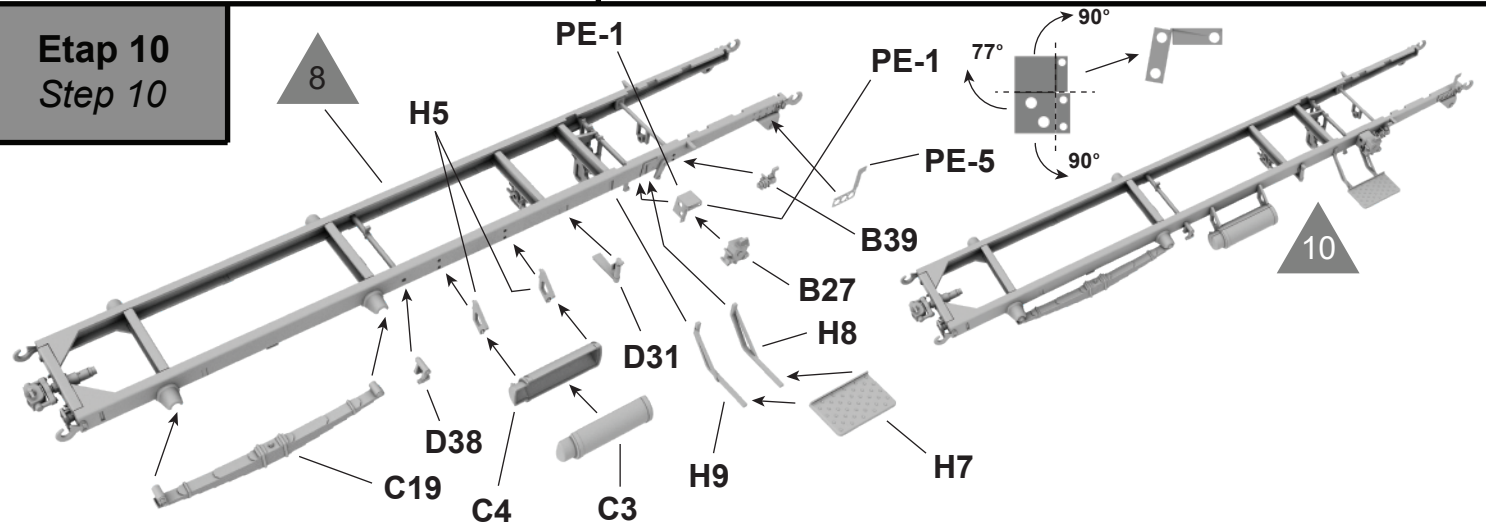

Etap 11
Step 11

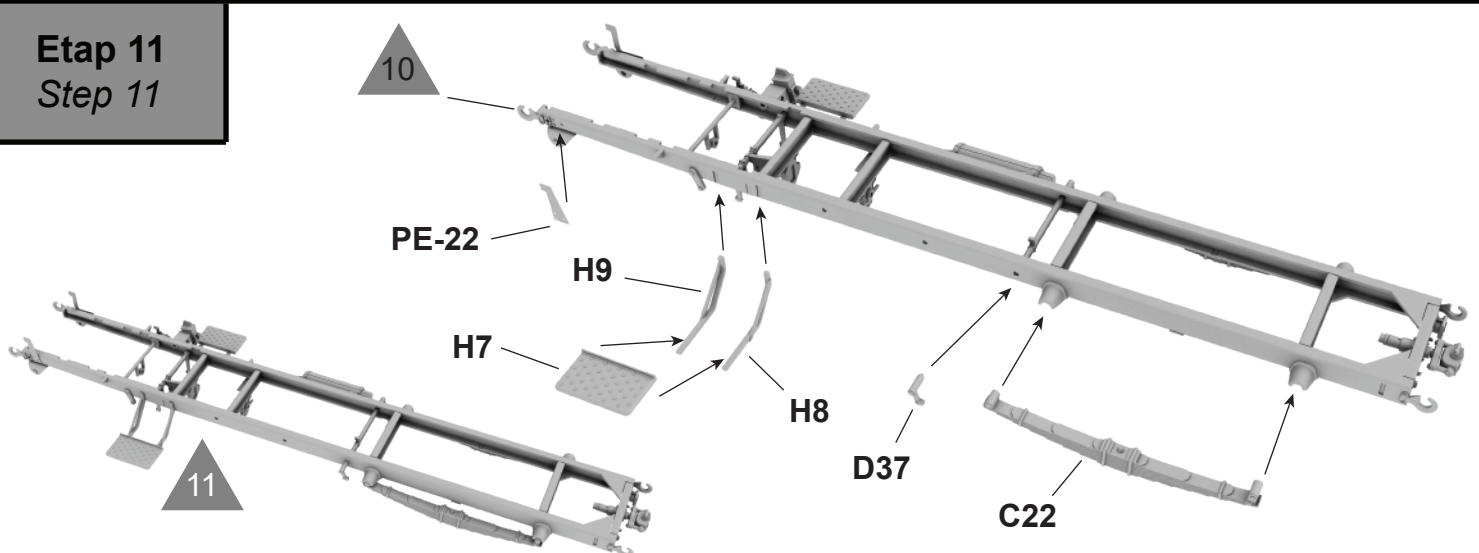

Etap 12
Step 12

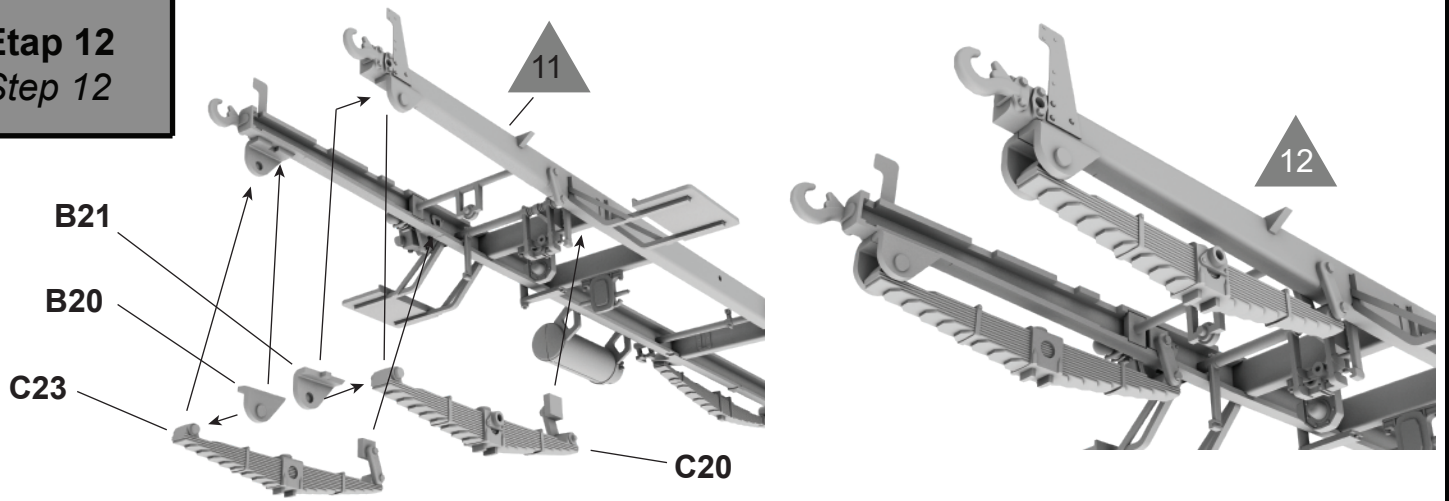

Etap 13
Step 13

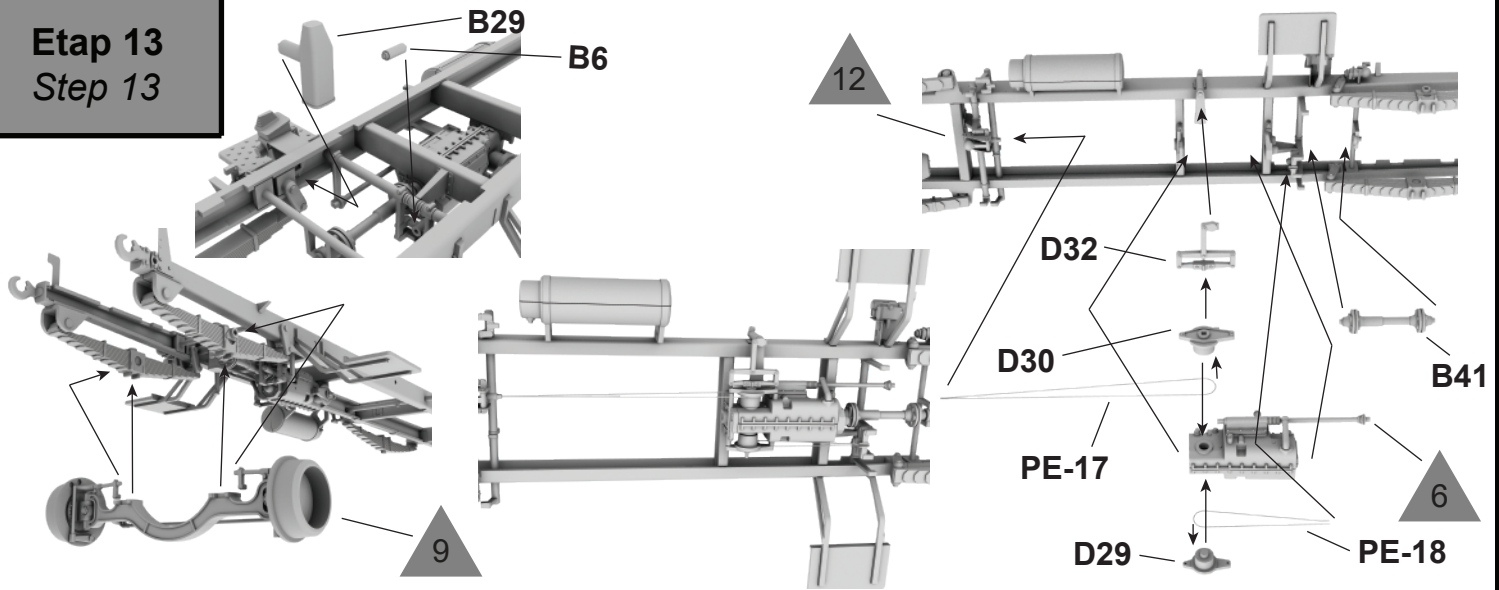

Etap 14
Step 14

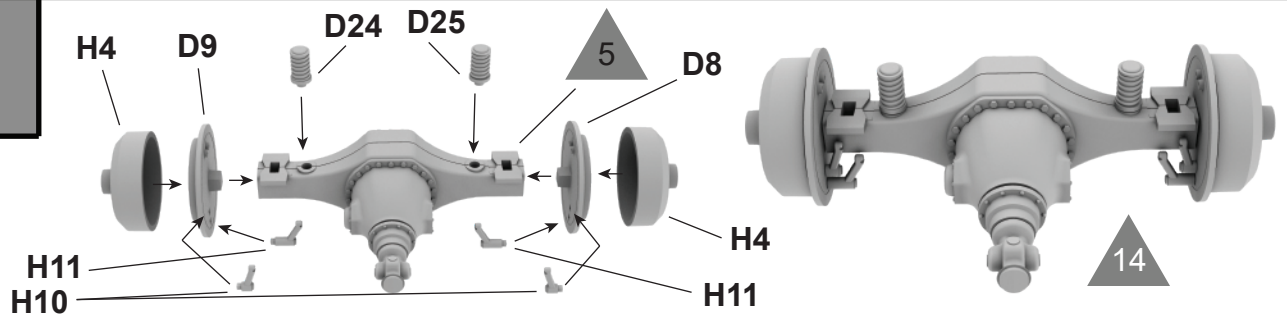

Etap 15
Step 15

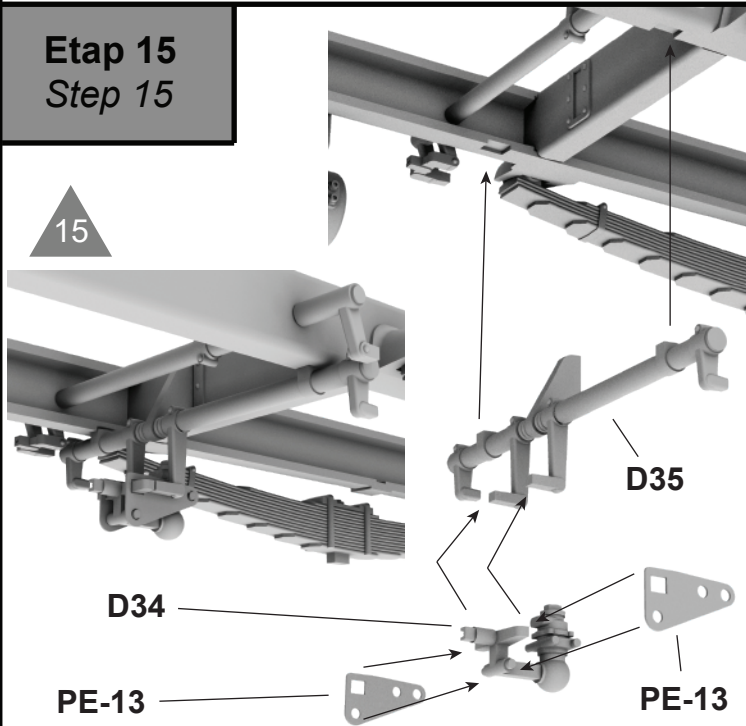

Etap 16
Step 16

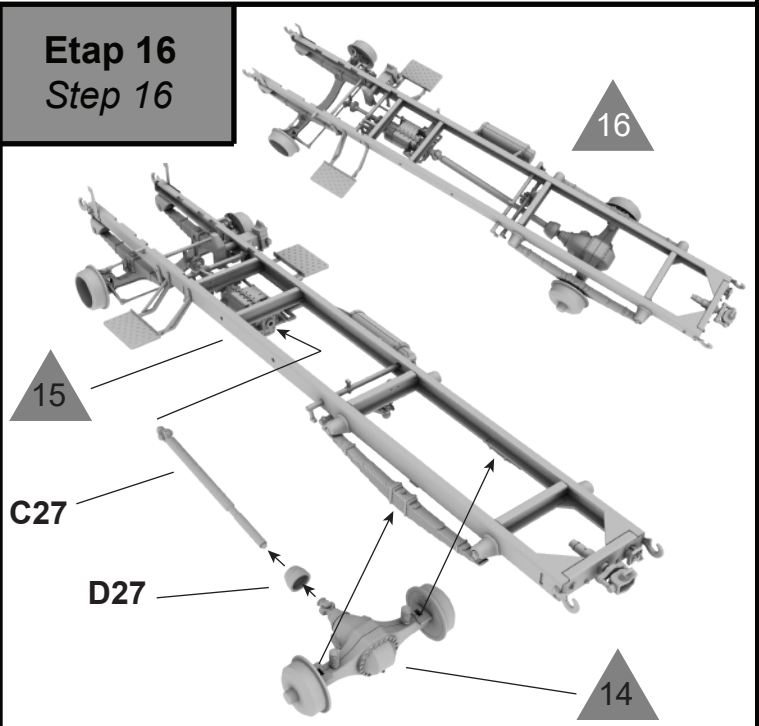

Etap 17
Step 17

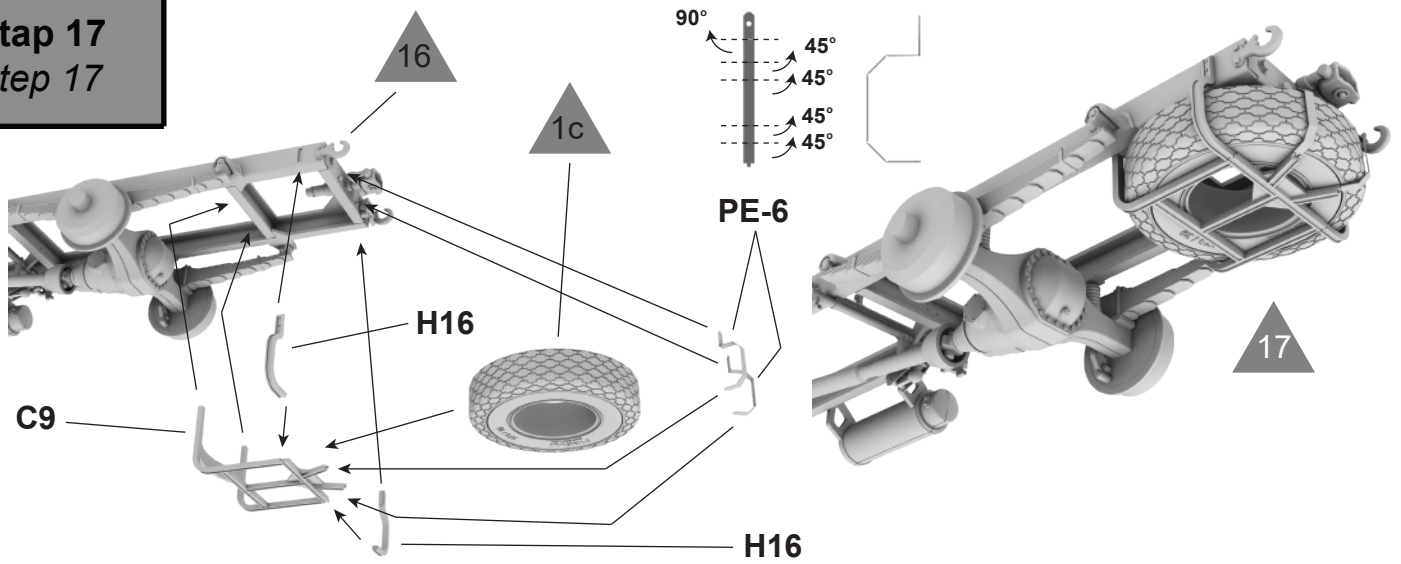

Etap 18
Step 18

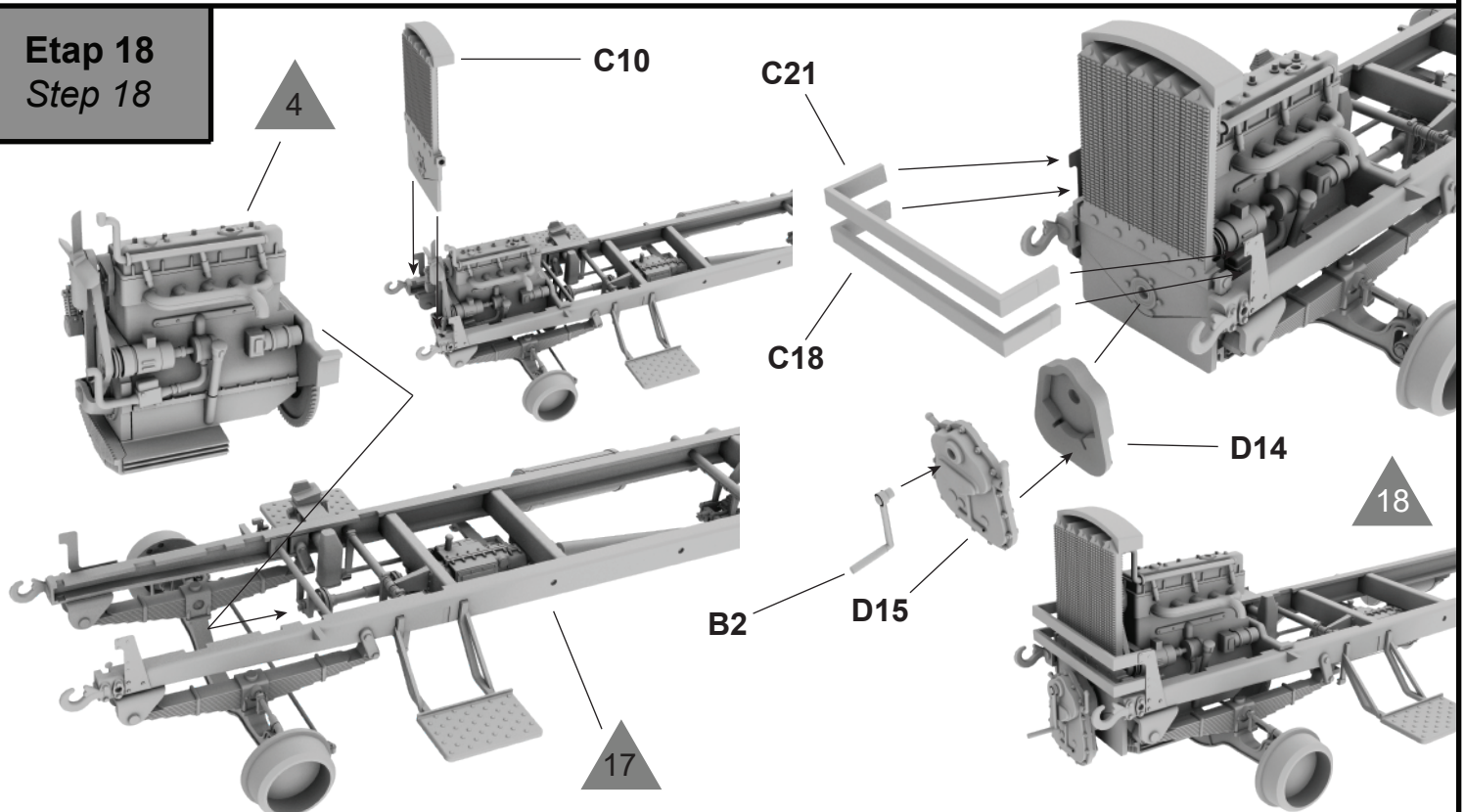

Etap 19
Step 19

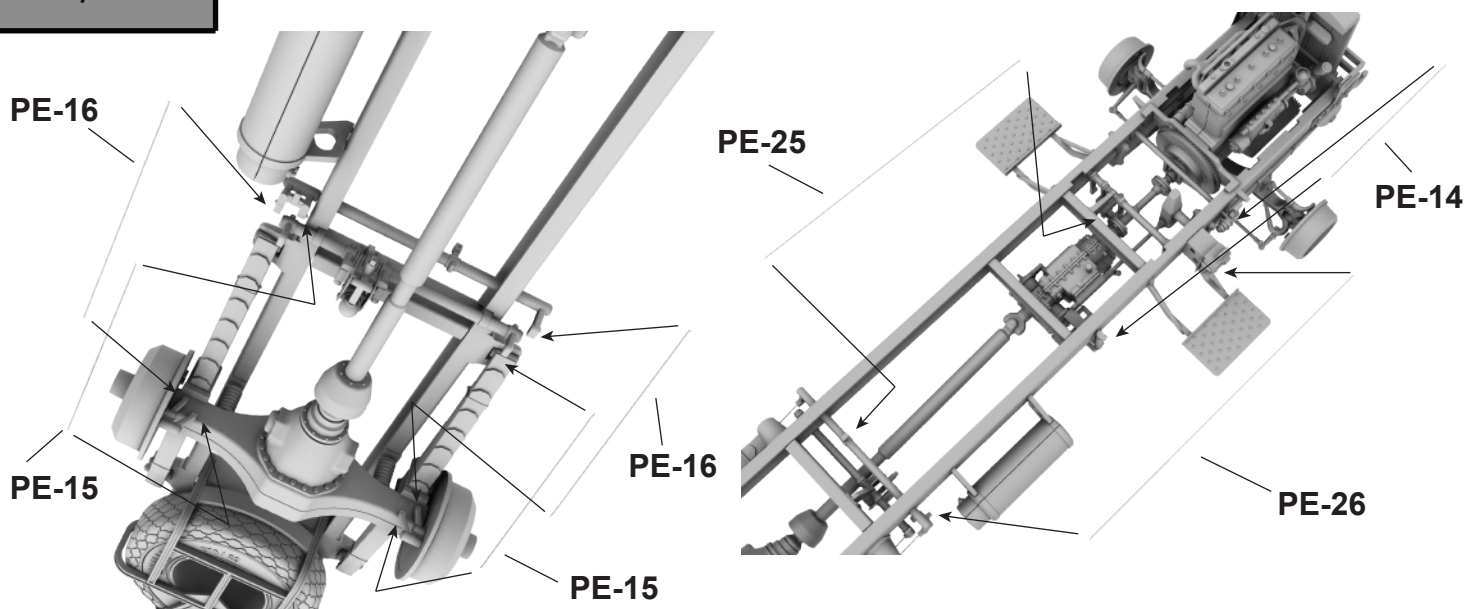

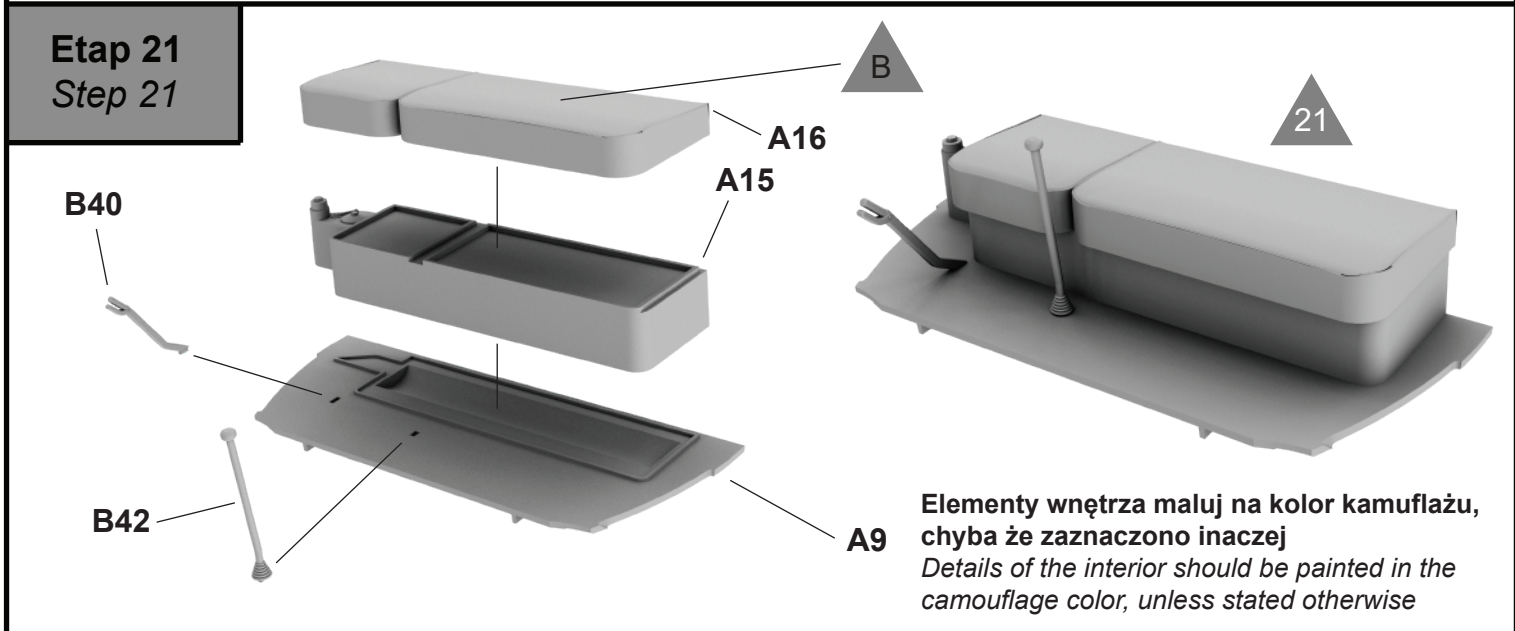
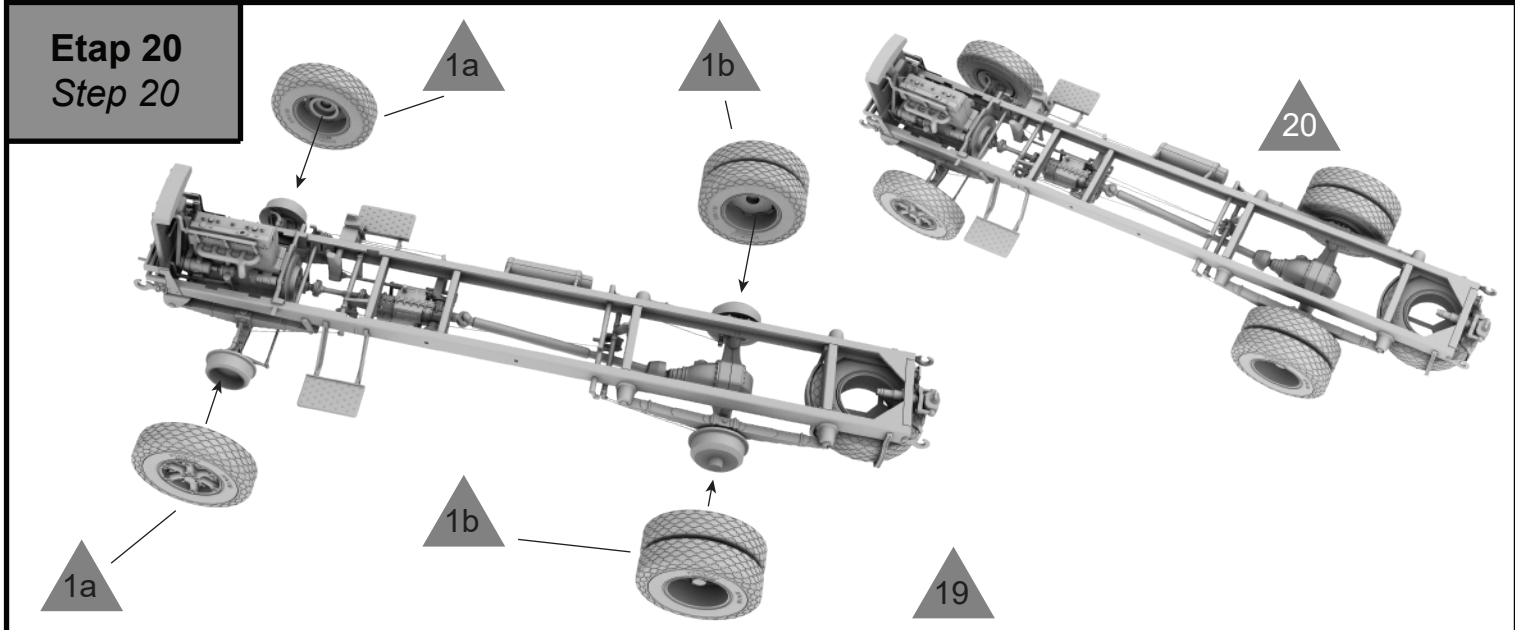
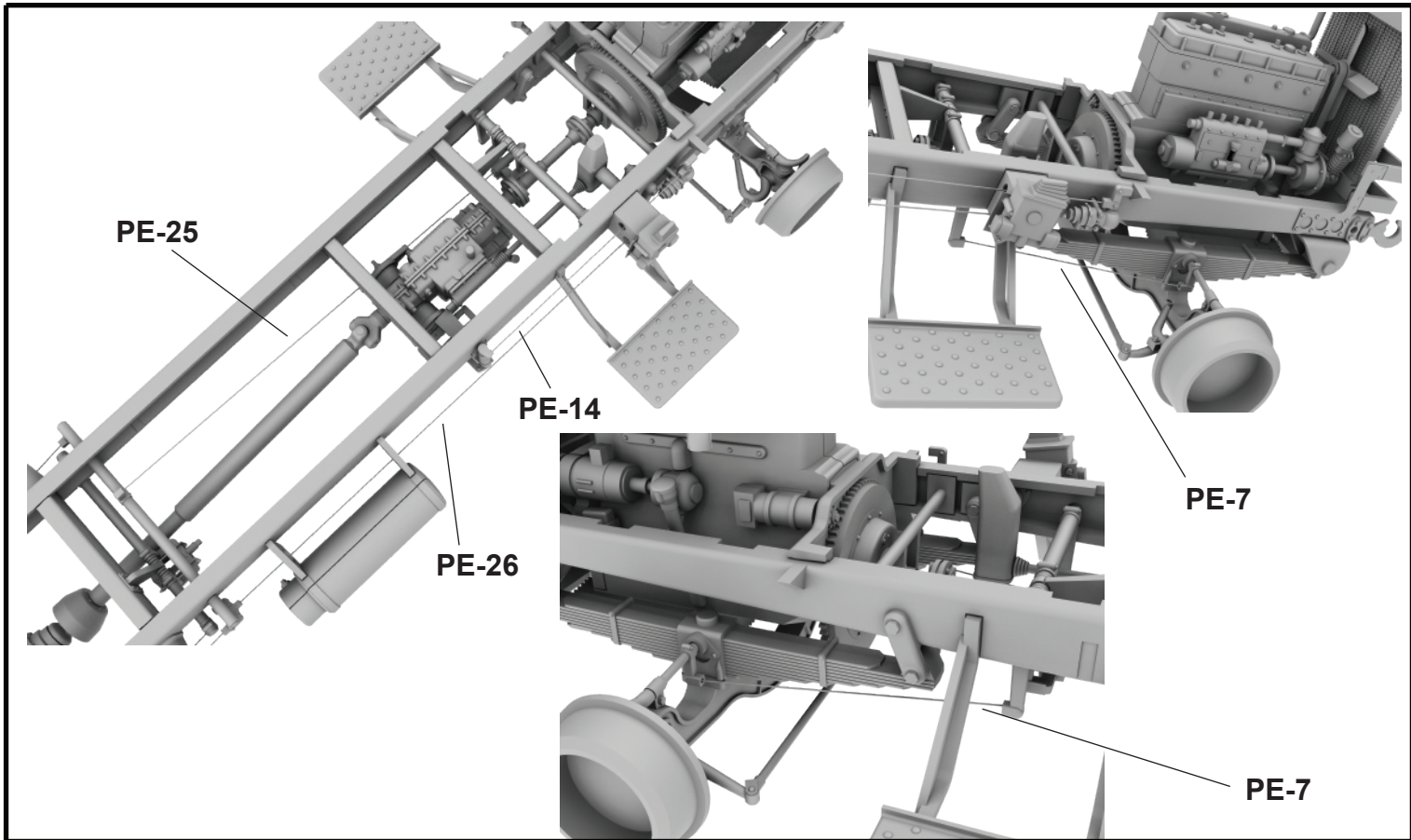

Etap 22
Step 22

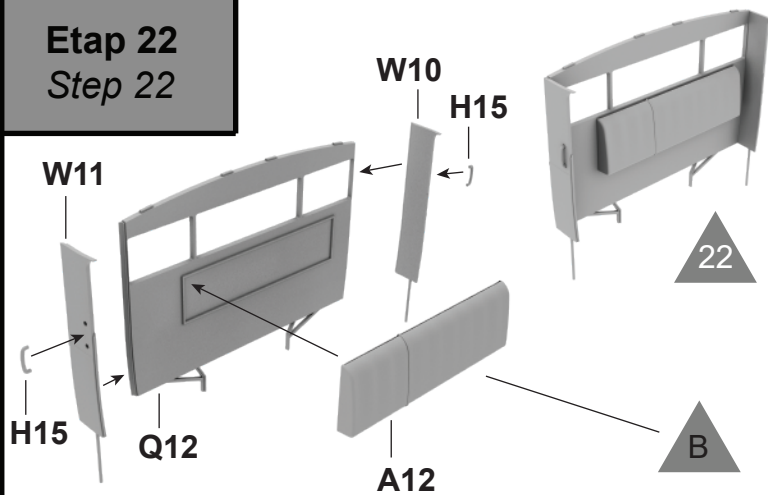

Etap 23
Step 23

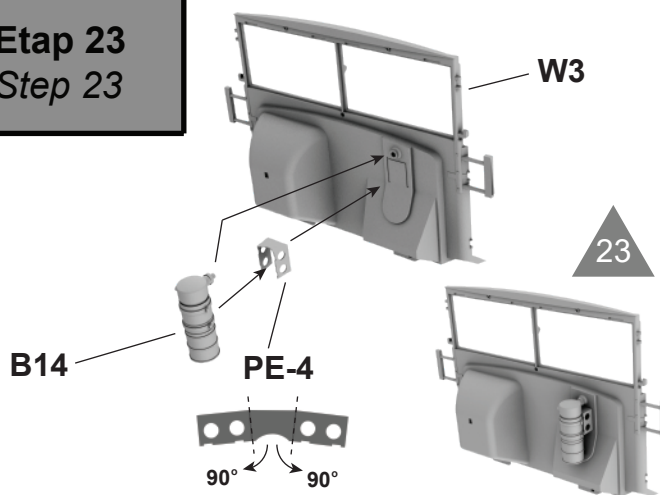

Etap 24
Step 24

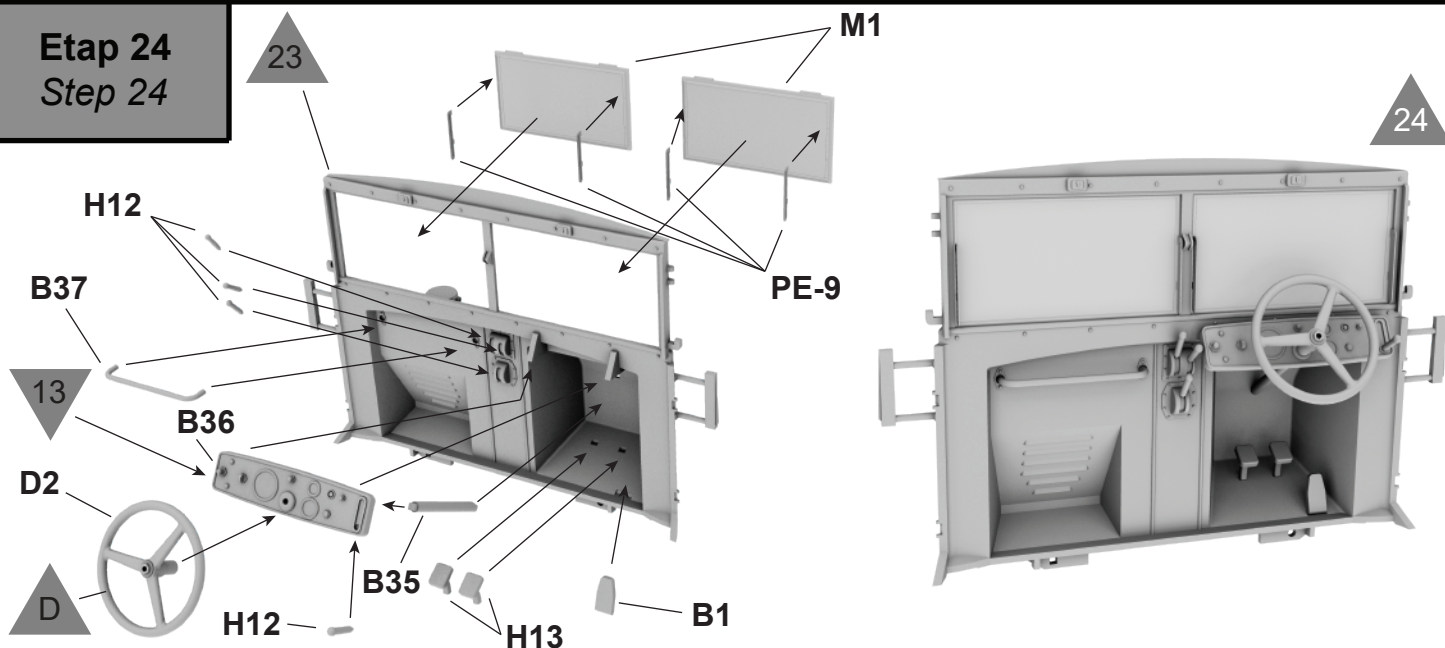

Etap 25
Step 25

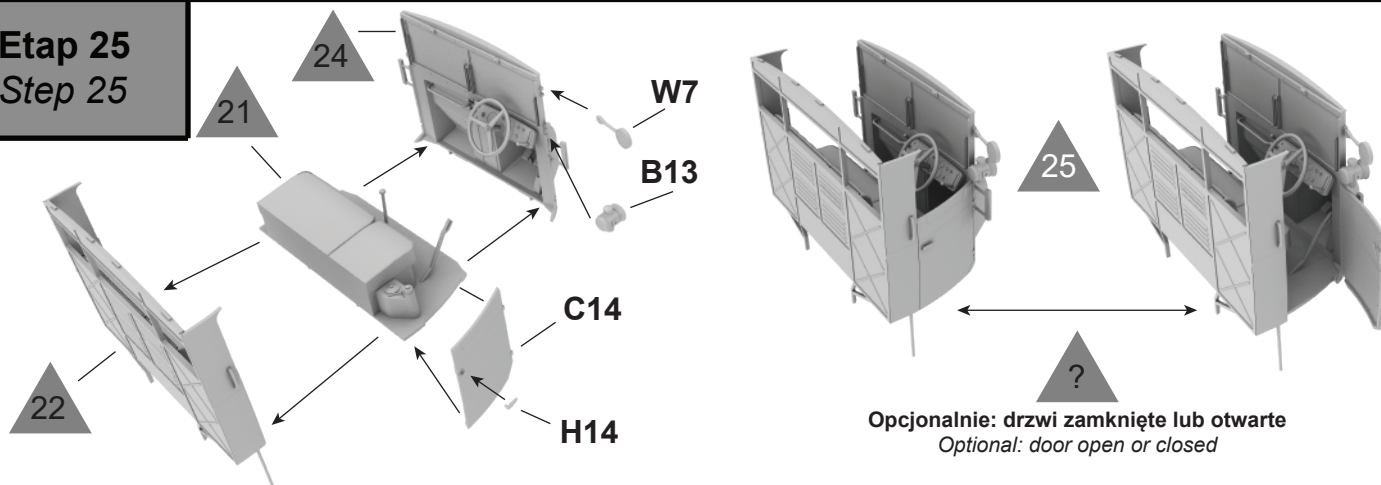

Opcjonalnie: drzwi zamknięte lub otwarte
Optional: door open or closed

Etap 26
Step 26

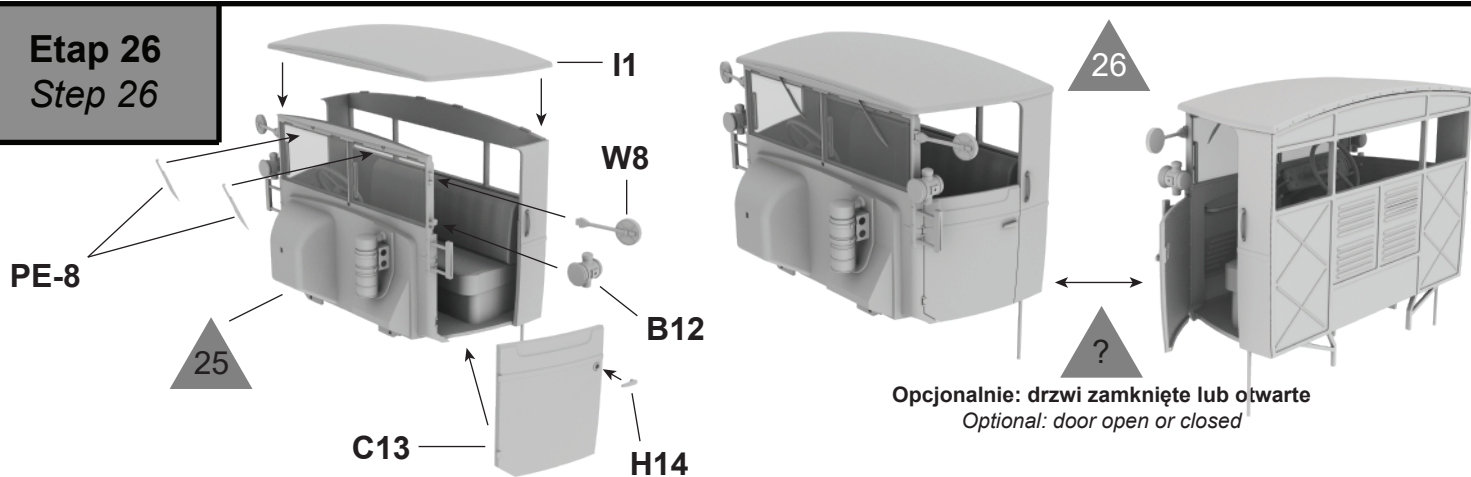

Opcjonalnie: drzwi zamknięte lub otwarte
Optional: door open or closed

Etap 27
Step 27

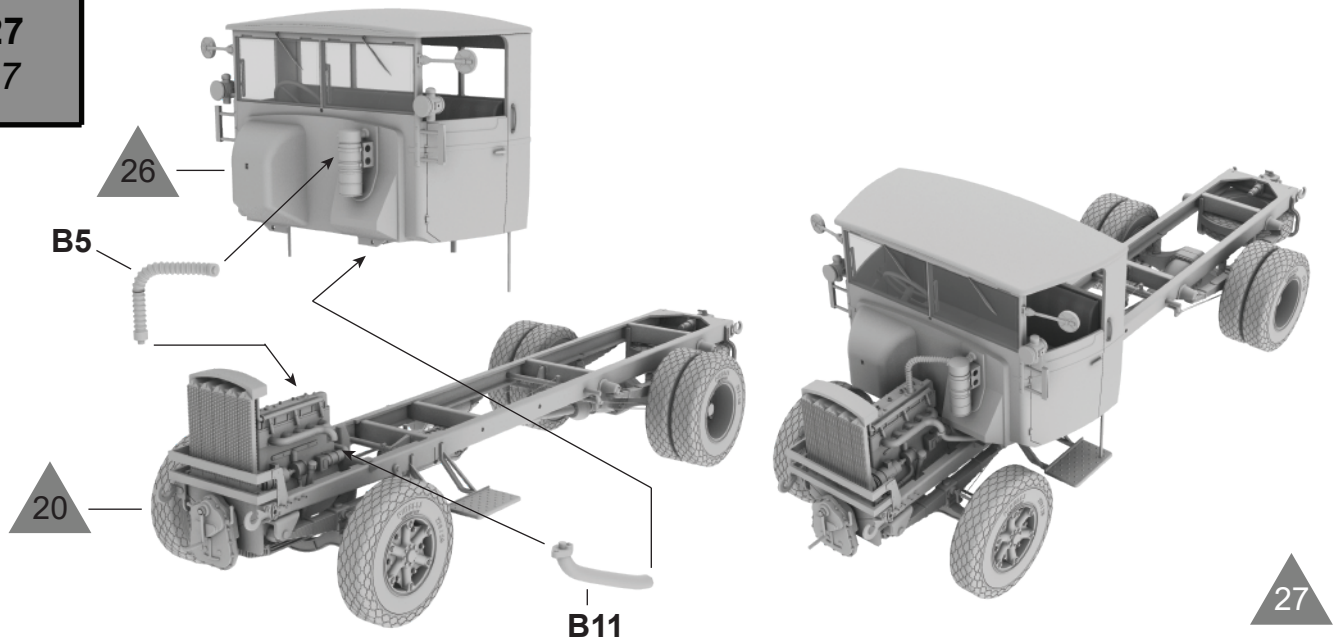

Etap 28
Step 28

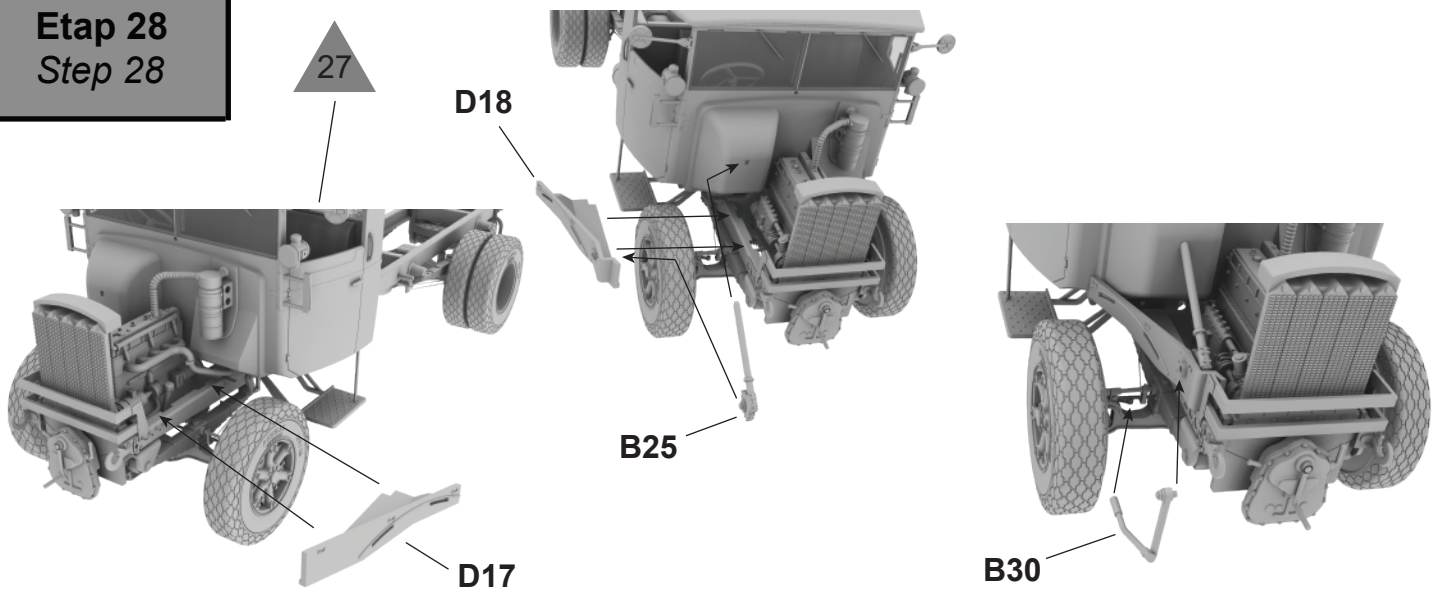

Etap 29
Step 29

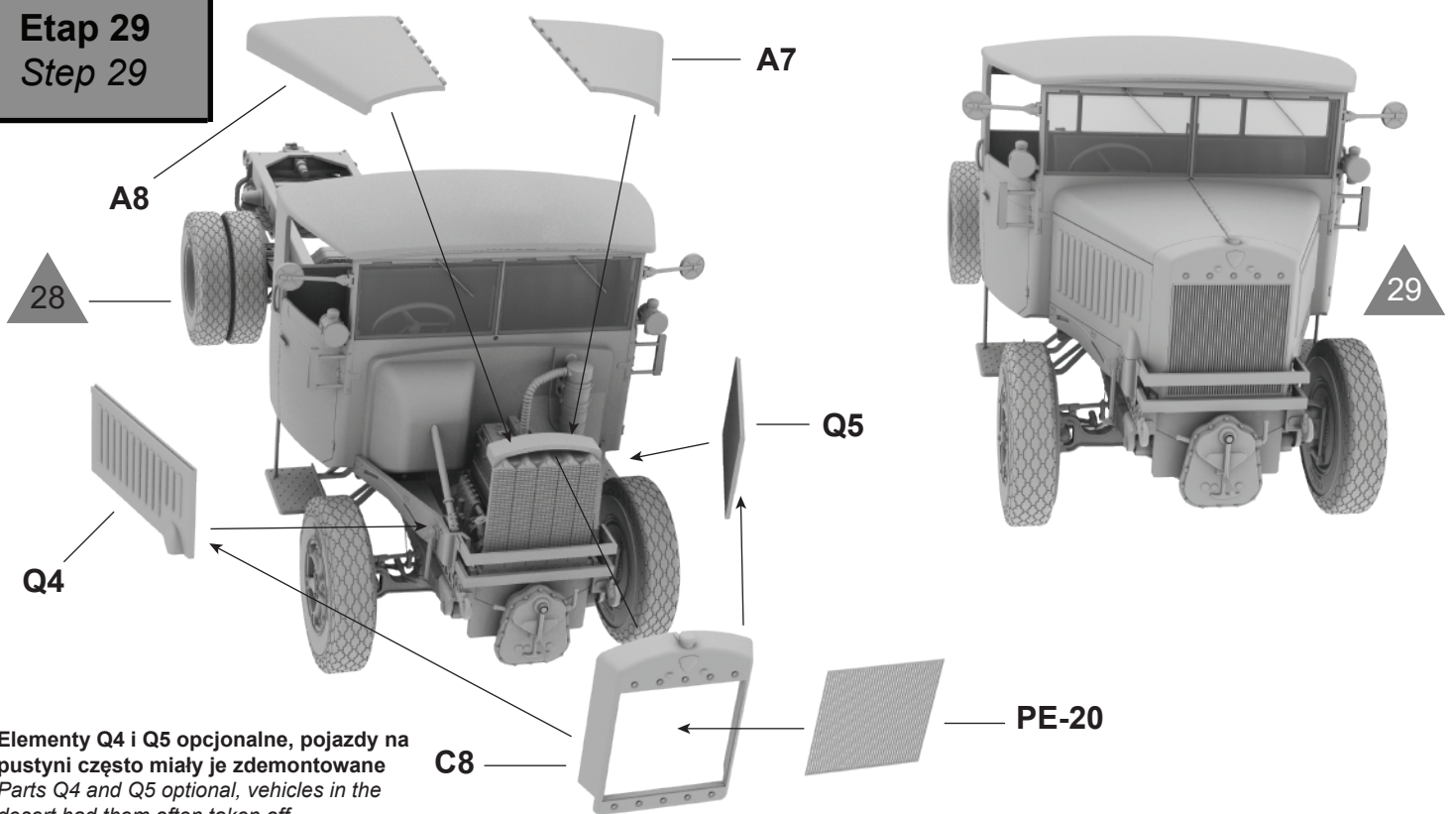

Elementy Q4 i Q5 opcjonalne, pojazdy na pustyni często miały je zdemontowane
Parts Q4 and Q5 optional, vehicles in the desert had them often taken off

Etap 30
Step 30

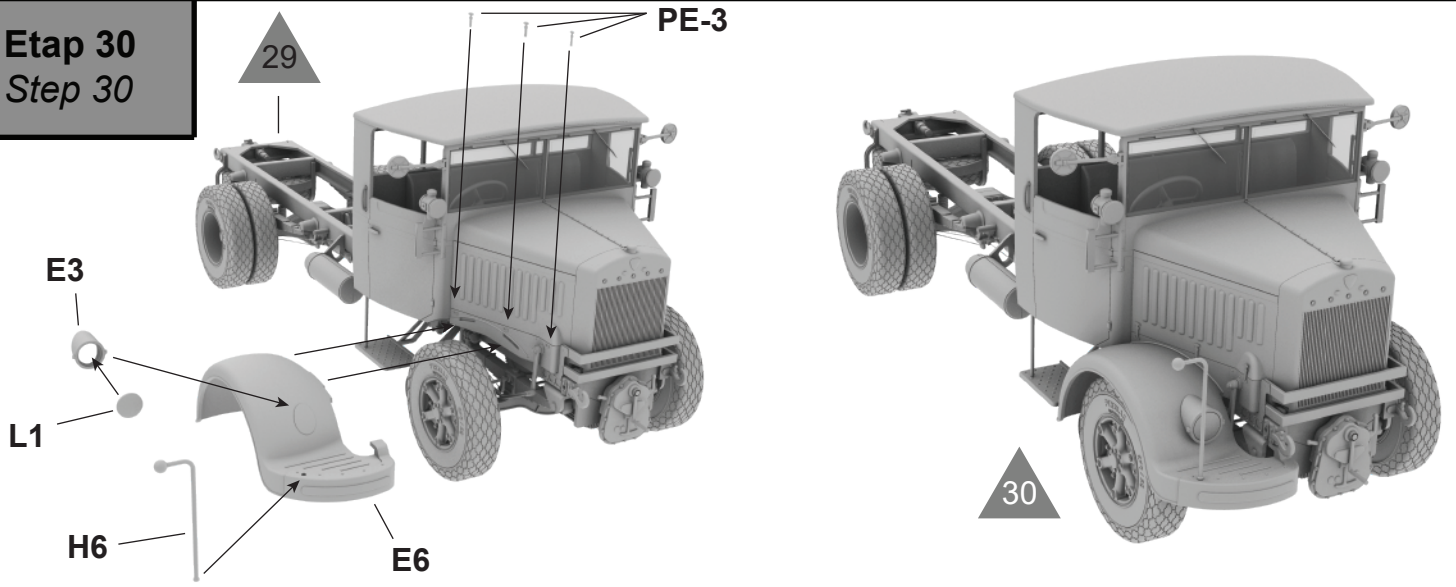

Etap 31
Step 31

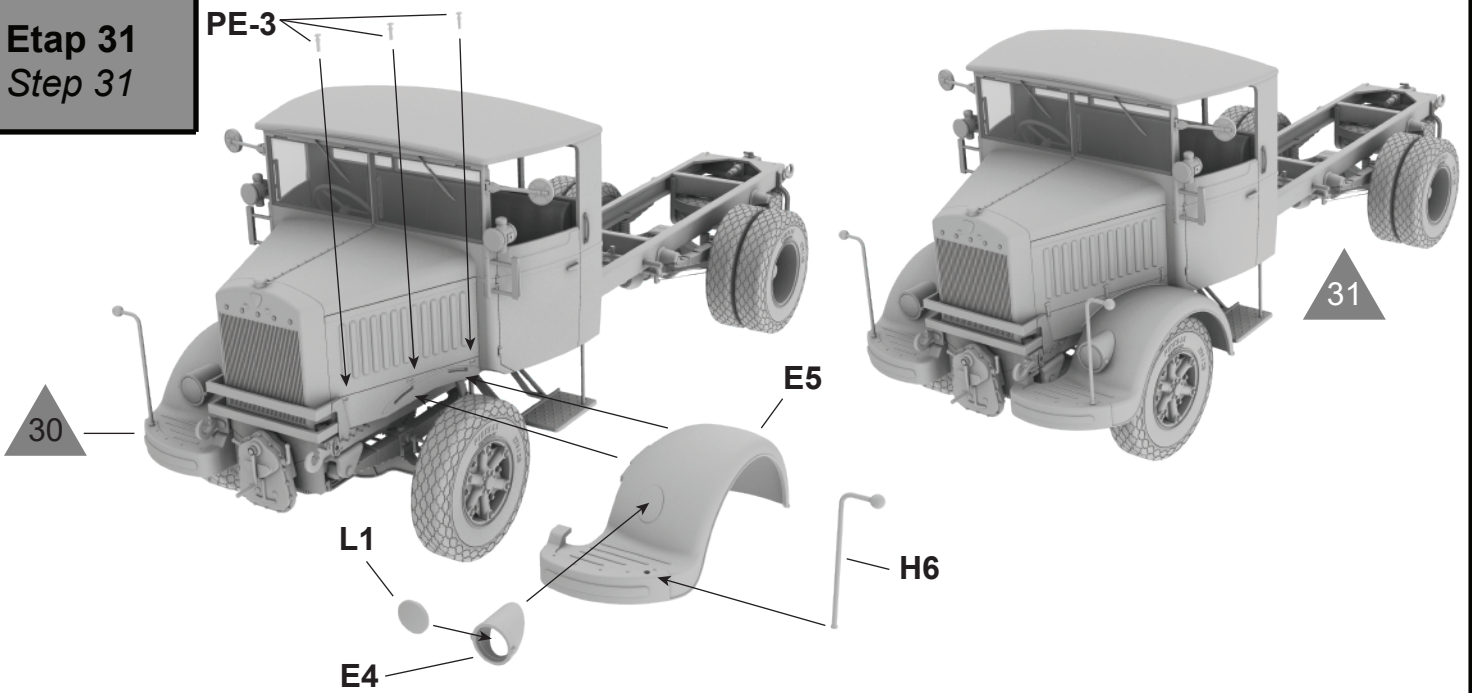

Etap 32
Step 32

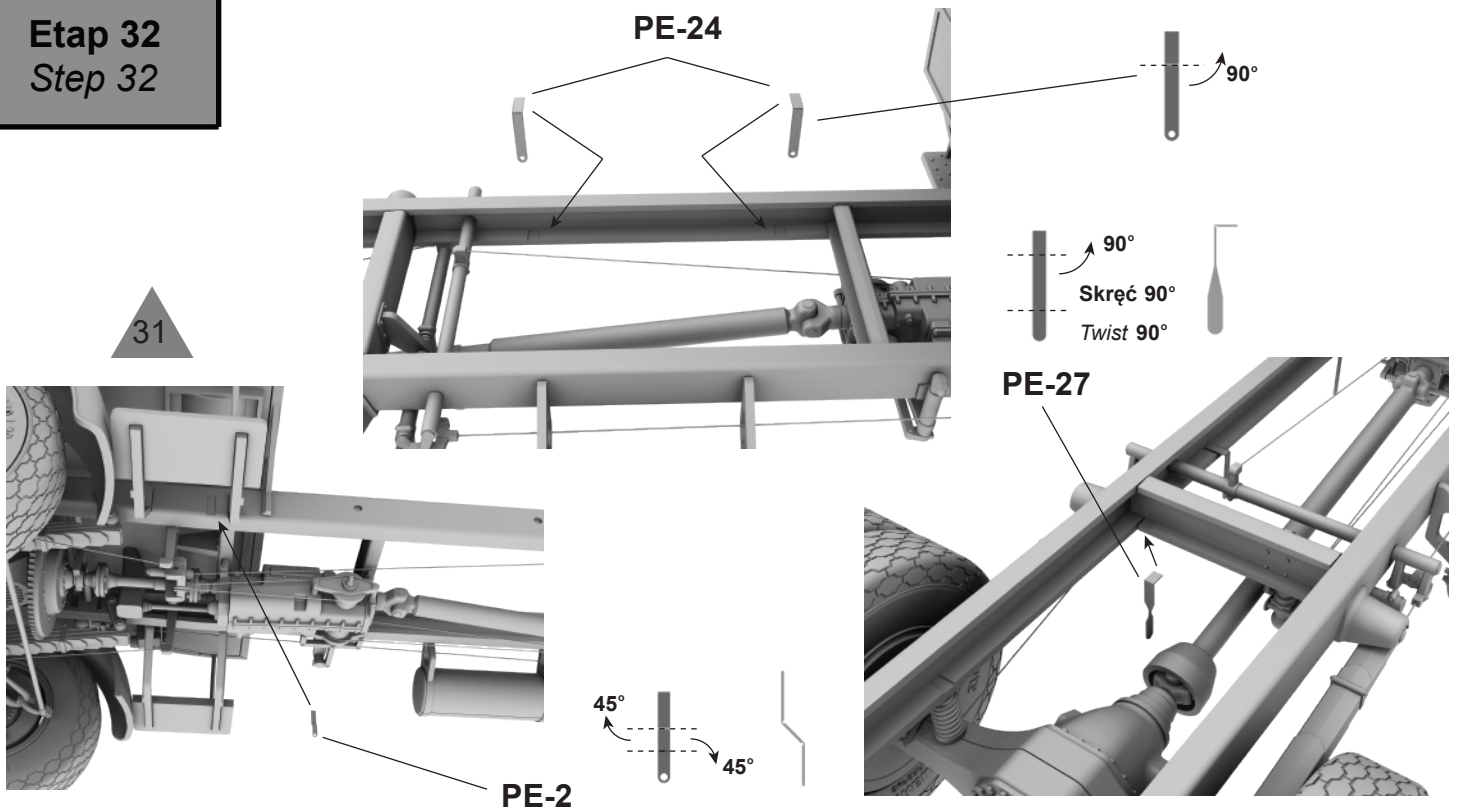

Etap 33
Step 33

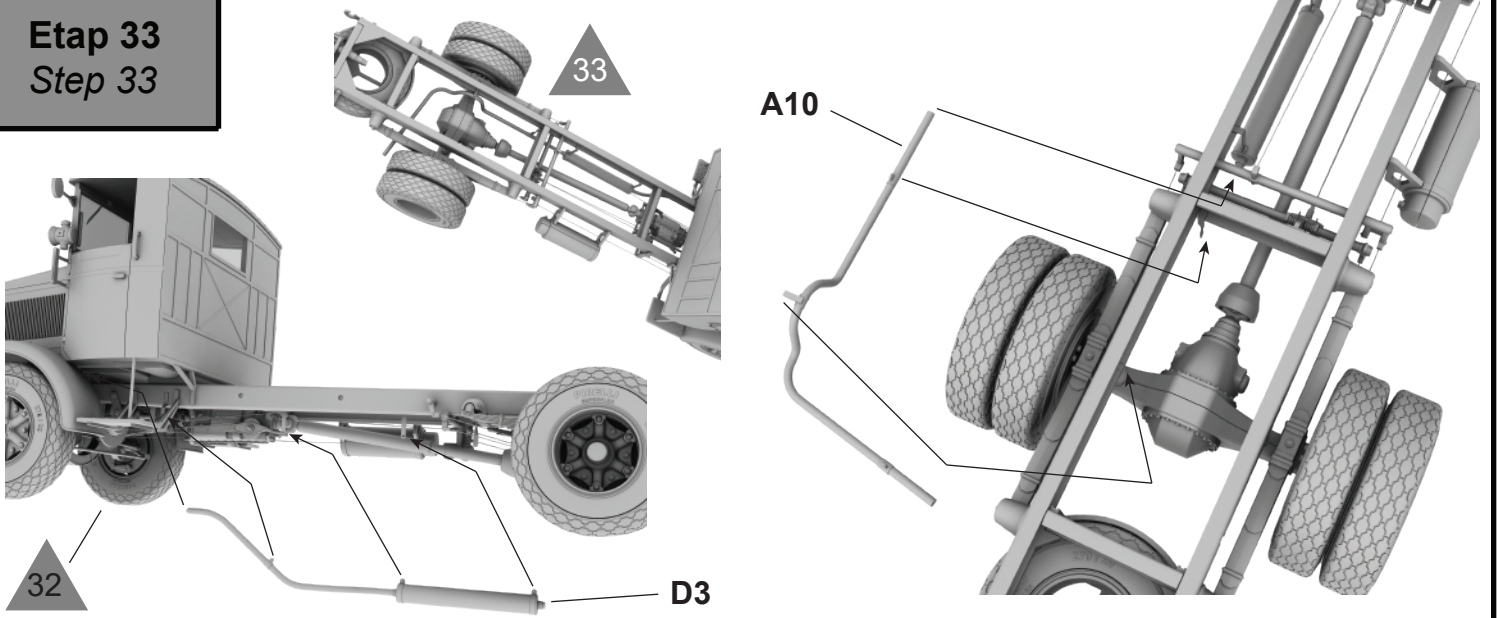

Etap 34
Step 34

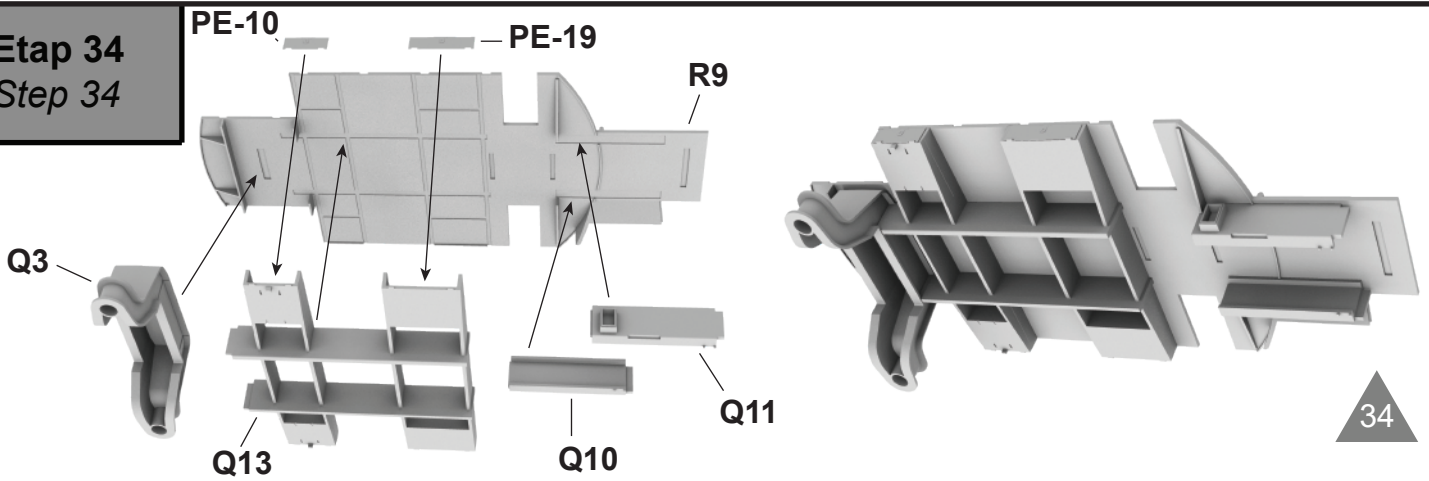

Etap 35
Step 35

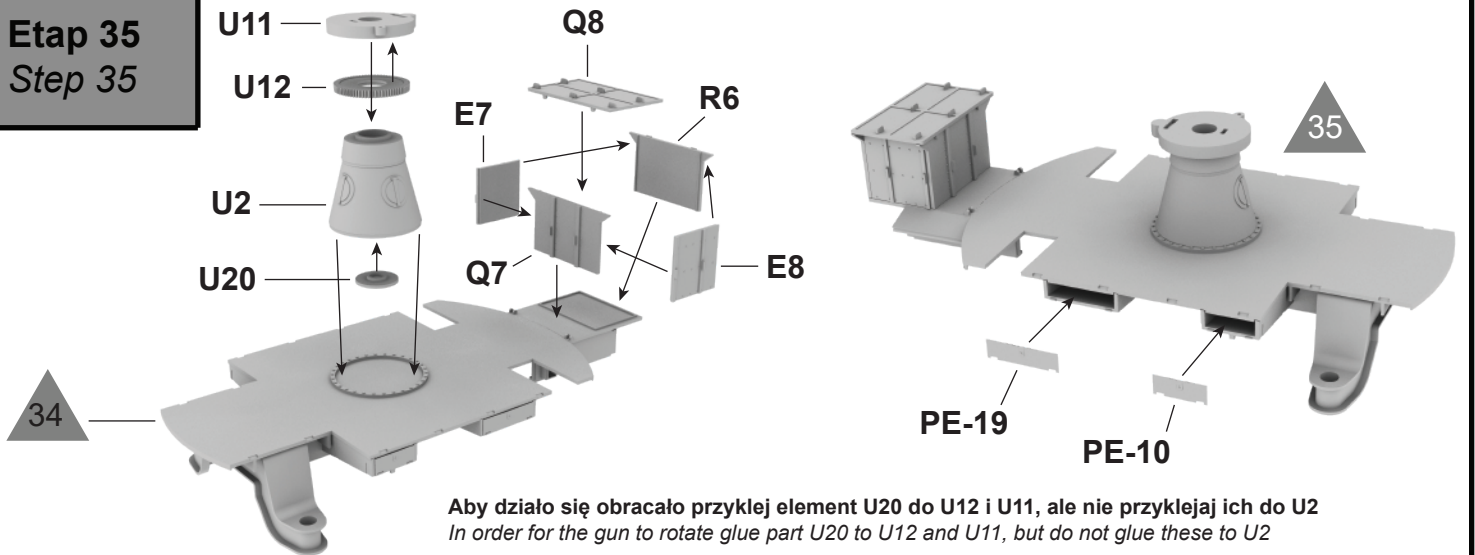

Etap 36
Step 36

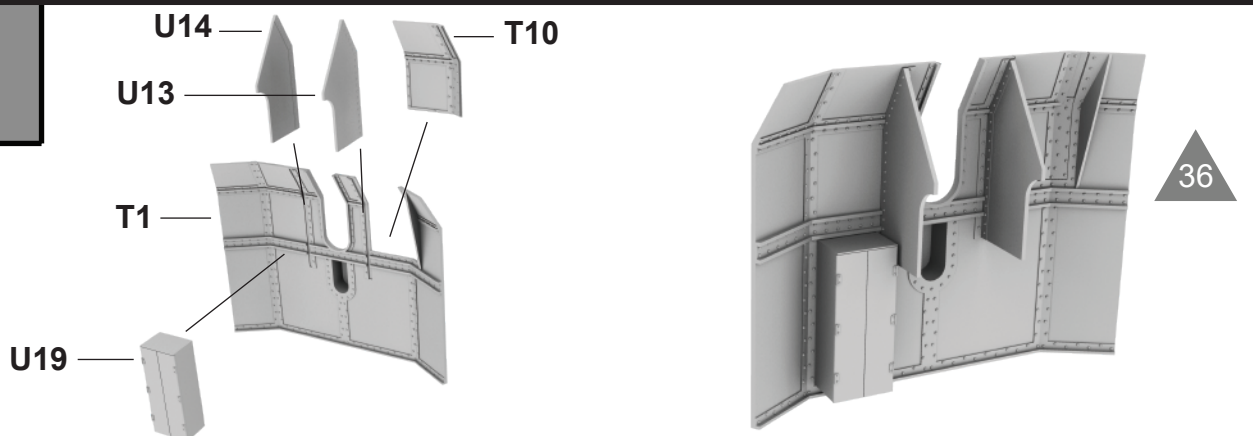

Etap 37
Step 37

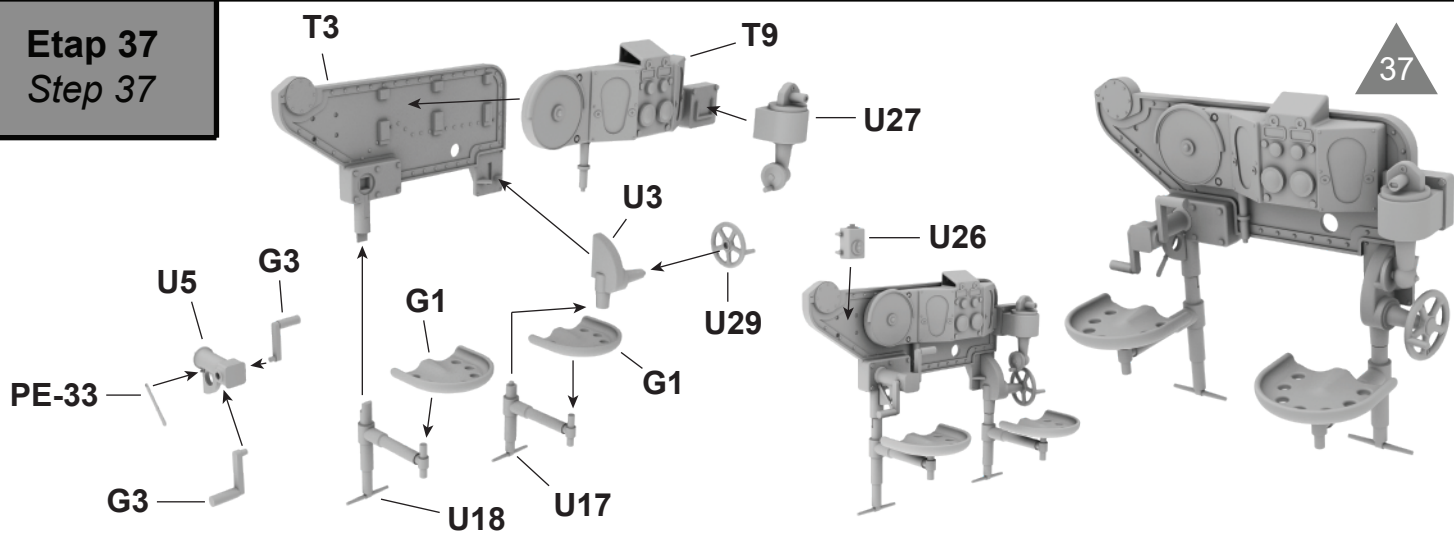

Etap 38
Step 38

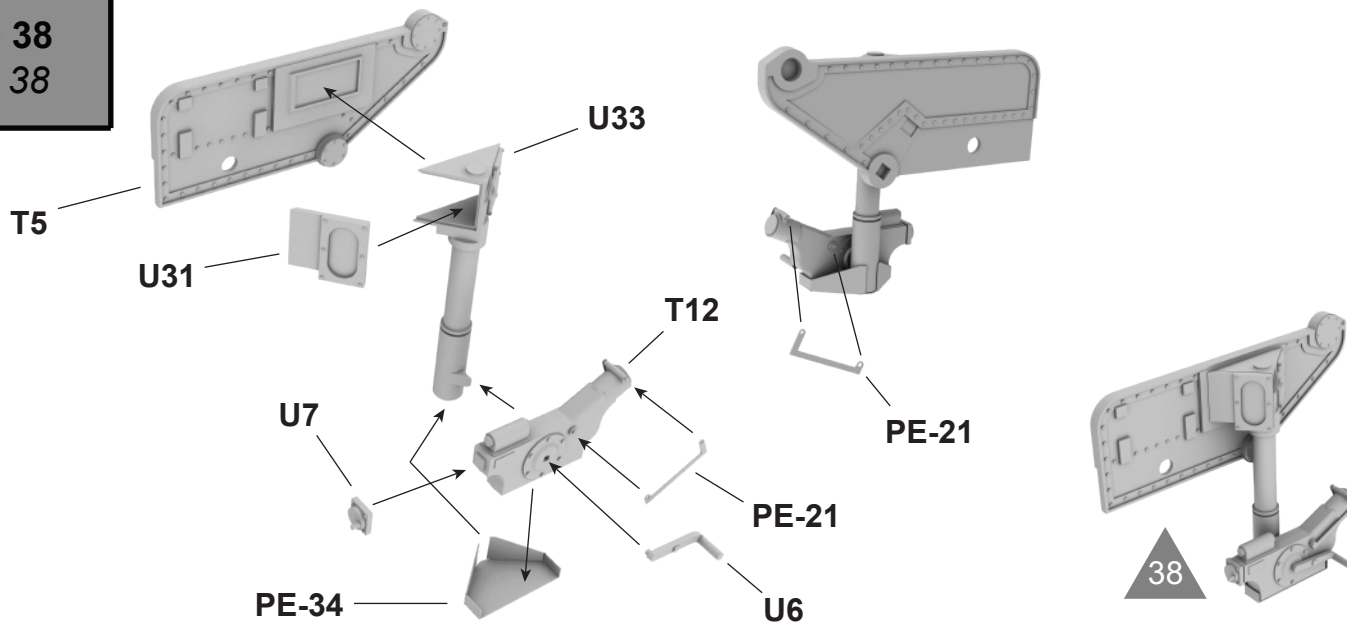

Etap 39
Step 39

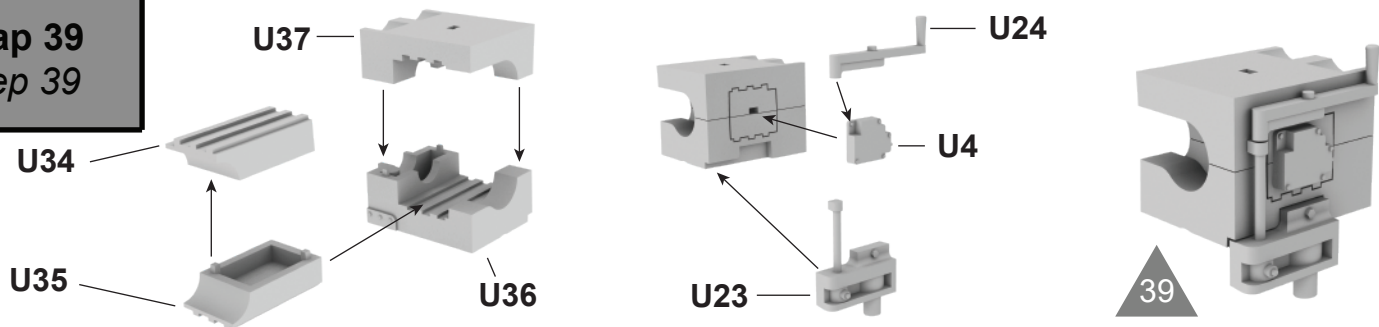

Etap 40
Step 40

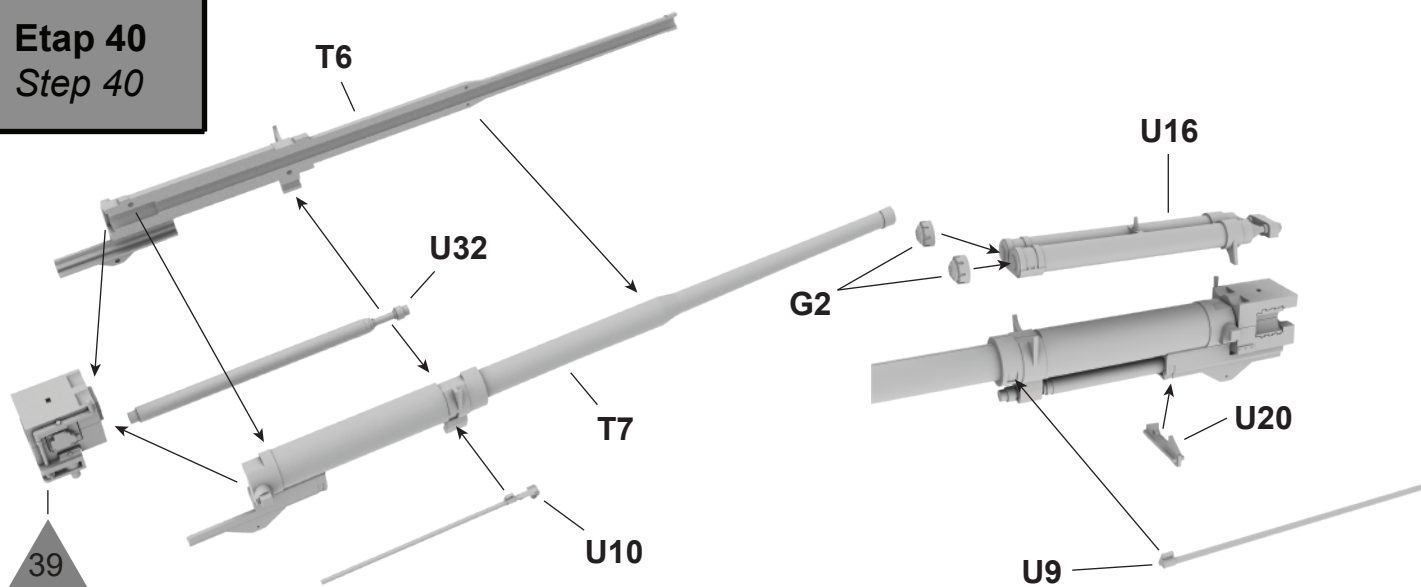

Etap 41
Step 41

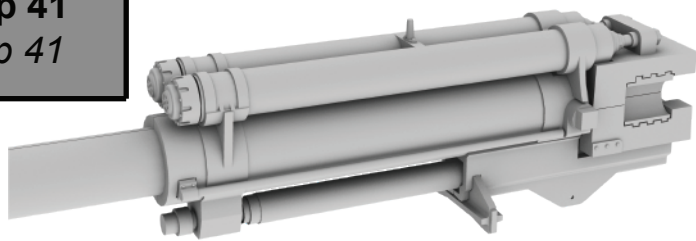

41

Nie przyklejaj elementu U8
Do not glue part U8

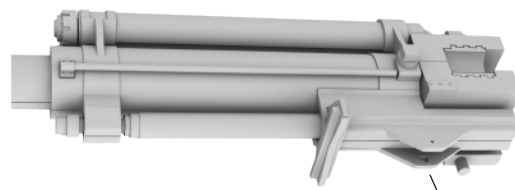

U8



Etap 42
Step 42

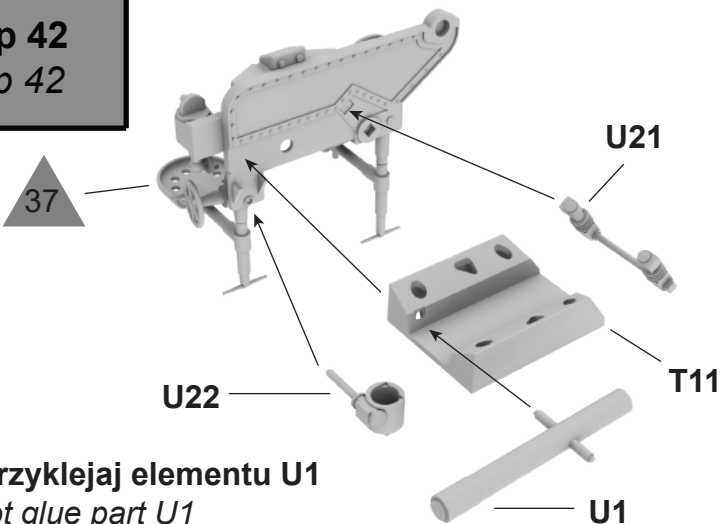

37

U21

U22

T11

U1

Nie przyklejaj elementu U1
Do not glue part U1

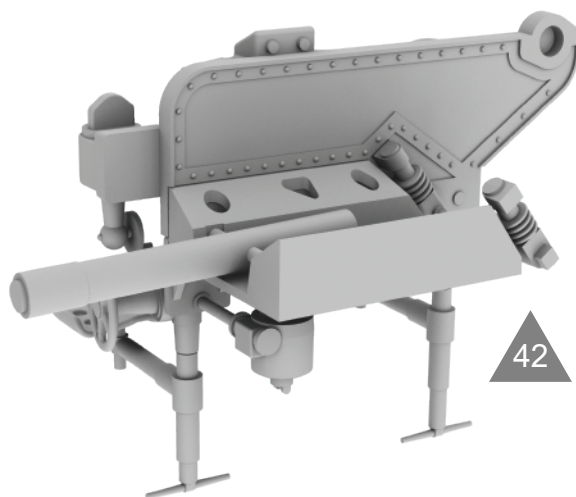

42

Etap 42
Step 42

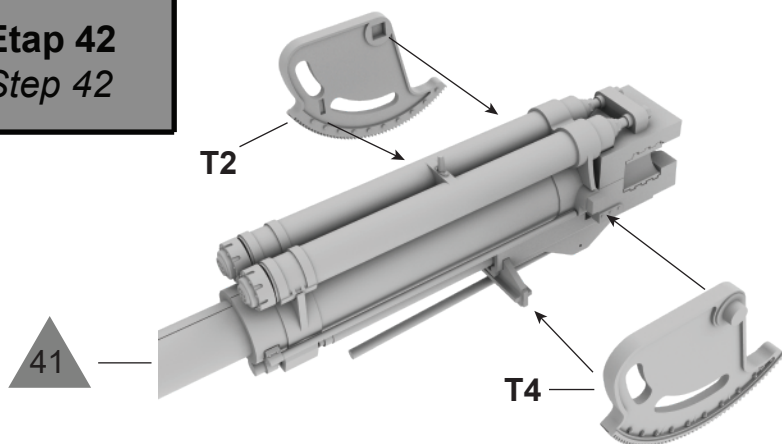

T2

T4

41

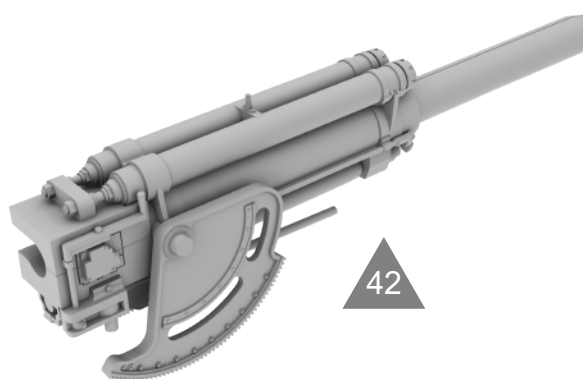

42

Etap 43
Step 43

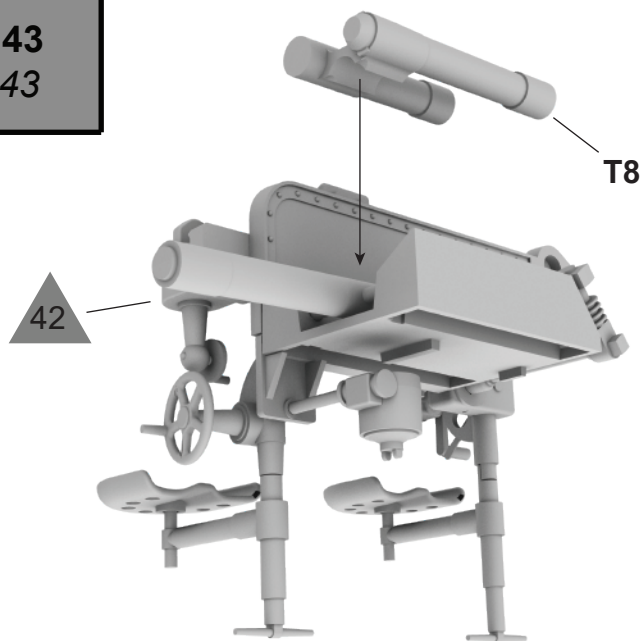

42

T8

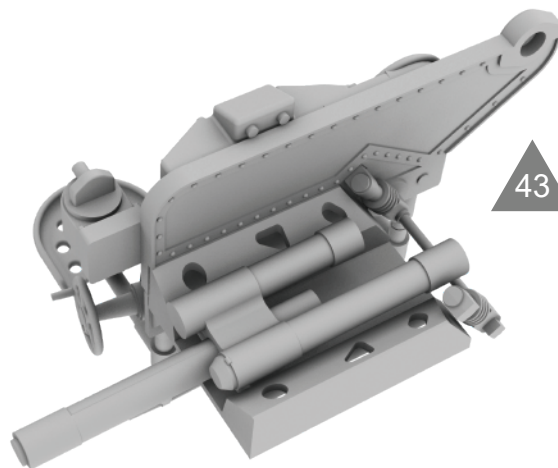

43

Etap 44
Step 44

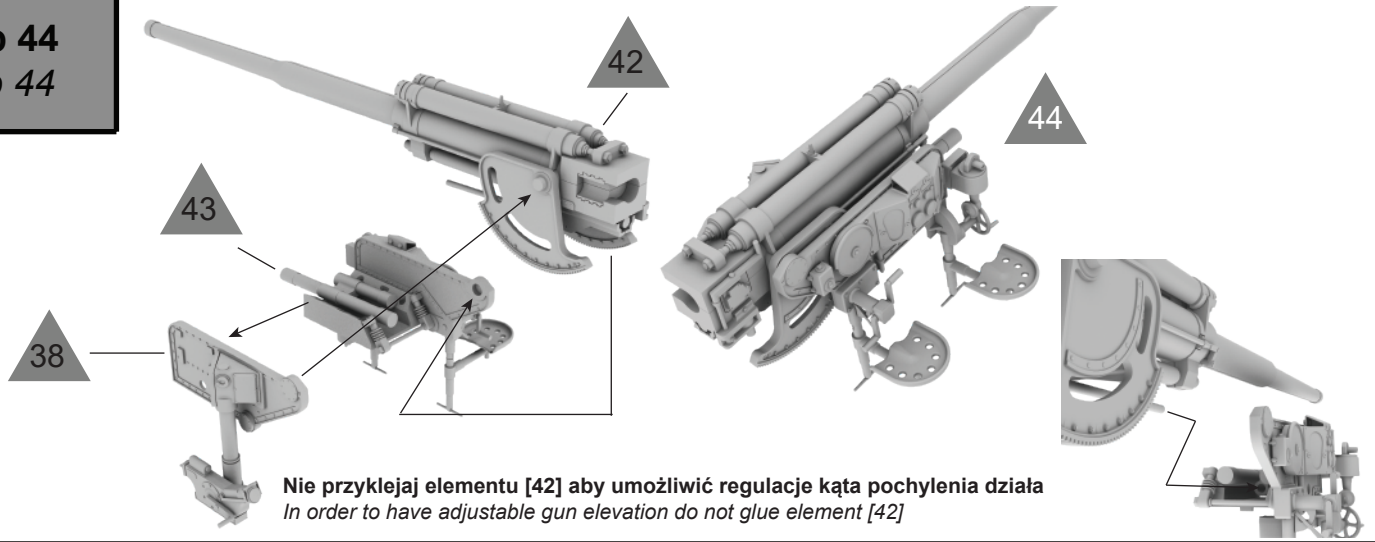

Nie przyklejaj elementu [42] aby umożliwić regulację kąta pochylenia działa
In order to have adjustable gun elevation do not glue element [42]

Etap 45
Step 45

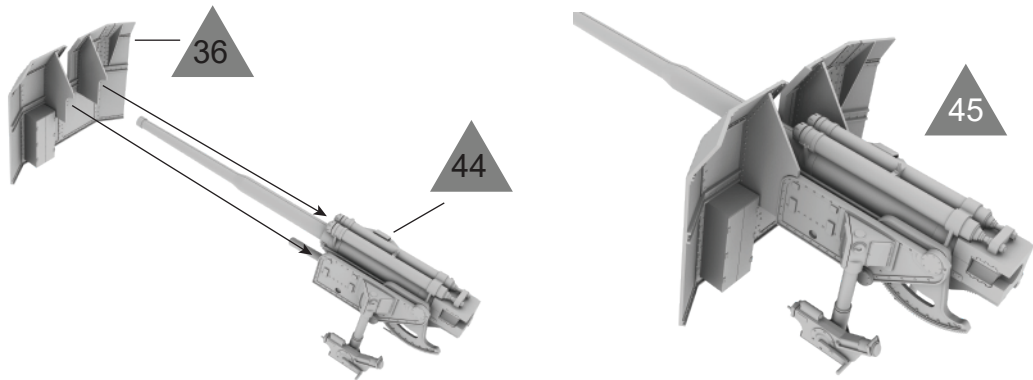

Etap 46
Step 46

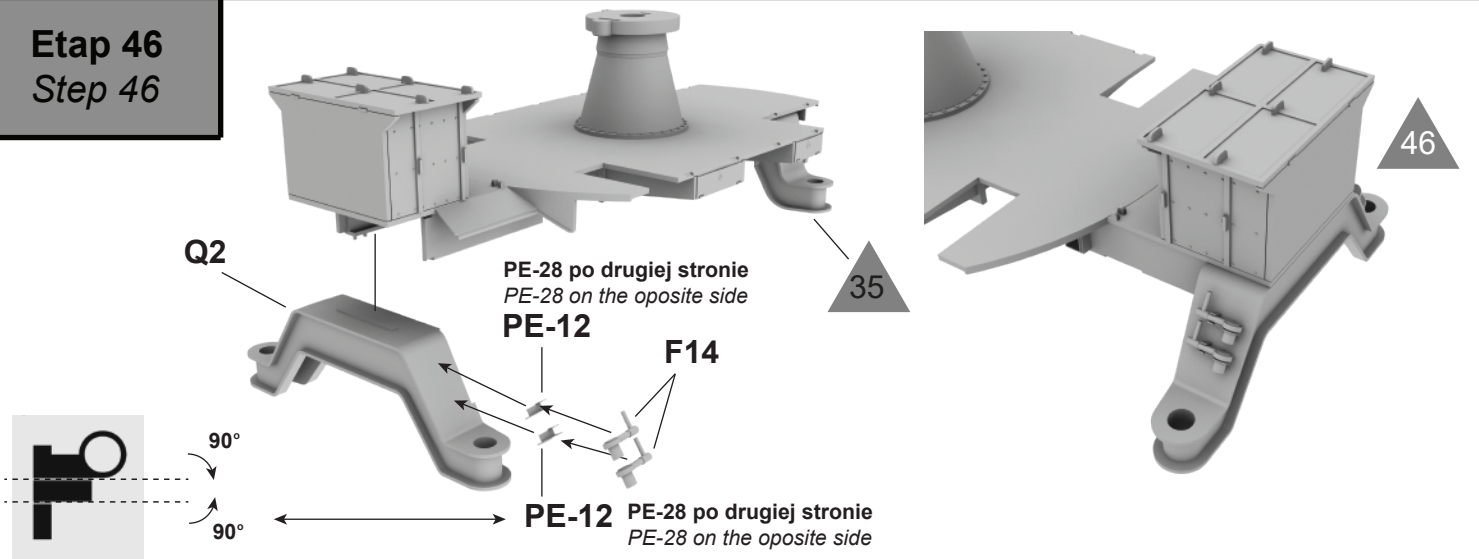

Etap 47
Step 47

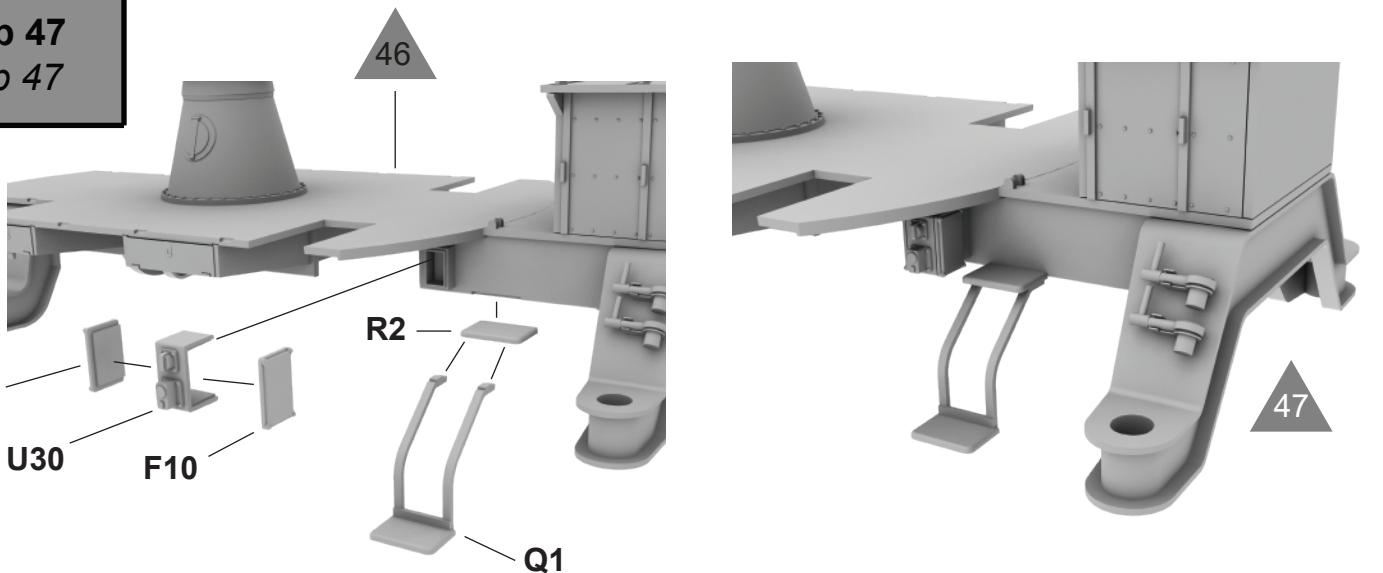

Etap 48
Step 48

Wykonaj 12
Make 12

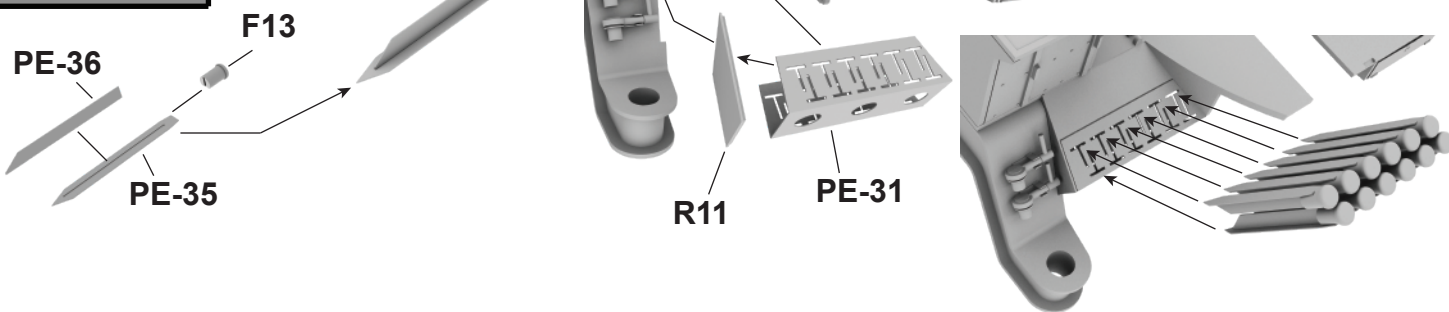

Etap 49
Step 49

Etap 50
Step 50

Wykonaj 6
Make 6

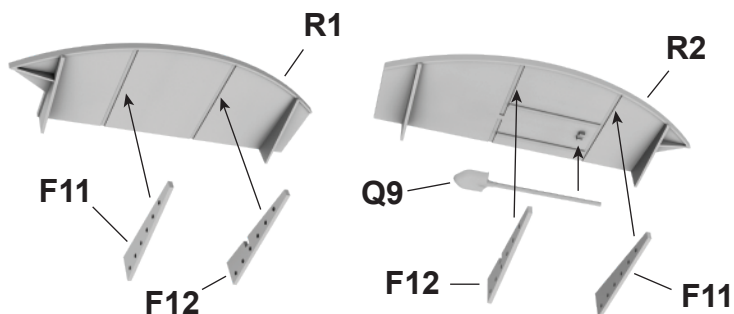
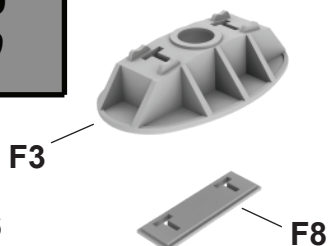

Etap 51
Step 51

48

51

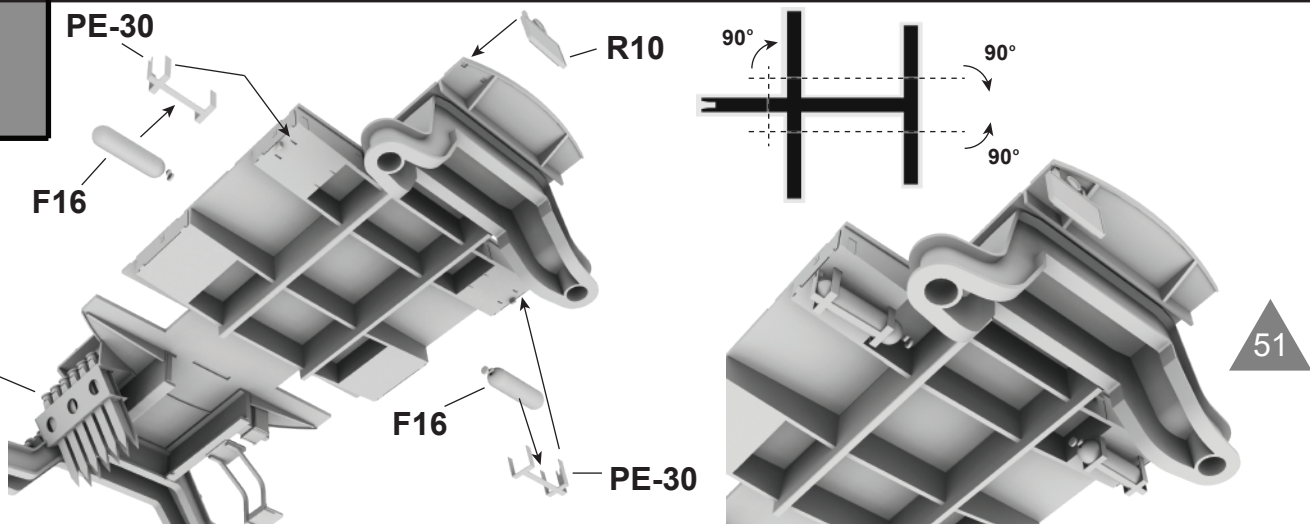

Etap 52
Step 52

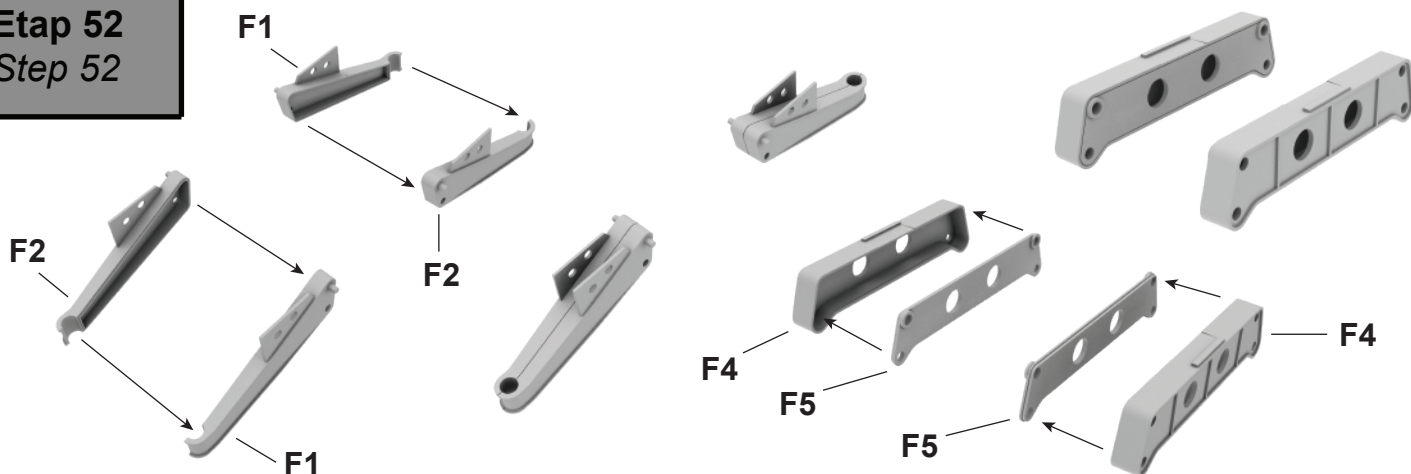

**Aby zbudować działo w pozycji bojowej wykonaj etapy 53 - 57,
a w pozycji transportowej 58 - 63.**
*To build the gun in firing position follow steps 53 - 57, and for
the transport position steps 58 - 63.*

Etap 53
Step 53

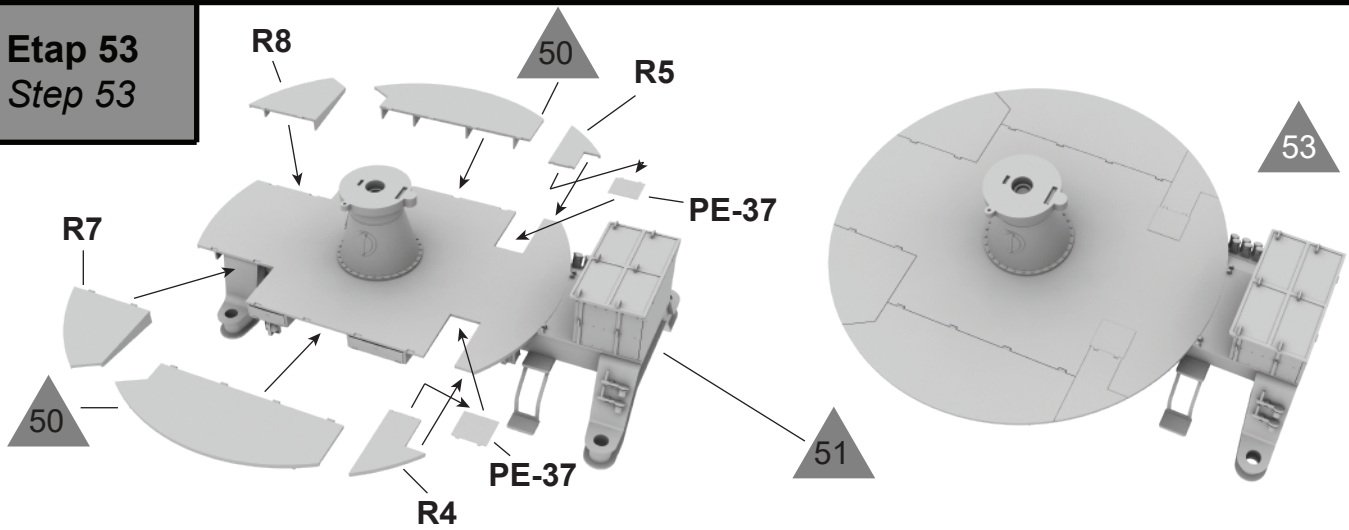

Etap 54
Step 54

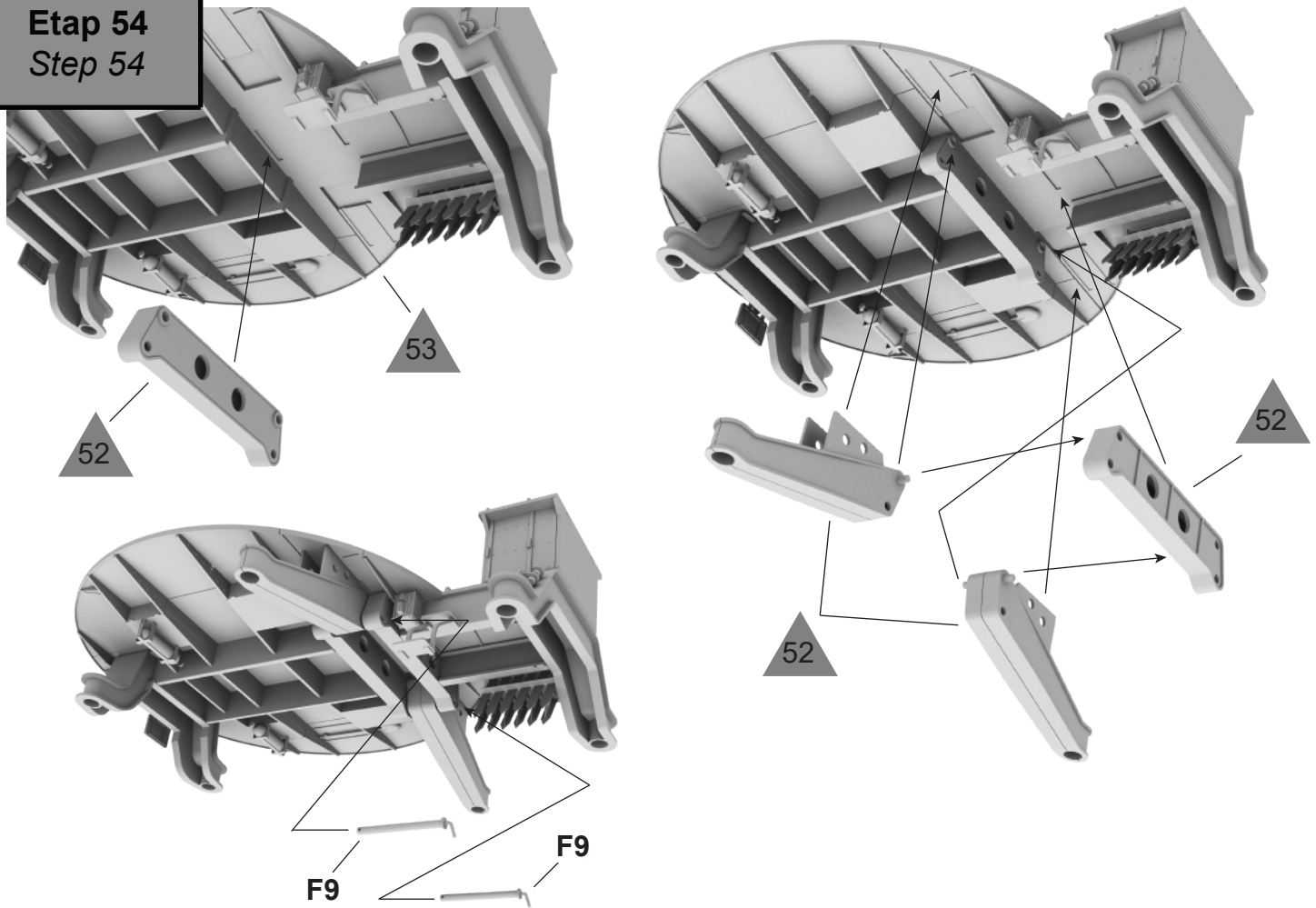

Etap 55
Step 55

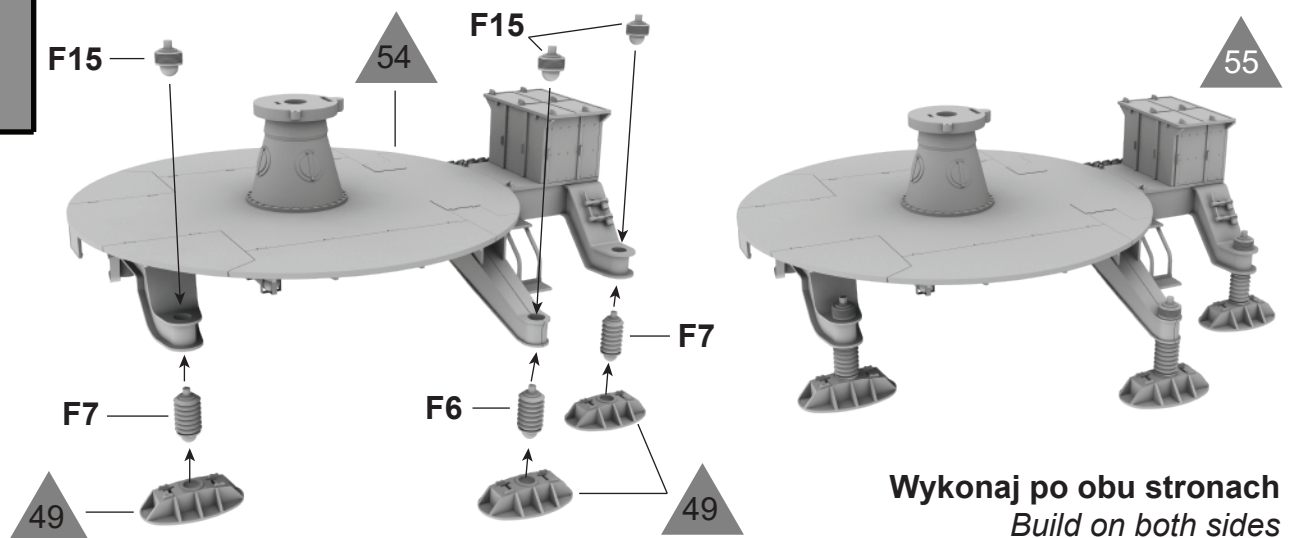

Wykonaj po obu stronach
Build on both sides

Etap 56
Step 56

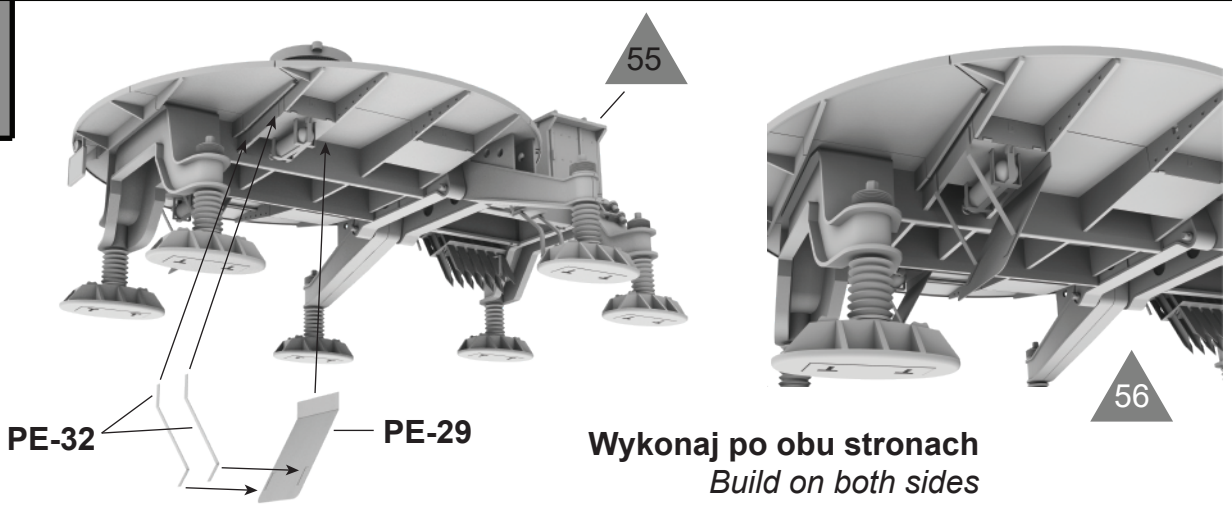
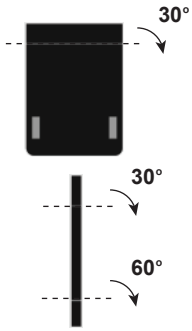

Wykonaj po obu stronach
Build on both sides

Etap 57
Step 57

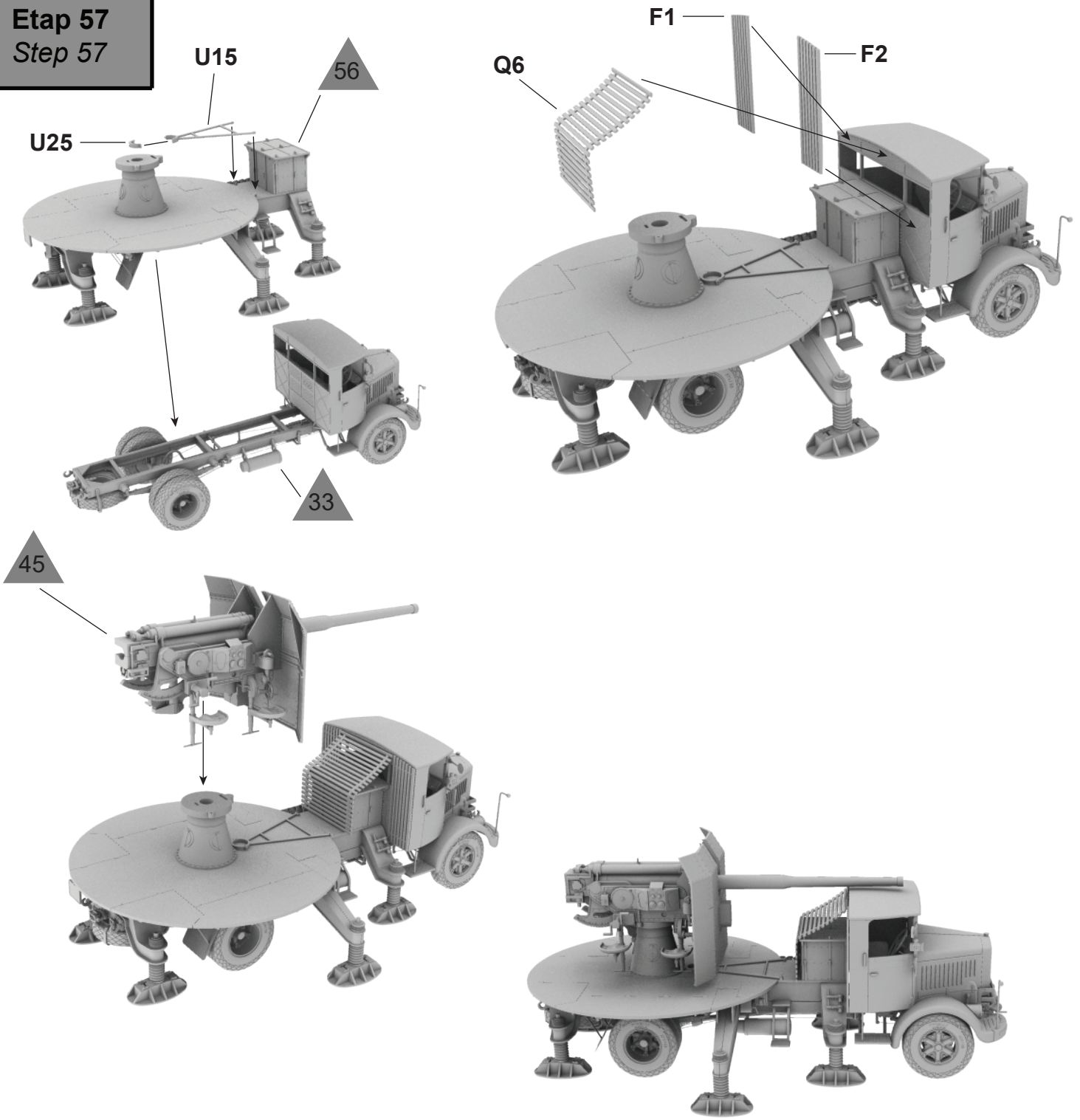

Etap 58
Step 58

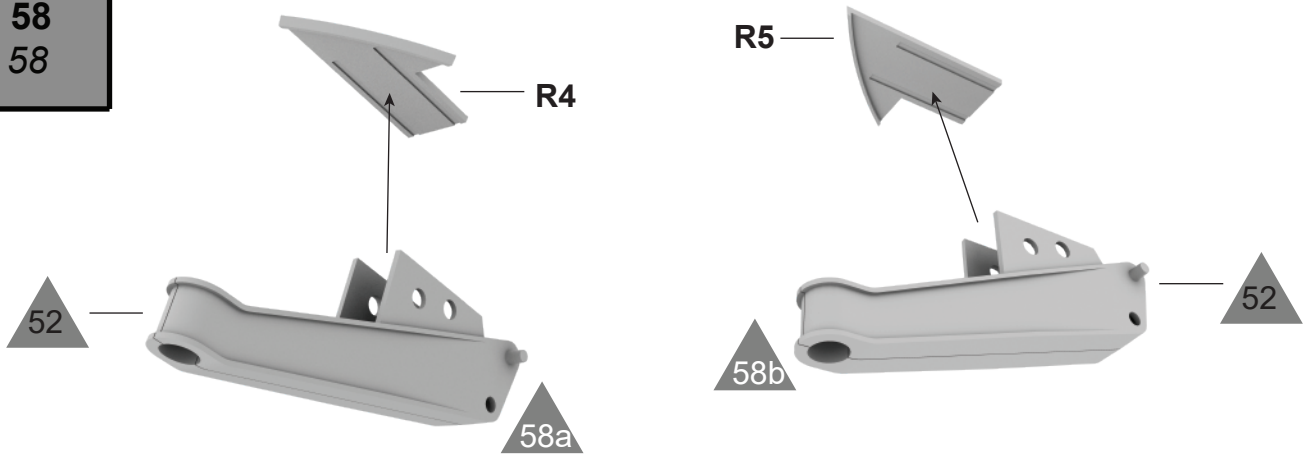

Etap 59
Step 59

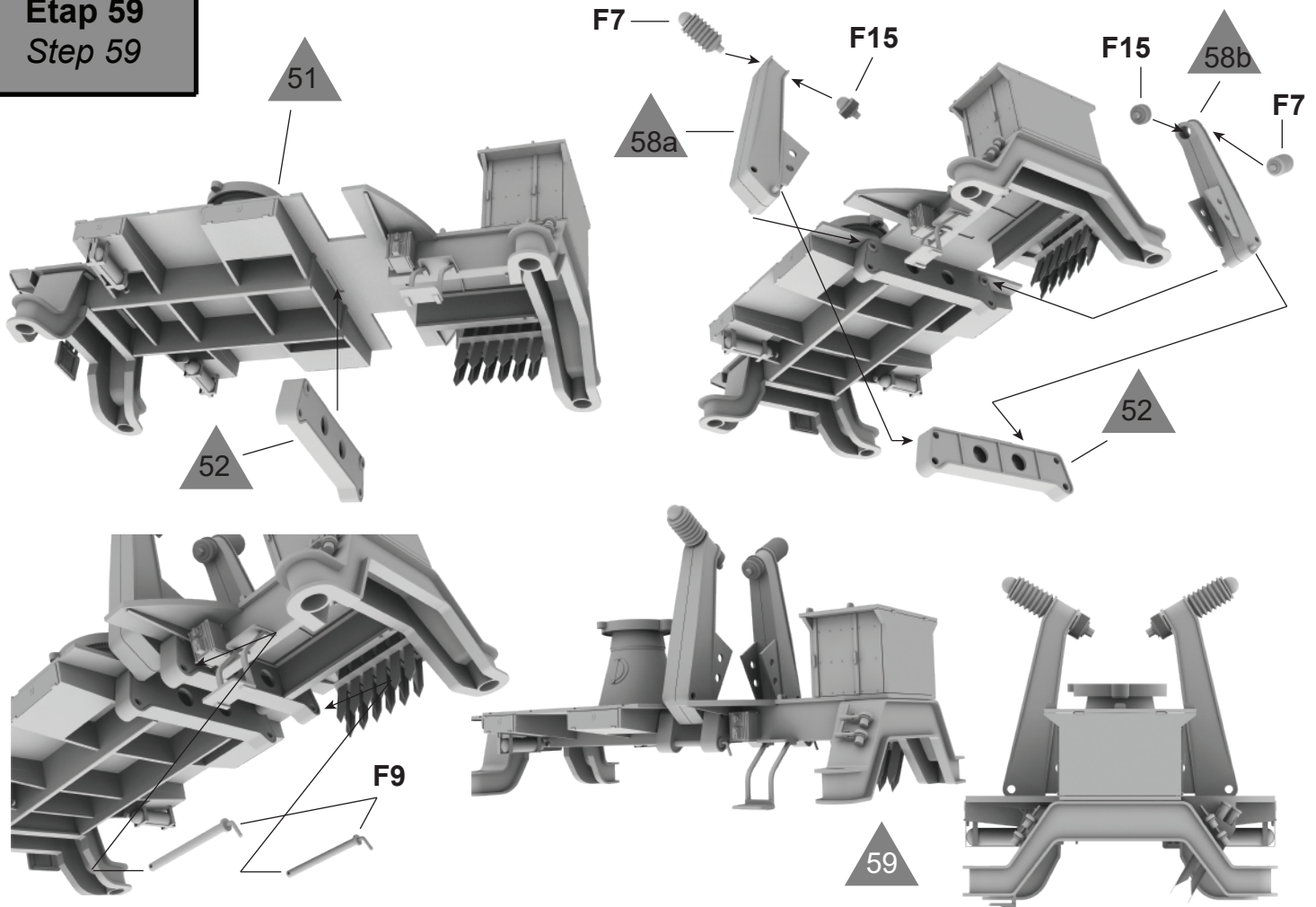

Etap 60
Step 60

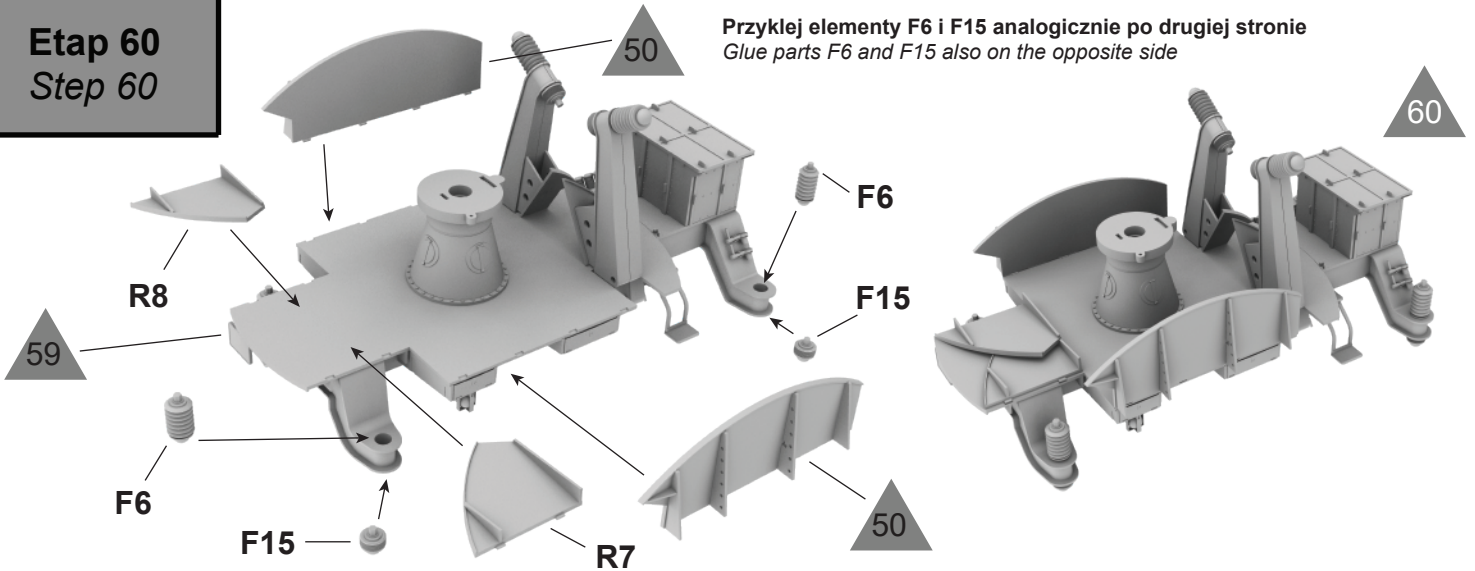

Etap 61
Step 61

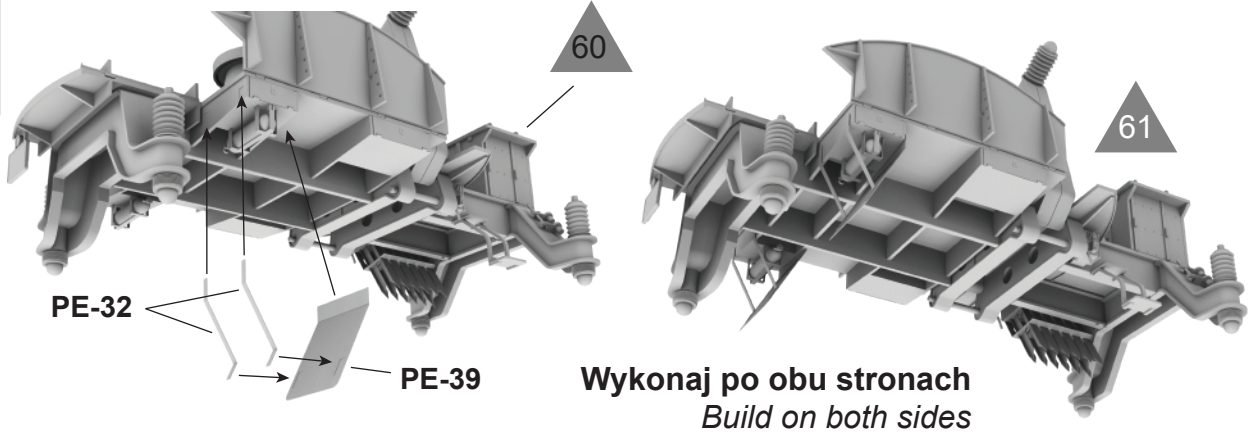
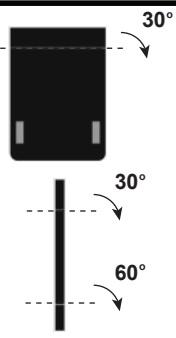

Wykonaj po obu stronach
Build on both sides

Etap 62
Step 62

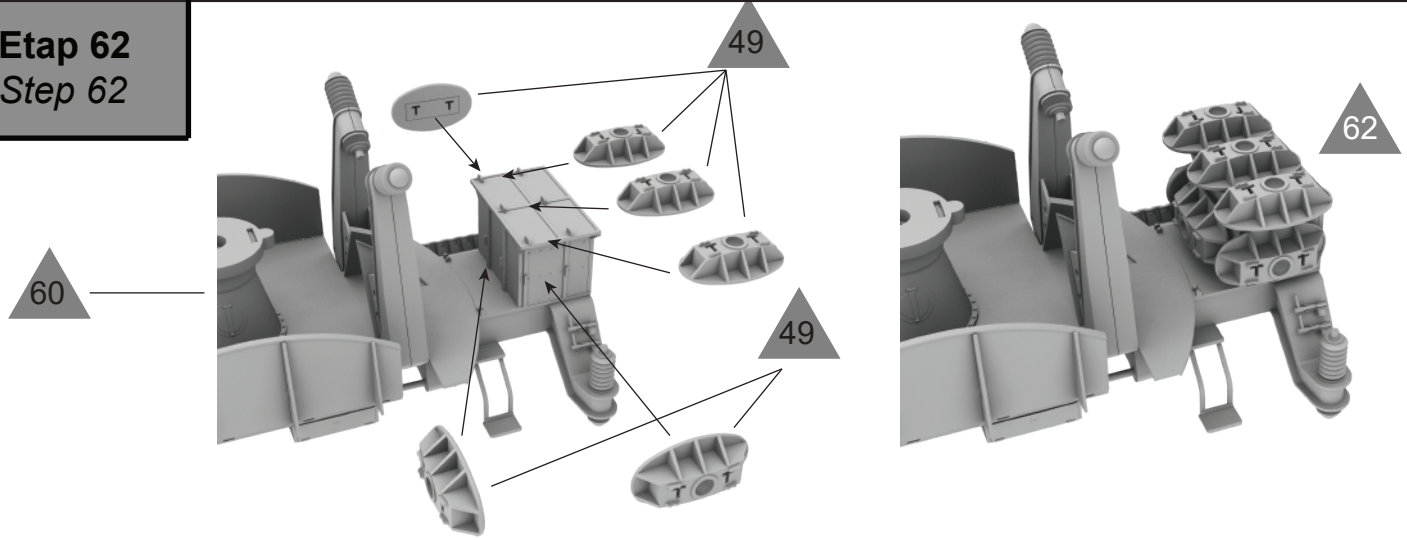

Etap 63
Step 63

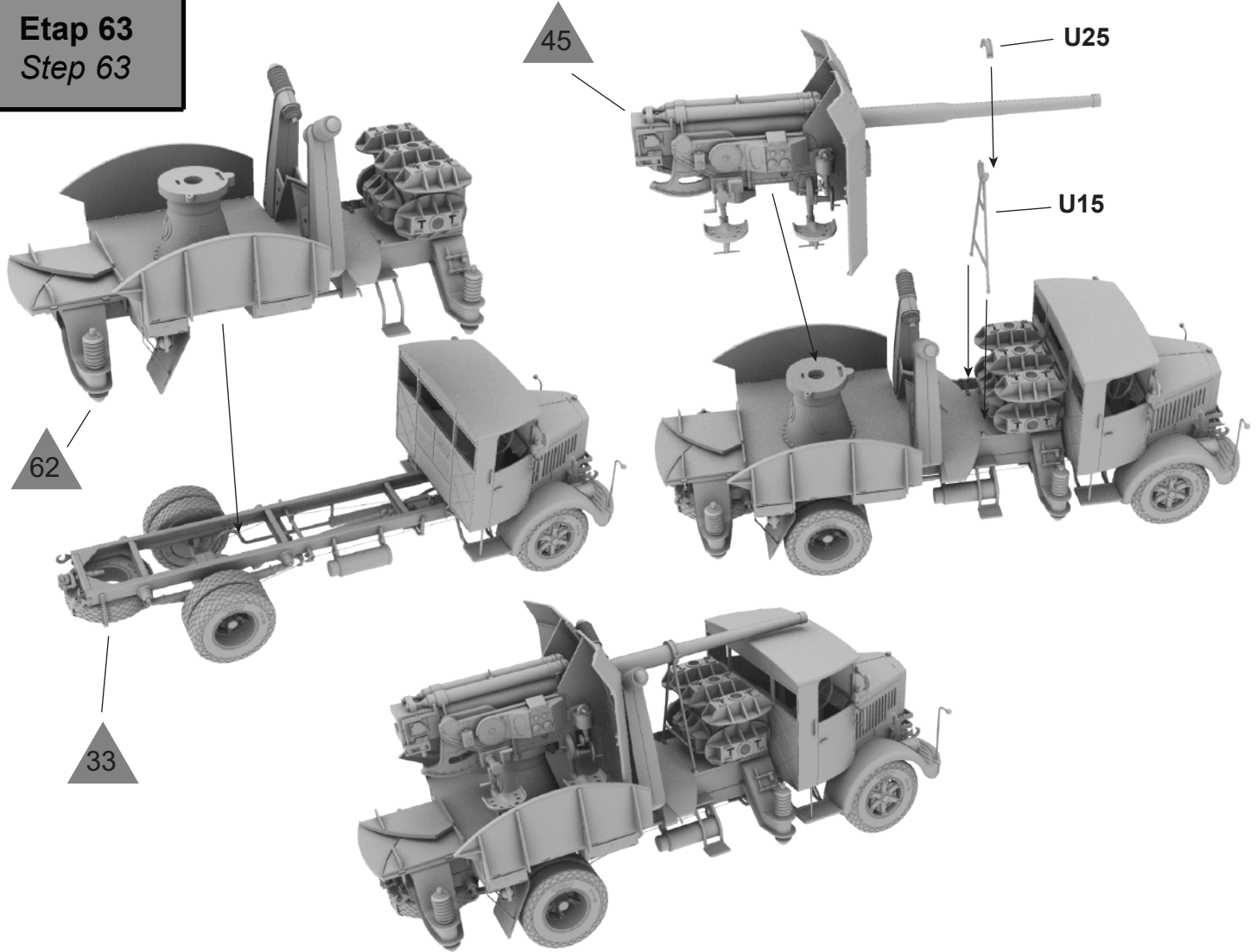

Malowanie
Painting

Italian Autocannone 3Ro 90/53 z działem 90mm, Afryka Północna 1942 r.
Italian Autocannone 3Ro 90/53 with 90/53 gun, North Africa 1942

