

1/72 Scale Plastic Model Kit

ProfiPACK
edition



item No. 70143

The MiG-21 was the most-produced supersonic fighter in the world serving with more than fifty Air Forces over four continents. The MiG-21PF was the first all-weather variant equipped with a radar.

The MiG-21 was one of a long lists of Mikoyan-Gurevich bureau designs to be integrated into the armed forces of the Soviet Union, the Warsaw Pact, and allied client states. Its predecessors included such notable types as the MiG-15, MiG-17, and the supersonic MiG-19.

The roots of MiG-21 project reach back to the first half of the fifties. In 1954, when the preliminary design study Ye-1 came to its end and was quickly replaced by the reworked Ye-2 prototype. Both had a swept wing. The first MiG design to feature the delta wing was the Ye-4 prototype, which took to the air for the first time on June 16, 1955. It was also demonstrated a year later at the Moscow airfield Tushino.

The new aircraft with the MiG-21 designation was the first successful Soviet design integrating fighter and interceptor characteristics. It was quite light Mach 2 aircraft, although the long-lasting development was adding weight gradually. The design featured sleek fuselage with the front air intake and shock cone. This feature later limited future development due to the very small space available for the radar.

The way to the interceptor

The first of the new line to enter production was the MiG-21F, which together with the MiG-21P and MiG-21F-13 represented the first generation of this line. These versions were in production through the end of the fifties and the beginning of the sixties. Simultaneously the interceptor variant design equipped with the Air-to-Air guided missiles was issued on July 24, 1958, even before the development of the first Mach 2 fighter reached the stage of serial production. The interceptor variant was to be capable to conduct the missions in all-weather/day and night conditions, which steered the development to the installation of the radar type RP-9-21 in case of aircraft from the first six production series, or RP-21, in case of aircraft from all subsequent series (starting with the 3rd aircraft from the 7th production series). The radar was installed inside the new control cone of the air inlet. All the subsequent changes necessitated increase of the length of the front fuselage in the area in front of the cockpit and, also the diameter of the front circular air trap rose from 690 mm to 870 mm. The additional avionics were placed in the space behind the cockpit, which required reduction of the volume of the front fuselage fuel tank from 235 l to 60 l only starting from the aircraft with serial No. 76210501. To countereffect this fuel volume decrease, the No. 7 tank was installed in the widened ridge superstructure extending from the canopy backwards. Also the volume of the front pair of wing integral tanks was increased. The total fuel volume was 2,680 l (210 l more compared to the F-13 variant). The 30-mm cannon of the F-13 variant was deleted, as the PF and PFM variants were relying on the missiles only. There were also many more of smaller

changes in comparison to the F-13 variant. Subsequent versions included the FL, PFM and R with production of these peaking at the end of the sixties.

The end of the long way

The third generation started production in 1968 and included the most advanced versions of MiG-21 like the M, SM, MF, SMT or Bis, among others. Simultaneously, two-seat training versions were also produced designated MiG-21U, UM and US.

Production of the MiG-21 ended in 1985. The aircraft came off the Soviet production lines in Moscow, Gorky and Tbilisi, while the MiG-21F-13 was also built under license in Czechoslovakia and the MiG-21FL, M and bis in India by Hindustan Aeronautics Ltd. The Soviet Union produced 10,645 examples of all versions, 194 were built in Czechoslovakia and 657 in India. That counts 11,496 aircraft produced.

During the Cold War, the opponents of the MiG-21 included aircraft like the Northrop F-5 Freedom Fighter, the Dassault Mirage III and similar ones. NATO assigned it the reporting name "Fishbed", while the Soviet pilots called it "Balalaika" due to the shape resemblance with the popular Russian musical instrument.

The kit: MiG-21PF

This plastic model kit represents the MiG-21PF, identified as the "Izdelye 76" (Series 76) in factory documentation. It was the basic mass-produced modification of the MiG-21PF and the plant No. 21 at Nizhny Novgorod was building them primarily for the Soviet Air Force. Between 1961 and 1965, a total of 525 of MiG-21PFs were produced there. The export version was marked as "Izdelye 76A" and differed only in the installation of another type of „Friend-Foe“ identification system. The export examples were produced by plant No. 30 in Moscow and was widely used by the member states of the Warsaw Pact. Some of the MiG-21PFs delivered to the GDR (German Democratic Republic), received a modified radar with mode for searching and tracking ground targets.

The most successful era of the PF variant is marked by the Vietnam War combat use. The Vietnamese got their first MiG-21PFLs at the end of 1965. The PFL variant was just a minor change to the standard PF, as it differed in installation of a simplified radio compass ARK-10 and more advanced KSI-2 compass instead of KSI only. Another change was absence of the radio altimeter. The MiG-21PFL was manufactured by plant No. 21 on the line dedicated to the production for Soviet Union.

The MiG-21PF was powered by a Tumanskiy R-11F2-300 engine. Hardpoints could be loaded with RS-3US, R-3S missiles, also the UB-16-57 rocket pods, S-24 unguided rockets and bombs up to 500 kg calibre could be used. NATO assigned MiG-21PF and all of its sub-variations the codename „Fishbed D“.



Carefully read instruction sheet before assembling. When you use glue or paint, do not use near open flame and use in well ventilated room. Keep out of reach of small children. Children must not be allowed to suck any part, or pull vinyl bag over the head.



Před započatím stavby si pečlivě prostudujte stavební návod. Při používání barev a lepidel pracujte v dobře větrané místnosti. Lepidla ani barvy nepoužívejte v blízkosti otevřeného ohně. Model není určen malým dětem, mohlo by dojít k požití drobných dílů.

INSTRUCTION SIGNS * INSTR. SYMBOLS * INSTRUKTION SINNBILDEN * SYMBOLES * 記号の説明

OPTIONAL
VOLBABEND
OHNOUTSAND
BROUSITOPEN HOLE
VYVRTAT OTVORSYMETRICAL ASSEMBLY
SYMETRICKÁ MONTÁŽREMOVE
ODRÍZNOUTREVERSE SIDE
OTOČITAPPLY EDUARD MASK
AND PAINT
POUŽÍT EDUARD MASK
NABARVIT

PARTS



DÍLY



TEILE



PIÈCES



部品

PLASTIC PARTS

C>

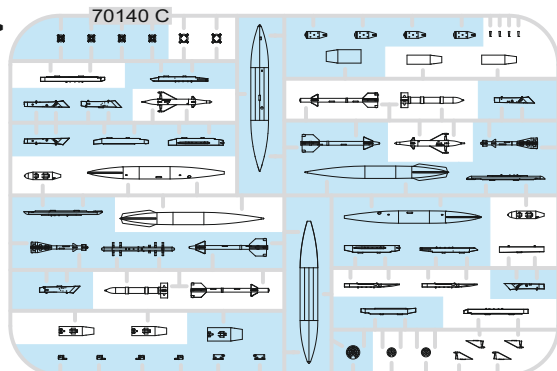

D>

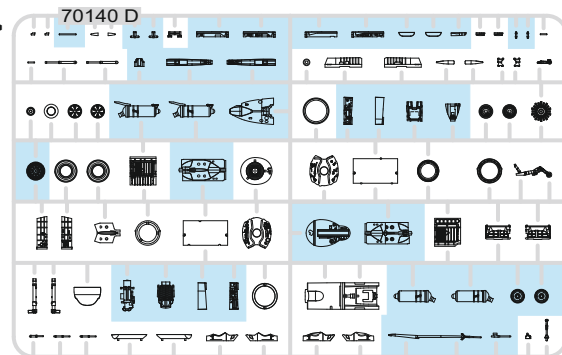

G>

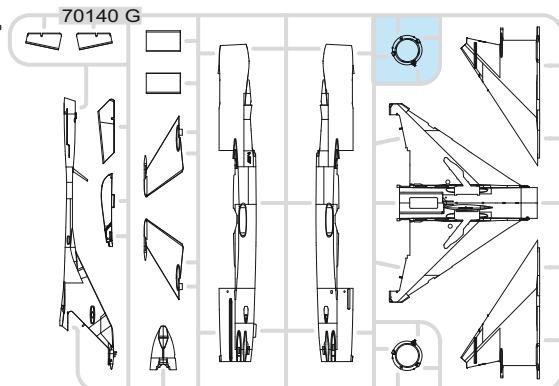

H>

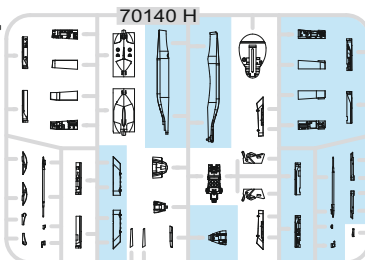

I>

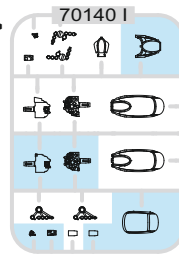
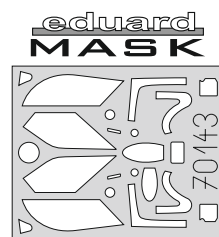
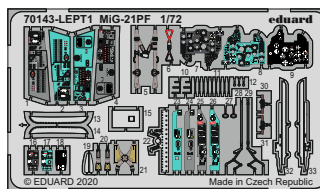
PE - PHOTO ETCHED
DETAIL PARTS

-Parts not for use. -Teile werden nicht verwendet. -Pièces à ne pas utiliser. -Tyto díly nepoužívejte při stavbě. - 使用しない部品

COLOURS



BARVY



FARBEN



PEINTURE



色

GSI Creos (GUNZE)		MISSION MODELS	
AQUEOUS	Mr.COLOR	PAINTS	
H1	C1	[MMP-001]	WHITE
H3	C3	[MMP-003]	RED
H4	C4	[MMP-007]	YELLOW
H5	C5	[MMP-048]	BLUE
H11	C62	[MMP-001]	FLAT WHITE
H12	C33	[MMP-047]	FLAT BLACK
H26	C66		BRIGHT GREEN
H51	C11	[MMP-063]	LIGHT GULL GRAY
H70	C60	[MMP-056]	GRAY
H72	C369	[MMP-078]	DARK EARTH
H77	C137	[MMP-040]	TIRE BLACK
H81	C55	[MMP-023]	KHAKI
H84	C42		MAHOGANY
H90	C47		CLEAR RED
H94	C138		CLEAR GREEN
H302	C302		GREEN

GSI Creos (GUNZE)		MISSION MODELS	
AQUEOUS	Mr.COLOR	PAINTS	
[H303]	C303	[MMP-066]	GREEN
[H305]	C305	[MMP-084]	GRAY
[H308]	C308		GRAY
[H310]	C310	[MMP-060]	BROWN
[H321]	C321	[MMP-086]	LIGHT BROWN
[H332]	C3332		LIGHT AIRCRAFT GRAY
[H337]	C337		GRAYISH BLUE
	C391		INTERIOR TURQUOISE GREEN
	C392		INTERIOR BLUE
Mr.METAL COLOR		METALLICS	
	[MC213]	[MMM-006]	STEEL
	[MC214]	[MMM-001]	DARK IRON
	[MC218]	[MMM-003]	ALUMINIUM
Mr.COLOR SUPER METALLIC		METALLICS	
	[SM201]	[MMC-001]	SUPER FINE SILVER

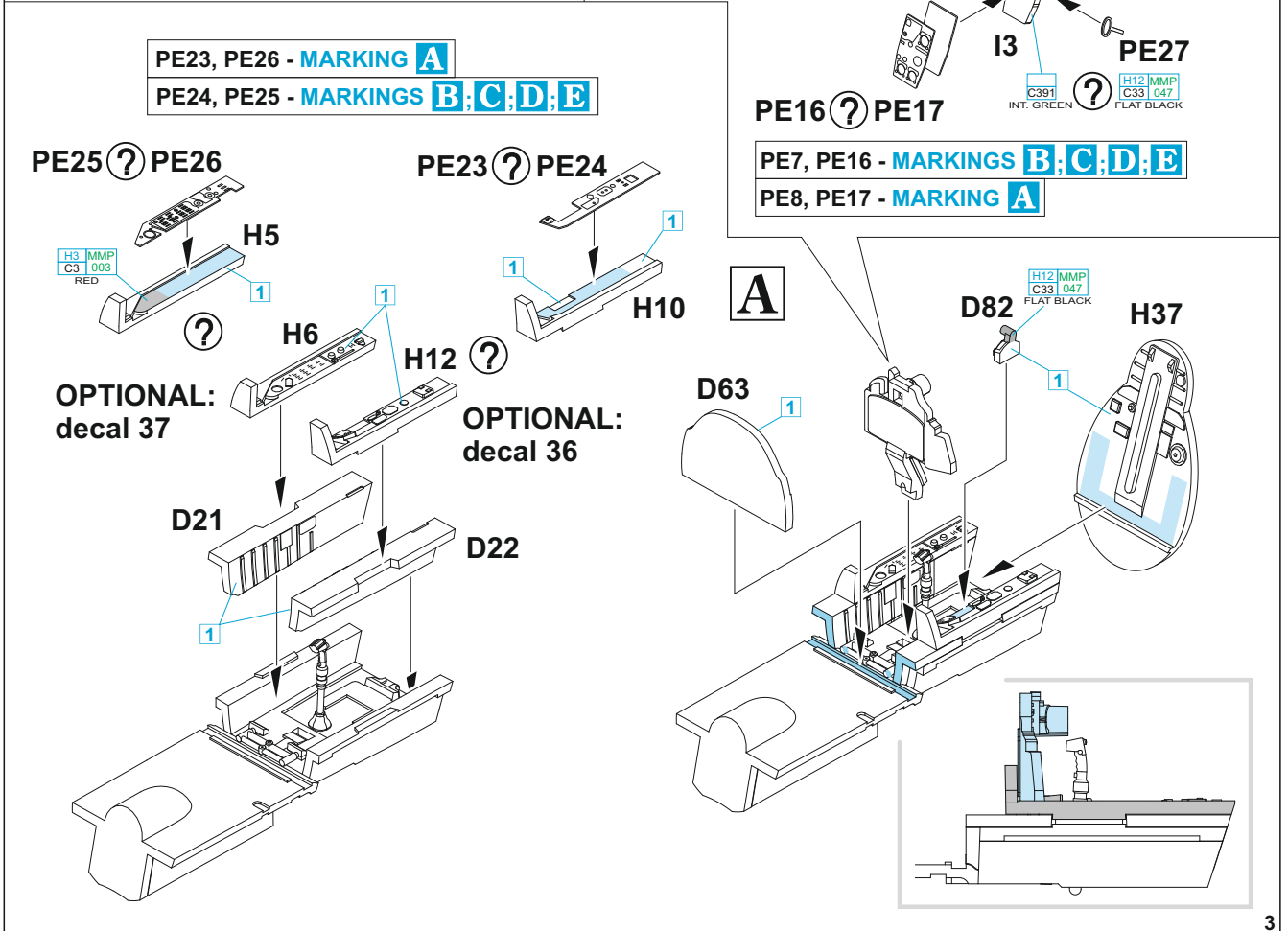
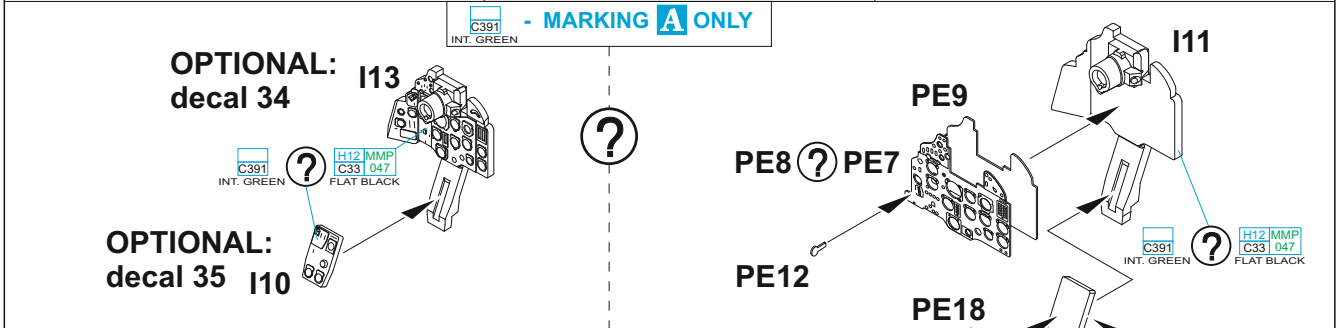
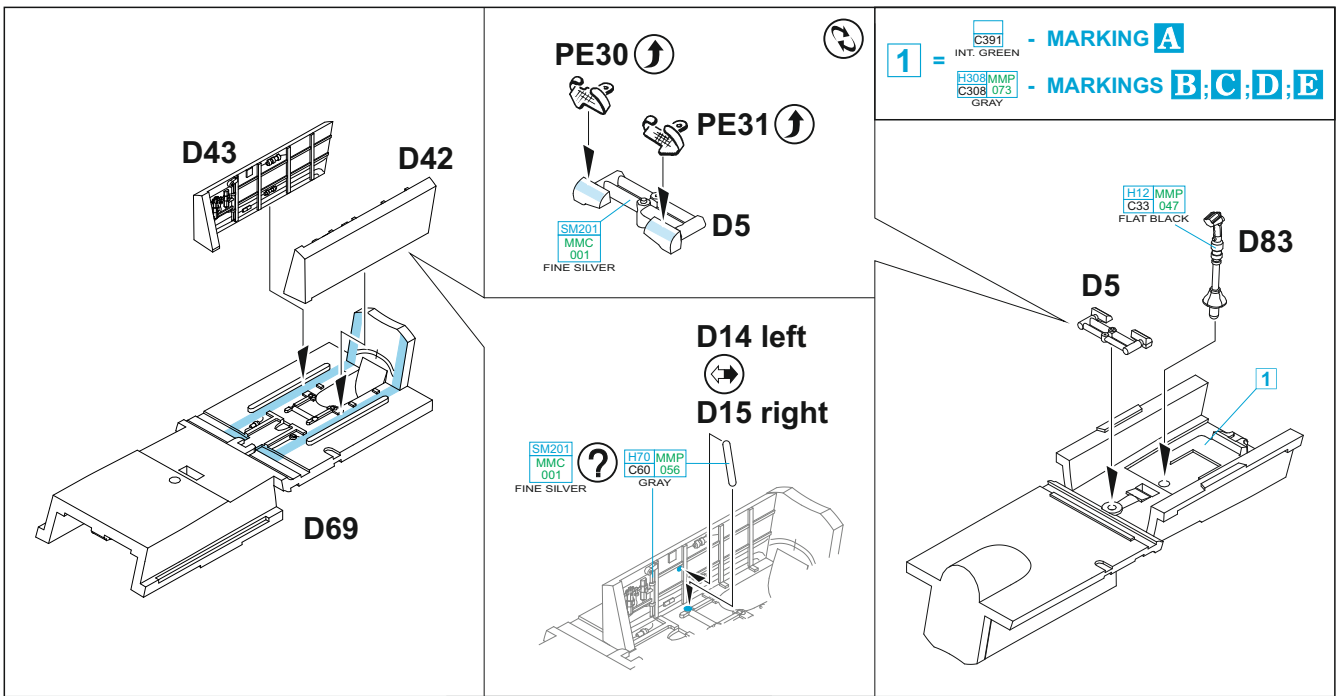

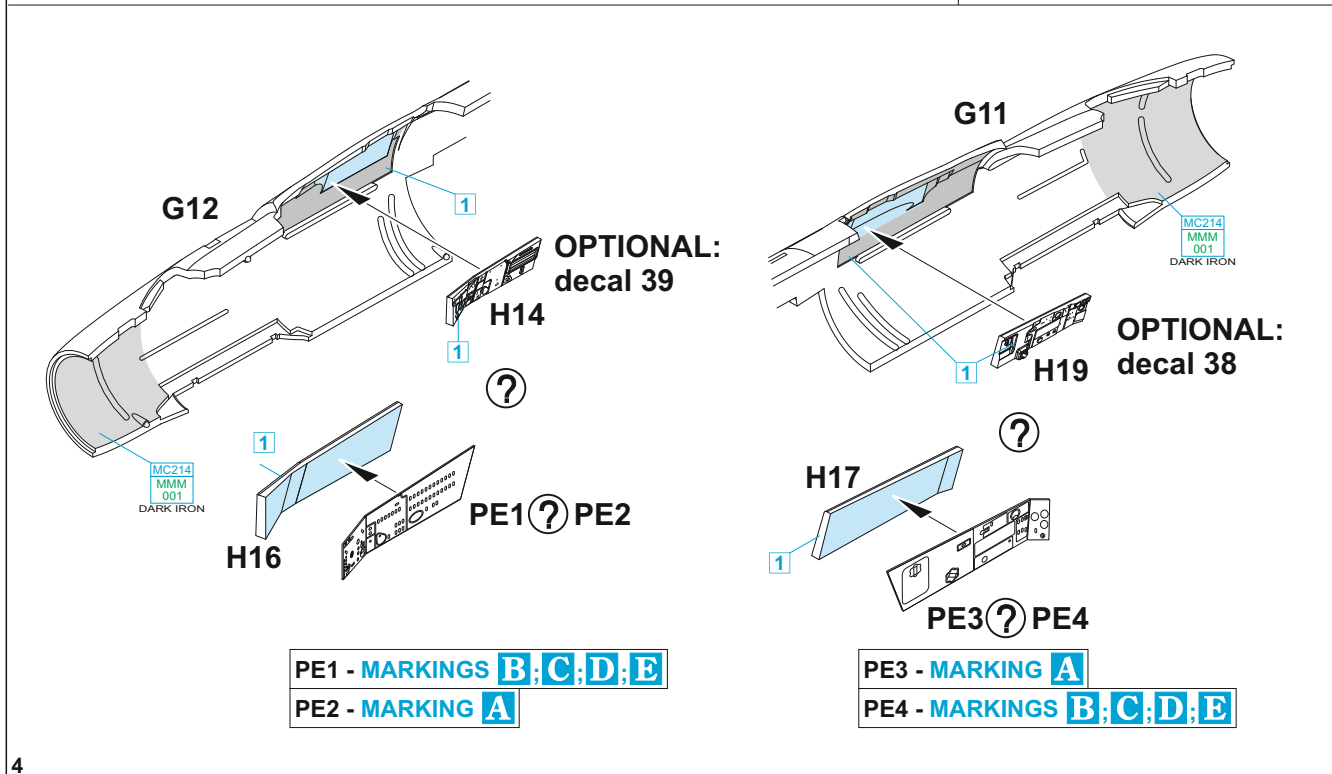
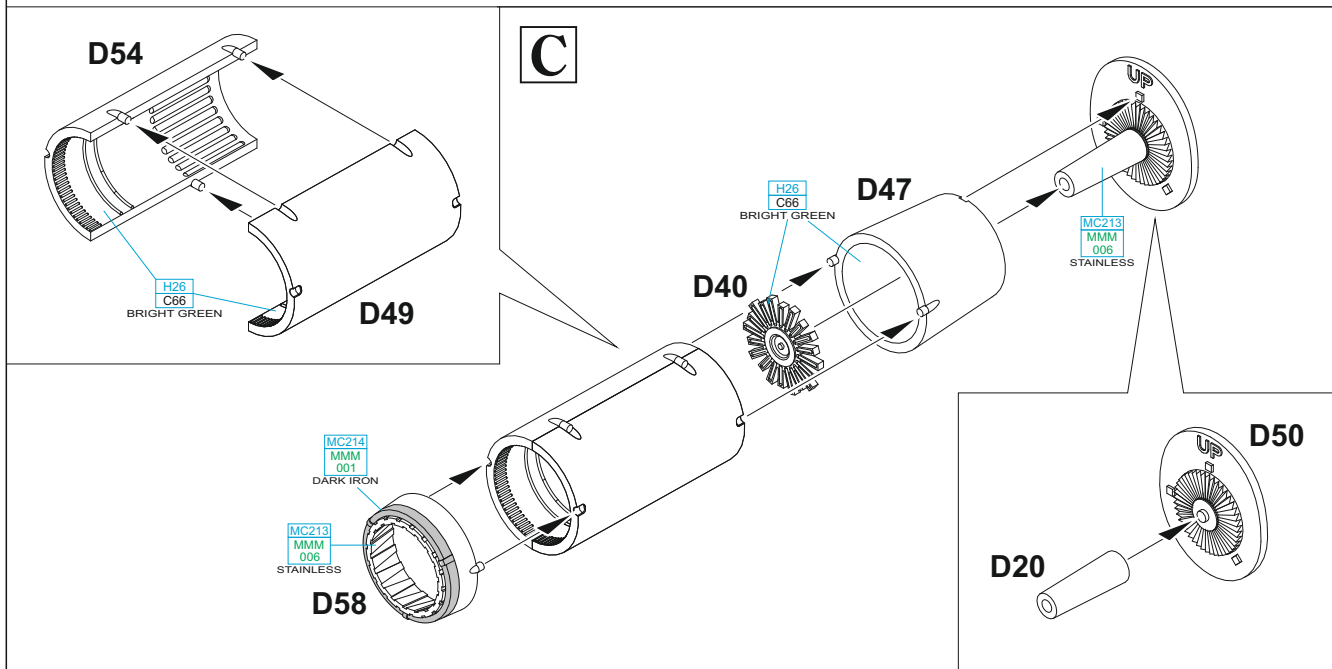
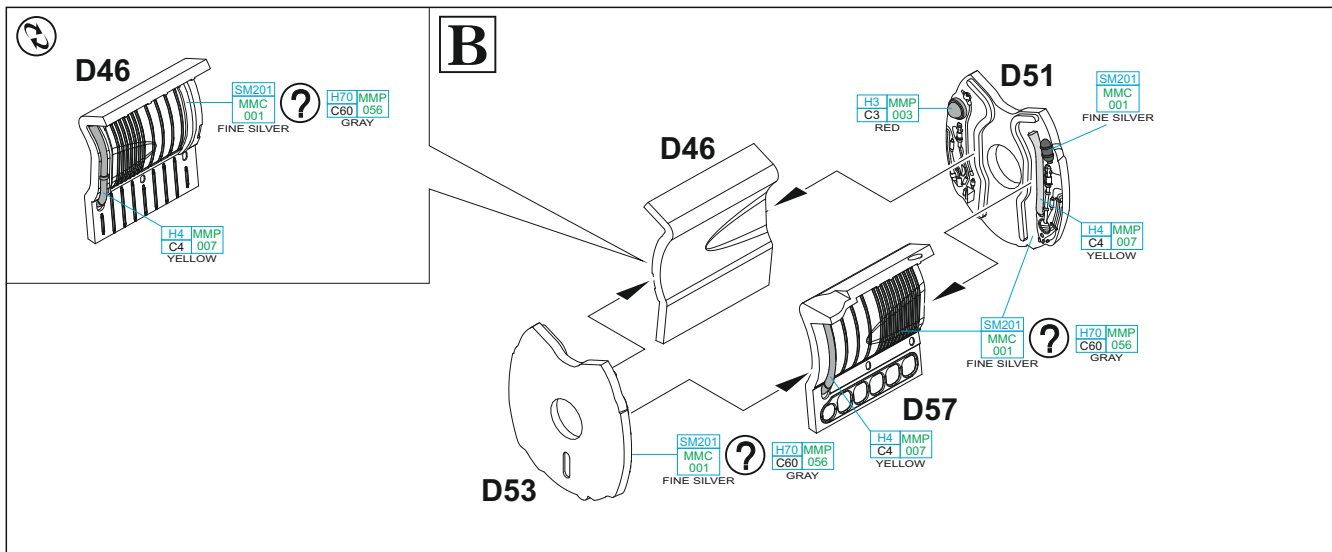

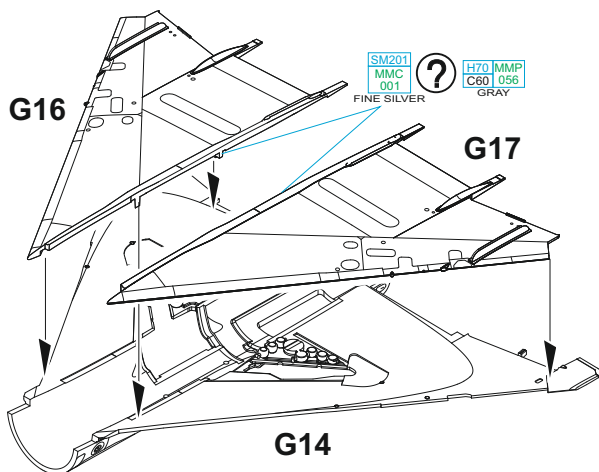
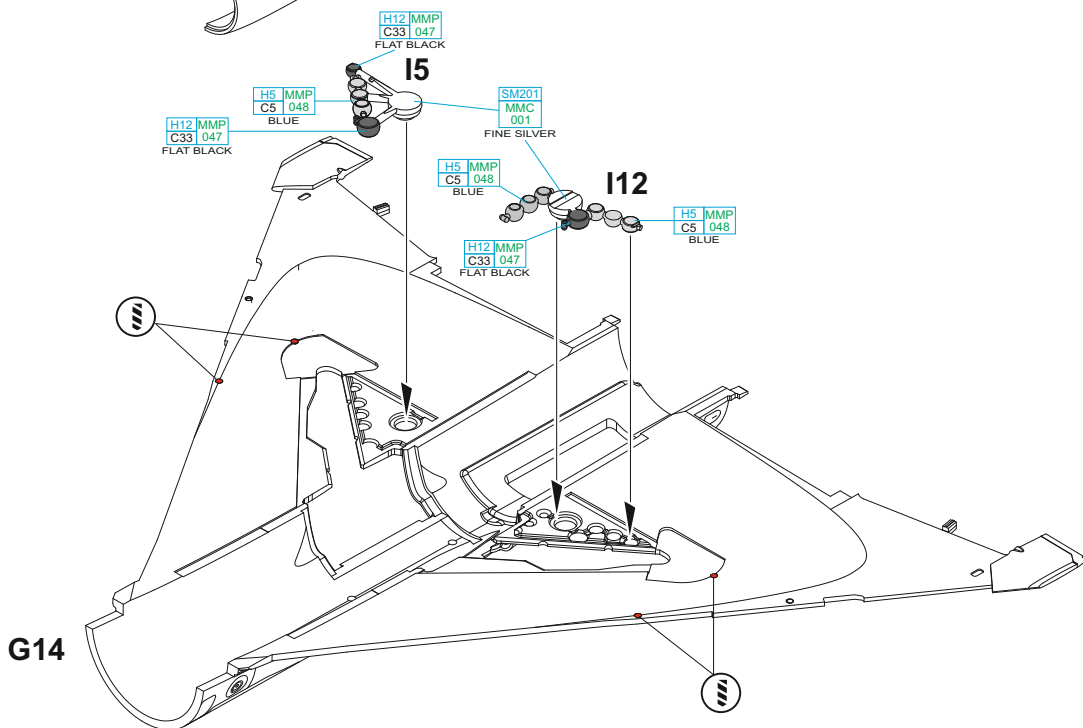
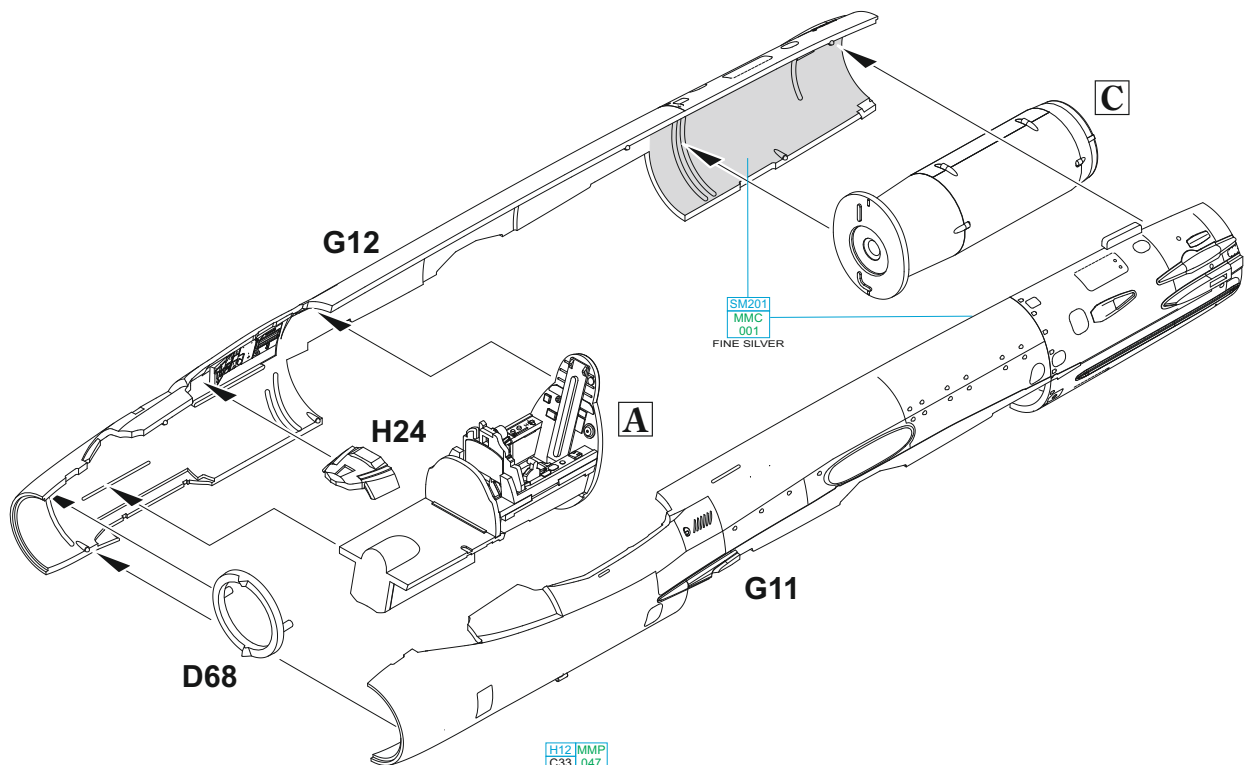

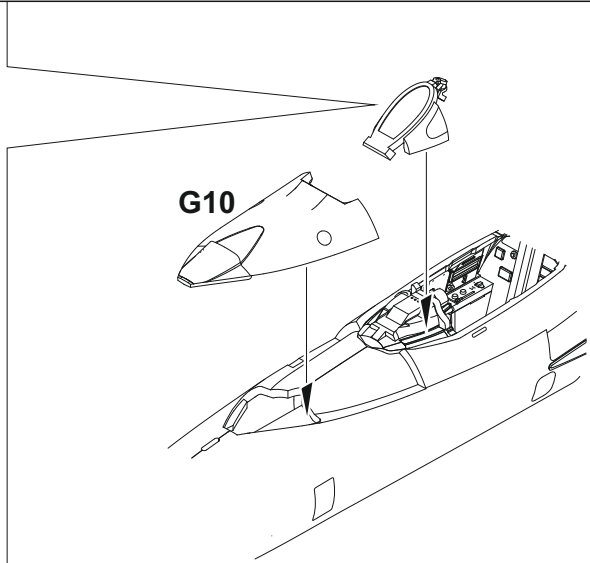
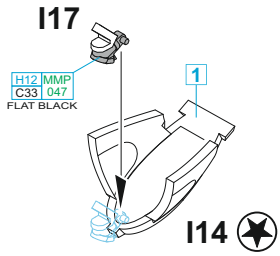
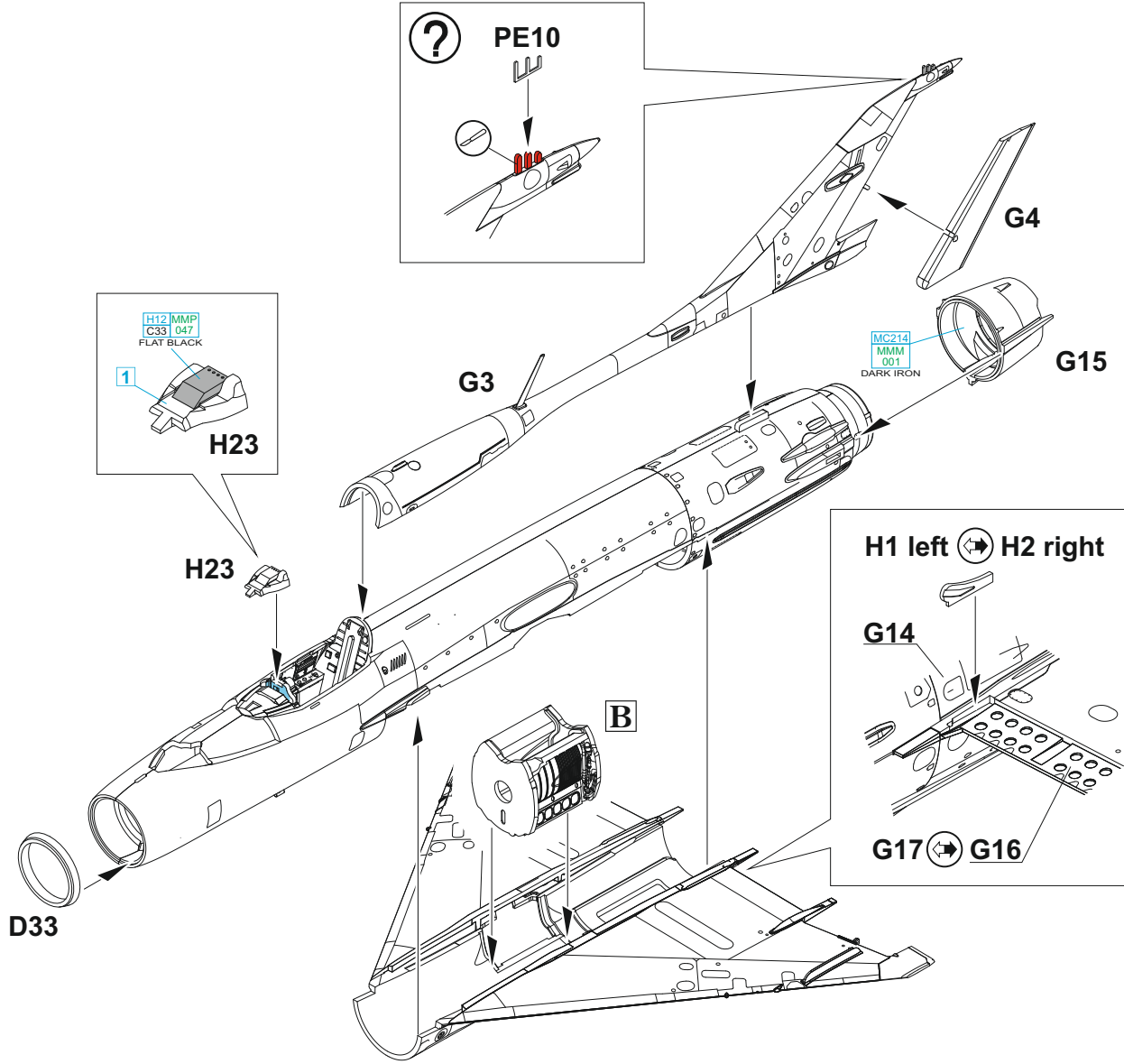
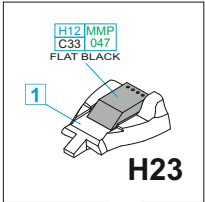
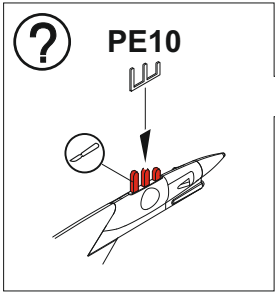

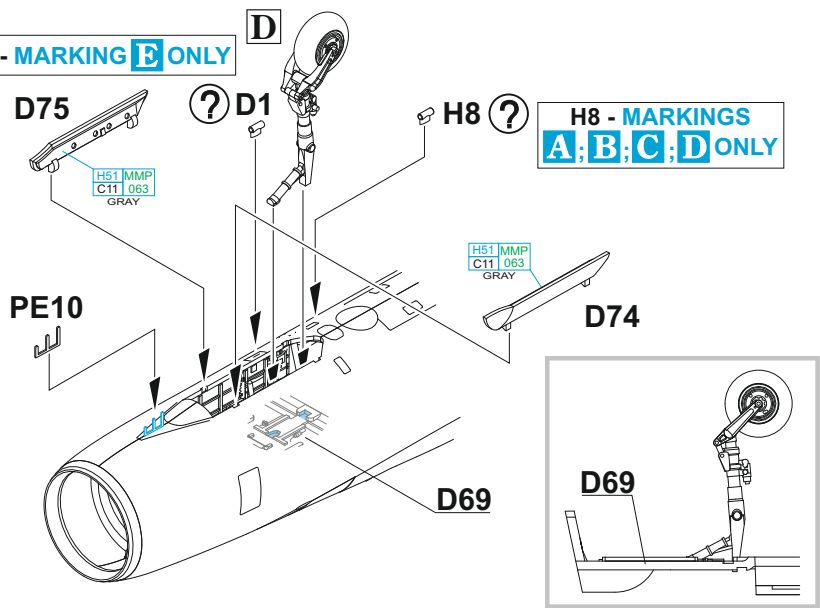
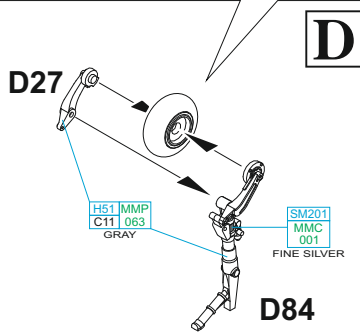
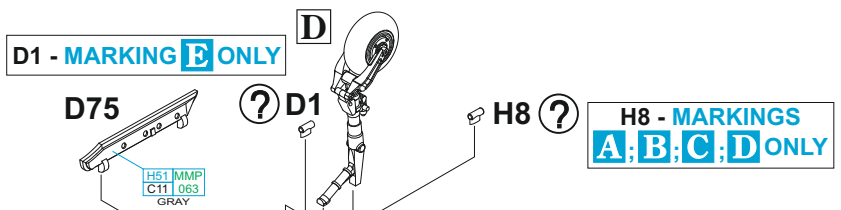
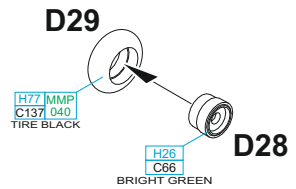
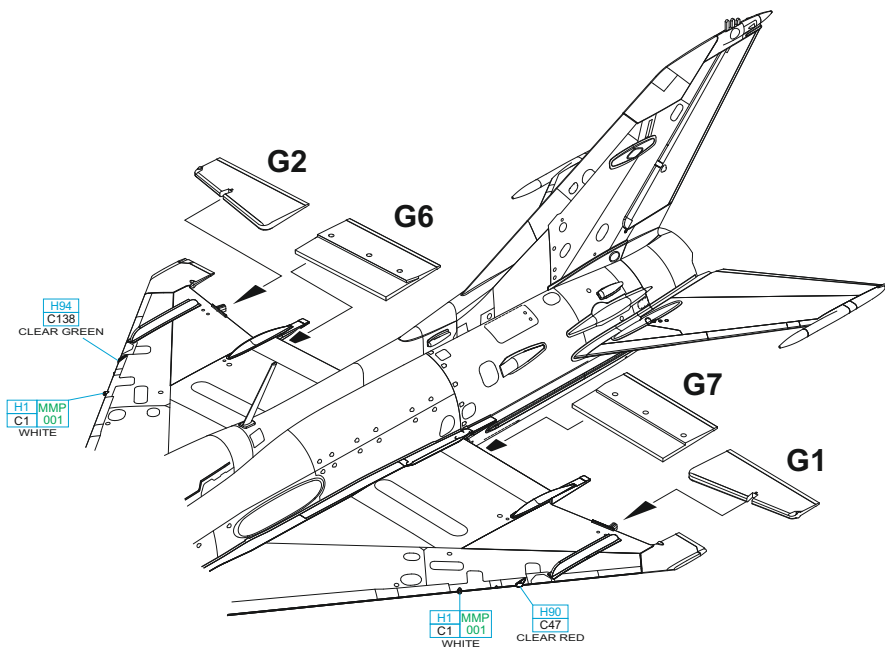
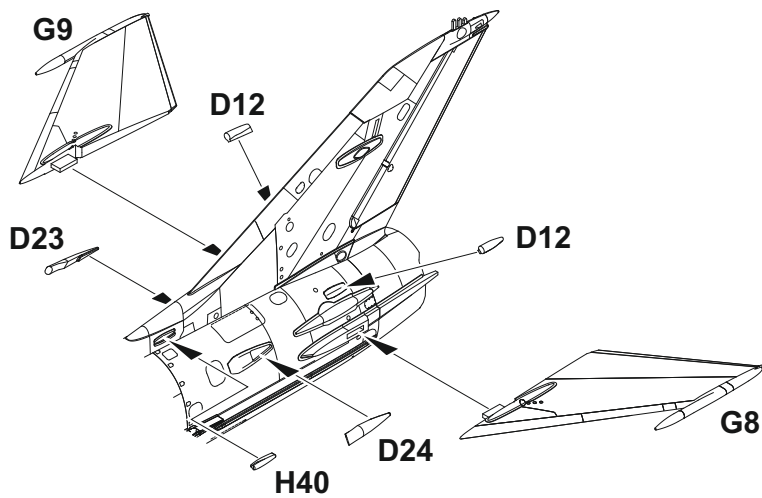

CLOSED
air brake H15

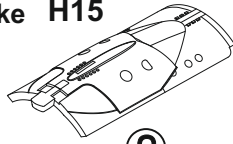

DEPLOYED
air brake H18

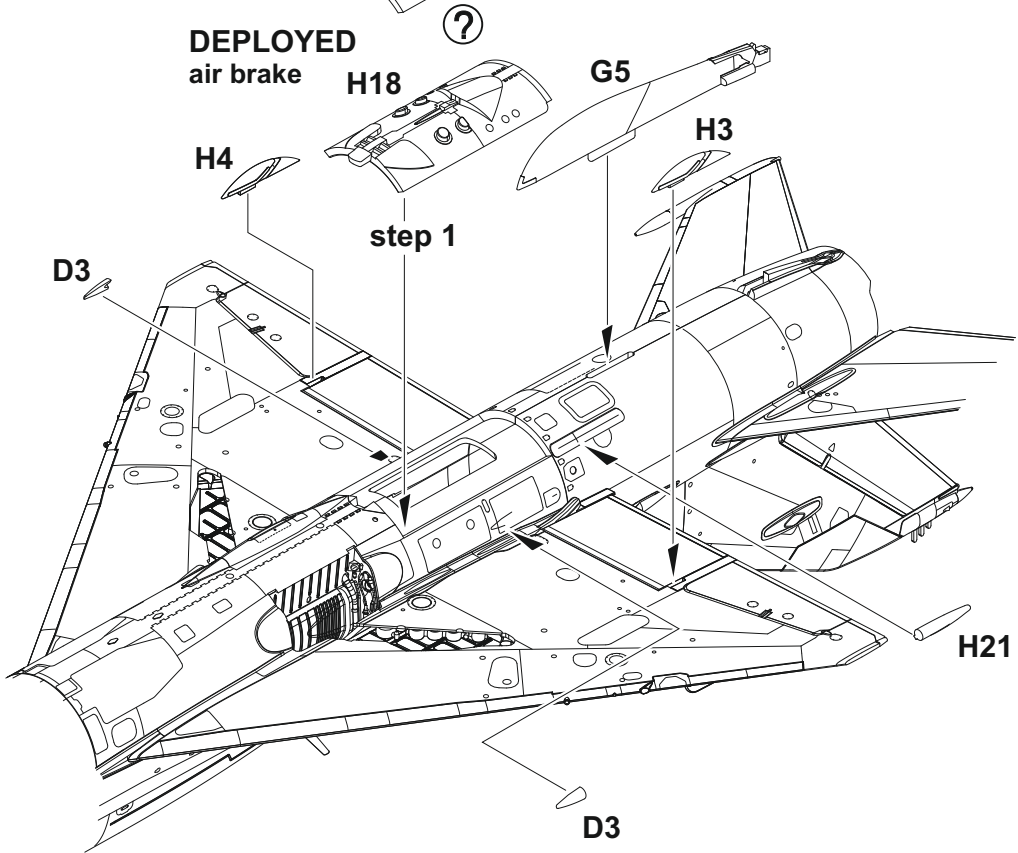
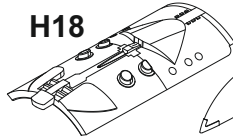

L

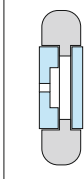

R

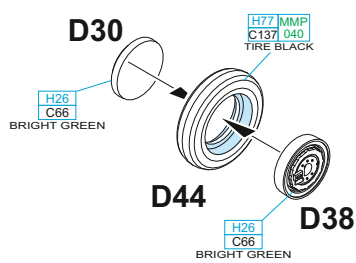
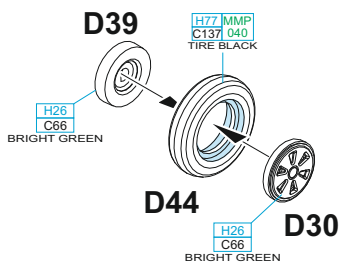
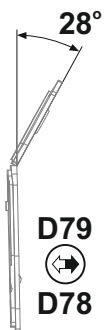
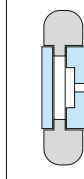

D77 - MARKING E ONLY

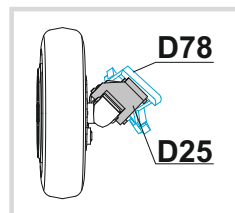
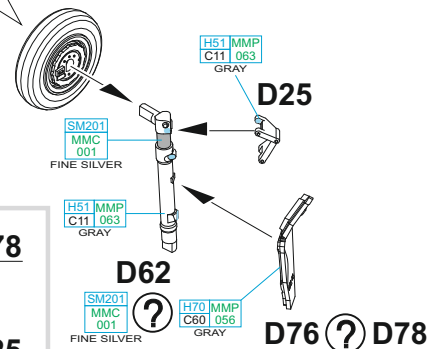
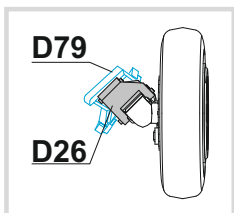
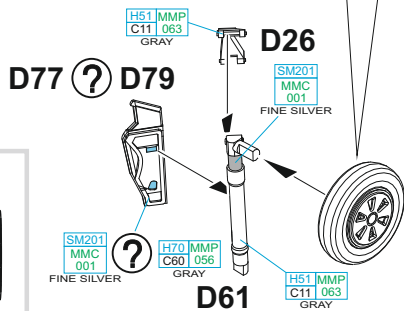

D76 - MARKING E ONLY

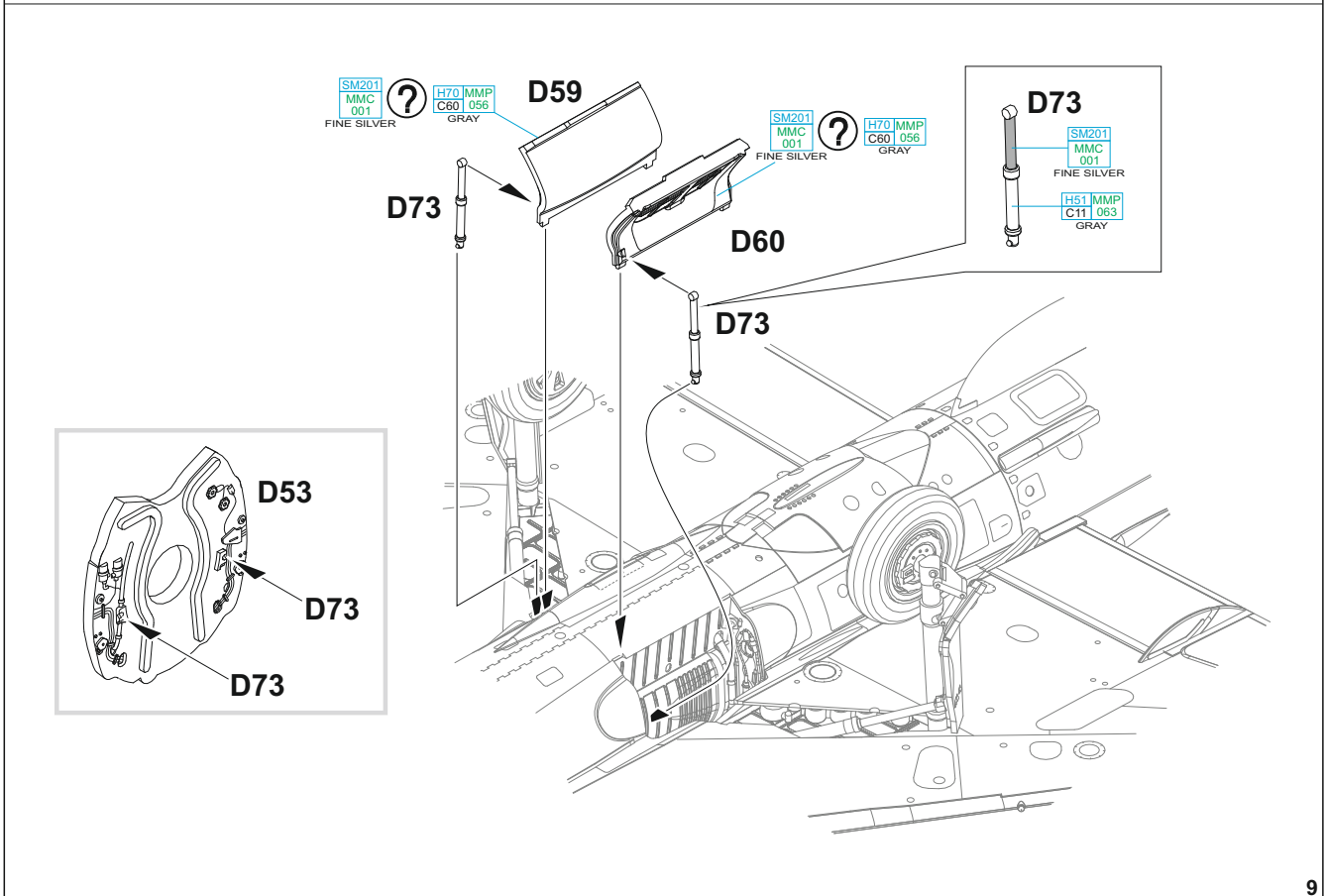
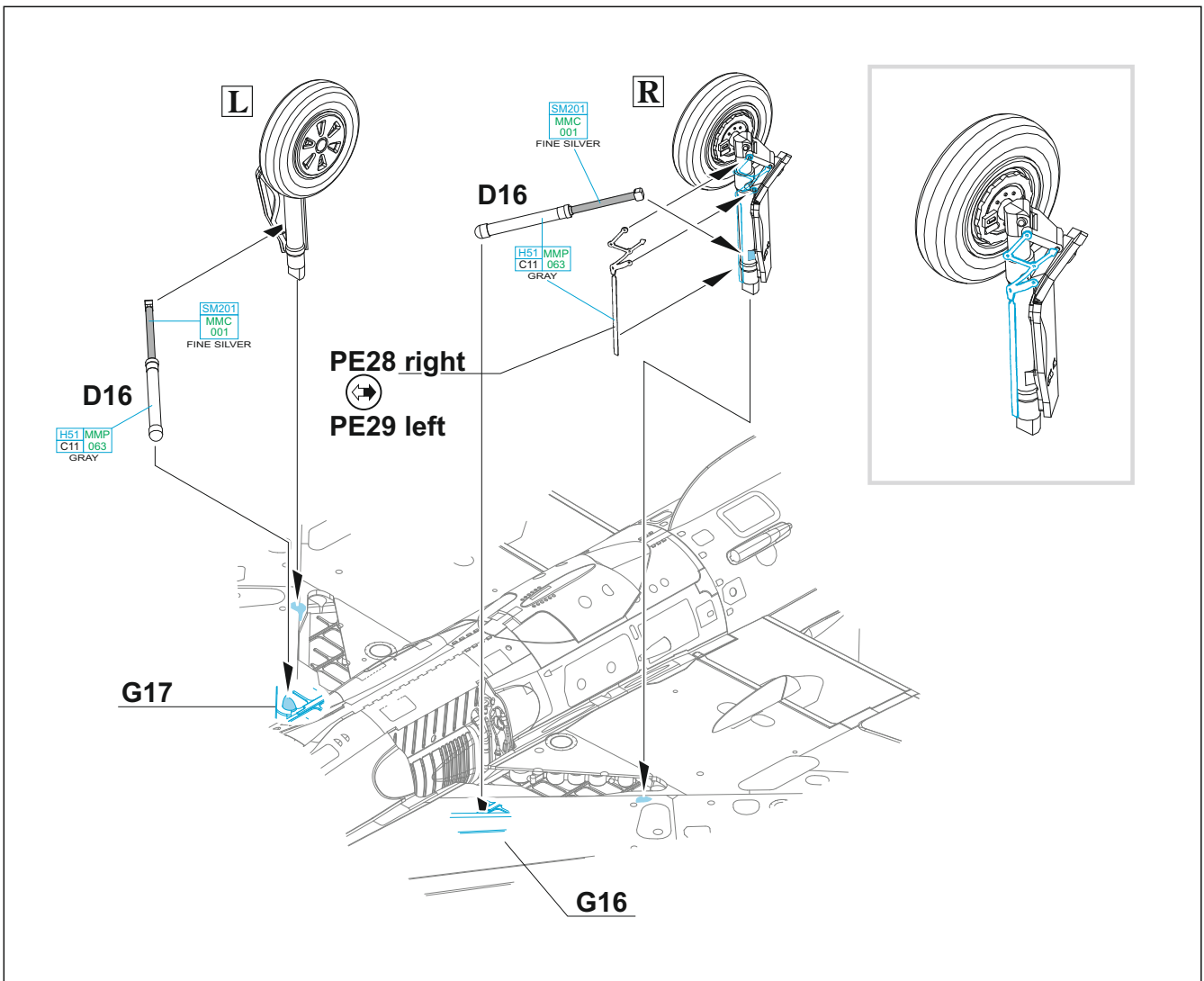

2 =

H4	MMP
C4	007
YELLOW	

 - MARKING **A**

UNDERSURFACE COLOR	
--------------------	--

 - MARKINGS **B;C;D;E**



DEPLOYED air brake
D45

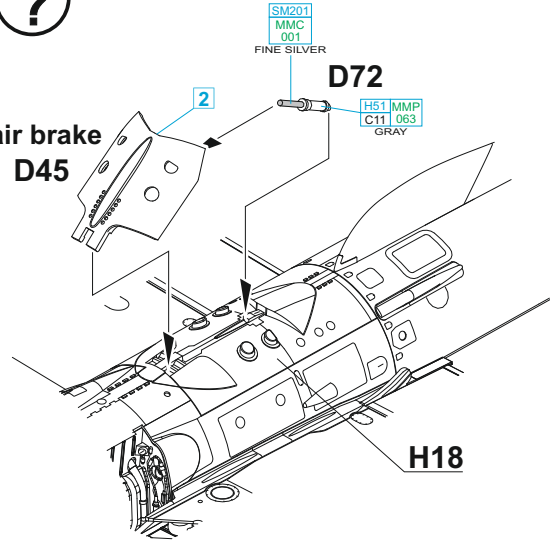
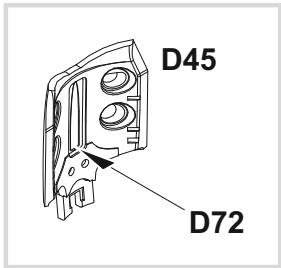

E

decal S123

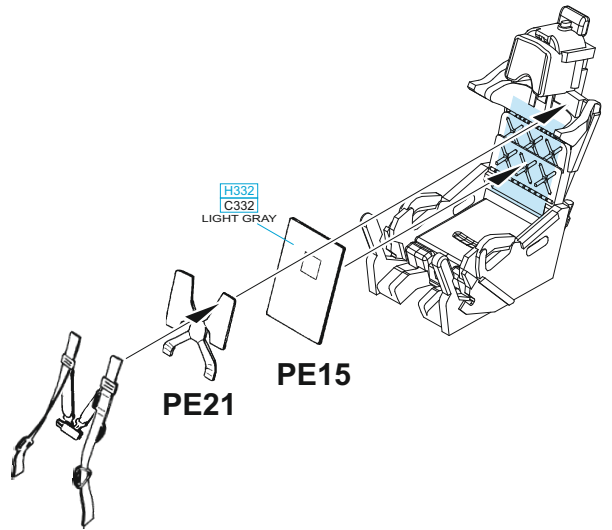
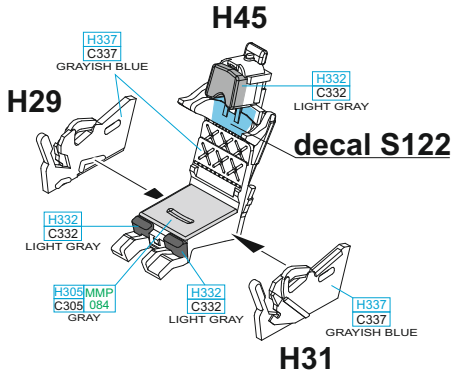

MARKING E ONLY

decal S123A

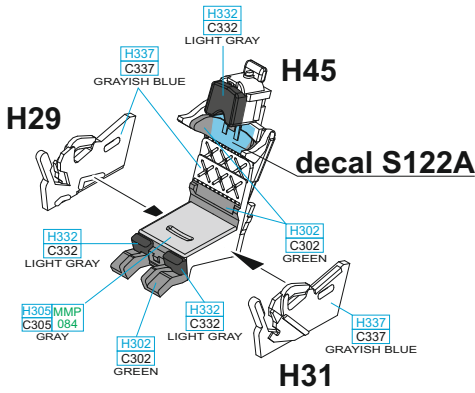

PE5

PE19 - this part was used in early years of service, then was often removed.

PE19 ↑ ?

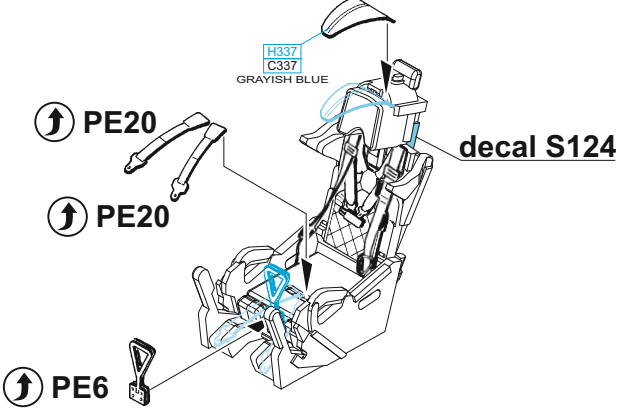

E

decal S125
MARKING E ONLY
decal S125

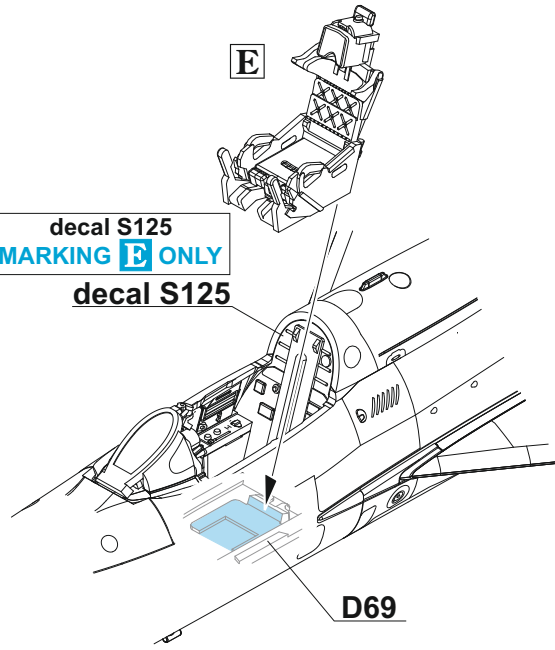

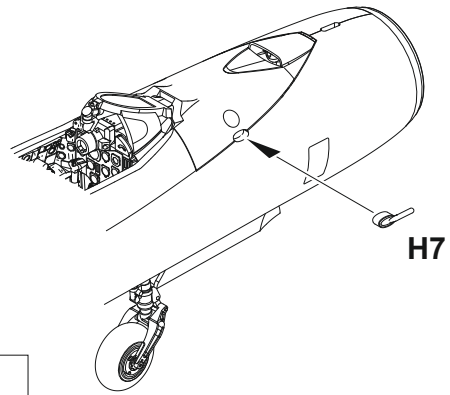

F

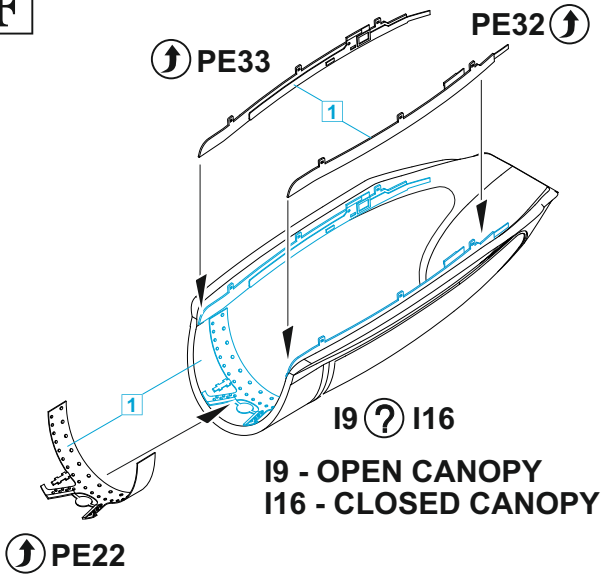

**CLOSED
CANOPY**

F

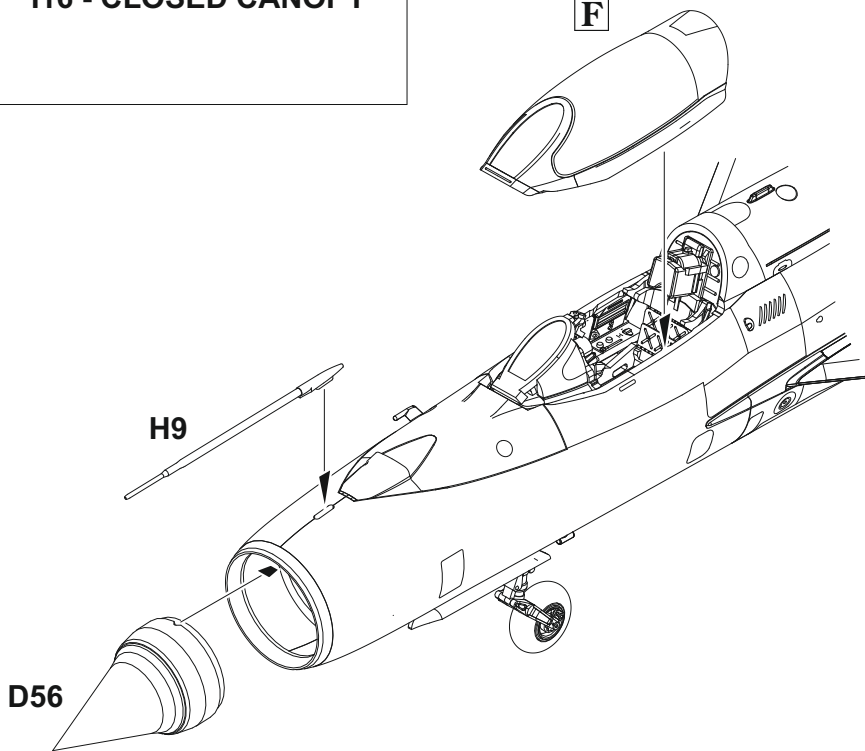

OPEN CANOPY

F

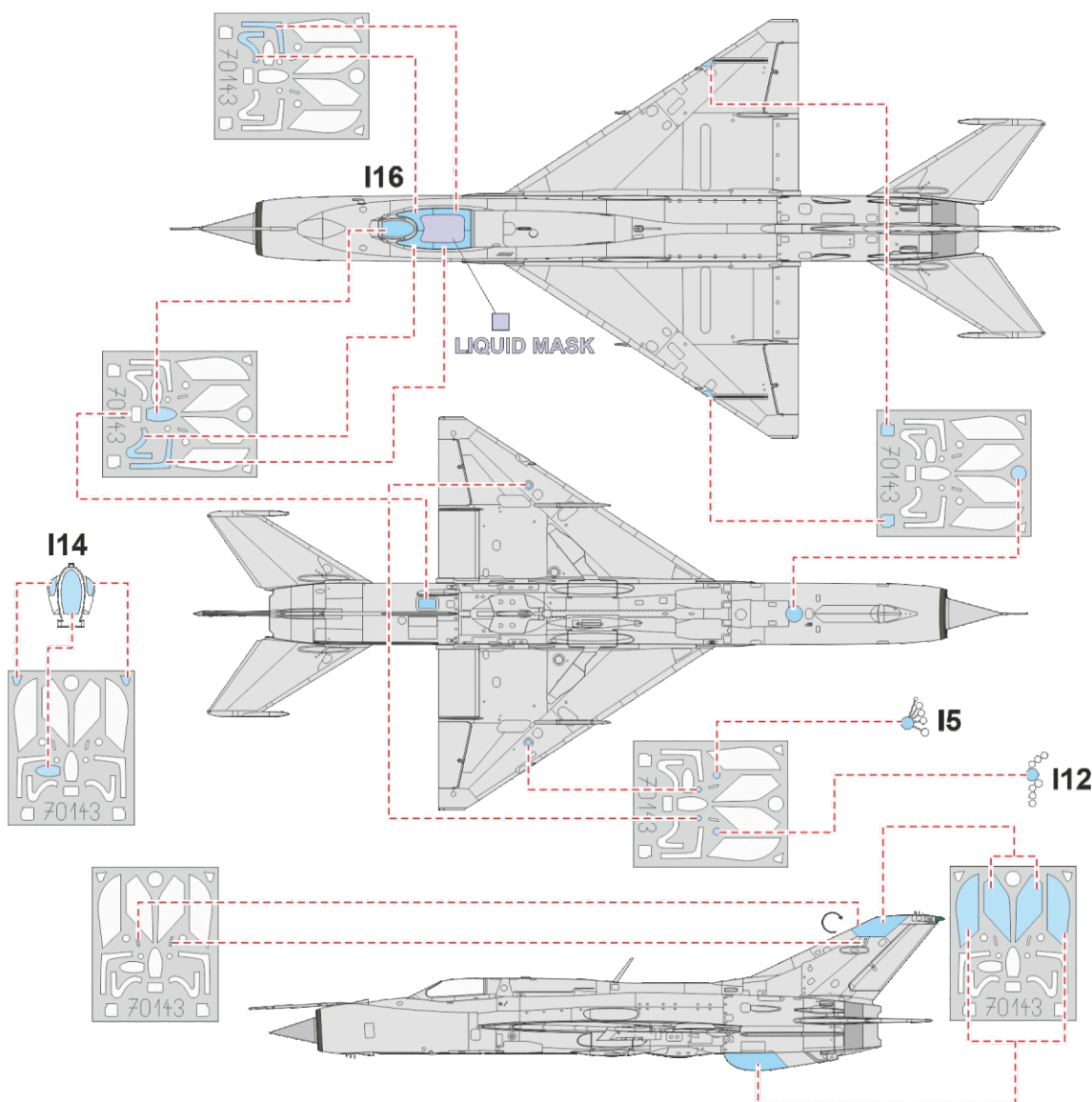
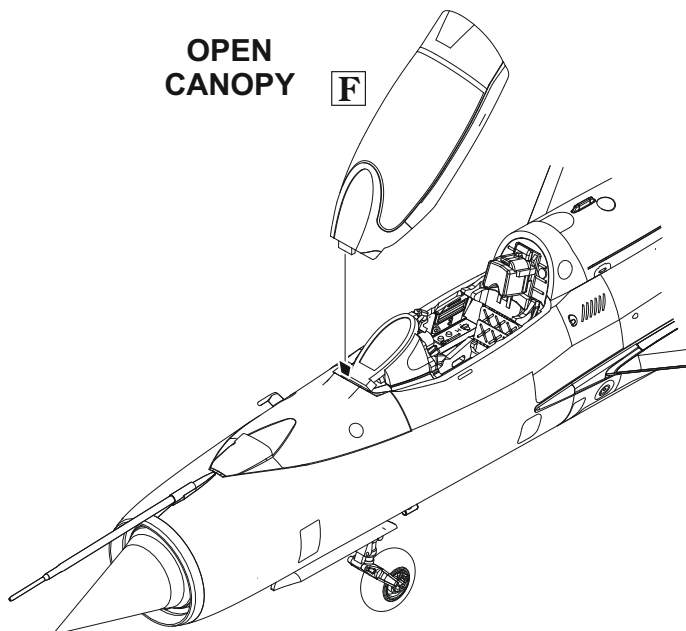

EXTERNAL FUEL TANK 490 I
PŘÍDAVNÁ NÁDRŽ 490 I

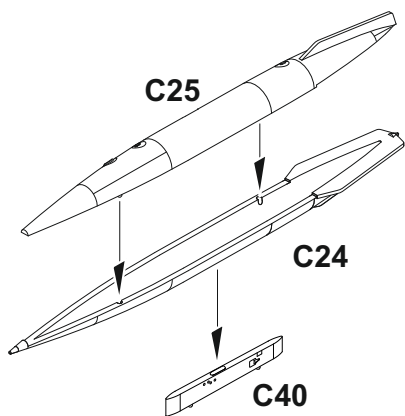

RS-2US
2 pcs.

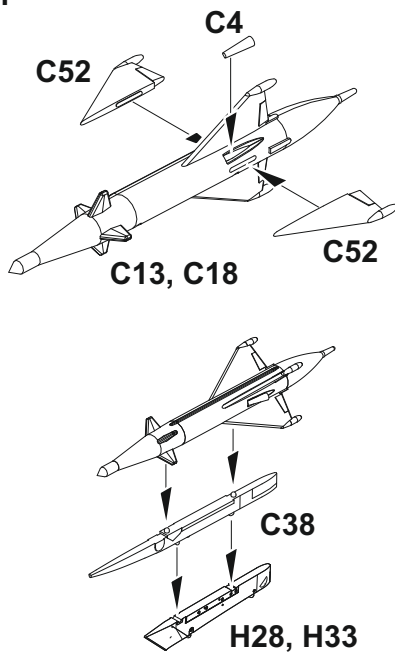

R-3S
2 pcs.

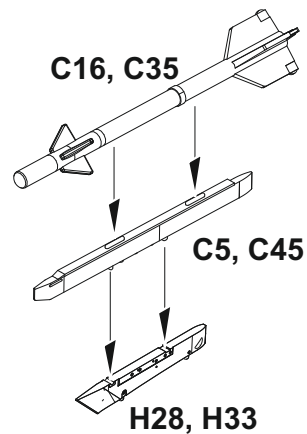

UB-16
2 pcs.

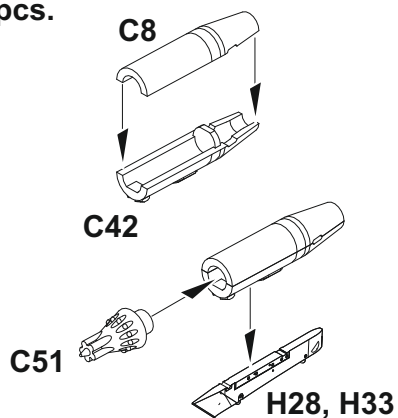

FAB 250
2 pcs.

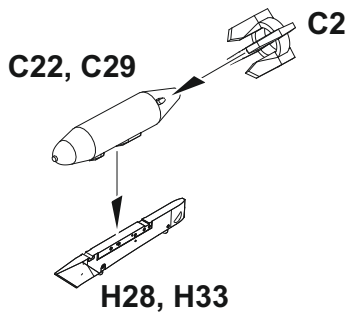

S-24
2 pcs.

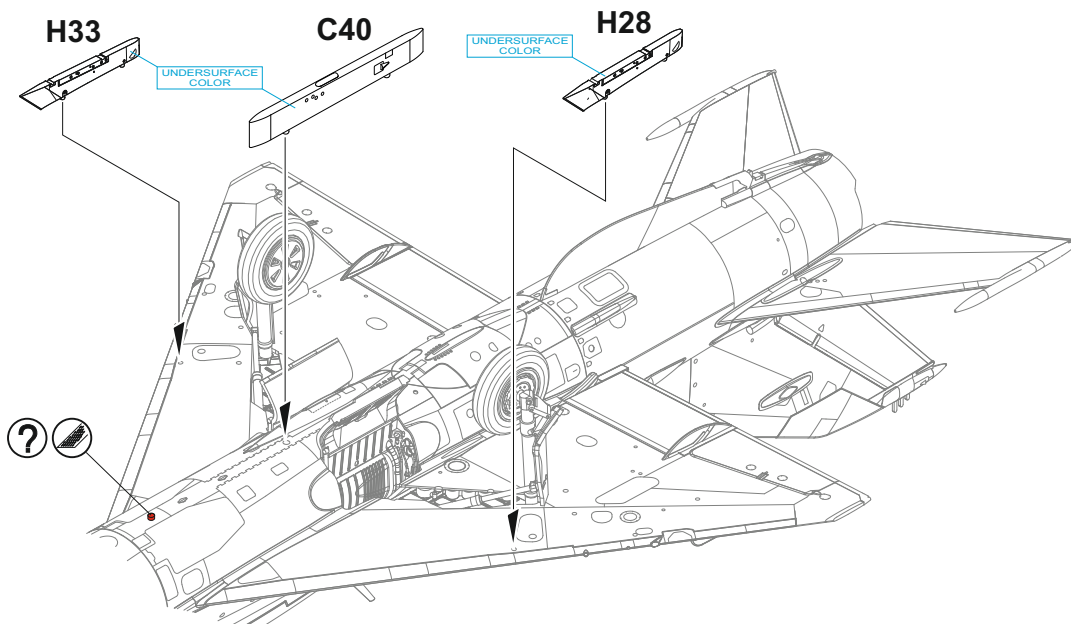
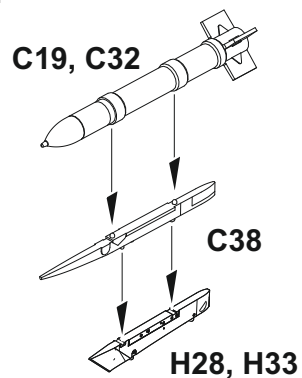

TO CHOOSE WEAPON AND EXTERNAL FUEL TANK OPTION PLEASE FOLLOW YOUR REFERENCE.

PRO VOLBU VÝZBROJE A PŘÍDAVNÝCH NÁDRŽÍ SE DRŽTE DOKUMENTACE KONKRÉTNÍHO STROJE.

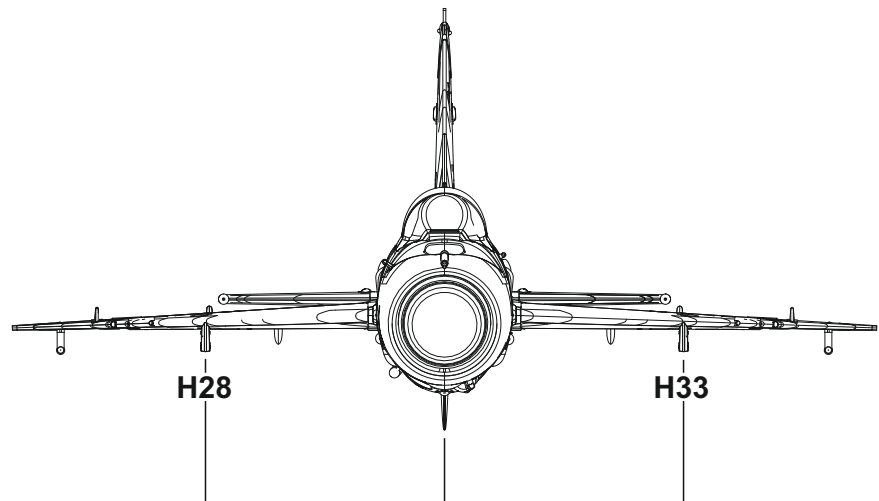

**EXTERNAL
FUEL
TANK 490 I**

|| C40



2x RS-2US

|| C38



|| C38



2x R-3S

|| C5



|| C45



2x S-24

|| C38



|| C38



2x FAB 250



2x UB-16



B Red 40, Soviet Air Force, Ceske Budejovice Air Base, Czechoslovakia, late August 1988

The MiG-21PF "Red 40" was part of the force deployed during the invasion of the Warsaw Pact forces to the Czechoslovakia in August, 1968 (the operation codenamed "Operation Danube"). This aircraft had been based at the Ceske Budejovice air base for first weeks following the invasion. Two red bands on the tail marked the aircraft participating in the Operation Danube. Cockpit was painted grey.

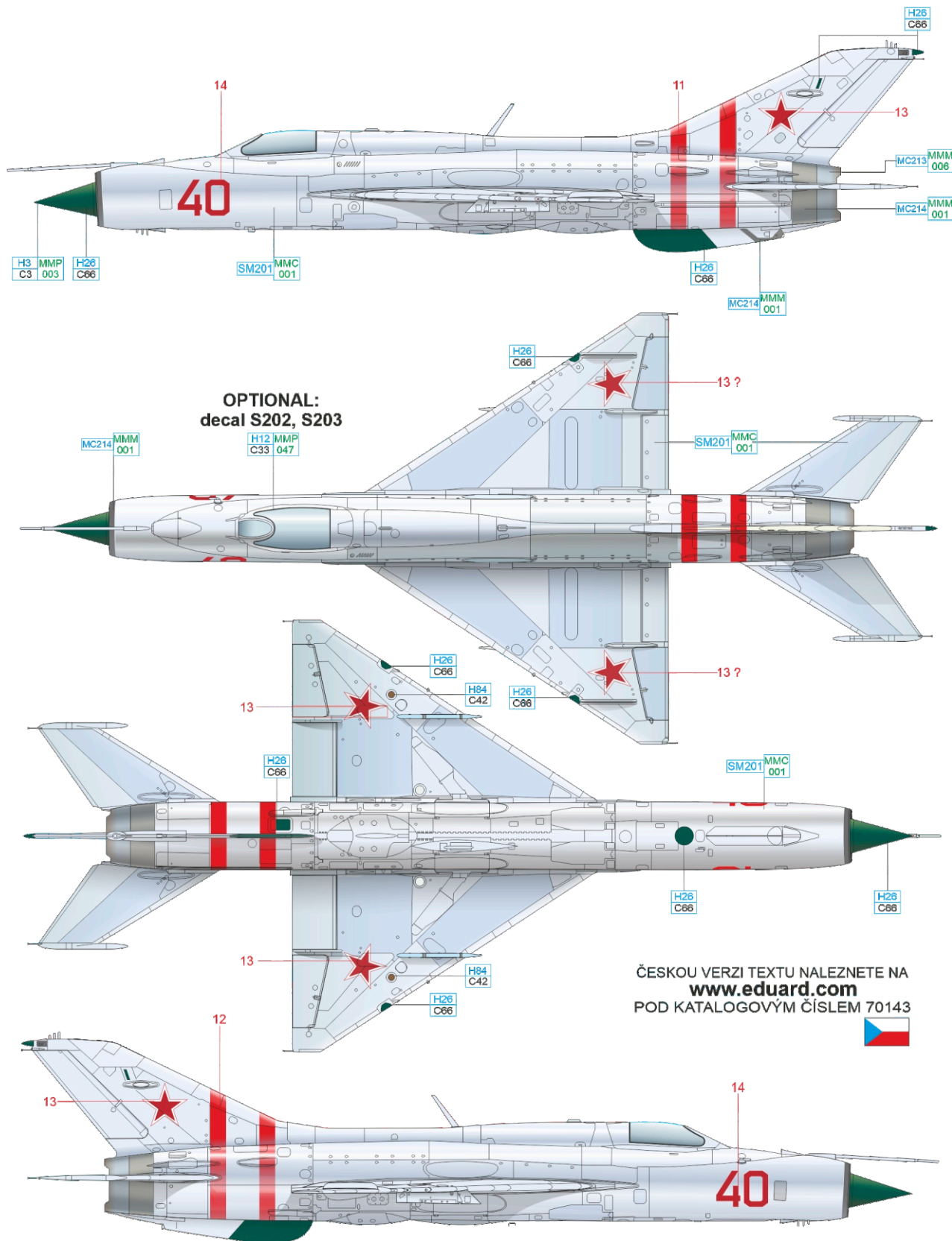

OPTIONAL:
decal S202, S203

ČESKOU VERZI TEXTU NALEZNETE NA
www.eduard.com

POD KATALOGOVÝM ČÍSLEM 70143



SUPER FINE SILVER	SM201	MMC 001					
DARK IRON	MC214	MMM 001	BLACK	H12 C33	MMP 047	BRIGHT GREEN	H26 C66
STEEL	MC213	MMM 006	RED	H3 C3	MMP 003	MAHOGANY	H84 C42

The air force of the GDR received this aircraft on May 1, 1965. The aircraft was flown by JG8, JG9 and finally by JG2. After that, it was put out of service in 1988 and scrapped shortly afterwards despite a plan to sell it to Iran. This MiG-21PF became well known thanks to a propaganda movie. The fuselage number was changed to "Red 1851" for filming. The Q-badge painted on the left side of the nose indicated that the ground personnel responsible for this aircraft were recognized for the high quality of their work. Cockpit had a turquoise color.

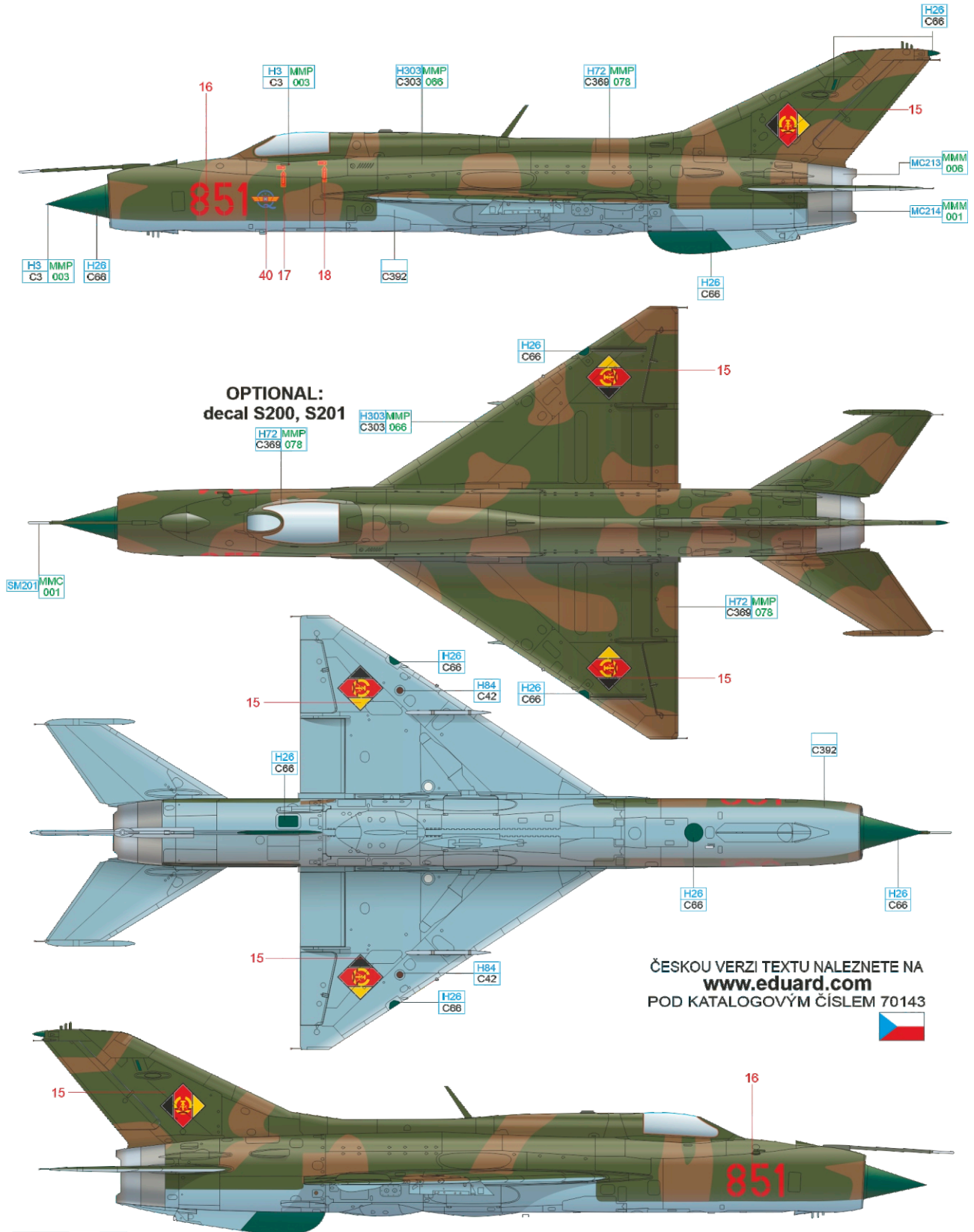

ČESKOU VERZI TEXTU NALEZNETE NA
www.eduard.com
 POD KATALOGOVÝM ČÍSLEM 70143



STEEL	MC213	MMM006								
DARK IRON	MC214	MMM001	RED	H3 C3	MMP003	BRIGHT GREEN	H26 C66	LIGHT BLUE	C392	
SUPER FINE SILVER	SM201	MMC001	GREEN	H303 C303	MMP066	MAHOGANY	H84 C42	BROWN	H72 C368	MMP078

D Red 4326, 921st Fighter Regiment, North Vietnam, Late 60s/Early 70s

This aircraft was delivered to Vietnam in 1966 and served as a part of the 921st Fighter Regiment. Thirteen red stars were painted on the nose to depict victories gained by the pilots who flew this aircraft. One of them was Nguyen Van Coc, the most successful Vietnamese fighter ace with nine confirmed kills to his credit. He downed F-4B BuNo. 151485 on May 7, 1968 while at the controls of this MiG-21PFL. "Red 4326" is currently displayed in Air Force museum in Hanoi. Cockpit has a grey color.

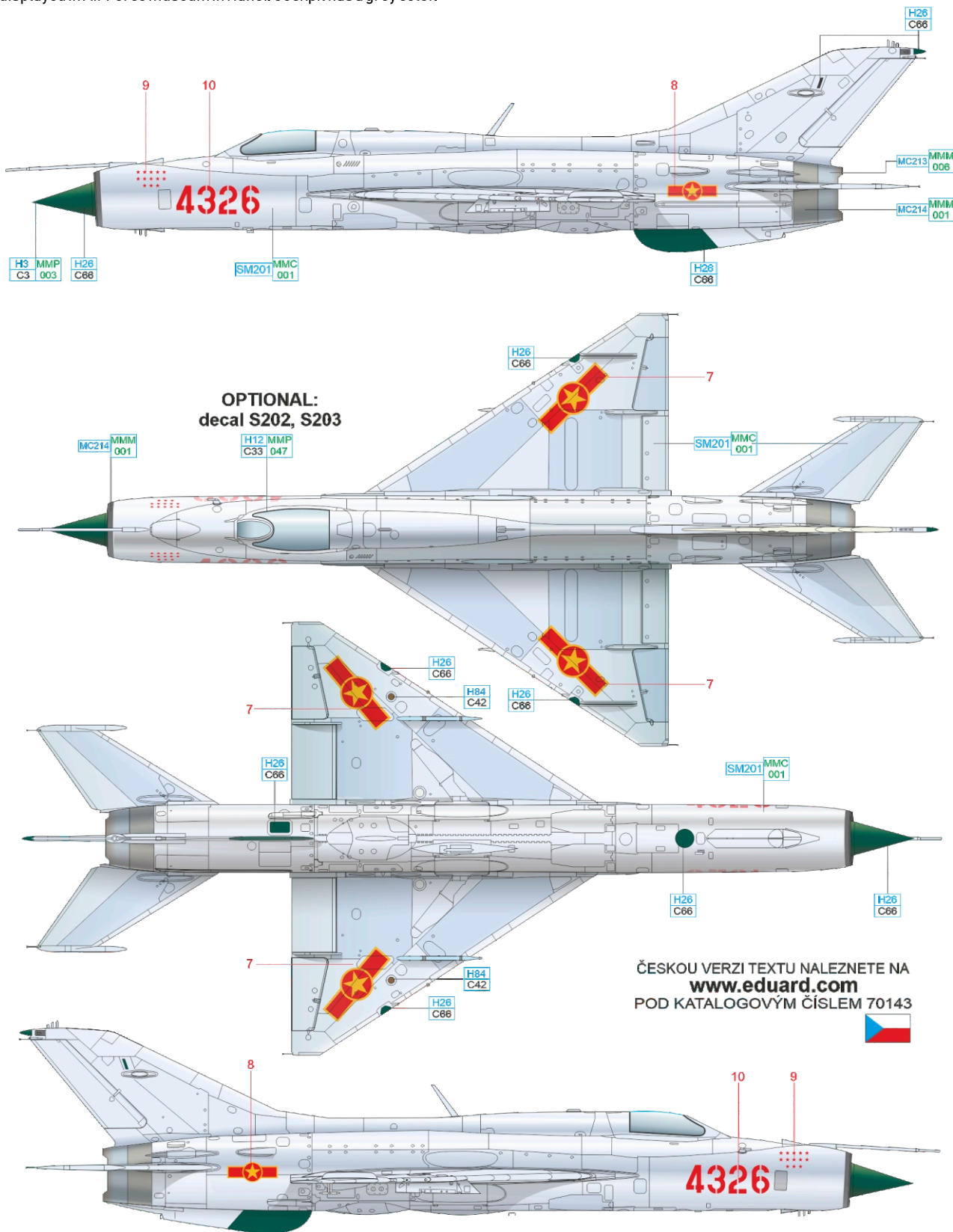

OPTIONAL:
decal S202, S203

ČESKOU VERZI TEXTU NALEZNETE NA
www.eduard.com

POD KATALOGOVÝM ČÍSLEM 70143



SUPER FINE SILVER	SM201	MMC 001			
DARK IRON	MC214	MMM 001	BLACK	H12 MMP C33 047	BRIGHT GREEN H26 C66
STEEL	MC213	MMM 006	RED	H3 C3 003	MAHOGANY H84 C42

E Red 409, serial no. 760409 31st T. F. W, Tazsár Air Base, Hungary, 1987-88

The aircraft served with the Tazsár based 31st T. F. W. (Tactical Fighter Wing) as a part of the 1st squadron. In the first half of its service years it didn't have any camouflage and just sported the natural metal finish. The aircraft sustained heavy damage due to an on-board fire during one flight, however the pilot managed to land the plane. Due to the repair the aircraft was out of service for long and returned to the unit in its natural metal finish. The new camouflage paint scheme was applied at the Pestvidéki Gépgyár company during the last overhaul in November, 1980. After the overhaul, the cockpit had turquoise color. Hungarian MiG-21PFs were withdrawn from service on January 1, 1989. In the last days of its life, the 409 was used for trials, testing possible future national marking variations to replace the communist era red stars. Plane was scrapped at the Kecskemet AB.

Camouflage colour overspray on metal surface.

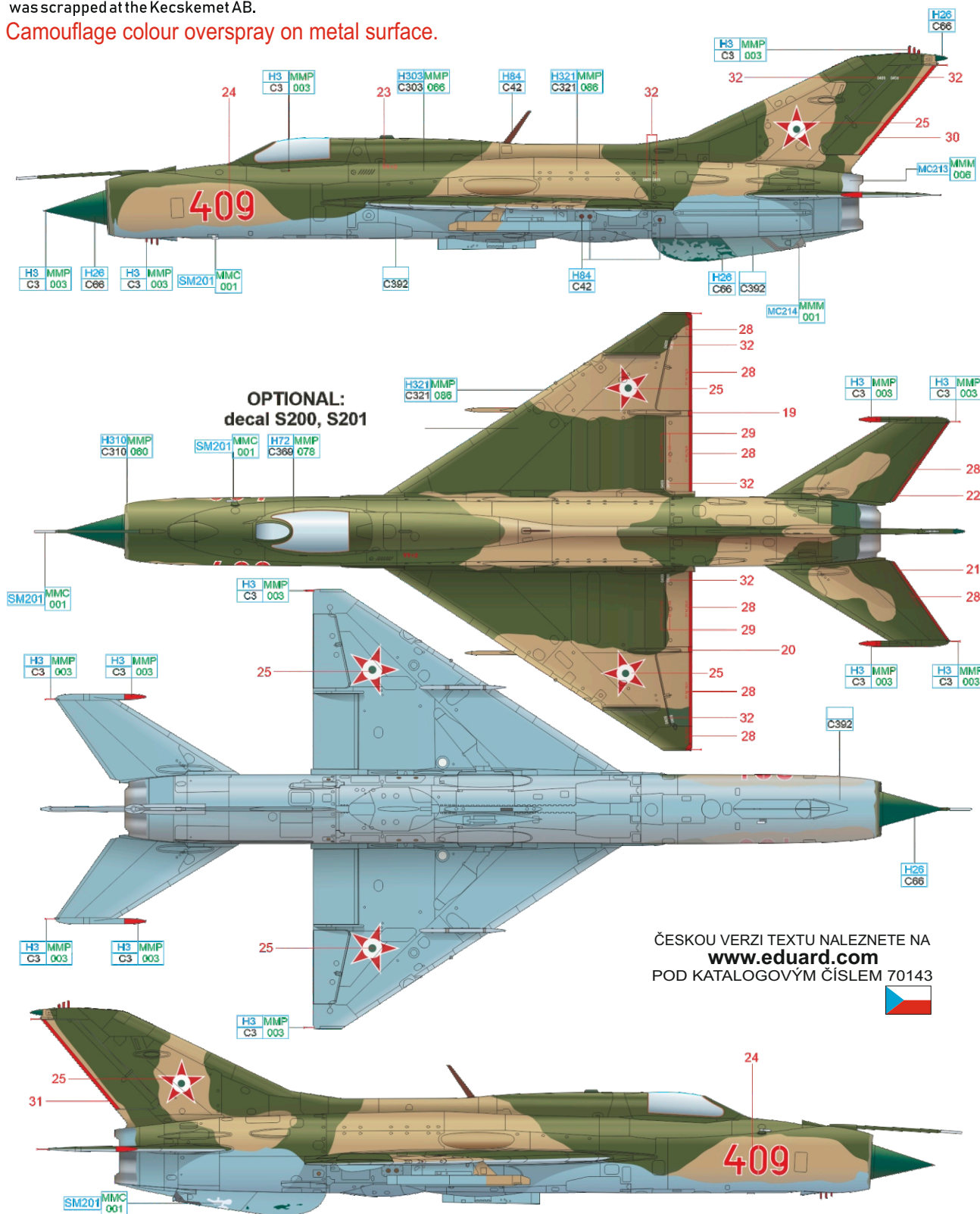

ČESKOU VERZI TEXTU NALEZNETE NA
www.eduard.com
 POD KATALOGOVÝM ČÍSLEM 70143



DARK IRON	MC214	MMM 001	LIGHT BROWN	H321 MMP C321 086	GREEN	H303 MMP C303 066	LIGHT BLUE	C392	SUPER FINE SILVER	SM201	MMC 001	
STEEL	MC213	MMM 006	RED	H3 MMP C3 003	BROWN	H310 MMP C310 060	BRIGHT GREEN	H26 C66	BROWN	H72 MMP C369 078	MAHOGANY	H84 C42

Researched by Gabor Szekeres



FUSELAGE PYLON PODTRUPOVÝ PYLON

C40

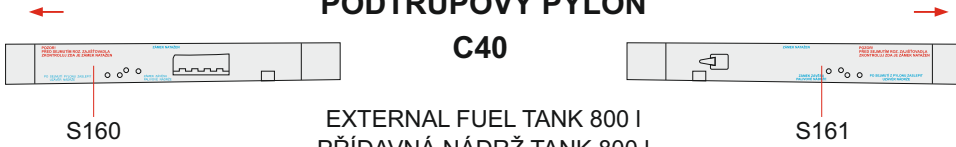

LEFT PYLON LEVÝ PYLON

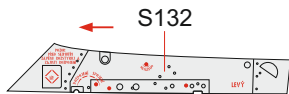

UB-16, FAB 250

RIGHT PYLON PRAVÝ PYLON

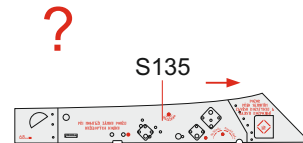
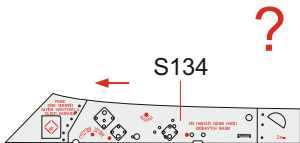
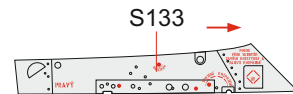

LEFT APU-7 LEVÉ APU-7

C38

RS-24S, S-24

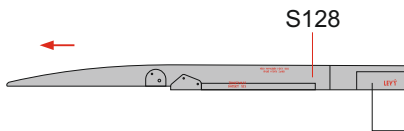

RIGHT APU-7 PRAVÉ APU-7

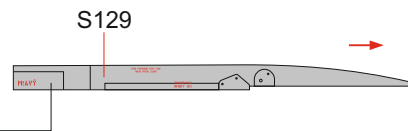

SM201
MMC
001

LEFT APU-13 LEVÉ APU-13

C5, C45

R-3S



RIGHT APU-13 PRAVÉ APU-13



SM201
MMC
001

EXTERNAL FUEL TANK 800 I PŘÍDAVNÁ NÁDRŽ TANK 800 I

TOP

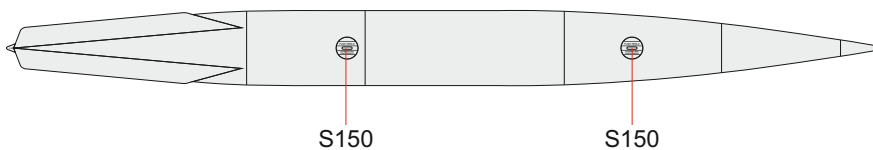

S1 - S161 - MARKING **A**

S1 - S161 - MARKINGS **B; C; D**

S1 - S161 - FOR UPPER SURFACES
ON CAMOUFLAGE COLOR

