

Bf 109F-4

eduard

1/72 Scale Plastic Model Kit

ProfiPACK
edition



item No. 70155

No other aircraft is as intimately connected with the rise and fall of the German Luftwaffe in the course of the WWII as the Messerschmitt Bf 109. A very progressive design at the time of its invention, it had plenty of room for further development.

The history of the Bf 109 begins with the requirement L.A. 1432/33 issued by Reich Ministry of Aviation (RLM) in late March 1933. It called for the development of a single-engined monoplane fighter. Proposals were submitted by Arado, Heinkel, Focke-Wulf and Bayerische Flugzeugwerke. The design bureau of the last-mentioned company was led by its technical director Willy Messerschmitt, who was riding a wave of popularity based on the success of his liaison aircraft, the Bf 108. Messerschmitt's goal was to create an aircraft with the best possible performance for the specified weight and size. Over the following months, several prototypes were built that served first and foremost in development flights and further modifications. The aircraft was relatively small, and compared to the prevailing trends of the time, sported several quite revolutionary features such as low wing design, retractable landing gear, wing with a thin airfoil, wing slats, landing flaps, weapons firing through the propeller hub, and so on. Even the enclosed cockpit and the method of the airframe structure design were not usual just four years prior to the beginning of the Second World War. At its conception, the Bf 109 was a very promising asset despite some powerplant troubles. These were solved by the introduction of the DB 601. This engine, together with its extrapolated development DB 605, is umbilically connected to the success of the Bf 109. These two-row, twelve-cylinder inverted V engines powered several tenths of thousands of Bf 109s in over 25 versions and variants.

From Spanish War to the Reich Defence

The first combat use of Bf 109 occurred during Spanish Civil War, where three developmental Bf 109s were deployed in December 1936. The main reason of revealing the modern fighter to the world was quite down-to-earth: To validate its abilities in modern aerial combat. Shortly thereafter, production aircraft in the form of the Bf 109B-1 began to reach 2.J/88, the Legion Condor. The desire of Germany to demonstrate its aerial prowess to potential foes was advanced further in international sport meets. The triumph attained in Zurich in the summer of 1937 was complemented several months later by grabbing the speed record of 379.63 mph (610.95 km/h). In very short order, the progressive developments represented by the C, D and E versions appeared. Despite this, the delivery of the aircraft to combat units did not sustain the rate desired by military brass. Even by August 1938 the Bf 109 accounted for less than half of the 643 front line fighters in service. The next months saw an increase in these rates. By the time of the invasion of Poland (which saw the participation of only a little more than 200 aircraft) the Luftwaffe possessed the best fighter produced in continental Europe. So the fighter wing of the Luftwaffe entered the Polish campaign, the Blitzkrieg against the West, and the Battle for France with both a qualitative and quantitative advantage. With one foot in the door that was the English Channel, the Luftwaffe embarked on the attacks

on Britain in the summer months of 1940. Here, the first weakness of the Bf 109 emerged: The inability to carry drop tanks that would have enabled the type to effectively escort bombers to England. This was one of the factors responsible for the defeat of the Luftwaffe in the Battle of Britain. Experience gained in 1940 led to the development of the F version prior to the spring of 1941. The elegance of the Bf 109 crested with the "Friedrich". Following a largely defensive stance over the Channel and northern France, the Bf 109F took on a more offensive role in Operation Barbarossa in the east, and in northern Africa. In later duties with the "Jagdwaaffe" during the second phase of the war in the east, and in the "Defence of the Reich" from 1943 to 1945, the Bf 109s served in the form of the G version, followed by the K. Even if it was clear that the development of the Bf 109 had reached its limits by the end of the war, the aircraft was still able to keep pace with the foes that it encountered. Besides its primary purpose as a fighter, the Bf 109 also appeared as a fighter-bomber, reconnaissance platform, night fighter, trainer and rammjäger.

Postwar service

The disappearance of the Bf 109 from the skies over Europe was not spelled out by the end of the war. Several examples stayed in Swiss service up to 1949 and many flew in the air force of Czechoslovakia in both original form with a DB 605 powerplant and as an aircraft built out of necessity with surplus Jumo 211s. The latter type also served as the first fighter to fight for the independence of the newly formed state of Israel. Finland retired the type as recently as 1954, and Spain did not retire its HA-1109-1112, re-engined Bf 109s, until 1967. The legendary low-wing fighter of Professor Willy Messerschmitt survived the state that developed it.

The kit: Bf 109F-4

The Bf 109F series (Friedrich) was a major improvement over its predecessor, the Bf 109E. There were numerous aerodynamical changes, giving the Bf 109 the shape, which was close to its final appearance. The engine cowling was completely redesigned and was more rounded and streamlined. The spinner was larger, and its shape transitioned smoothly into the line of the front fuselage. The oil cooler radiator below the nose was also streamlined. The wing lost its typical rectangle shape, as a new, rounded wingtips were developed. The armament was also revised and consisted of two .312 (7.92 mm) MG 17 machine guns mounted on top of the engine and one 20mm cannon firing through the propeller spindle. The new aircraft was well received as it was the best handling Bf 109 of them all. The F-4 sub-variation was using VDM 9-12010 propeller with broader blades and was armed with the new cannon Mauser MG 151/20. The first Bf 109F-4s arrived in June 1941 and the production ran from the May 1941 to the same month a year later. During that period 1,841 of the Bf 109F-4 were produced.

ATTENTION



UPOZORNĚNÍ



ACHTUNG



ATTENTION



注意



Carefully read instruction sheet before assembling. When you use glue or paint, do not use near open flame and use in well ventilated room. Keep out of reach of small children. Children must not be allowed to suck any part, or pull vinyl bag over the head.



Před započítím stavby si pečlivě prostudujte stavební návod. Při používání barev a lepidel pracujte v dobře větrané místnosti. Lepidla ani barvy nepoužívejte v blízkosti otevřeného ohně. Model není určen malým dětem, mohlo by dojít k požití drobných dílů.

INSTRUCTION SIGNS * INSTR. SYMBOLS * INSTRUKTION SINNBILDEN * SYMBOLES * 記号の説明

OPTIONAL
VOLBABEND
OHNOUTSAND
BROUSITOPEN HOLE
VYVRTAT OTVORSYMETRICAL ASSEMBLY
SYMETRICKÁ MONTÁŽREMOVE
ODŘÍZNOUTREVERSE SIDE
OTOČITAPPLY EDUARD MASK
AND PAINT
POUŽIT EDUARD MASK
NABARVITPLEASE CHECK THE LATEST VERSION OF THE INSTRUCTIONS ON www.eduard.com

PARTS



DÍLY



TEILE



PIÈCES



部品

PLASTIC PARTS

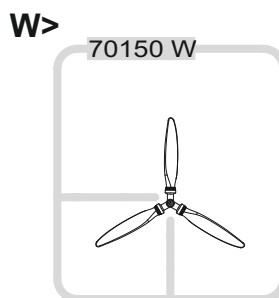
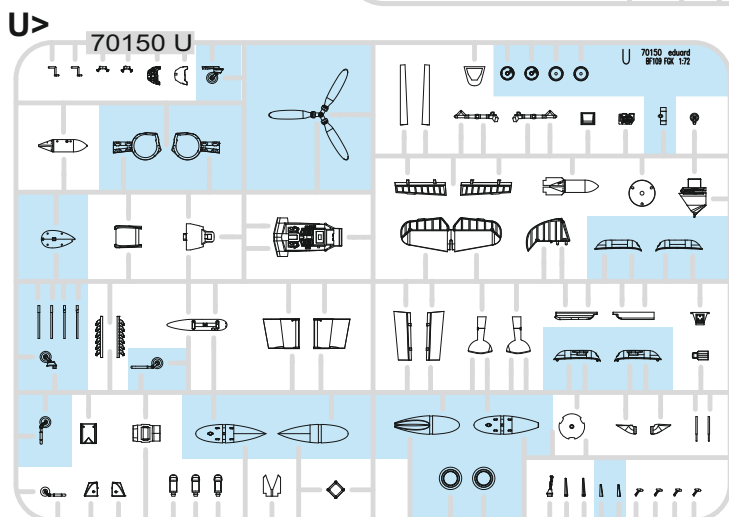
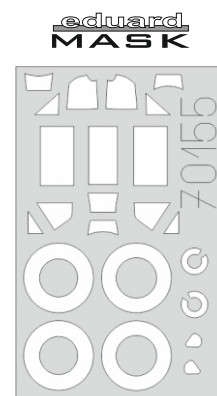
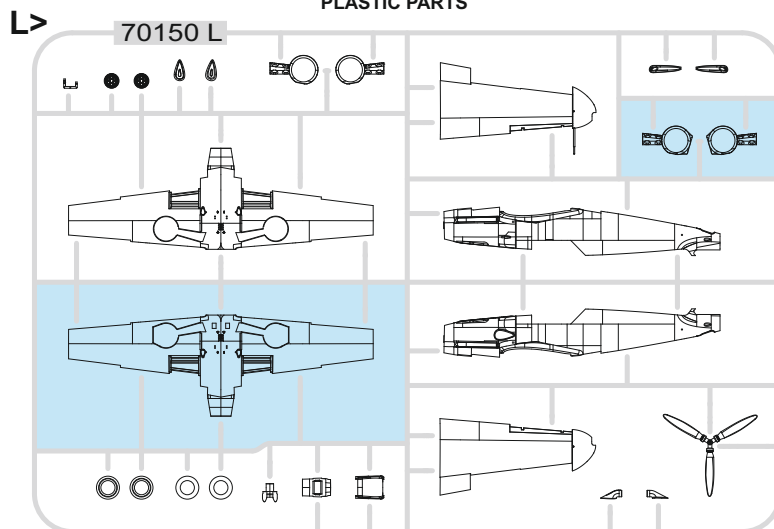
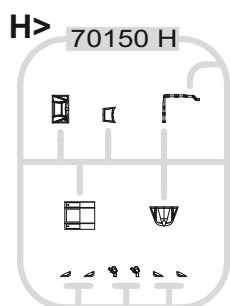
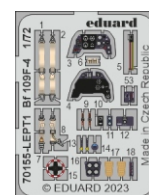
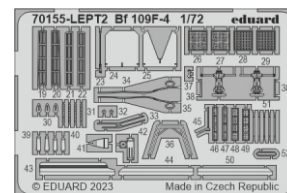
PE - PHOTO ETCHED
DETAIL PARTS

-Parts not for use. -Teile werden nicht verwendet. -Pièces à ne pas utiliser. -Tyto díly nepoužívejte při stavbě. - 使用しない部品

COLOURS



BARVY



FARBEN



PEINTURE



色

GSI Creos (GUNZE)		
AQUEOUS	Mr.COLOR	
H1	C1	WHITE
H2	C2	BLACK
H11	C62	FLAT WHITE
H12	C33	FLAT BLACK
H47	C41	RED BROWN
H51	C11	LIGHT GULL GREY
H64	C17	RLM71 DARK GREEN
H65	C18	RLM70 BLACK GREEN
H66	C119	RLM79 SAND YELLOW
H68	C36	RLM74 DARK GRAY
H69	C37	RLM75 GRAY
H70	C60	RLM02 GRAY
H77	C137	TIRE BLACK
H80	C54	KHAKI GREEN

GSI Creos (GUNZE)		
AQUEOUS	Mr.COLOR	
H90	C47	CLEAR RED
H94	C138	CLEAR GREEN
H413	C113	RLM04 YELLOW
H414	C114	RLM23 RED
H416	C116	RLM66 BLACK GRAY
H417	C117	RLM76 LIGHT BLUE
H418	C118	RLM78 LIGHT BLUE
Mr.METAL COLOR		
MC213		STEEL
MC214		DARK IRON
Mr.COLOR SUPER METALLIC		
SM201		SUPER FINE SILVER
Mr.COLOR GX		
GX05		SUSIE BLUE

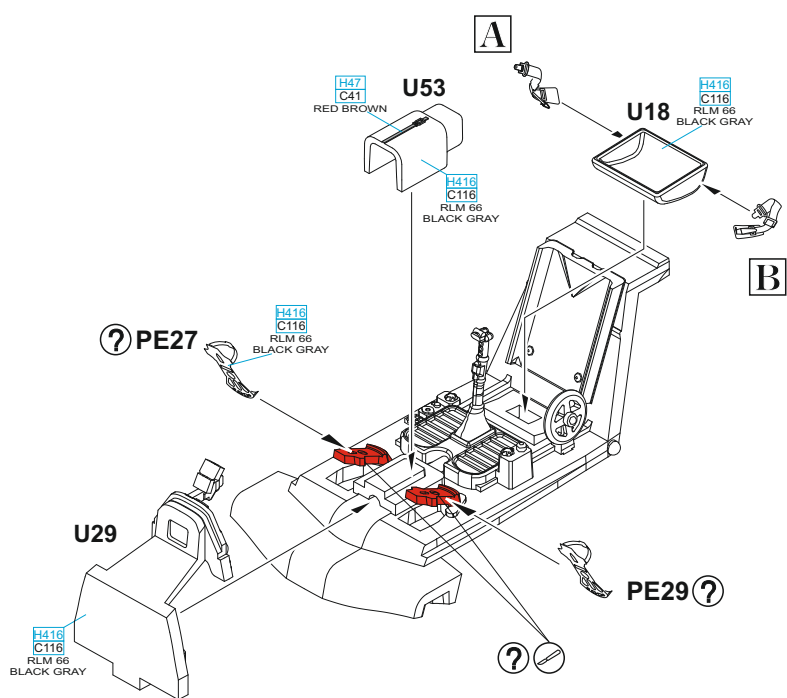
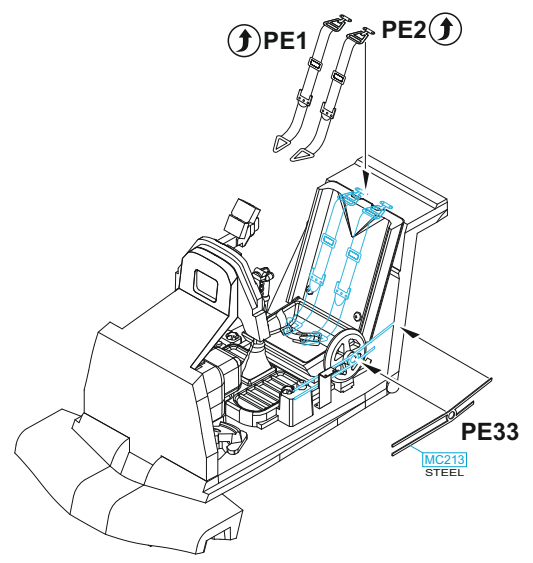
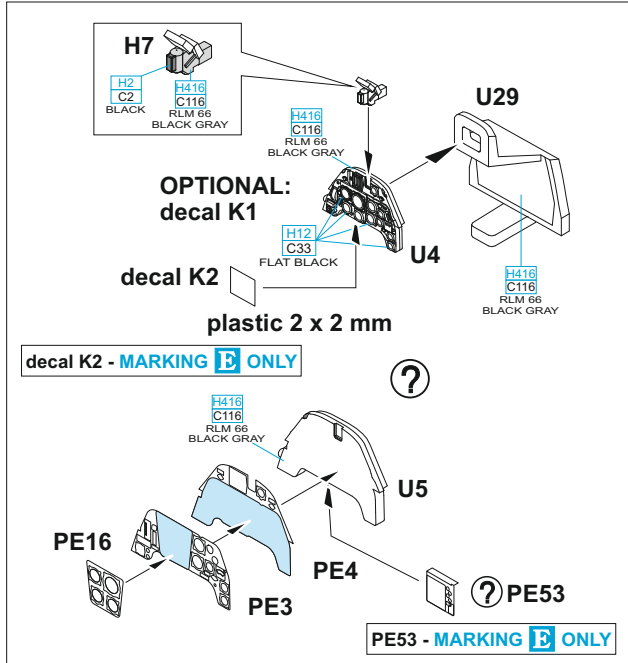
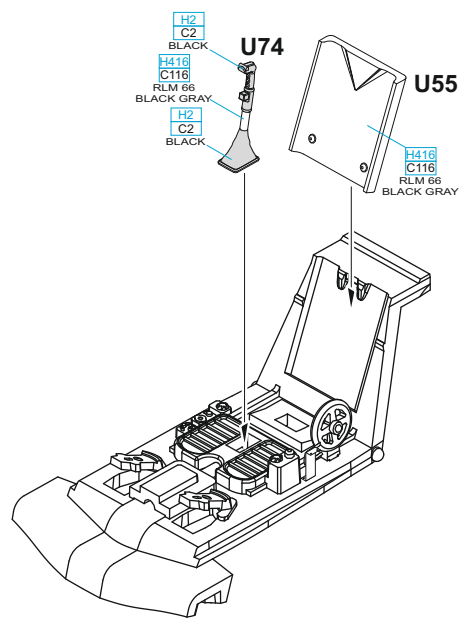
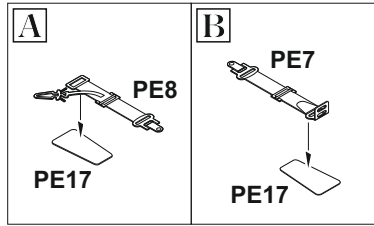
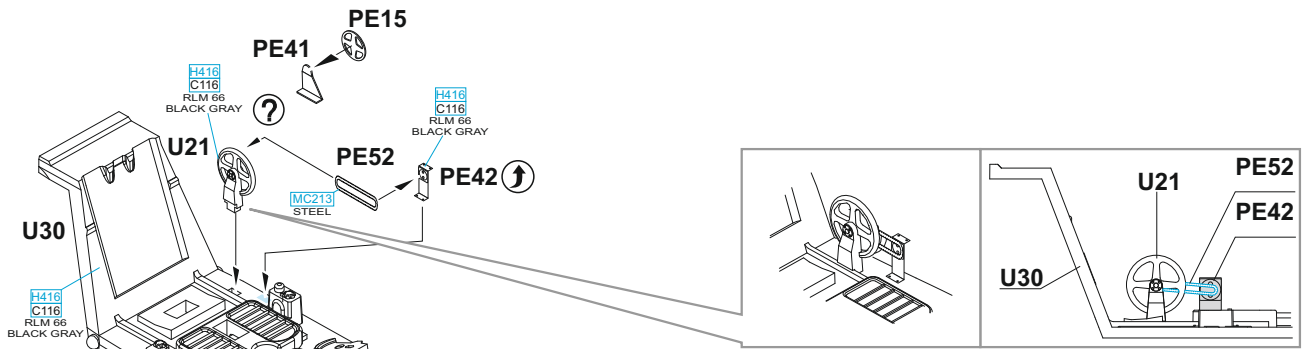

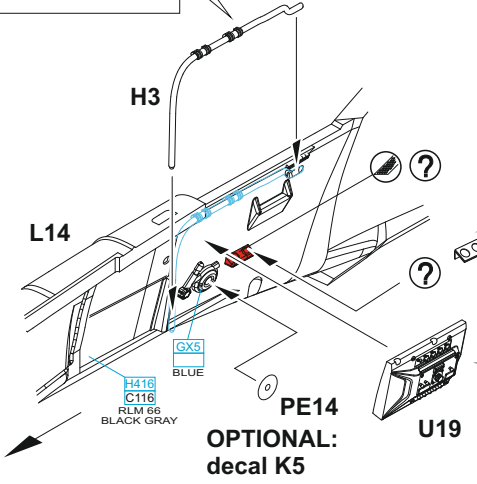
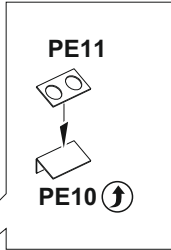
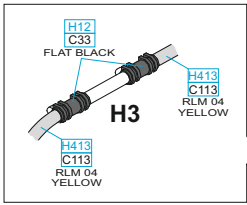

OPTIONAL:
decal K6

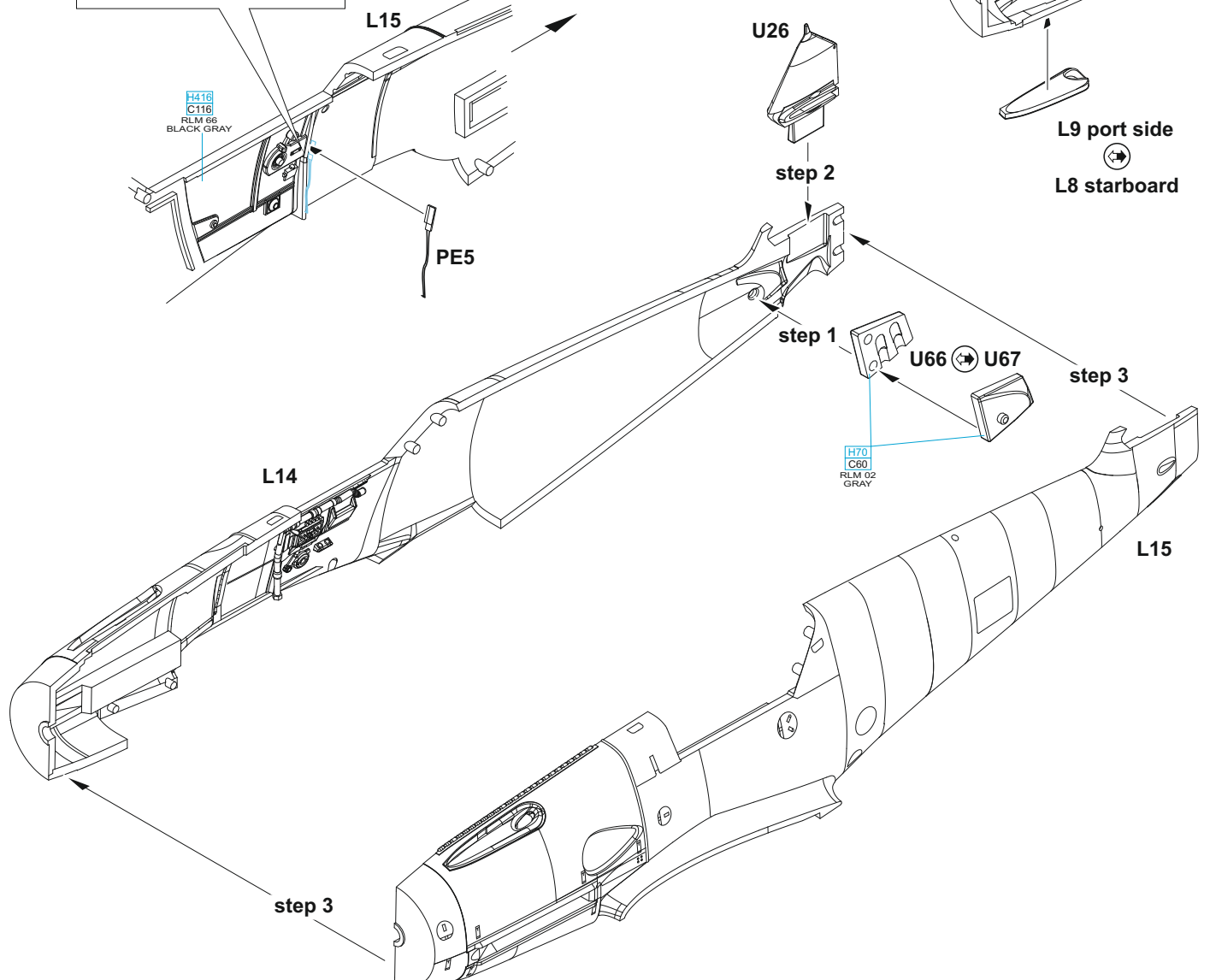
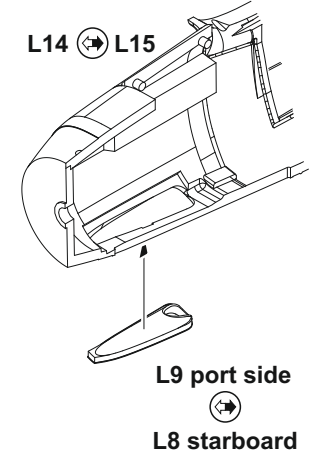
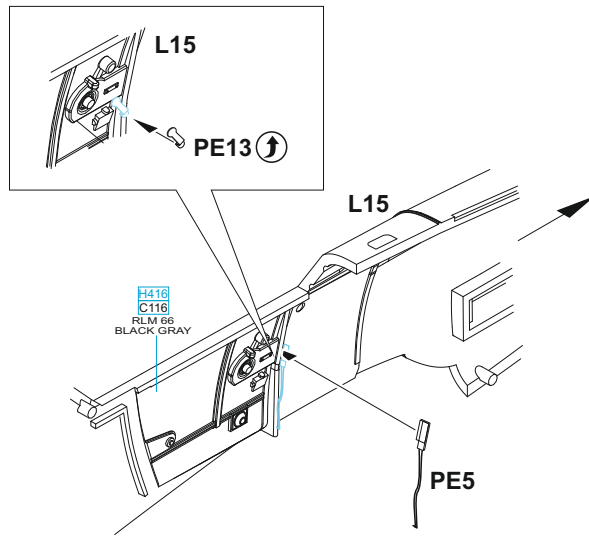
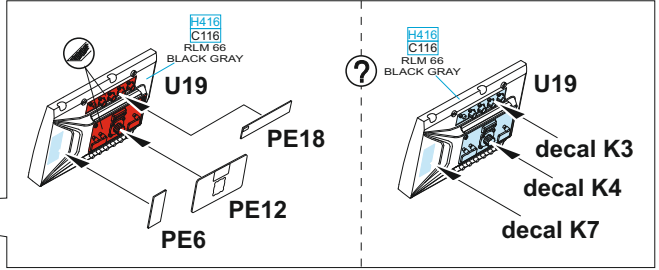

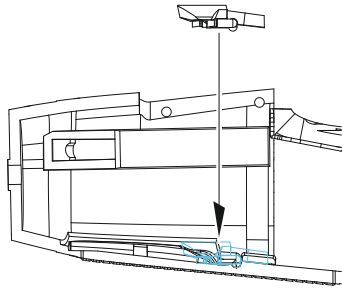
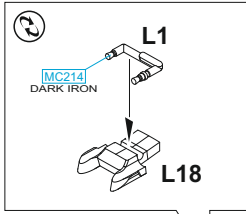

∅ - 0,2 mm

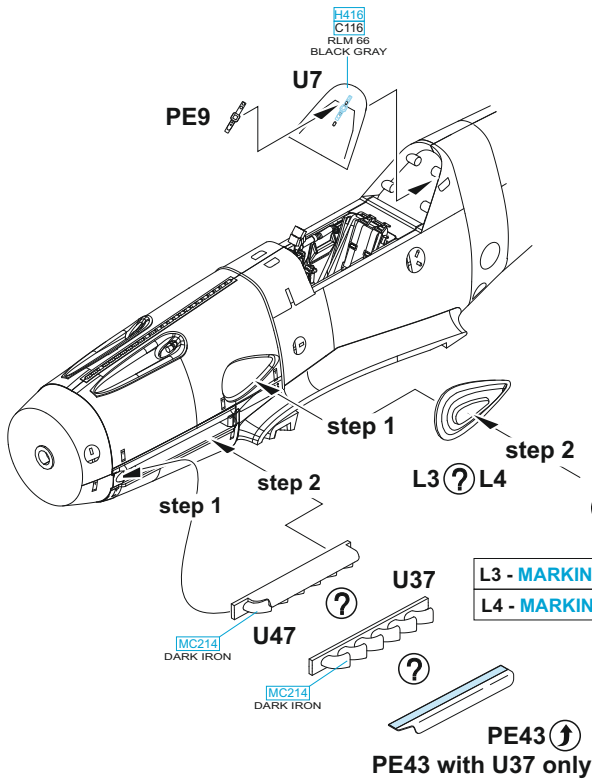
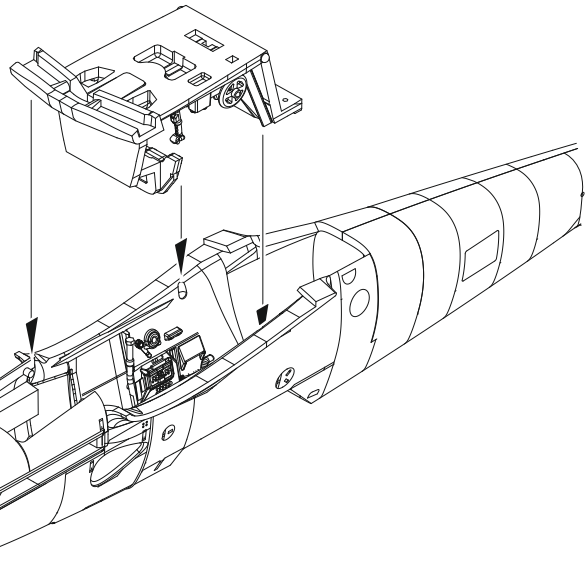

MARKING A

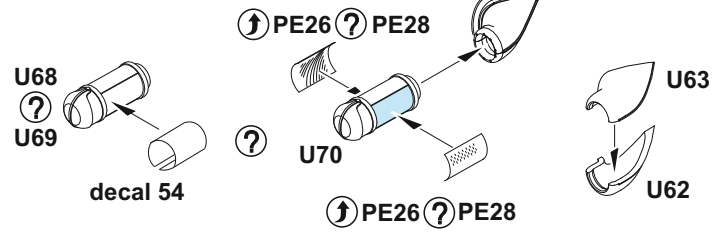

MARKINGS B, C, E, F

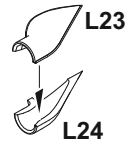

MARKING D

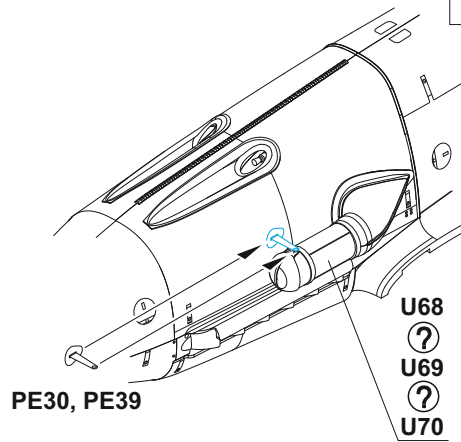
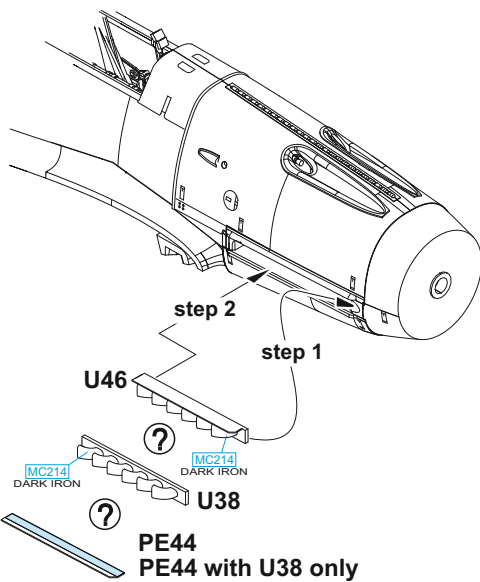
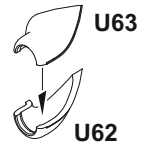

PE30, PE40

U68 **U69** **U70**

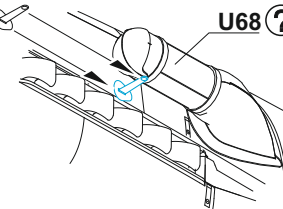

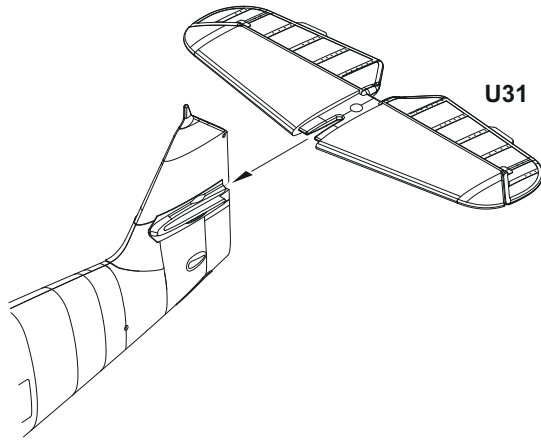

PE31 - MARKINGS **A, B, D, E** ONLY

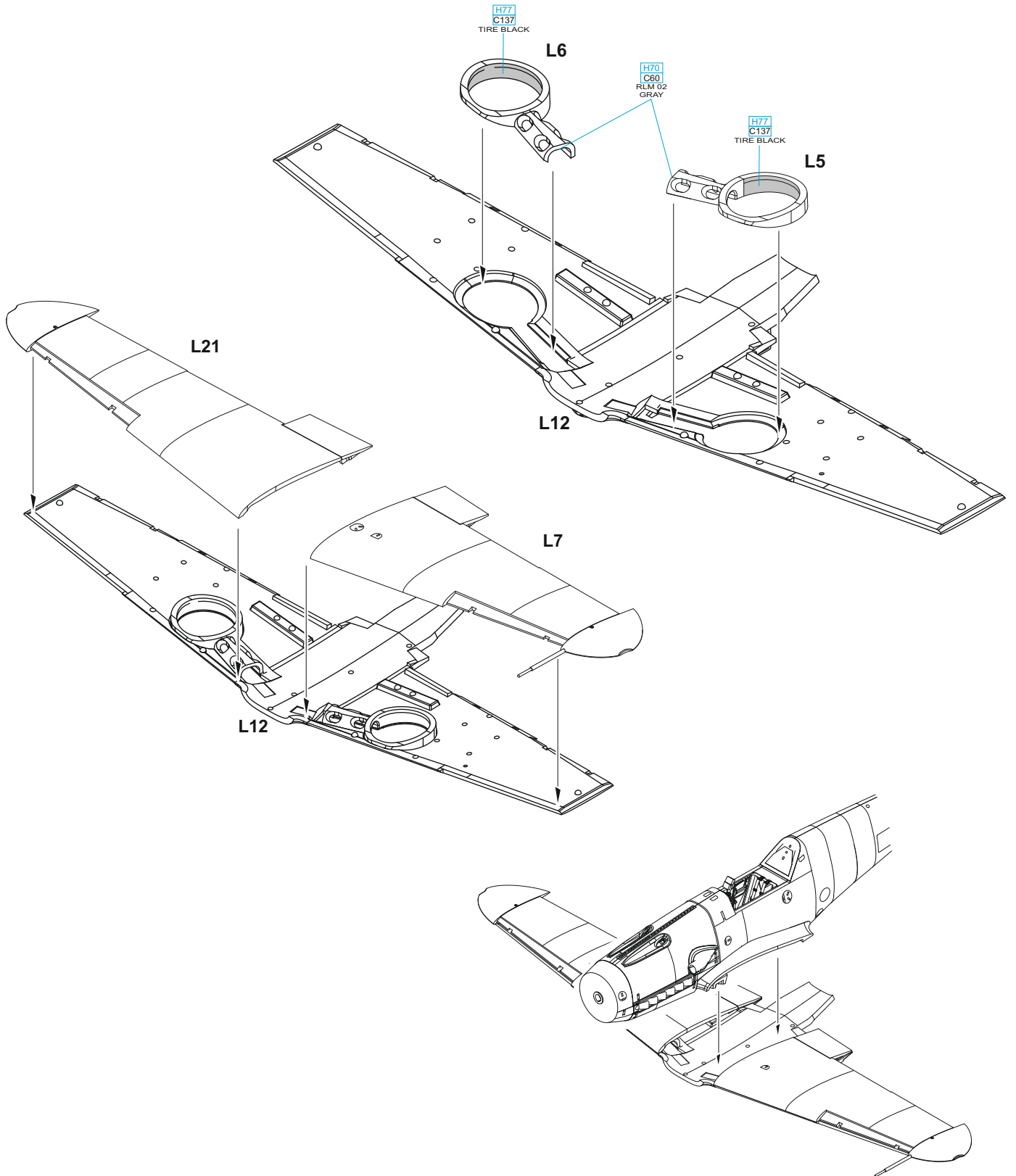
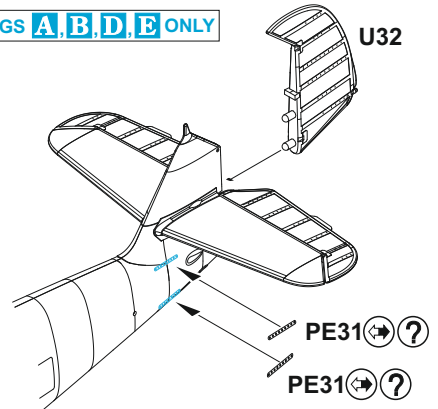

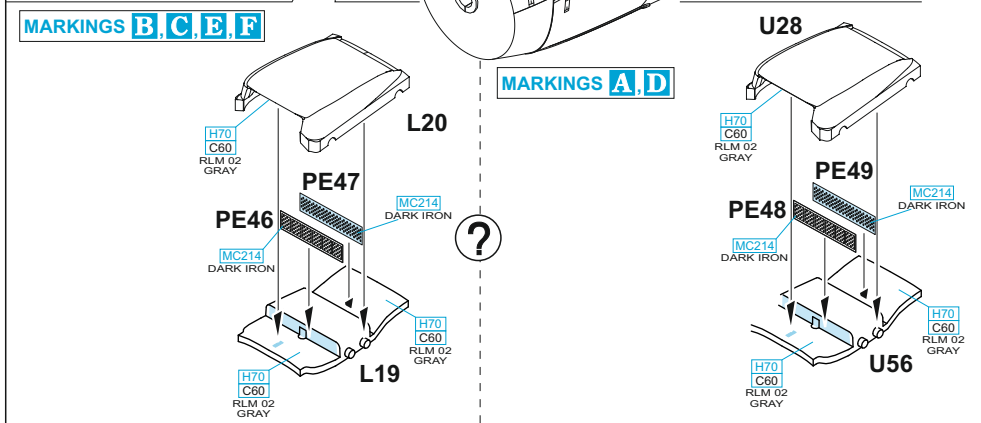
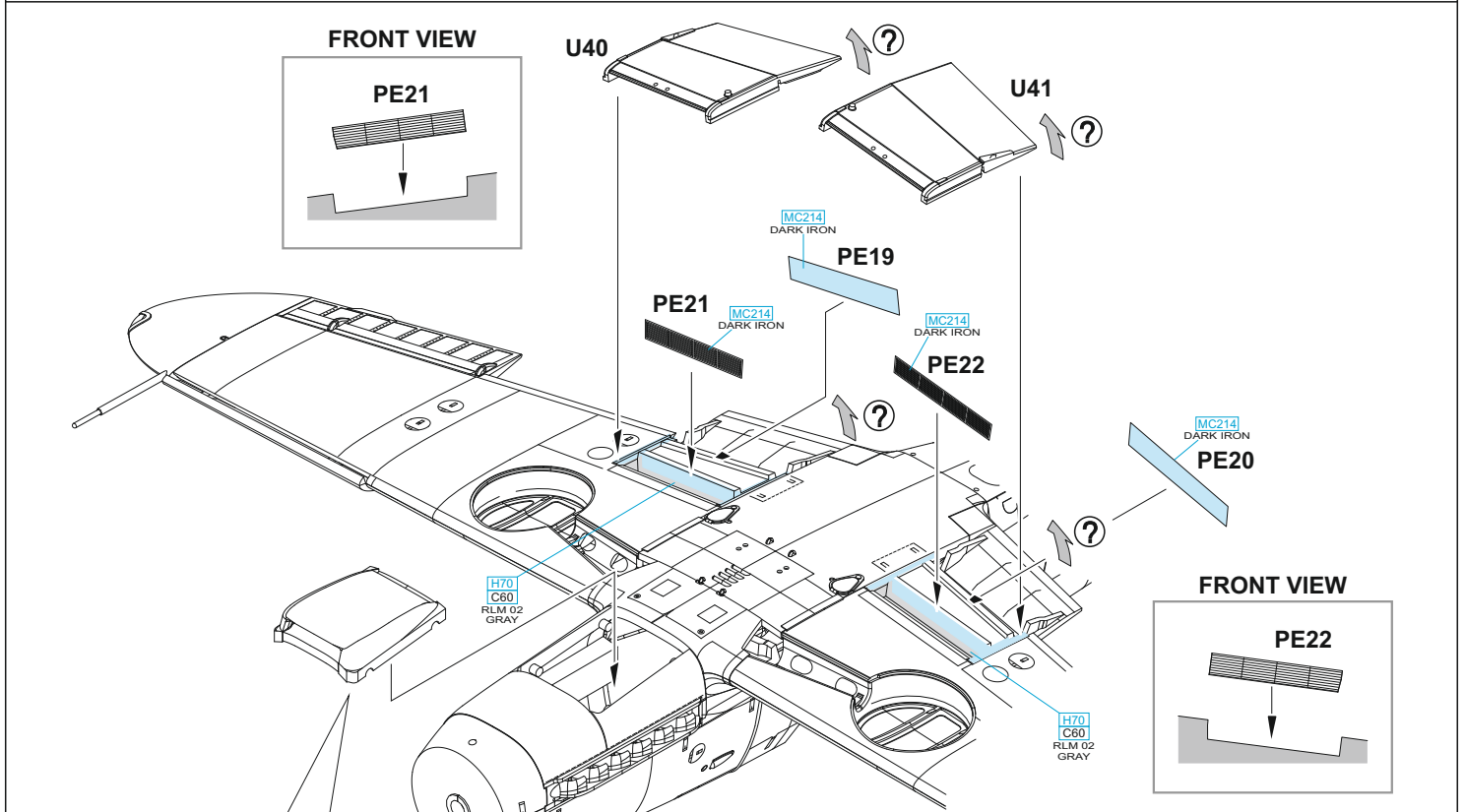
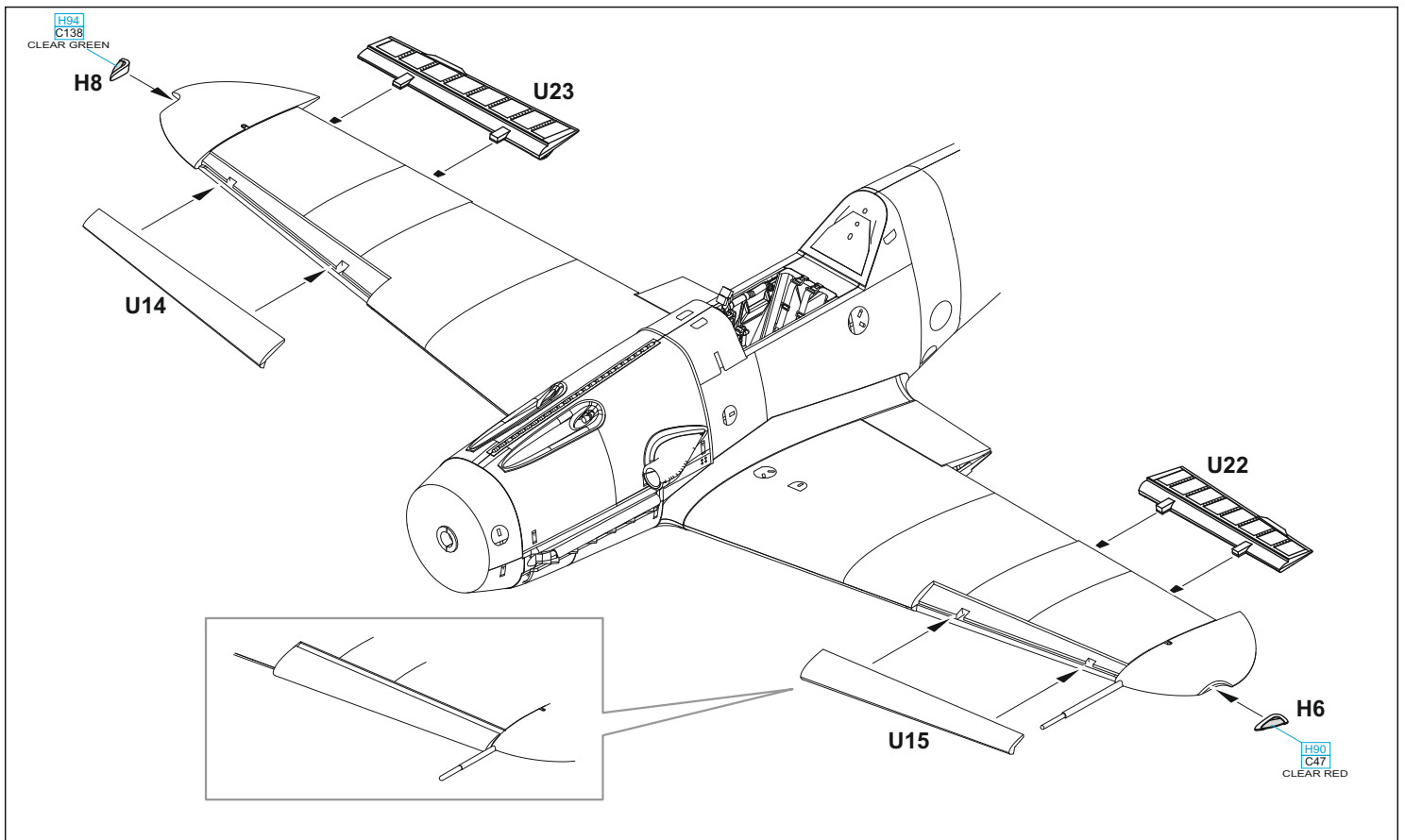

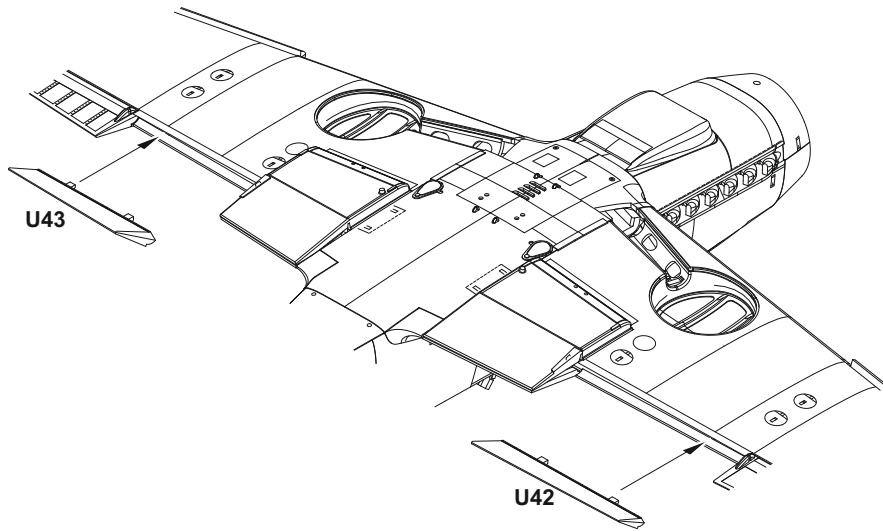

U45 - MARKINGS A, B, D, E, F ONLY

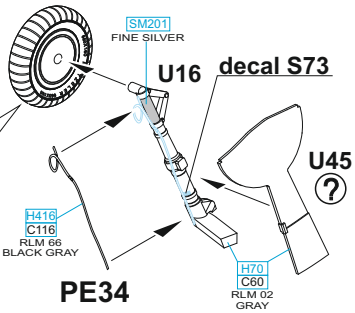
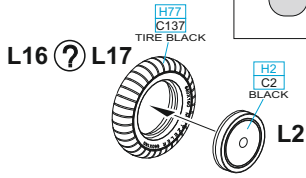

U44 - MARKINGS A, B, D, E, F ONLY

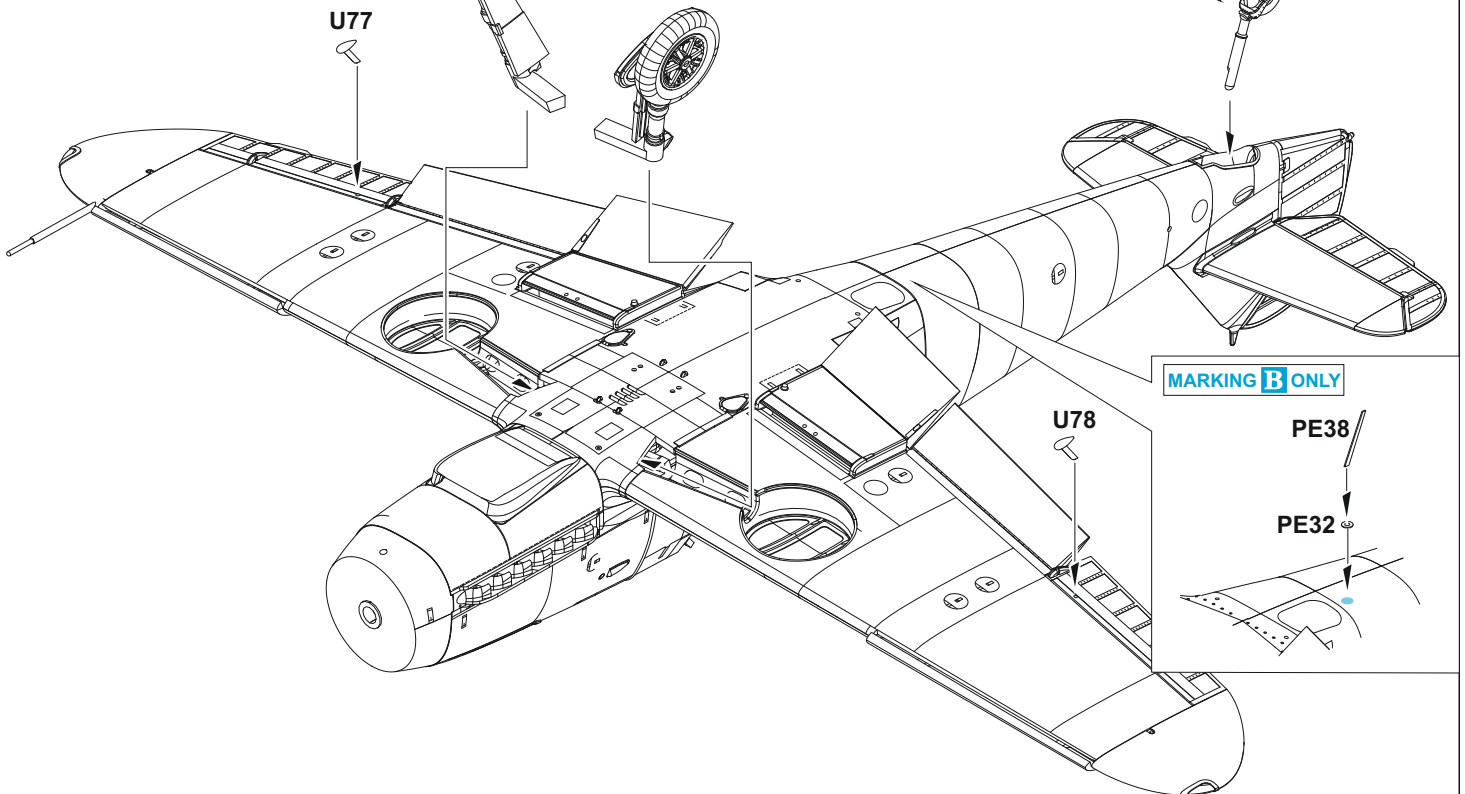
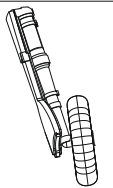
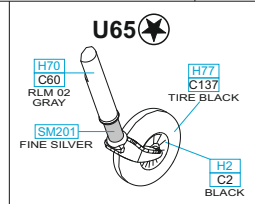
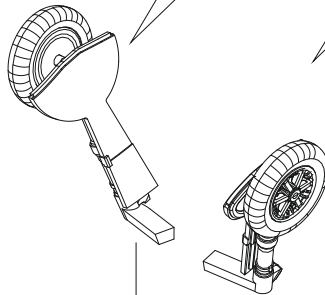
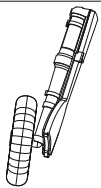
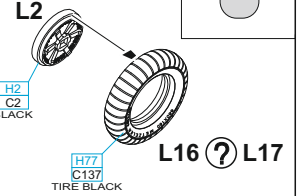
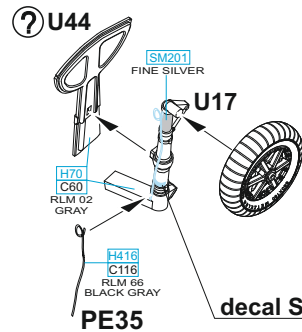

MARKING B ONLY

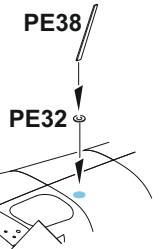

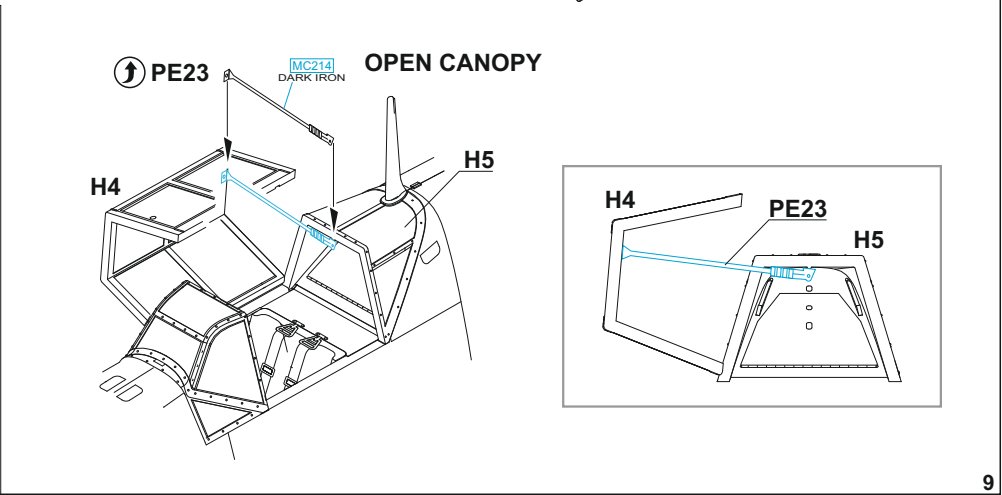
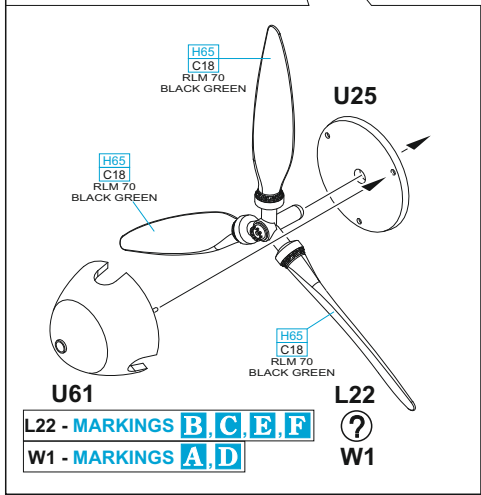
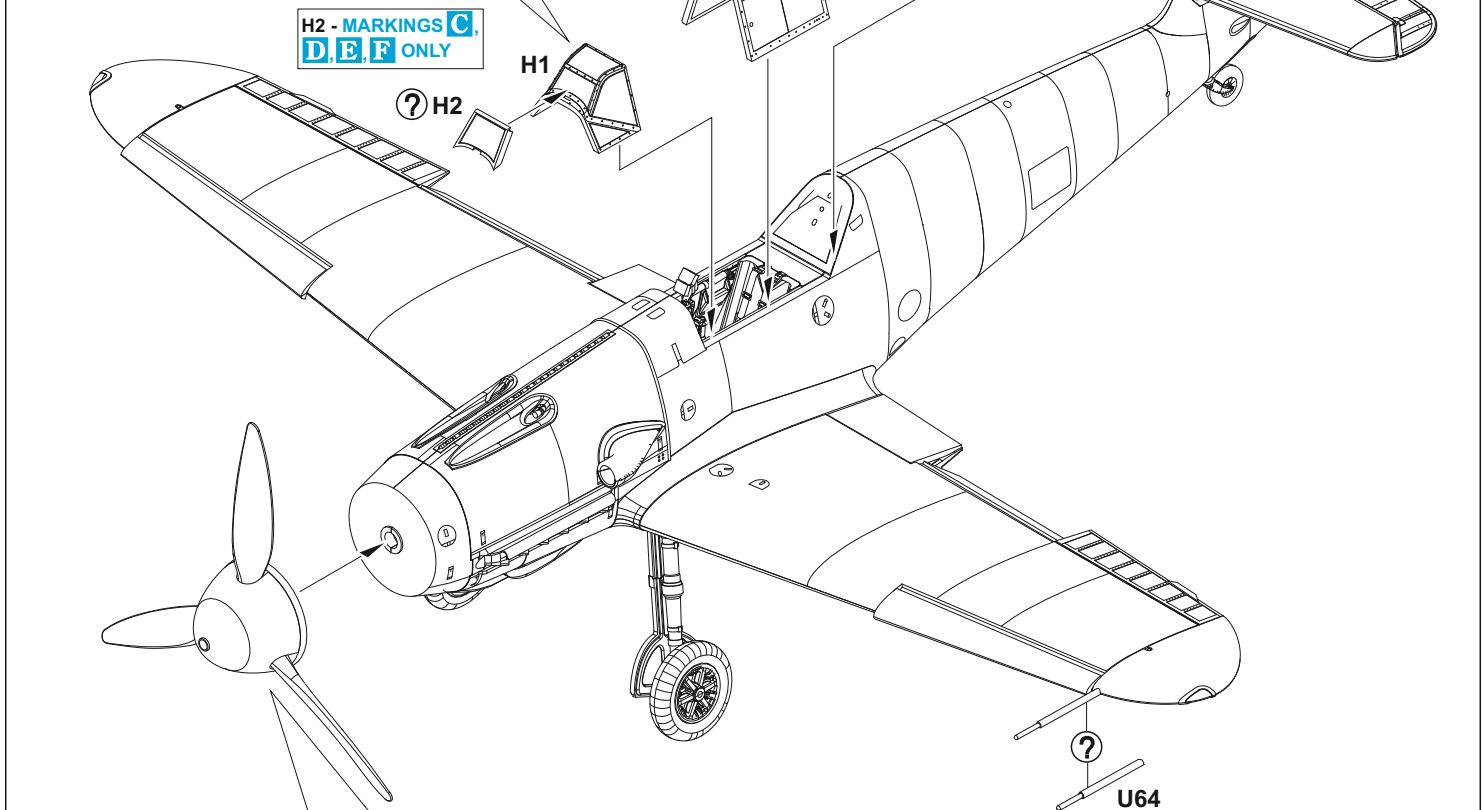
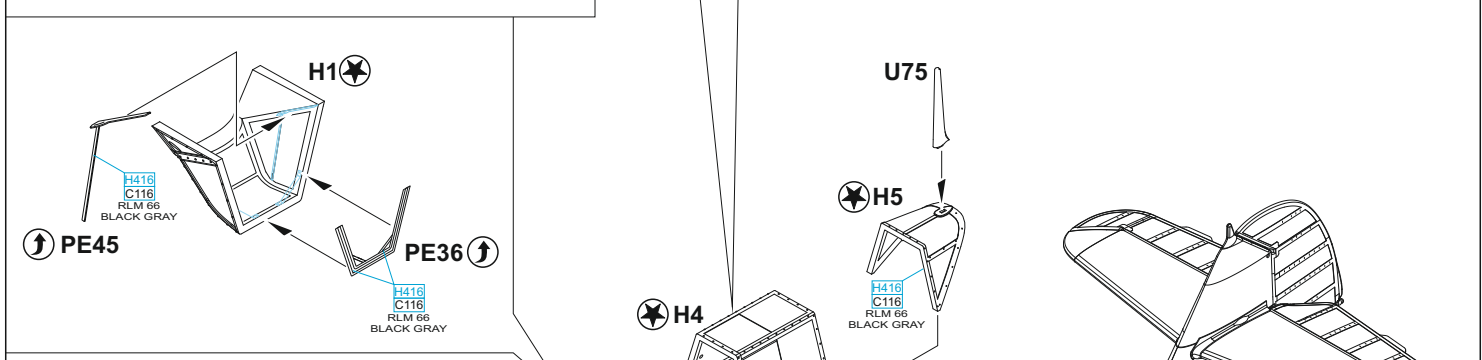
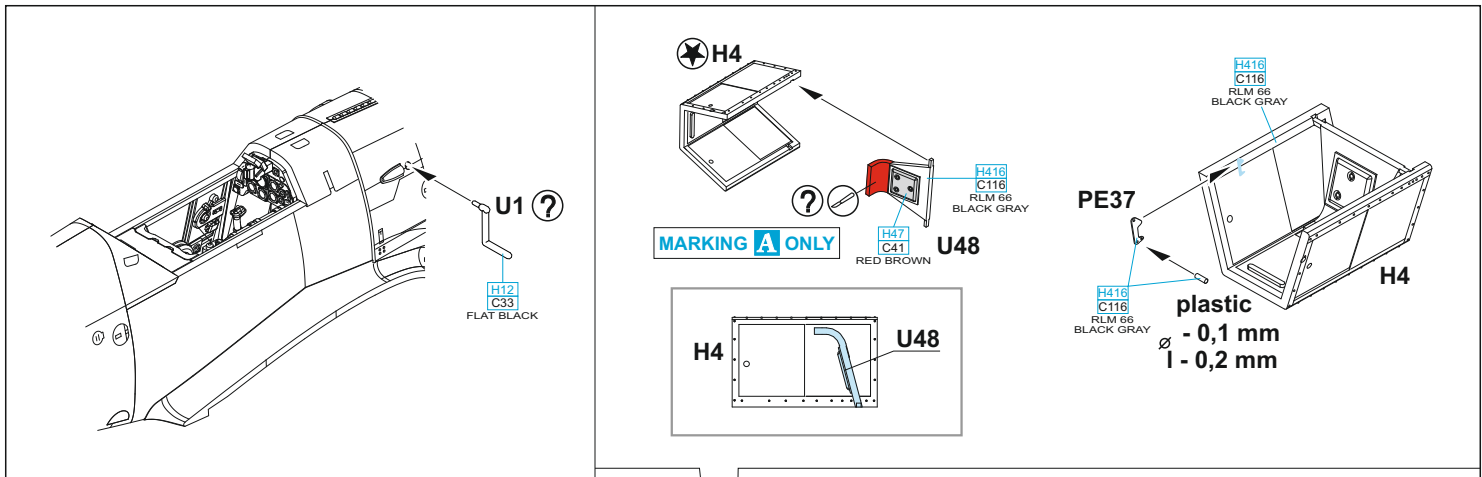

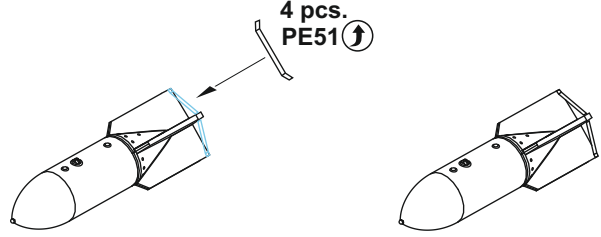
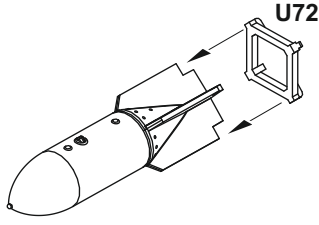
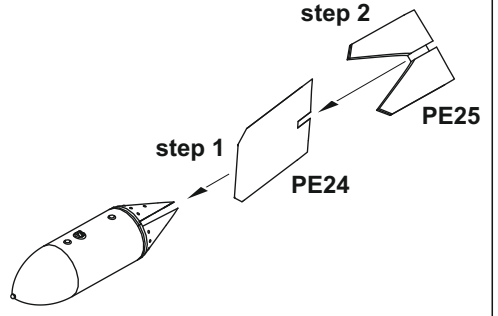
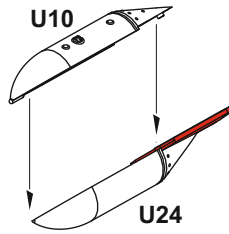
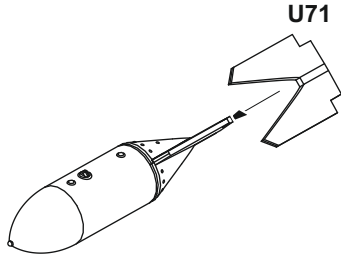
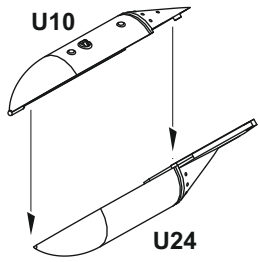

MARKING E ONLY

- H12 C33 FLAT BLACK ?
- H51 C11 GRAY ?
- H70 C60 RLM 02 GRAY ?
- H80 C54 KHAKI GREEN ?

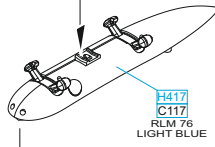
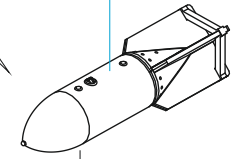
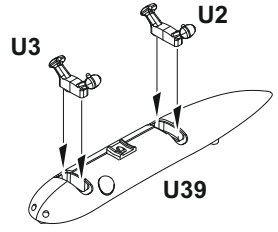

H1 C1 WHITE

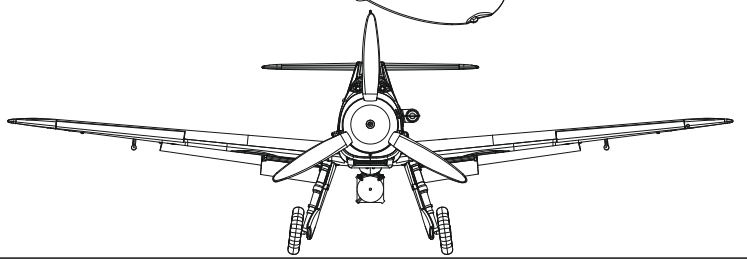
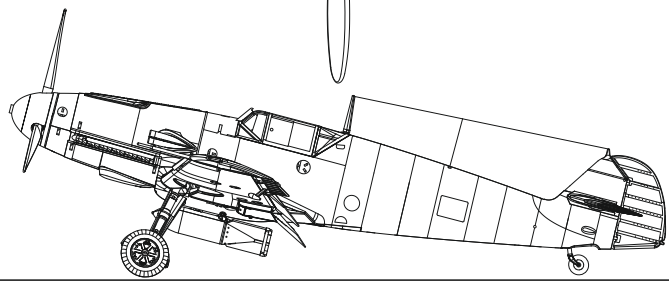
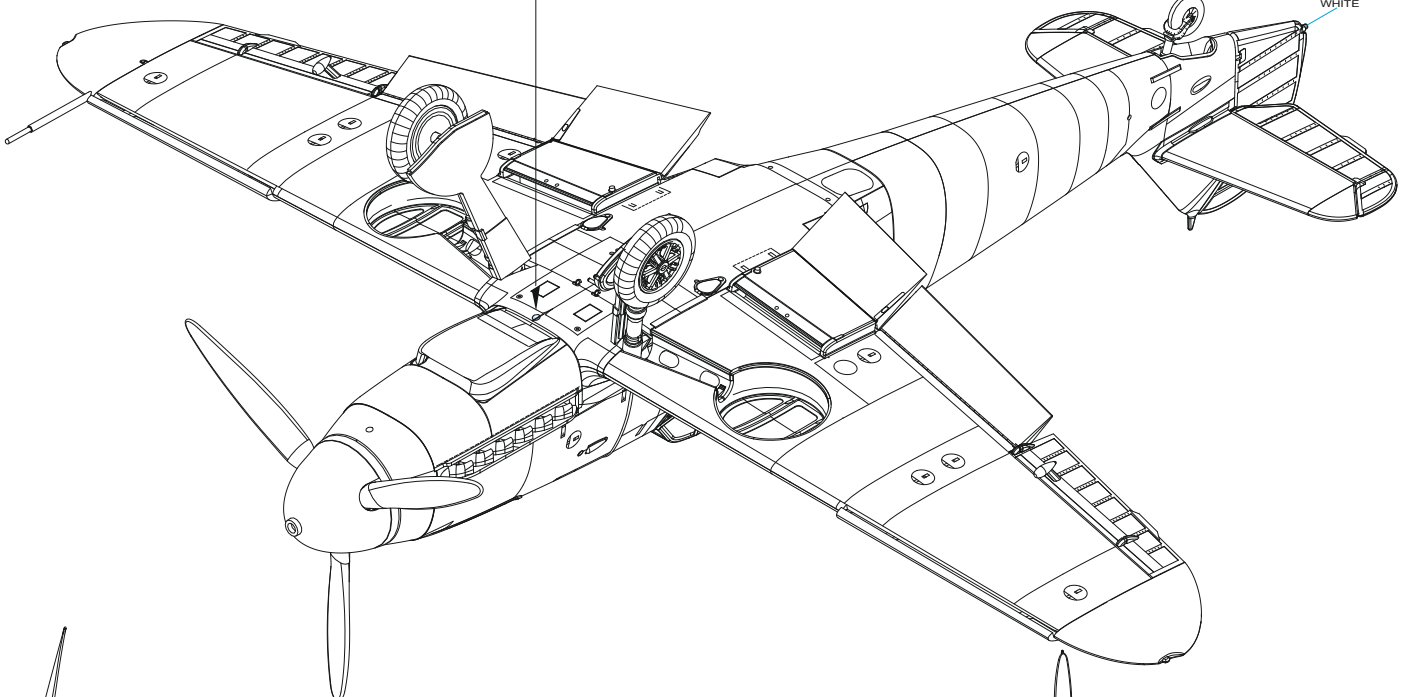

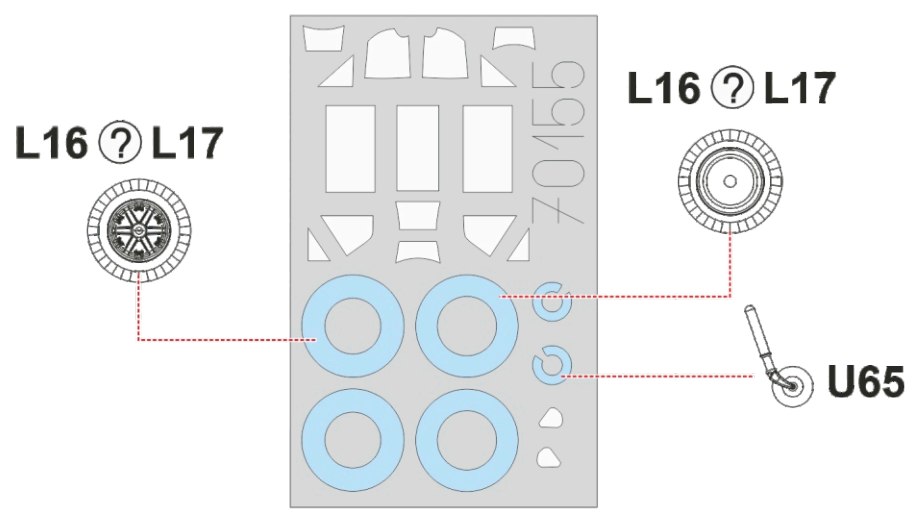
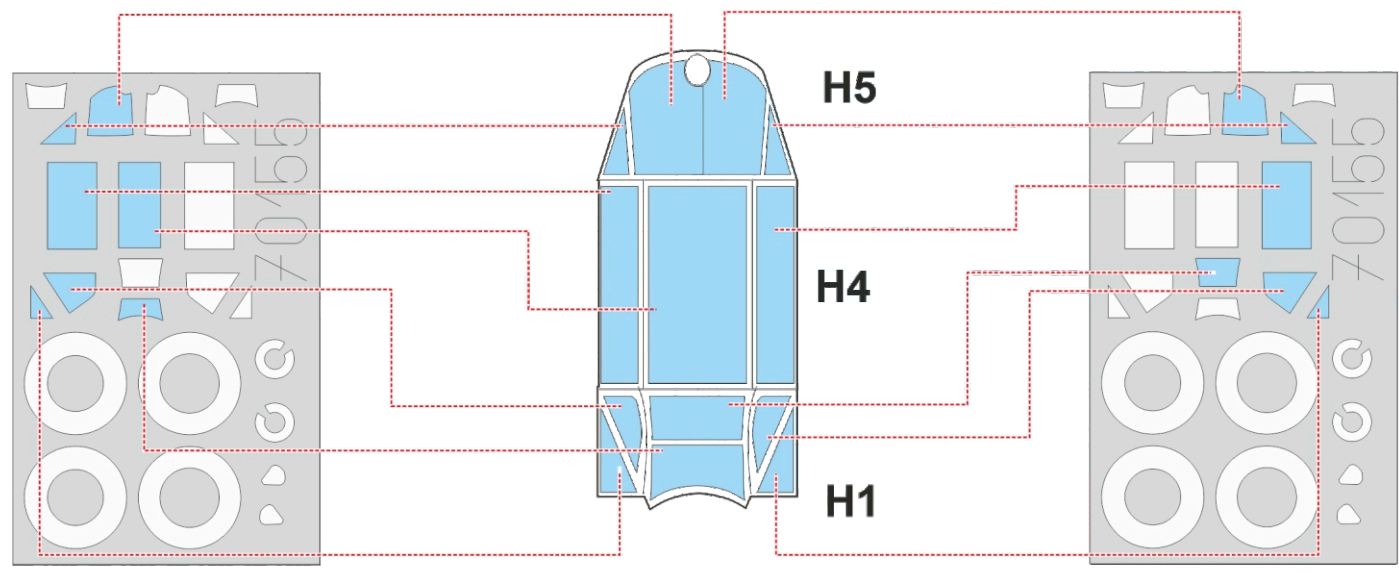
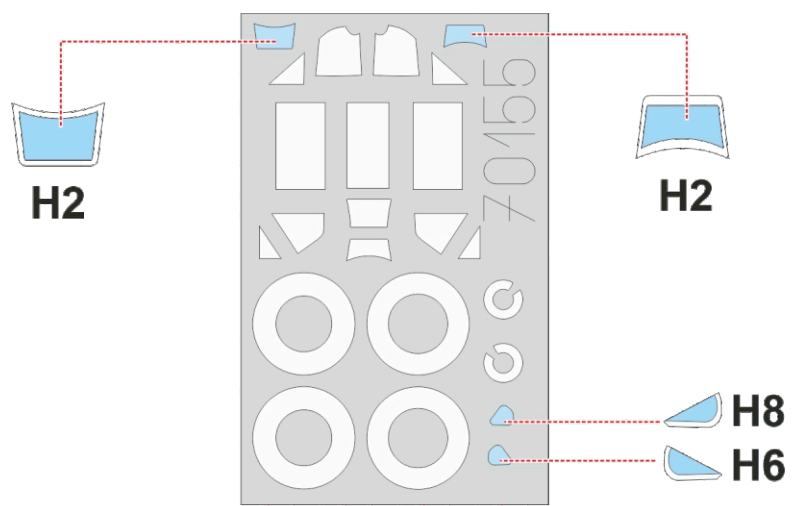

A Bf 109F-4/Trop, WNr. 10137, Oblt. Hans-Joachim Marseille, CO of 3./JG 27, Ain-el-Gazala, Libya, June 1942

Hans-Joachim "Jochen" Marseille became the most successful German fighter pilot fighting against the Western Allies. He was awarded the Knight's Cross with Oak Leaves, Swords and Diamonds. As an excellent pilot, and master of gunfire and dogfighting, he also showed a respect and grace to his opponents as he tried to save downed enemy airmen in the desert by dropping news of their fate on the other side of the front. On September 30, 1942, he flew the Messerschmitt Bf 109G-2/Trop as he led escort mission of the 3. Staffel to cover a squadron of Ju 87 Stukas. On the return leg, a smoke filled the cockpit and Marseille was forced to bail out. Hitting the rudder after the emergency exit of the plane, he lost consciousness, and his parachute did not open. Seconds later, Marseille died from the impact on the ground. The aircraft had the upper camouflage color RLM 79 sprayed all over the fuselage sides as a non-standard finish. The lower surfaces were sprayed with RLM 78 and the camouflage was complemented by the markings of the aircraft operating on the Southern front, i.e., white wingtips, white spinner and a band on the aft fuselage of the same color. The engine cowling bore the emblem of I. Gruppe JG 27 on both sides.

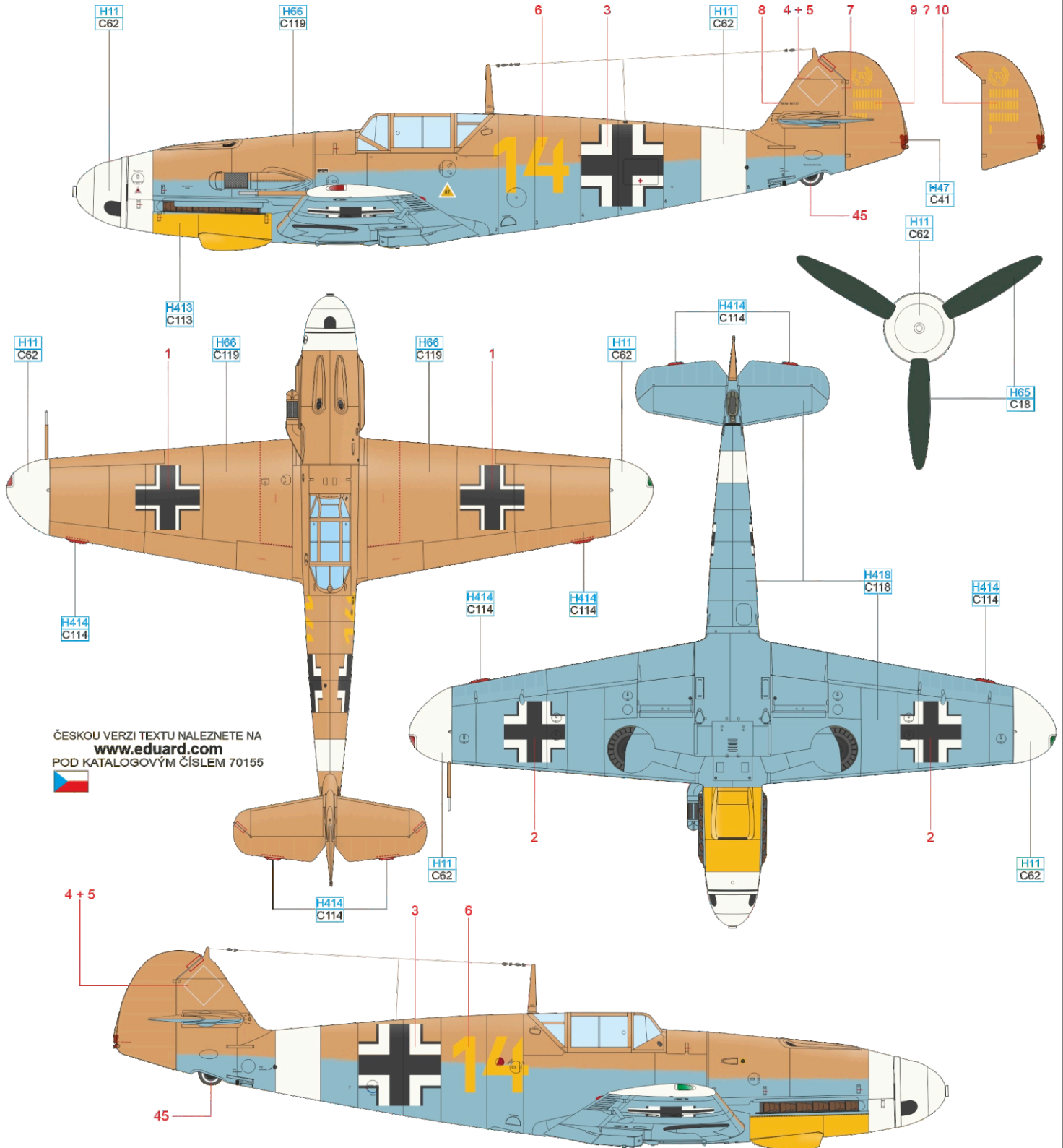

ČESKOU VERZI TEXTU NALEZNETE NA
www.eduard.com
 POD KATALOGOVÝM ČÍSLEM 70155



FLAT WHITE	H11 C62	RLM 78	H418 C118	RLM 79	H66 C119	RLM 23	H414 C114	RLM 04	H413 C113	RED BROWN	H47 C41	RLM 70	H65 C18
------------	---------	--------	-----------	--------	----------	--------	-----------	--------	-----------	-----------	---------	--------	---------

B Bf 109F-4, WNr. 7183, Hptm. Hans Hahn, III./JG 2, St. Pol, France, October 1941

Hans "Assi" Hahn, a fighter ace and recipient of the Knight's Cross with Oak Leaves was in command of 4./JG 2 from December 1939. From October 1940 he overtook the lead of III./JG 2. Fifty kill marks on the rudder of his aircraft represented his combat success on the Western Front. Hahn added the fiftieth kill to his tally on October 13, 1941, when he shot down a Spitfire near Boulogne-sur-Mer. Altogether he destroyed 66 enemy aircraft in the West. In late 1942 "Assi" Hahn moved to the East and commanded II./JG 54 from November 1, 1942. On February 21, 1943, he was downed, captured and spent seven years in captivity, returning back to Germany in 1950. He wrote a book about his life in prison "Ich spreche die Wahrheit" (I Speak the Truth). Hahn's total score stands at 108 kills. The rooster head painted on the fuselage was the crest of III./JG 2, based on Hahn's family name ("der Hahn" means "the rooster" in English).

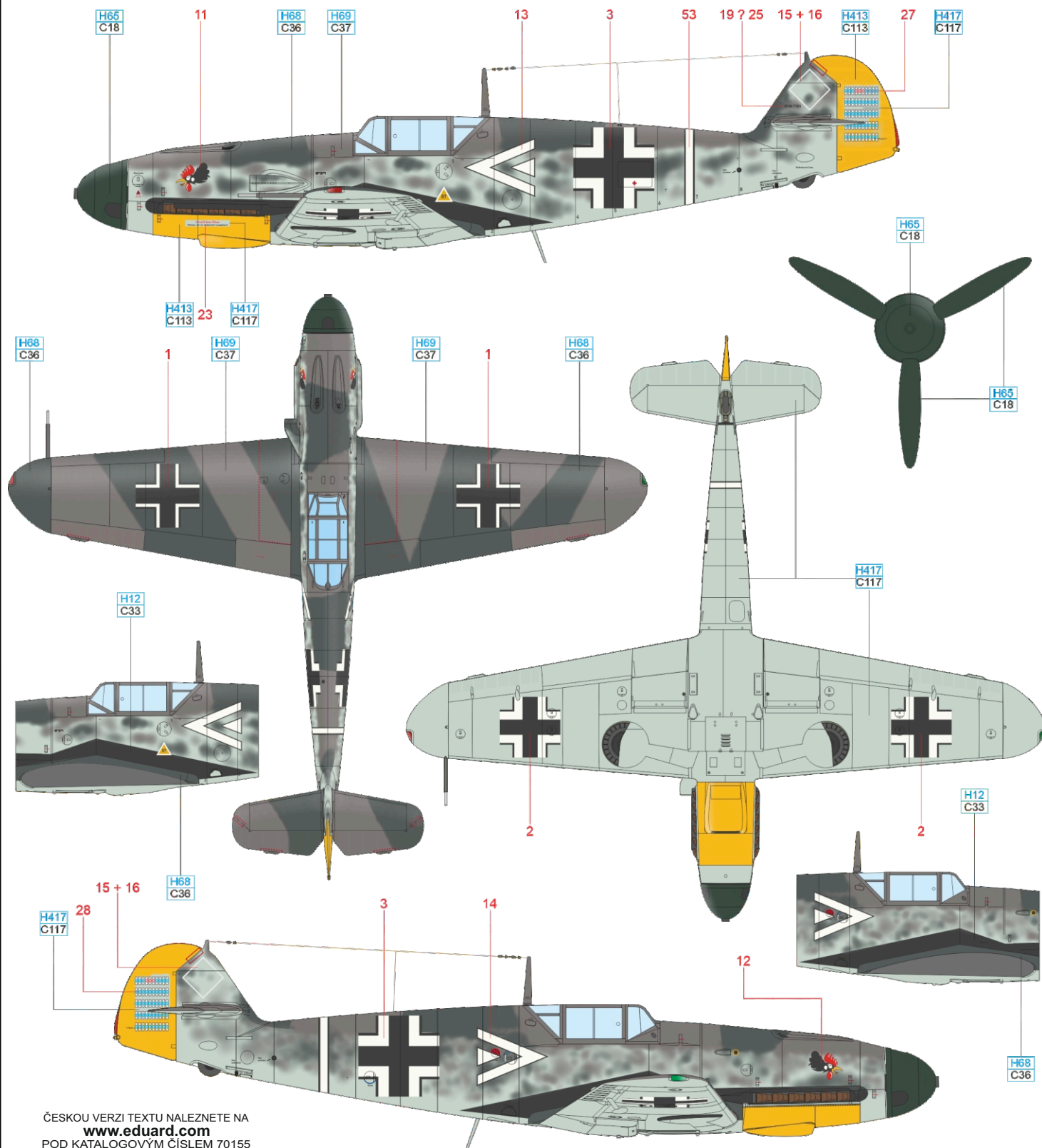

ČESKOU VERZI TEXTU NALEZNETE NA
www.eduard.com
 POD KATALOGOVÝM ČÍSLEM 70155

- RLM 76 H417
C117
- RLM 75 H69
C37
- RLM 74 H68
C36
- RLM 04 H413
C113
- RLM 70 H65
C18
- FLAT BLACK H12
C33

C Bf 109F-4, Maj. Hannes Trautloft, CO of JG 54, Relbitsy, the Soviet Union, March 1942

Hannes Trautloft entered combat in the Spanish Civil War. He flew the Bf 109 and participated in the development of tactics for this fighter aircraft. He fought in the Polish campaign as well as in France and managed to achieve at least one victory in every campaign. On August 25, 1940, he assumed command of JG 54. He led this fighter unit through Operation Barbarossa, the attack on the Soviet Union, and in subsequent combat till July 5, 1943. Trautloft was credited with 58 victories and he was awarded the Knight's Cross on July 27, 1941. His personal aircraft wore a non-standard camouflage scheme. It is not clear which colors were used by JG 54 during its deployment to the Soviet Union.

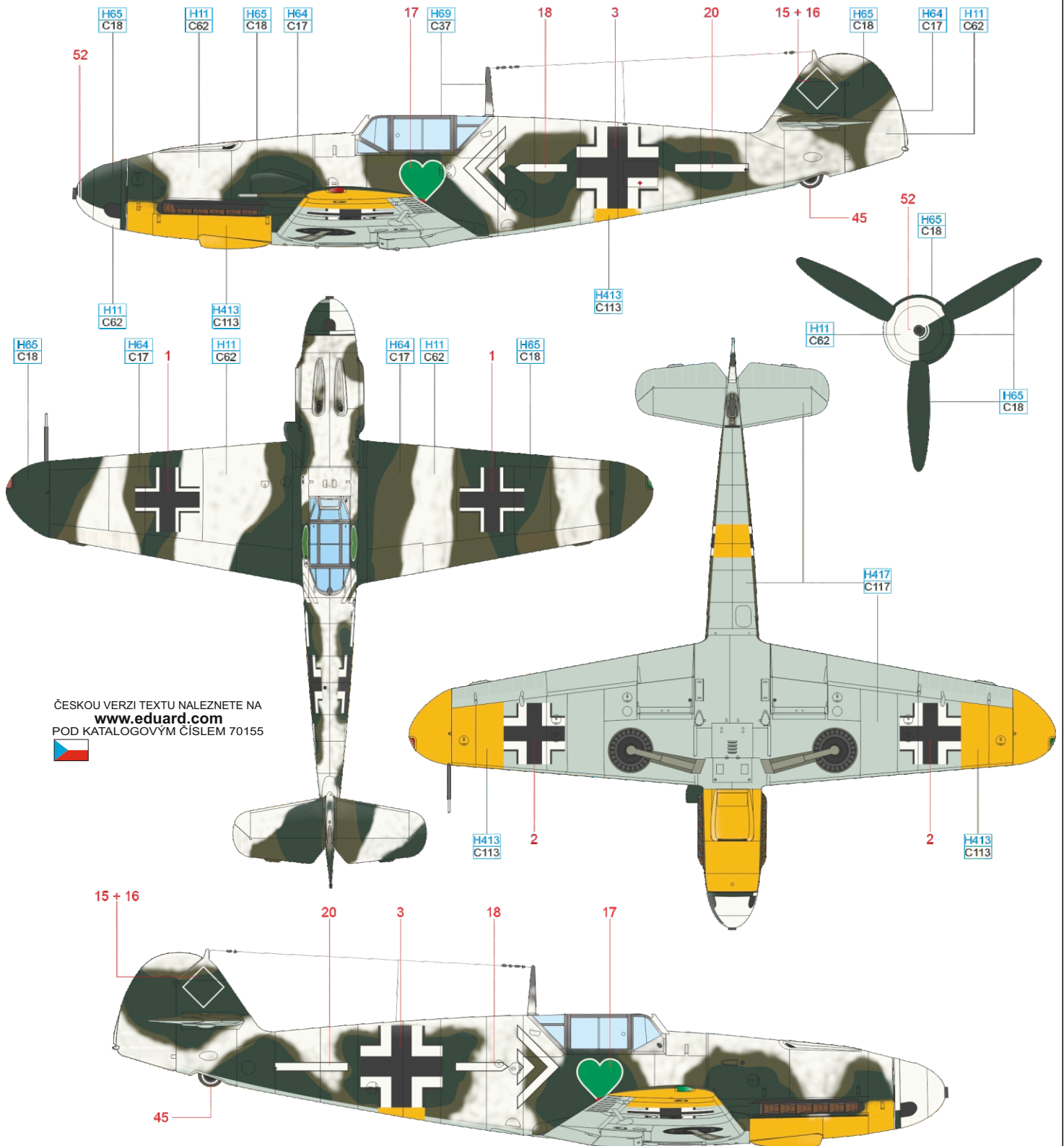

ČESKOU VERZI TEXTU NALEZNETE NA
www.eduard.com
 POD KATALOGOVÝM ČÍSLEM 70155



FLAT WHITE	H11 C62	RLM 04	H413 C113	RLM 76	H417 C117	RLM 75	H69 C37	RLM 71	H64 C17	RLM 70	H65 C18
------------	---------	--------	-----------	--------	-----------	--------	---------	--------	---------	--------	---------

D Bf 109F-4/Z, WNr. 13325, Oblt. Viktor Bauer, 9./JG 3, Shchigry, the Soviet Union, June 1942

This aircraft was flown by Viktor Bauer, the holder of the Knight's Cross with Oak Leaves and an ace with 106 kills. He achieved most of them in combat with Soviet pilots. Bauer flew this particular aircraft in the summer of 1942, when German Group of Armies A advanced on Stalingrad. The unit received Messerschmitts originally intended for service in North Africa, thus camouflaged in RLM 78/79 colors. The segments of RLM 74/70 (some sources state RLM 75/71) were added to the desert camouflage scheme to make the camouflage more effective in the Eastern Front environment. The yellow wingtips, fuselage band and lower cowling were typical for airplanes flown in the East Front. The name Ellen referred to Bauer's wife, the III./JG 3 emblem was painted on the nose of the aircraft. Bauer achieved his 106th and last kill on August 9, 1942, northwest of Stalingrad. The very next day he was hit by enemy fire, wounded, and had to belly-land his crippled plane. After rescue, Bauer served in various posts of Ergänzungs (replacement) units.

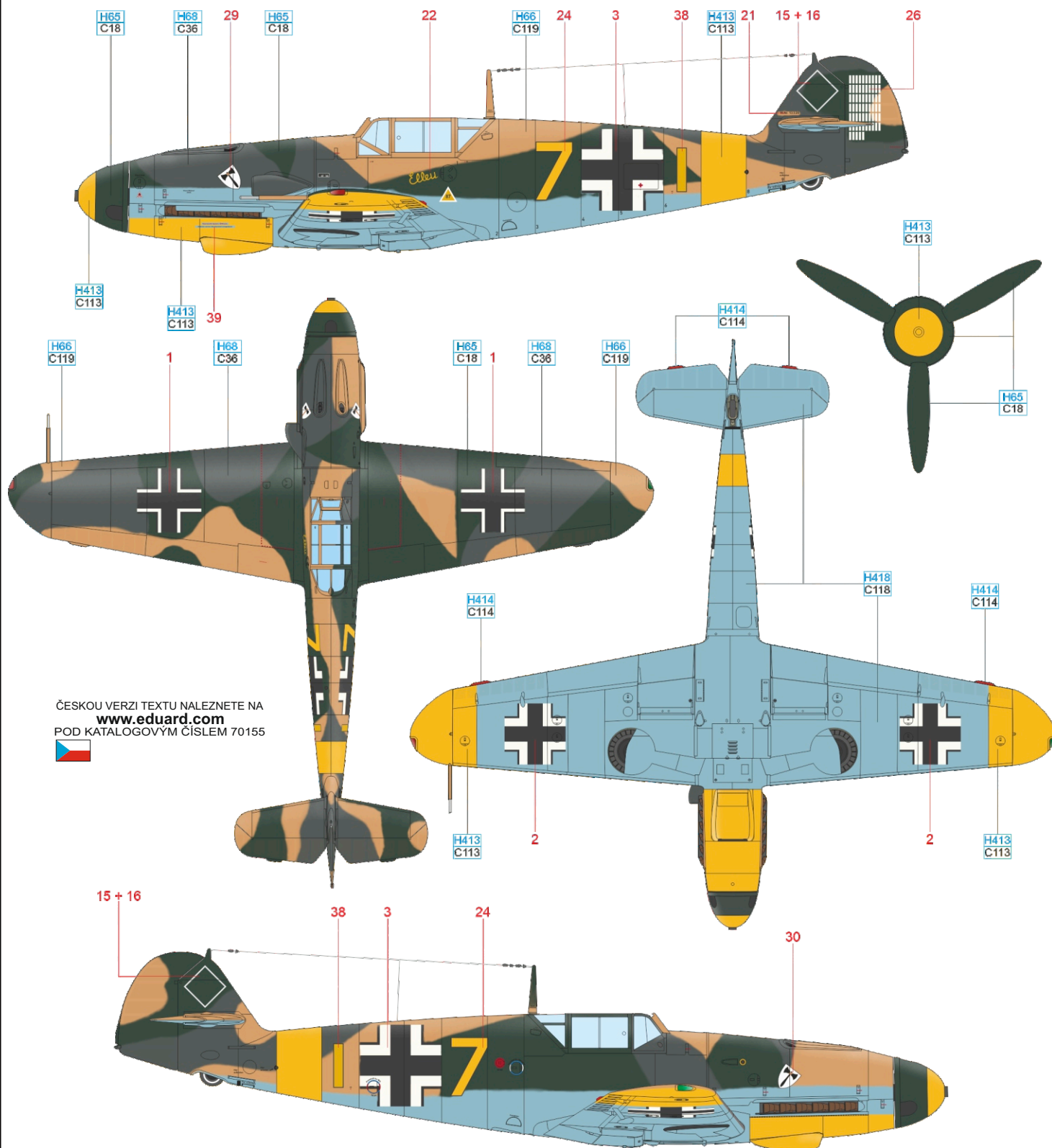

ČESKOU VERZI TEXTU NALEZNETE NA
www.eduard.com
 POD KATALOGOVÝM ČÍSLEM 70155



RLM 04	H413 C113	RLM 78	H418 C118	RLM 79	H66 C119	RLM 74	H68 C36	RLM 70	H65 C18	RLM 23	H414 C114
--------	--------------	--------	--------------	--------	-------------	--------	------------	--------	------------	--------	--------------

E Bf 109F-4/B, Oblt. Frank Liesendahl, 10.(Jabo)/JG 2, France, June 1942

During late 1941, the Luftwaffe considered renewing bombing of Great Britain and coastal shipping. Each fighter unit fighting against the Great Britain was ordered to single out one Staffel for this purpose. The 10. (Jabo) Staffel played this role within JG 2. Under command of Oblt. Frank Liesendahl pilots sank 20 vessels (total tonnage 630,000 BRT) over a four-month period. Liesendahl was killed when attacking cargo vessels near Brixham on July 17, 1942. Posthumously he was promoted to Hauptmann rank and was awarded the Knight's Cross as well. Liesendahl's personal mount wore a standard day fighter camouflage consisting of RLM 74/75/76. The ship-munching fox was a 10. (Jabo) Staffel badge. Note the symbols of vessels damaged or sunk by Liesendahl on the rudder.

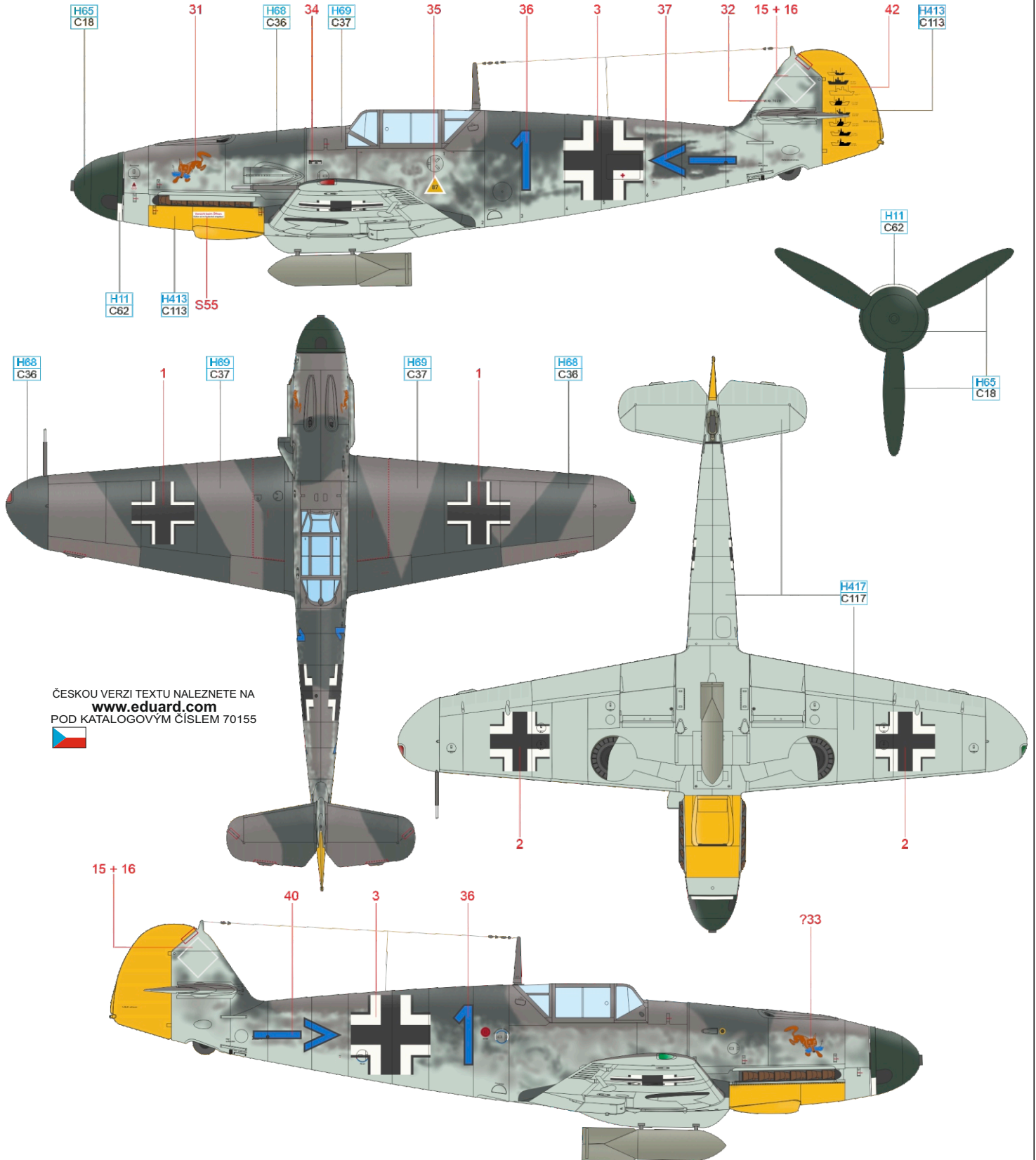

ČESKOU VERZI TEXTU NALEZNETE NA
www.eduard.com
 POD KATALOGOVÝM ČÍSLEM 70155



FLAT WHITE	H11 C62
RLM 76	H417 C117
RLM 75	H69 C37
RLM 74	H68 C36
RLM 04	H413 C113
RLM 70	H65 C18

F Bf 109F-4, WNr. 13169, Fw. Heinrich Bartels, 8./JG 5, Petsamo, Finland, September 1942

The Austrian Heinrich Bartels, a German ace with 99 kills achieved during some 500 combat sorties and holder of the Knight's Cross served on all fronts the Luftwaffe units were engaged. Half of his kills were gained in the north while with JG 5 against Soviet pilots. He met his fate on December 23, 1944, against P-47s of the USAAF's 56th FG in the Battle for the Ardennes. The wreck of his aircraft was discovered in 1968 near the town of Bad Godesberg in Germany. He flew this aircraft in the second half of 1942 during fighting in northern Finland. The aircraft was camouflaged in RLM 75/71/76 in a non-standard style dictated by operational conditions. In September 1942, the rudder displayed 29 kill marks, corresponding to his score. After Bartels was awarded the Knight's Cross and after reaching 45th victory, his crew chief painted the award on the rudder of the airplane.

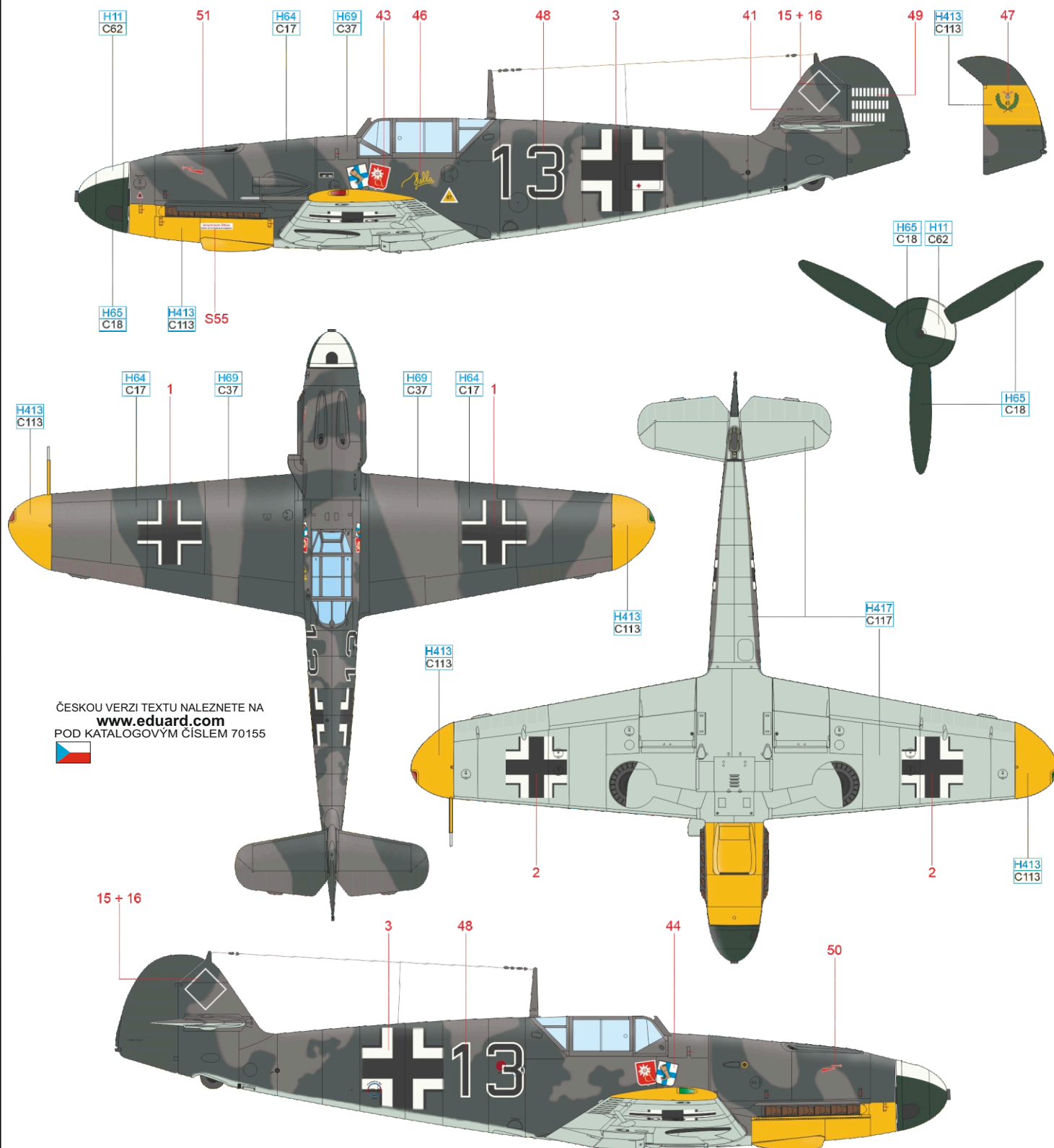

ČESKOU VERZI TEXTU NALEZNETE NA
www.eduard.com
 POD KATALOGOVÝM ČÍSLEM 70155



FLAT WHITE	H11 C62	RLM 76	H417 C117	RLM 75	H69 C37	RLM 71	H64 C17	RLM 04	H413 C113	RLM 70	H65 C18
------------	------------	--------	--------------	--------	------------	--------	------------	--------	--------------	--------	------------

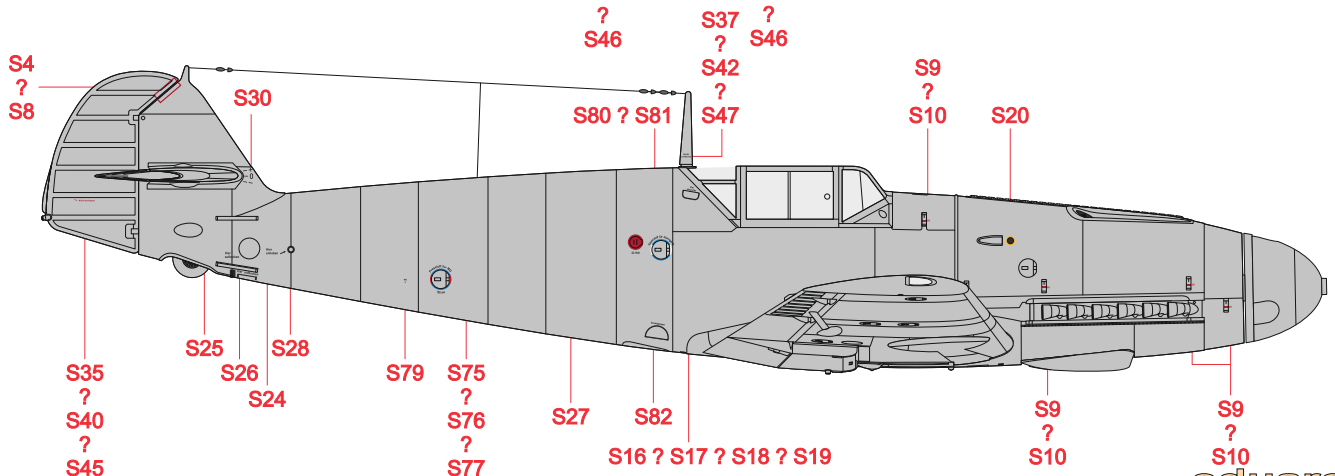
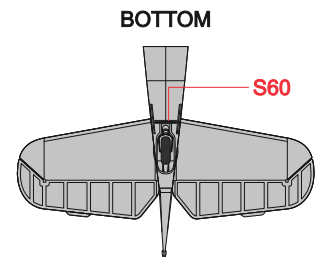
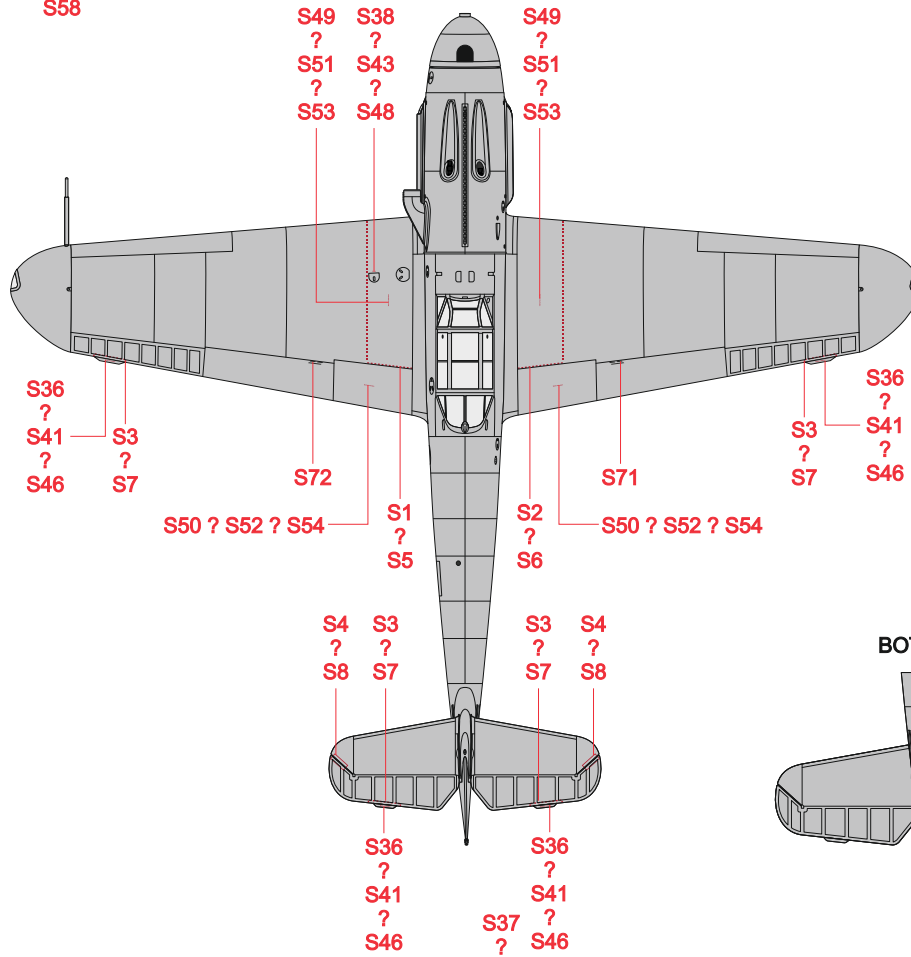
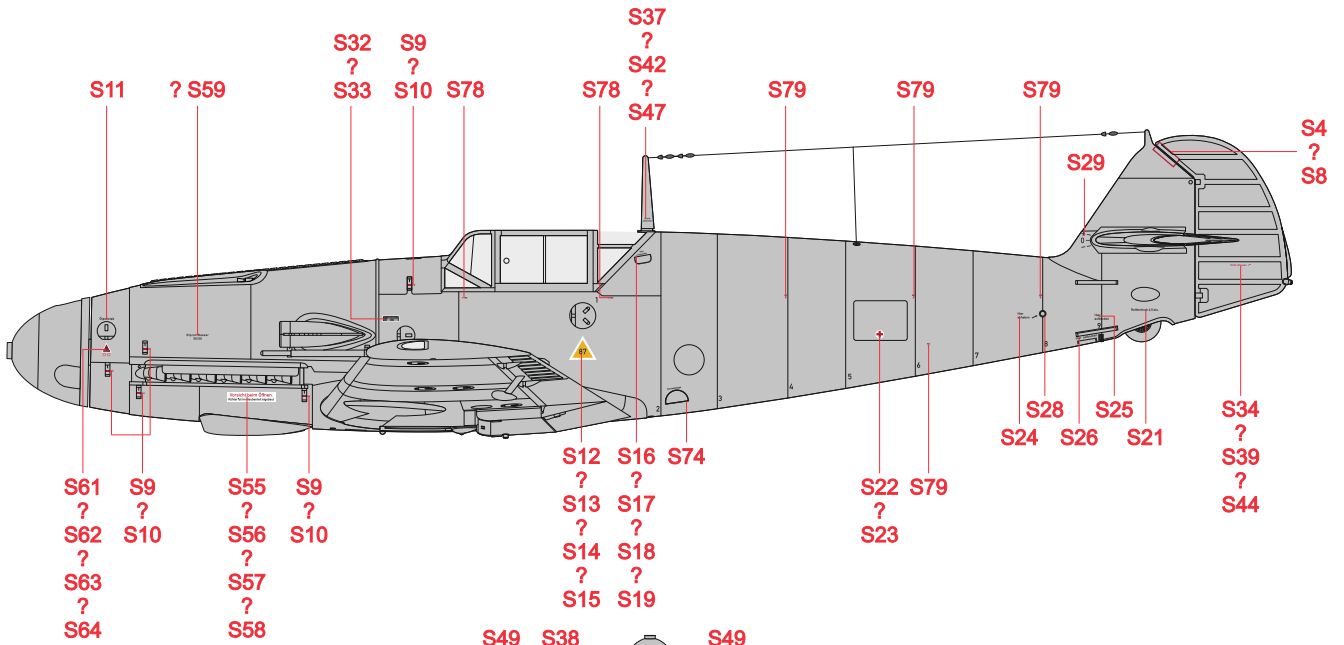

Eduard goodies for

Bf 109F-4 1/72

- 672313 Bf 109F propeller early PRINT (Brassin)
- 672314 Bf 109F propeller late PRINT (Brassin)
- 672315 Bf 109F gun barrels PRINT (Brassin)
- 672316 Bf 109F wheels PRINT (Brassin)
- 672317 Bf 109F undercarriage legs BRONZE (Brassin)
- 672318 Bf 109F radio compartment PRINT (Brassin)
- 672321 Bf 109F/G external fuel tanks (Brassin)
- 672322 Bf 109F wheel bays rounded PRINT (Brassin)
- 672323 Bf 109F/G wheels bays angular PRINT (Brassin)
- 672324 Bf 109 SC250 bomb (Brassin)
- 672325 Bf 109F/G exhaust stacks PRINT (Brassin)
- 672326 Bf 109F/G/K gun pods PRINT (Brassin)
- 672329 Bf 109 balance weights PRINT (Brassin)
- 3DL72018 Bf 109F SPACE (3D Decal Set)

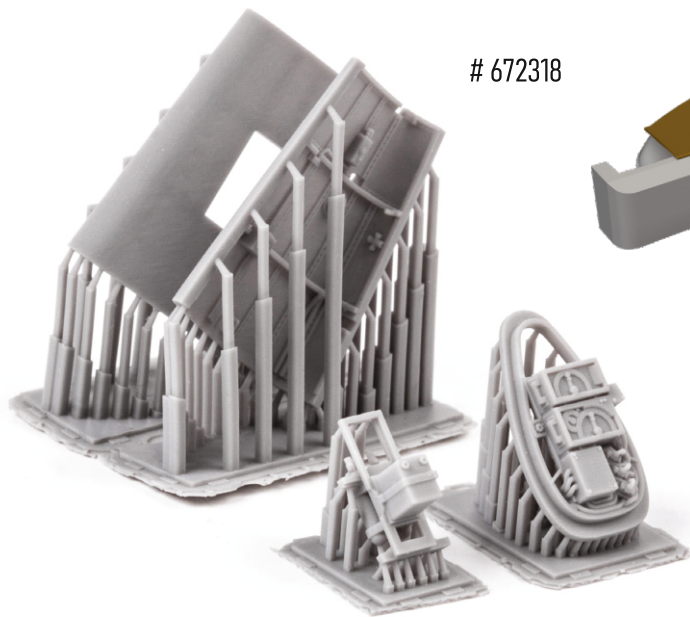
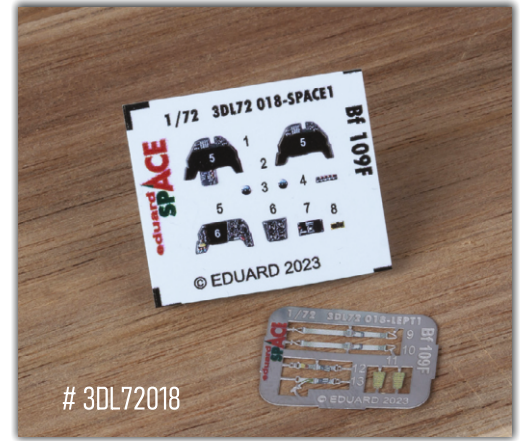

672318

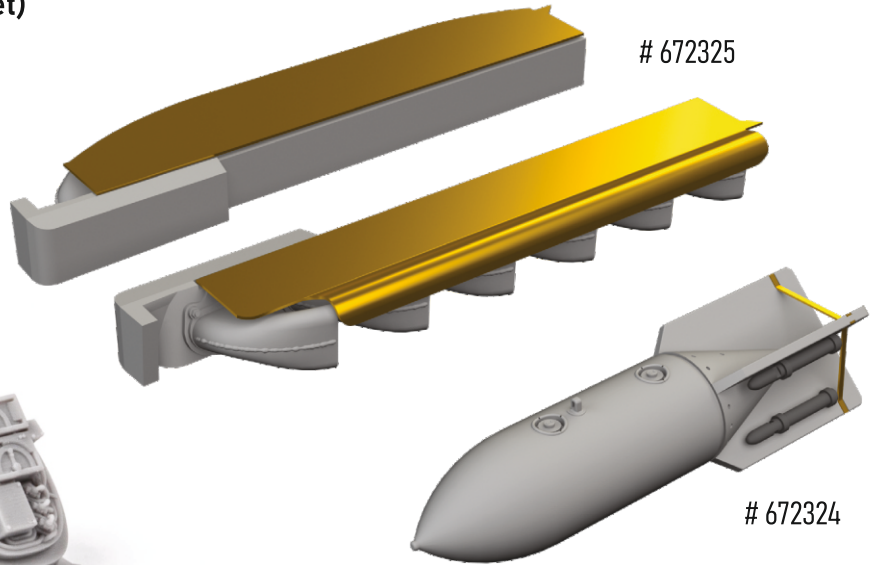

672325

672324

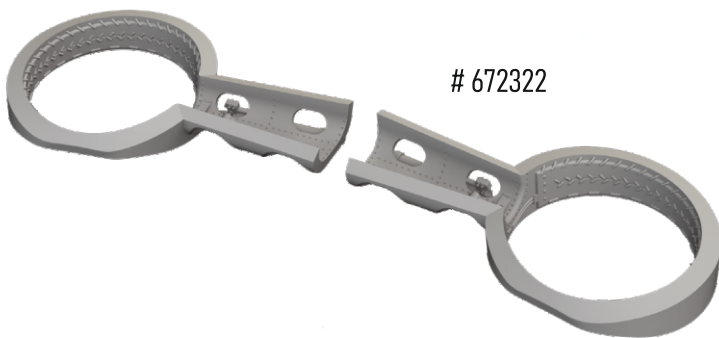

672322



672314

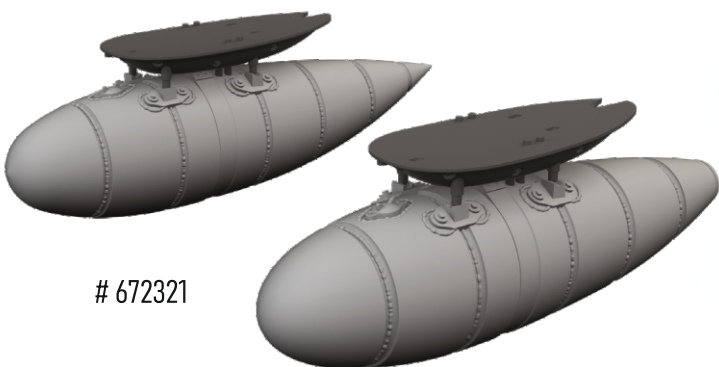

672321