

# Bf 109G-14

eduard

1/72 Scale Plastic Model Kit

**ProfiPACK**  
edition



item No. 70161

**No other aircraft is so intimately connected with rise and fall of the German Luftwaffe during the WWII like the Messerschmitt Bf 109. It became the true workhorse of the war...**

The evolution of this aircraft outlived the era in which it was conceptualized. The Bf 109s bore the brunt of Luftwaffe duties from the opening battles of Nazi Germany through to her final downfall.

#### As progressive as possible

The history of the aircraft begins during 1934-35, when the Reich Ministry of Aviation formulated a requirement for the development of a single-engined monoplane fighter. Proposals were submitted by Arado, Heinkel, Focke-Wulf and Bayerische Flugzeugwerke. The design bureau of the last-mentioned company was led by its technical director Willy Messerschmitt, who was riding a wave of popularity based on the success of his liaison aircraft, the Bf 108. Messerschmitt's goal was to conceive of an aircraft with the best possible performance for the specified weight, size, and aerodynamic qualities. Over the subsequent months, several prototypes were built that served first and foremost in development flights and further modifications. The aircraft was relatively small, and compared to the prevailing trends of the time, full of revolutionary features such as low wing design, retractable landing gear, wing with a thin airfoil, wing slats, landing flaps, weapons firing through the propeller hub, and so on. Even the enclosed cockpit and the method of the airframe design were not very common just four years prior to the beginning of the Second World War. At its conception, the Bf 109 was a very promising asset despite some powerplant troubles. These were solved by the introduction of the DB 601. This engine, together with its development DB 605 variant, is umbilically connected to the success of the Bf 109. These two-row, twelve-cylinder inverted V engines powered several tenths of thousands of 109s in over 25 versions and variants.

#### From Spanish War to the defence of the Reich

The first combat use of Bf 109 occurred during Spanish Civil War, where three developmental Bf 109s were deployed in December 1936. The main reason of revealing the modern fighter to the world was quite down-to-earth: To validate the aircraft's abilities in modern aerial combat. Shortly thereafter, production aircraft in the form of the Bf 109B-1 began to reach 2.J/88, the Legion Condor. The desire of Germany to demonstrate its aerial prowess to potential foes was advanced further in international sport meets. The triumphs attained in Zurich in the summer of 1937 were complemented several months later by grabbing the speed record of 610.95 kph. In very short order, the progressive developments represented by the C, D and E versions appeared. Despite this, the delivery of the types to combat units did not sustain a rate that was desired by military brass. Even by August 1938 the Bf 109 accounted for less than half of the 643 front line fighters in service. The later months saw an increase in these rates. By the time of the invasion of Poland (which saw the participation of only some little more than 200 aircraft) the Luftwaffe possessed the best fighter produced in continental Europe. With both a qualitative and quantitative advantage, the fighter wing of the Luftwaffe entered the Polish

campaign, the first defence of the Fatherland, Blitzkrieg against the West, and the Battle for France. With one foot in the door that was the English Channel, the Luftwaffe embarked on the attacks on Britain in the summer months of 1940. Here, the first weakness of the Bf 109 emerged: The inability to carry drop tanks that would have enabled the type to effectively escort bombers to England. This was one of the factors responsible for the defeat of the Luftwaffe in the Battle of Britain. Experiences gained in 1940 led to the development of the F version prior to the spring of 1941. The elegance of the Bf 109 crested with the "Friedrich". Following a largely defensive stance over the Channel and northern France, the Bf 109F took on a more offensive role in Operation Barbarossa in the east, and in northern Africa. In later duties with the 'Jagdarmee' during the second phase of the war in the east, and in the 'Defense of the Reich' from 1943 to 1945, the Bf 109 served in the form of the G version, followed by the K. Even it was clear the development of the Bf 109 was depleted by the end of the war the aircraft was still able to keep pace with the foes that it encountered. Besides its primary purpose as a fighter, the Bf 109 also appeared as a fighter-bomber, reconnaissance platform, night fighter, trainer and rammjäger.

#### The kit: Bf 109G-14

The Bf 109G series (Gustav) was a direct follow-on of the Bf 109F. The main difference was the more powerful DB 605 engine, which was the development of previous DB 601. Several marks were produced, but all the later variants were modified versions of the most numerous Bf 109G-6. Early in 1944, the DB 605AS engine with larger superchargers for improved high-altitude performance became available as well as MW-50 water injection for improved low-to-medium altitude performance (DB 605AM). With these two features combined, the engine was marked DB 605ASM.

The Bf 109G-14 arrived in July 1944 as an attempt to create a standard type, incorporating many changes introduced during production of the G-6. These ongoing modifications led to many different sub-variants, making the production more and more complicated. The new type offered improved combat performance, as MW 50 device increased output to 1,775 hp (1,324 kW). With the G-14 the Erla Haube canopy also became standard.

In the middle of 1944 use of plywood in the construction of some parts of the Bf 109 became more and more common due to the metal supplies shortage. One of such a parts was a taller fin and rudder, used in production for many G-14s and supplied by several sub-contractors. Apart of the standard Bf 109G-14, four other sub-variants were developed: G-14/AS (high-altitude fighter; DB 605ASM engine; MW 50 boost), G-14/ASy (high-altitude command fighter), G-14y (command fighter) and G-14/U4 (standard G-14 with 30mm engine mounted MK 108 Motorkanone instead of 20 mm MG 151/20). Altogether some 5,500 Bf 109G-14s were built.

ATTENTION



UPOZORNĚNÍ



ACHTUNG



ATTENTION



注意



Carefully read instruction sheet before assembling. When you use glue or paint, do not use near open flame and use in well ventilated room. Keep out of reach of small children. Children must not be allowed to suck any part, or pull vinyl bag over the head.



Před započítím stavby si pečlivě prostudujte stavební návod. Při používání barev a lepidel pracujte v dobře větrané místnosti. Lepidla ani barvy nepoužívejte v blízkosti otevřeného ohně. Model není určen malým dětem, mohlo by dojít k požití drobných dílů.

INSTRUCTION SIGNS \* INSTR. SYMBOLS \* INSTRUKTION SINNBILDEN \* SYMBOLES \* 記号の説明

OPTIONAL  
VOLBABEND  
OHNOUTSAND  
BROUSITOPEN HOLE  
VYVRTAT OTVORSYMETRICAL ASSEMBLY  
SYMETRICKÁ MONTÁŽREMOVE  
ODRÍZNOUTREVERSE SIDE  
OTOČITAPPLY EDUARD MASK  
AND PAINT  
POUŽÍT EDUARD MASK  
NABARVIT**PLEASE, CHECK THE LATEST VERSION OF THE INSTRUCTIONS ON [www.eduard.com](http://www.eduard.com)**

PARTS



DÍLY



TEILE



PIÈCES



部品

## PLASTIC PARTS

N2&gt;

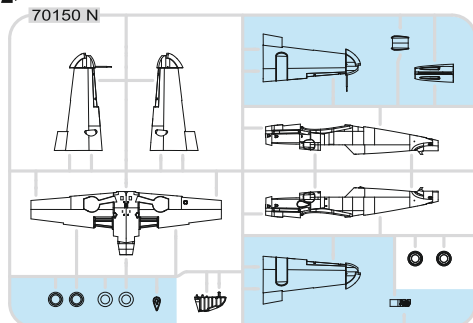

U&gt;

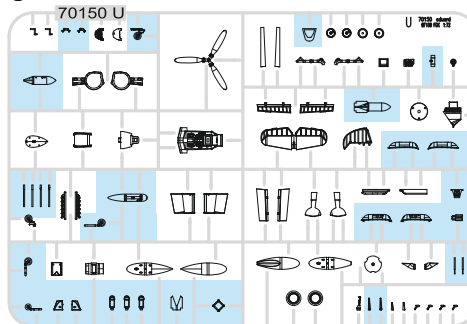

J&gt;

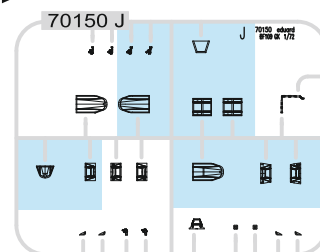

V&gt;

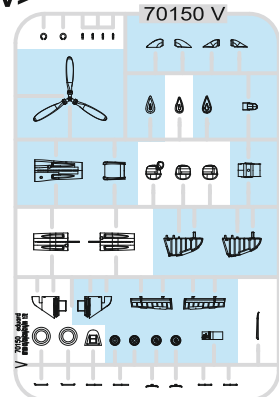
eduard  
MASK

## PE - PHOTO ETCHED DETAIL PARTS 2 pcs.

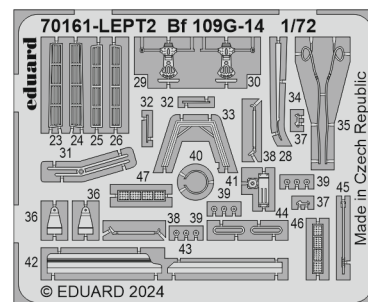
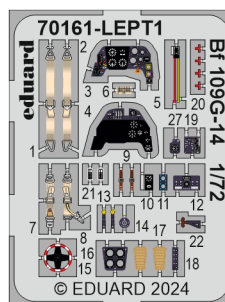

-Parts not for use. -Teile werden nicht verwendet. -Pièces à ne pas utiliser. -Tyto díly nepoužívejte při stavbě. - 使用しない部品

COLOURS



BARVY



FARBEN



PEINTURE



色

GSI Creos (GUNZE)		
AQUEOUS	Mr.COLOR	
H2	C2	BLACK
H11	C62	FLAT WHITE
H12	C33	FLAT BLACK
H47	C41	RED BROWN
H64	C17	RLM71 DARK GREEN
H65	C18	RLM70 BLACK GREEN
H67	C115	RLM65 LIGHT BLUE
H68	C36	RLM74 DARK GRAY
H69	C37	RLM75 GRAY
H70	C60	RLM02 GRAY
H77	C137	TIRE BLACK
H90	C47	CLEAR RED
H94	C138	CLEAR GREEN
H324	C324	LIGHT GRAY
H413	C113	RLM04 YELLOW

GSI Creos (GUNZE)		
AQUEOUS	Mr.COLOR	
H414	C114	RLM23 RED
H416	C116	RLM66 BLACK GRAY
H417	C117	RLM76 LIGHT BLUE
H421	C121	RLM81 BROWN VIOLET
H422	C122	RLM82 LIGHT GREEN
Mr.METAL COLOR		
MC213		STEEL
MC214		DARK IRON
MC219		BRASS
Mr.COLOR SUPER METALLIC		
SM201		SUPER FINE SILVER
Mr.COLOR GX		
GX05		SUSIE BLUE

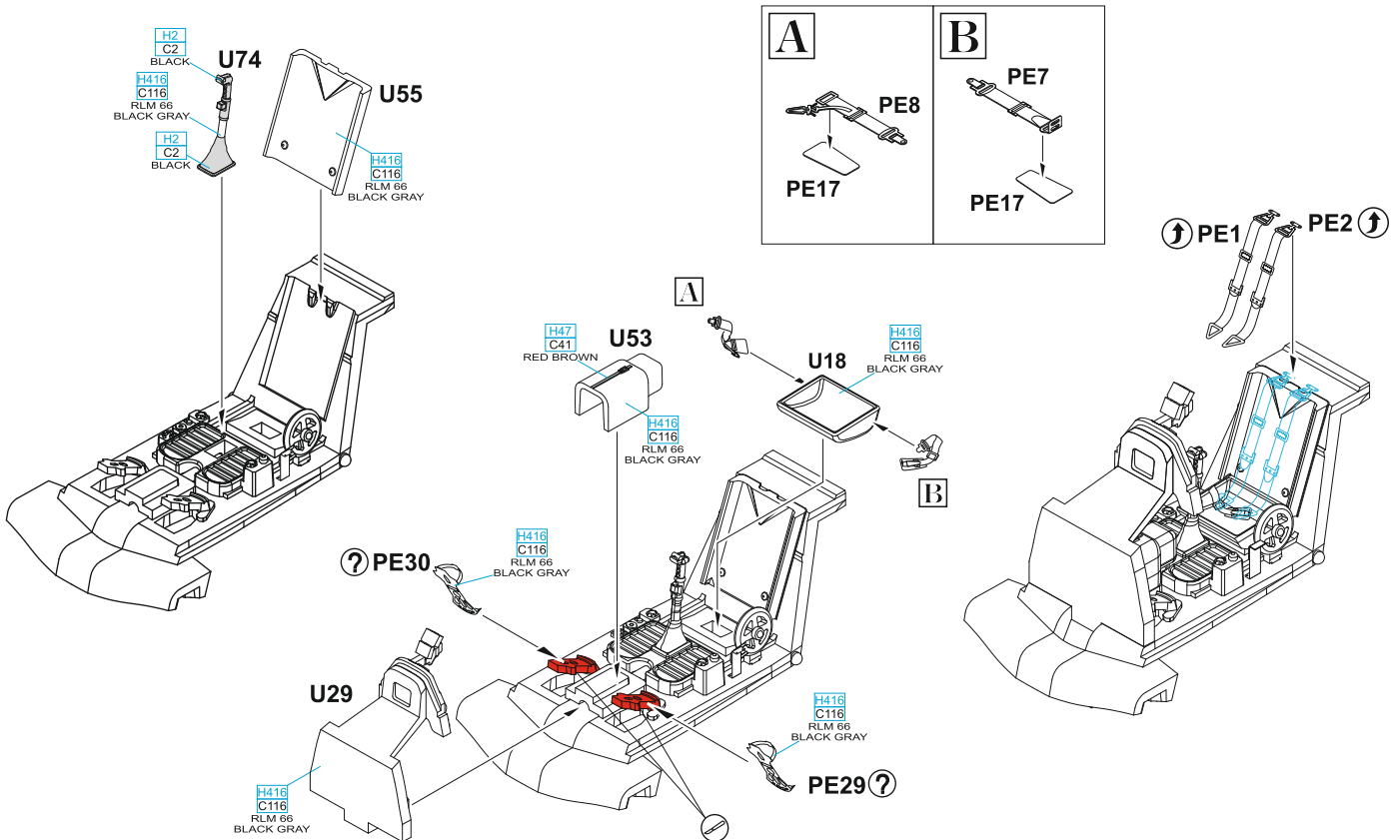
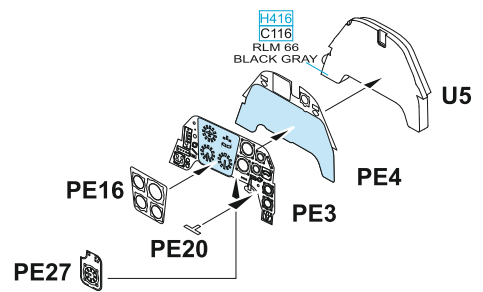
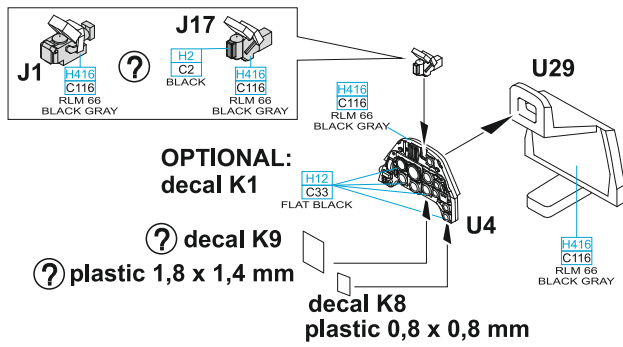
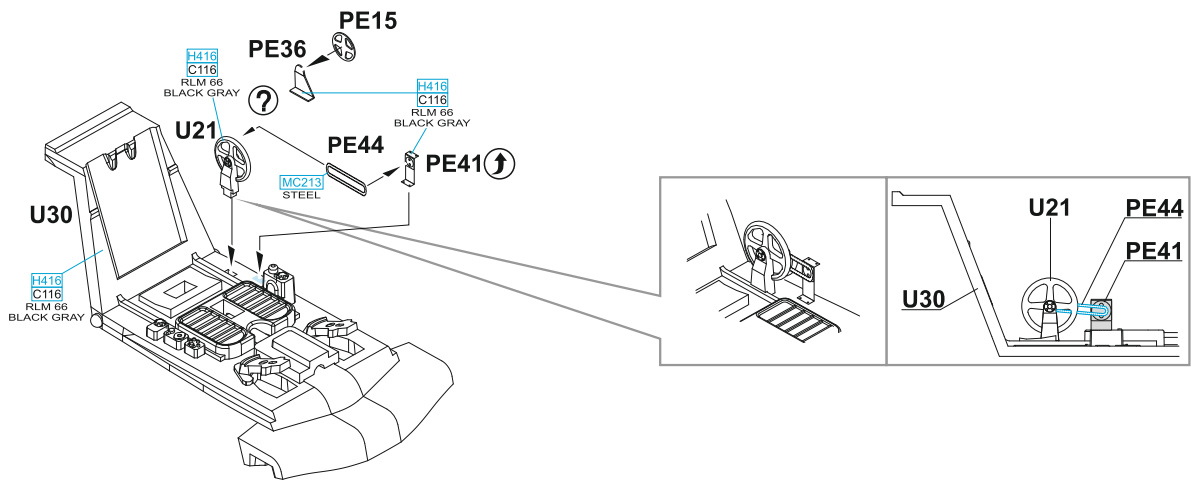

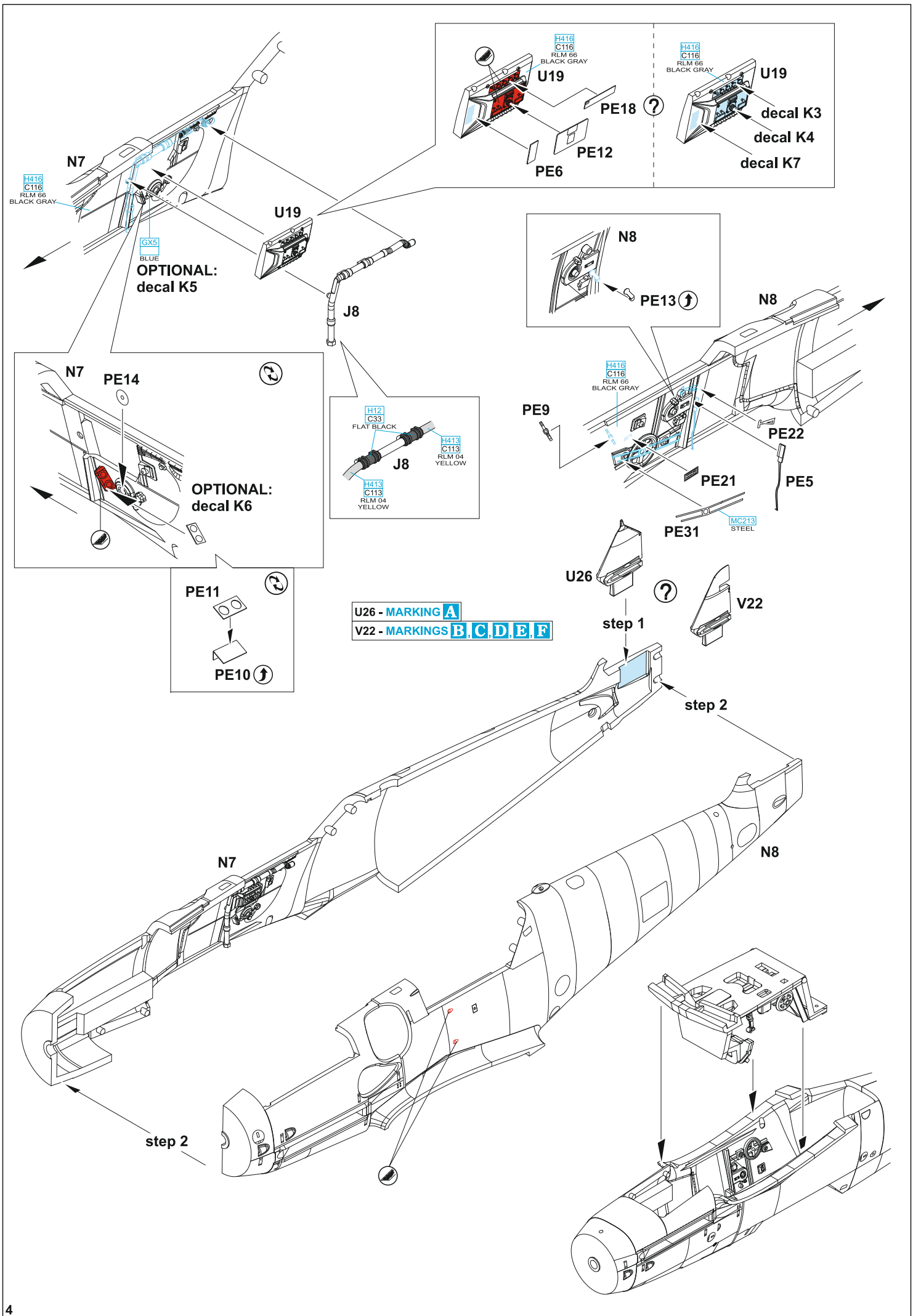

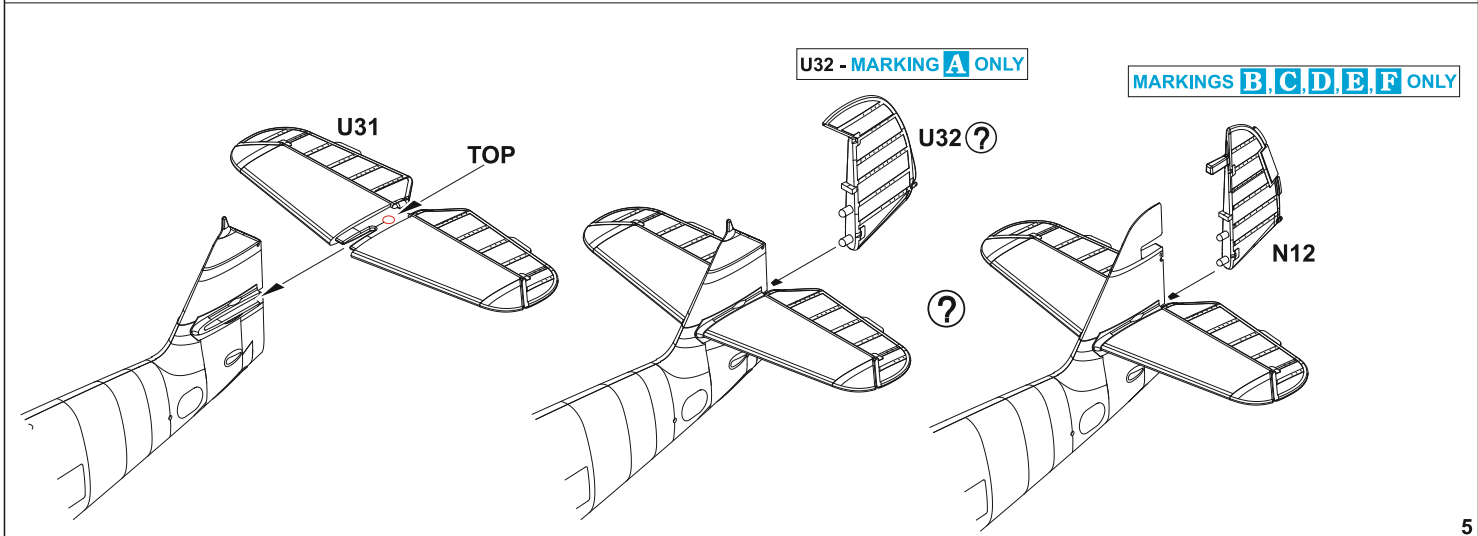
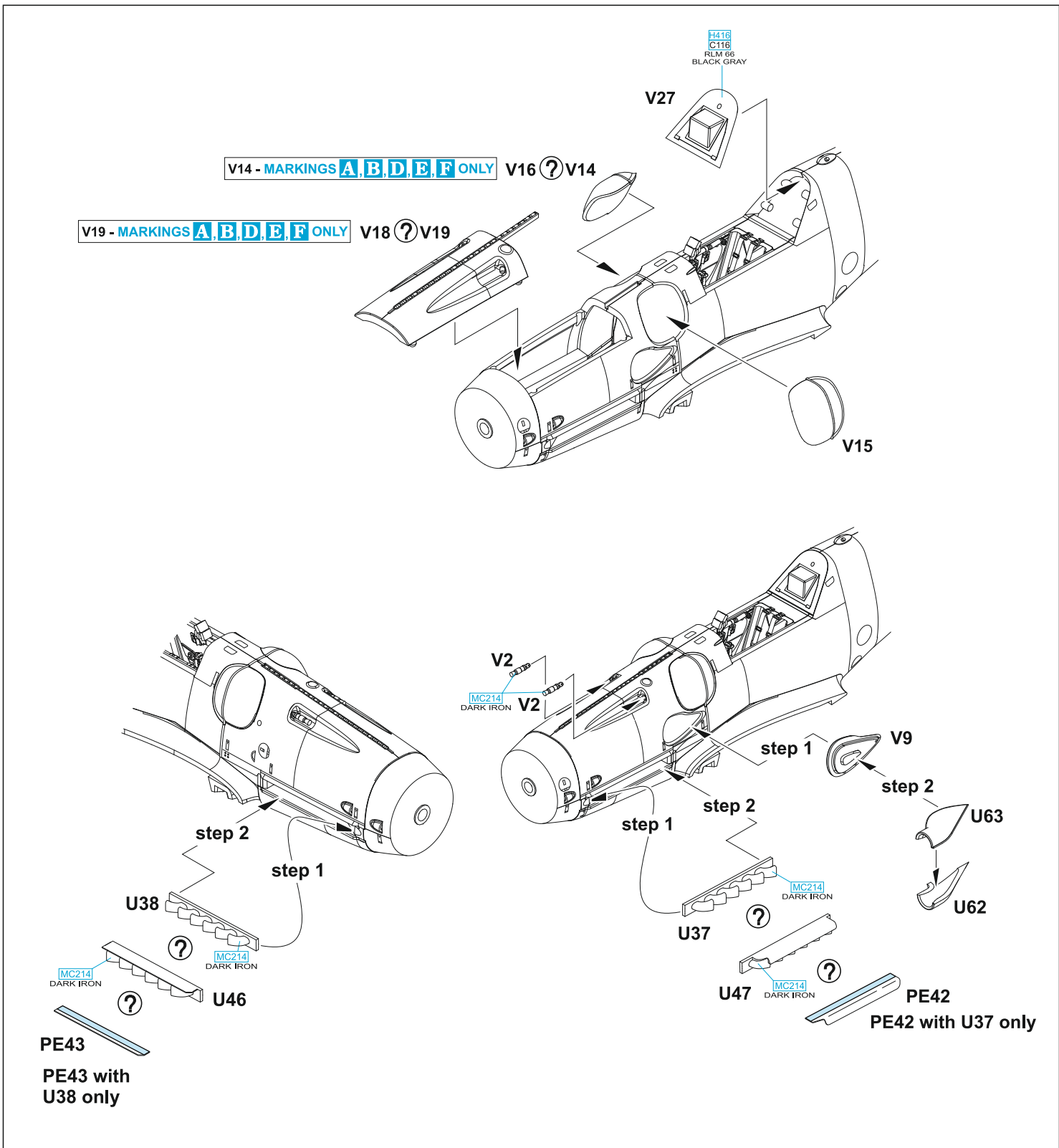

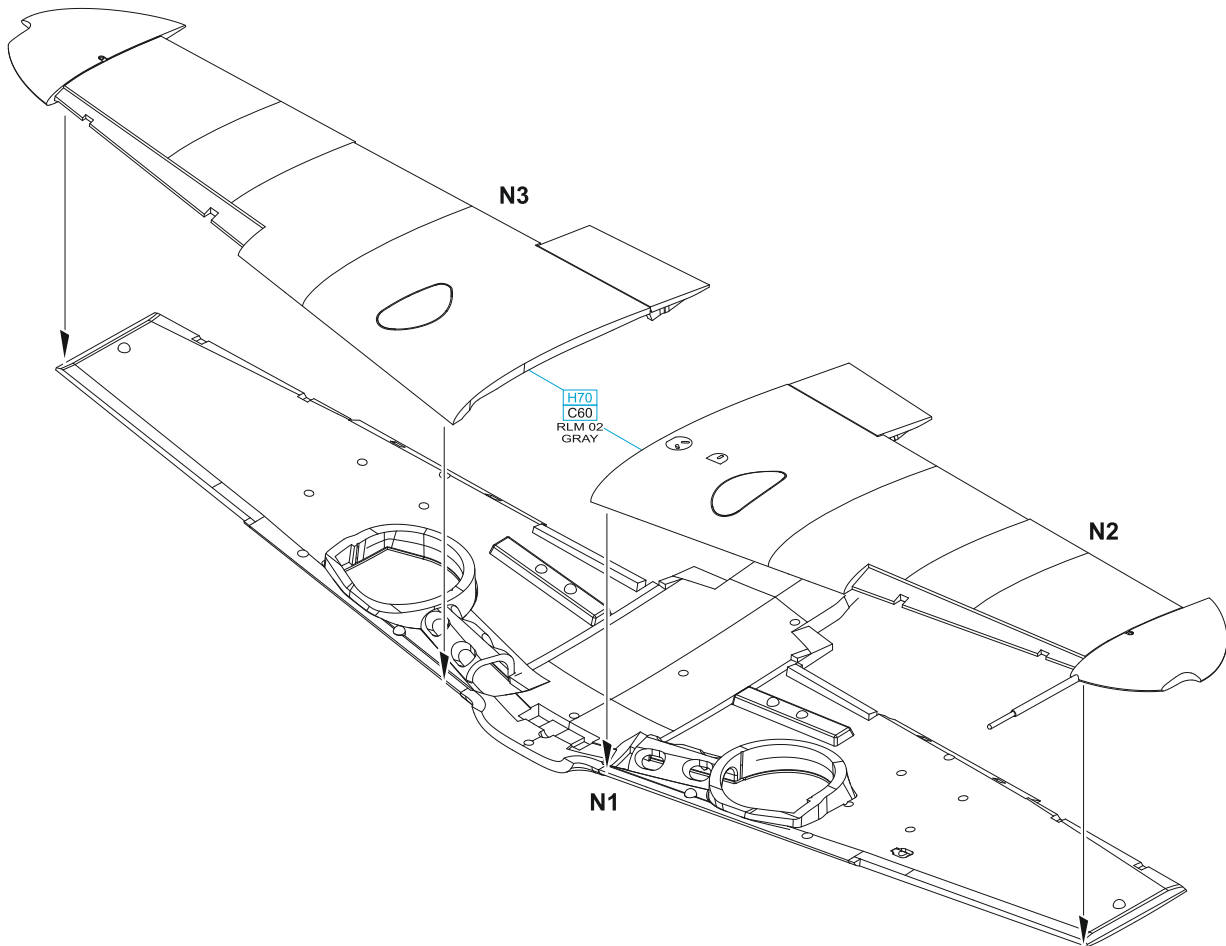
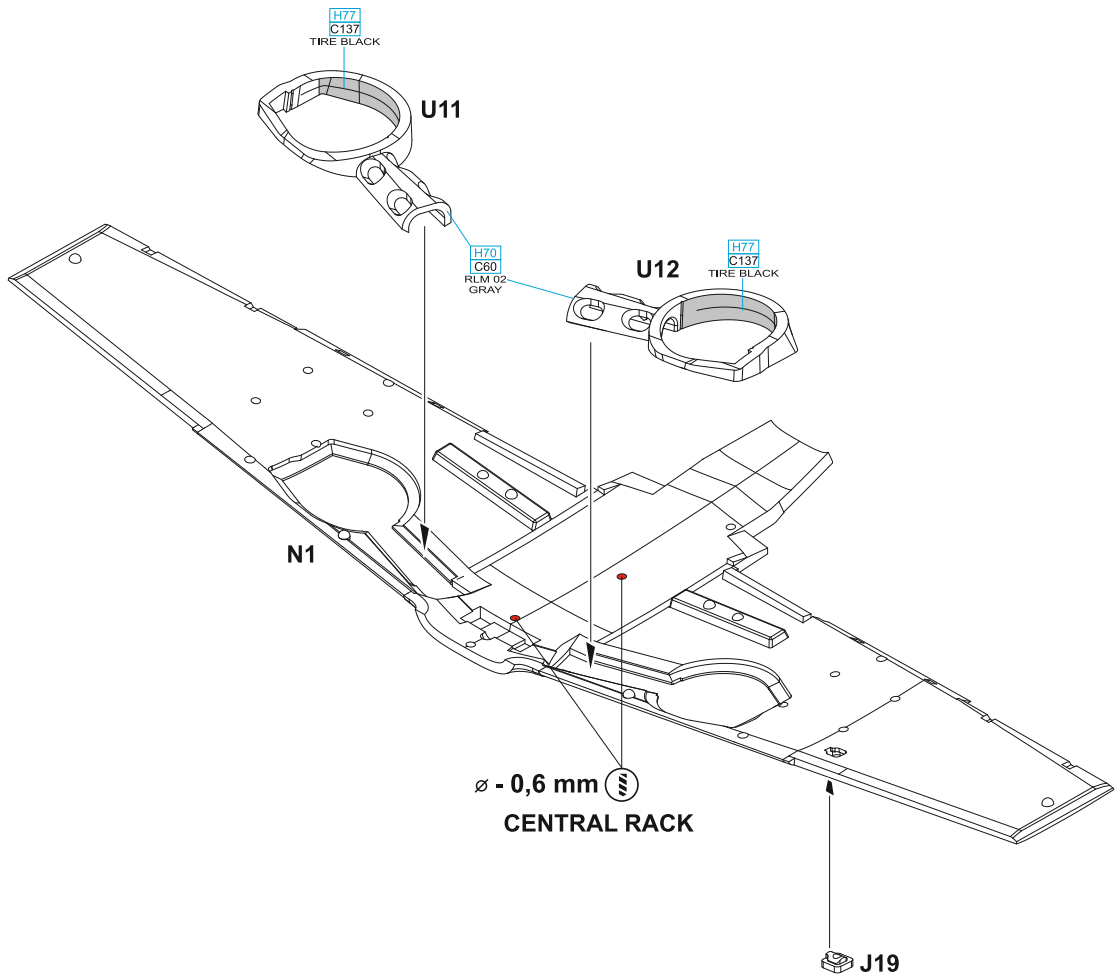

# CLOSE

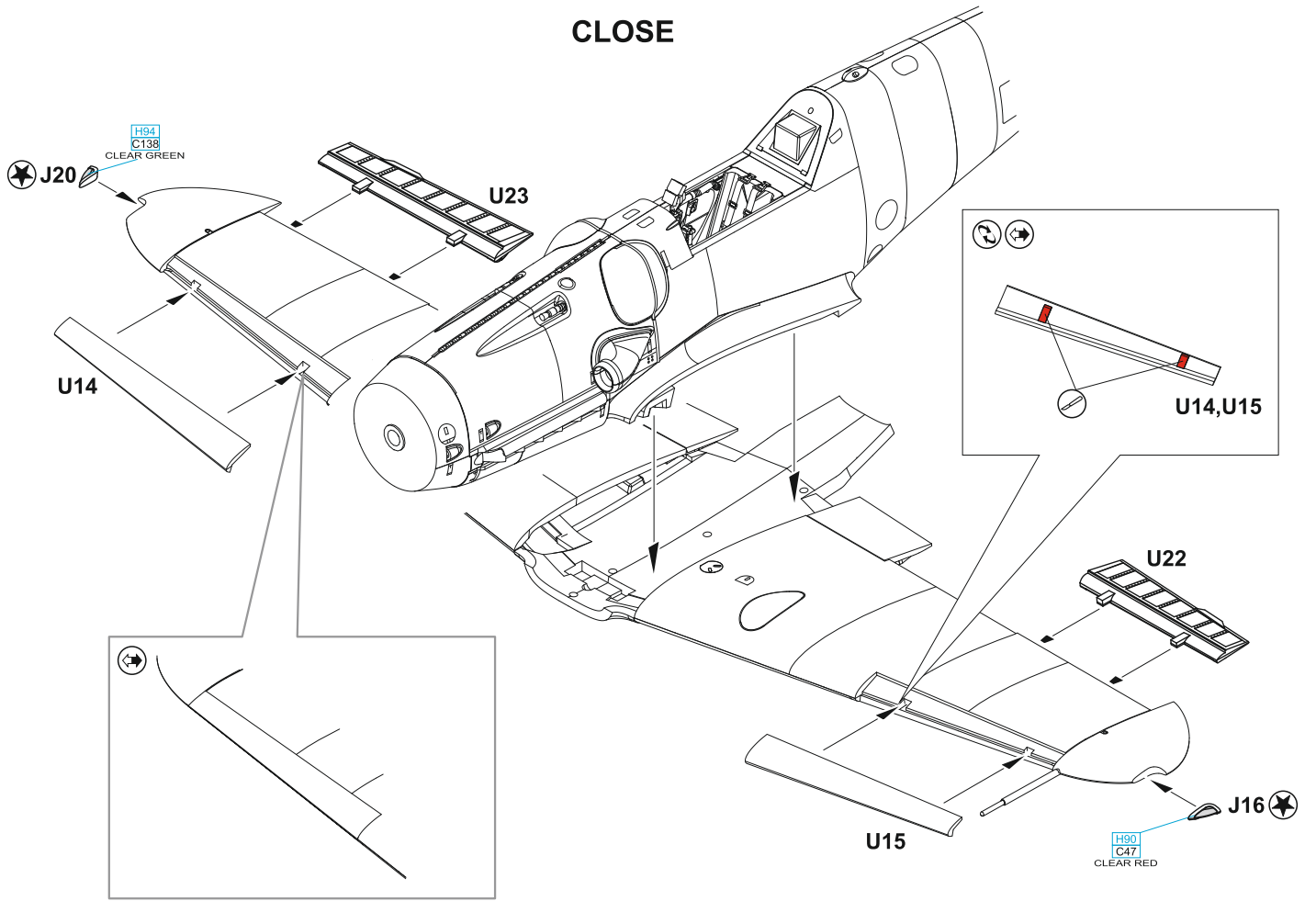

# OPEN

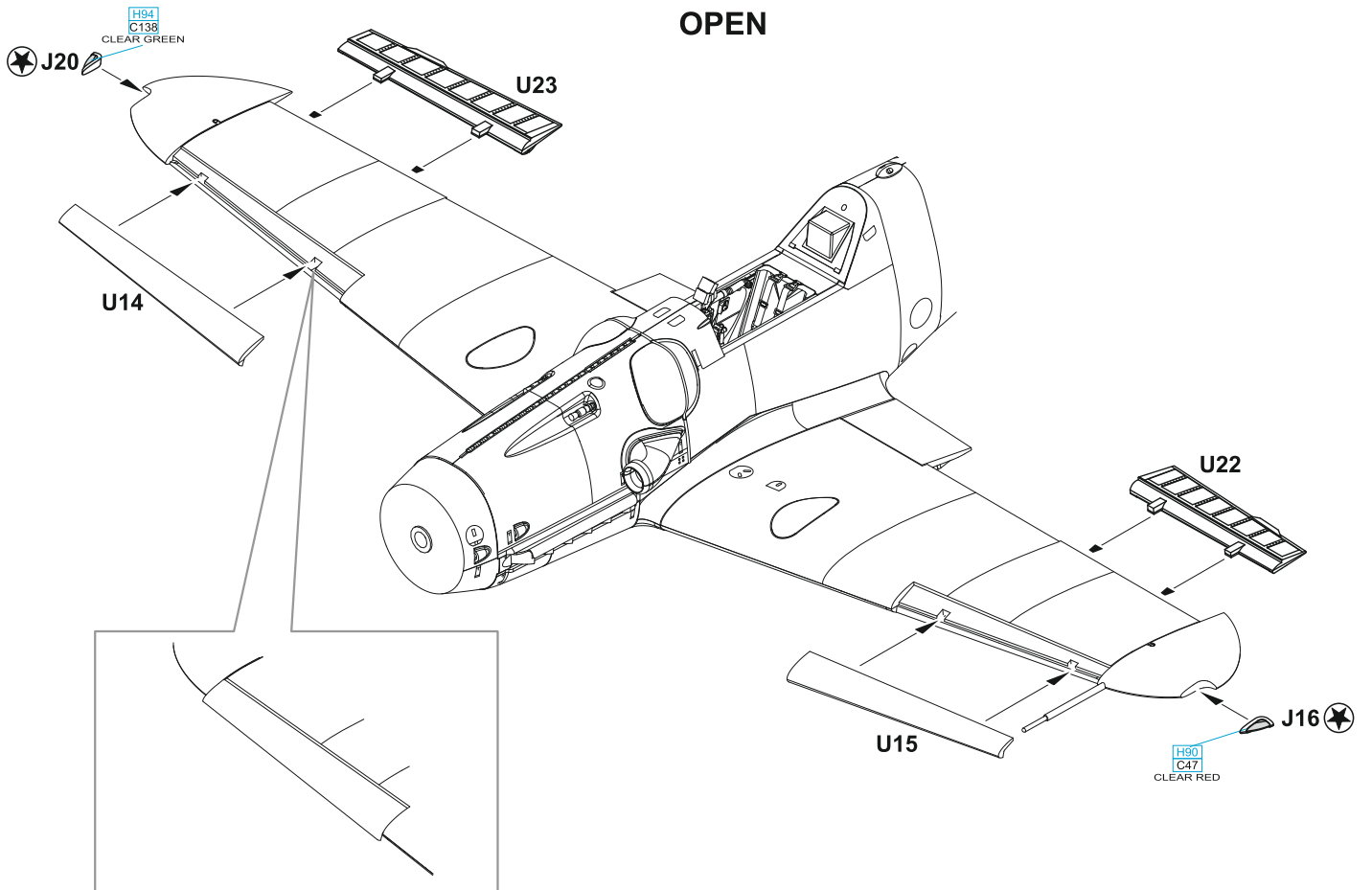

**FRONT VIEW**

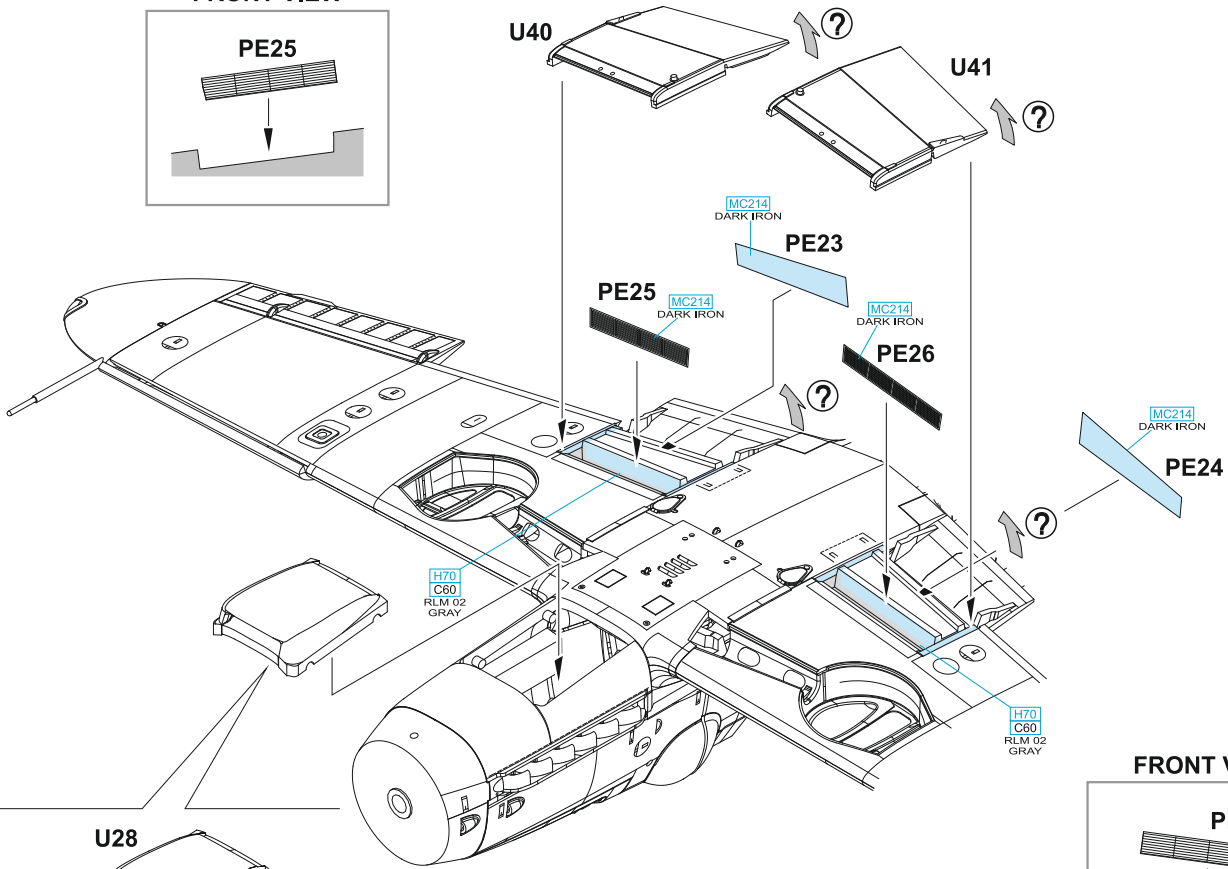
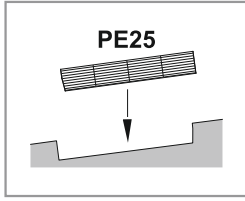

**U28**

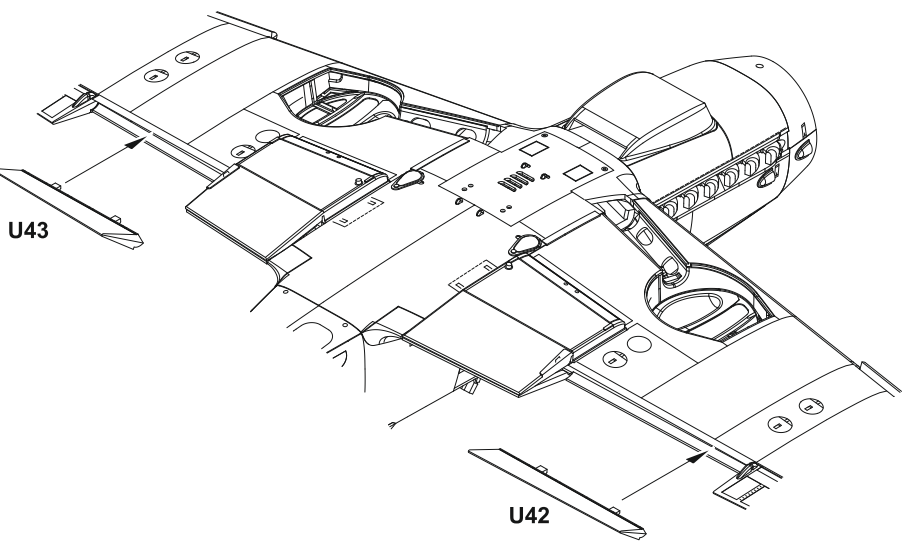
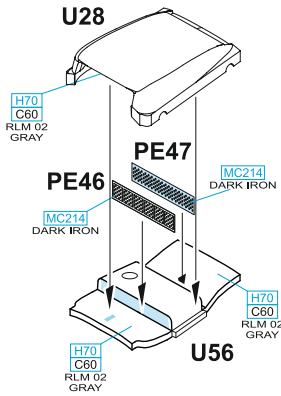

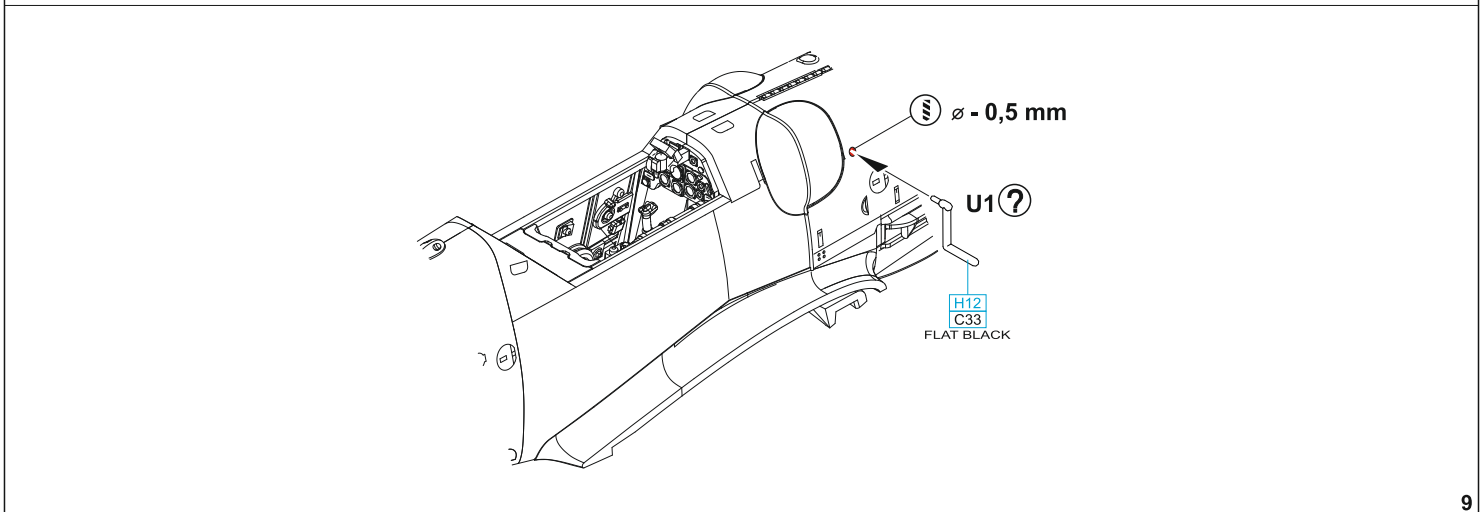
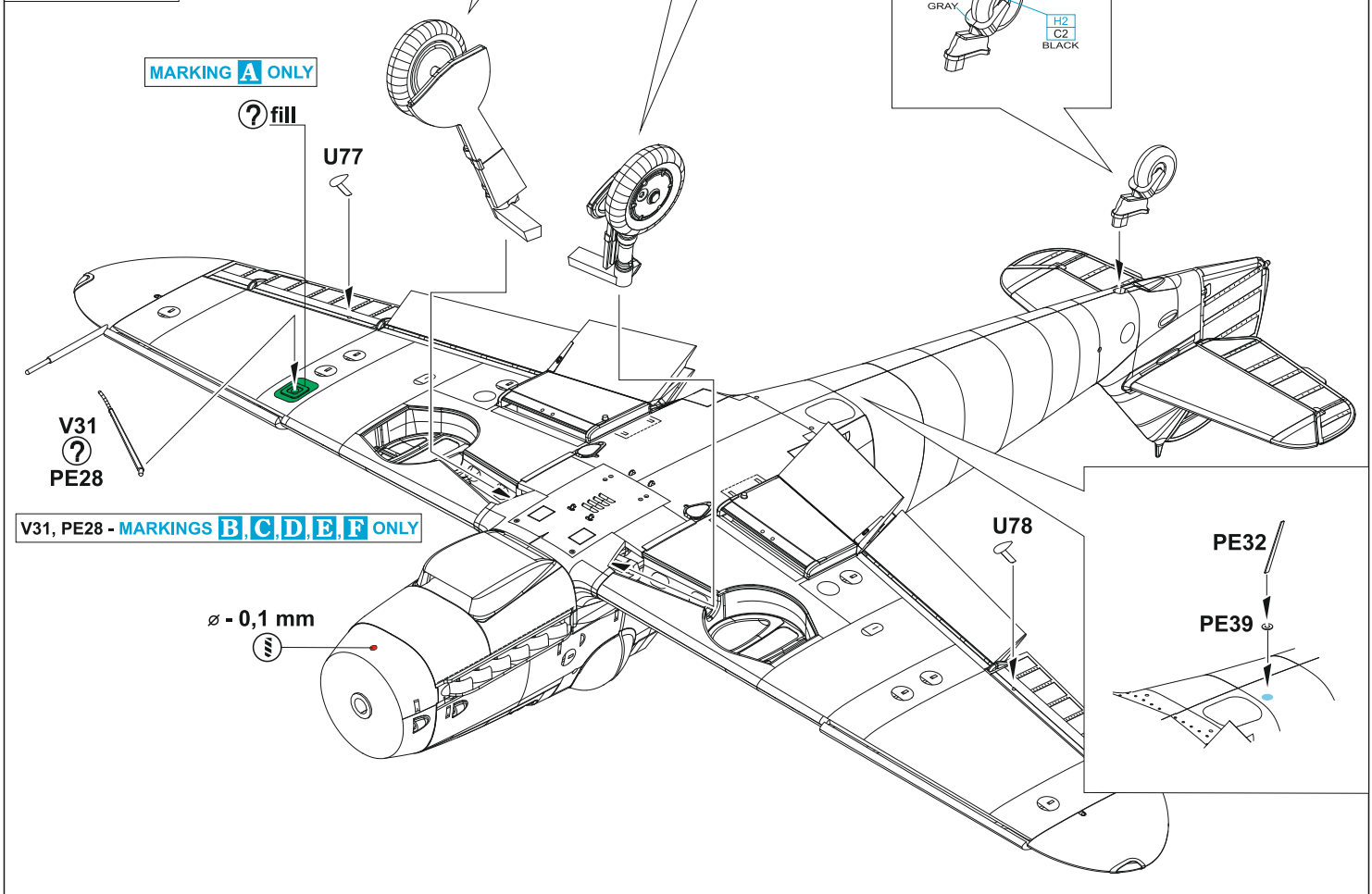
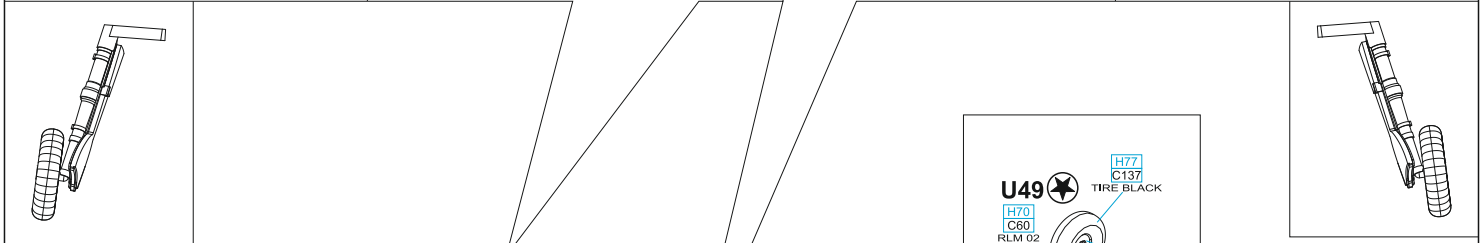
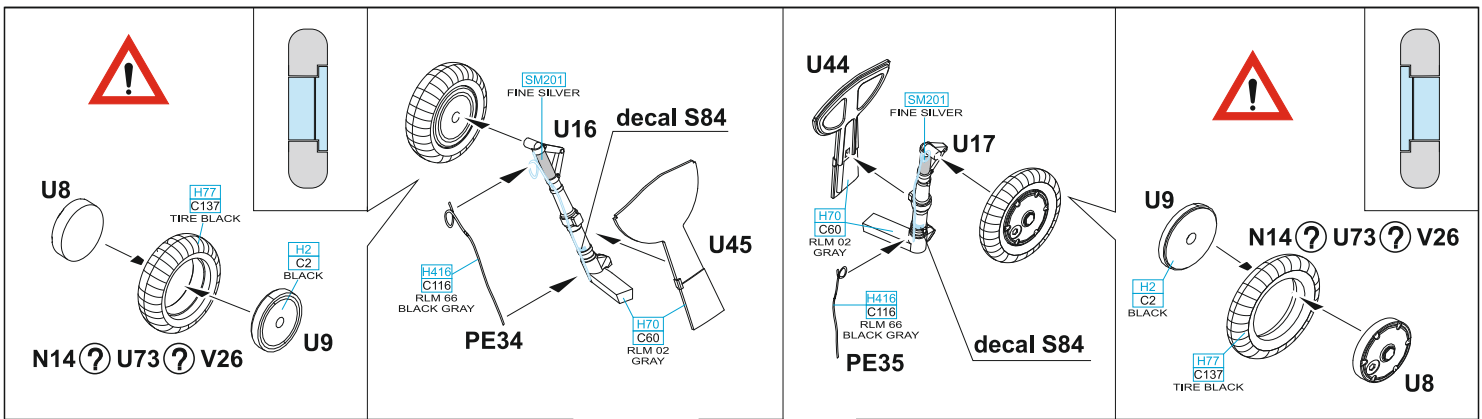

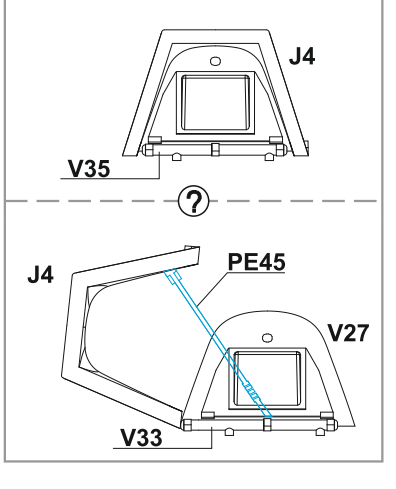
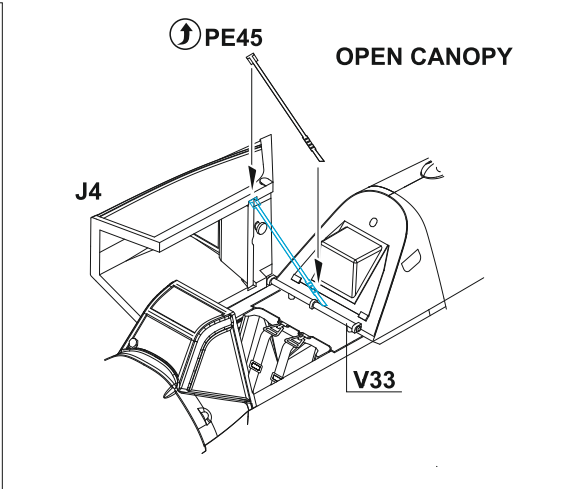
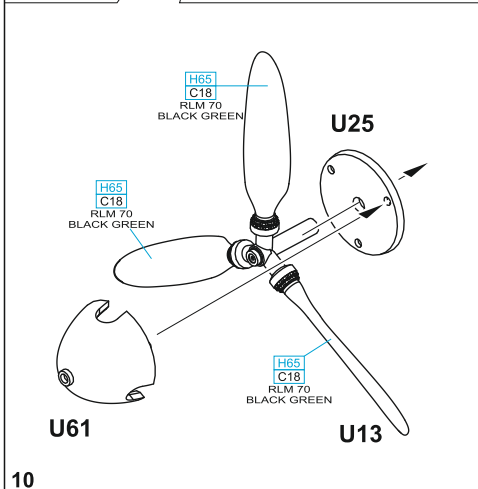
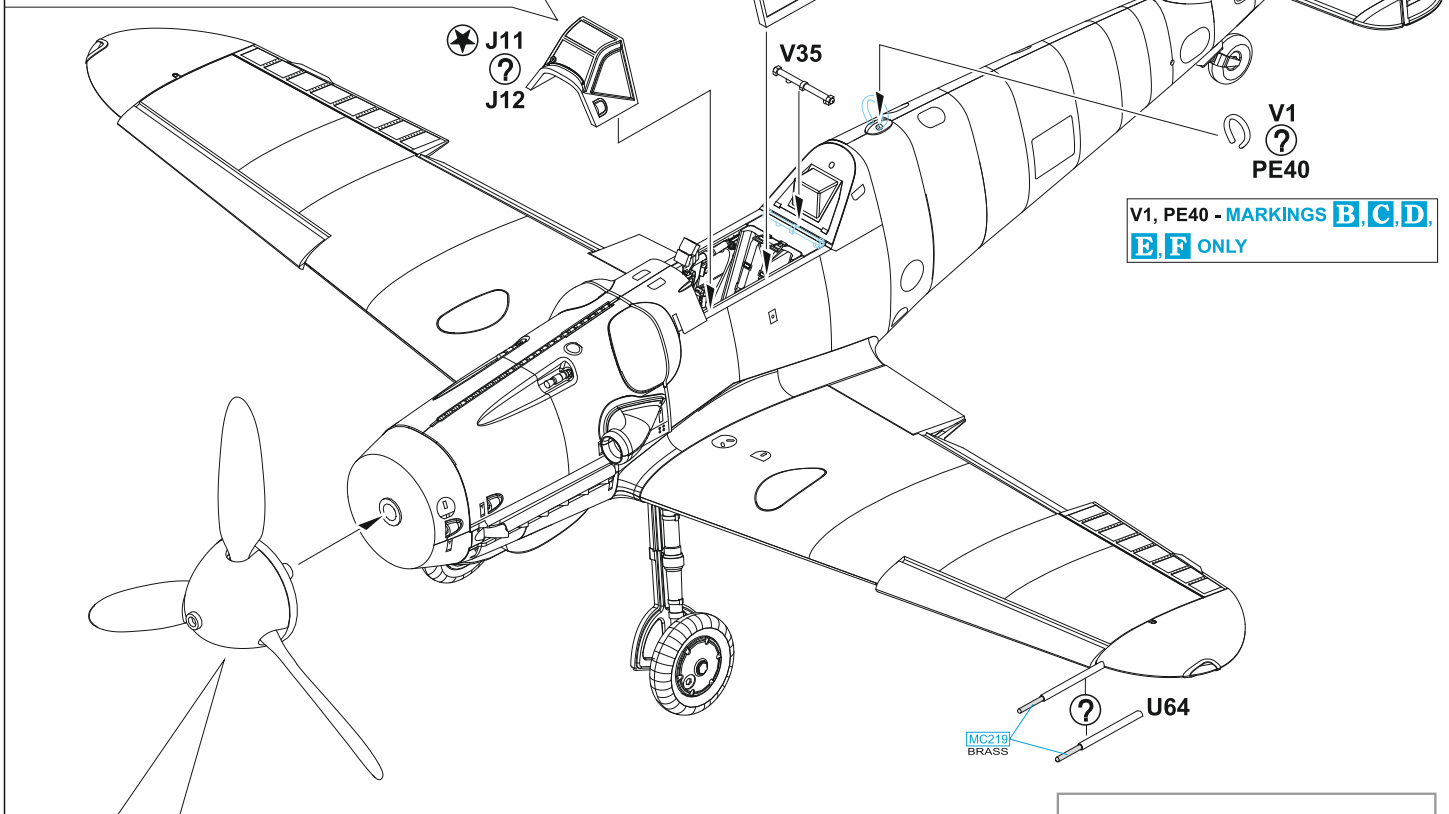
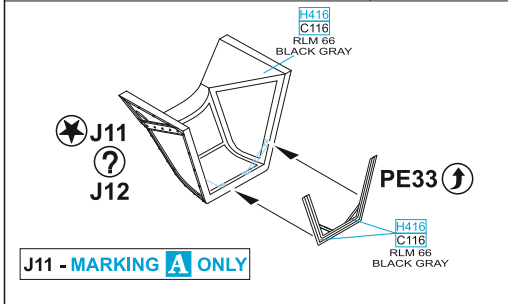
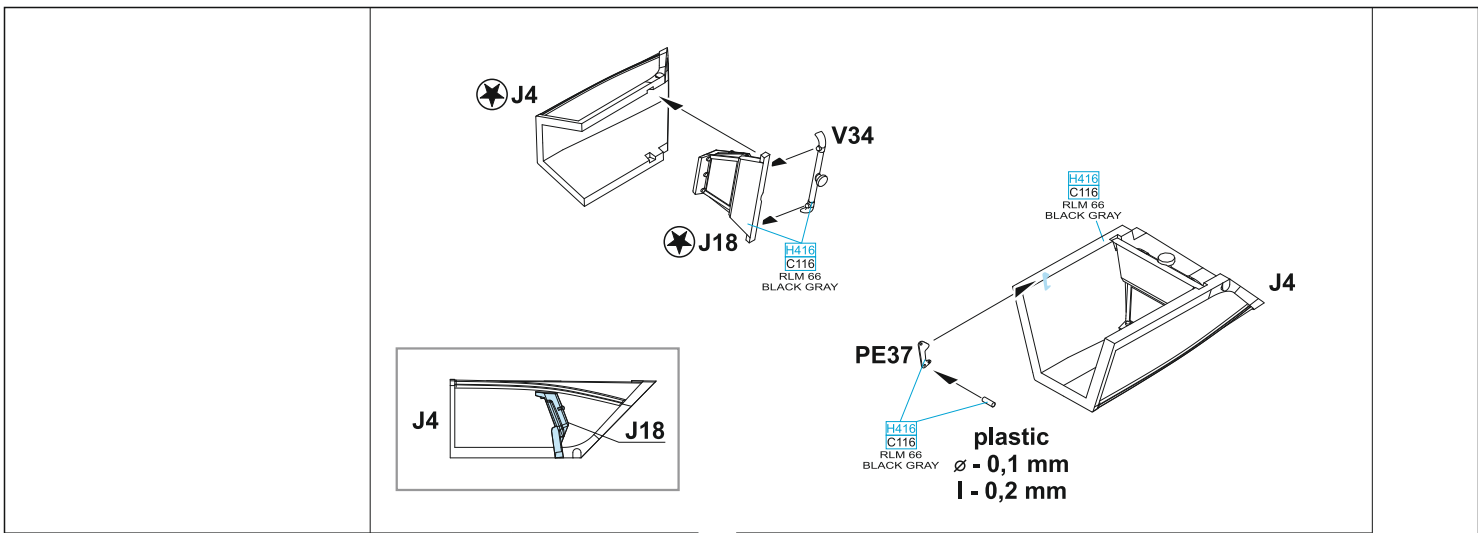

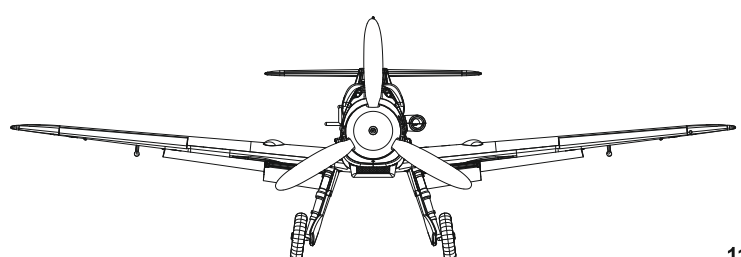
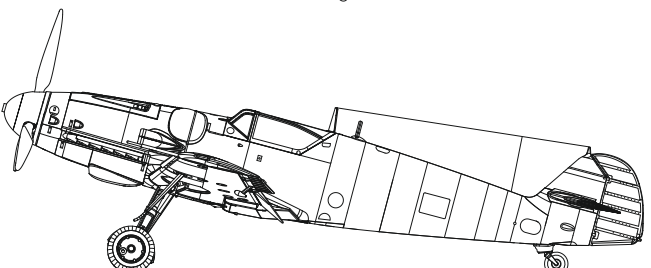
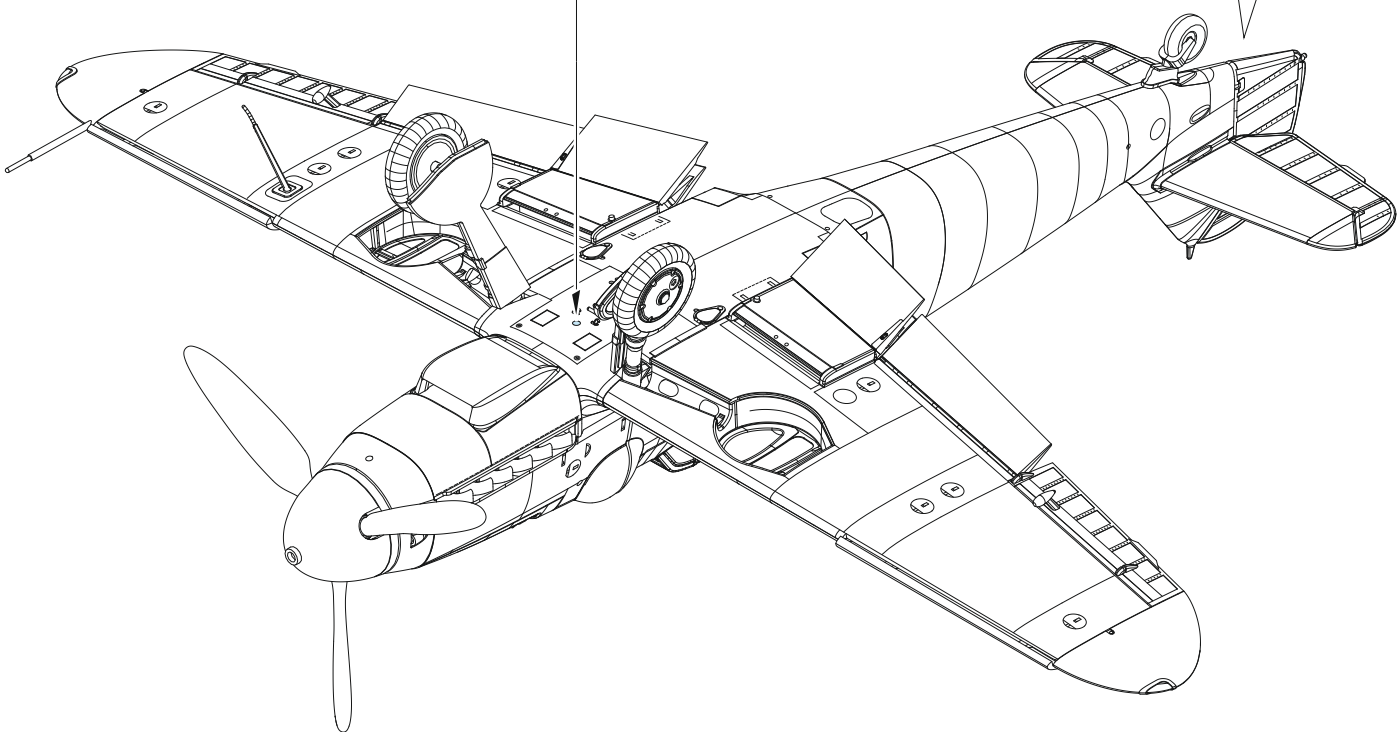
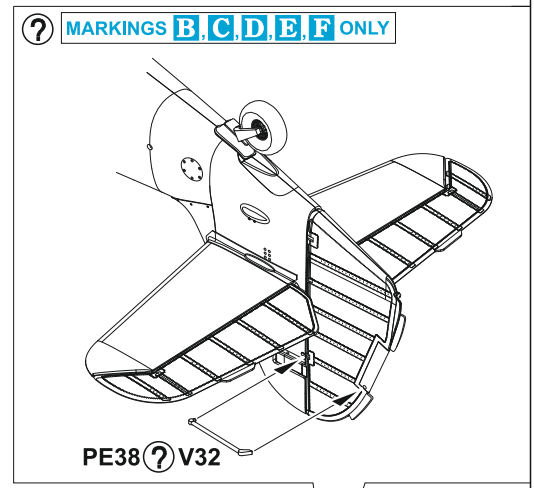
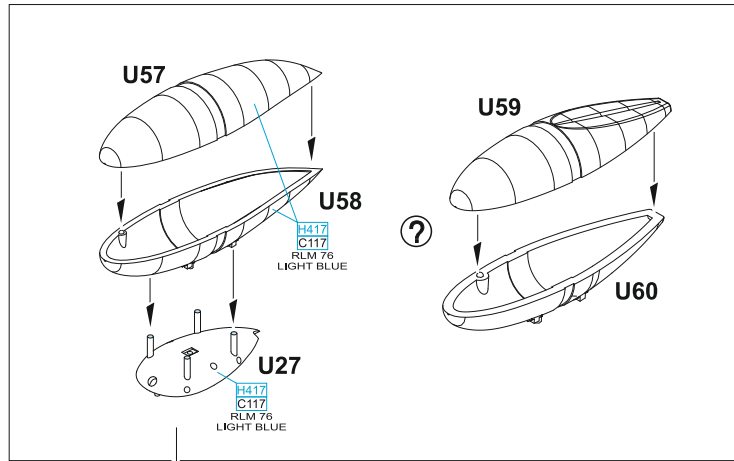

eduard  
MASK

70161

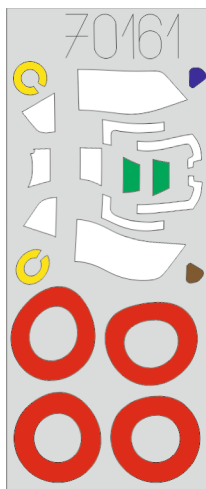
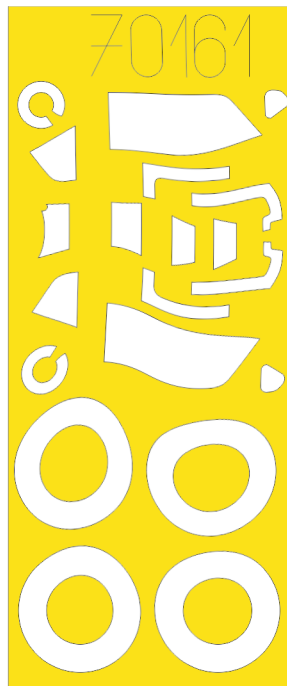

N14 ? U73 ? V26

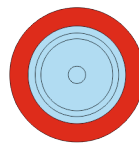
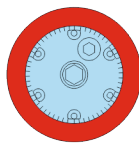

U49



J16



J18

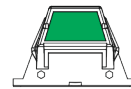

J20



J4

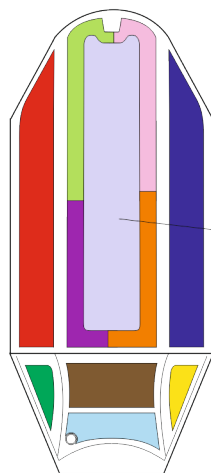
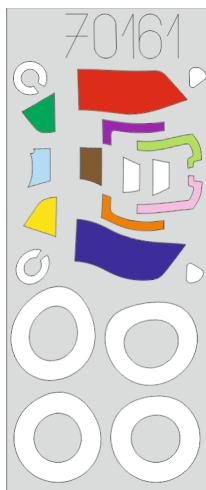

LIQUID MASK

J11 ? J12

# A Hptm. Erich Hartmann, CO of 4./JG 52, Csór, Hungary, November 1944

Erich Hartmann, the most successful fighter pilot of all times, joined the 7. Staffel of JG 52 on October 10, 1942, as his first unit to serve with. He remained with Jagdgeschwader 52 till the end of World War Two; in fact, he became the commander of its I. Gruppe. The total count of his victories is believed to be 352. For his exceptional success he was awarded the Knight's Cross of the Iron Cross with Oak Leaves, Swords and Diamonds. After WWII he was transferred to the POW camp in the Ural Mountains in the Soviet Union and was not released until 1955. The following year he joined the ranks of Western German Luftwaffe. He became the commander of JG 71, the first fighter plane Luftwaffe squadron equipped with jet fighter aircraft. Hartmann retired in 1970 and died on September 20, 1993. Standard camouflage of Hartmann's White 1 was complemented by black tulip outlined in white on the nose of the aircraft. This was the appearance from the time of his command of 4. Staffel. On the left side, underneath the cockpit, there was a heart with Hartmann's wife's name written over it. The yellow bottom wingtips and the yellow band around the rear fuselage were markings of the aircraft serving on the Eastern Front. The photograph of the nose of this aircraft shows that the engine cover is identical to those produced by Erla factory in Leipzig.

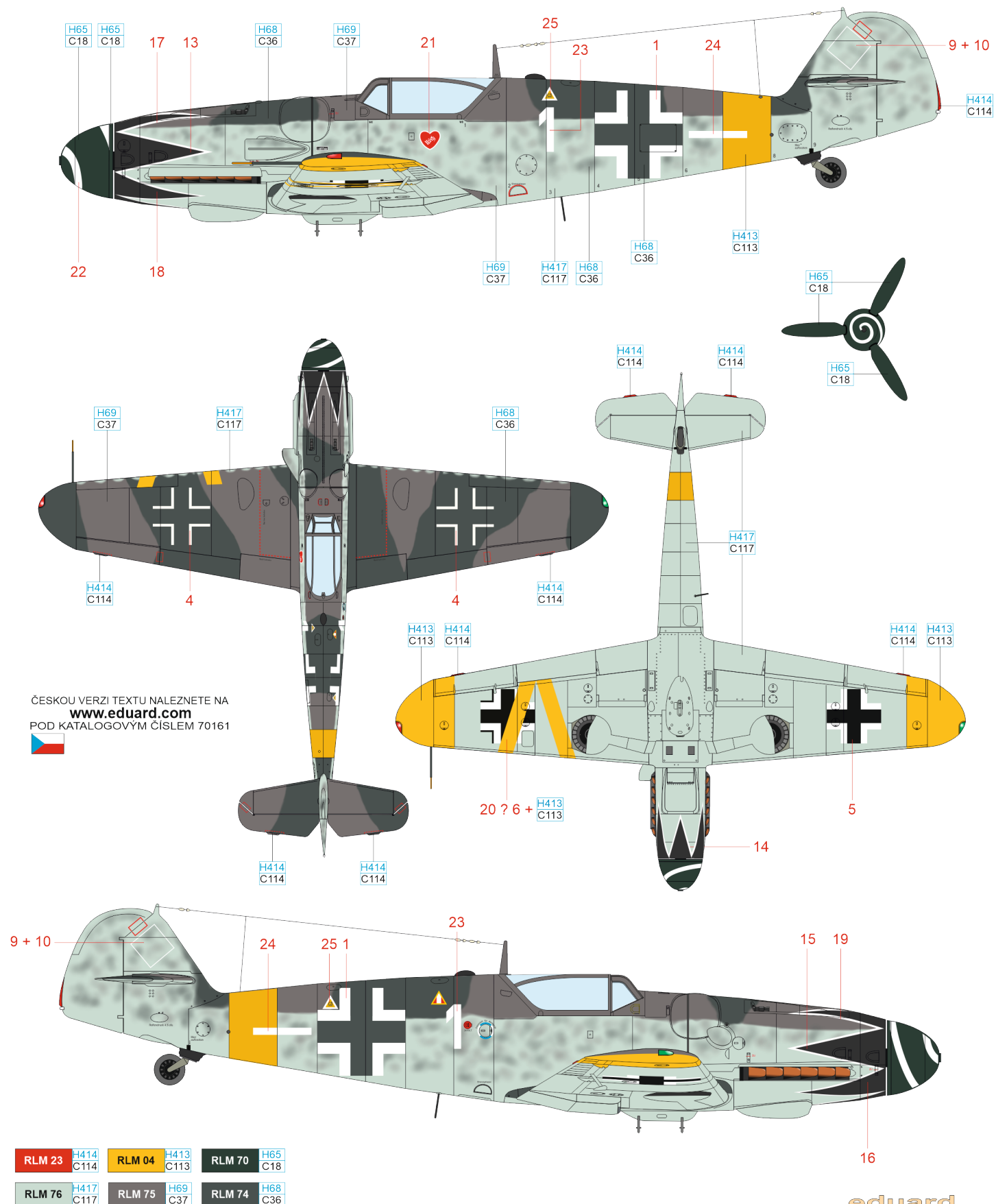







# E WNr. 464068, Str. Josip Ceković, 2. ZLJ (Zrakoplovno Lovачko Jato), Iesi airfield, Italy, April 1945

After the Red Army's summer offensive in 1944 on the southern front and its troops' entry into Hungary and Romania, the German High Command had to address the security of its positions in the Balkans. One of the components of this effort was the Croatian Air Force. To strengthen it, the delivery of thirty new Bf 109Gs was arranged in three stages during October 1944. By November 1944, the Croats had already received ten Bf 109Gs. On December 1, 1944, these aircraft landed at Lučko airfield near Zagreb and were assigned to the 2. Zrakoplovno Lovачko Jato (ZLJ). Subsequently, the 2. ZLJ was incorporated into the Defence of the Reich and stationed at Borongaj airfield. In January 1945, additional Bf 109Gs were delivered, making the 2. ZLJ the only combat-ready unit on this section of the front. Its combat operations were diverse, engaging Soviet forces, domestic Communist forces, USAAF and RAF units. The Black 10 aircraft had its original German crosses repainted. Also a yellow fuselage band was overpainted as well as a yellow V on the bottom of the wing. On April 16, 1945, Str. Josip Ceković defected to Iesi airfield in Italy with this aircraft.

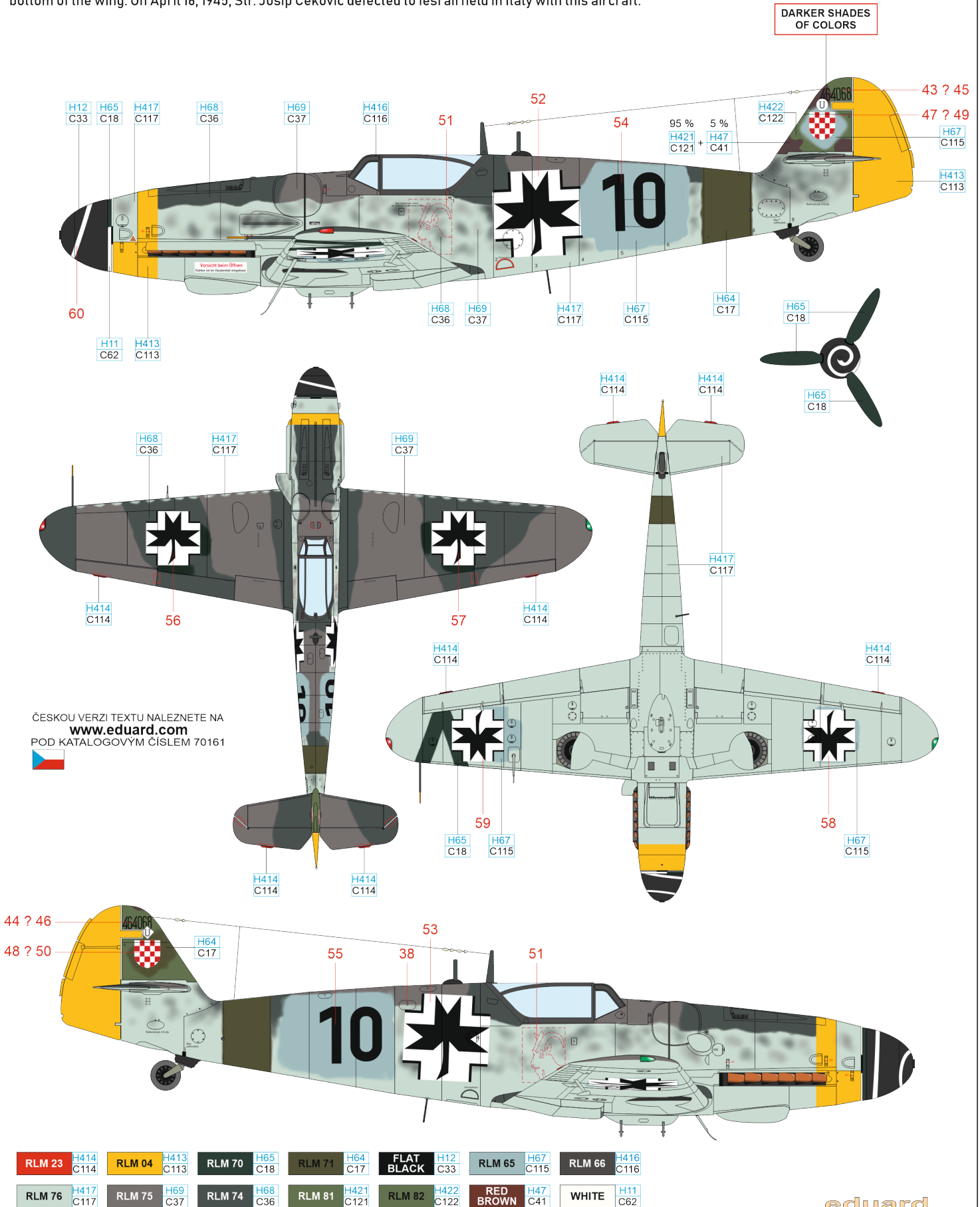

DARKER SHADES OF COLORS

ČESKOU VERZI TEXTU NALEZNETE NA [www.eduard.com](http://www.eduard.com) POD KATALOGOVÝM ČÍSLEM 70161



RLM 23	H414 C114	RLM 04	H413 C113	RLM 70	H65 C18	RLM 71	H64 C17	FLAT BLACK	H12 C33	RLM 65	H67 C115	RLM 66	H416 C116
RLM 76	H417 C117	RLM 75	H69 C37	RLM 74	H68 C36	RLM 81	H421 C121	RLM 82	H422 C122	RED BROWN	H47 C41	WHITE	H11 C62



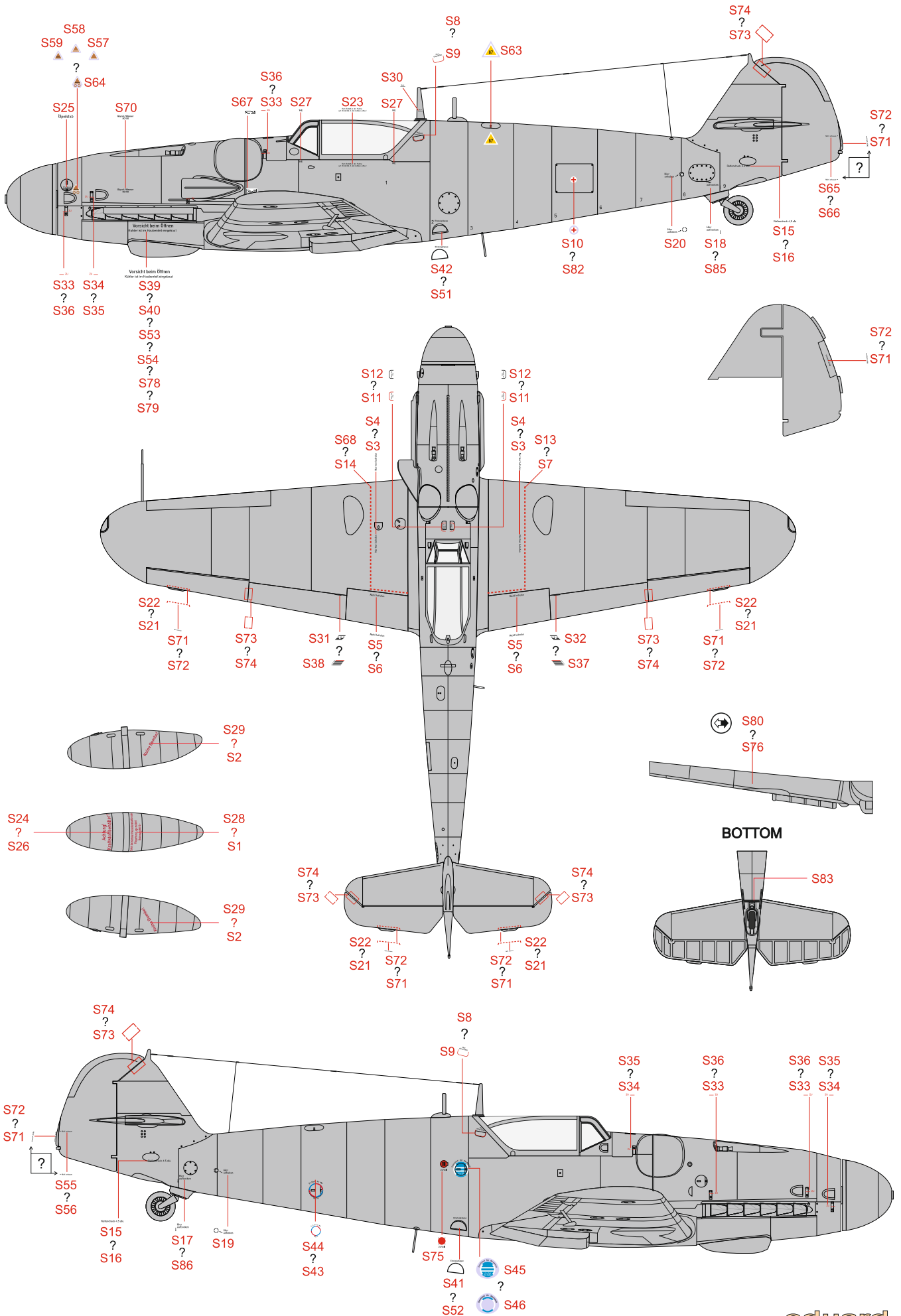

# Eduard goodies for

# Bf 109G-14 1/72

- 672292 Luftwaffe rudder pedals PRINT (Brassin)
- 672329 Bf 109 balance weights PRINT (Brassin)
- 672338 Bf 109G undercarriage legs BRONZE (Brassin)
- 672344 Bf 109G radio compartment PRINT (Brassin)
- 672346 Bf 109G propeller PRINT (Brassin)
- 672347 Bf 109G-5/G-6 cockpit PRINT (Brassin)
- 672348 Bf 109G-5/G-6 wheels PRINT (Brassin)
- 672352 Bf 109G-6 engine PRINT (Brassin)
- 672355 Bf 109G-5/G-6 gun barrels PRINT (Brassin)
- D72048 Bf 109G stencils (Decal Set)

# 672352

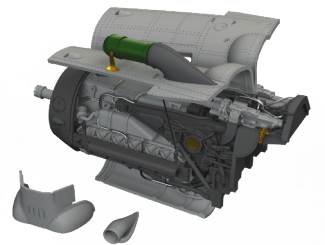

# 672329

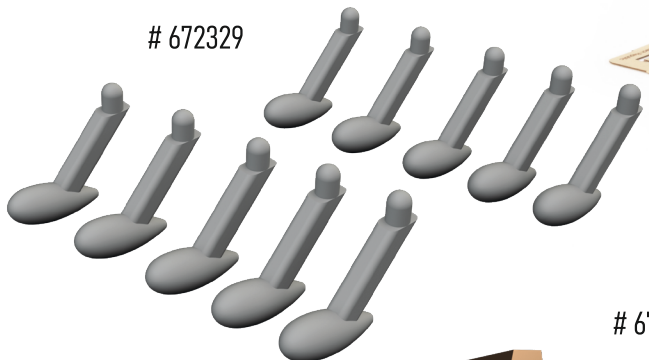

# 672338



# 672292

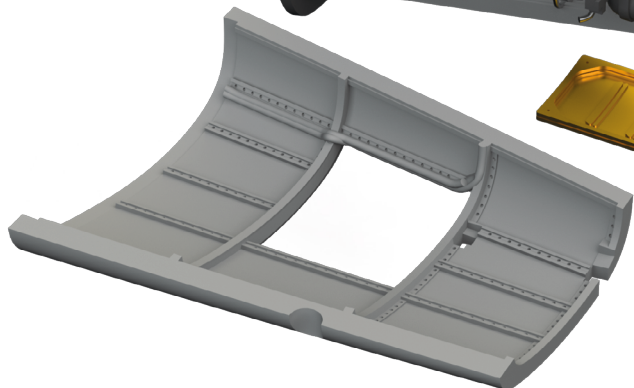
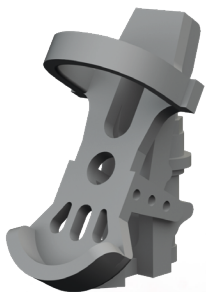

# 672344

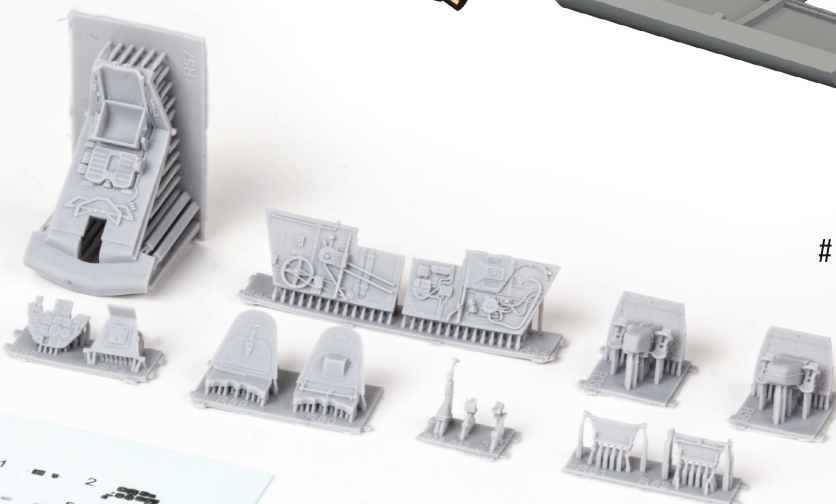

# 672347

