

Bf 109G-10 WNF/Diana **eduard**

1/72 Scale Plastic Model Kit

ProfiPACK
edition



item No. 70164

No other aircraft is so intimately connected with rise and fall of the German Luftwaffe during the WWII like the Messerschmitt Bf 109. It became the true workhorse of the war...

The evolution of this type outlived the era in which it was designed. The Bf 109s bore the brunt of Luftwaffe duties from the opening battles of Nazi Germany through to its final downfall.

As progressive as possible

The history of the Bf 109 begins with the requirement L.A. 1432/33 issued by Reich Ministry of Aviation (RLM) in late March 1933. It called for the development of a single-engined monoplane fighter. Proposals were submitted by Arado, Heinkel, Focke-Wulf and Bayerische Flugzeugwerke. The design bureau of the last-mentioned company was led by its technical director Willy Messerschmitt, who was riding a wave of popularity based on the success of his liaison aircraft, the Bf 108. Messerschmitt's goal was to create an aircraft with the best possible performance for the specified weight and size. Over the subsequent months, several prototypes were built that served first and foremost in development flights and further modifications. The aircraft was relatively small, and compared to the prevailing trends of the time, sported several quite revolutionary features such as low wing design, retractable landing gear, wing with a thin airfoil, wing slats, landing flaps, weapons firing through the propeller hub, and so on. Even the enclosed cockpit and the method of the airframe design were not very common just four years prior to the beginning of the Second World War. At its conception, the Bf 109 was a very promising asset despite some powerplant troubles. These were solved by the introduction of the DB 601. This engine, together with its extrapolated development DB 605, is umbilically connected to the success of the Bf 109. These two-row, twelve-cylinder inverted V engines powered several tenths of thousands of 109s in over 25 versions and variants.

From Spanish War to the Reich Defence

The first combat use of Bf 109 occurred during Spanish Civil War, where three developmental Bf 109s were deployed in December 1936. The main reason of revealing the modern fighter to the world was quite down-to-earth: To validate its abilities in modern aerial combat. Shortly thereafter, production aircraft in the form of the Bf 109B-1 began to reach 2.J/88, the Legion Condor. The desire of Germany to demonstrate its aerial prowess to potential foes was advanced further in international sport meets. The triumphs attained in Zurich in the summer of 1937 were complemented several months later by grabbing the speed record of 379.63 mph (610.95 km/h). In very short order, the progressive developments represented by the C, D and E versions appeared. Despite this, the delivery of the aircraft to combat units did not sustain a rate that was desired by military brass. Even by August 1938 the Bf 109 accounted for less than half of the 643 front line fighters in service. The later months saw an increase in these rates. By the time of the invasion of Poland (which saw the participation of only

a little more than 200 aircraft) the Luftwaffe possessed the best fighter produced in continental Europe. With both a qualitative and quantitative advantage, the fighter wing of the Luftwaffe entered the Polish campaign, Blitzkrieg against the West, and the Battle for France. With one foot in the door that was the English Channel, the Luftwaffe embarked on the attacks on Britain in the summer months of 1940. Here, the first weakness of the Bf 109 emerged: The inability to carry drop tanks that would have enabled the type to effectively escort bombers to England. This was one of the factors responsible for the defeat of the Luftwaffe in the Battle of Britain. Experiences gained in 1940 led to the development of the F version prior to the spring of 1941. The elegance of the Bf 109 crested with the "Friedrich". Following a largely defensive stance over the Channel and northern France, the Bf 109F took on a more offensive role in Operation Barbarossa in the east, and in northern Africa. In later duties with the "Jagdwaaffe" during the second phase of the war in the east, and in the "Defence of the Reich" from 1943 to 1945, the Bf 109s served in the form of the G version, followed by the K. Even if it was clear the development of the Bf 109 was depleted by the end of the war, the aircraft was still able to keep pace with the foes that it encountered. Besides its primary purpose as a fighter, the Bf 109 also appeared as a fighter-bomber, reconnaissance platform, night fighter, trainer and rammjäger.

The kit: Bf 109G-10 WNF/Diana

The Bf 109G (Gustav) version was direct follow-on of the Bf 109F. The main difference was the more powerful DB 605 engine, which was the development of the DB 601. Several marks with pressurised and unpressurised cockpit were produced and the development was reaching the new stage of the Bf 109K (Kurfürst) variant. The new engine variant, the DB 605 D-2 was intended for it, but it was used by the Erla factory for the interim solution, the Bf 109G-10. It was in fact follow on of the G-14, which appeared in July 1944 as new standard type replacing the G-6. It incorporated many changes introduced during the G-6 production into one type and offered better performance thanks to MW 50 power boosting water-injection system. These aircraft began to be introduced into service from November 1944, replacing the G-6 in production not only at Erla, but also at the Mtt. Regensburg and WNF/Diana factories. The fairings behind the engine cowls were similar to those installed in Mtt Regensburg machines, but with slightly less curved lower edges. Aircraft from these factories also had a bulges at the bottom of the nose in front of the exhausts, these necessitated by the wider engine crankcase and different oil installation on the Mtt Regensburg and WNF/Diana examples. The Erla factory, on the other hand, dealt with the problem by completely changing the engine cowling. A total of 2,600 units of the G-10 version were produced, with production ceasing in March 1945.

ATTENTION



UPOZORNĚNÍ



ACHTUNG



ATTENTION



注意



Carefully read instruction sheet before assembling. When you use glue or paint, do not use near open flame and use in well ventilated room. Keep out of reach of small children. Children must not be allowed to suck any part, or pull vinyl bag over the head.



Před započítím stavby si pečlivě prostudujte stavební návod. Při používání barev a lepidel pracujte v dobře větrané místnosti. Lepidla ani barvy nepoužívejte v blízkosti otevřeného ohně. Model není určen malým dětem, mohlo by dojít k požití drobných dílů.

INSTRUCTION SIGNS * INSTR. SYMBOLS * INSTRUKTION SINNBILDEN * SYMBOLES * 記号の説明

OPTIONAL
VOLBABEND
OHNOUTSAND
BROUSITOPEN HOLE
VYVRTAT OTVORSYMETRICAL ASSEMBLY
SYMETRICKÁ MONTÁŽREMOVE
ODRÍZNOUTREVERSE SIDE
OTOČITAPPLY EDUARD MASK
AND PAINT
POUŽIT EDUARD MASK
NABARVIT**PLEASE, CHECK THE LATEST VERSION OF THE INSTRUCTIONS ON www.eduard.com**

PARTS



DÍLY



TEILE



PIÈCES



部品

P>

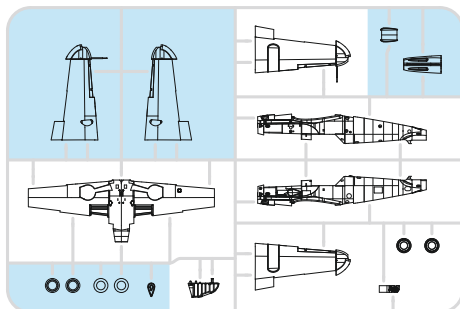

PLASTIC PARTS

U>

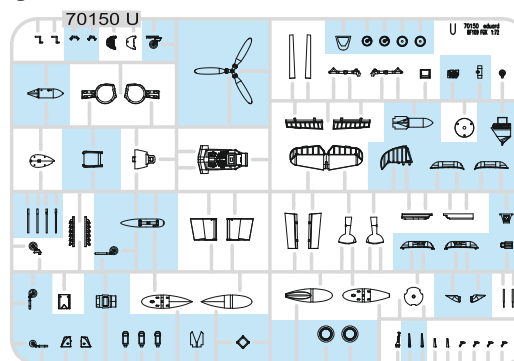

J>

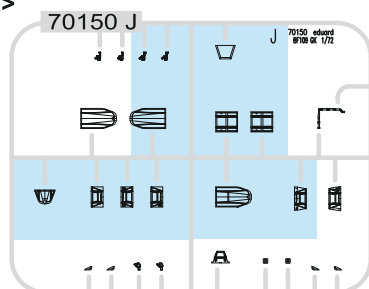

V>

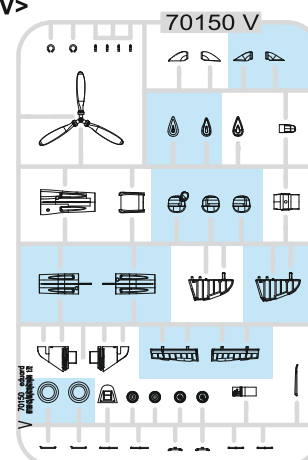

PE - PHOTO ETCHED DETAIL PARTS

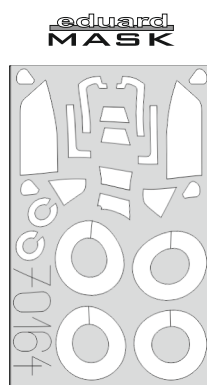
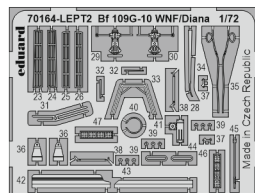
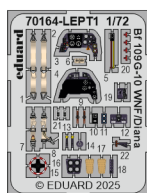

-Parts not for use. -Teile werden nicht verwendet. -Pièces à ne pas utiliser. -Tyto díly nepoužívejte při stavbě. - 使用しない部品

COLOURS



BARVY



FARBEN



PEINTURE



色

GSI Creos (GUNZE)		
AQUEOUS	Mr.COLOR	
H2	C2	BLACK
H11	C62	FLAT WHITE
H12	C33	FLAT BLACK
H43	C100	WINE RED
H47	C41	RED BROWN
H64	C17	RLM71 DARK GREEN
H65	C18	RLM70 BLACK GREEN
H68	C36	RLM74 DARK GRAY
H69	C37	RLM75 GRAY
H70	C60	RLM02 GRAY
H74	C26	GREEN BLUE
H77	C137	TIRE BLACK
H90	C47	CLEAR RED
H94	C138	CLEAR GREEN
H319	C319	LIGHT GREEN
H324	C324	LIGHT GRAY

GSI Creos (GUNZE)		
AQUEOUS	Mr.COLOR	
H413	C113	RLM04 YELLOW
H414	C114	RLM23 RED
H416	C116	RLM66 BLACK GRAY
H417	C117	RLM76 LIGHT BLUE
H421	C121	RLM81 BROWN VIOLET
H422	C122	RLM82 LIGHT GREEN
Mr.METAL COLOR		
MC213		STEEL
MC214		DARK IRON
MC219		BRASS
Mr.COLOR SUPER METALLIC		
SM201		SUPER FINE SILVER
Mr.COLOR GX		
GX05		SUSIE BLUE

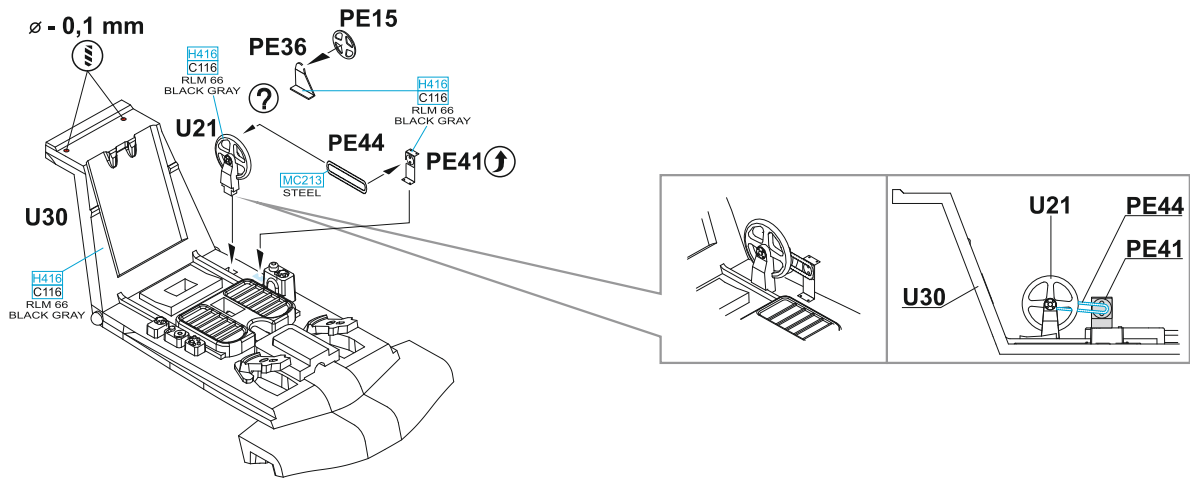

A

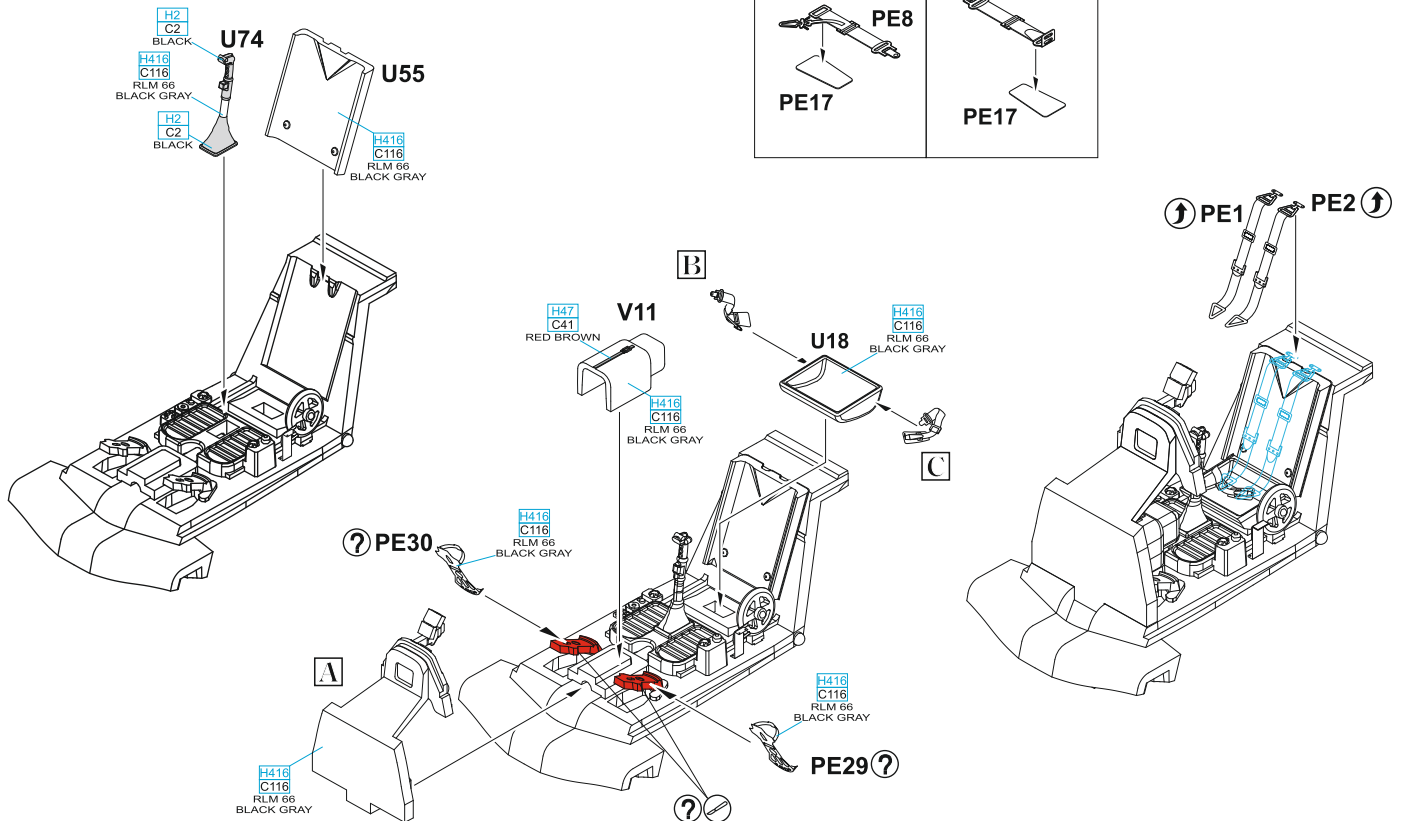
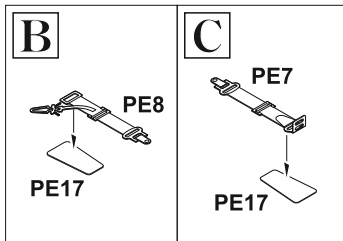
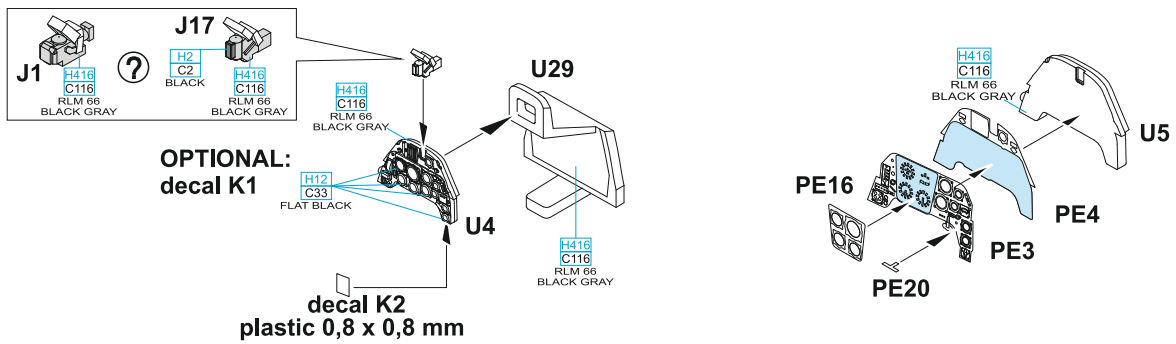

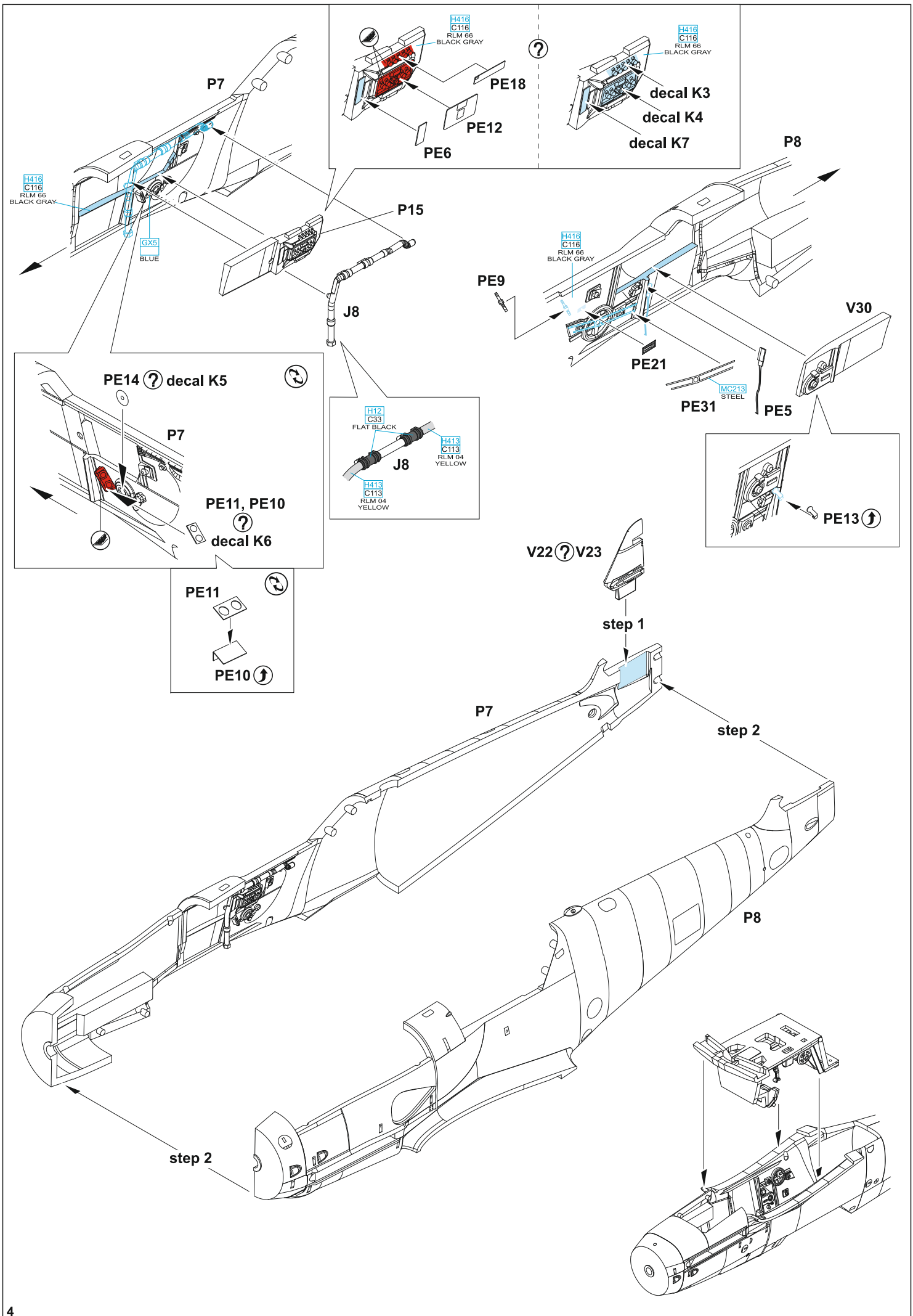

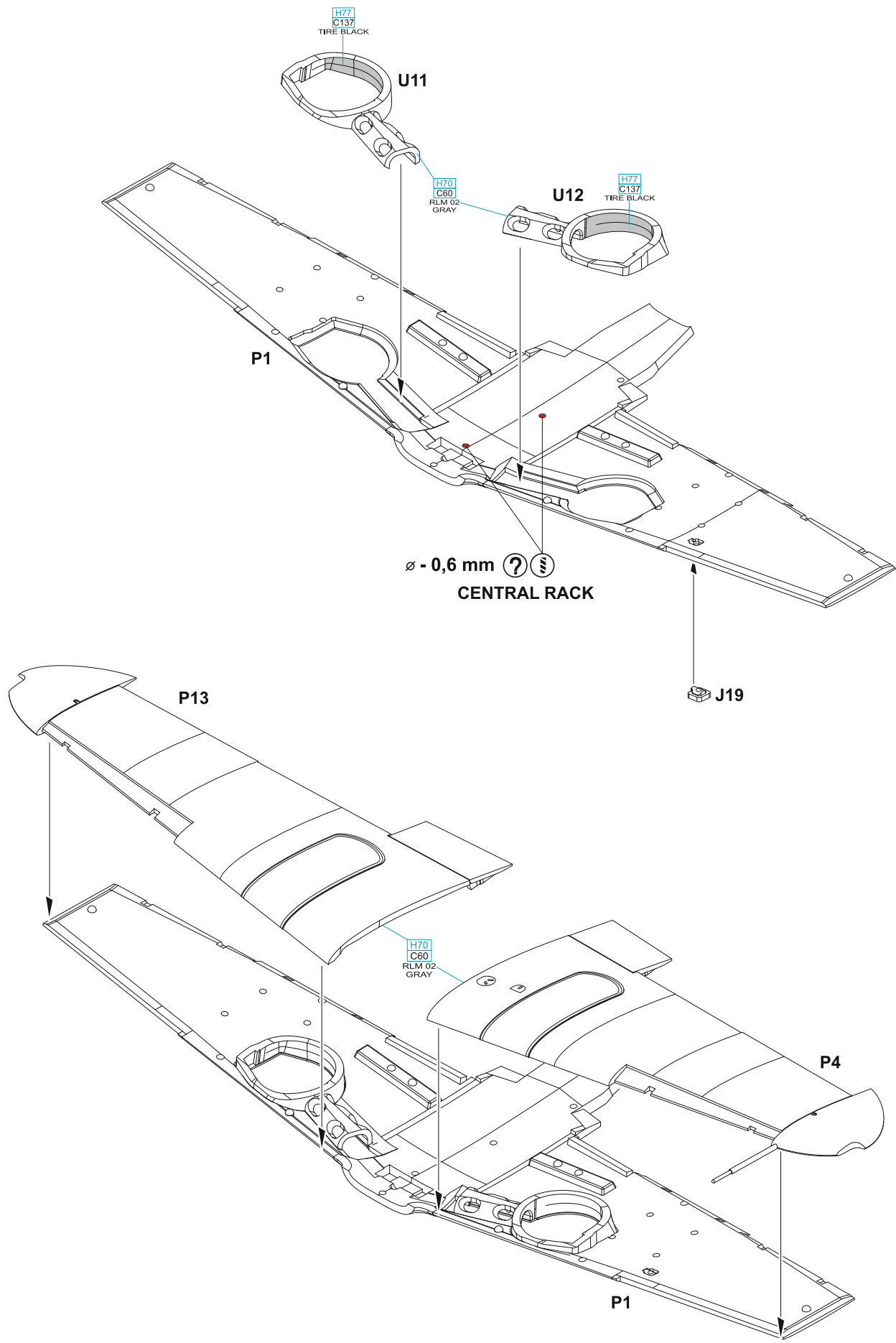

CLOSE

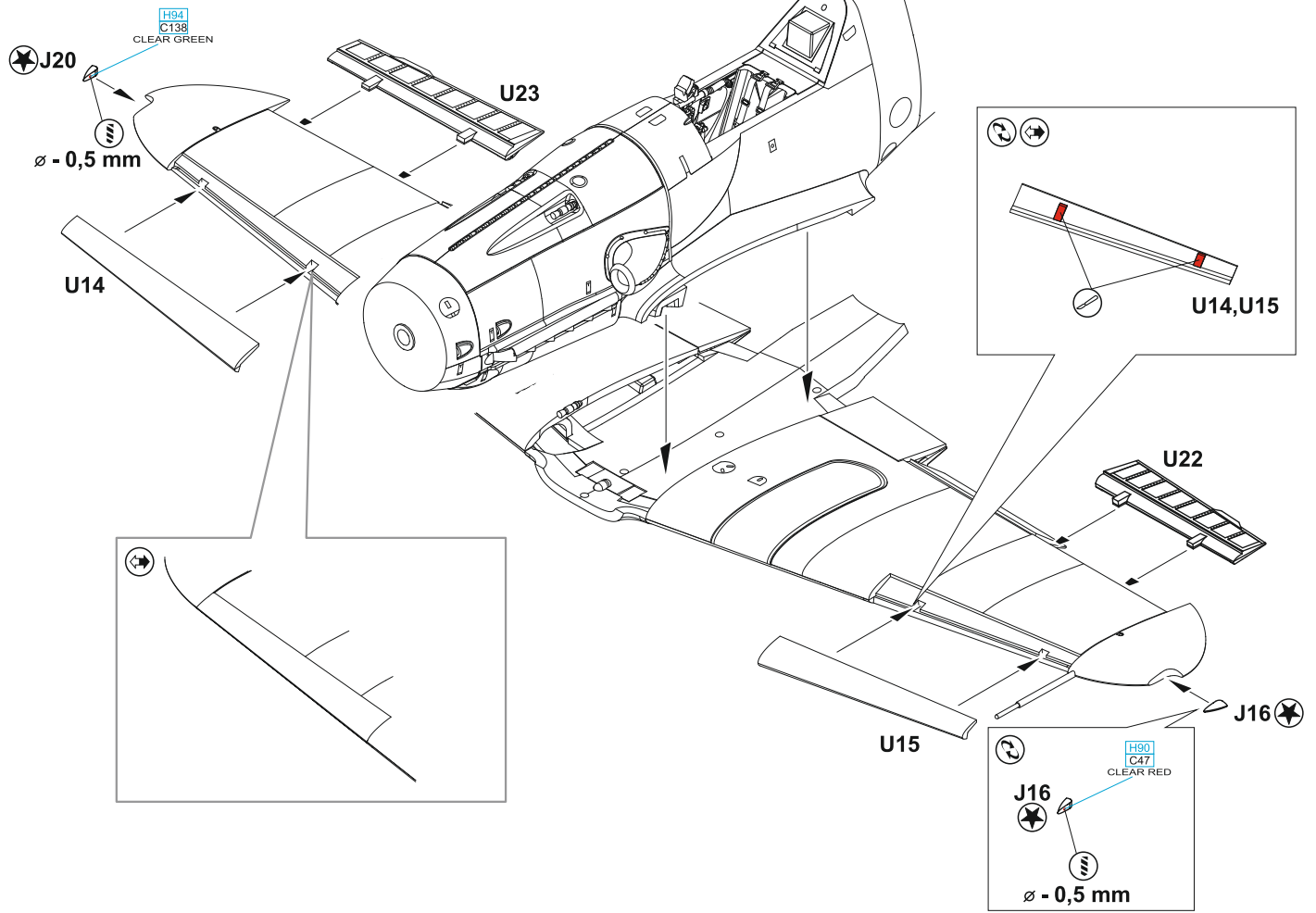

OPEN

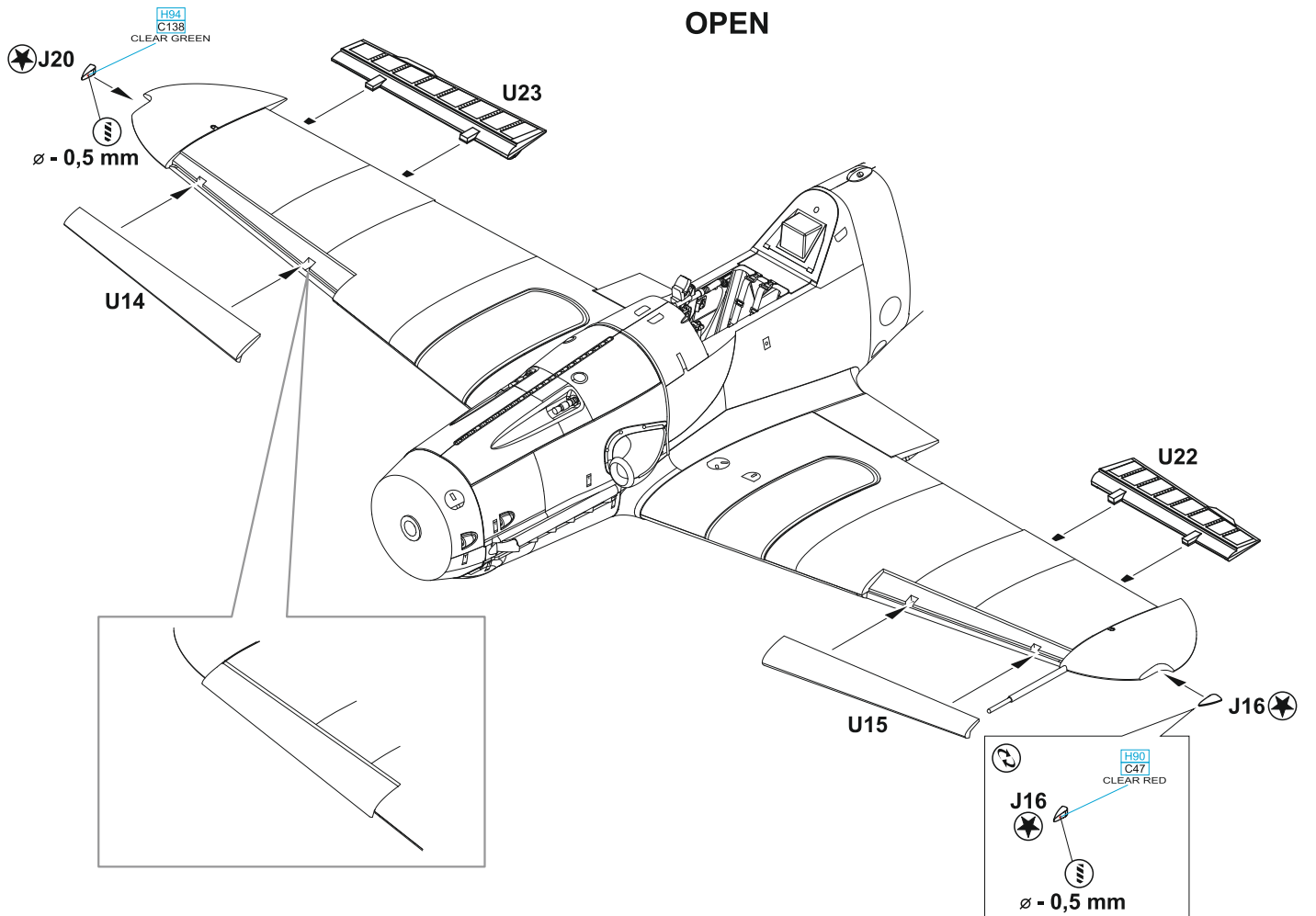

FRONT VIEW

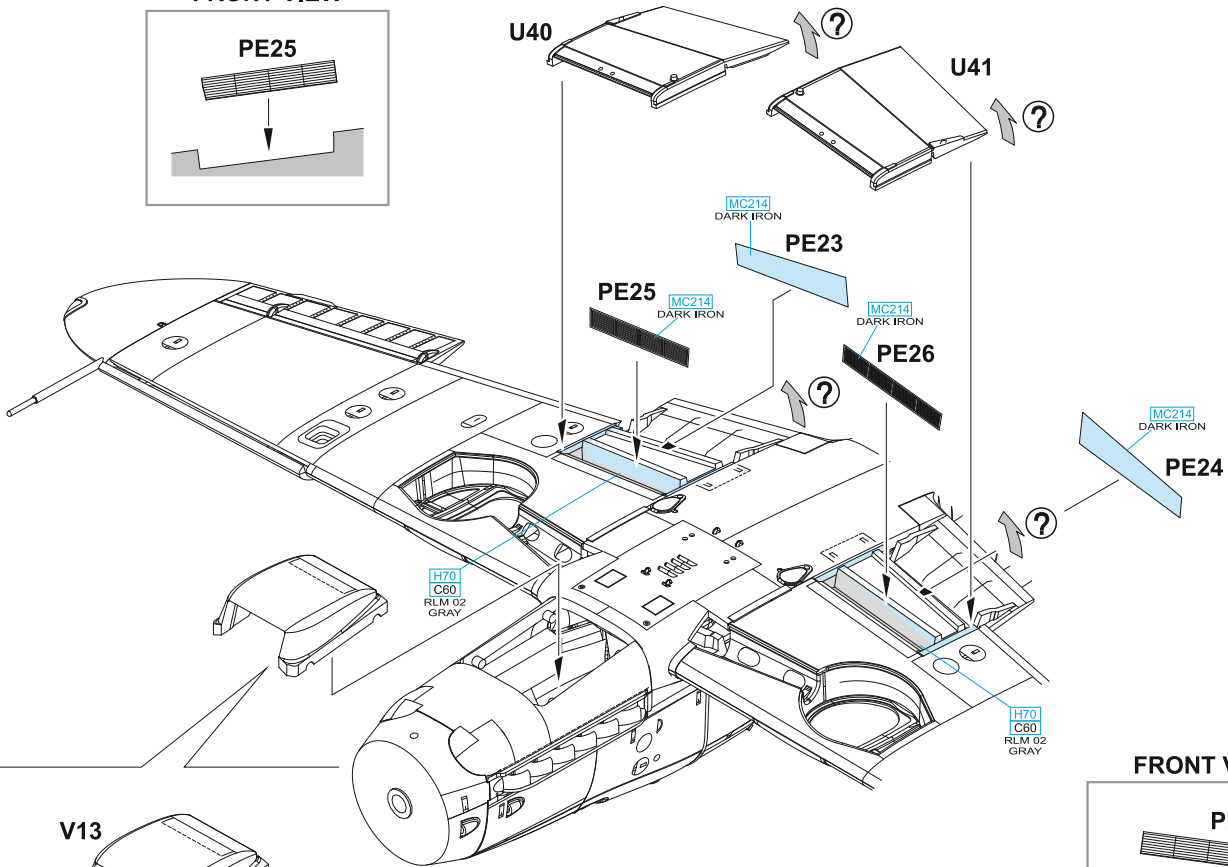
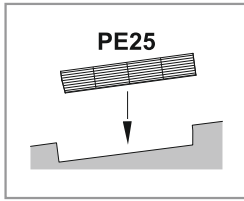

FRONT VIEW

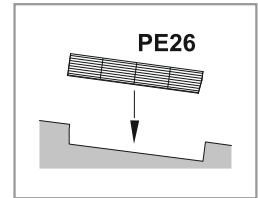

V13

H70
C60
RLM 02
GRAY

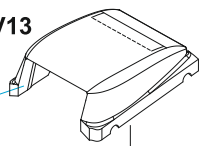

PE47

MC214
DARK IRON

PE46

MC214
DARK IRON

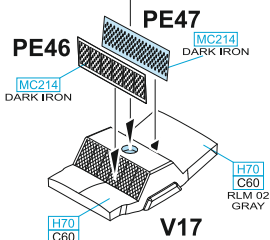

V17

H70
C60
RLM 02
GRAY

H70
C60
RLM 02
GRAY

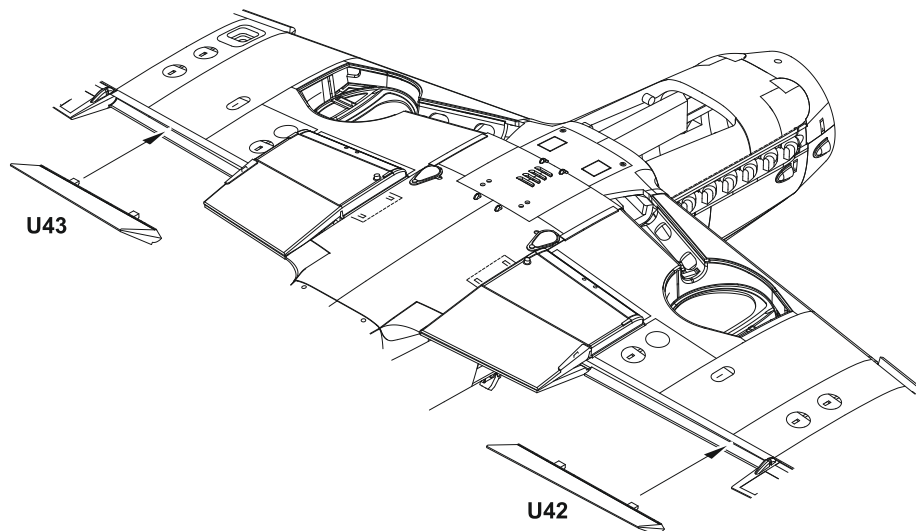

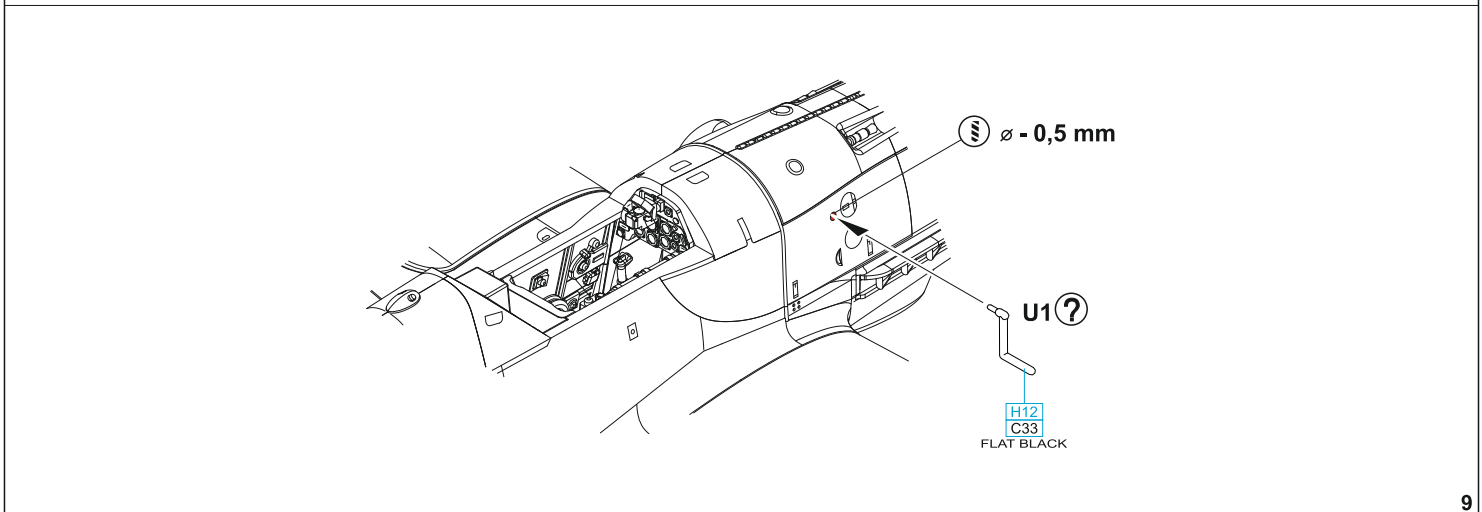
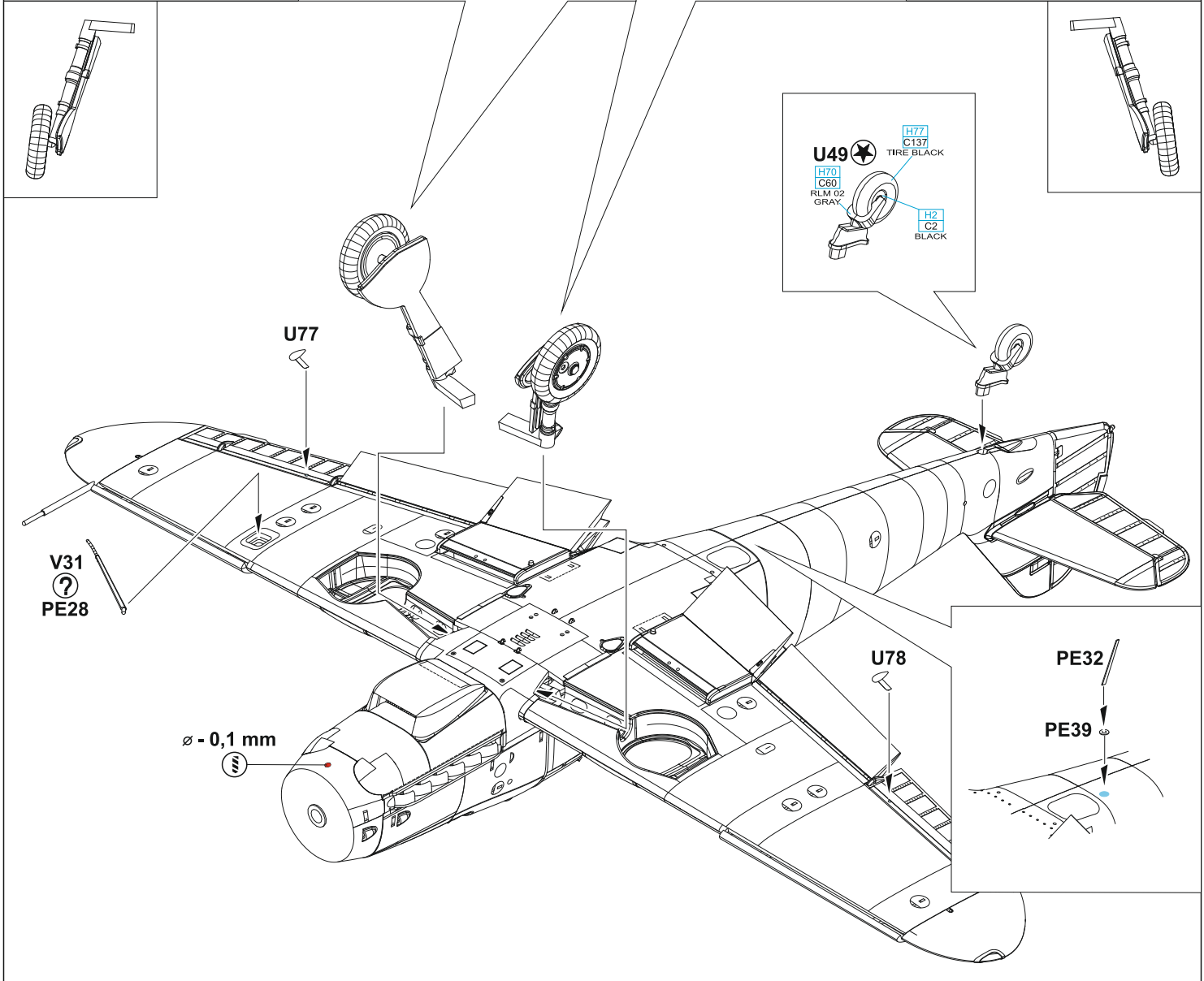
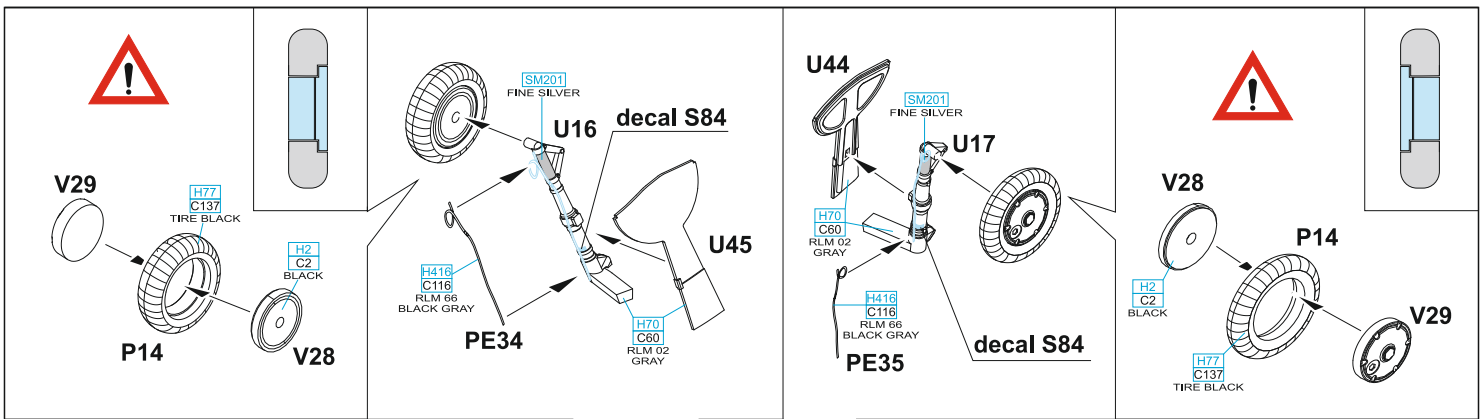

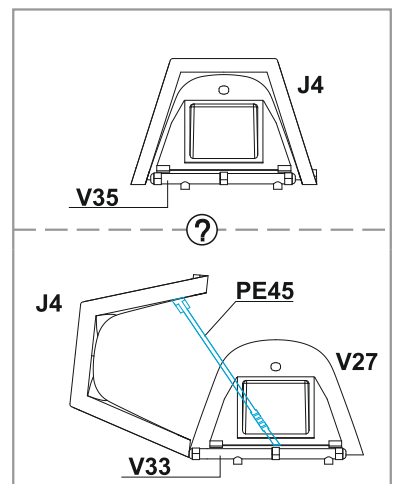
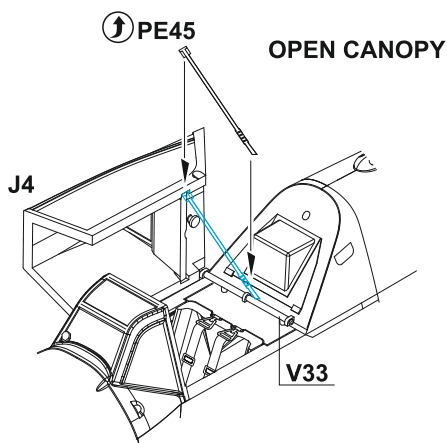
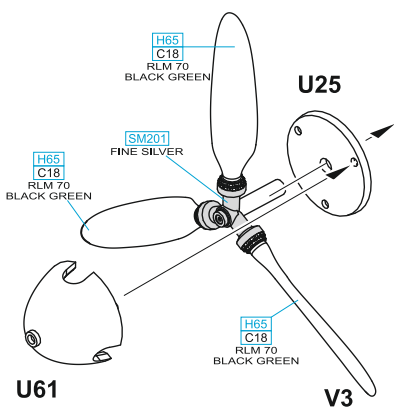
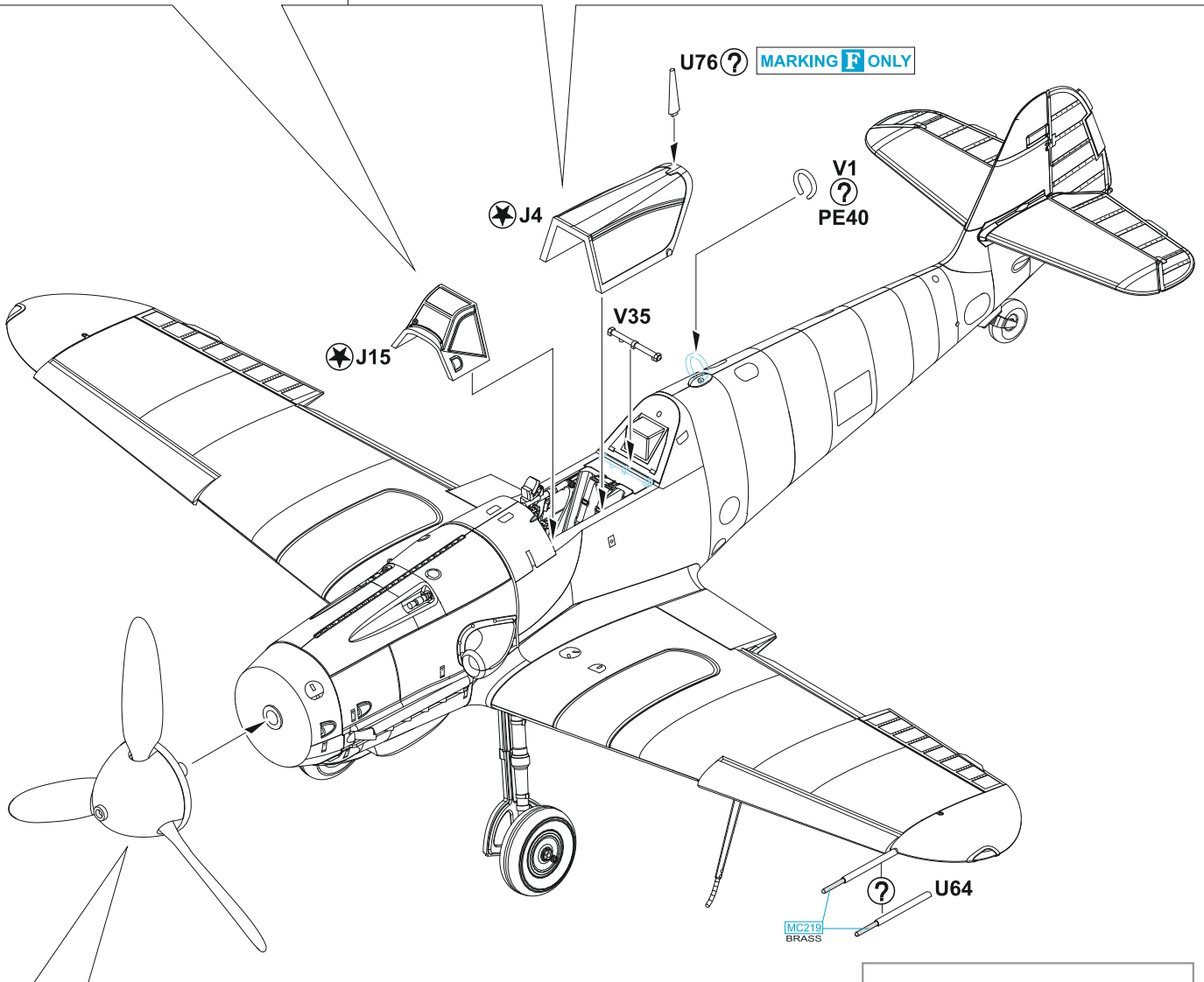
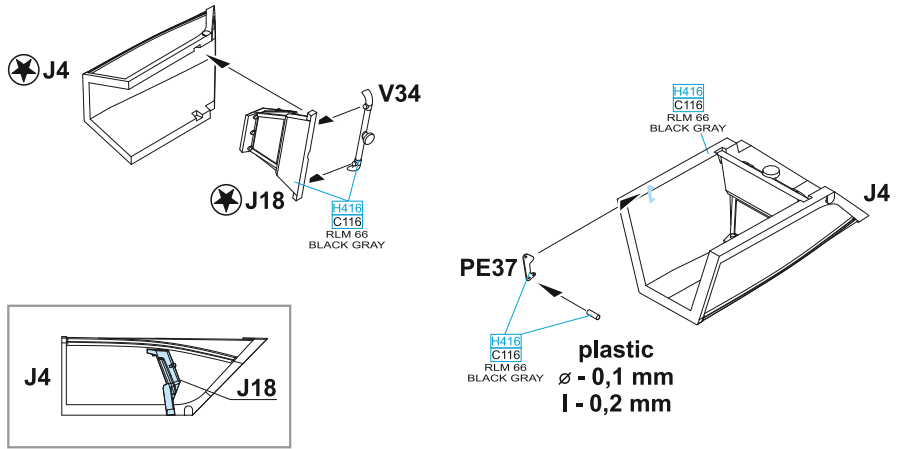
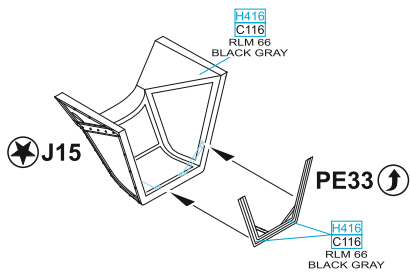

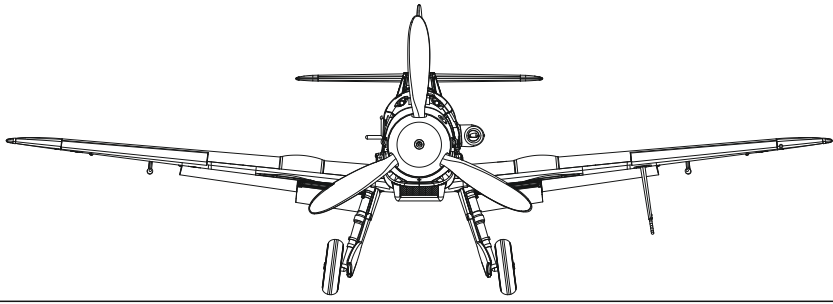
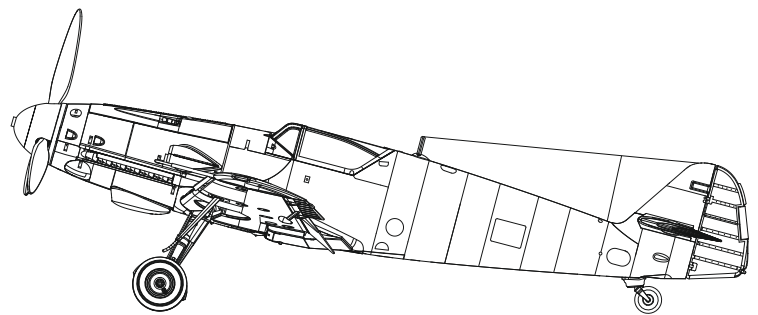
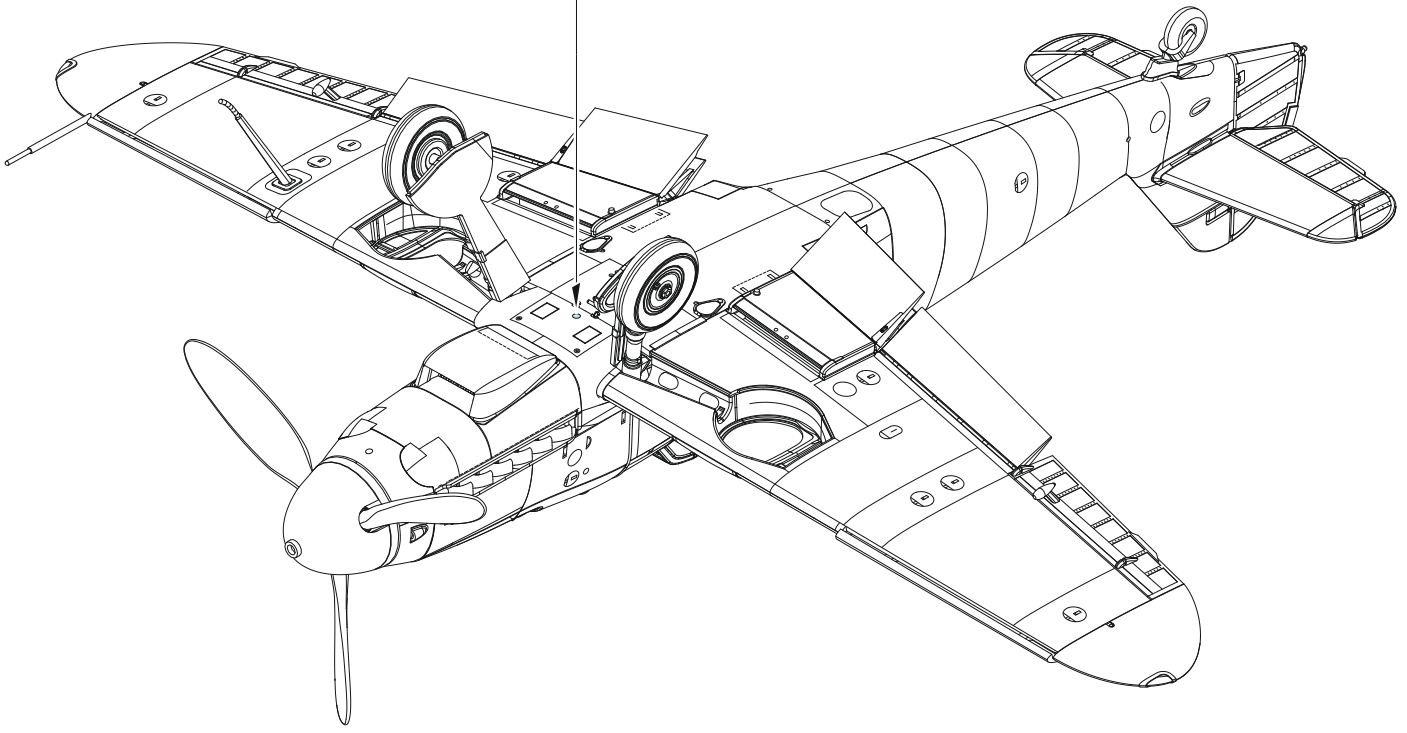
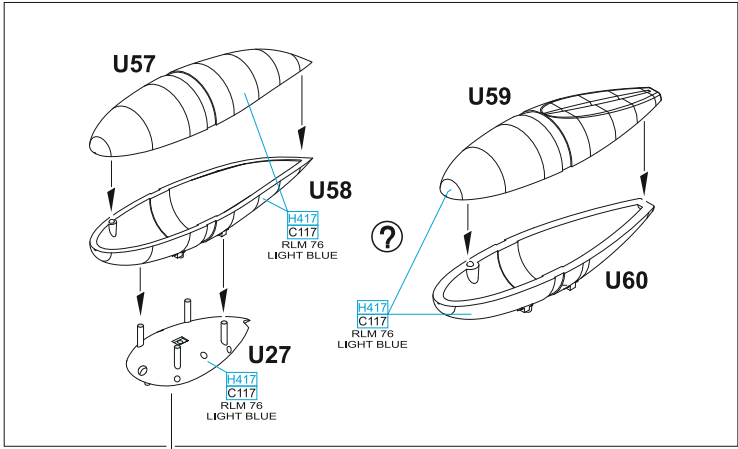

eduard
MASK

70164

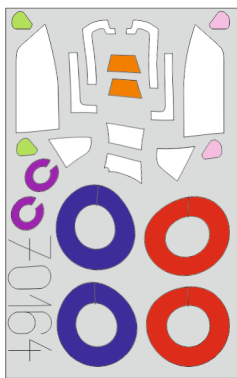
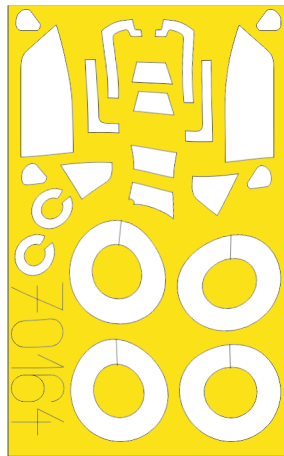

U49



P14

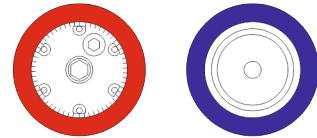

J18

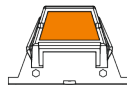

J16



J20

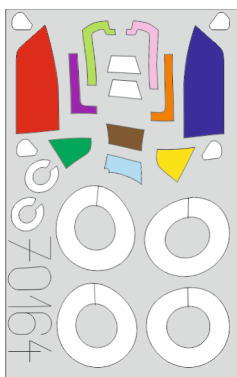

J4

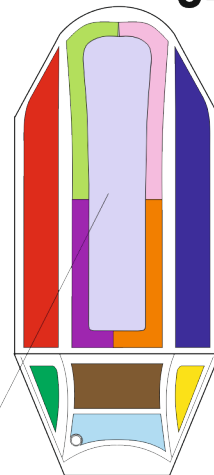

J15

LIQUID MASK



A WNr. 610487, Lt. Heinz Ewald, II./JG 52, Veszprém, Hungary, February 1945

Heinz Ewald was born on September 1, 1922, in Zoppot (Sopot), Free City of Danzig (Gdańsk). On December 1, 1941, he volunteered for military service and, after basic training with Fl.Ausb.Rgt. 23, underwent pilot training. In the fall of 1943, he was assigned to 6./JG 52 on the Eastern Front, where he often flew as a wingman to Gerhard Barkhorn. On November 12, 1943, he achieved his first aerial victory. On June 24, 1944, he suffered serious injuries, after downing a B-24 bomber near Ploiești, he was himself shot down by escorting fighters. Following his recovery, he returned in October 1944 to II./JG 52, which was then stationed in Hungary. He recorded his 50th aerial victory on January 2, 1945, and achieved five more victories the following day. In the final months of the war, he was involved in the defence of Vienna. His 84th and last victory was achieved on April 16, 1945. Four days later, Ewald was awarded the Knight's Cross. Throughout his career, he was shot down several times and earned a reputation as a lucky pilot.

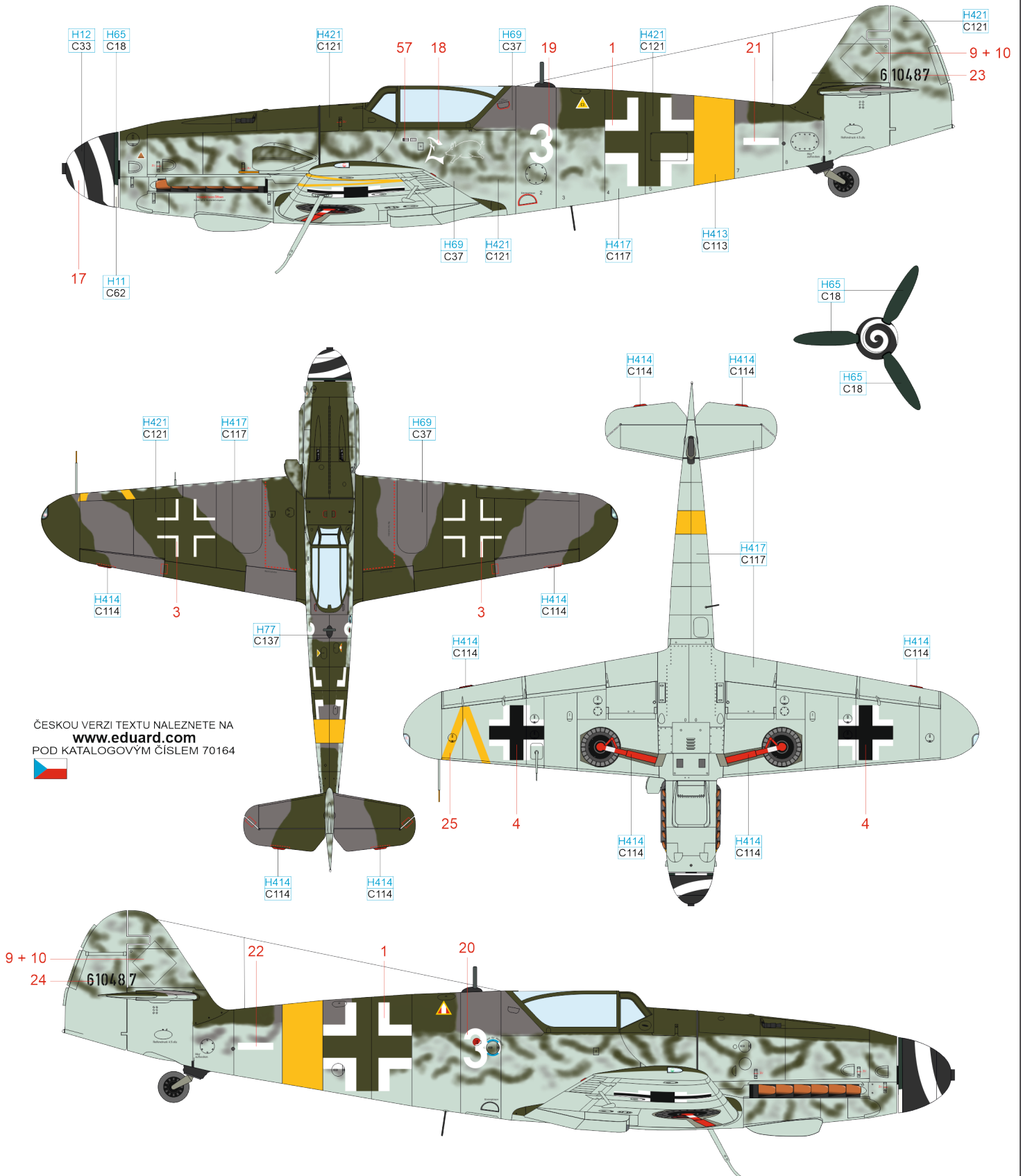

ČESKOU VERZI TEXTU NALEZNETE NA
www.eduard.com
 POD KATALOGOVÝM ČÍSLEM 70164



RLM 23	H414 C114	WHITE	H11 C62	RLM 04	H413 C113	RLM 81	H421 C121
RLM 70	H65 C18	RLM 75	H69 C37	RLM 76	H417 C117	FLAT BLACK	H12 C33
						TIRE BLACK	H77 C137

B WNr. 612769, 101. vadászezred, Neubiberg, Germany, May 1945

In the end of March 1945, the remaining Hungarian units were concentrated at Tulln airport in Austria from where they flew sorties to the areas of Vienna and Brno. After the front approached Tulln on April 5, 1945, they relocated to Raffelding airport, from where they continued in the air support of the land forces in the vicinity of Vienna. At the end of the war, the Hungarian airmen, same as their German comrades-in-arms, better surrendered to the American Army than to Soviet one, therefore the 101. vadászezred pilots flew over to the Bavarian Neubiberg with their remaining aircraft. Airframes manufactured in Diana plant were camouflaged in the same colors as the airframes from Wiener Neustadt plant. From the photographs of Red 12 it is obvious that the Hungarian national markings were spray-painted directly on the factory camouflage. The German markings were not applied at all. Part of the wing undersurfaces remained in the natural metal color.

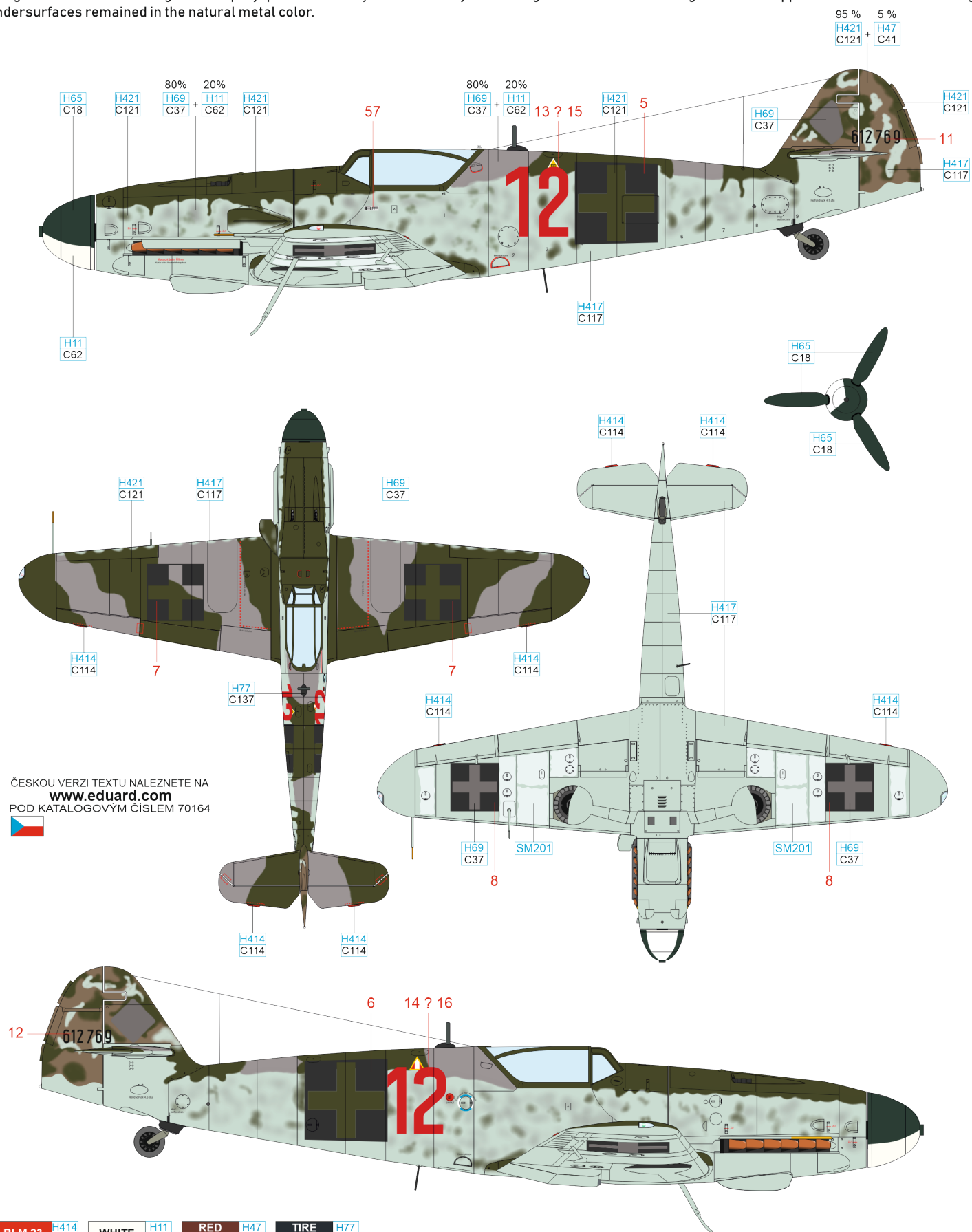

ČESKOU VERZI TEXTU NALEZNETE NA
www.eduard.com
 POD KATALOGOVÝM ČÍSLEM 70164



RLM 23	H414 C114	WHITE	H11 C62	RED BROWN	H47 C41	TIRE BLACK	H77 C137
RLM 70	H65 C18	RLM 75	H69 C37	RLM 76	H417 C117	RLM 81	H421 C121
						SUPER FINE SILVER 2	SM201

C WNr. 611975, Stab II./JG 52, Neubiberg, Germany, May 1945

The markings on this aircraft identify it as the wingman of the commander of II./JG 52, Maj. Wilhelm Batz. Batz was assigned to the staff of II./JG 52 on the Eastern Front in February 1943. He achieved his first victory on March 11, 1943, and was appointed commander of 5./JG 52 in May. By March 1944, he had achieved his 100th victory and was made commander of III./JG 52 in April. In early February 1945, he assumed command of II./JG 52, which at the time was fighting in Hungary. His final 237th victory was recorded on April 16, 1945. Five days later, he was awarded the Swords to the Knight's Cross with Oak Leaves. On May 8, 1945, Batz and his unit flew into captivity, transferring from Zeltweg in Austria to Bad Aibling in Bavaria, accompanied by a formation of Thunderbolts during the final leg of the journey. This particular aircraft was photographed at Neubiberg airfield near Munich. The pilot who flew this plane into captivity was Uffz. Anton Kellmayer (3 victories) of 7./JG 52.

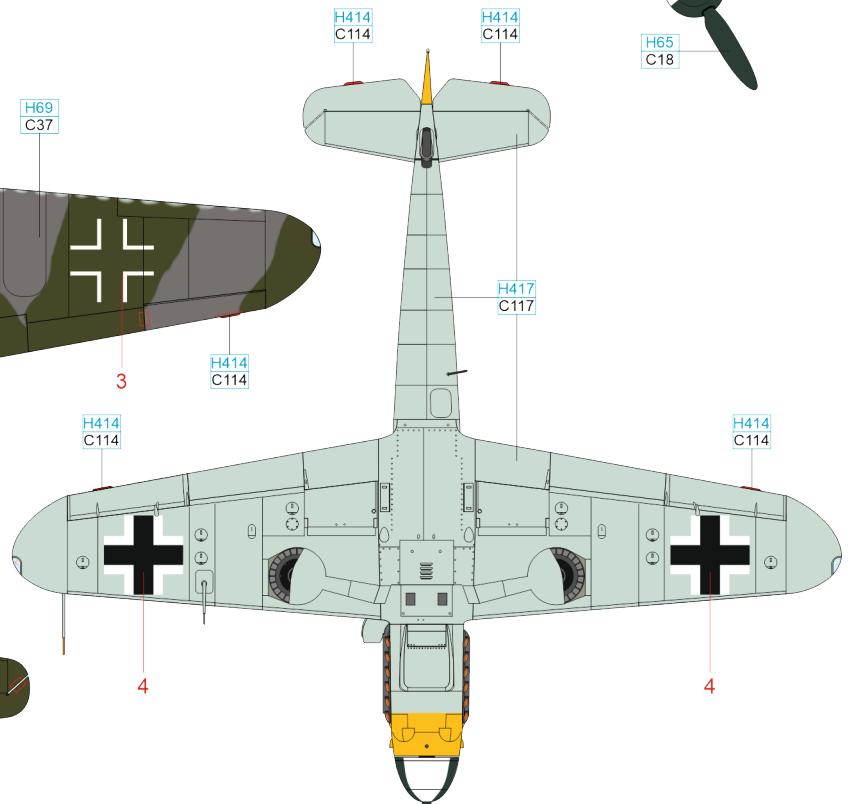
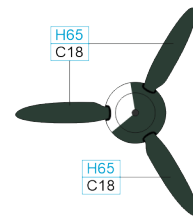
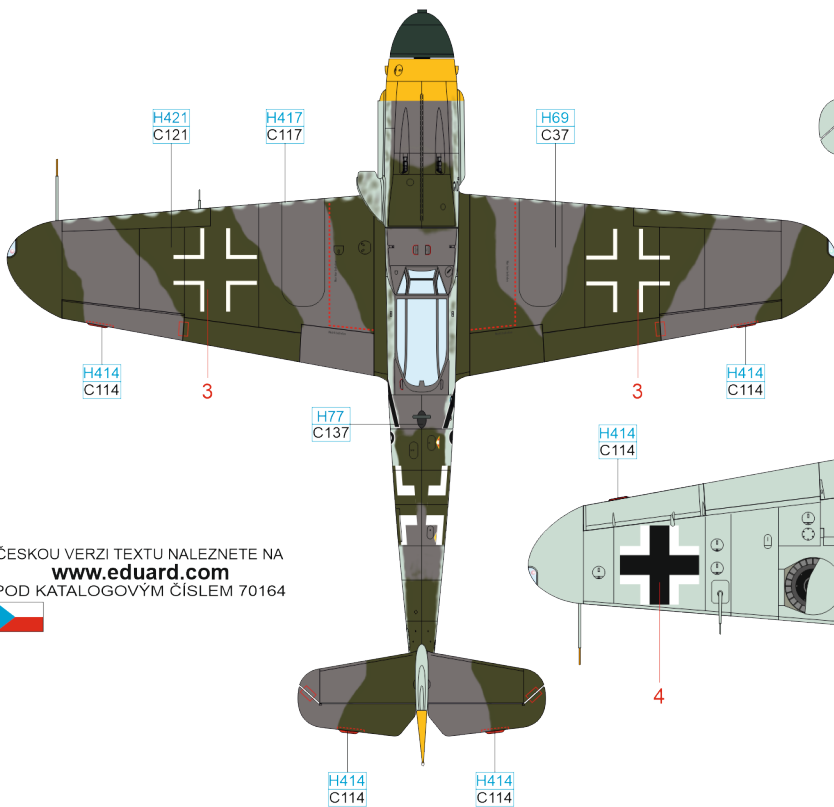
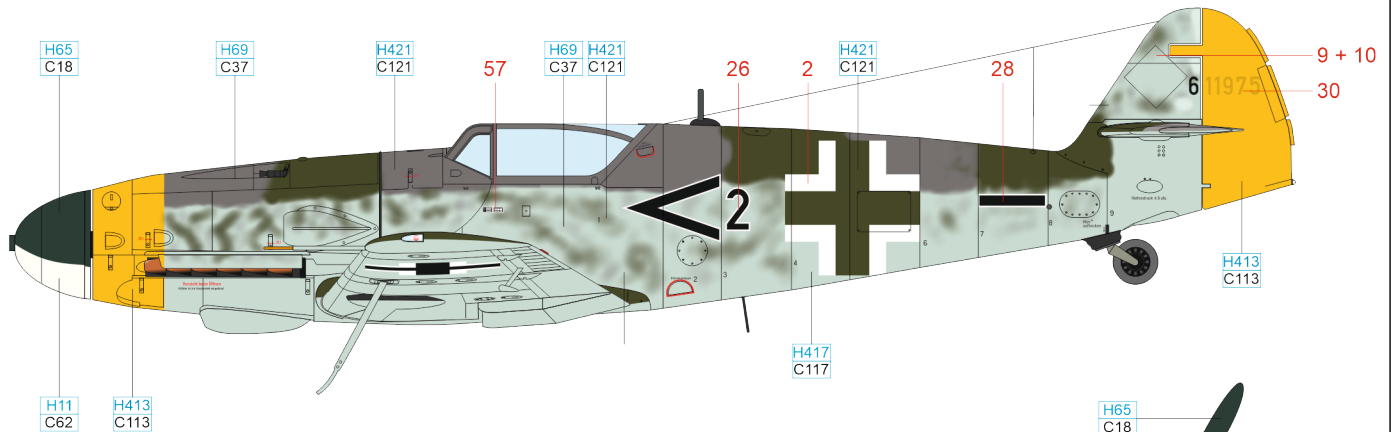

ČESKOU VERZI TEXTU NALEZNETE NA
www.eduard.com
 POD KATALOGOVÝM ČÍSLEM 70164

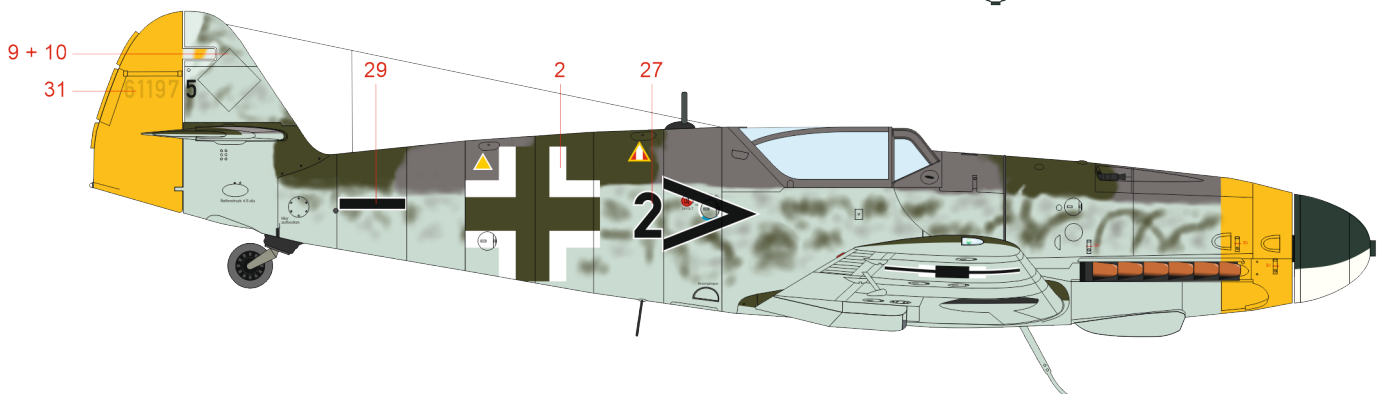

RLM 23	H414 C114	WHITE	H11 C62	RLM 04	H413 C113	TIRE BLACK	H77 C137
RLM 70	H65 C18	RLM 75	H69 C37	RLM 76	H417 C117	RLM 81	H421 C121

F Avia S-99.21, Police Air Patrol Unit, Czechoslovak Police Air Force, Prague-Ruzyně, 1947-1950

This aircraft was the last unit assembled in the spring of 1947 at the Avia factory in Čakovice. After test flights and inspections, it was located at Ruzyně Airport in mid-July 1947, where it served with the Czechoslovak Police (SNB) Air Force until the summer of 1950 (with a one-and-a-half-year break for repairs following a crash). From mid-December 1947, the Czechoslovak Police Air Force was renamed to the Aviation Security Corps of the Ministry of the Interior (BL, Bezpečnostní letectvo ministerstva vnitra). The aircraft was painted steel gray on the upper and side surfaces, with the undersides coated in a darker gray color. The aircraft operated by the SNB/BL patrols had engine cowlings, wing leading edges, and horizontal stabilizers, including elevators, painted scarlet red. Registration markings on the sides of the fuselage and on the upper and lower wing surfaces were applied in the same red color with a white outline. The national insignia took the shape of a rounded triangle, which was standard for Police Air Patrol Unit. On this particular Avia, the insignia lacked the white outline.

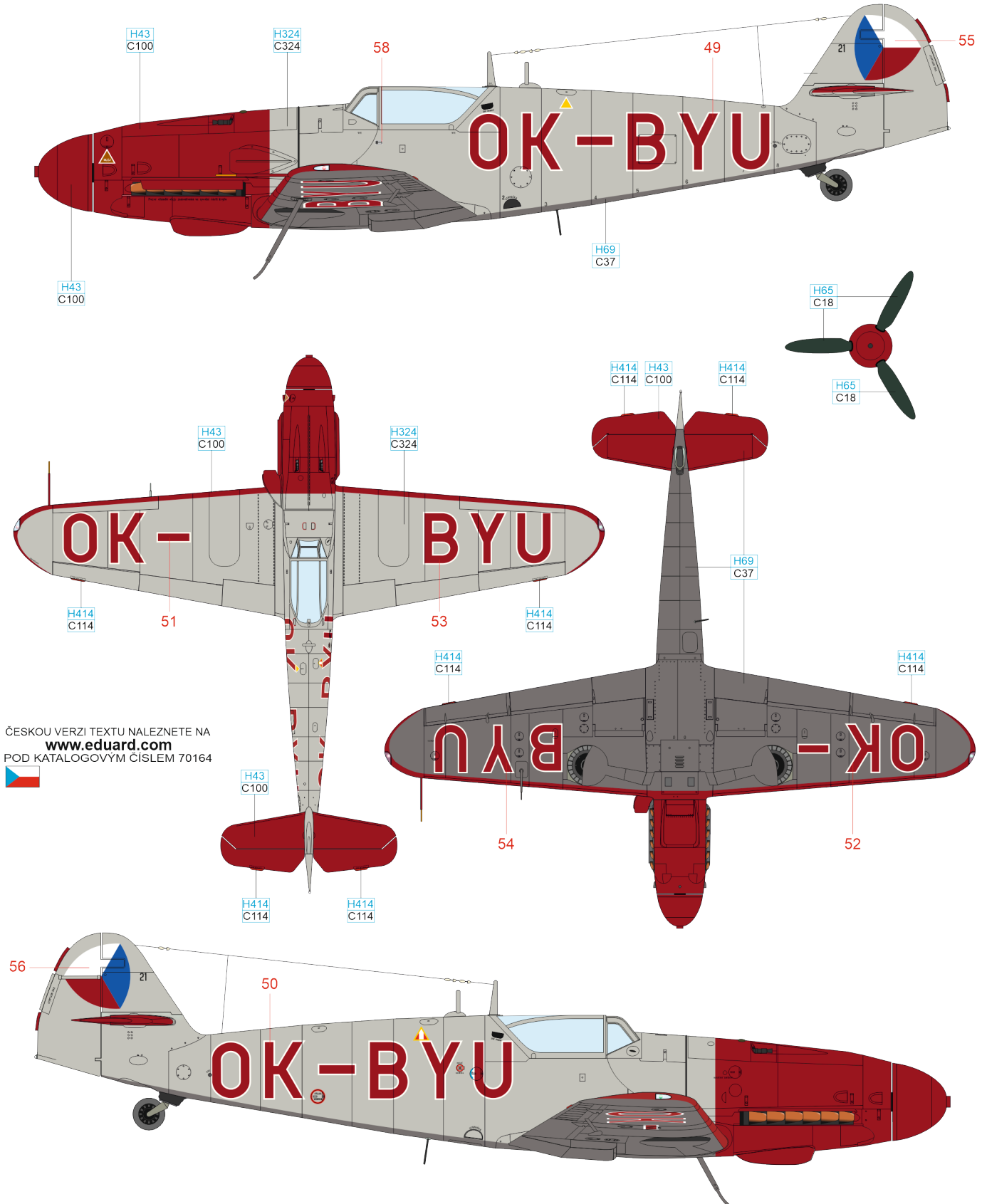

ČESKOU VERZI TEXTU NALEZNETE NA
www.eduard.com
 POD KATALOGOVÝM ČÍSLEM 70164



LIGHT GRAY	H324 C324	RLM 75	H69 C37	WINE RED	H43 C100	RLM 70	H65 C18	RLM 23	H414 C114
------------	-----------	--------	---------	----------	----------	--------	---------	--------	-----------

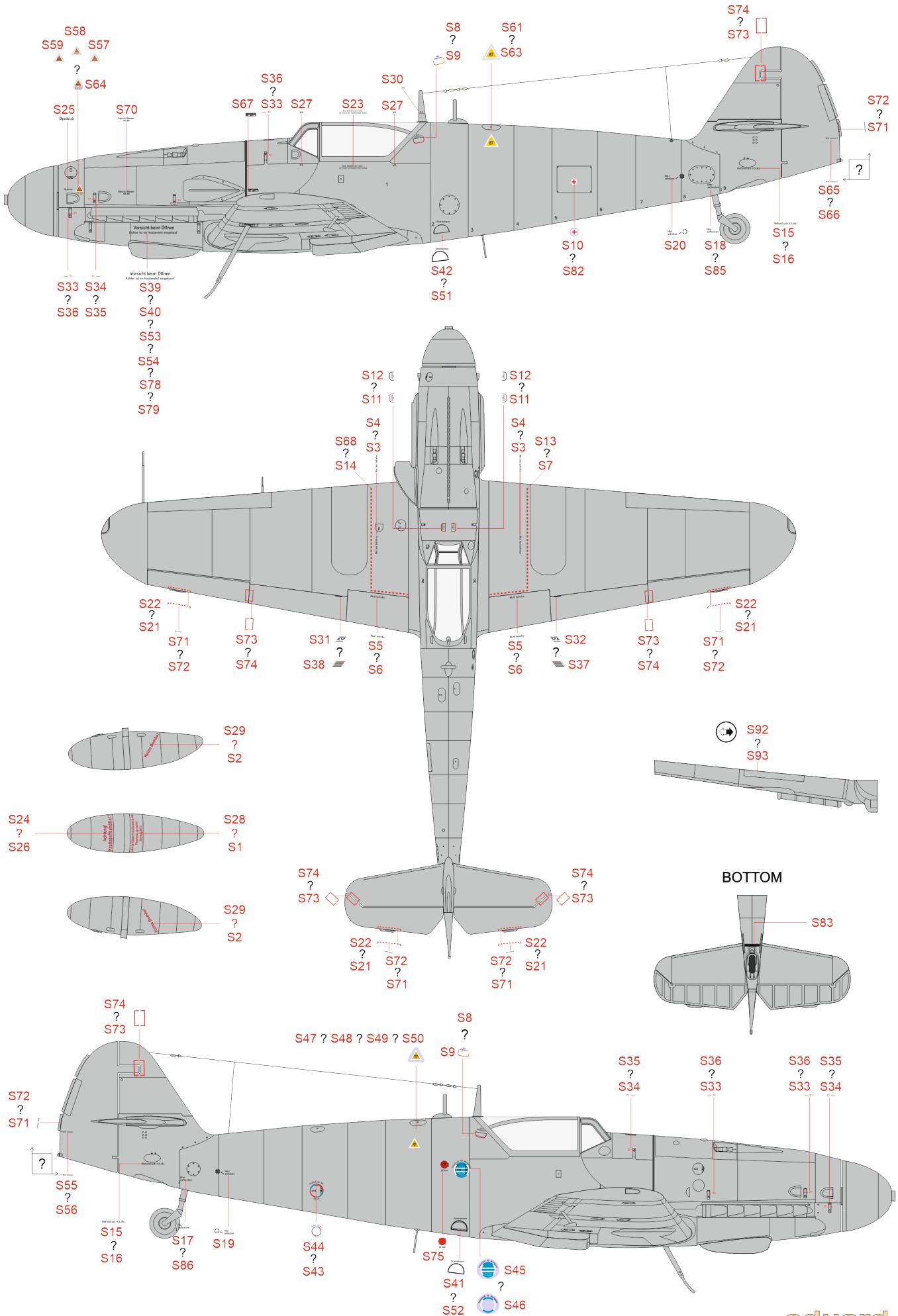

MARKING F ONLY

