

SOVIET WWII FIGHTER

1:72 SCALE PLASTIC KIT



eduard

intro

The Lavochkin La-7 was developed from its predecessor, the Lavochkin La-5. The researchers at TsAGI (Central Aero-hydrodynamics Institute) focused on aerodynamic improvements of the La-5 fighter, and tried to improve its performance in this way. The design changes appeared on an La-5 that was taken off the production line. The modified design performed very well and achieved a speed of 684 km/h at 6,150 m. Following successful tests, the Soviets decided to build another, further improved prototype.

This prototype, under the designation La-5 Etalon 1944, had its aerodynamics further refined. The major design changes were typical for the later La-7 fighter. They consisted of relocating the supercharger inlet from the lower cowling to the leading edge wing roots. The oil radiator was moved from the upper cowling to a new position under the central fuselage. The size of the radiator flaps was also reduced. Another step taken was the improvement of aerodynamics of internal structures.

The performance of the Etalon 1944 was welcomed by the Soviet armed forces, and the aircraft was accepted for production under the designation La-7. The first aircraft were manufactured by Plant No. 21 at Gorkiy in May, 1944. Production was launched at Plant No. 381 in Moscow and Plant No. 91 in Ulan-Ude consequently.

The Soviet air force obtained its first La-7s in June 1944, with operational testing under combat conditions performed by personnel of the 63rd GIAP in September and October, 1944. The tests yielded outstanding flying characteristics of the new fighter, but also its weaknesses. Very frequent defects of the hydraulic system and engine seizing were the most noteworthy. The latter problem was the result of the relocation of the supercharger inlets, as the propeller blades blew dust into it easier than before, leading to frequent seizure.

In June 1944, testing of a heavily armed La-7 took place. The two 20mm ShVAK cannons were replaced by three Berezin B-20 cannons of the same caliber. However, the new weapon was not tested properly and was prone to jamming as the heavily armed La-7 entered production. Production of the La-7 ceased in the fall of 1945, and totaled 6,158 aircraft, including 368 three-cannon versions built at Plant No. 381.

The next development steps included the experimental La-7TK with two superchargers and was developed to intercept high-altitude recce Ju 388s, but never entered production. The La-7R had a RD-1 rocket engine mounted in its tail. The aim of this experimental machine was to increase speed, but the project stopped in the prototype phase as the brand new and faster La-9 fighter was about to go into production.

A limited series of two-seat La-7UTI was manufactured as well. Huge problems with the aircraft's handling qualities resulted in La-7 pilots using the older La-5UTI for training.

The Lavochkin La-7 served in many Soviet fighter units, including elite Guards Fighter Air Regiments and Divisions. Many fighter aces flew the aircraft and achieved a number of aerial kills from within its cockpit, the highest-scoring of them being Ivan N. Kozhedub (65 personal kills + 29 shared).

H the CO of 4th GIAP, Lt. Col Vasily F. Golubyev, spring 1945

FOR COMPLETE PROFILE PLEASE REFER
 KOMPLETNÍ KAMUFLÁŽNÍ SCHEMA
 NALEZNETE NA
www.eduard.com/s/7066

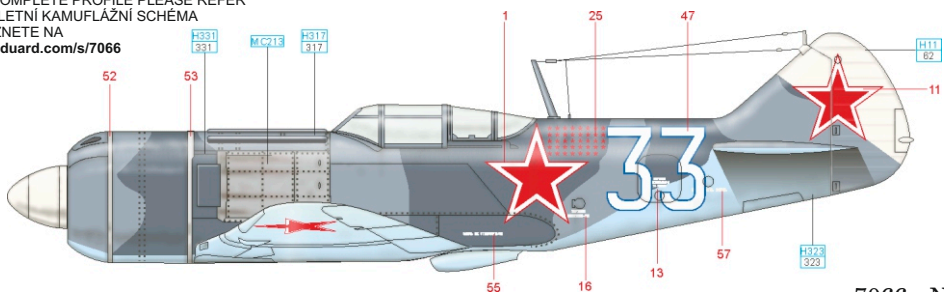



Carefully read instruction sheet before assembling. When you use glue or paint, do not use near open flame and use in well ventilated room. Keep out of reach of small children. Children must not be allowed to suck any part, or pull vinyl bag over the head.



Před započatím stavby si pečlivě prostudujte stavební návod. Při používání barev a lepidel pracujte v době větrané místnosti. Lepidla ani barvy nepoužívejte v blízkosti otevřeného ohně. Model není určen malým dětem, mohlo by dojít k požití drobných dílů.

INSTRUCTION SIGNS * INSTR. SYMBOL * INSTRUKTION SINNBILDEN * SYMBOLES * 記号の説明

- 
 OPTIONAL
VOLBA
- 
 BEND
OHNOUT
- 
 OPEN HOLE
VYVRTAT OTVOR
- 
 SYMMETRICAL ASSEMBLY
SYMETRICKÁ MONTÁŽ
- 
 NOTCH
ZÁŘEZ
- 
 REMOVE
ODRÁZNOUT
- 
 APPLY EDUARD MASK AND PAINT
POUŽÍJ EDUARD'S MASK NABARVIT

PARTS * DÍLY * TEILE * PIĘCES * 部品

PLASTIC PARTS

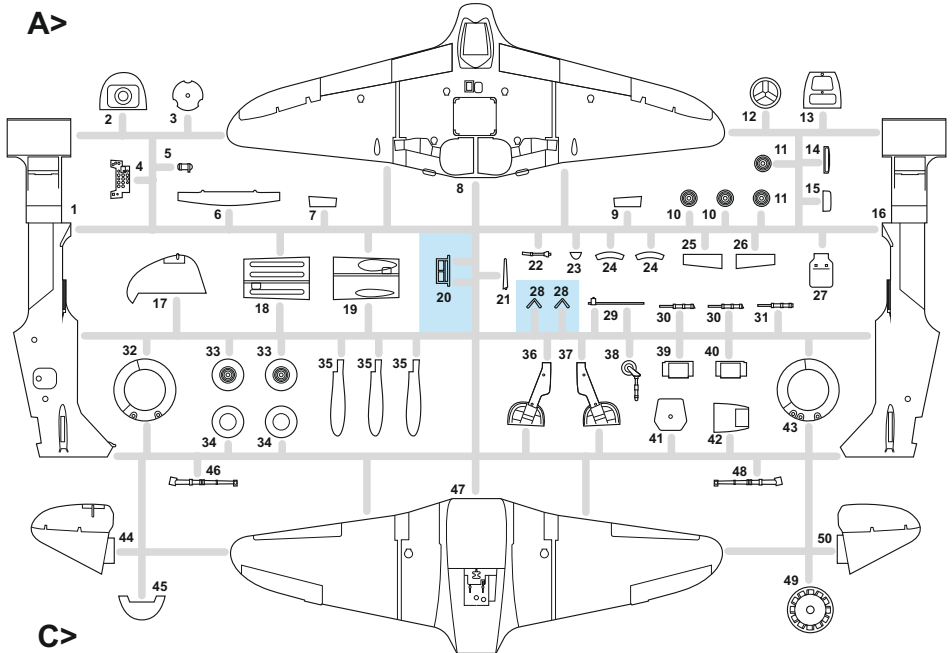

C>

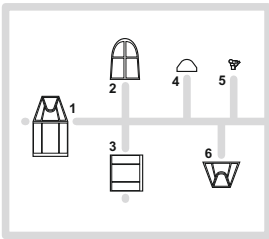

PE - PHOTO ETCHED DETAIL PARTS

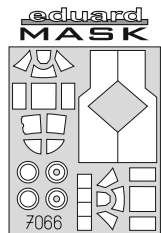
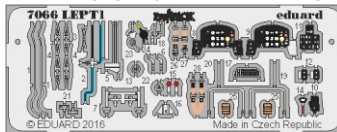

-Parts not for use. -Teile werden nicht verwendet. -Pièces à ne pas utiliser. -Tyto díly nepoužívejte při stavbě. - 使用しない部品

COLOURS * BARVY * FARBEN * PEINTURE * 色

| GSI Creos (GUNZE) | | |
|----------------------|----------|-----------------|
| AQUEOUS | Mr.COLOR | |
| H 4 | C4 | YELLOW |
| H 11 | C82 | WHITE |
| H 12 | C33 | BLACK |
| H 23 | C79 | SHINE RED |
| H 47 | C41 | RED BROWN |
| H 51 | C11 | LIGHT GULL GRAY |

| AQUEOUS | Mr.COLOR | |
|-----------------------|----------|--------------|
| H 77 | C137 | TIRE BLACK |
| H 317 | C317 | GRAY |
| H 320 | C303 | DARK GREEN |
| H 323 | C323 | LIGHT BLUE |
| H 331 | C331 | DARK SEEGRAY |

| Mr.METAL COLOR | |
|-----------------------|---------------|
| MC211 | CHROME SILVER |
| MC213 | STEEL |
| MC216 | ALUMINIUM |
| Mr. COLOR GX | |
| GX5 | SUSIE BLUE |

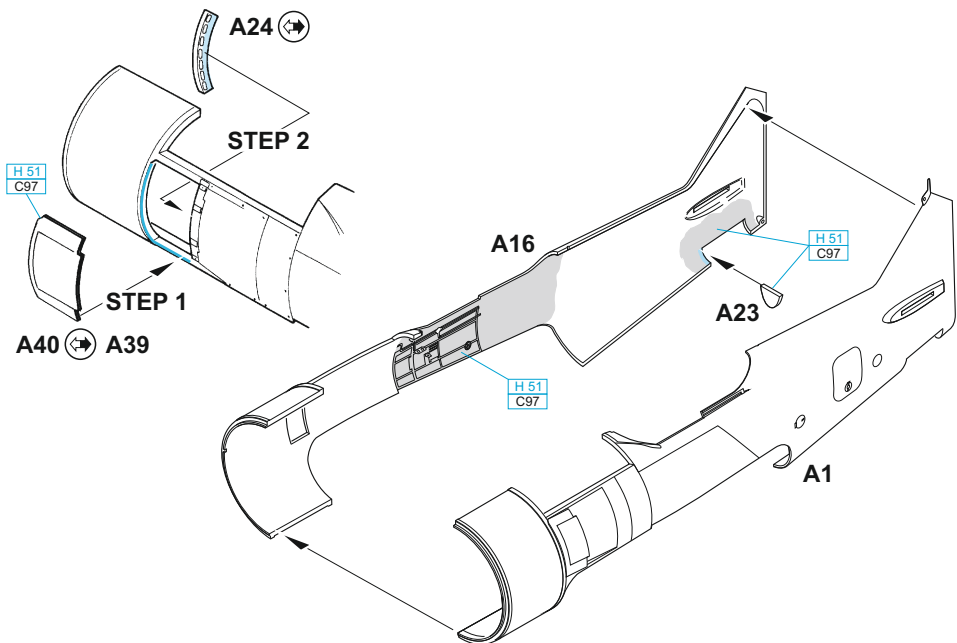
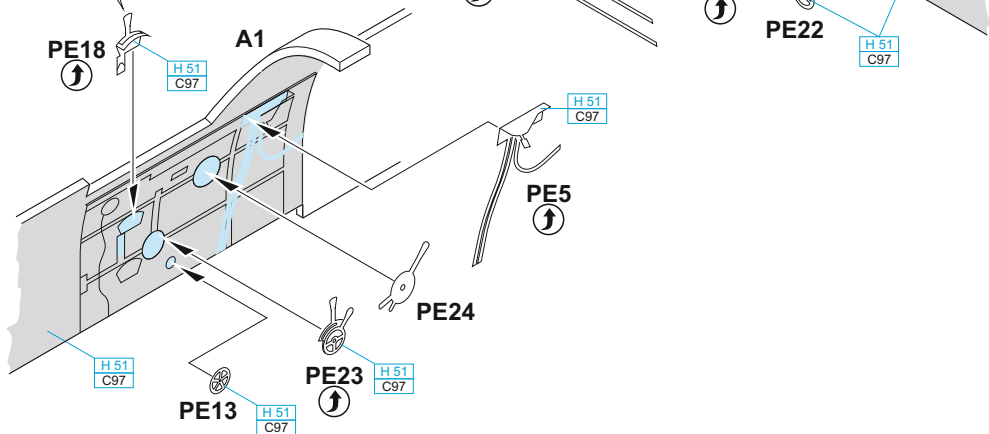
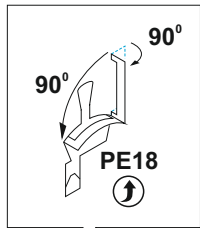

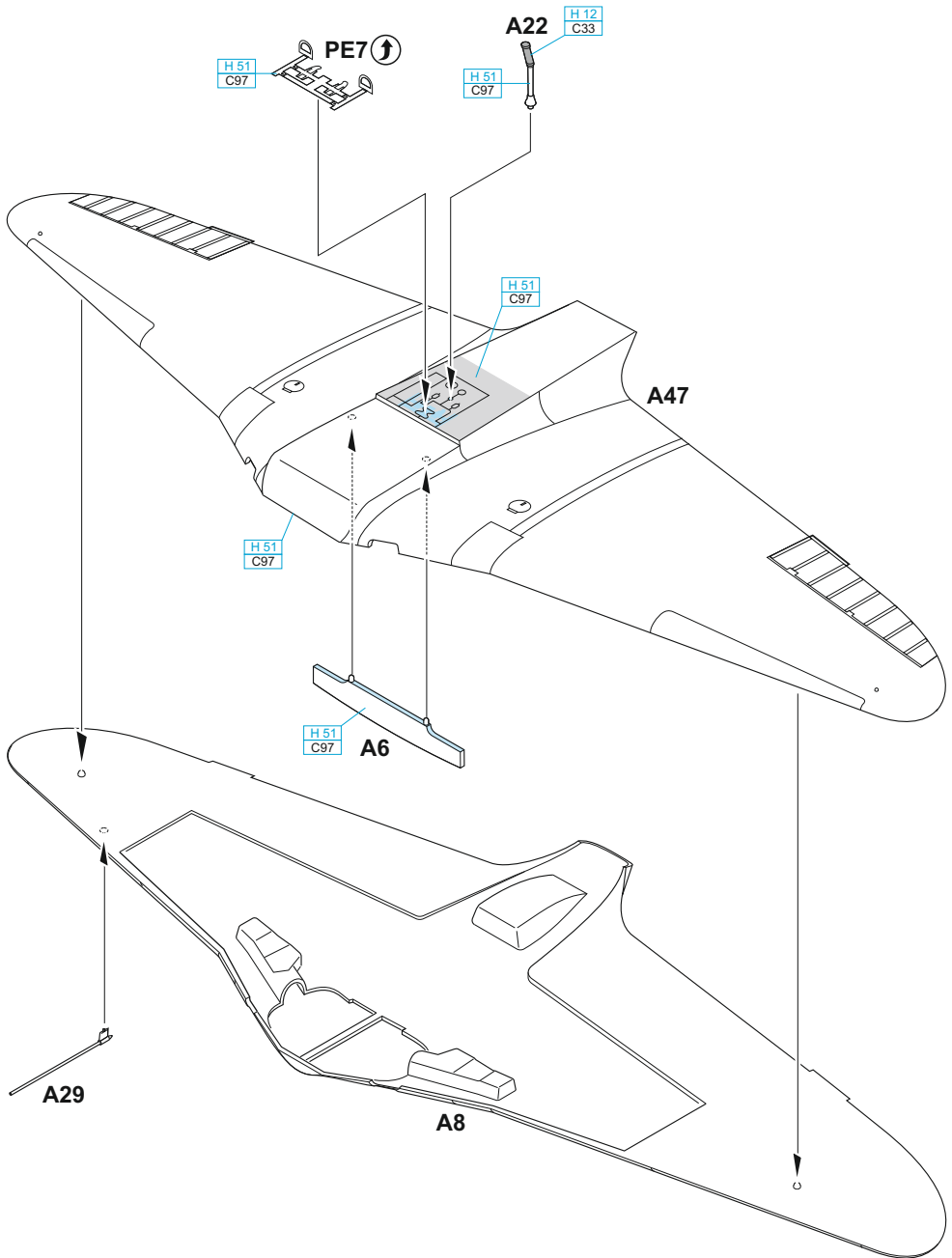

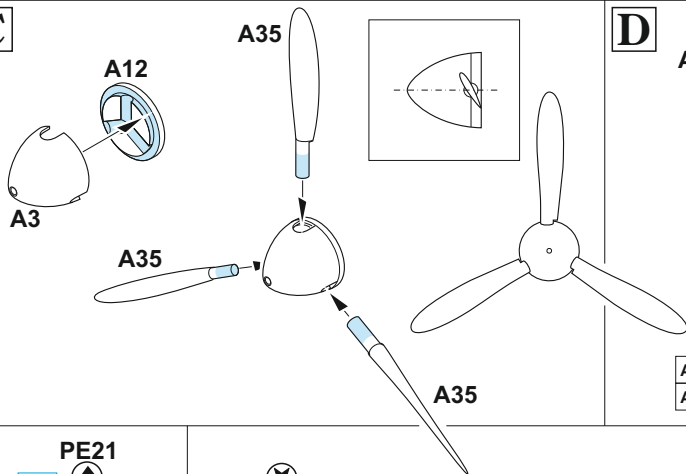
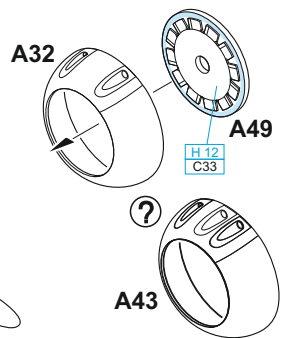
C**D**

A32 - MARKINGS **A B C D E**
 A43 - MARKINGS **F G H**

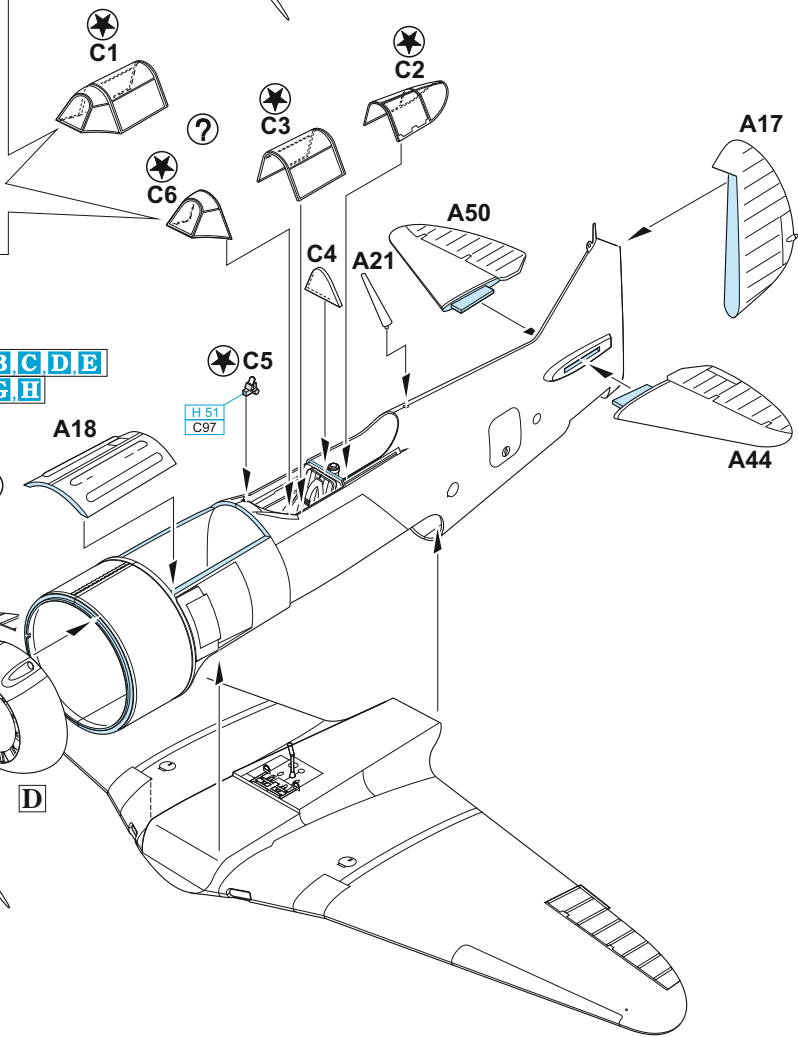
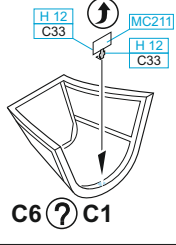
PE21

A19 - MARKINGS **A B C D E**
 A18 - MARKINGS **F G H**

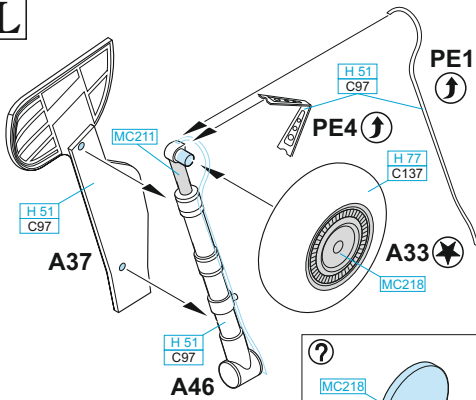
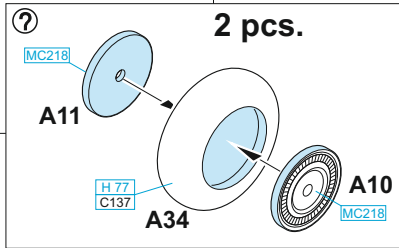
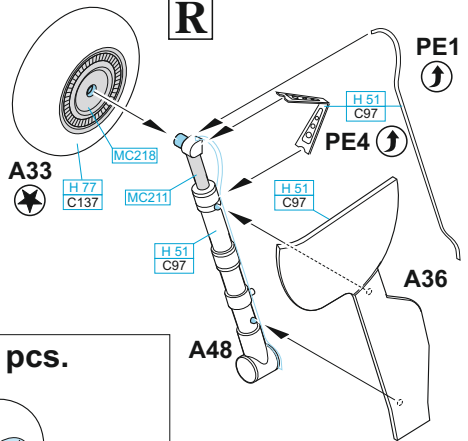
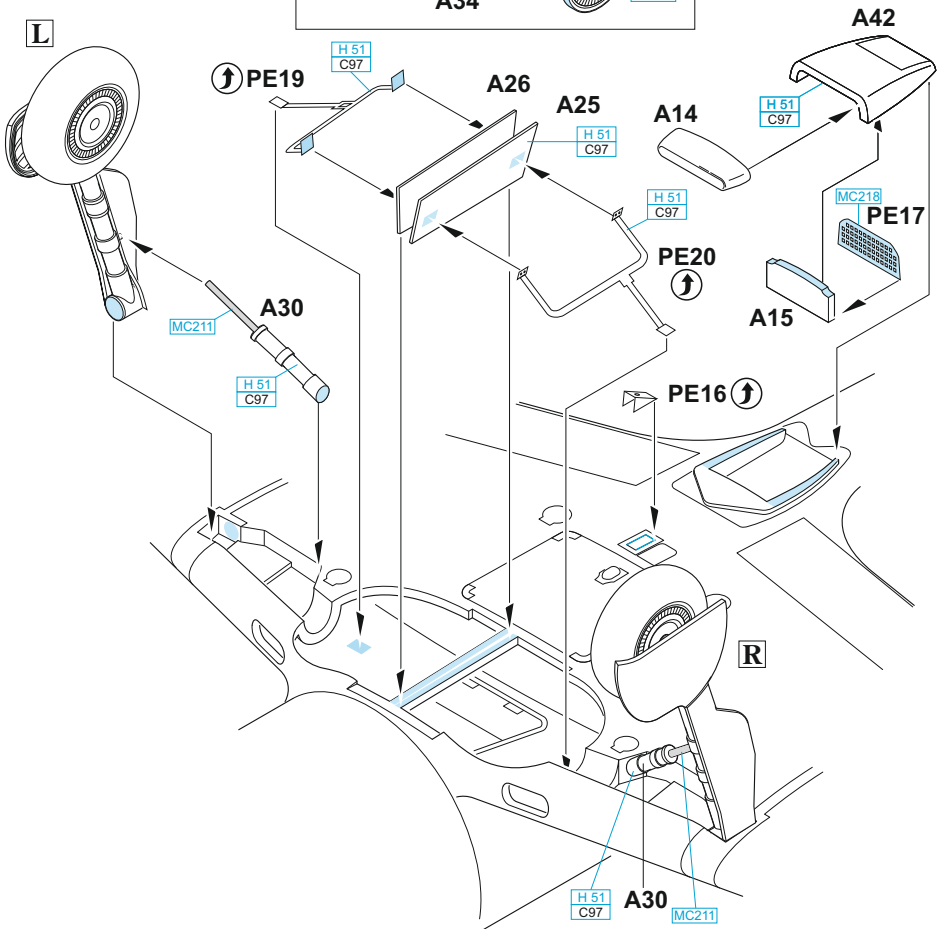
L**R****L**

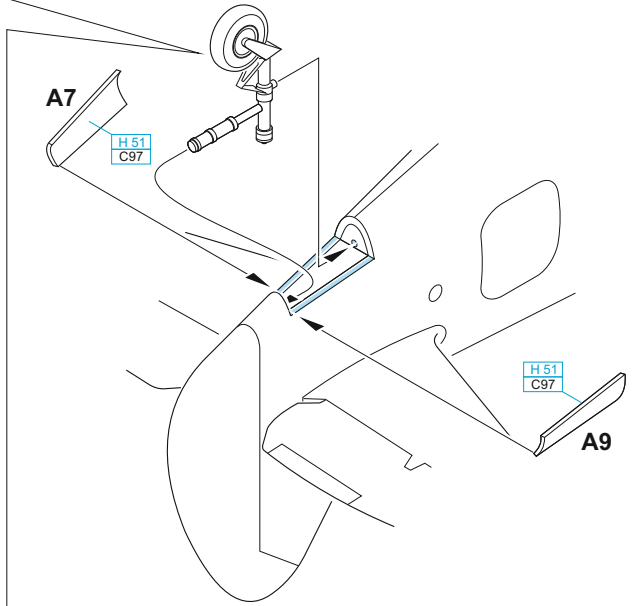
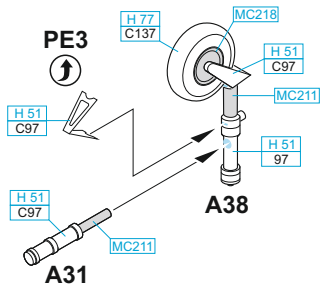

eduard
MASK

7066

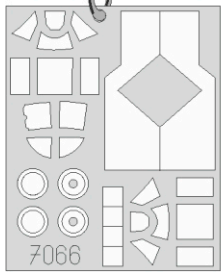

MARKING A

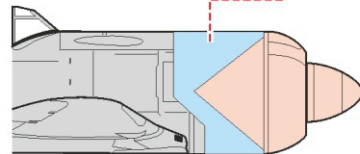
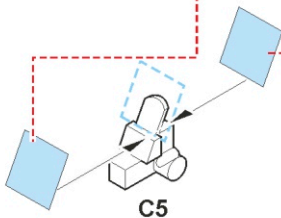
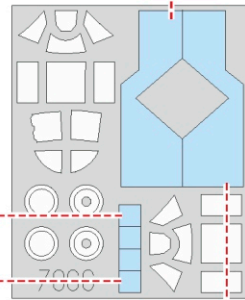
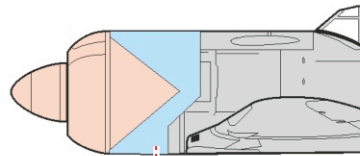

C5

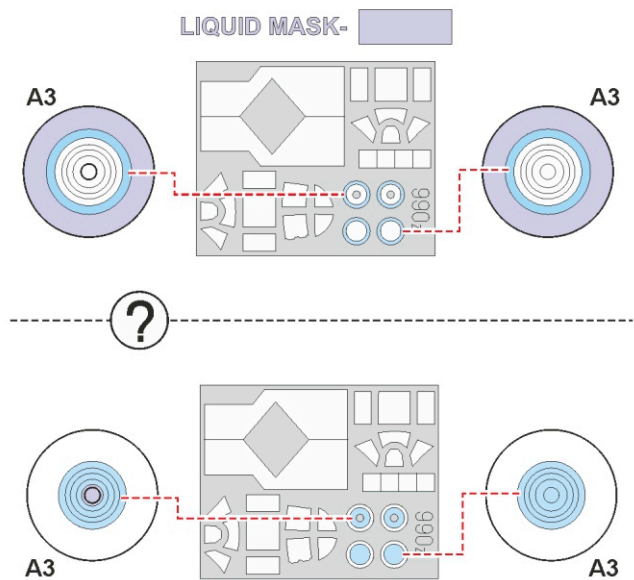
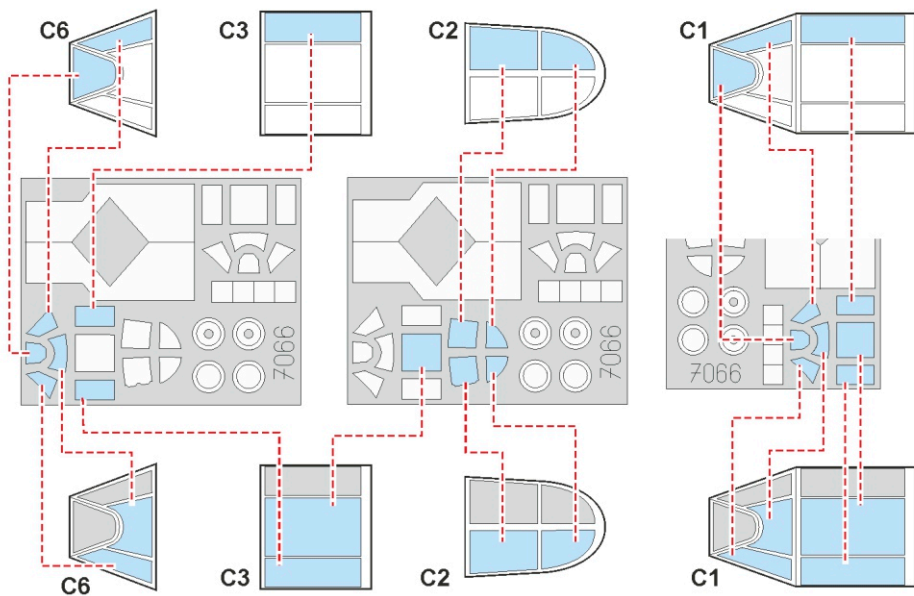

B flown by Maj. A. V. Alelyukhin, 9th GIAP, Berlin Operation, 1945

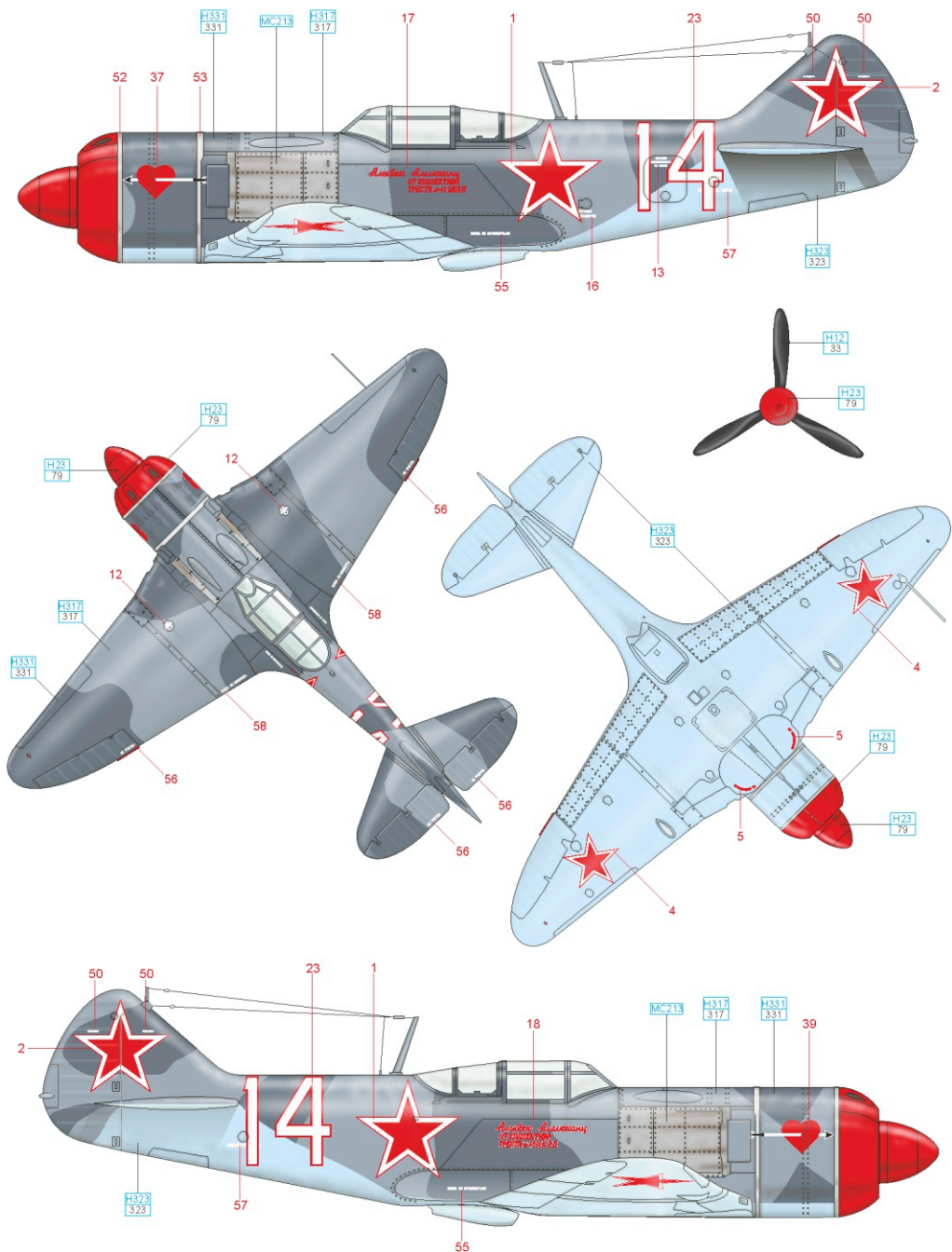

| | | | |
|-------|-------------|--------|-------------|
| BLACK | H117 33 | A-13 | H23 79 |
| AMT-7 | H323 323 | AMT-11 | H317 317 |
| | | AMT-12 | H331 331 |
| | | STEEL | MC213 |

C flown by Maj. Amet Khan Sultan, 9th GIAP, Germany, 1945

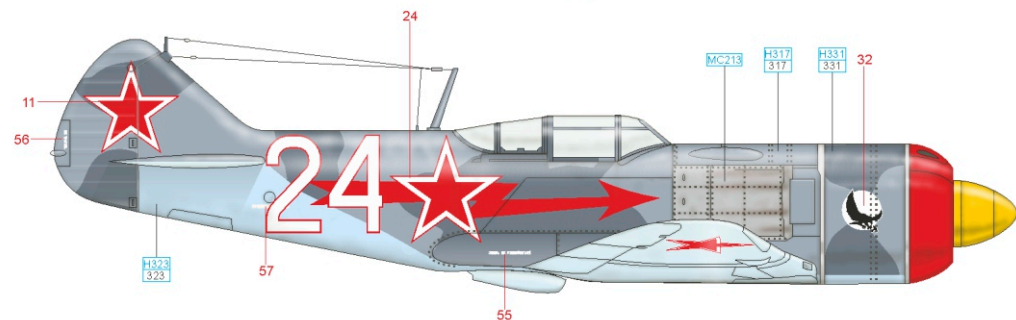
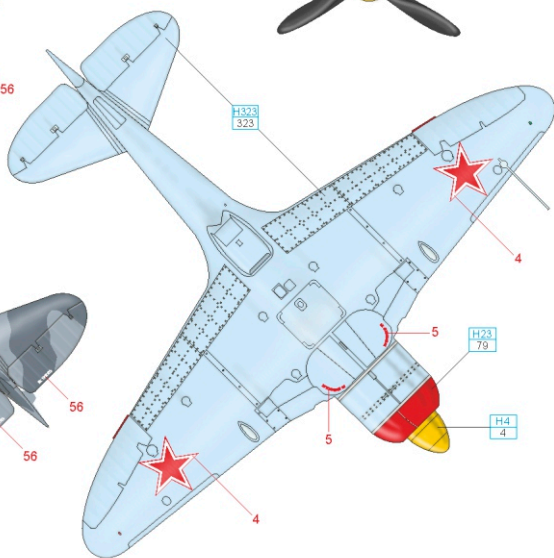
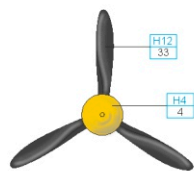
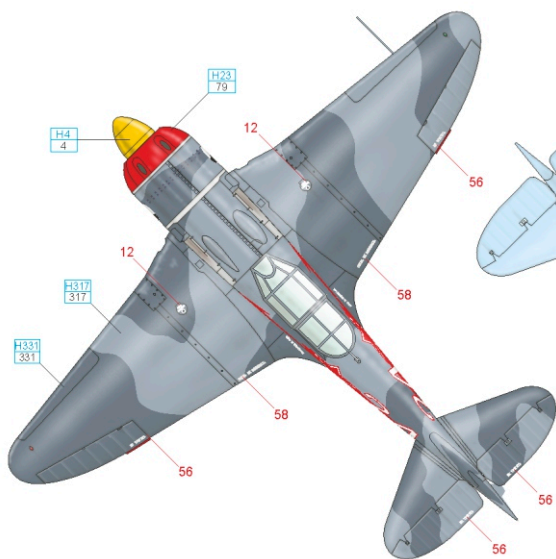
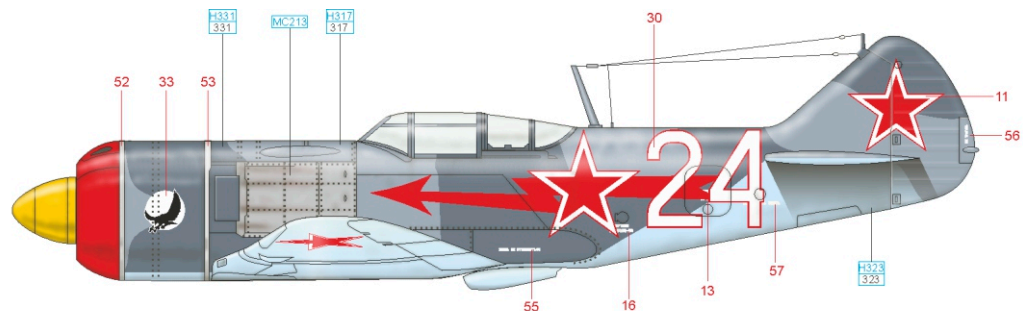

| | | | | | |
|-------|----------|--------|----------|--------|----------|
| BLACK | H17 33 | A-13 | H23 79 | A-6 | H4 4 |
| AMT-7 | H323 323 | AMT-11 | H317 317 | AMT-12 | H331 331 |
| | | | | STEEL | MC218 |

D flown by Lt.Col. S. F. Dolgushin, the Co of 156th IAP, Kluzov airfield, April, 1945

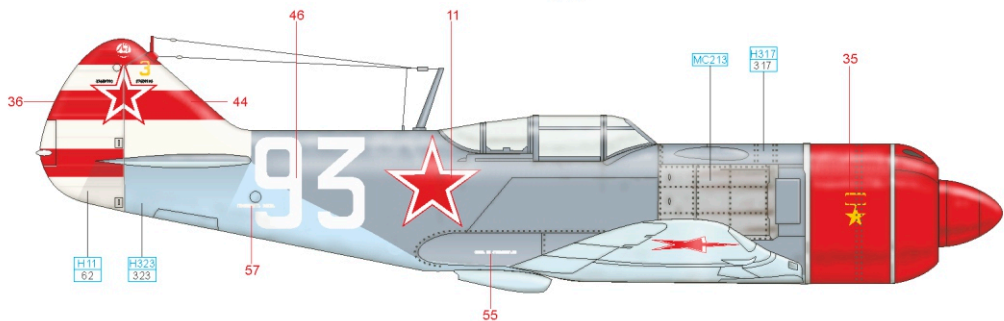
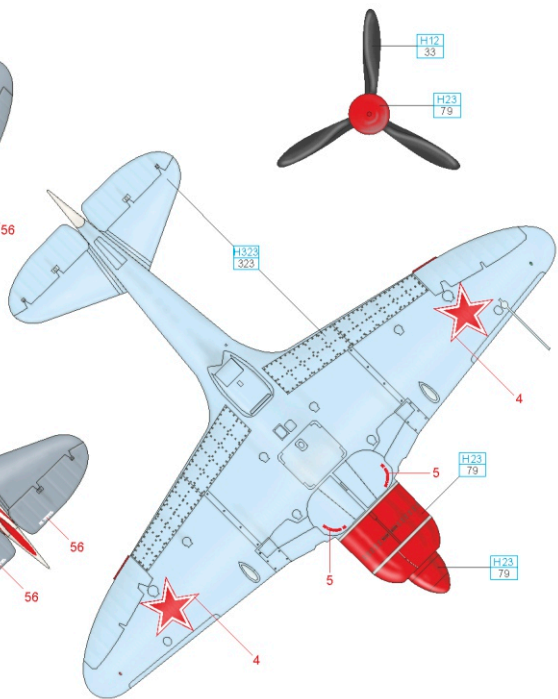
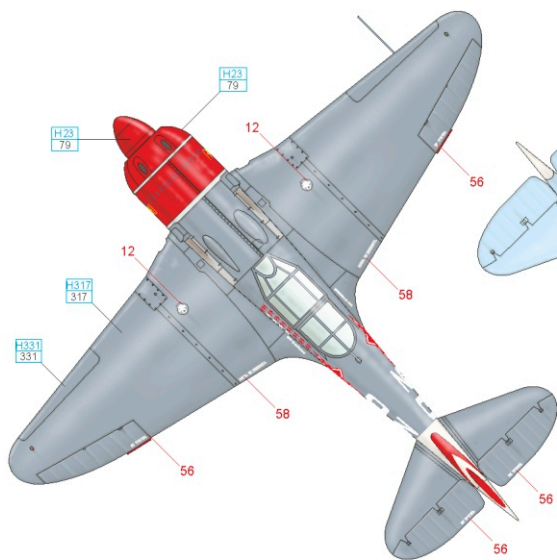
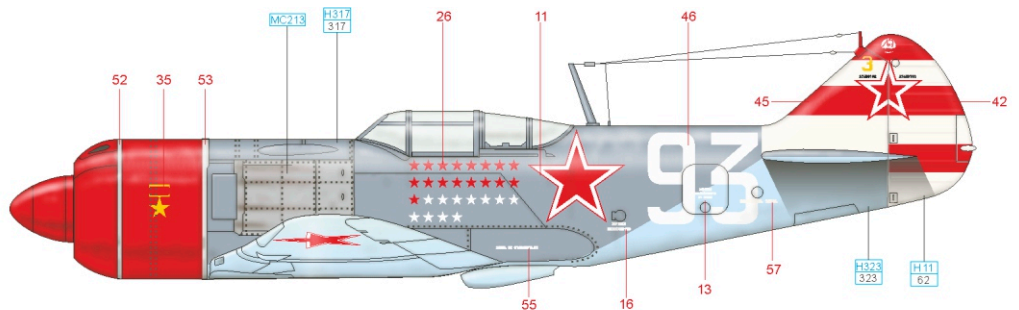

| | | | | | |
|-------|----------|--------|----------|-------|--------|
| BLACK | H12 33 | A-13 | H23 79 | WHITE | H11 62 |
| AMT-7 | H323 323 | AMT-11 | H317 317 | STEEL | MC213 |

G 2nd GIAP, 2nd Squadron „Mongolsky Arat”, spring, 1945

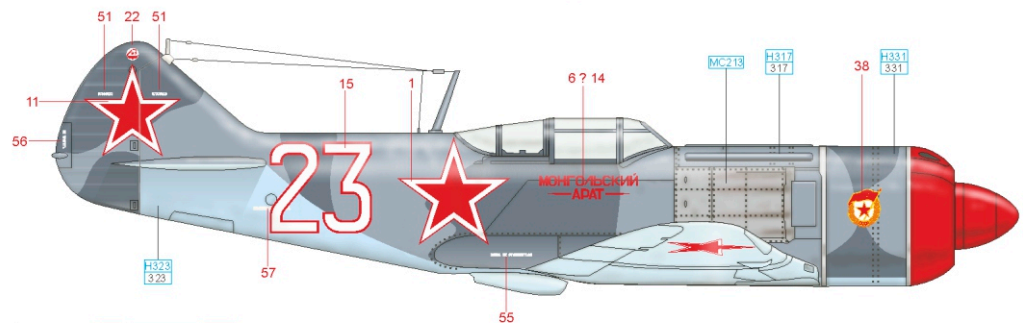
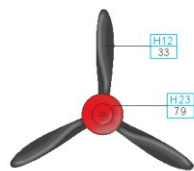
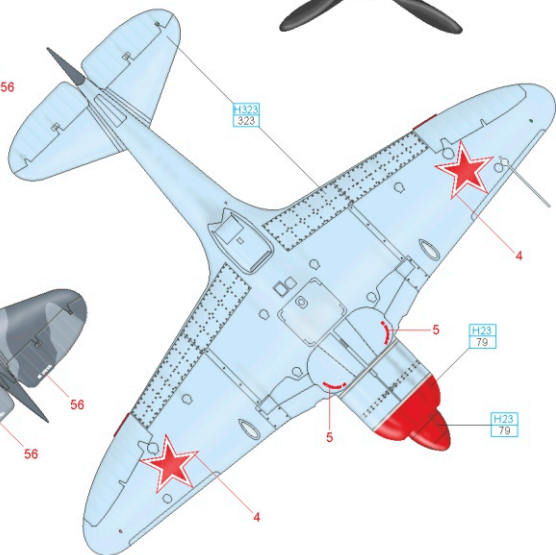
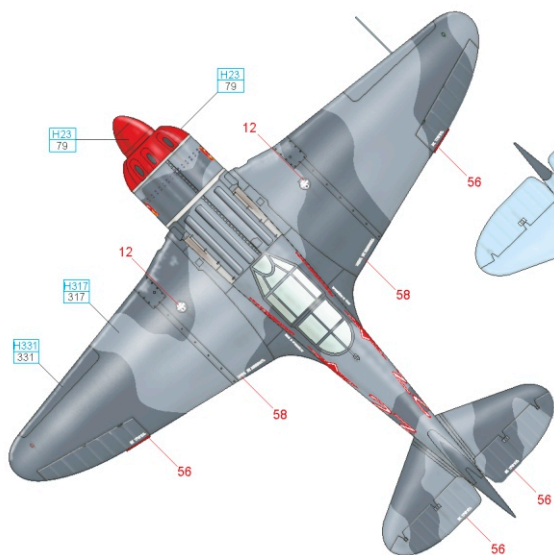
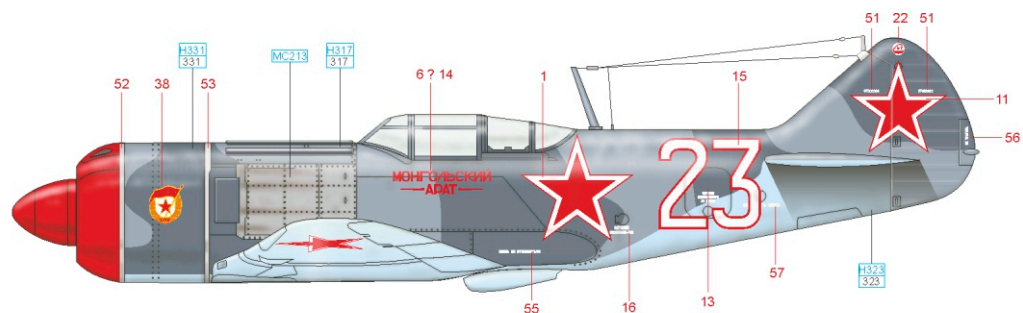

| | | | |
|-------|----------|--------|----------|
| BLACK | H12 33 | A-13 | H23 79 |
| AMT-7 | H323 323 | AMT-11 | H317 317 |
| | | AMT-12 | H331 331 |
| STEEL | MC-213 | | |

H the CO of 4th GIAP, Lt. Col Vasily F. Golubyev, spring 1945

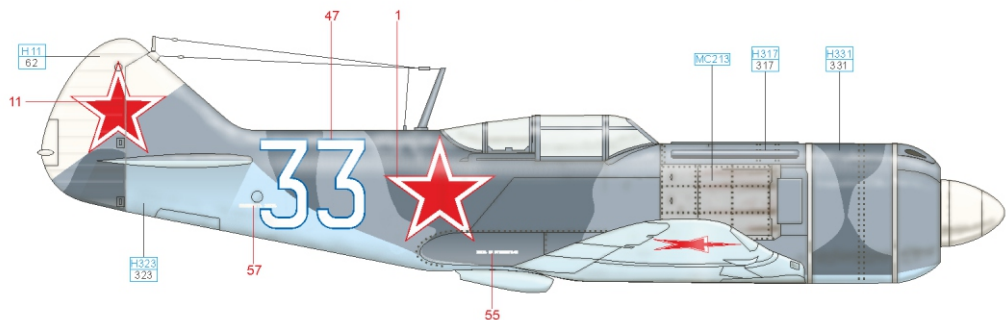
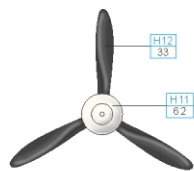
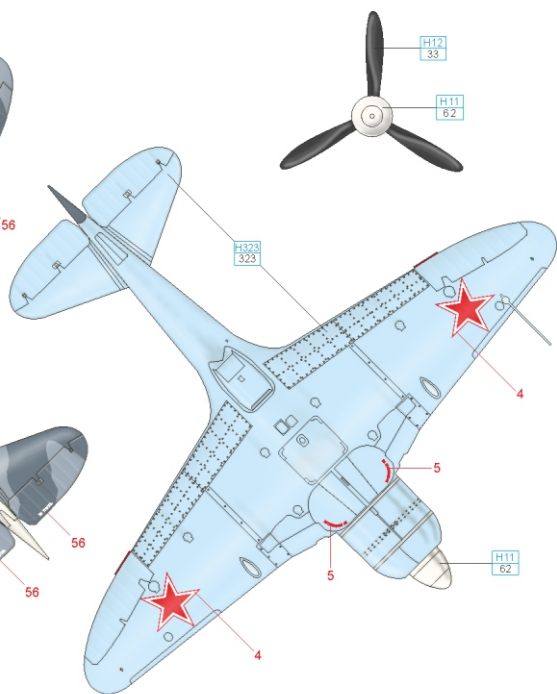
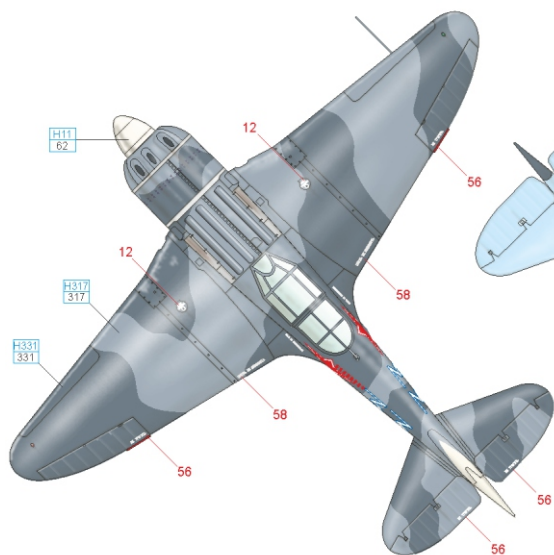
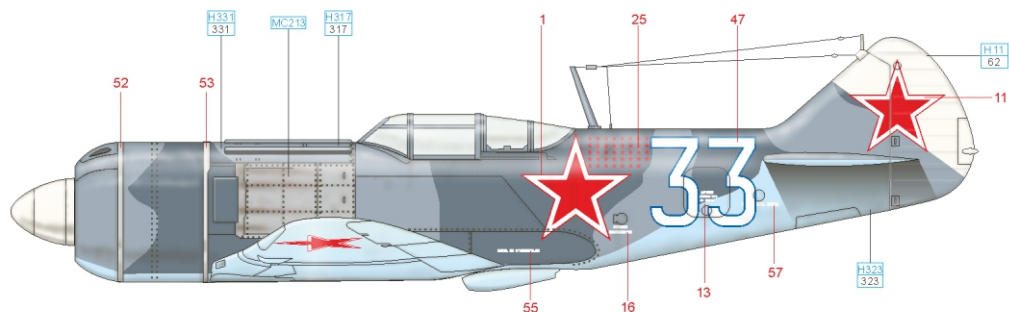

| | | | | | |
|-------|-------------|--------|-------------|--------|-------------|
| BLACK | H12 33 | WHITE | H11 62 | STEEL | MC213 |
| AMT-7 | H323 323 | AMT-11 | H317 317 | AMT-12 | H331 331 |