

BEDFORD QL Refueller

Cat. no. 72082

Scale 1/72



3D Design & Artwork: Jarosław Leoniec
Research: IBG crew

Przed montażem przeczytać instrukcję. Przestrzegać kolejności montażu podanej w instrukcji! Klej i farby nie wchodzi w skład zestawu.
Please read instruction before assembly. Obey sequence of assembly like in instruction. Glue and paints not included.



- 1 Element złożony we wcześniejszym etapie
Element assembled in previous step
- 1 Element po złożeniu w aktualnym etapie
Element after assembly in actual step
- ? Wersja do wyboru
Version to choose
- 1 Kalkomania
Decal
- A Kolor farby
Paint colour
- Część nie do użycia
Part not for use
- 45° Zegnij część fototrawioną
Bend photoetched part
- Po gięciu
After bending

		Vallejo Model Air	Hataka	Mr Hobby H	Mr Hobby C	Lifecolor	AK Interactive
Black	A	71.057	HTK-A159	H002	C002	LC02	AK719
Light Gray	B	71.050	HTK-A050	H324	C097	UA34	AK2231
RAF Blue Grey	C	71.115	HTK-A145	H042	C328	UA044	AK2162
Golden Yellow	D	71.078	HTK-A275	H004	C004	UA140	AK11041
White	E	71.001	HTK-A049	H011	C062	LC01	RC004
Tire Black	F	71.315	HTK-A041	H077	C137	UA733	AK11027

Części fototrawione / Photoetched parts

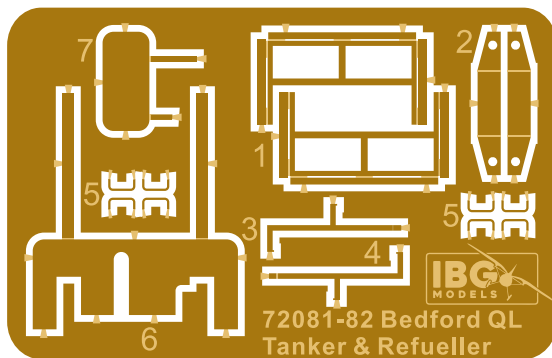

Klisza / Clear film

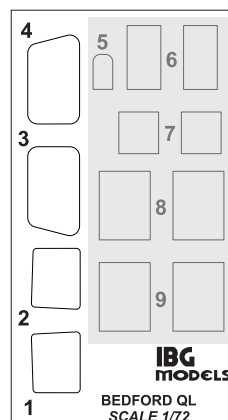

Kalkomania / Decal

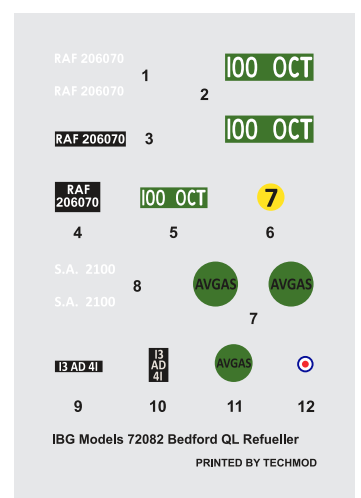

International Business Group
ul. Benedykta Hertzka 2
04-603 Warszawa
Poland

tel +48 22 8159150
fax +48 22 8159151
ibgsc@ibg.com.pl
www.ibg.com.pl
www.ibgmodels.com

Ramka bez oznaczenia literowego / *Frame with no letter*

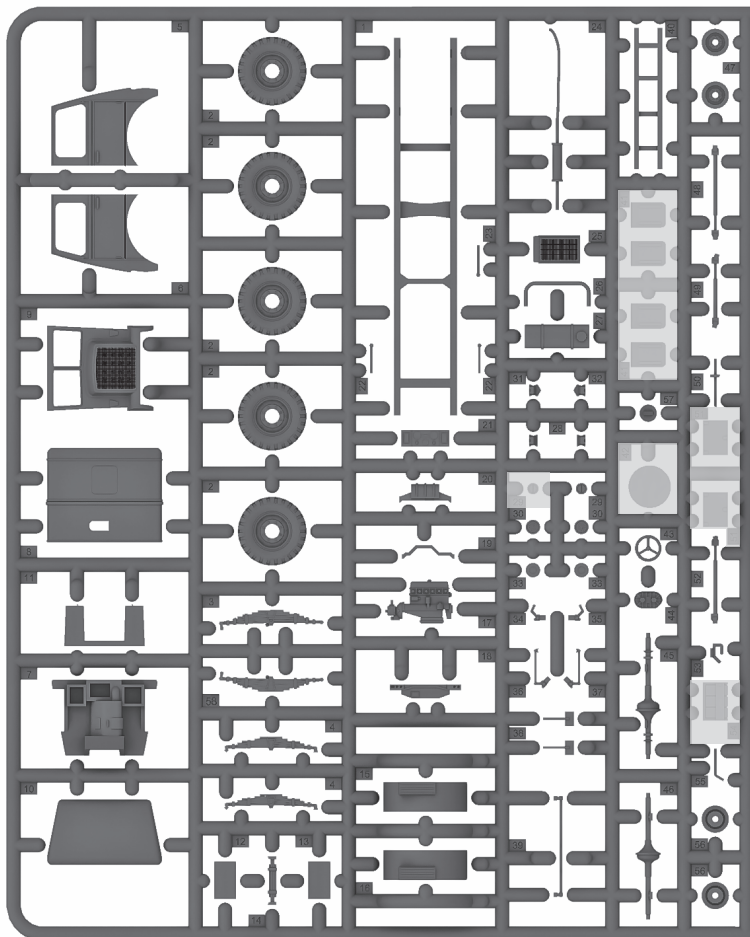

Ramka E - 2 szt / *Frame E - 2 pcs*

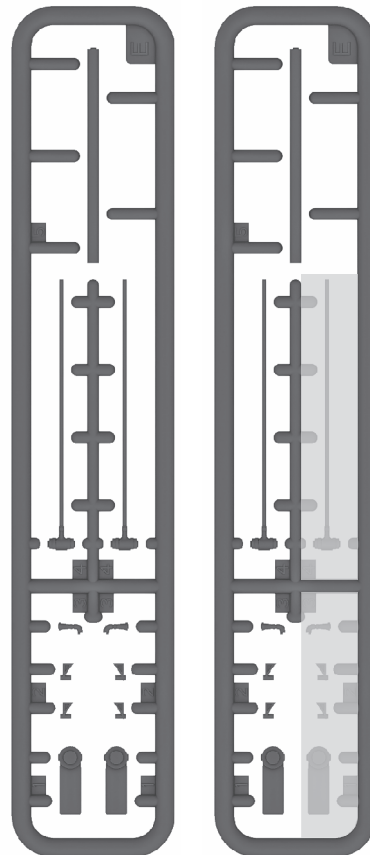

Ramka A / *Frame A*

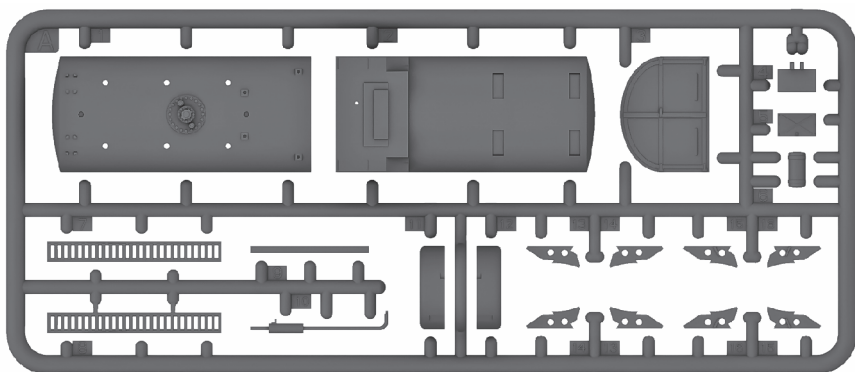

Ramka C - 2 szt / *Frame C - 2 pcs*

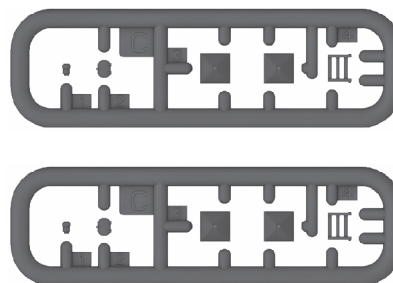

Ramka B / *Frame B*

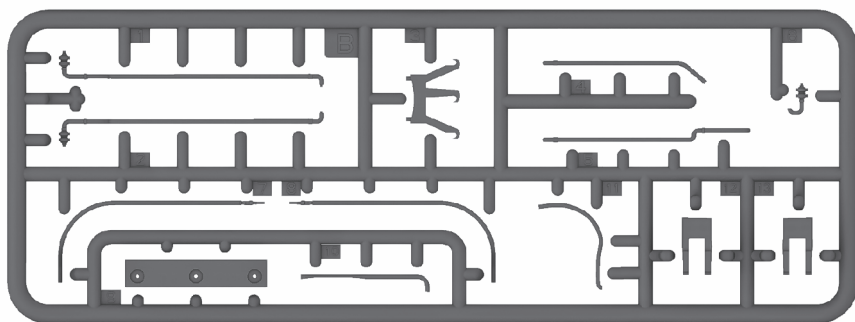

International Business Group
ul. Benedykta Hertza 2
04-603 Warszawa
Poland

tel +48 22 8159150
fax +48 22 8159151
ibgsc@ibg.com.pl
www.ibg.com.pl
www.ibgmodels.com

**ETAP 1
STEP 1**

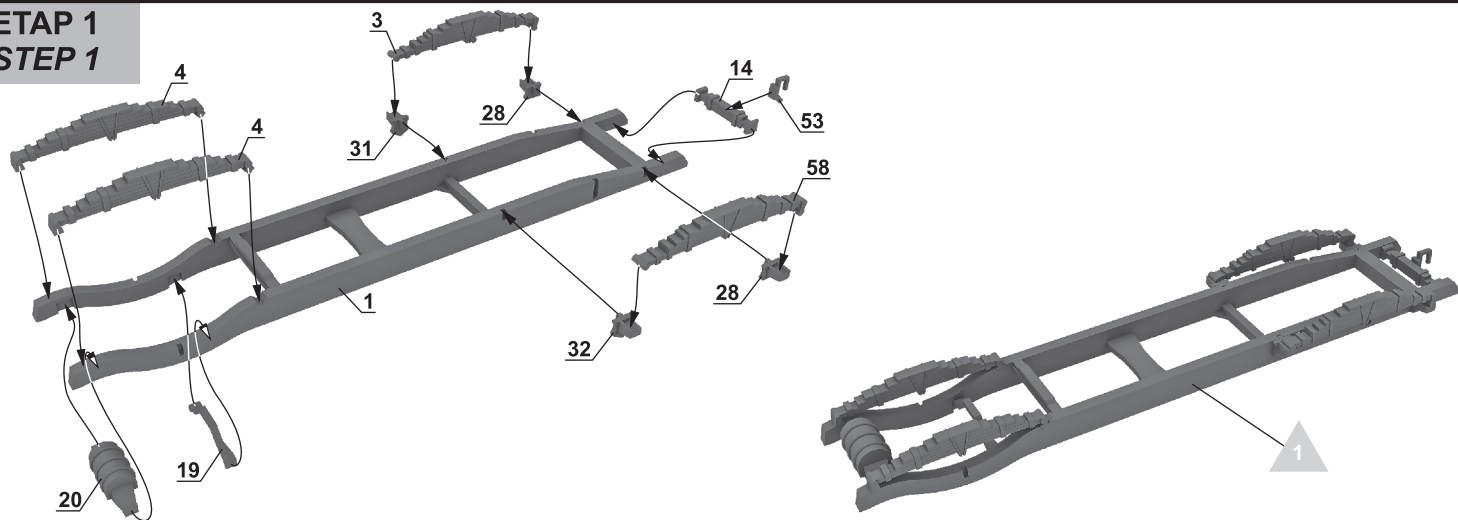

**ETAP 2
STEP 2**

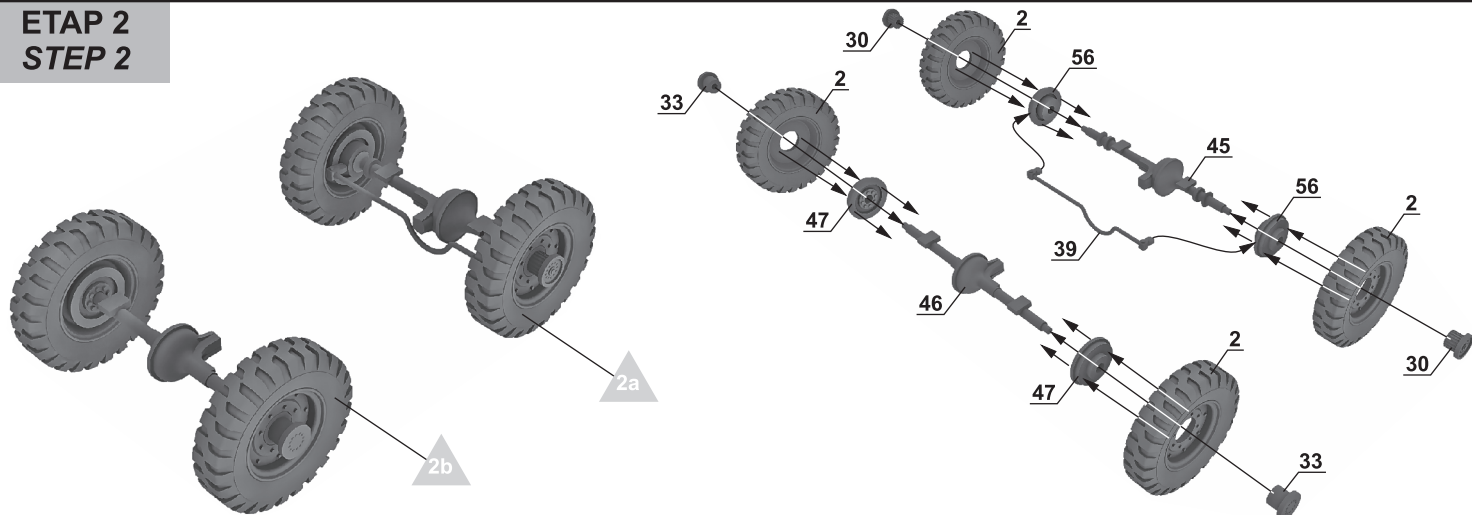

**ETAP 3
STEP 3**

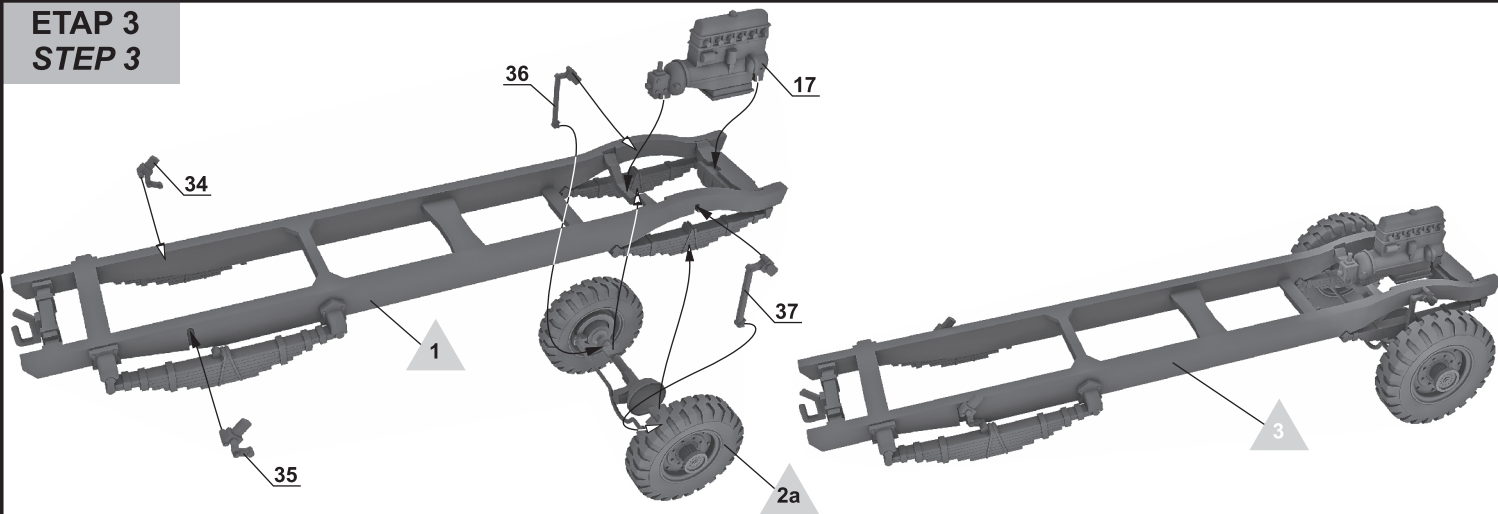

**ETAP 4
STEP 4**

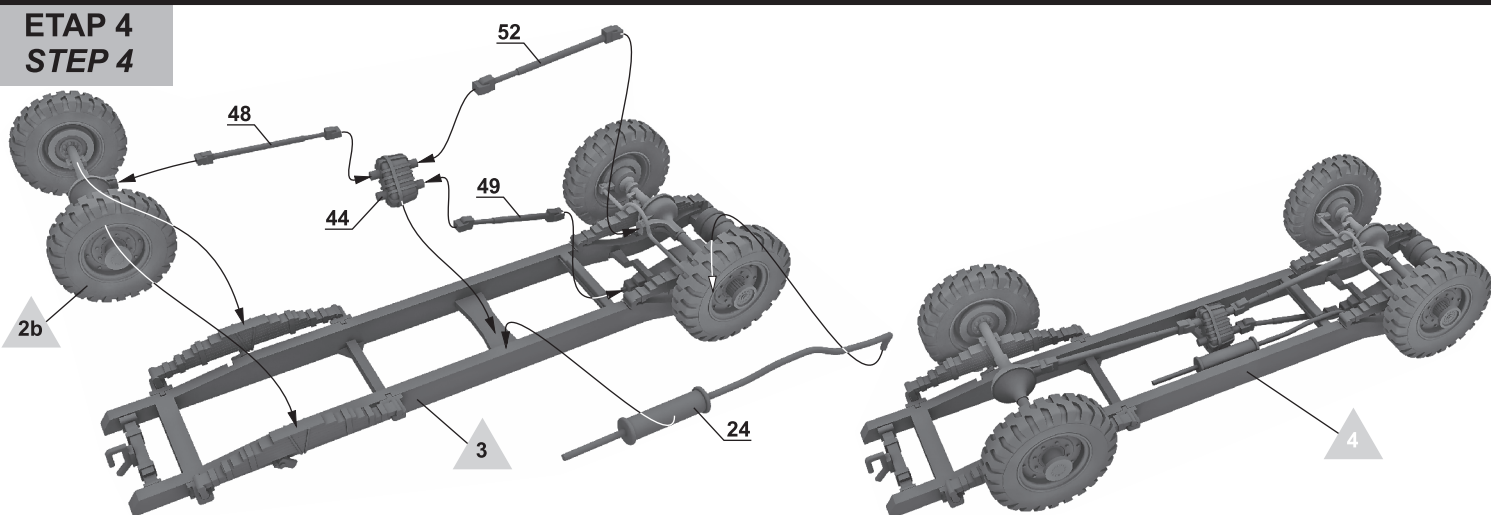

**ETAP 5
STEP 5**

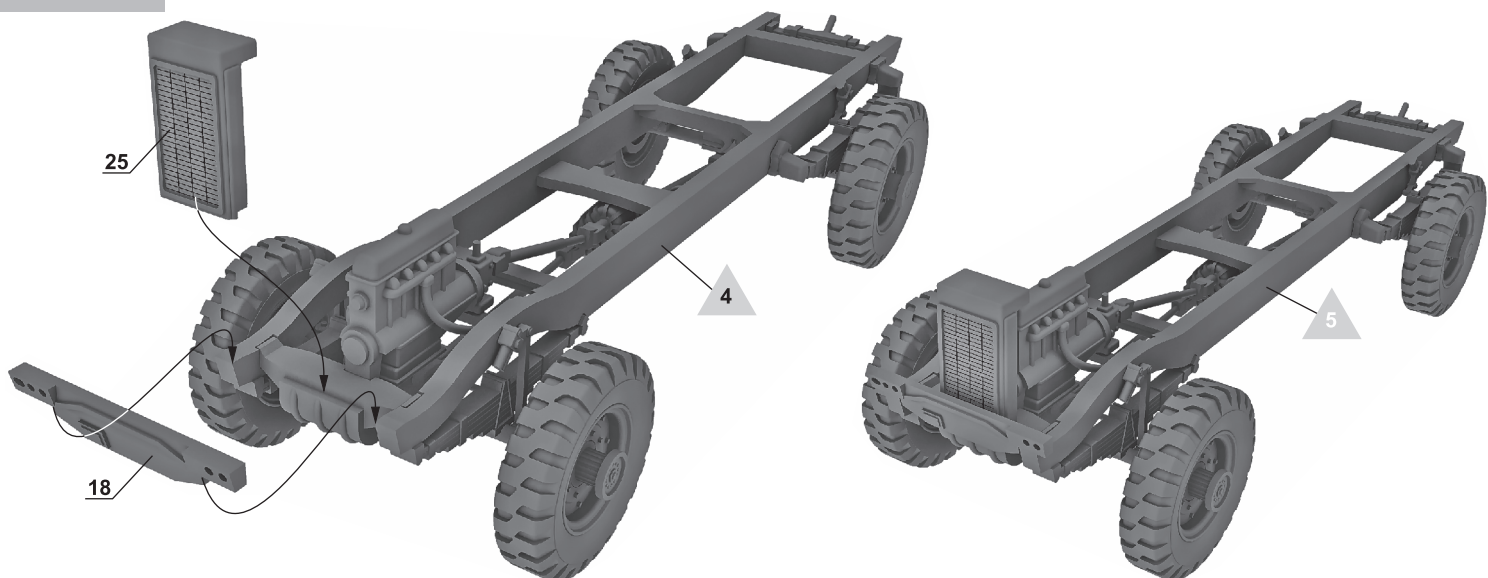

**ETAP 6
STEP 6**

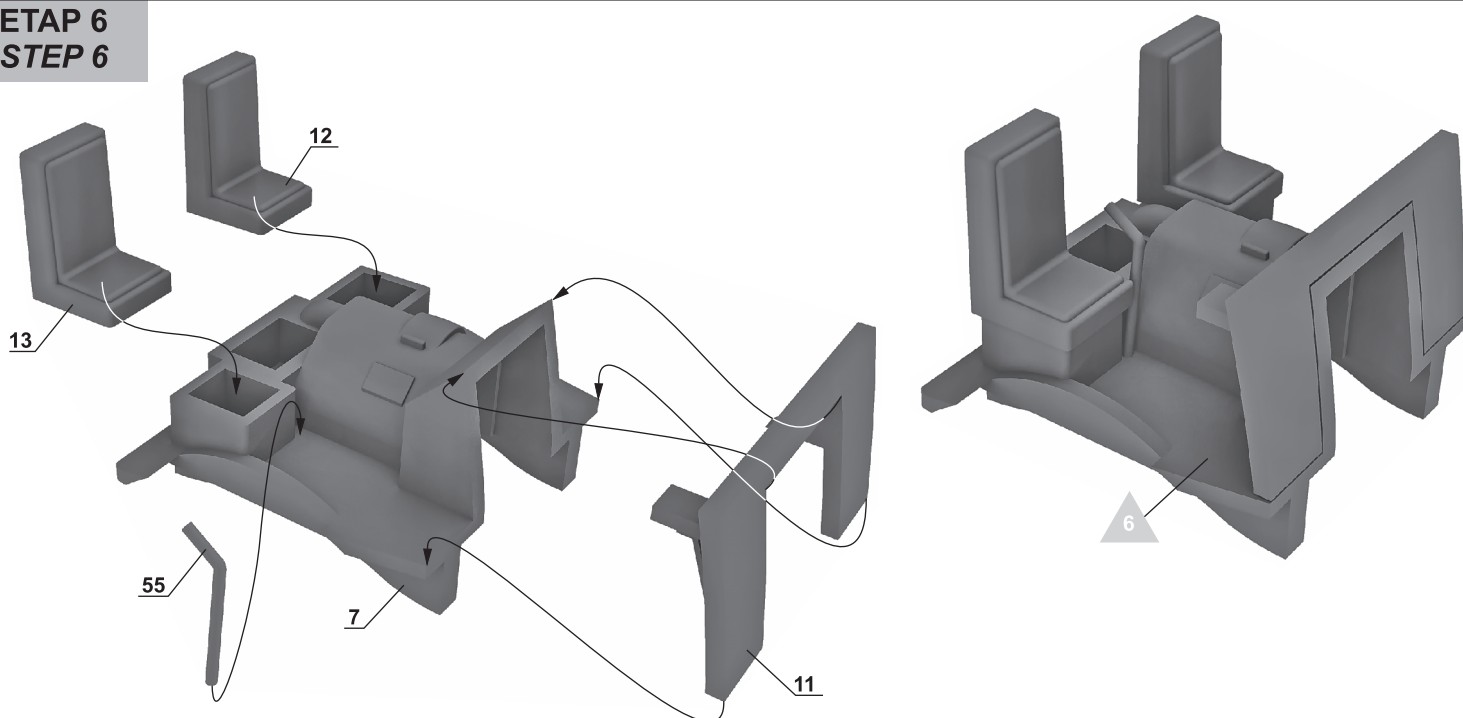

**ETAP 7
STEP 7**

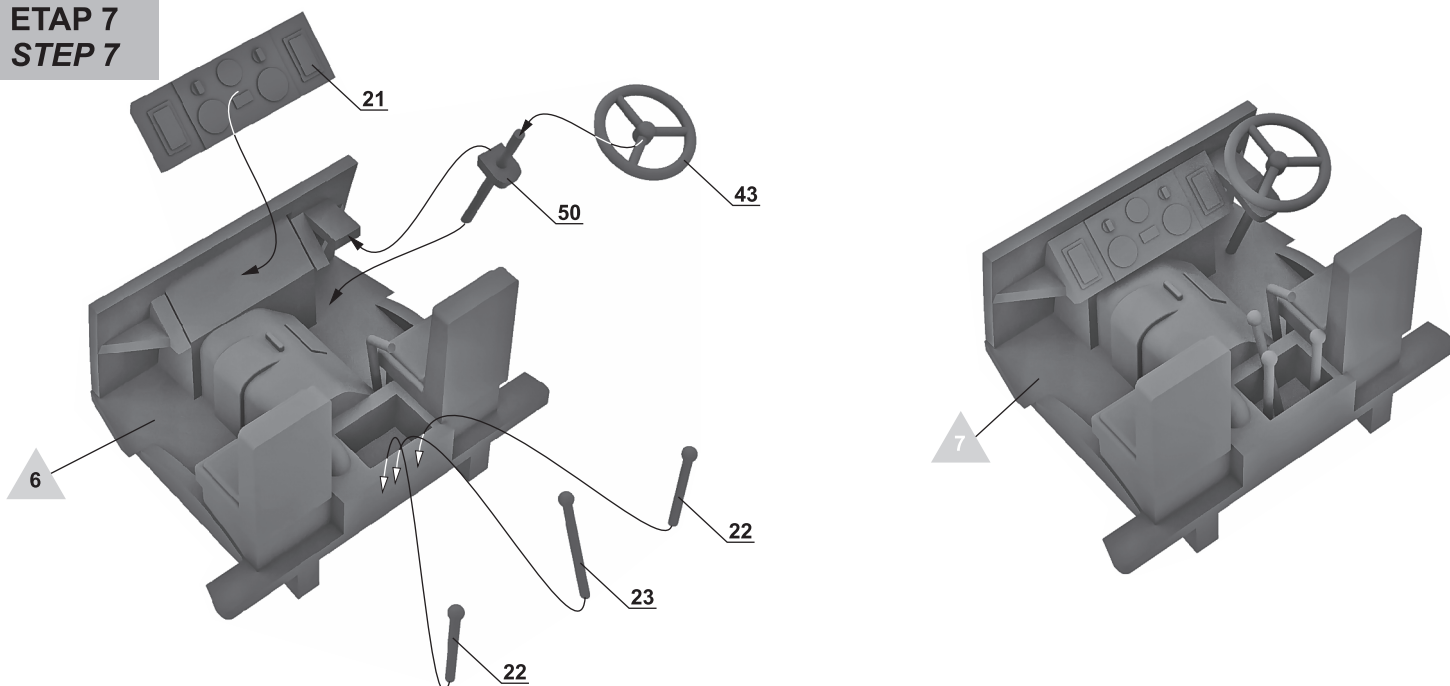

**ETAP 8
STEP 8**

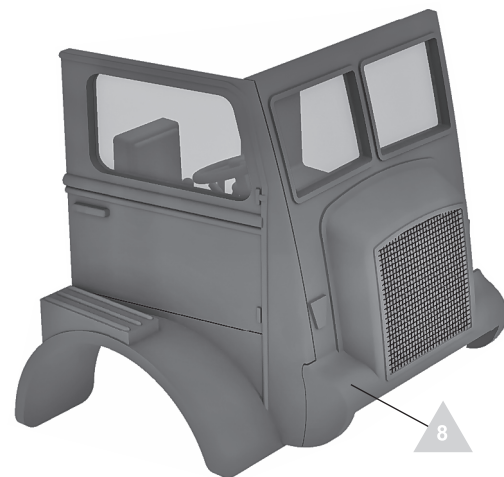
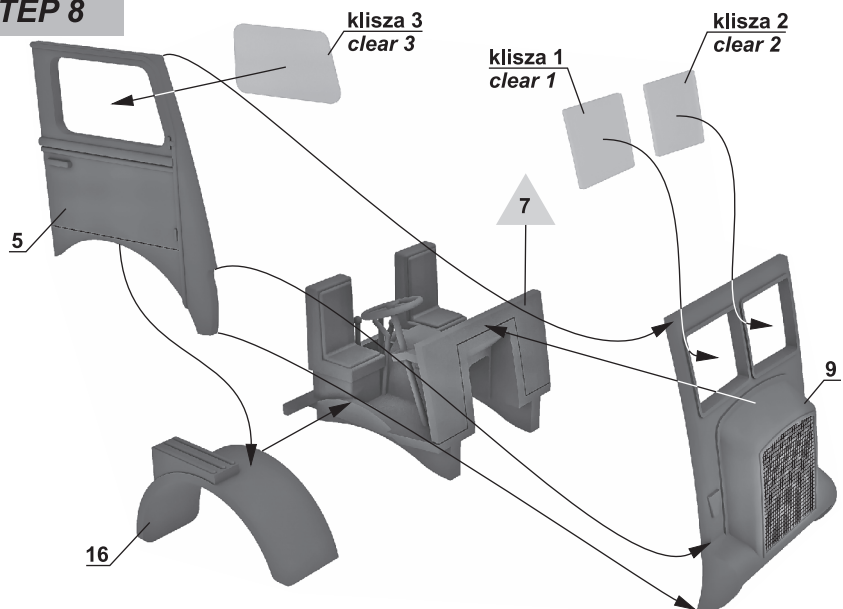

**ETAP 9
STEP 9**

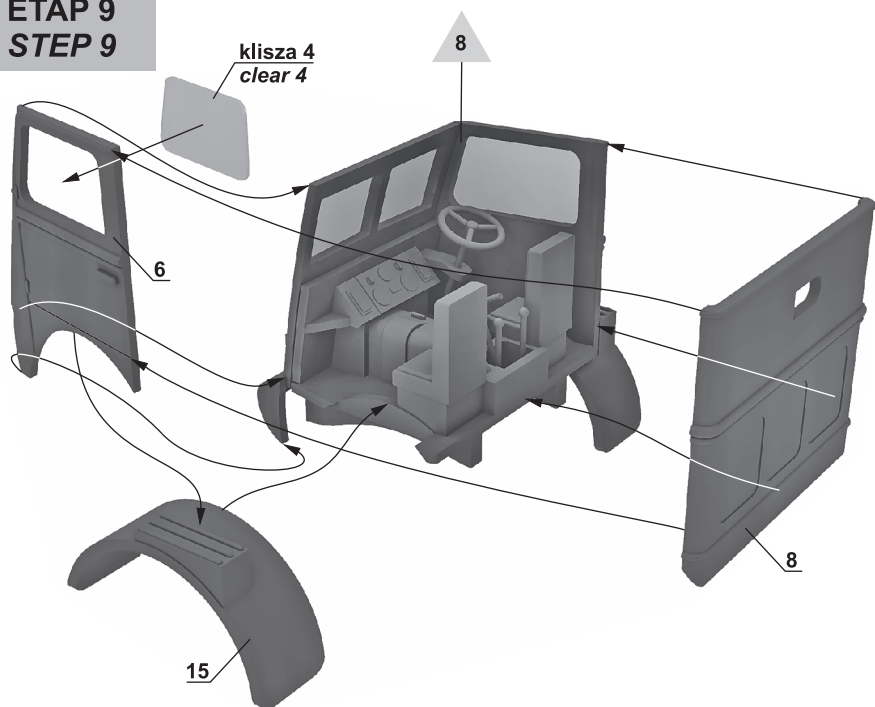

**ETAP 10
STEP 10**

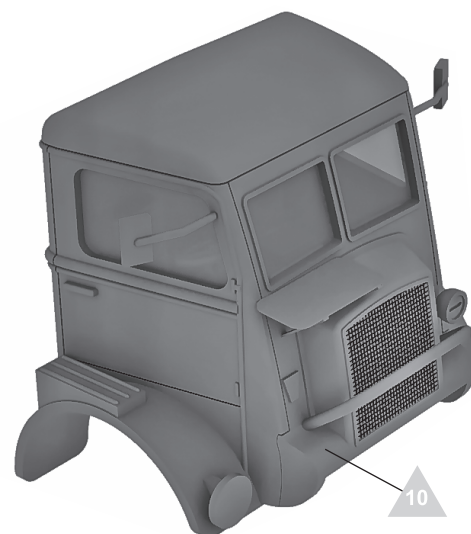
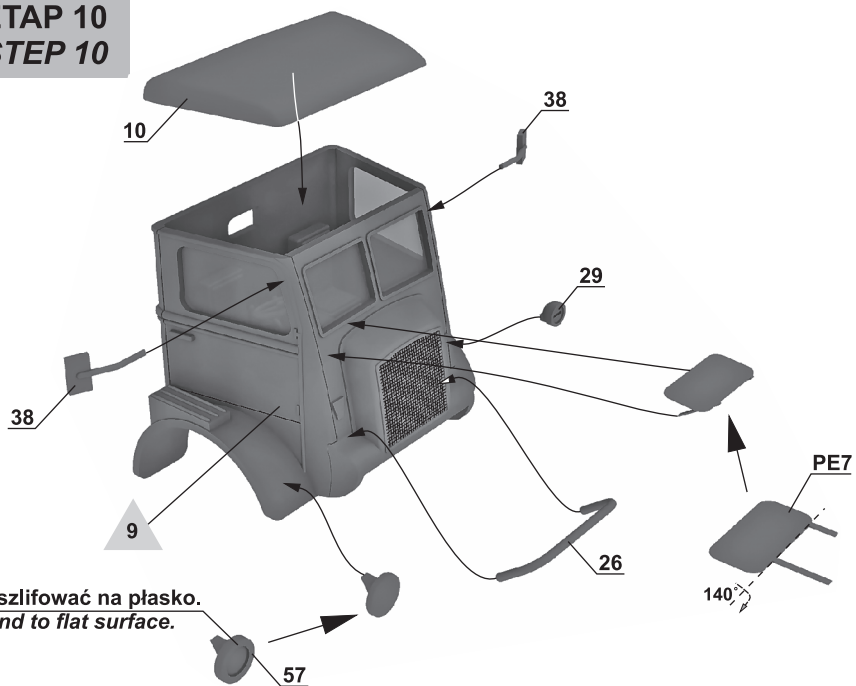

ETAP 11
STEP 11

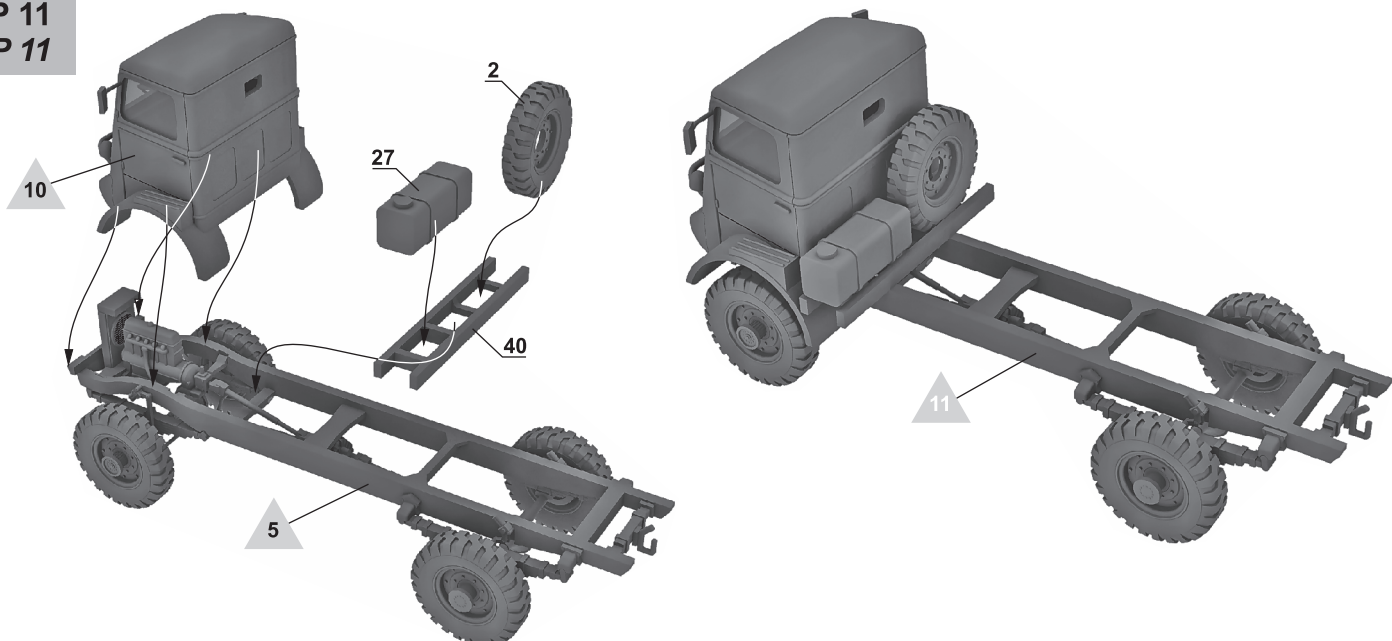

ETAP 12
STEP 12

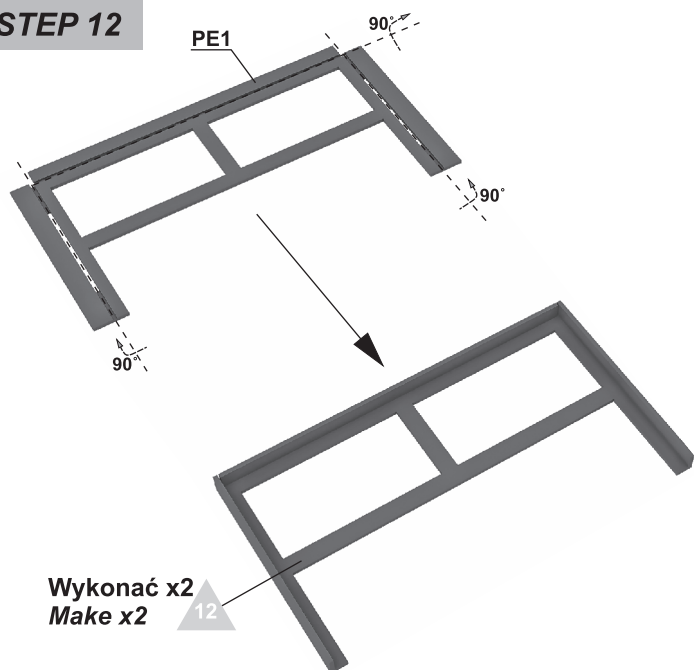

ETAP 13
STEP 13

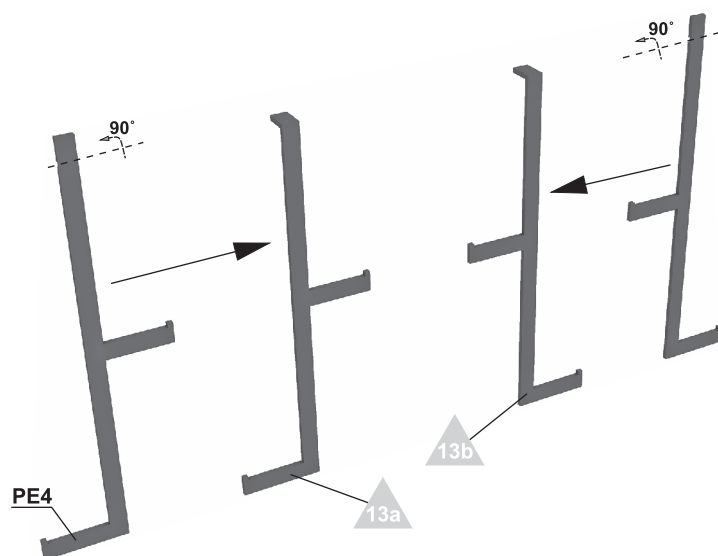

ETAP 14
STEP 14

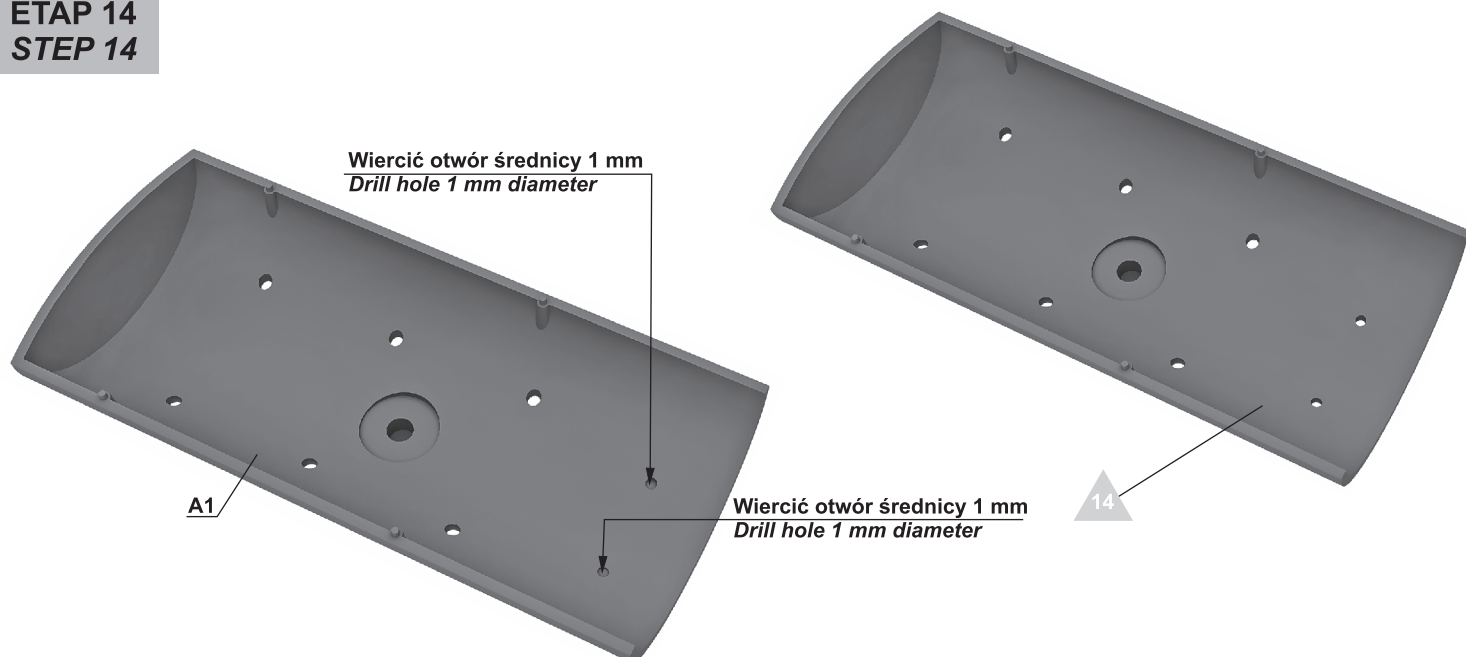

ETAP 15
STEP 15

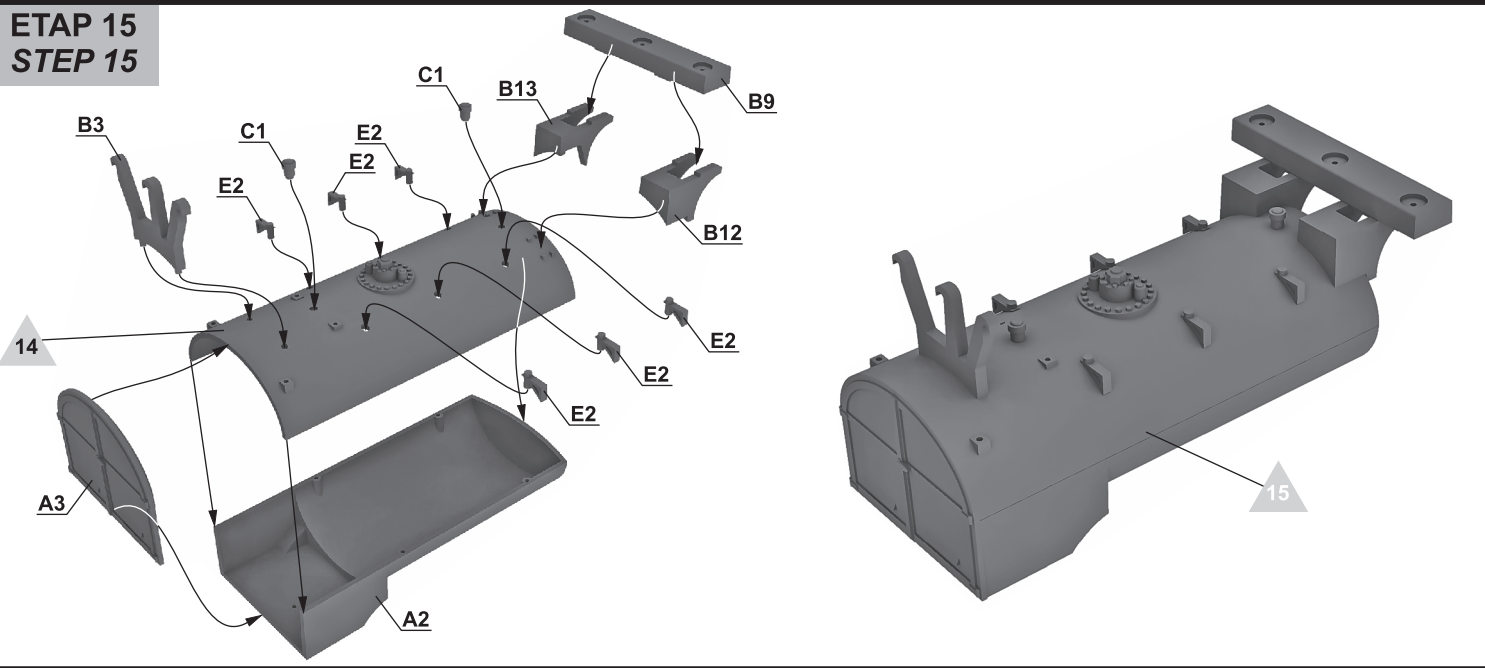

ETAP 16
STEP 16

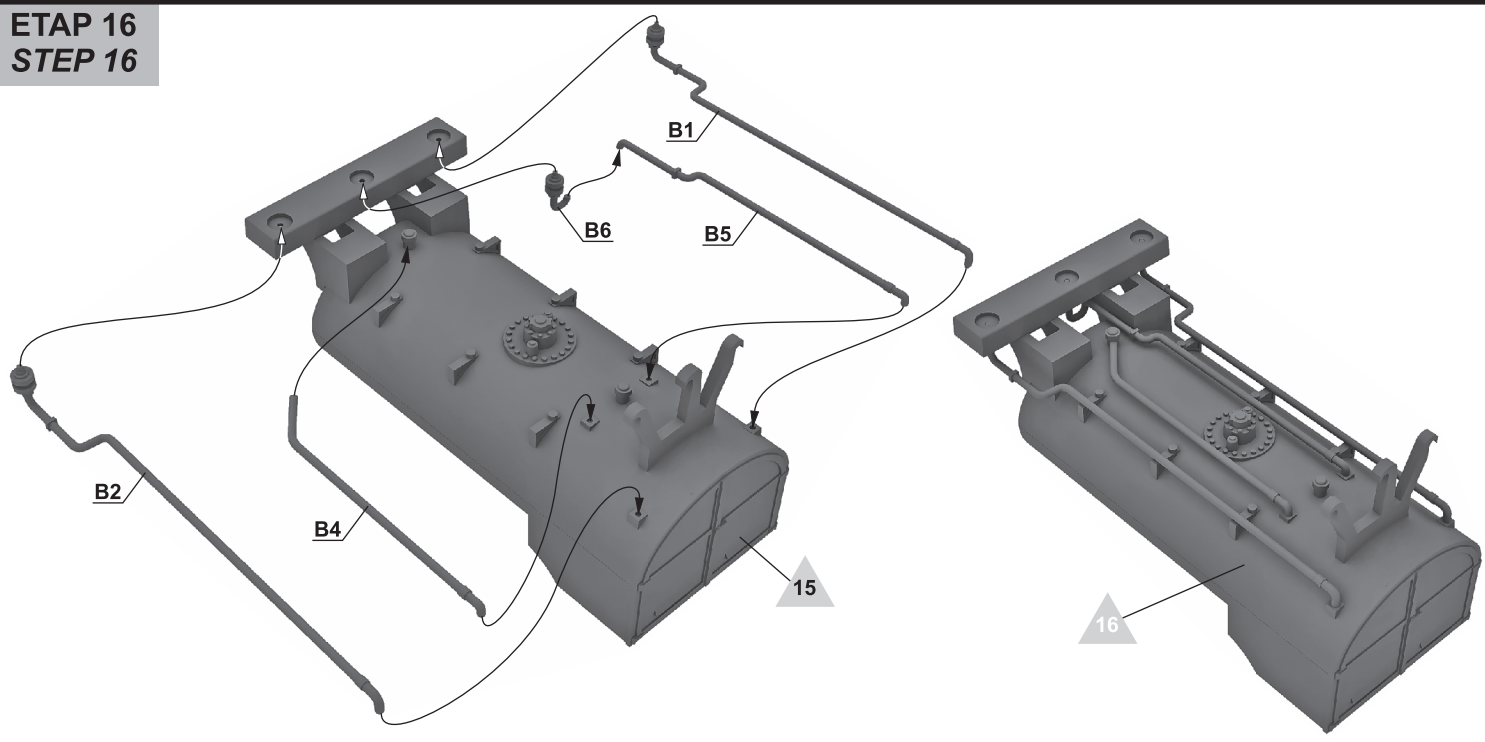

ETAP 17
STEP 17

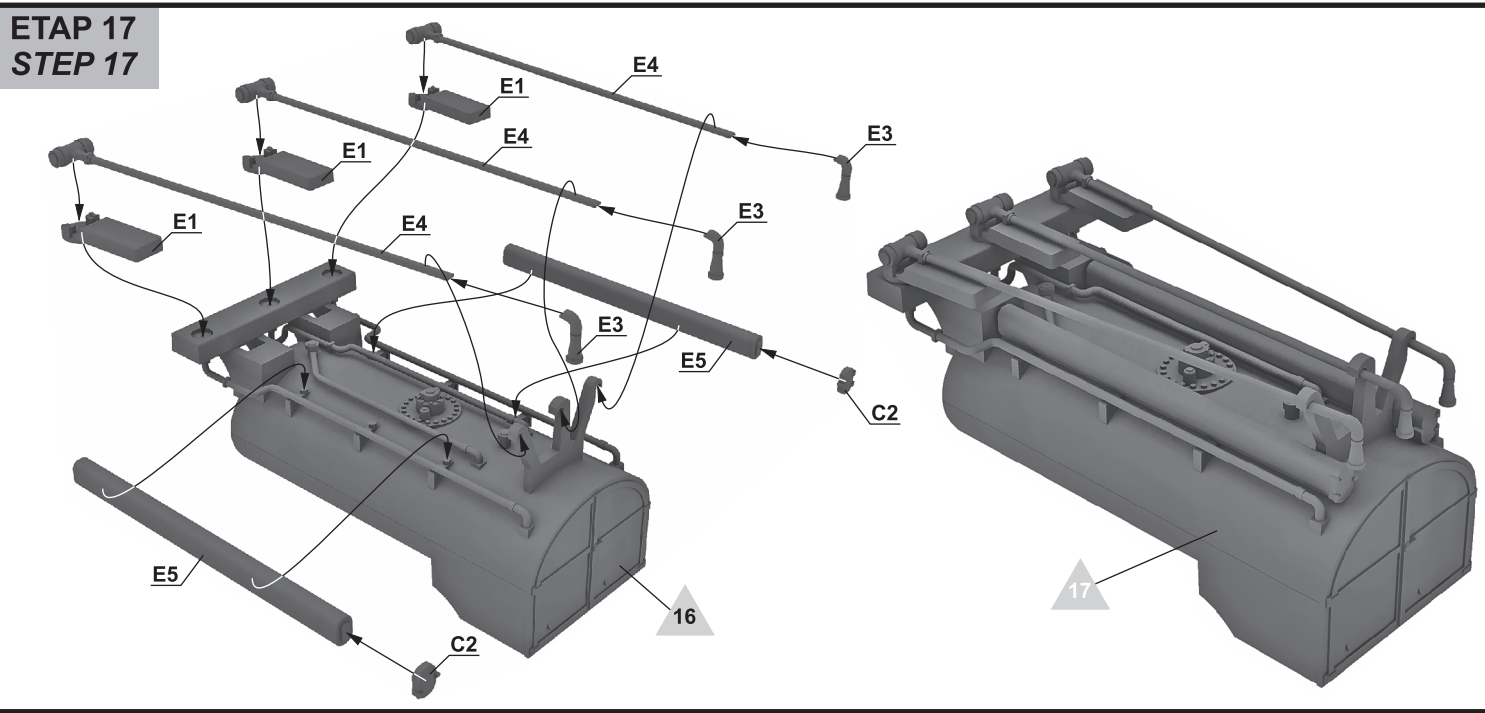

ETAP 18
STEP 18

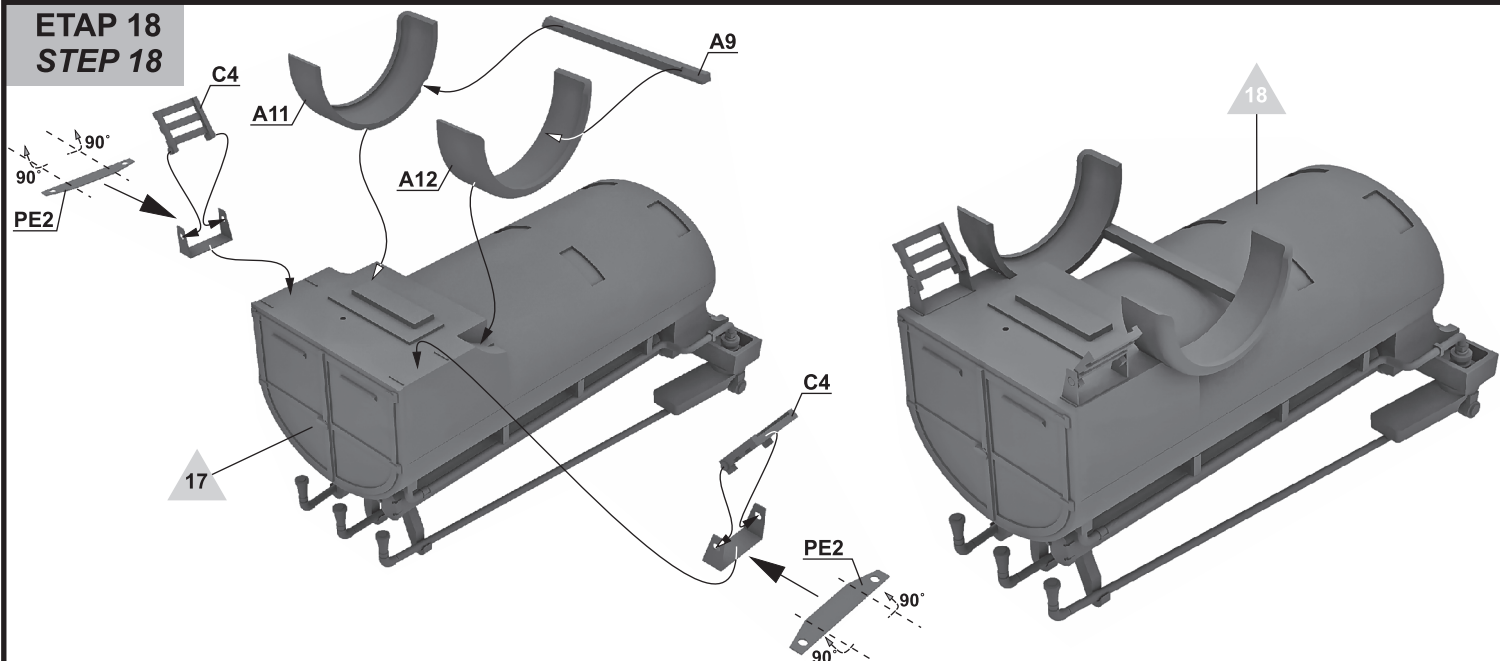

ETAP 19
STEP 19

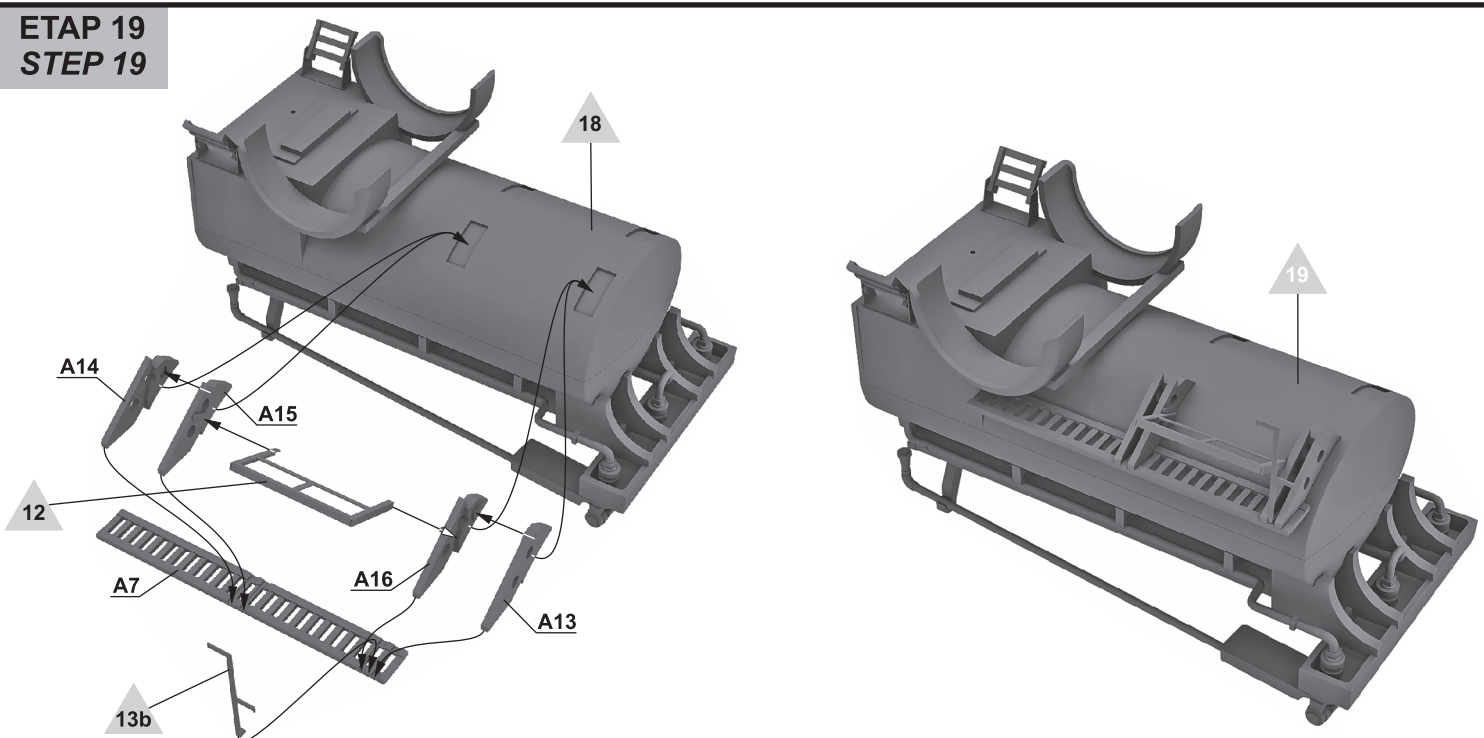

ETAP 20
STEP 20

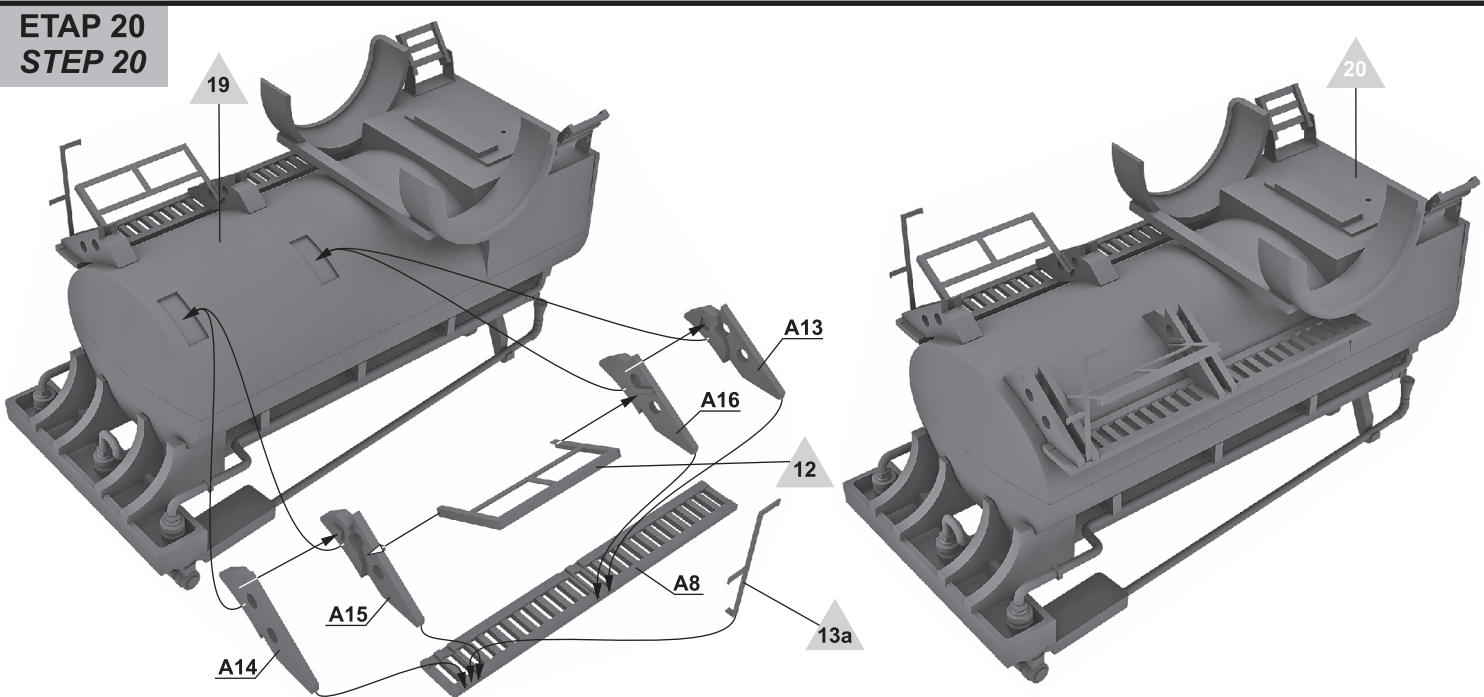

ETAP 21
STEP 21

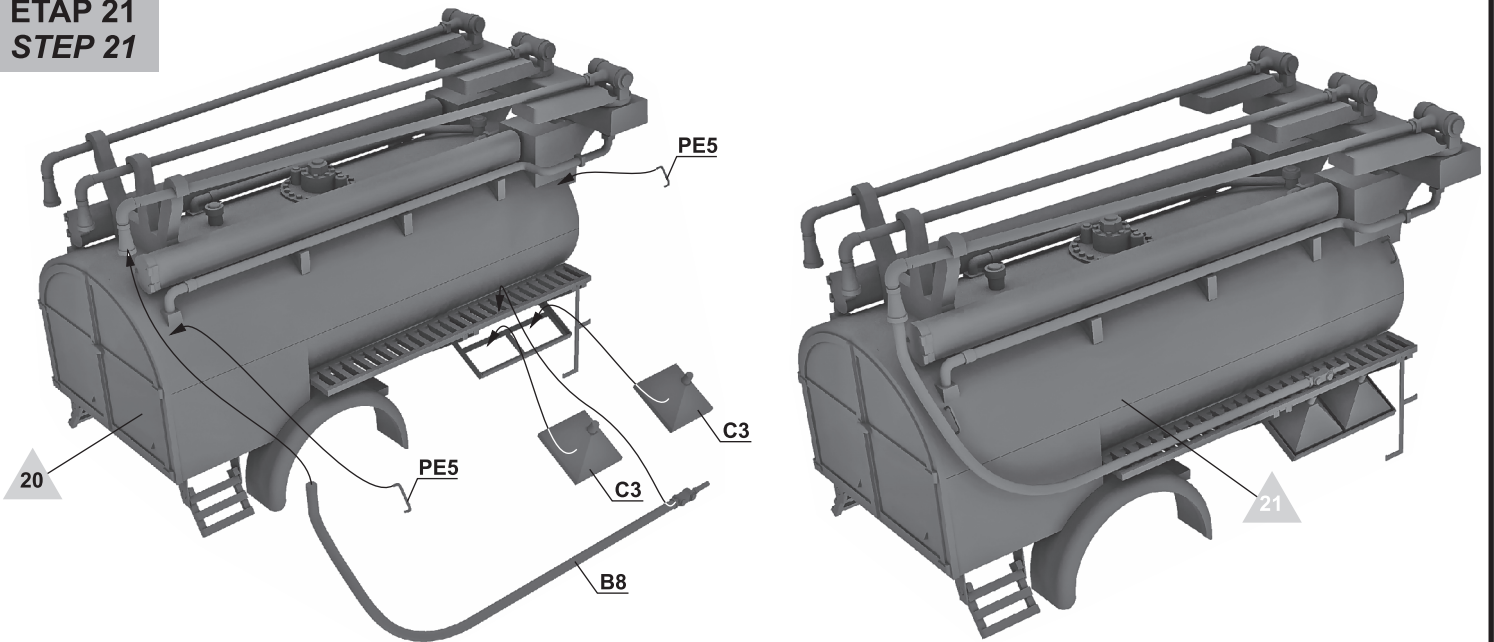

ETAP 22
STEP 22

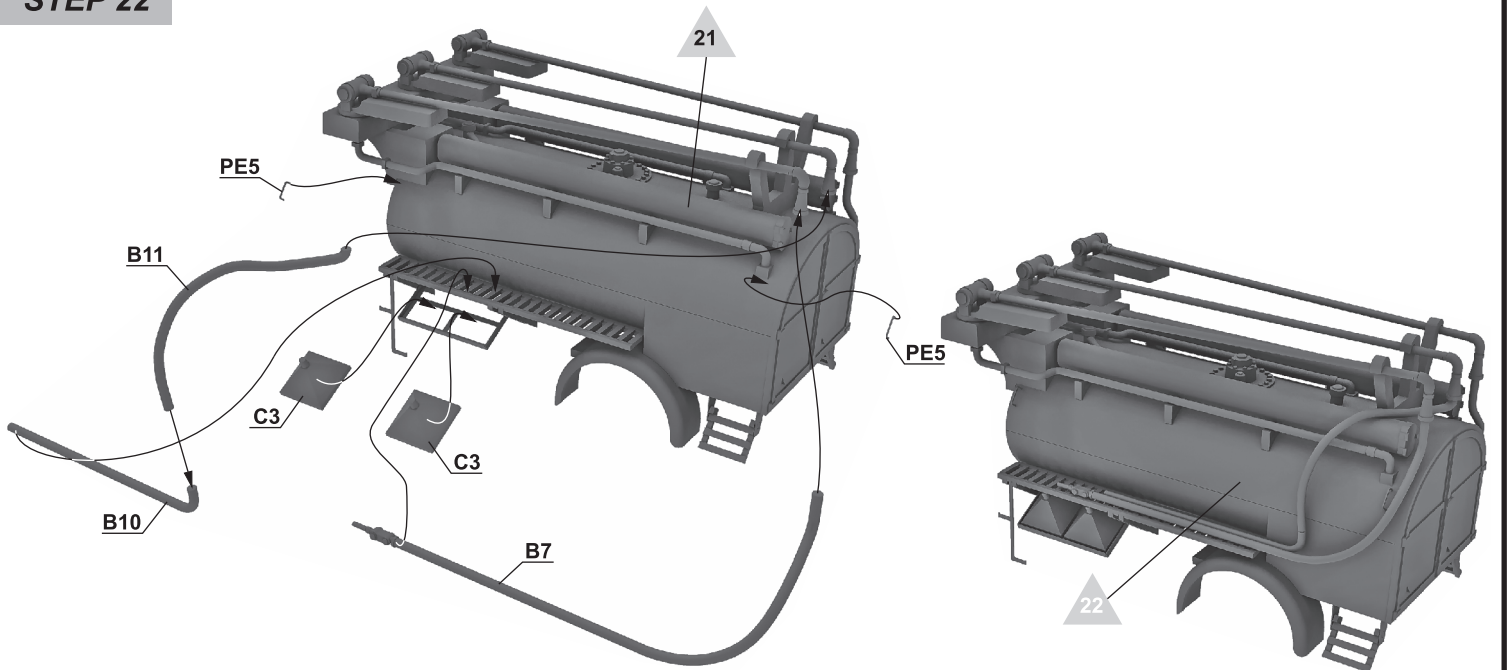

ETAP 23
STEP 23

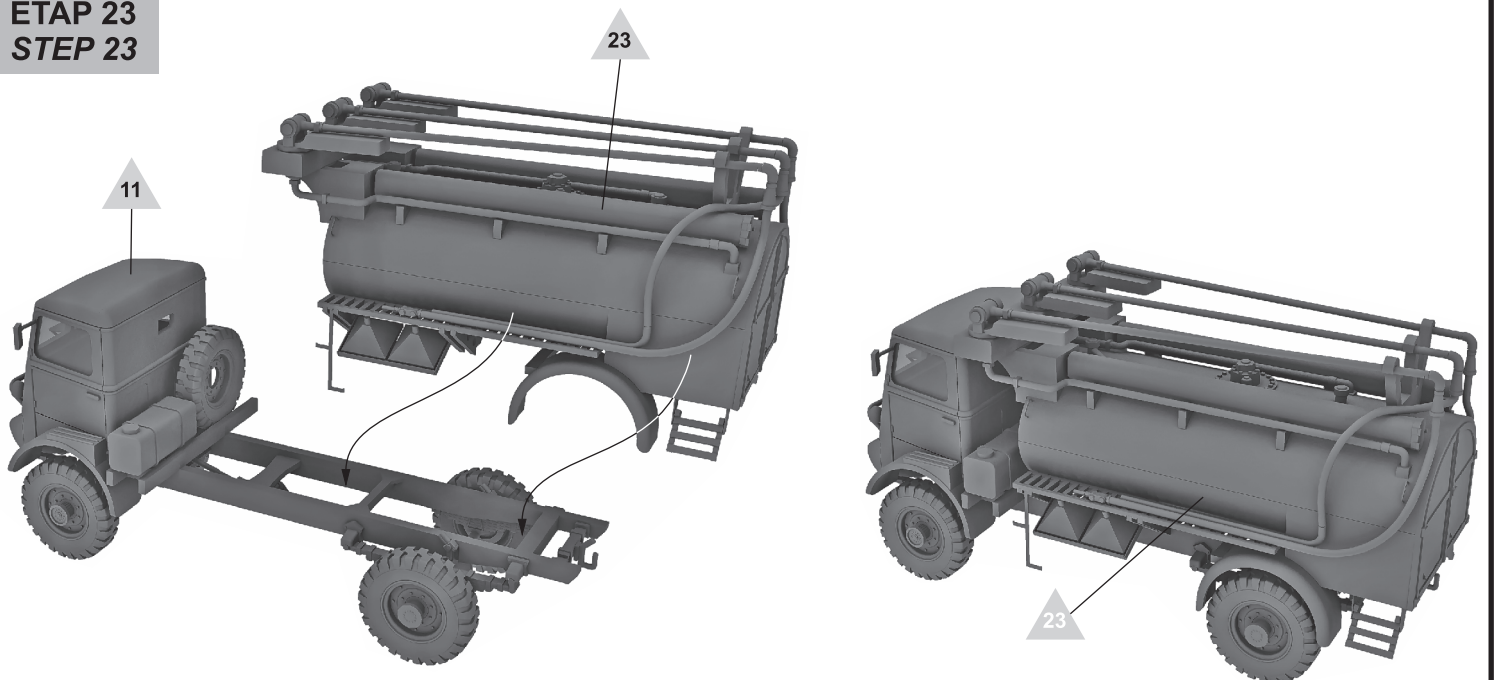

ETAP 24
STEP 24

Dogać do kształtu tylnej powierzchni błotników.
Bend to the shape of rear surface of fenders.

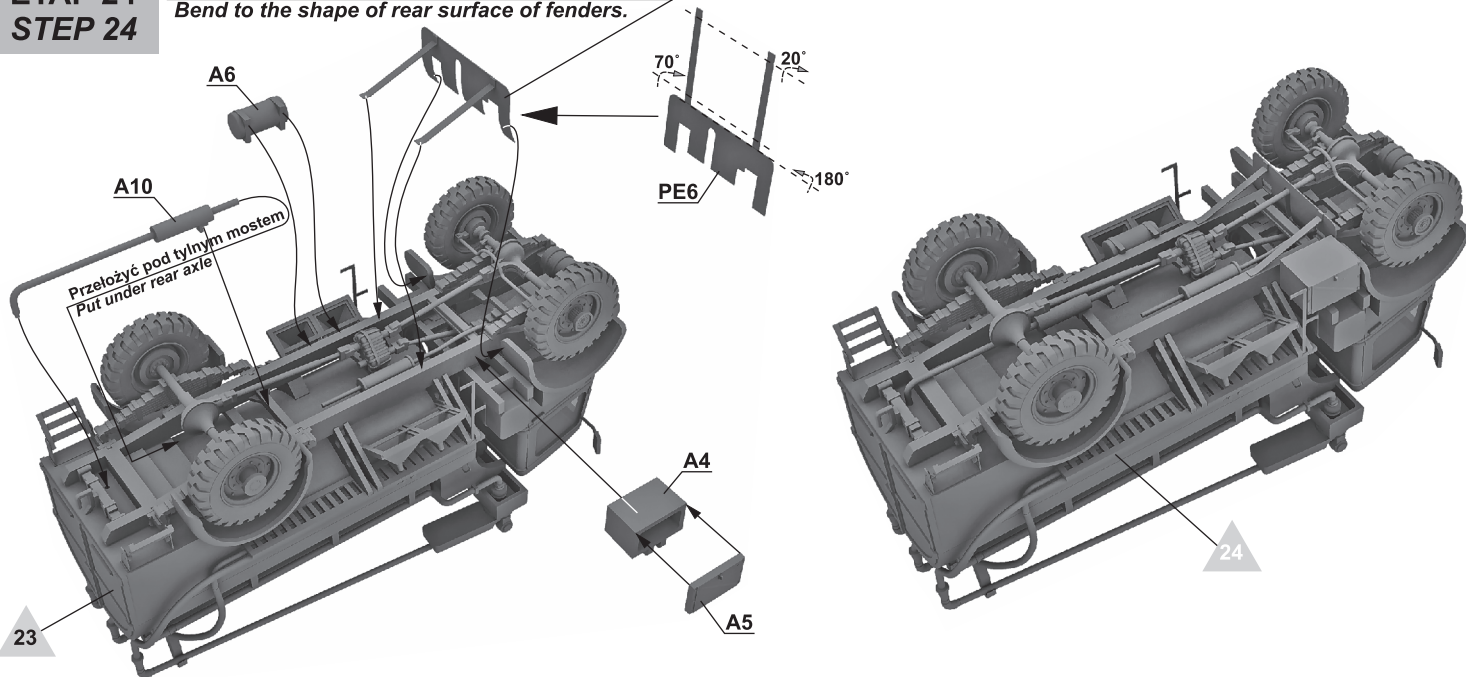

WYKONANY MODEL
FINISHED MODEL

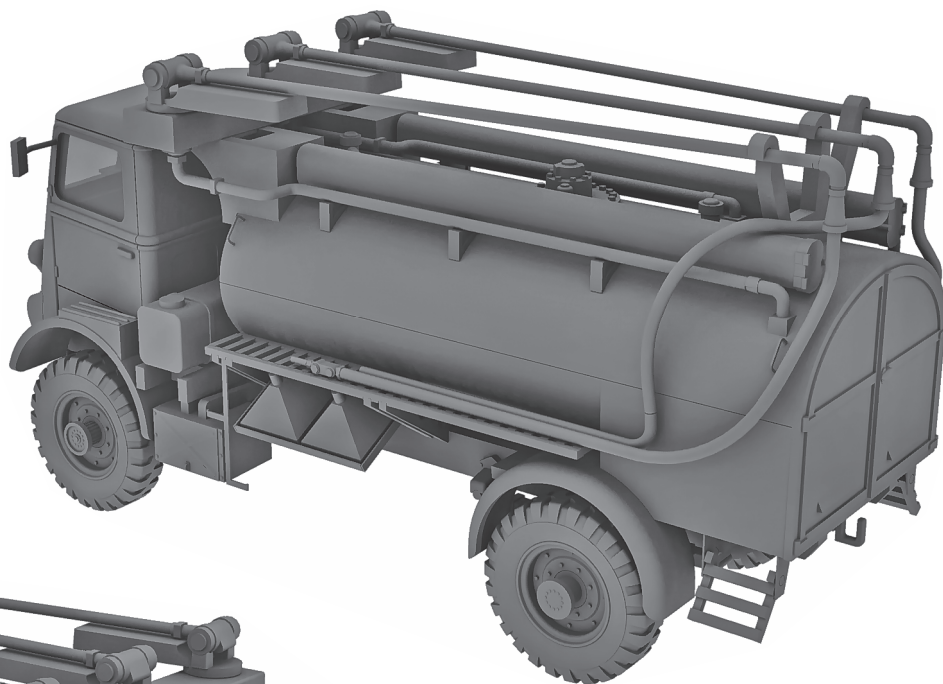

Rear left view

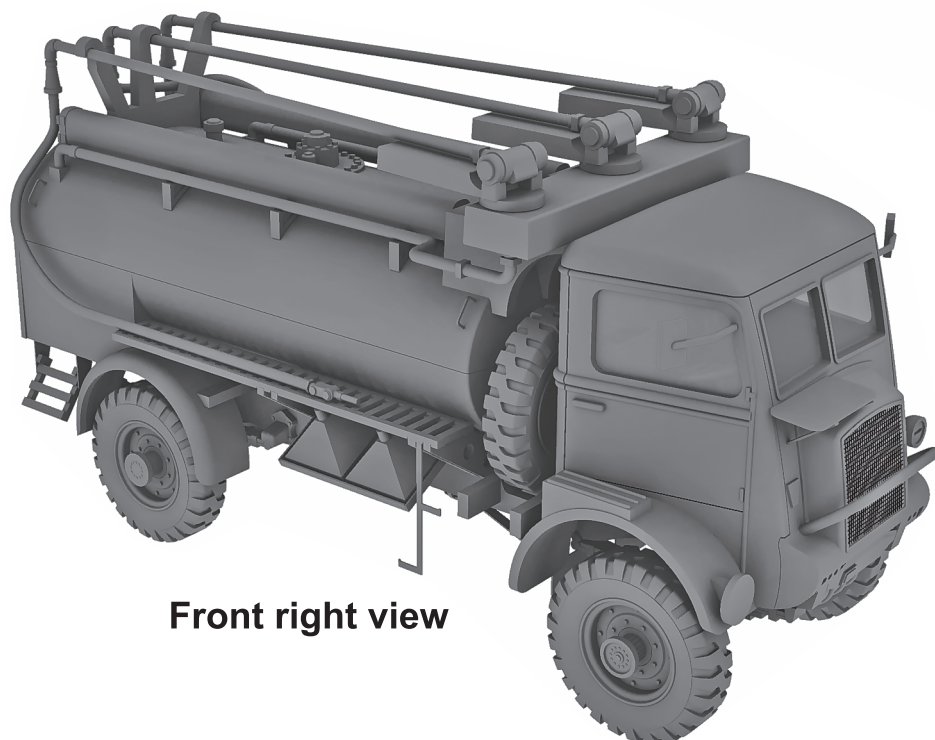

Front right view

MALOWANIE I KALKOMANIE
COLOURS AND DECALS

RAF Bedford QL Refueller powojenny, późna wersja z bomami
Niezidentyfikowana zamorska jednostka RAF, lata
pięćdziesiąte

RAF Bedford QL Post-War Refueller, late version with booms
Unidentified RAF overseas unit, 1950's

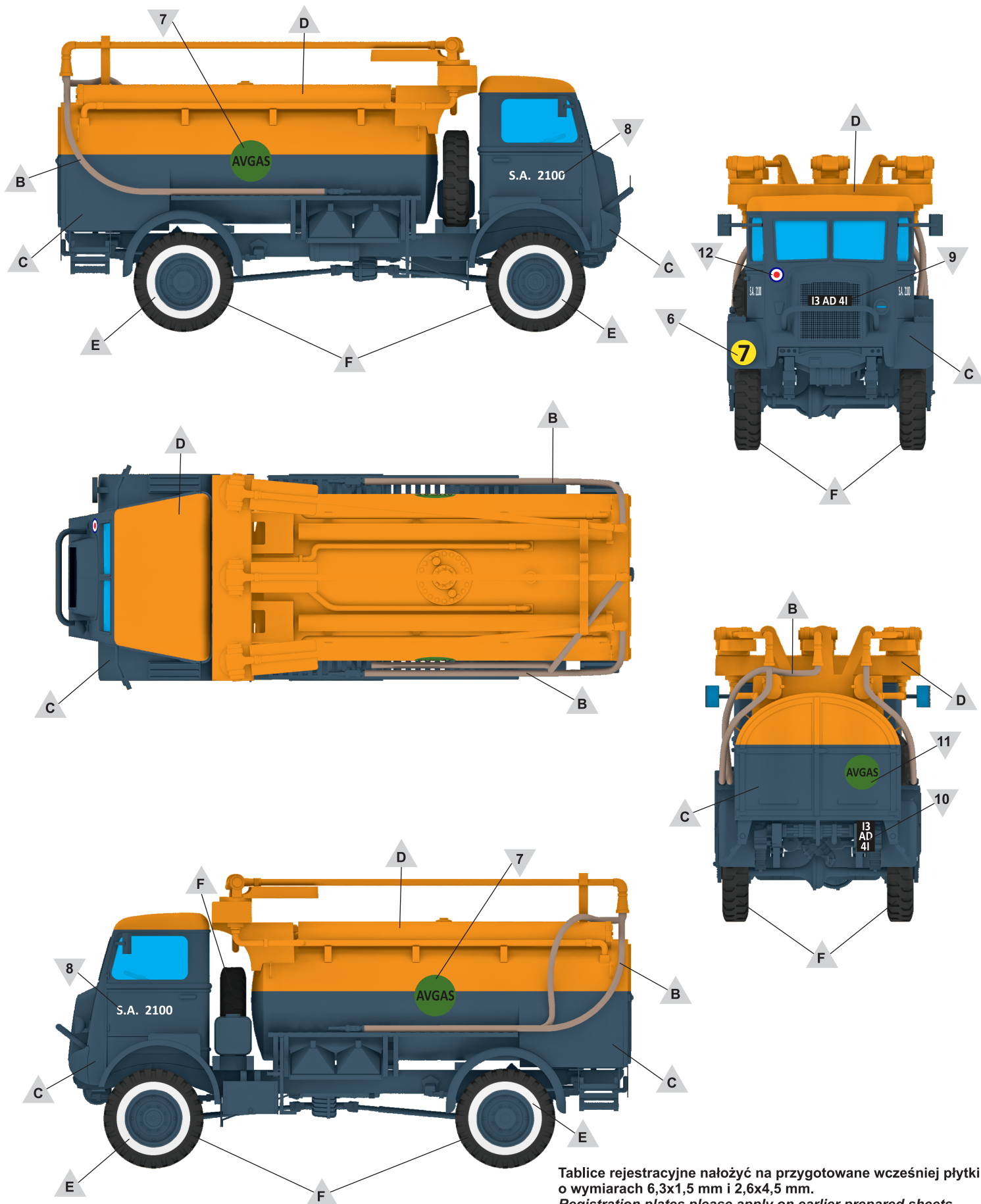

Tablice rejestracyjne nałożyć na przygotowane wcześniej płytki
o wymiarach 6,3x1,5 mm i 2,6x4,5 mm.
*Registration plates please apply on earlier prepared sheets
with dimensions 6,3x1,5 mm & 2,6x4,5 mm.*

MALOWANIE I KALKOMANIE
COLOURS AND DECALS

RAF Bedford QL Refueller powojenny, późna wersja z bomami
17 Dywizjon Royal Air Force
Wielka Brytania, baza RAF w Chivenor, 1949
RAF Bedford QL Post-War Refueller, late version with booms
17 Squadron Royal Air Force
Great Britain, RAF base Chivenor, 1949

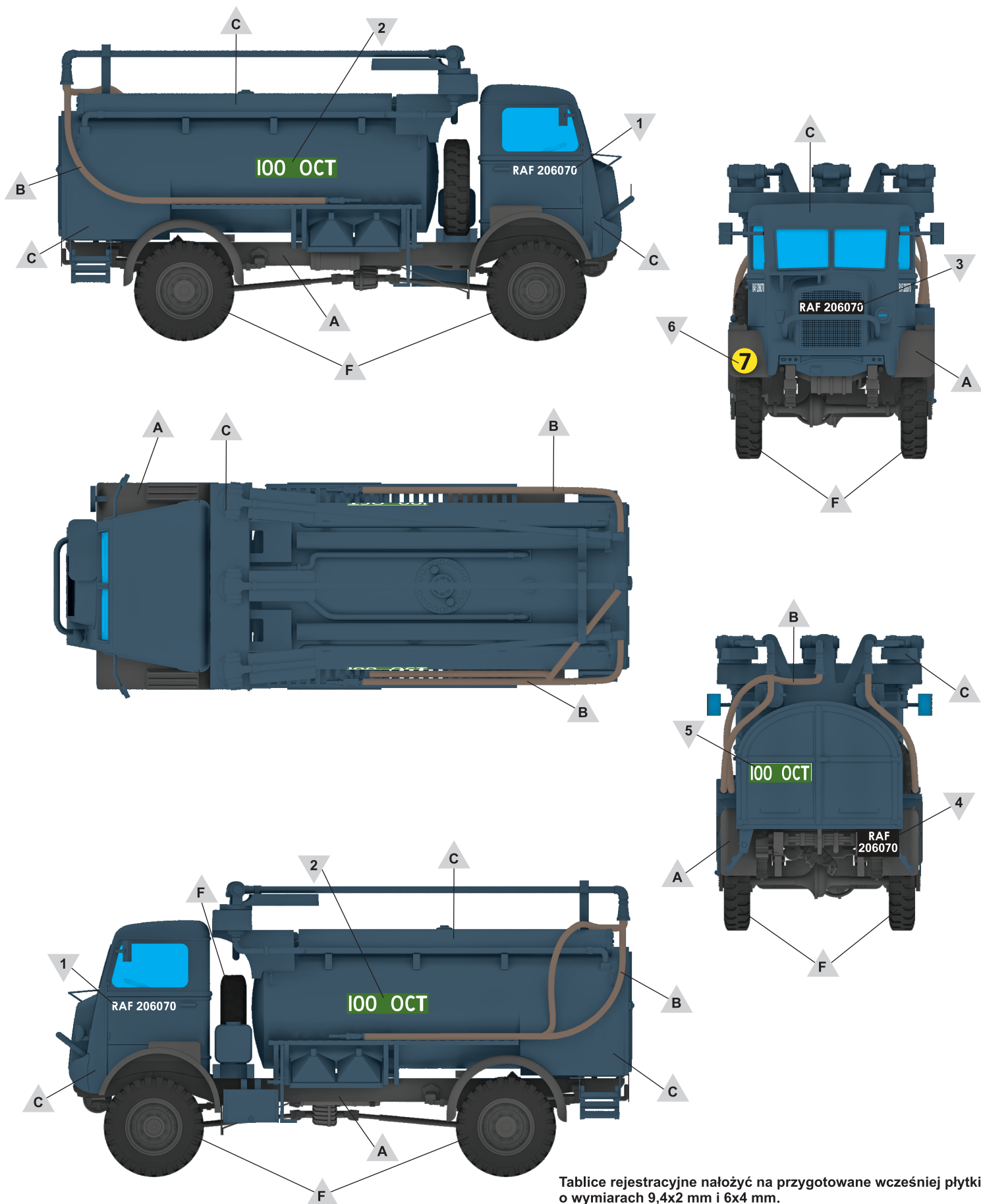

Tablice rejestracyjne nałożyć na przygotowane wcześniej płytki
o wymiarach 9,4x2 mm i 6x4 mm.
Registration plates please apply on earlier prepared sheets
with dimensions 9,4x2 mm & 6x4 mm.