

## PLASTIC PARTS

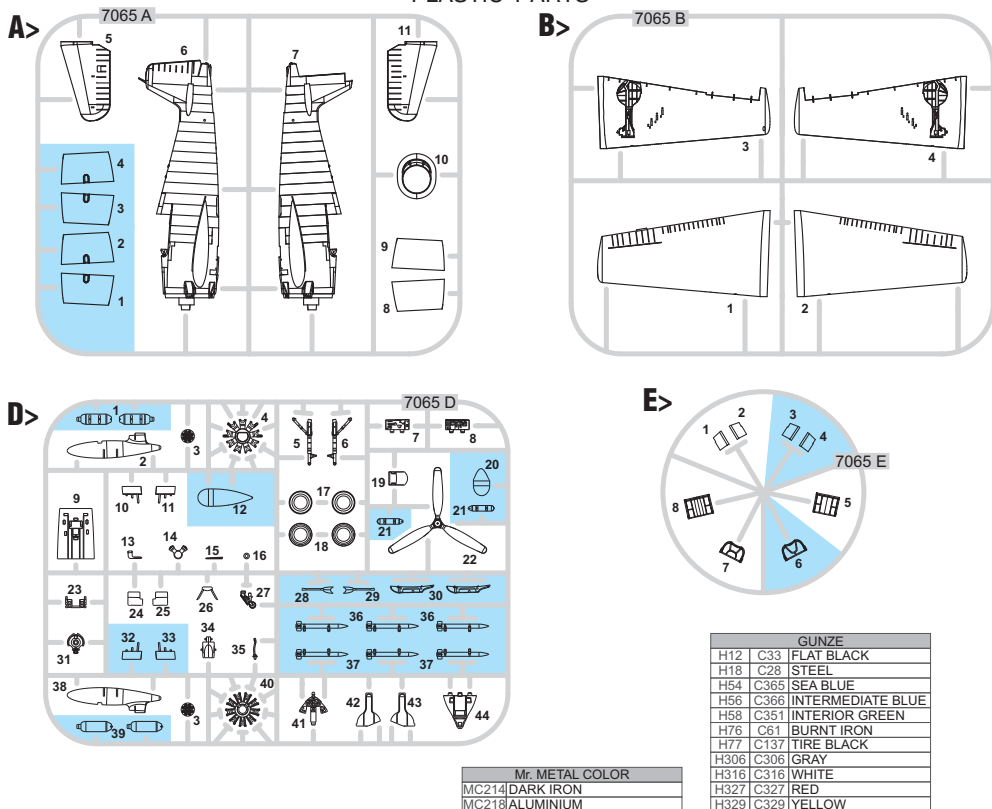

-Parts not for use. -Telle werden nicht verwendet. -Pièces à ne pas utiliser. -Tyto díly nepoužívejte při stavbě. - 使用しない部品

## ATTENTION \* UPOZORNĚNÍ \* ACHTUNG \* ATTENTION

- (GB)** Carefully read instruction sheet before assembling. When you use glue or paint, do not use near open flame and use in well ventilated room. Keep out of reach of small children. Children must not be allowed to suck any part, or pull vinyl bag over the head.
- (CZ)** Před započatím stavby si pečlivě prostudujte stavební návod. Při používání barev a lepidel pracujte v dobře větrané místnosti. Lepidla ani barvy nepoužívejte v blízkosti otevřeného ohně. Model není určen malým dětem, mohlo by dojít k požití drobných dílů.
- (D)** Vor dem Zusammenbau die Bauanleitung gut durchlesen. Kleber und Farben nicht in der Nähe von offenem Feuer verwenden und für eine ausreichende Belüftung sorgen. Den Bausatz von kleinen Kindern fernhalten. Vermeiden Sie, dass Kinder Bauteile in den Mund nehmen oder sich Plastiktüten über den Kopf ziehen.
- (F)** lire soigneusement la fiche d'instructions avant d'assembler. Ne pas utiliser de colle ou de peinture à proximité d'une flamme nue, et aérer la pièce de temps en temps. Garder hors de portée des enfants en bas âge. Ne pas laisser les enfants mettre en bouche ou sucer les pièces, ou passer un sachet vinyl sur la tête.

## INSTRUCTION SIGNS \* INSTR. SYMBOLY \* INSTRUKTION SINNBILDEN \* SYMBOLES

- OPTIONAL VOLBA
- BEND OHNOUT
- OPEN HOLE VYVRTAT OTVOR
- SYMETRICAL ASSEMBLY SYMETRICKÁ MONTÁŽ
- REMOVE ODŘÍZNOUT
- REVERSE SIDE OTOČIT 7441 - NAV1

OPTIONAL:  
decal 5

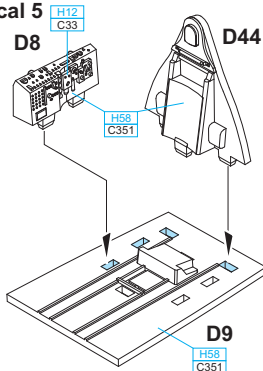

OPTIONAL:  
decal 3, 7, 8

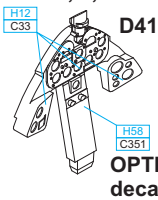

OPTIONAL:  
decal 6



decal 18

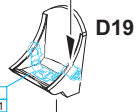

D35

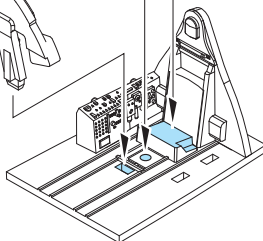

decal 17

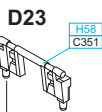

OPTIONAL:  
decal 4

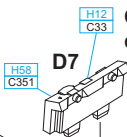

D27

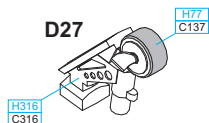

E1

A7



D27

MARKING **A** ONLY



D34

A6

E2

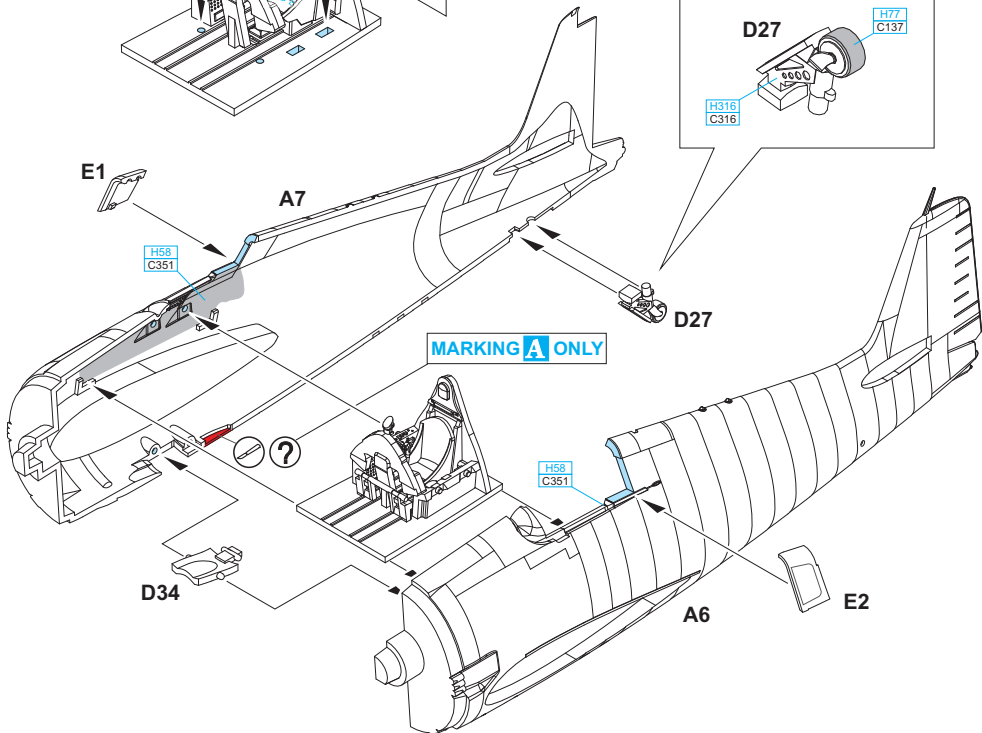

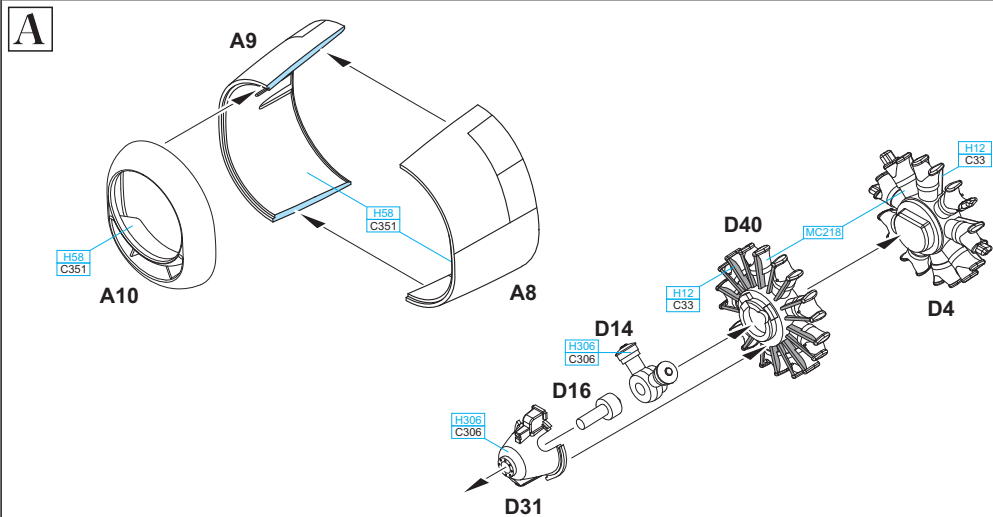
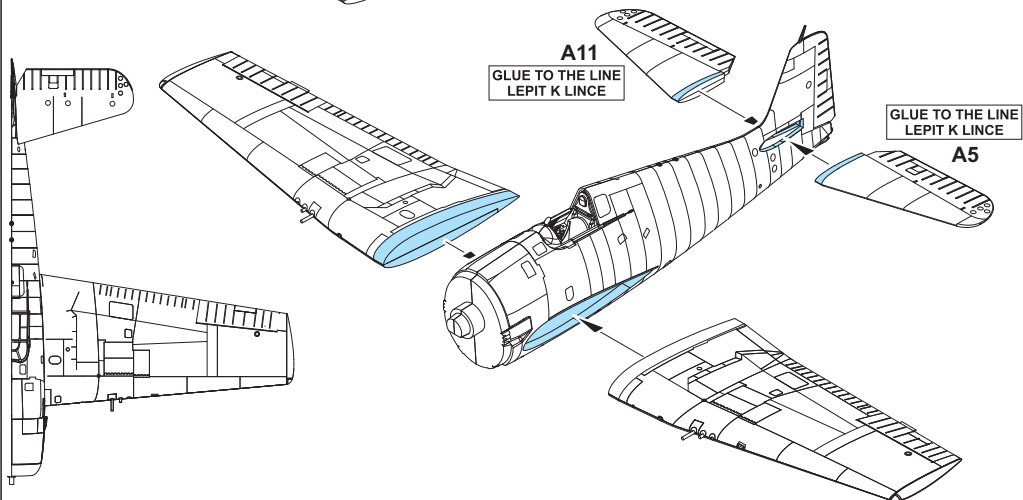
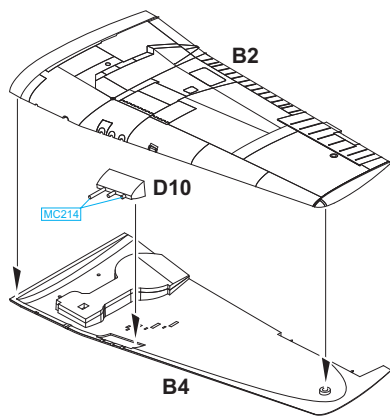
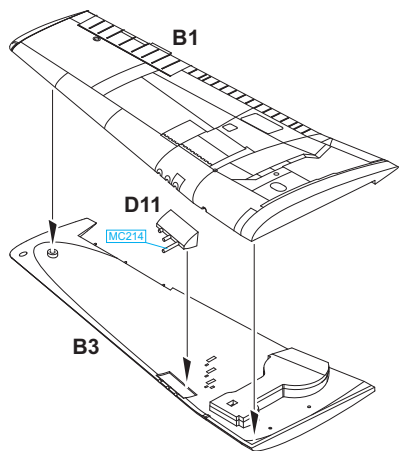

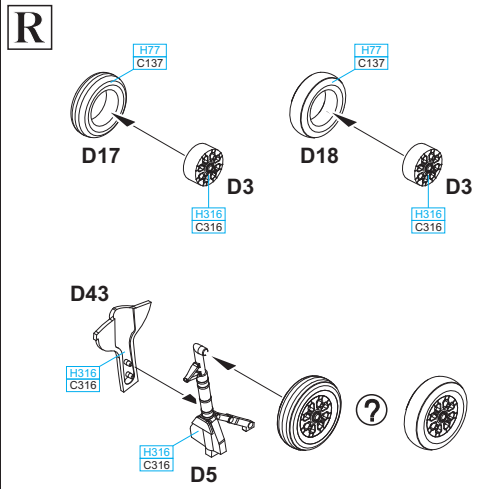
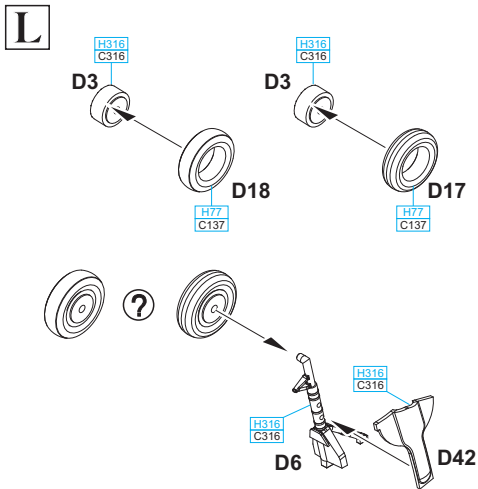
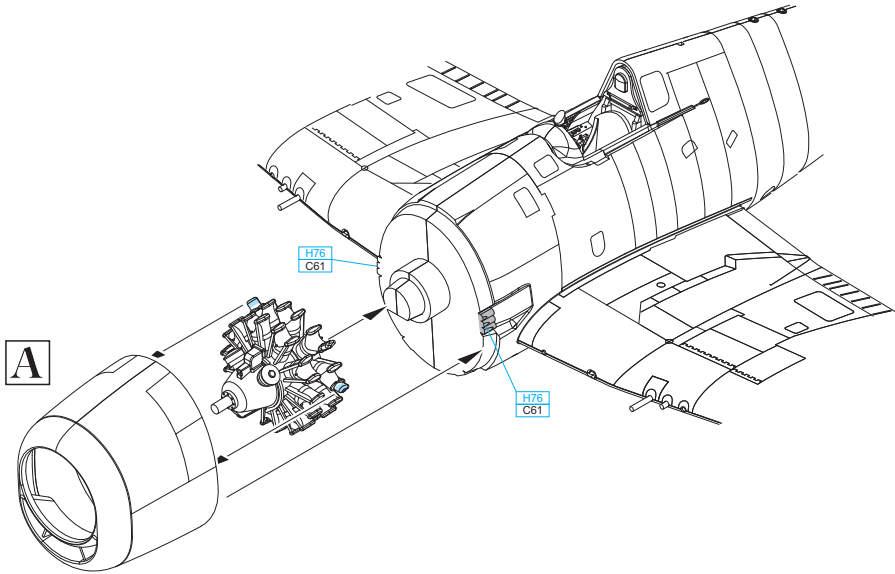

**B** MARKING A ONLY

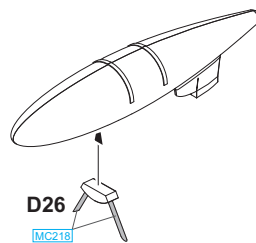
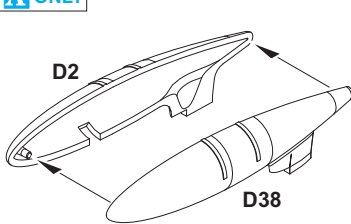

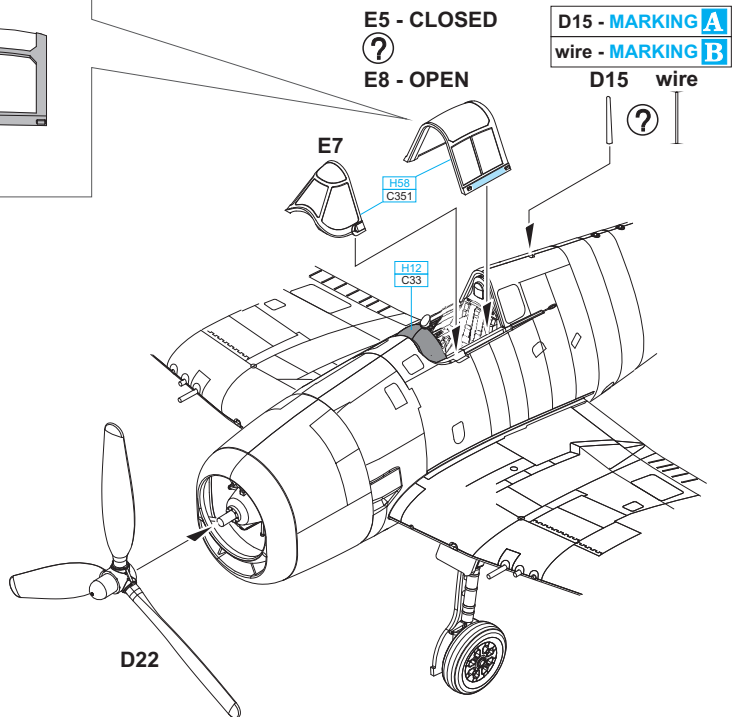
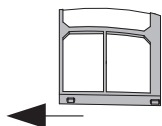
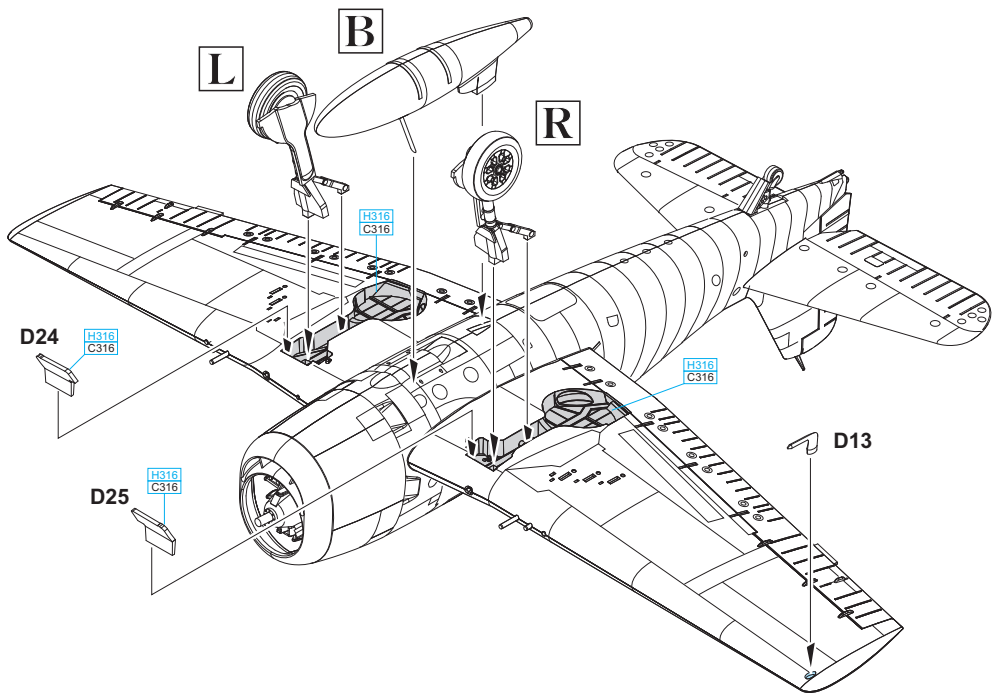



# B F6F-3, flown by Lt. Lochridge, VF-38, Guadalcanal, late 1943

The very unusual marking consisting of a white spine and part of the tail was typical for VF-38 Hellcats. Even more rare were pin-up girls on U.S. Navy fighter aircraft. VF-38 was established on June 20th, 1943 and supported the Allied advance through New Georgia and the Solomon islands. The squadron was disbanded on January 31st, 1946.

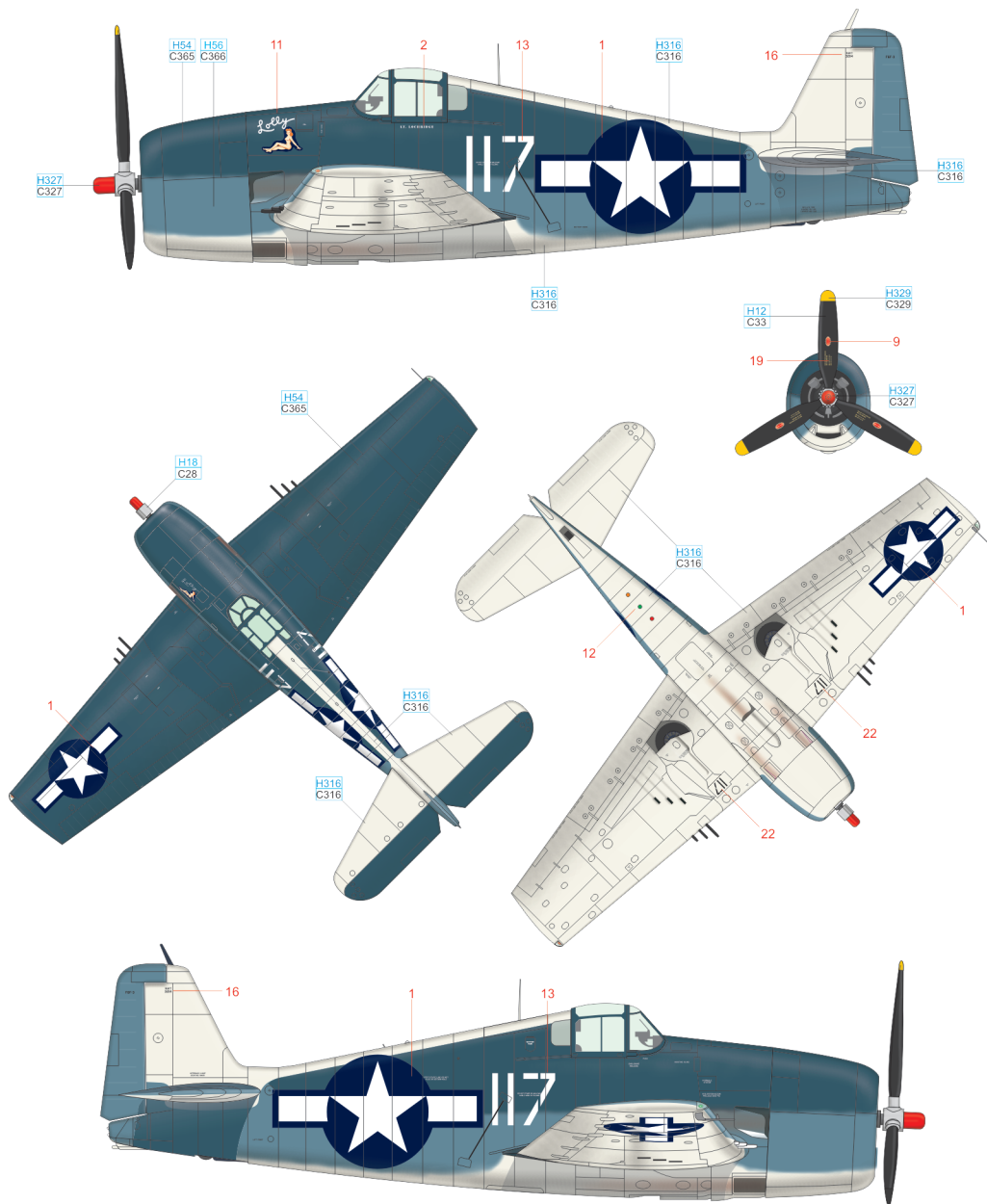

<b>YELLOW</b>	H329 C329	<b>BLACK</b>	H12 C33	<b>STEEL</b>	H18 C28
<b>WHITE</b>	H316 C316	<b>INTERMEDIATE BLUE</b>	H56 C366	<b>SEA BLUE</b>	H54 C365
			<b>RED</b>	H327 C327	

