

intro

The Avia B.534 was developed in 1934 as an extension of the B.34 fighter. In this incarnation, which was produced in small numbers for the Czechoslovak Air Force (the majority of which were attached to No.3 Fighter Regiment in Slovakia at the beginning of the Second World War), there were several engine/airframe combinations tried. The B.234 prototype served as the basis for the re-engined (Hispano Suiza 12 Ydrs for the original Avia R-29 radial) type that became the true B.534. This was the 1934 victor in a tender for a new standard fighter for the air force, and in June of that year, Avia received an order for an initial 34 aircraft. The orders accumulated to a total of 568 units, built in several production blocks.

Assessments of the aircraft are somewhat variable. At the time of its development, it was an aircraft that was technically sound and utilized progressive construction techniques, but by the time of the Munich Crisis, the technology was slowly but surely entering the realm of the obsolete. To top it off, the politics of the situation during the Crisis disallowed the chance of combat. The chance for combat missions to be flown didn't occur until a few years later, in 1941, in the services of the Slovak State, fighting for the side that had previously been the aggressor against which they were to stand. Slovak pilots flying the B.534 on the Eastern Front gained good results, and these can be viewed upon as being the climax of the career of the type. A year later, it was apparent that replacement by more modern types was necessary, and inevitable. Bulgarian attempts to combat Ploesti raiding B-24 Liberators with the B.534 was a failure, and the aging planes were not able to climb to the Liberator's operational altitudes. In Slovakia, as in Bulgaria, the type was destined for second line relegation.

Some of the remaining B.534s were destined for final operations within the Bulgarian Air Force in operations over Hungary in 1944, and with Slovakia during the several weeks long uprising against Germany (late August - early November 1944). During the Slovak National Uprising, the type was used primarily in the ground attack role, and one did manage a kill to become what is the last aerial victory of a biplane in history. It should be noted that the kill in question was that of a Hungarian transport. The fact remains that the Slovak National Uprising did end up being the swansong of the Avia B.534. Certainly, it can be said that due to the era and climate of the service of this aircraft, and the length of service it was able to achieve, the Avia B.534 has become one of the most profound symbols of Czechoslovak aviation history, a very positive symbol.

With this kit, we are introducing the Avia B.534 in its I variant. The B.534 Serie I was built to the tune of 100 units (Construction Numbers 2 to 101). They were armed with a pair of vz. 30 (Version 30) machine guns in the sides of the fuselage, and another gun on each wing in small aerodynamic gondolas. These aircraft, together with B.534 II. Serie, were accepted by the Air Force in April 1936. Due to the rising tensions with Germany, priority was given to equipping Air Regiment 1 and 4 in Bohemia, and later were allocated to units eastward, in Moravia and Slovakia.

PLASTIC PARTS

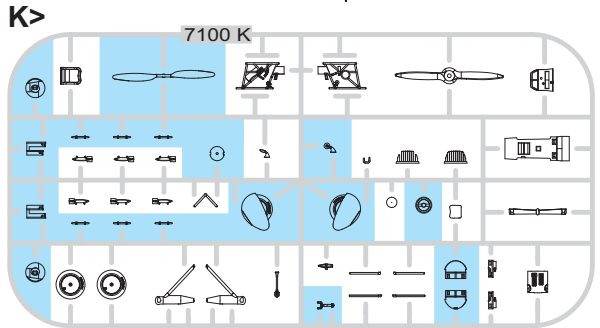
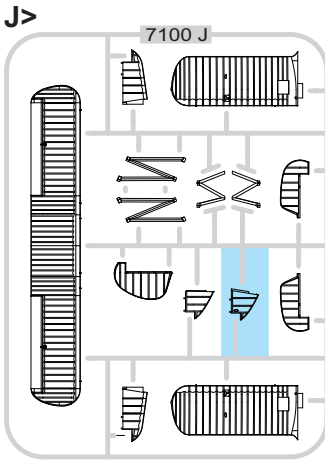
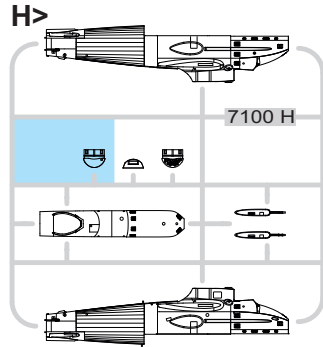
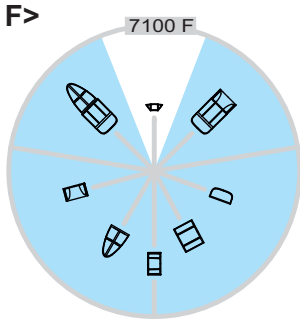

GUNZE	
H5	C5
H8	C8
H12	C33
H28	C78
H37	C43
H47	C41
H64	C17
H77	C137
H81	C55

Mr. METAL COLOR	
MC214	DARK IRON
MC215	COPPER

-Parts not for use. -Teile werden nicht verwendet. -Pièces à ne pas utiliser. -Tyto díly nepoužívejte při stavbě. - 使用しない部品

ATTENTION * UPOZORNĚNÍ * ACHTUNG * ATTENTION

- (GB)** Carefully read instruction sheet before assembling. When you use glue or paint, do not use near open flame and use in well ventilated room. Keep out of reach of small children. Children must not be allowed to suck any part, or pull vinyl bag over the head.
- (CZ)** Před započetím stavby si pečlivě prostudujte stavební návod. Při používání barev a lepidel pracujte v dobře větrané místnosti. Lepidla ani barvy nepoužívejte v blízkosti otevřeného ohně. Model není určen malým dětem, mohlo by dojít k požití drobných dílů.
- (D)** Vor dem Zusammenbau die Bauanleitung gut durchlesen. Kleber und Farben nicht in der Nähe von offenem Feuer verwenden und für eine ausreichende Belüftung sorgen. Den Bausatz von kleinen Kindern fernhalten. Vermeiden Sie, dass Kinder Bauteile in den Mund nehmen oder sich Plastiktüten über den Kopf ziehen.
- (F)** lire soigneusement la fiche d'instructions avant d'assembler. Ne pas utiliser de colle ou de peinture à proximité d'une flamme nue, et aérer la pièce de temps en temps. Garder hors de portée des enfants en bas âge. Ne pas laisser les enfants mettre en bouche ou sucer les pièces, ou passer un sachet vinyl sur la tête.

INSTRUCTION SIGNS * INSTR. SYMBOLY * INSTRUKTION SINNBILDEN * SYMBOLES

- OPTIONAL
VOLBA
- BEND
OHNOUT
- OPEN HOLE
VYVRTAT OTVOR
- SYMETRICAL ASSEMBLY
SYMETRICKÁ MONTÁŽ
- REMOVE
ODŘÍZNOUT
- REVERSE SIDE
OTOČIT

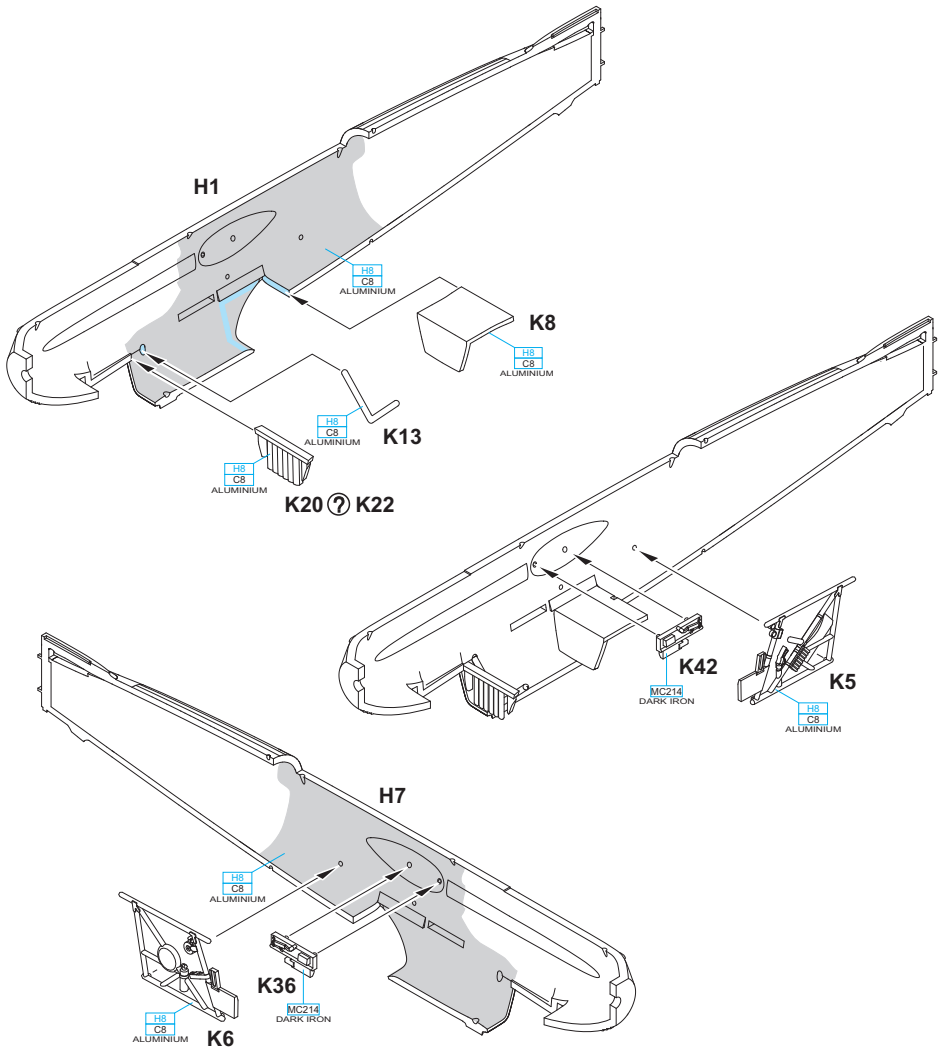

A

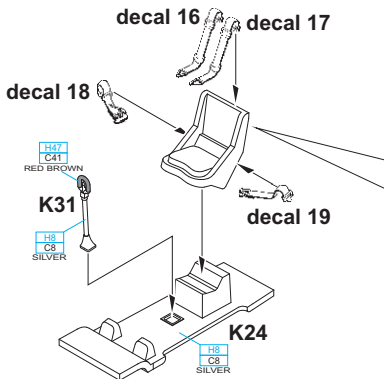

B

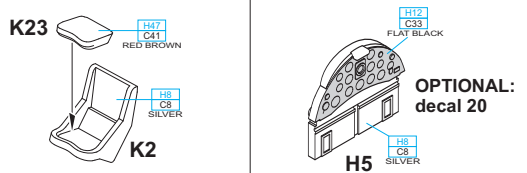

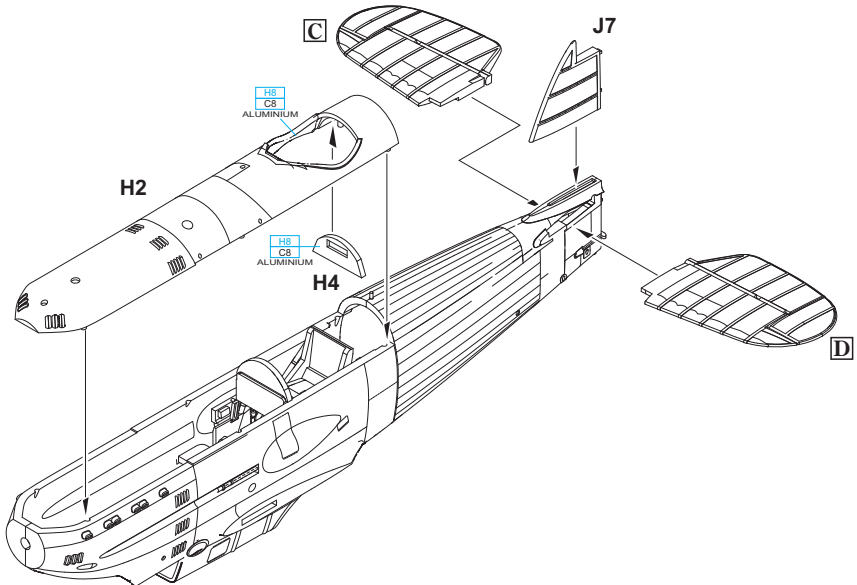
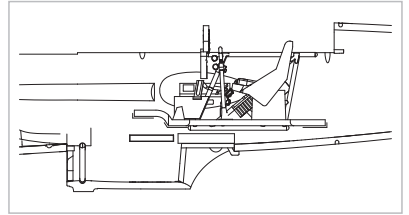
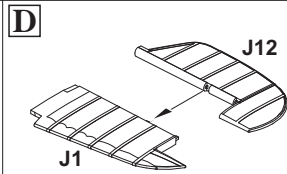
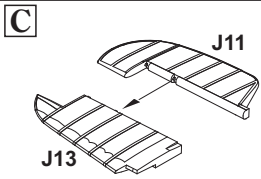
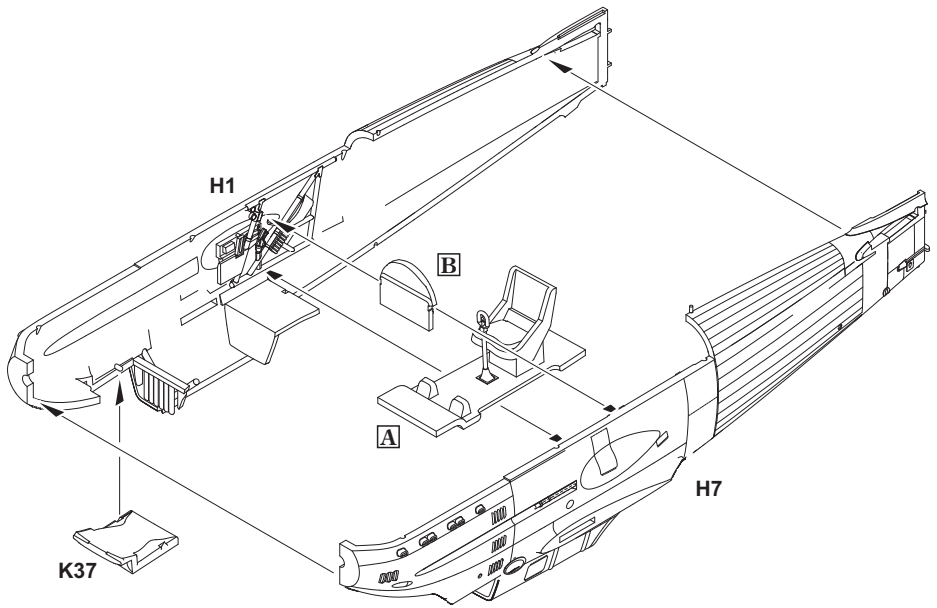

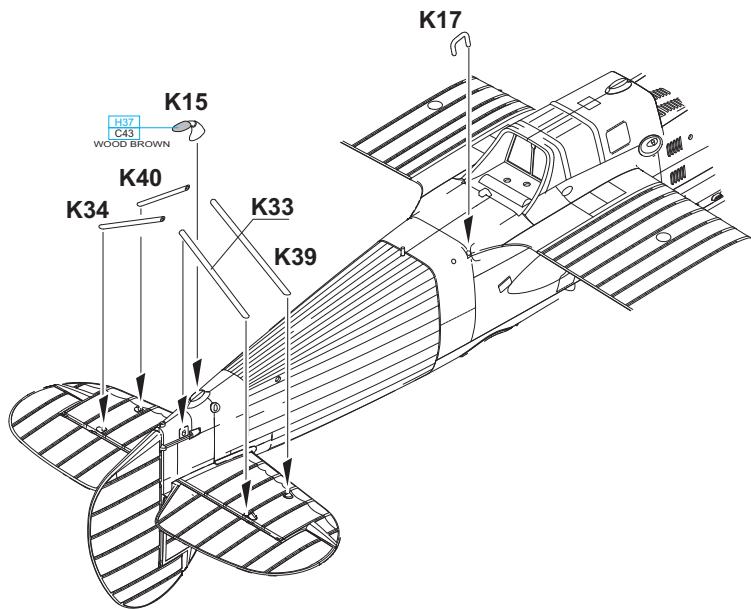
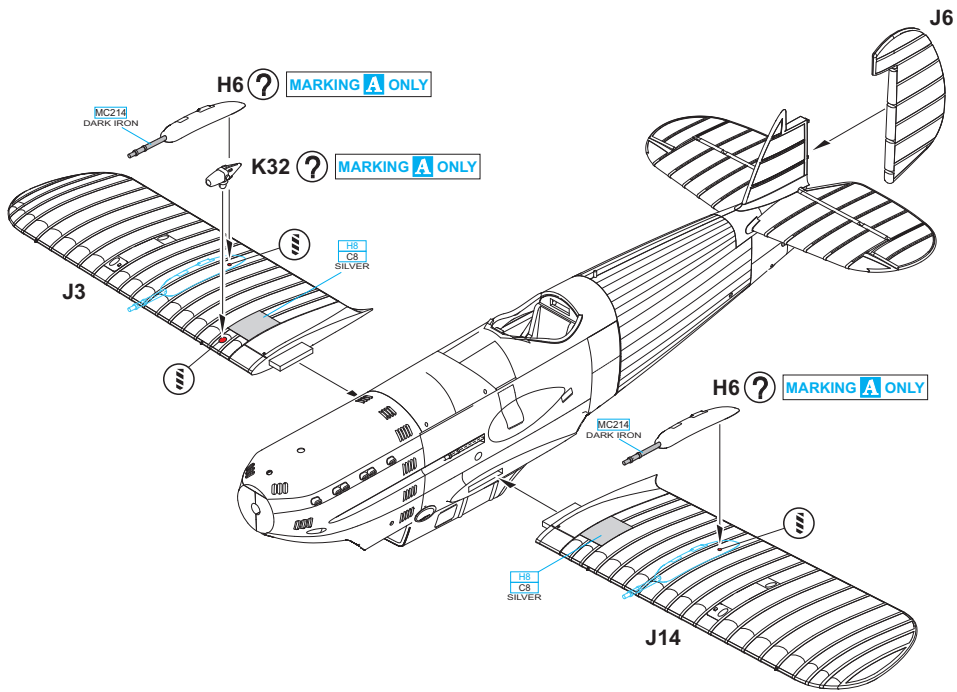

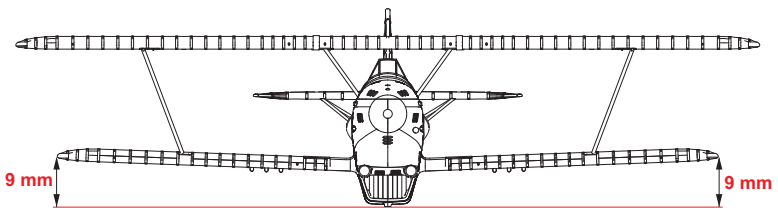
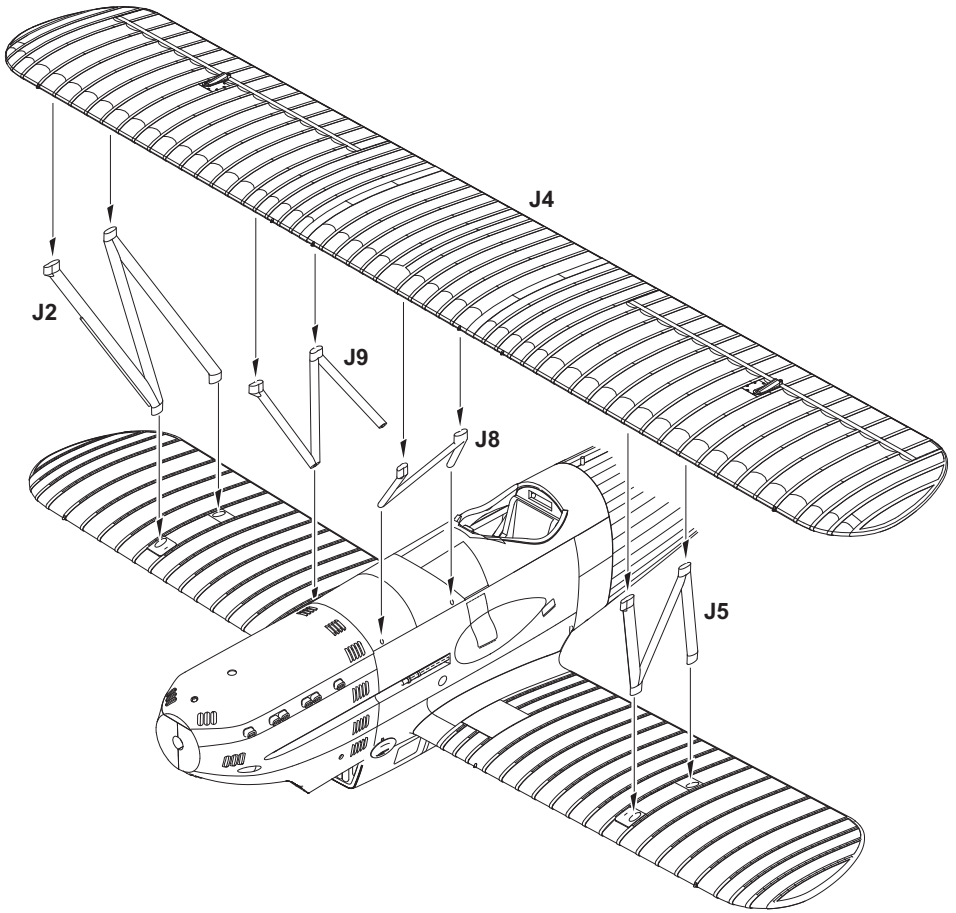

MARKING A ONLY

3 pcs. K11

H12
C33
H14
C17
FLAT BLACK DARK GREEN

K11 3 pcs.

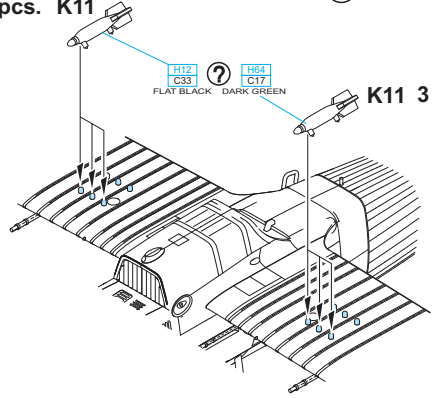

K28
K29

K25

K30

K27

MARKING B ONLY

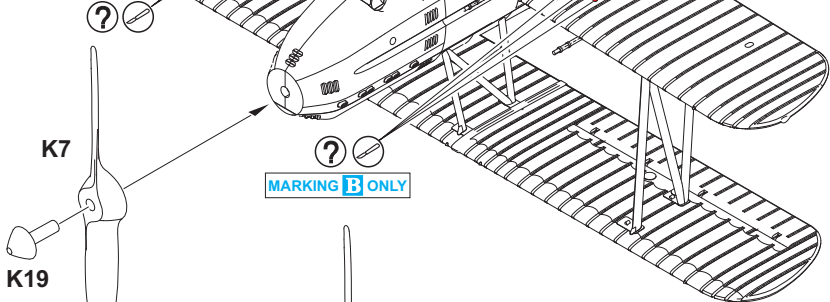

MARKING B ONLY

K7

K19

?

K7

MARKING B ONLY

decal 15

K19

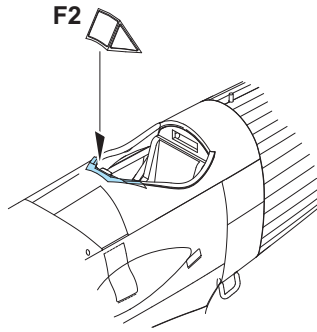

RIGGING DIAGRAM

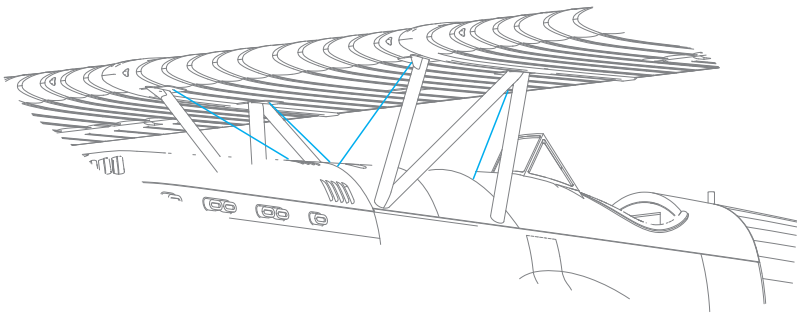

RIGGING DIAGRAM

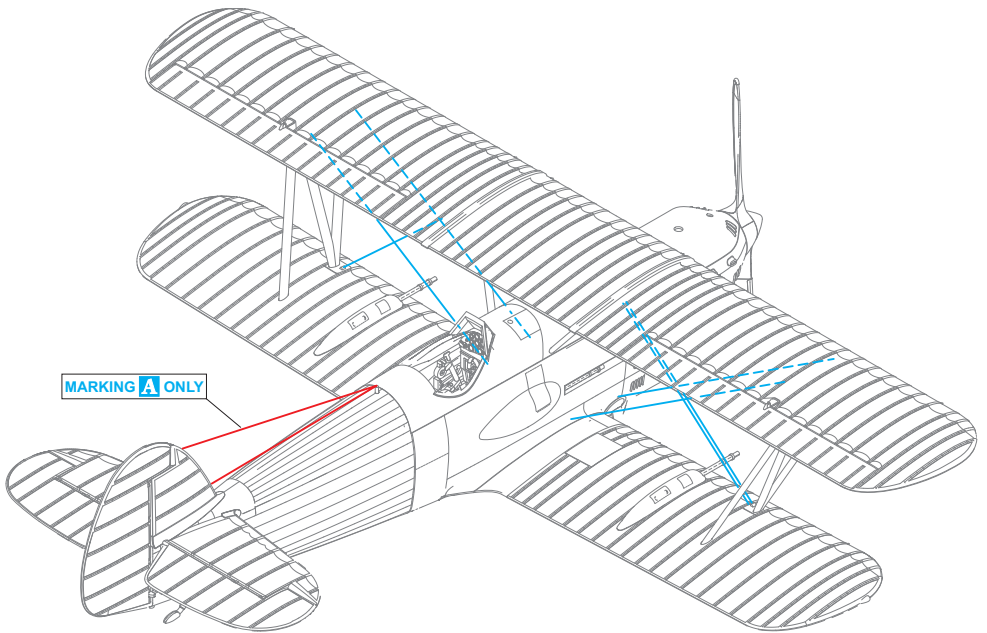
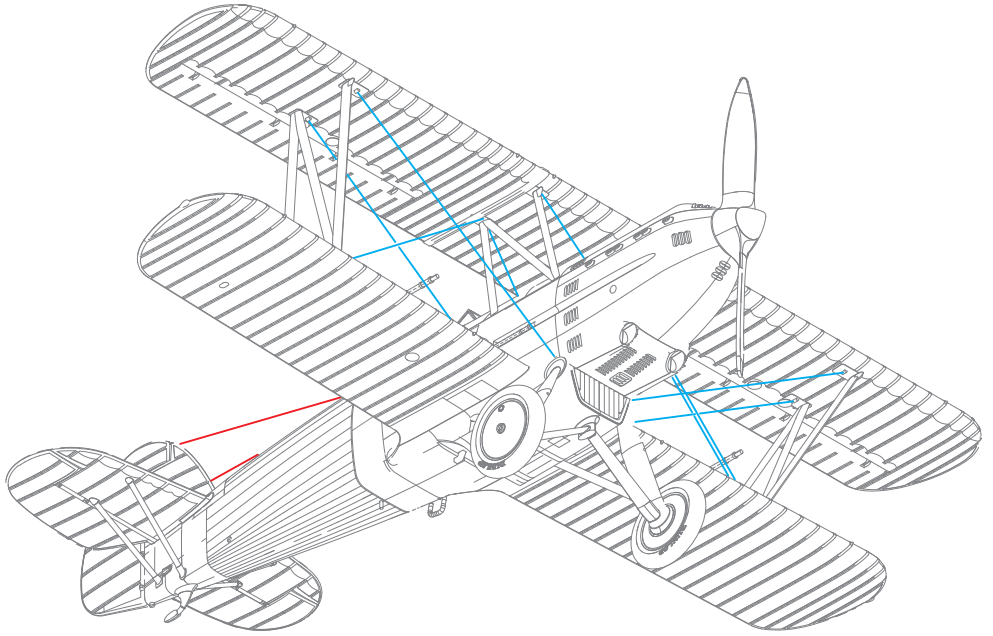

A B.534.81, 44th Fighter Squadron, Air Regiment 1, Uzhorod, June 1936

A participant in foreign combat in France, where the Ministry of National Defence saw fit to assign him to advanced aerial training in Paris, the native of Horni Cerekev Jan Pernikar flew Hurricanes in Great Britain with No.245 Squadron RAF from 1941. After this, he fulfilled several staff functions. After the German attack on the Soviet Union, he was sent to Moscow where he took part in the organization of Czechoslovak ground forces. There, he would also take part in the Slovak National Uprising. After the war, he instructed military subjects in Prague at the university level. In 1949 he was removed from duty and subsequently tried and imprisoned for a year. Then Captain Jan Pernikar suffered an accident on June 19th, 1936 flying the pictured aircraft at Uzhorod. The plane carried a khaki scheme on the side and upper surfaces and the lower surfaces were sprayed in a so-called aluminum bronze paint.

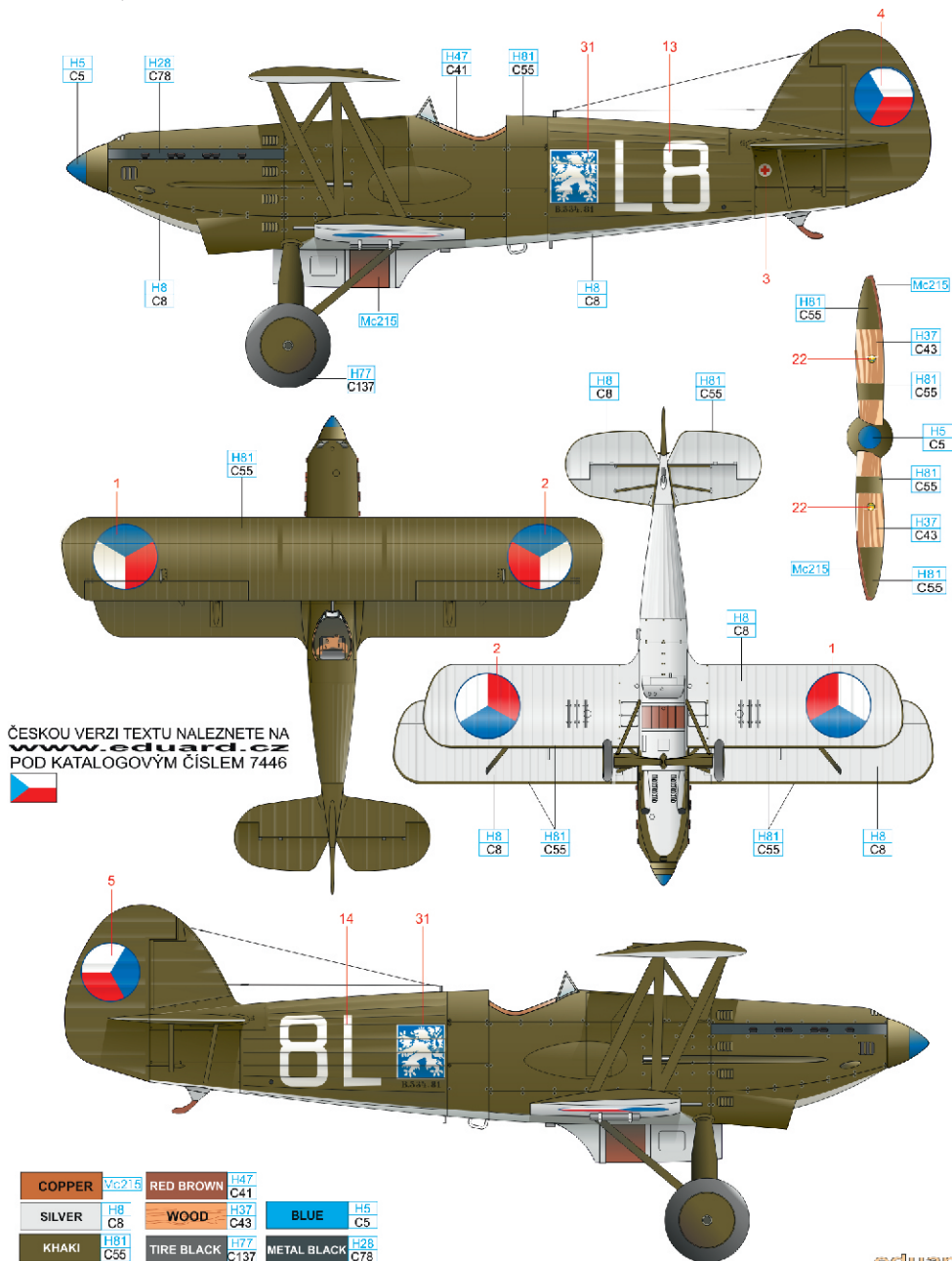

ČESKOU VERZI TEXTU NALEZNETE NA
www.eduard.cz
 POD KATALOGOVÝM ČÍSLEM 7446



COPPER	Vc215	RED BROWN	H47 C41
SILVER	H8 C8	WOOD	H37 C43
KHAKI	H81 C55	TIRE BLACK	H77 C137
		METAL BLACK	H28 C78
		BLUE	H5 C5

B B.534 I. serie, Jagdfliegerschule 4, Luftwaffe, Fürth, Germany, 1940

Pilots who completed basic training and were singled out for fighter pilot training underwent four month advanced training at one of seven Jagdfliegerschule (JFS). Here, such skills as formation flying, aerial gunnery and acrobatics were honed. The training units used a mix of German and captured aircraft from occupied countries. One of the aircraft types used by the JFS was the Avia B.534. For the mostpart, they retained their original Czechoslovak Army colour schemes. This meant they were painted khaki on the side and upper surfaces with a so-called aluminum bronze paint on the lower areas.

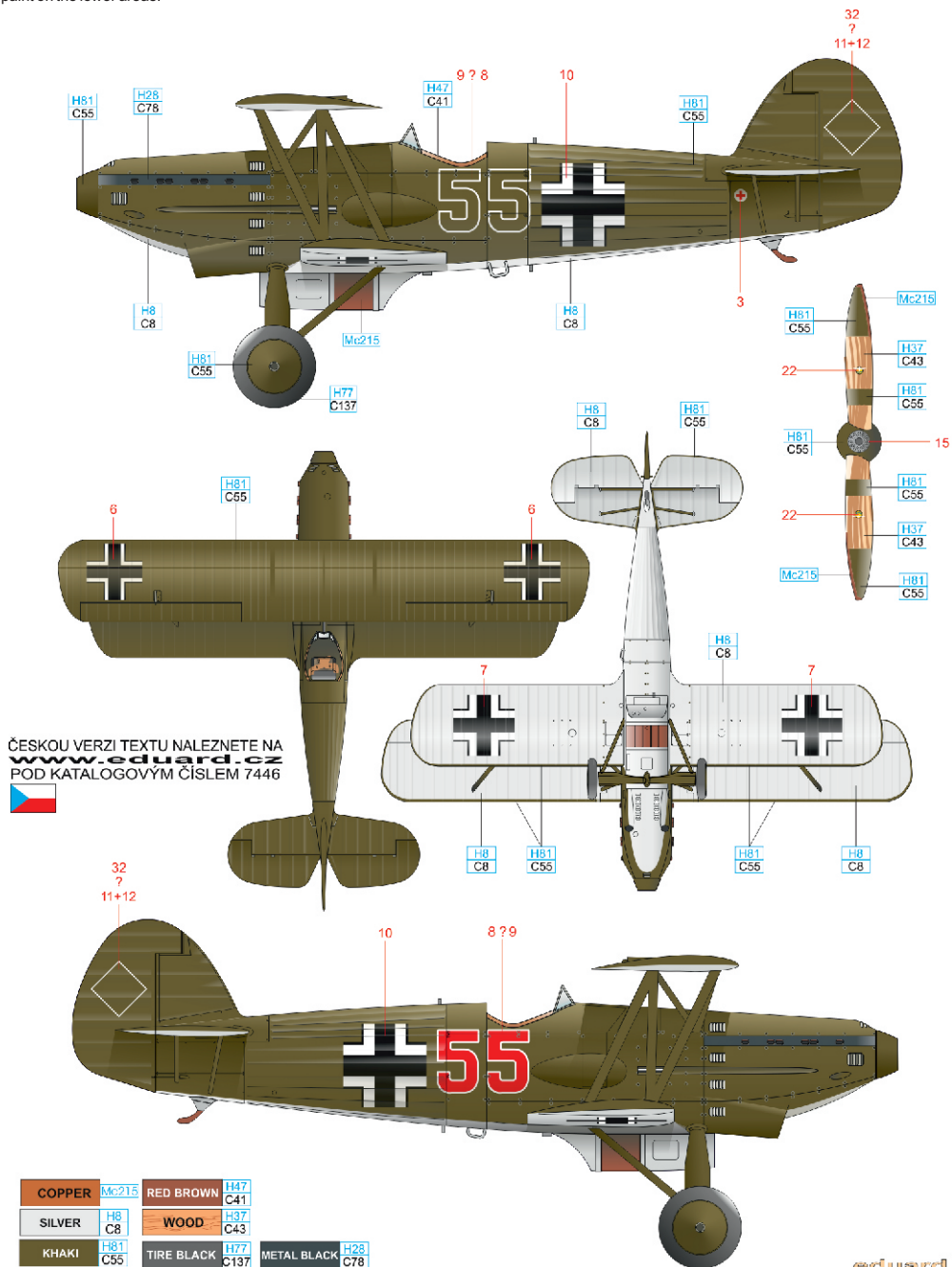

ČESKOU VERZI TEXTU NALEZNETE NA [WWW.CIA-RC.CZ](http://www.cia-rc.cz) POD KATALOGOVÝM ČÍSLEM 7446



COPPER	Mc215	RED BROWN	H47 C41
SILVER	H8 C8	WOOD	H37 C43
KHAKI	H81 C55	TIRE BLACK	H77 C137
		METAL BLACK	H28 C78

LOWER SURFACE OF TOP WING

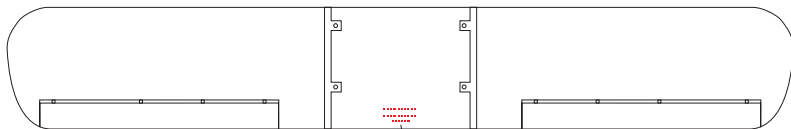

21

BENZIN. NÁDRŽ HLAV. 257 L
BENZIN. NÁDRŽ SPAD. 90 L
OLEJ. NÁDRŽ 38 L

PLNĚNÍ VODY

23

ZDE DRŽETI PŘI MOTOROVÉ ZKOUŠCE

29

PLNĚNÍ HASIČIHO PŘÍSTROJE

26

PLNĚNÍ PALIVA

28

ZDE ZVEDATI

30

PLNĚNÍ OLEJE

24

ČIŠTÍC VODY
LEVÉ HŘEBLO CHLAUČE

25

ZDE DRŽETI PŘI MOTOROVÉ ZKOUŠCE

29

SPOUŠTĚNÍ MOTORU

BRZDA

27

ZDE ZVEDATI

30