

## intro

The MiG-21 was one of a long list of Mikoyan-Gurevich products to be integrated into the armed forces of the Soviet Union, the Warsaw Pact, and allied client states. Its predecessors included such notable types as the MiG-15, MiG-17 and the supersonic MiG-19. The roots of this project reach back to the first half of the fifties. In 1954, the Ye-1 project came to an end, and was quickly picked up by the Ye-2. Both had a swept wing. The first machine to feature the delta wing was the Ye-4, which first took to the air on June 16th, 1955. It was also demonstrated a year later at the Moscow airfield in Tushino. The first of the new line to enter production was the MiG-21F, which together with the MiG-21P and F-13 represented the first generation of the MiG-21, and was in production through the end of the fifties and the beginning of the sixties. Subsequent versions of the second generation aircraft equipped with an onboard radar included the PF, FL, PFM and R, production of which which peaked at the end of the sixties. The third generation started production in 1968, which included such versions as the M, SM, MF, SMT and bis, among others. Simultaneously, two-seat training versions were also produced designated MiG-21U, UM and US. Production of the MiG-21 ended in 1985, and over the years was put into service with some fifty countries. Over the course of the cold war, the opponents of the MiG-21 included the likes of the Northrop F-5 Freedom Fighter and the Dassault Mirage III. NATO assigned it the reporting name 'Fishbed'. It became the most produced supersonic fighter in terms of quantity. The new machines came off Soviet production lines in Moscow, Gorky and Tbilisi. The MiG-21F-13 was also built under license in Czechoslovakia and the MiG-21FL, M and bis in India by Hindustan Aeronautics Ltd. The Soviet Union produced 10,645 examples of all versions, 194 were built in Czechoslovakia and 657 in India. Outside of the Soviet Union, the type flew with a long list of nations on all continents with the exception of Australia. The MiG-21 participated in combat in Vietnam, the Indo-Pakistan wars, the Cuban participation in Angola and in the Arab world's attempt to eliminate Israel. MiG-21 of various versions became famous also thanks to the wide use by the North Vietnamese AF during the Vietnam War. Thanks to the high volume of use, the highest number of fighter aces produced on the type was in Vietnam. The type was used as an interceptor with the Soviet Union and other members of the Warsaw Pact into the eighties, when it began to be displaced by the MiG-29 Fulcrum.

You can build the MiG-21PF from this kit, the second generation of the MiG-21. The first second generation type was the MiG-21P, introduced in 1960, followed by the MiG-21PF, produced from 1962 until 1968 at the Gorky and Moscow production plants. The MiG-21PF, as well as the MiG-21P, was developed as an air superiority fighter. Unlike the first generation MiG-21Fs, the second generation aircraft were equipped with an onboard TSD-30T (RP-21M Safir) radar. The cannon was removed, the only weapons being a pair of RS-2US or R-3S AA missiles. The design featured wider wheels, and rocket assisted take-off allowed operations from frontline airfields. Latter development led to the MiG-21PFM with modernized wing, simultaneously produced from 1963 until 1968. The NATO code name for the MiG-21PF was Fishbed D.

ATTENTION



UPOZORNĚNÍ



ACHTUNG



ATTENTION



注意



Carefully read instruction sheet before assembling. When you use glue or paint, do not use near open flame and use in well ventilated room. Keep out of reach of small children. Children must not be allowed to suck any part, or pull vinyl bag over the head.



Před započítím stavby si pečlivě prostudujte stavební návod. Při používání barev a lepidel pracujte v dobře větrané místnosti. Lepidla ani barvy nepoužívejte v blízkosti otevřeného ohně. Model není určen malým dětem, mohlo by dojít k požití drobných dílů.

INSTRUCTION SIGNS

✳ INSTR. SYMBOLY

✳ INSTRUKTION

✳ SINNBILDEN

✳ SYMBOLES

✳ 記号の説明

OPTIONAL  
VOLBABEND  
OHNOUTSAND  
BROUSITOPEN HOLE  
VYVRTAT OTVORSYMMETRICAL ASSEMBLY  
SYMETRICKÁ MONTÁŽREMOVE  
ODRŽNOUTREVERSE SIDE  
OTOCITAPPLY EDUARD MASK  
AND PAINT  
POUŽIT EDUARD MASK  
NABARVIT

PARTS



DÍLY



TEILE



PIÈCES



部品

## PLASTIC PARTS

C&gt;

70140 C

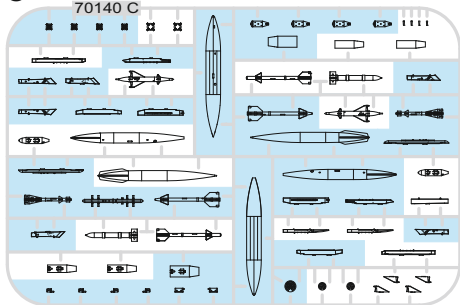

D&gt;

70140 D

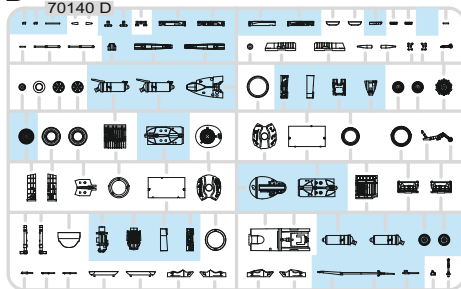

G&gt;

70140 G

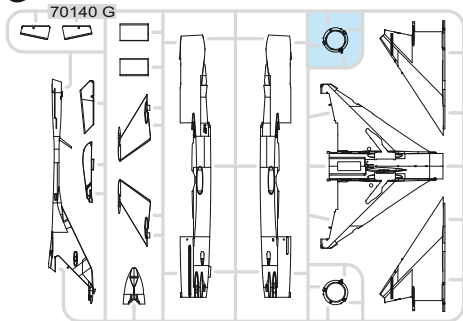

H&gt;

70140 H

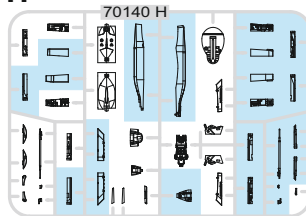

I&gt;

70140 I

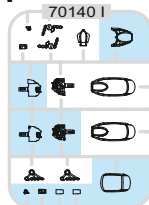

-Parts not for use. -Teile werden nicht verwendet. -Pièces à ne pas utiliser. -Tyto díly nepoužívejte při stavbě. - 使用しない部品

COLOURS



BARVY



FARBEN



PEINTURE



色

GSI Creos (GUNZE)		MISSION MODELS	
AQUEOUS	Mr.COLOR	PAINTS	
H1	C1	[MMP-001]	WHITE
H3	C3	[MMP-003]	RED
H4	C4	[MMP-007]	YELLOW
H5	C5	[MMP-048]	BLUE
H11	C62	[MMP-001]	FLAT WHITE
H12	C33	[MMP-047]	FLAT BLACK
H18	C66		BRIGHT GREEN
H22	C66		TAN
H47	C41	[MMP-012]	RED BROWN
H51	C11	[MMP-063]	LIGHT GULL GRAY
H57	C115	[MMP-057]	LIGHT BLUE
H70	C60	[MMP-056]	GRAY
H77	C137	[MMP-040]	TIRE BLACK
H81	C55	[MMP-023]	KHAKI
H84	C42		MAHOGANY
H90	C47		CLEAR RED

GSI Creos (GUNZE)		MISSION MODELS	
AQUEOUS	Mr.COLOR	PAINTS	
H94	C138		CLEAR GREEN
H105	C305	[MMP-084]	GRAY
H109	C308		GRAY
H113	C315		GRAY
H132	C332		LIGHT AIRCRAFT GRAY
H137	C337		GRAYISH BLUE
H122	C122	[MMP-053]	LIGHT GREEN
	C136	[MMP-032]	RUSSIAN GREEN
	C391		INTERIOR TURQUOISE GREEN
Mr.METAL COLOR		METALLICS	
[M213]		[MMA-006]	STEEL
[M216]		[MMA-001]	DARK IRON
[M218]		[MMA-003]	ALUMINIUM
Mr.COLOR SUPER METALLIC		METALLICS	
[SM201]		[MMC-001]	SUPER FINE SILVER

**1** = 

H70 MMP	- MARKING A
CB0 056	GRAY

S3201	- MARKING B
MMC 001	FINE SILVER

**2** = 

C391	- MARKING A
INT. GREEN	

H308 MMP	- MARKING B
C308 073	GRAY

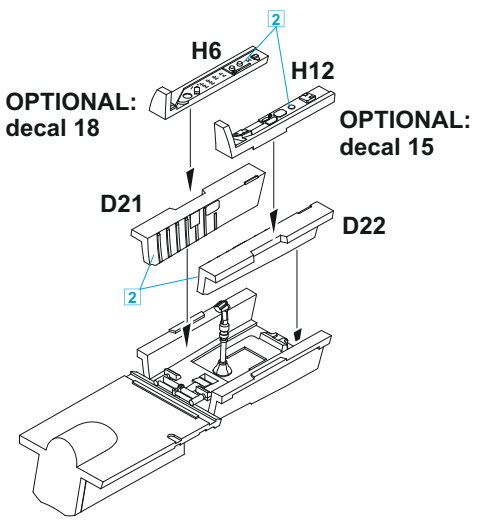
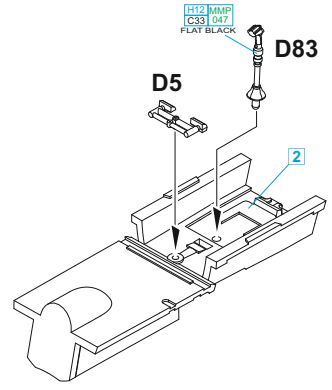
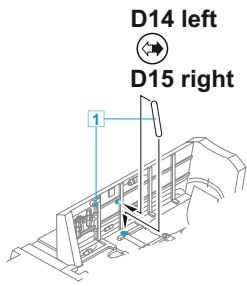
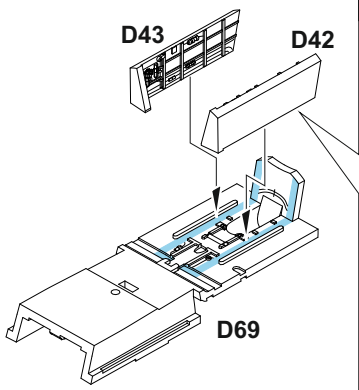

C391	- MARKING A ONLY
INT. GREEN	



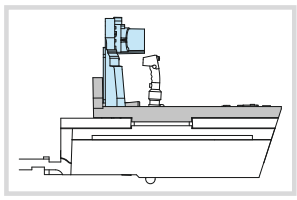
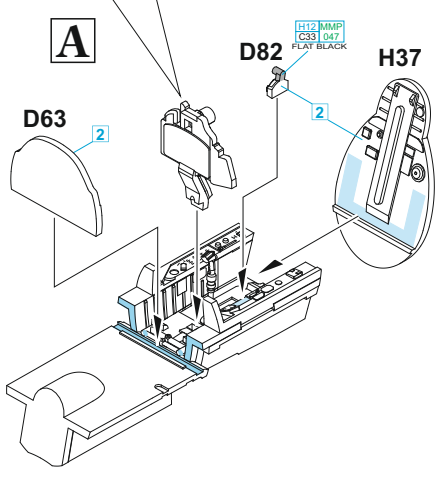
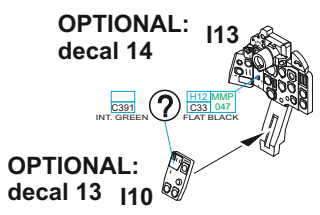

D46

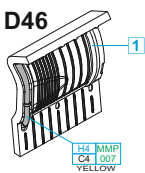

**B**

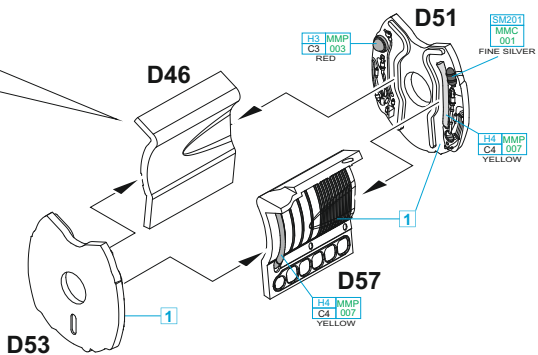

D54

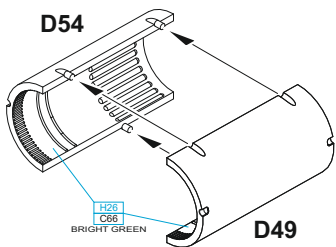

**C**

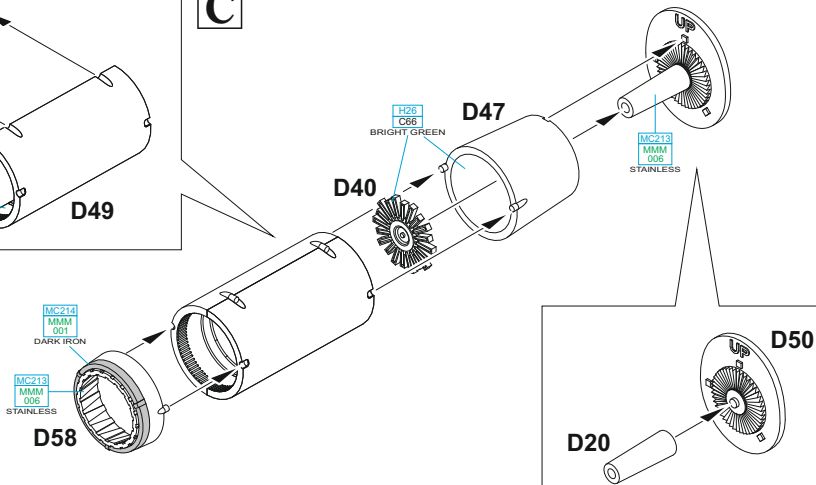

G12

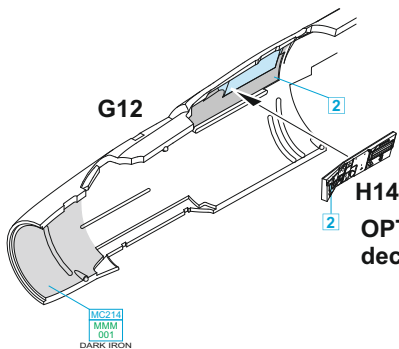

H14  
OPTIONAL:  
decal 17

G11

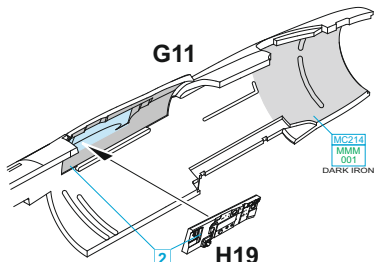

H19  
OPTIONAL:  
decal 16

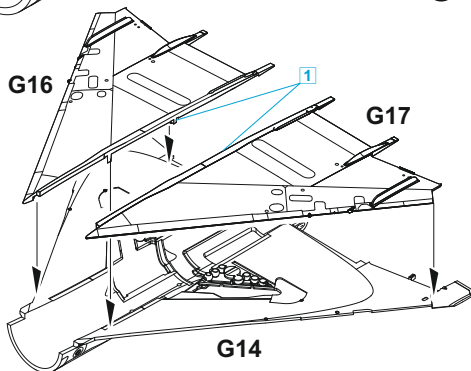
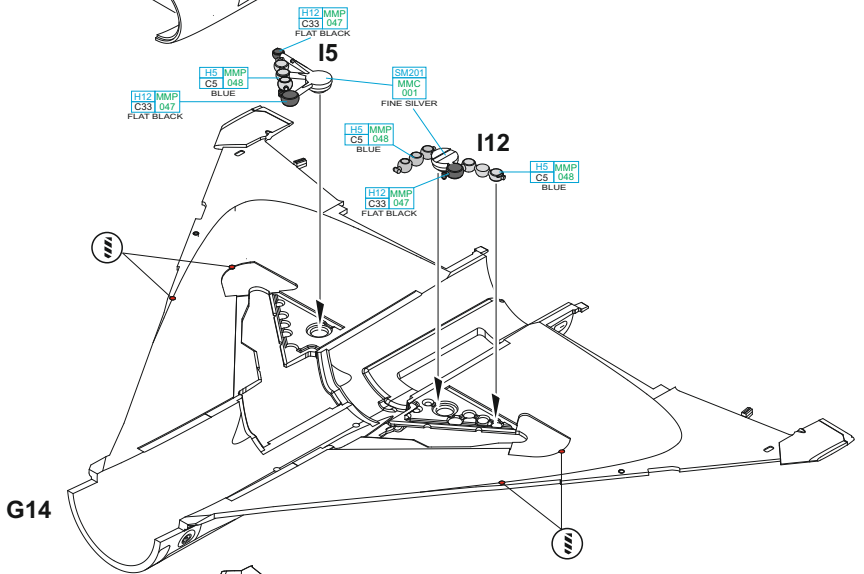
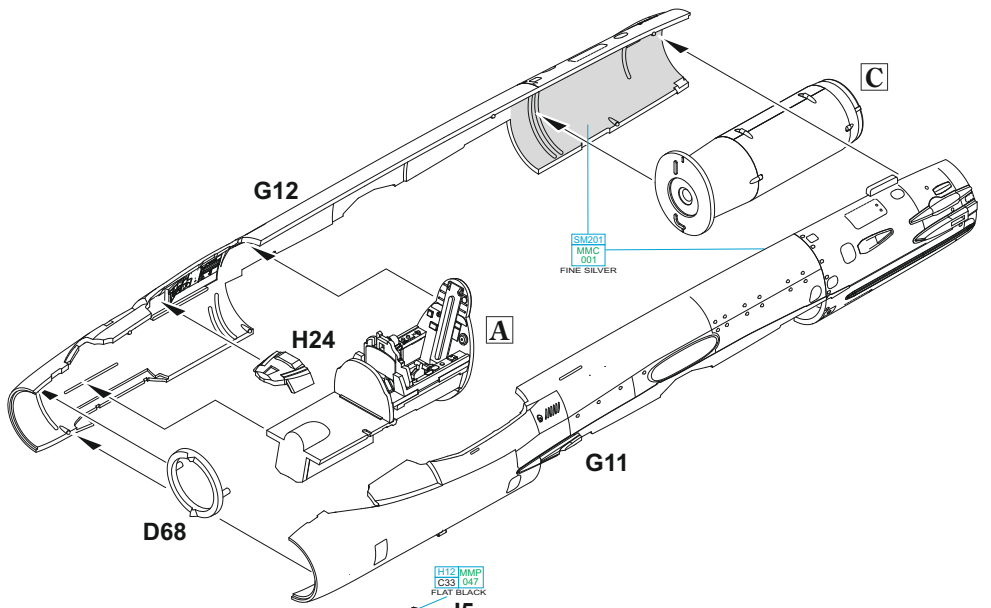

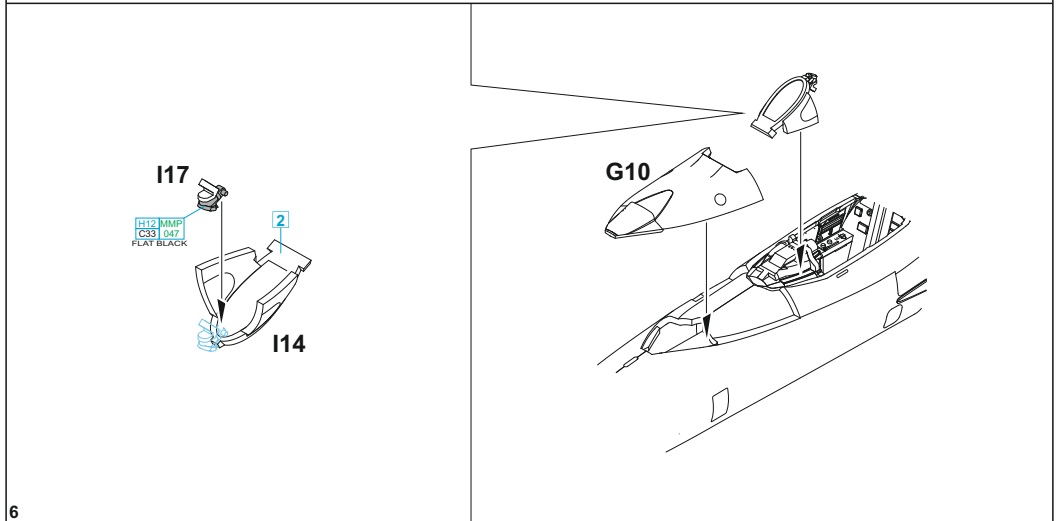
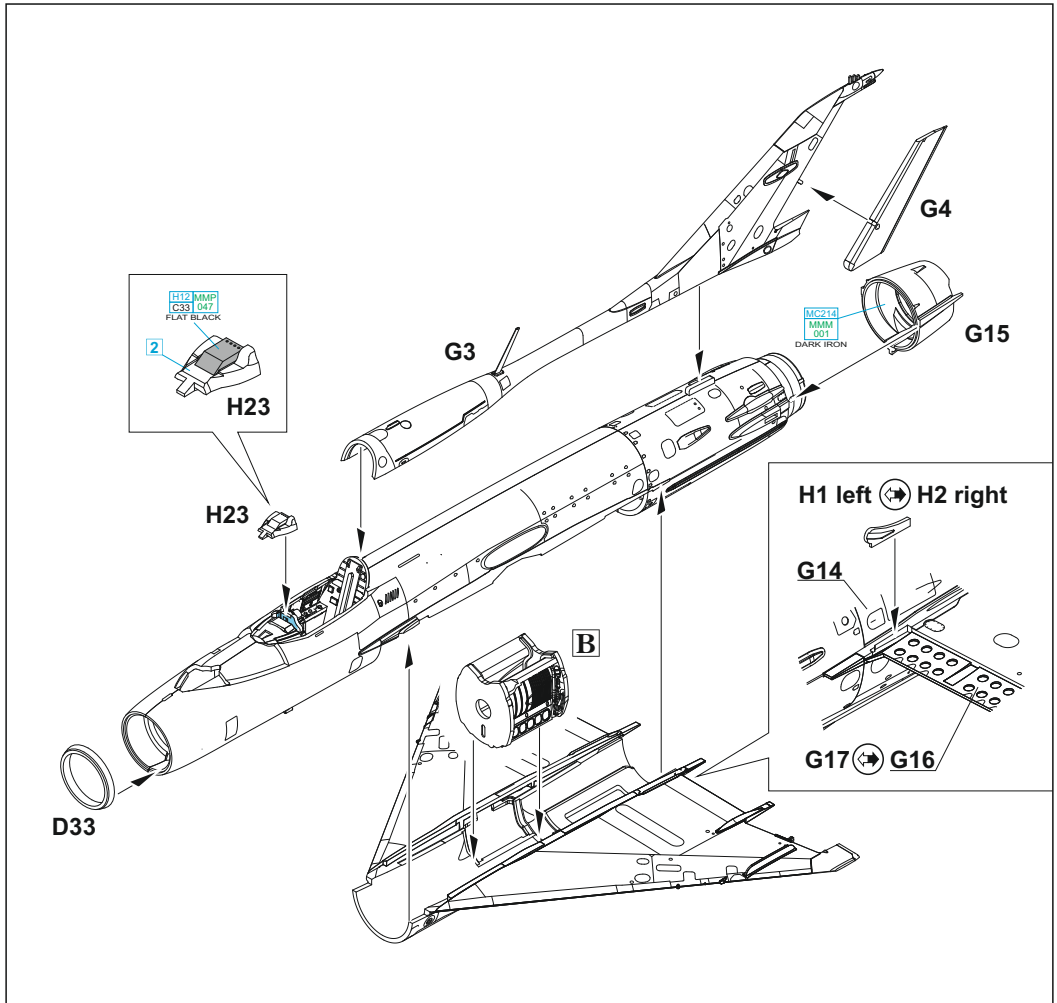

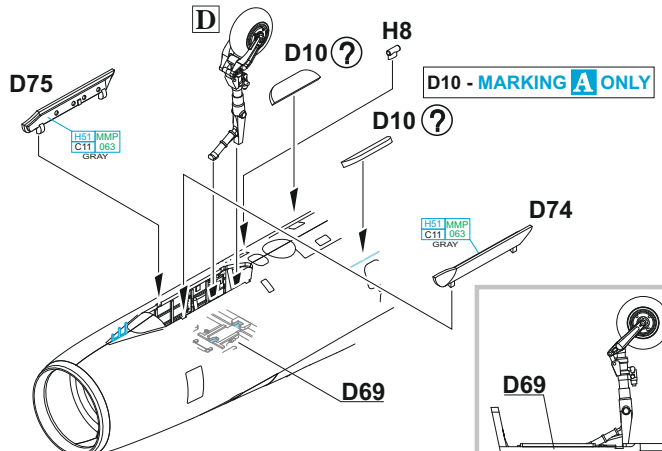
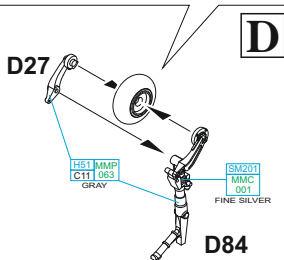
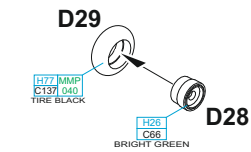
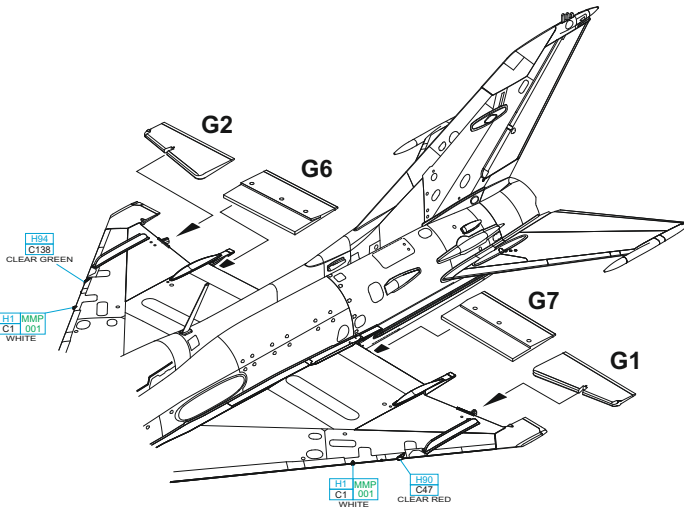
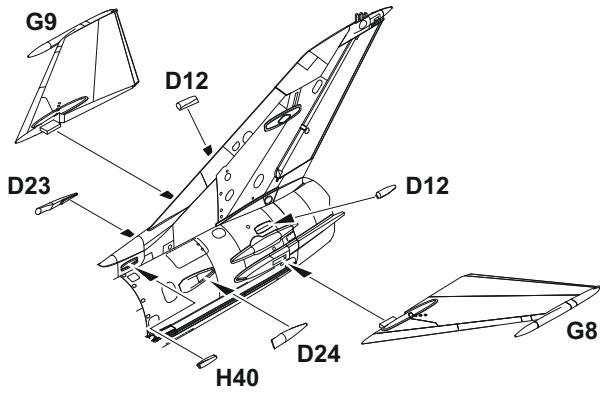

**CLOSED**  
air brake H15



**DEPLOYED**  
air brake H18

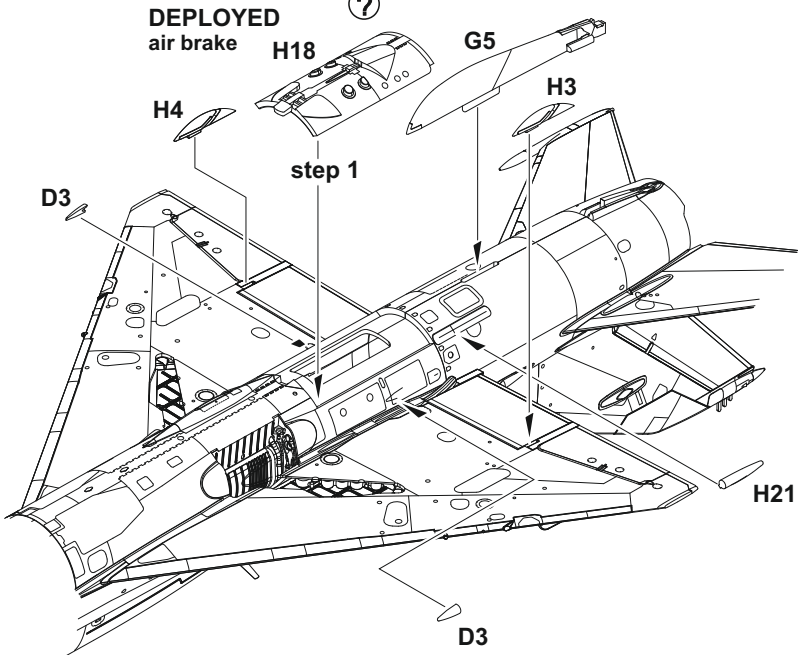
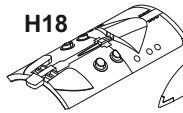

28°

D79  
D78

**L**

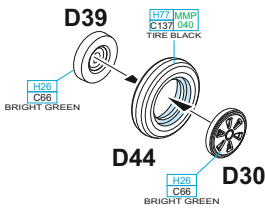
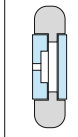

**R**

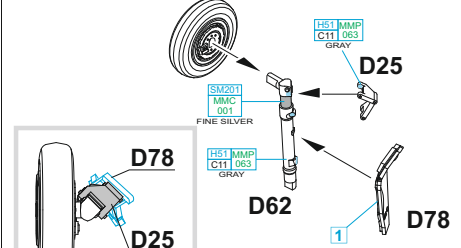
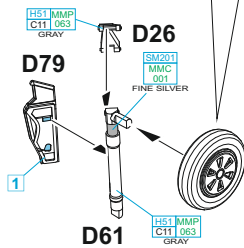
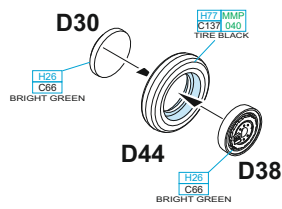
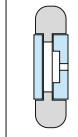

**L**

**R**

SM201  
MMC  
001  
FINE SILVER

SM201  
MMC  
001  
FINE SILVER

H51 MMP  
C11 063  
GRAY

H51 MMP  
C11 063  
GRAY

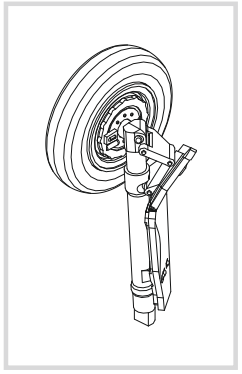

**D16**

**D16**

**G17**

**G16**

**D59**  
**D73**  
**D60**  
**D73**

**D73**  
SM201  
MMC  
001  
FINE SILVER  
H51 MMP  
C11 063  
GRAY

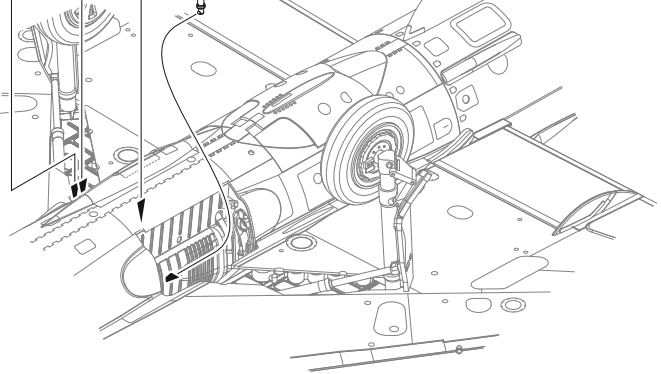
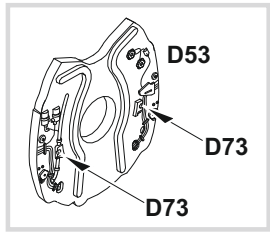

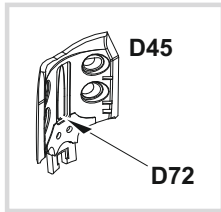

**DEPLOYED** air brake  
**D45**

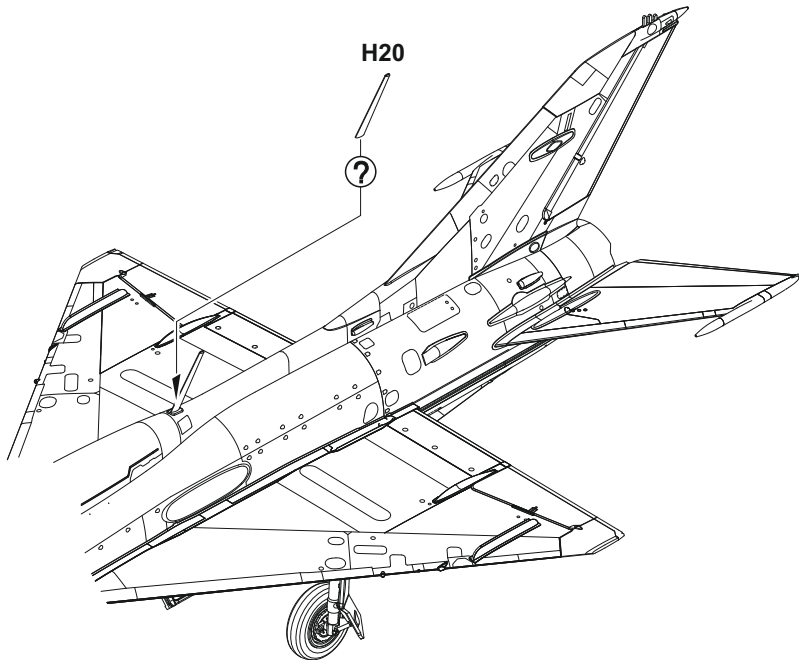
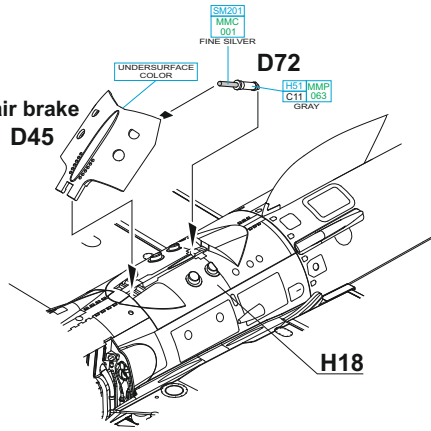

**E**

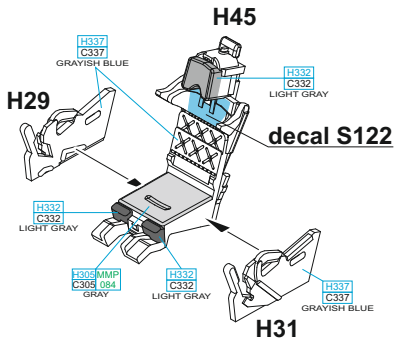

**decal S123**

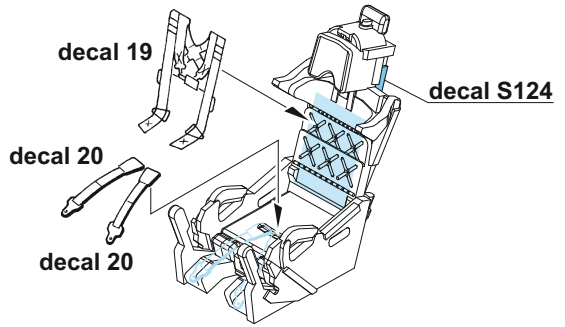

**E**

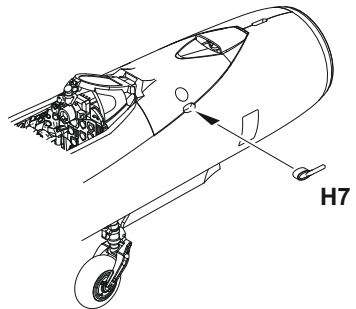
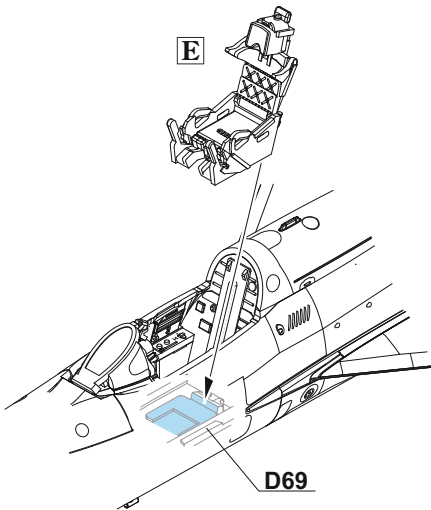

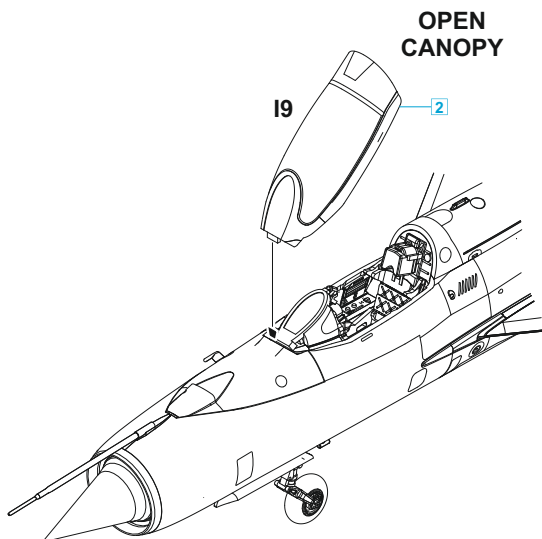
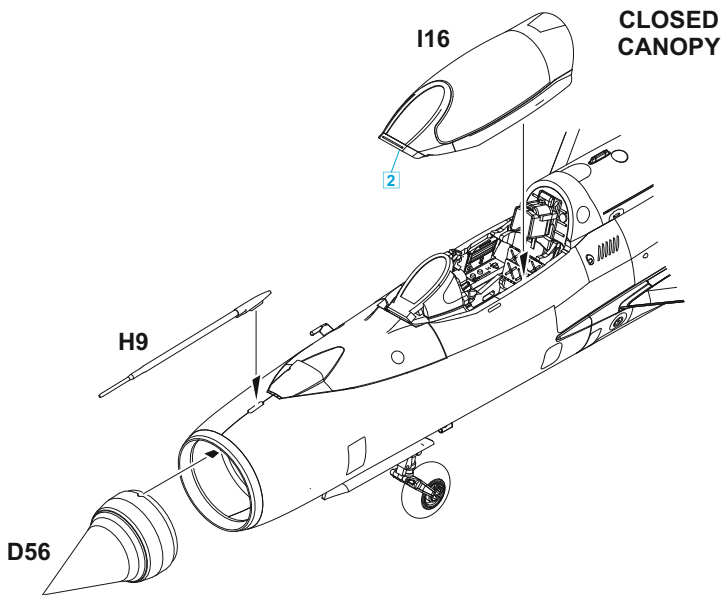

**EXTERNAL FUEL TANK 490 I**  
**PRÍDAVNÁ NÁDRŽ 490 I**

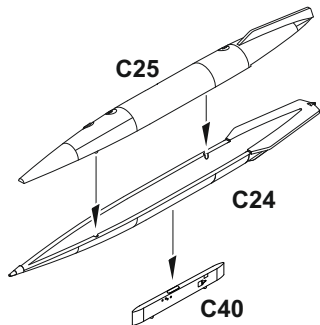

**RS-2US**  
**2 pcs.**

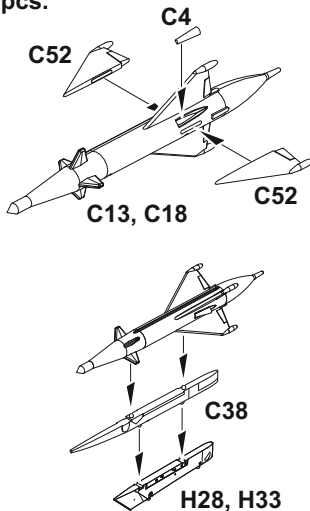

**R-3S**  
**2 pcs.**

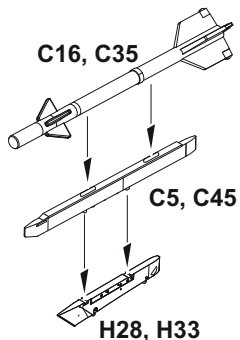

**UB-16**  
**2 pcs.**

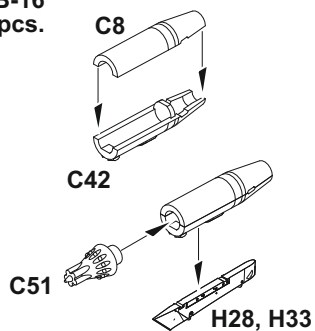

**FAB 250**  
**2 pcs.**

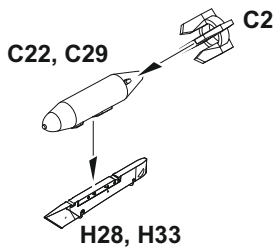

**S-24**  
**2 pcs.**

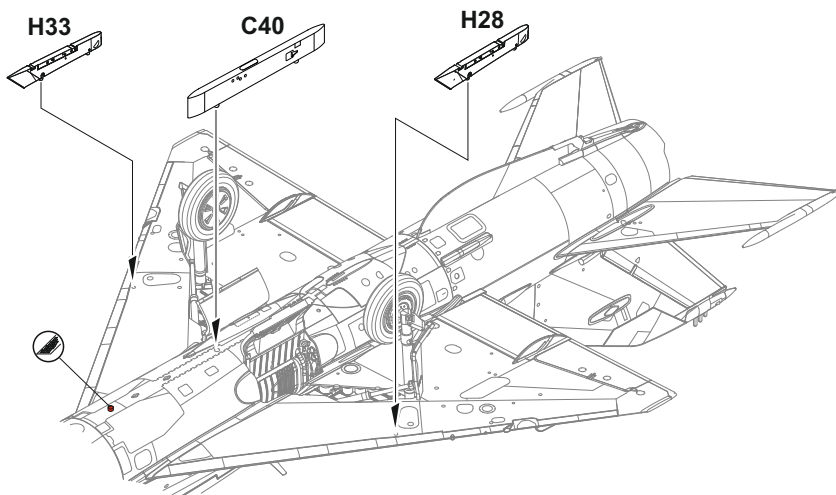
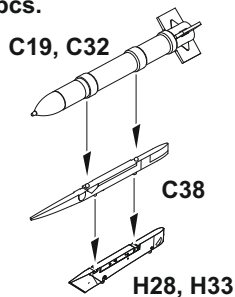

**TO CHOOSE WEAPON AND EXTERNAL FUEL TANK  
OPTION PLEASE FOLLOW YOUR REFERENCE.**

**PRO VOLBU VÝZBROJE A PŘÍDAVNÝCH NÁDRŽÍ SE DRŽTE  
DOKUMENTACE KONKRÉTNÍHO STROJE.**

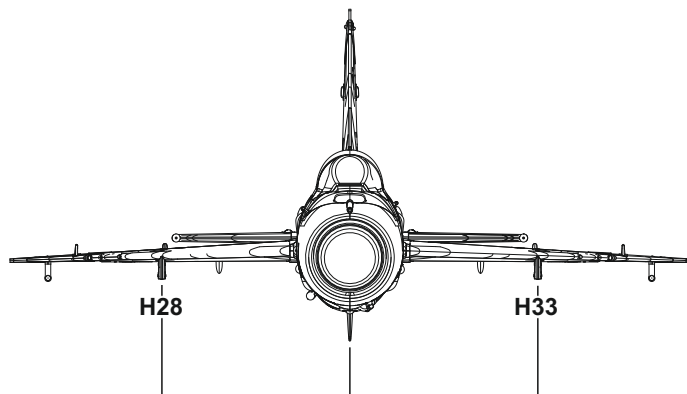

**EXTERNAL  
FUEL  
TANK 490 I**

**C40**



**2x RS-2US**

**C38**



**C38**



**2x R-3S**

**C5**



**C45**



**2x S-24**

**C38**



**C38**



**2x FAB 250**



**2x UB-16**



# A Kacha Higher Military Aviation School of Pilots, Kotelnikovo air base, Soviet Union, 1979

The history of this school goes back to 1910, when a Flight Officer Academy was established at Sevastopol. It continued to function after the socialist revolution, and in 1925 acquired the name of an Armenian Bolshevik revolutionary, Alexander Fyodorovich Myasnikov (also known by the Armenian Myasnikian), who died tragically in March 1925, in a crash of a Junkers F.13. During the course of the Second World War, the school was moved to the Saratov Region to avoid the approaching front, and in 1954, it moved to Stalingrad (known as Volgograd from 1961). It was disbanded in 1998. This MiG-21, used by the Kachinsky Pilot School, was camouflaged in 1979 in two shades of green and two shades of brown on the upper surfaces, while the lower surfaces were in a light blue. Going from black and white photographs, it can not be determined whether the fuselage codes were blue or yellow.

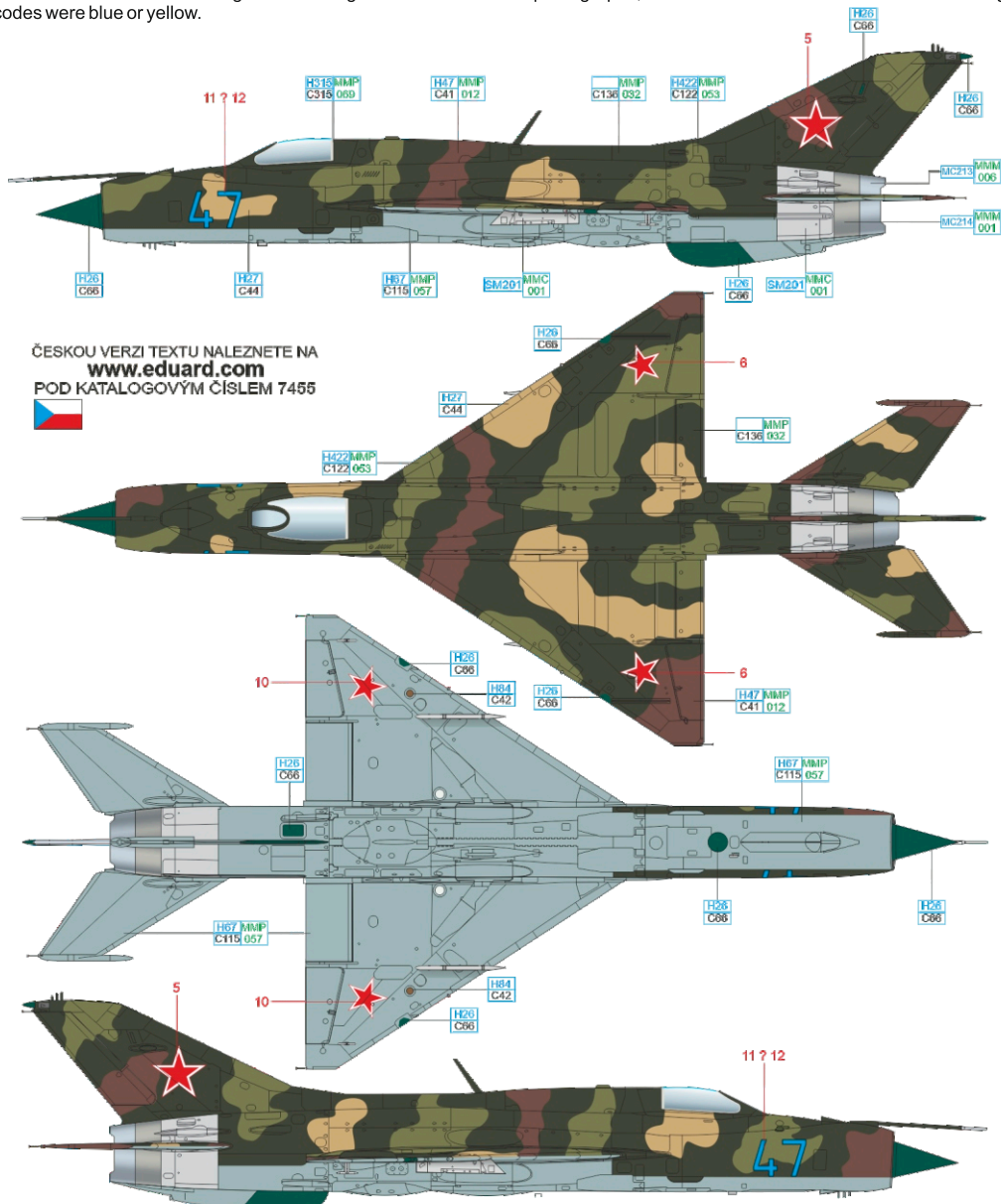

ČESKOU VERZÍ TEXTU NALEZNETE NA  
**www.eduard.com**  
 POD KATALOGOVÝM ČÍSLEM 7455



RED BROWN	H47 MMP C41 012	LIGHT GREEN	H422 MMP C122 053	GREEN	H315 MMP C315 069	TAN	H27 C44
SUPER FINE SILVER	SM201 MMC 001	STEEL	H2913 MMN 006	DARK IRON	H2924 MMN 001	BRIGHT GREEN	H26 C66
						MAHOGANY	H84 C42
						GRAY	H315 MMP C315 069
						BLUE	H167 MMP C115 057



## FUSELAGE PYLON PODTRUPOVÝ PYLON

C40

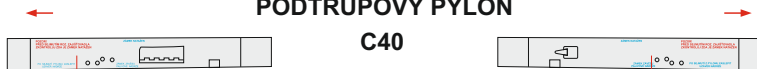

S160

EXTERNAL FUEL TANK 800 l  
PŘÍDAVNÁ NÁDRŽ TANK 800 l

S161

## LEFT PYLON LEVÝ PYLON

S132

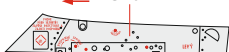

UB-16, FAB 250

## RIGHT PYLON PRAVÝ PYLON

S133

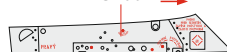

S134



S135

## LEFT APU-7 LEVÉ APU-7

C38

RS-24S, S-24



S128

SM201  
MMC  
001

## RIGHT APU-7 PRAVÉ APU-7

S129



## LEFT APU-13 LEVÉ APU-13

C5, C45

R-3S



S126

SM201  
MMC  
001

## RIGHT APU-13 PRAVÉ APU-13

S127



## EXTERNAL FUEL TANK 800 l PŘÍDAVNÁ NÁDRŽ TANK 800 l

TOP



S150

S150

## UB-16

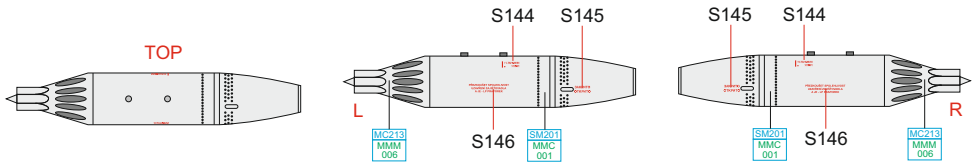

## R-3S

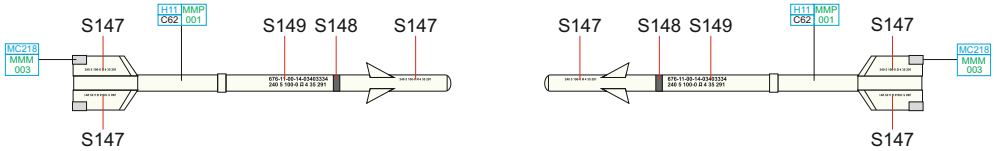

## S-24

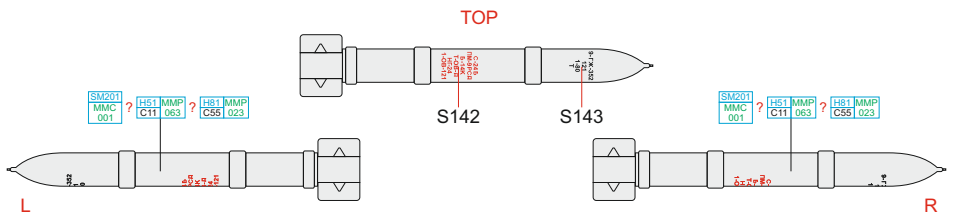

## RS-2US

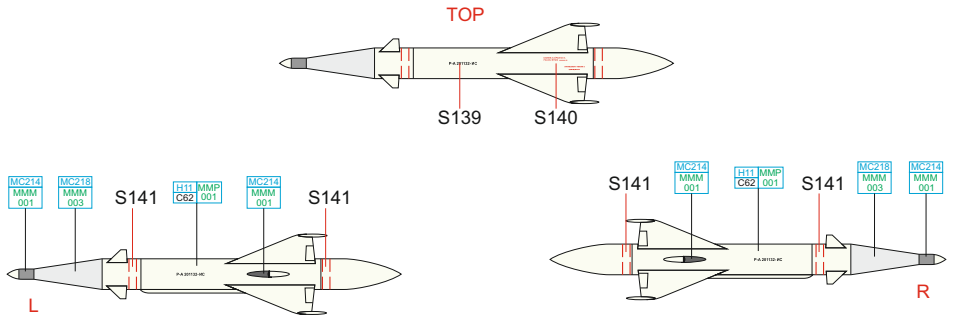

## FAB 250

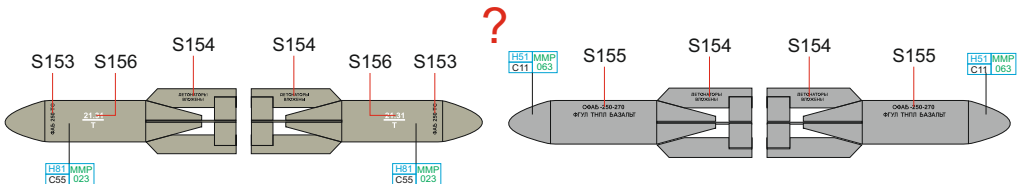

S1 - S161 - MARKING **B**

S1 - S161 - MARKING **A**

S1 - S161 - FOR UPPER SURFACES  
ON MARKING **A**

