

Bf 109F-2

eduard

1/72 Scale Plastic Model Kit

WEEKEND
edition



item # 7474

No other aircraft is as intimately connected with the rise and fall of the German Luftwaffe in the course of the WWII as the Messerschmitt Bf 109. A very progressive design at the time of its invention, it had plenty of room for further development.

The history of the Bf 109 begins with the requirement L.A. 1432/33 issued by Reich Ministry of Aviation (RLM) in late March 1933. It called for the development of a single-engined monoplane fighter. Proposals were submitted by Arado, Heinkel, Focke-Wulf and Bayerische Flugzeugwerke. The design bureau of the last-mentioned company was led by its technical director Willy Messerschmitt, who was riding a wave of popularity based on the success of his liaison aircraft, the Bf 108. Messerschmitt's goal was to create an aircraft with the best possible performance for the specified weight and size. Over the following months, several prototypes were built that served first and foremost in development flights and further modifications. The aircraft was relatively small, and compared to the prevailing trends of the time, sported several quite revolutionary features such as low wing design, retractable landing gear, wing with a thin airfoil, wing slats, landing flaps, weapons firing through the propeller hub, and so on. Even the enclosed cockpit and [the method of] (not needed) the airframe structure design were not usual just four years prior to the beginning of the Second World War. At its conception, the Bf 109 was a very promising asset despite some powerplant troubles. These were solved by the introduction of the DB 601. This engine, together with its extrapolated development DB 605, is umbilically connected to the success of the Bf 109.

From Spanish War to the Reich Defence

The first combat use of Bf 109 occurred during Spanish Civil War, where three developmental Bf 109s were deployed in December 1936. The main reason of revealing the modern fighter to the world was quite down-to-earth: To validate its abilities in modern aerial combat. Shortly thereafter, production aircraft in the form of the Bf 109B-1 began to reach 2.J/88, the Legion Condor. The desire of Germany to demonstrate its aerial prowess to potential foes was advanced further in international sport meets. The triumph attained in Zurich in the summer of 1937 was complemented several months later by grabbing the speed record of 379.63 mph (610.95 km/h). In very short order, the progressive developments represented by the C, D and E versions appeared.

Despite this, the delivery of the aircraft to combat units did not sustain the rate desired by military brass. Even by August 1938 the Bf 109 accounted for less than half of the 643 front line fighters in service. The next months saw an increase in these rates. By the time of the invasion of Poland (which saw the participation of only a little more than 200 aircraft) the Luftwaffe possessed the best fighter produced in continental Europe. So the fighter wing of the Luftwaffe entered the Polish campaign, the Blitzkrieg against the West, and the Battle for France with both a qualitative and quantitative advantage. With one foot in the door that was

the English Channel, the Luftwaffe embarked on the attacks on Britain in the summer months of 1940. Here, the first weakness of the Bf 109 emerged: The inability to carry drop tanks that would have enabled the type to effectively escort bombers to England. Experience gained in 1940 led to the development of the F version prior to the spring of 1941. The elegance of the Bf 109 crested with the "Friedrich". Following a largely defensive stance over the Channel and northern France, the Bf 109F took on a more offensive role in Operation Barbarossa in the east, and in northern Africa. In later duties with the "Jagdwaaffe" during the second phase of the war in the east, and in the "Defence of the Reich" from 1943 to 1945, the Bf 109s served in the form of the G version, followed by the K. Even if it was clear that the development of the Bf 109 had reached its limits by the end of the war, the aircraft was still able to keep pace with the foes that it encountered. Besides its primary purpose as a fighter, the Bf 109 also appeared as a fighter-bomber, reconnaissance platform, night fighter, trainer and rammjäger.

Postwar service

The disappearance of the Bf 109 from the skies over Europe was not spelled out by the end of the war. Several examples stayed in Swiss service up to 1949 and many flew in the air force of Czechoslovakia in both original form with a DB 605 powerplant and as an aircraft built out of necessity with surplus Jumo 211s. The latter type also served as the first fighter to fight for the independence of the newly formed state of Israel. Finland retired the type as recently as 1954, and Spain did not retire their HA-1109-1112, re-engined Bf 109s, until 1967.

The kit: Bf 109F-2

The Bf 109F series (Friedrich) was a major improvement of the Bf 109E. There were numerous aerodynamical changes, giving the Bf 109 the shape, which was close to the "definitive" appearance. The engine cowling was completely redesigned and was more rounded and streamlined. The spinner was larger, and its shape transitioned smoothly into the line of the front fuselage.

The oil cooler radiator below the nose was also streamlined. The wing lost its typical rectangle shape as a new rounded wingtips were developed. The armament was also revised and consisted of two .312 in (7.92 mm) MG 17 machine guns mounted on top of the engine and one 15 mm MG 151 cannon firing through the propeller spindle. The new aircraft was well received as it was the best handling Bf 109 of them all according to many pilots. The F-2 version was using VDM 9-11207 propeller driven by the DB 601N engine. The first Bf 109F-2s arrived in October 1940 and the production ran until August 1941. During that period some 1,230 of the Bf 109F-2 were produced.

ATTENTION



UPOZORNĚNÍ



ACHTUNG



ATTENTION



注意



Carefully read instruction sheet before assembling. When you use glue or paint, do not use near open flame and use in well ventilated room. Keep out of reach of small children. Children must not be allowed to suck any part, or pull vinyl bag over the head.



Před započítím stavby si pečlivě prostudujte stavební návod. Při používání barev a lepidel pracujte v dobře větrané místnosti. Lepidla ani barvy nepoužívejte v blízkosti otevřeného ohně. Model není určen malým dětem, mohlo by dojít k požití drobných dílů.

INSTRUCTION SIGNS



INSTR. SYMBOLS



INSTRUKTION SINNBILDEN



SYMBOLES



記号の説明

OPTIONAL
VOLBABEND
OHNOUTSAND
BROUSITOPEN HOLE
VYVRTAT OTVORSYMETRICAL ASSEMBLY
SYMETRICKÁ MONTÁŽREMOVE
ODRÍZNOUTREVERSE SIDE
OTOČITAPPLY EDUARD MASK
AND PAINT
POUŽIT EDUARD MASK
NABARVIT

PLEASE, CHECK THE LATEST VERSION OF THE INSTRUCTIONS ON www.eduard.com

PARTS



DÍLY



TEILE



PIÈCES



部品

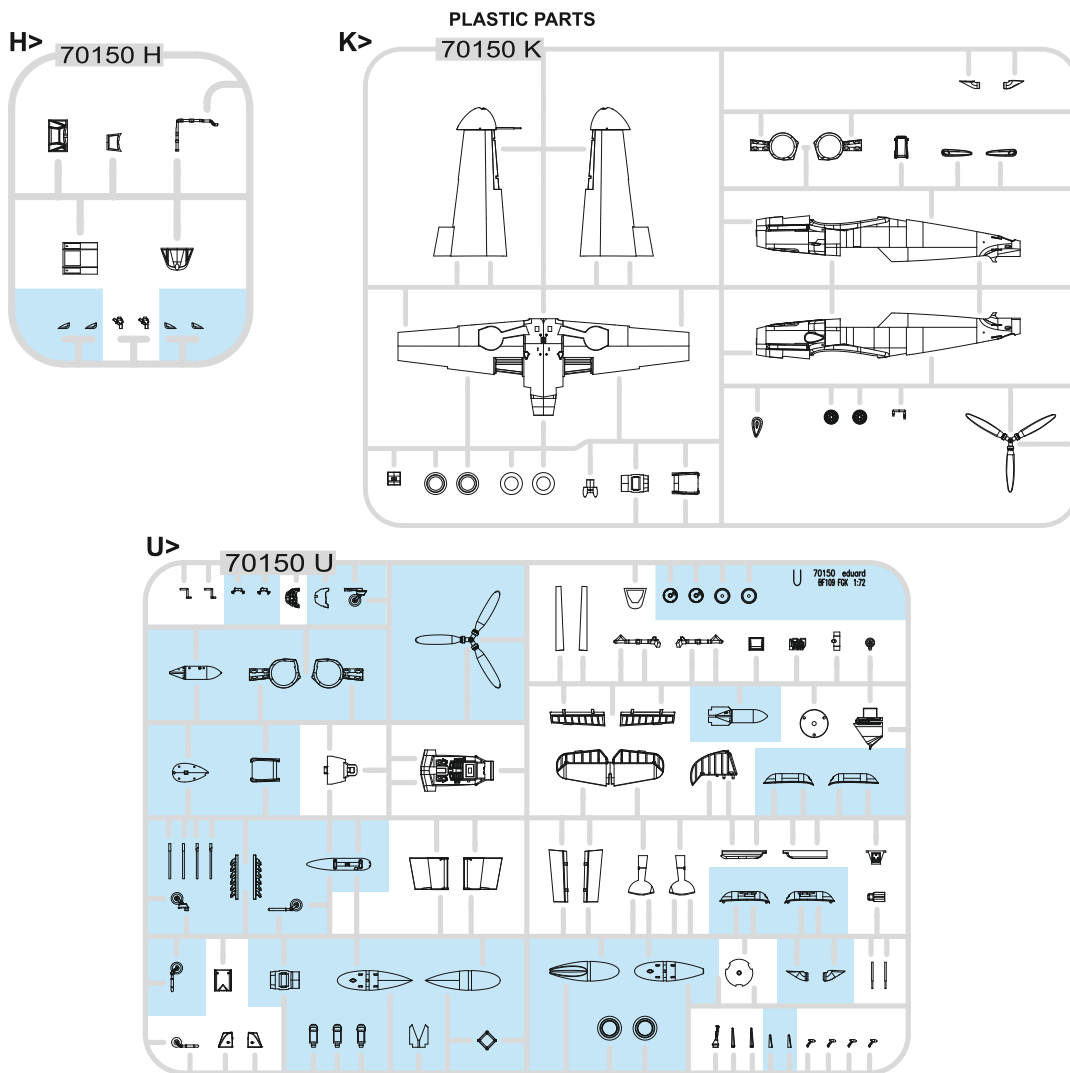

-Parts not for use. -Teile werden nicht verwendet. -Pièces à ne pas utiliser. -Tyto díly nepoužívejte při stavbě. - 使用しない部品

COLOURS



BARVY



FARBEN



PEINTURE



色

GSI Creos (GUNZE)		
AQUEOUS	Mr.COLOR	
H2	C2	BLACK
H11	C62	FLAT WHITE
H12	C33	FLAT BLACK
H47	C41	RED BROWN
H64	C17	RLM71 DARK GREEN
H65	C18	RLM70 BLACK GREEN
H68	C36	RLM74 DARK GRAY
H69	C37	RLM75 GRAY
H70	C60	RLM02 GRAY
H77	C137	TIRE BLACK
H90	C47	CLEAR RED
H94	C138	CLEAR GREEN

GSI Creos (GUNZE)		
AQUEOUS	Mr.COLOR	
H413	C113	RLM04 YELLOW
H414	C114	RLM23 RED
H416	C116	RLM66 BLACK GRAY
H417	C117	RLM76 LIGHT BLUE
Mr.METAL COLOR		
MC214		DARK IRON
MC219		BRASS
Mr.COLOR SUPER METALLIC		
SM201		SUPER FINE SILVER
Mr.COLOR GX		
GX05		SUSIE BLUE

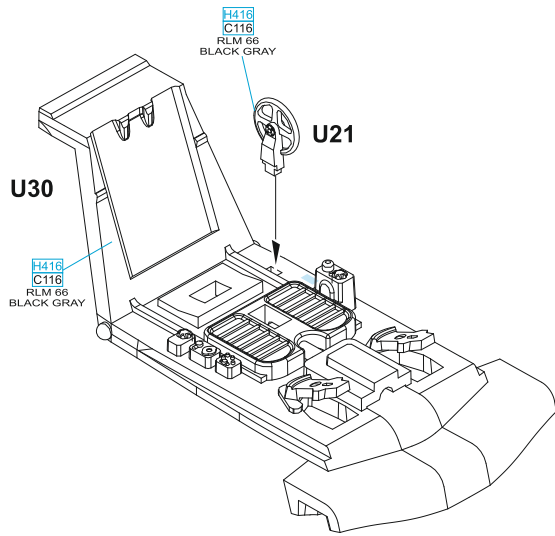

U55 - IF YOU USE IN THE NEXT STEP PART U18 ONLY

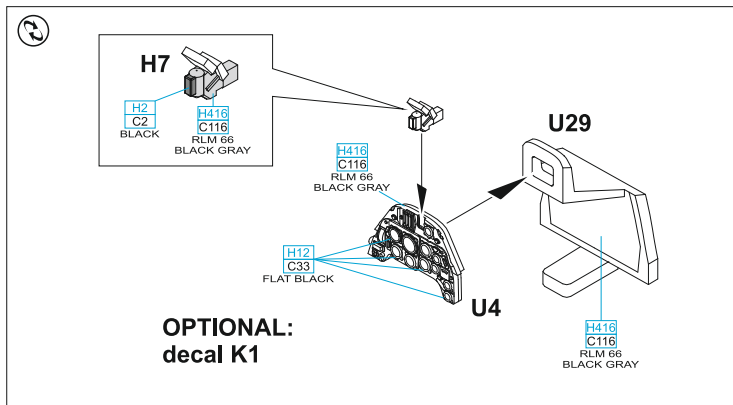
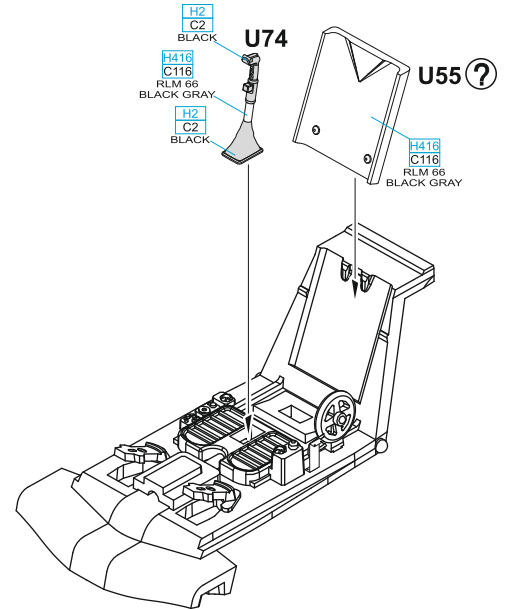

SEAT K8 + K13 USED RARELY

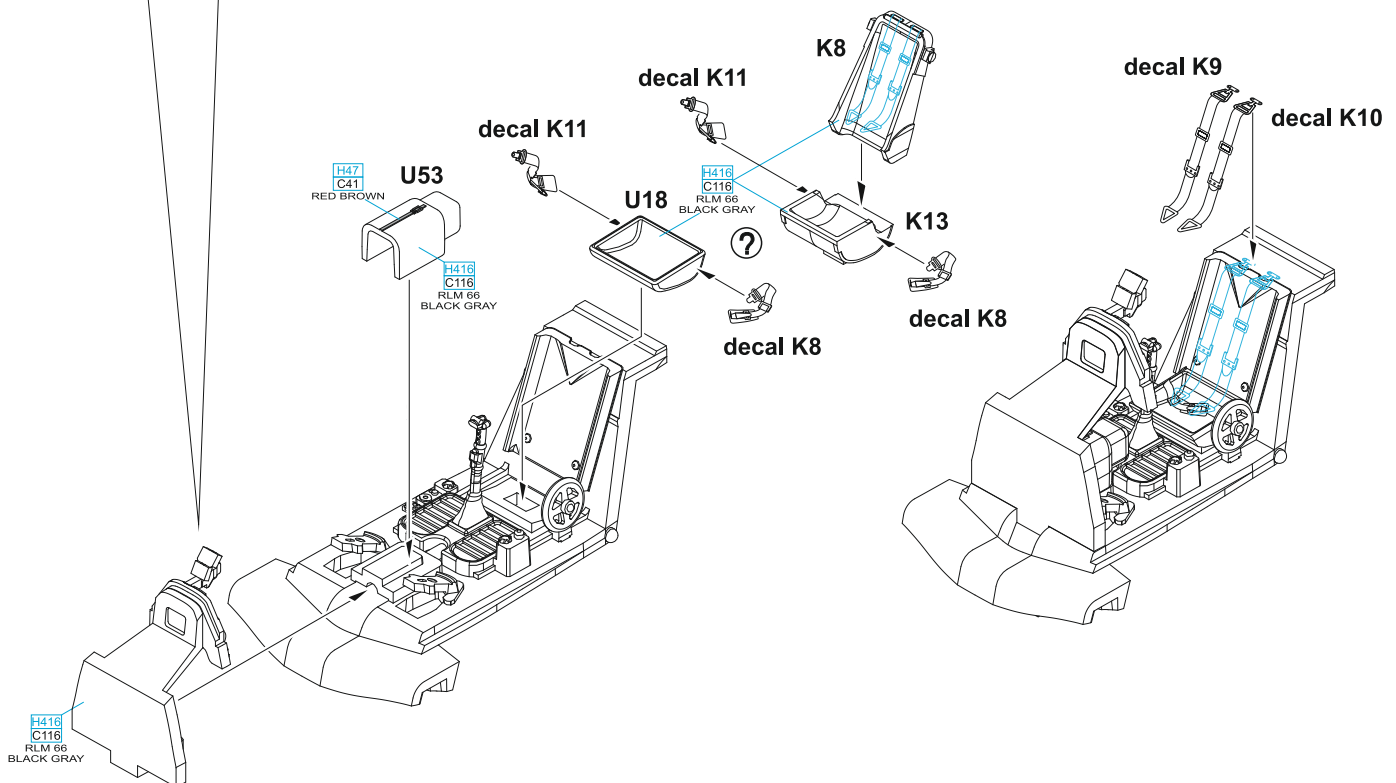

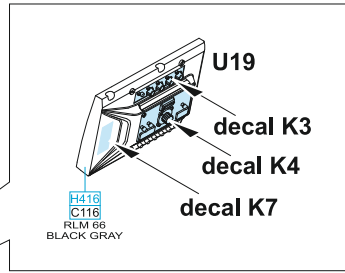
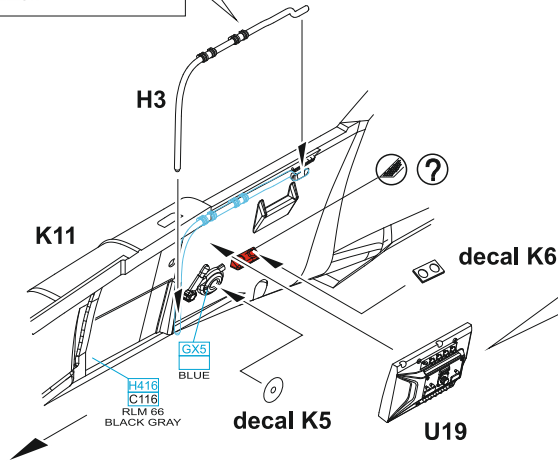
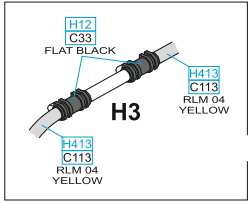

K9 port side

 K10 starboard

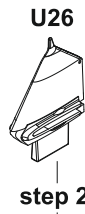
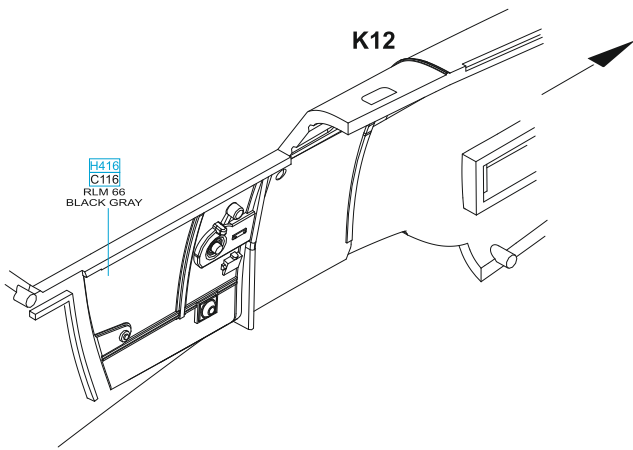
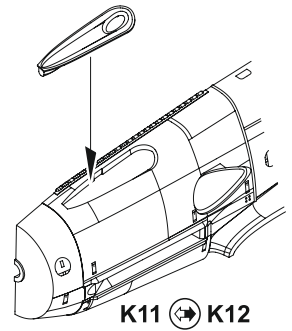

step 2

step 1

step 3



H70
C80
RLM 02
GRAY

U67

U66

step 3

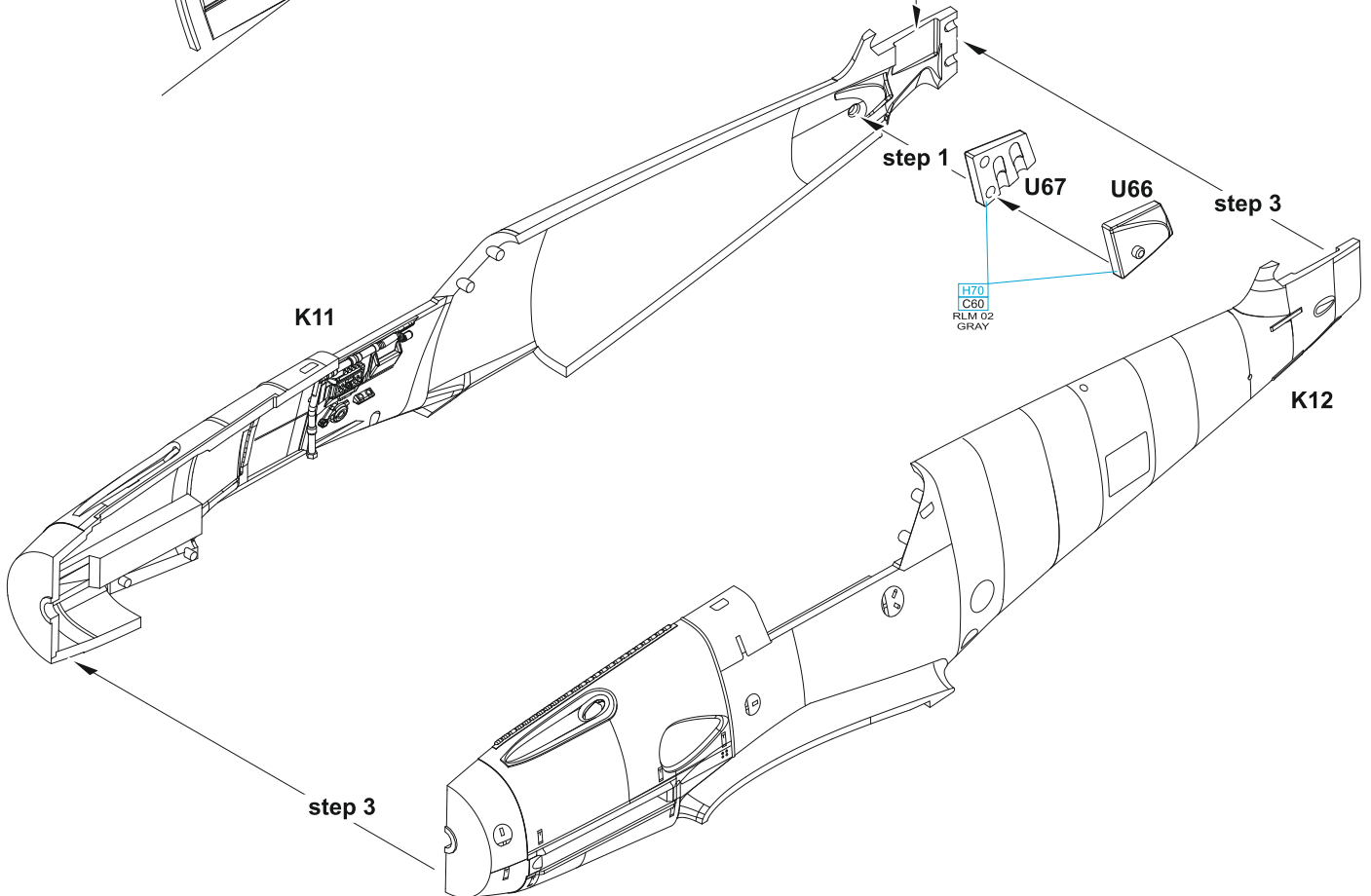

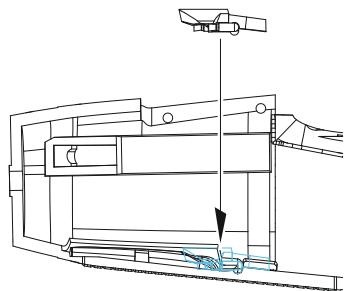
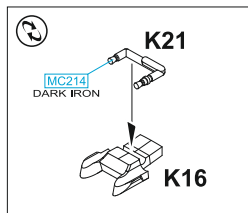

∅ - 0,2 mm

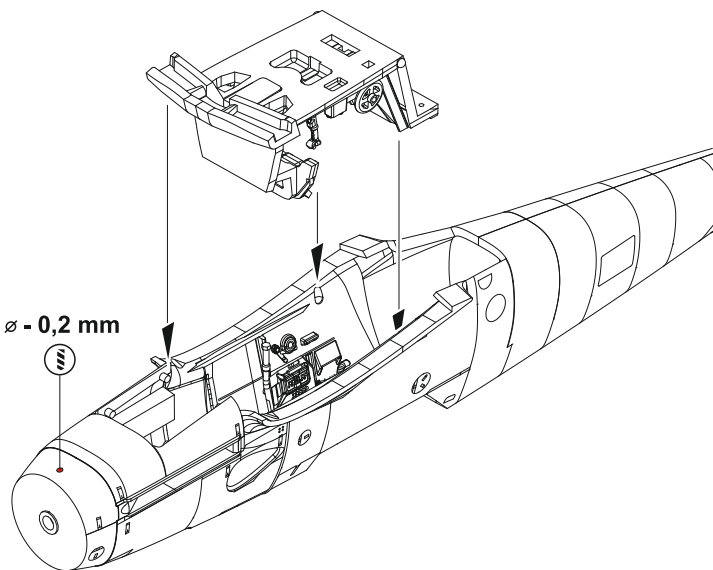

H416
C116
RLM 66
BLACK GRAY

U7

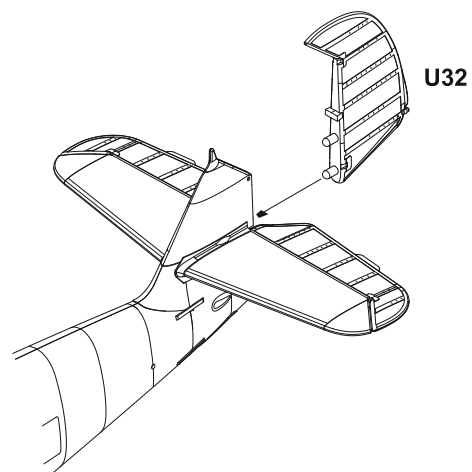
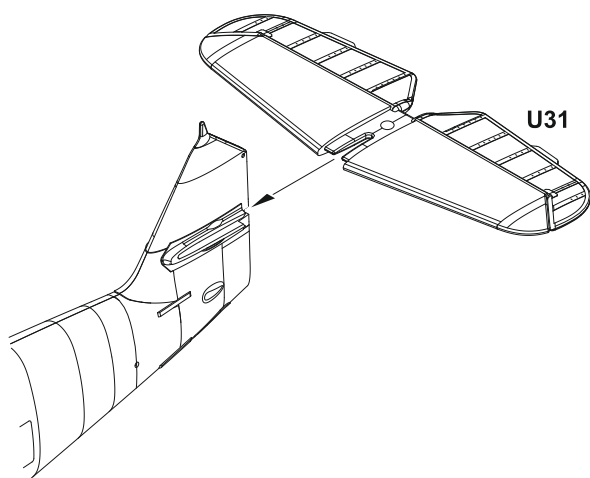
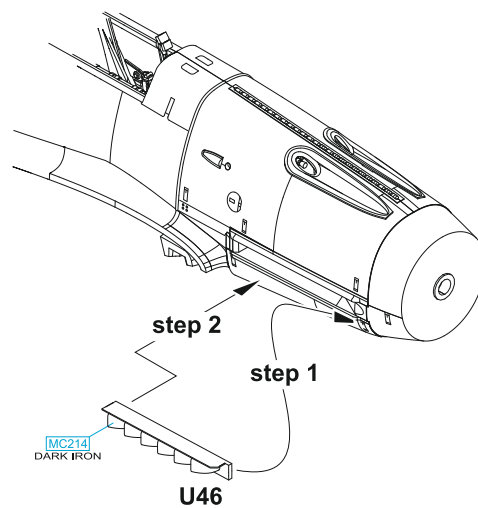
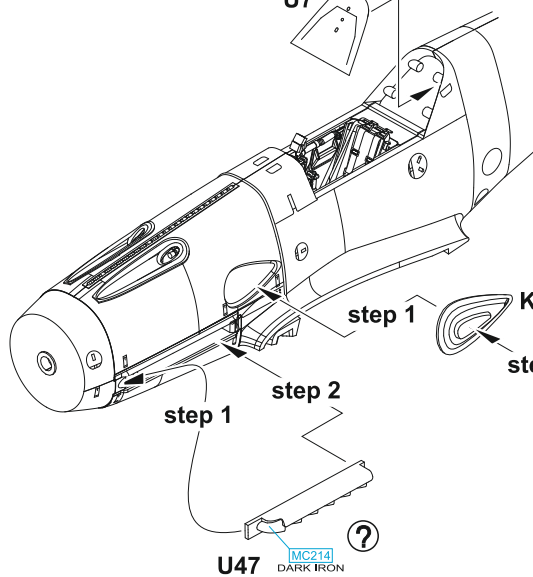

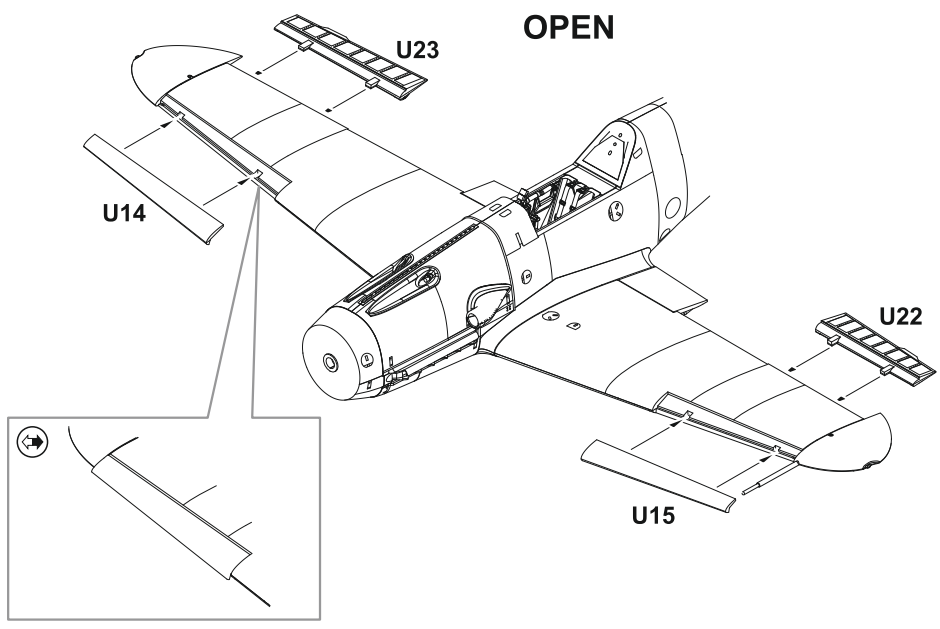
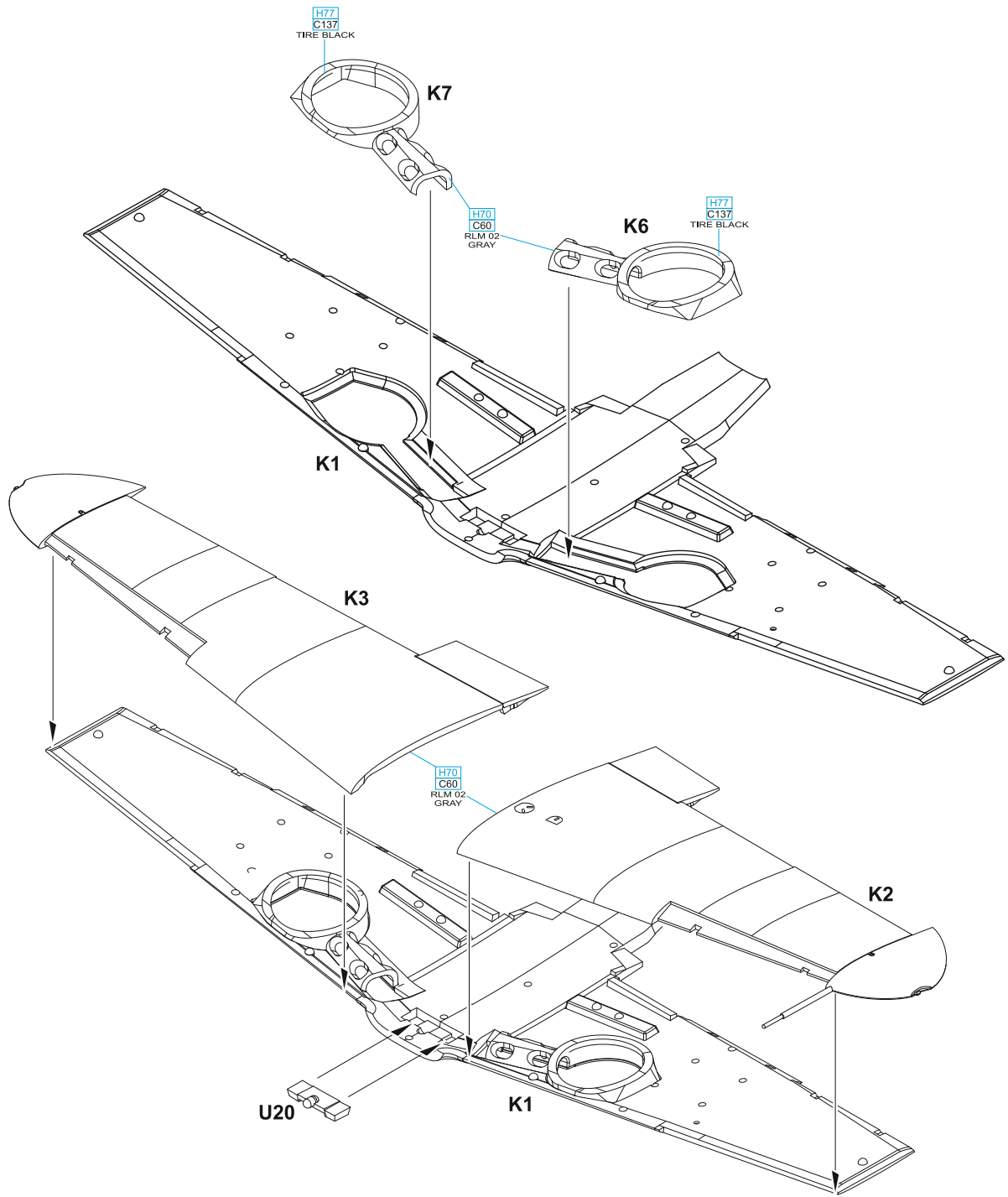

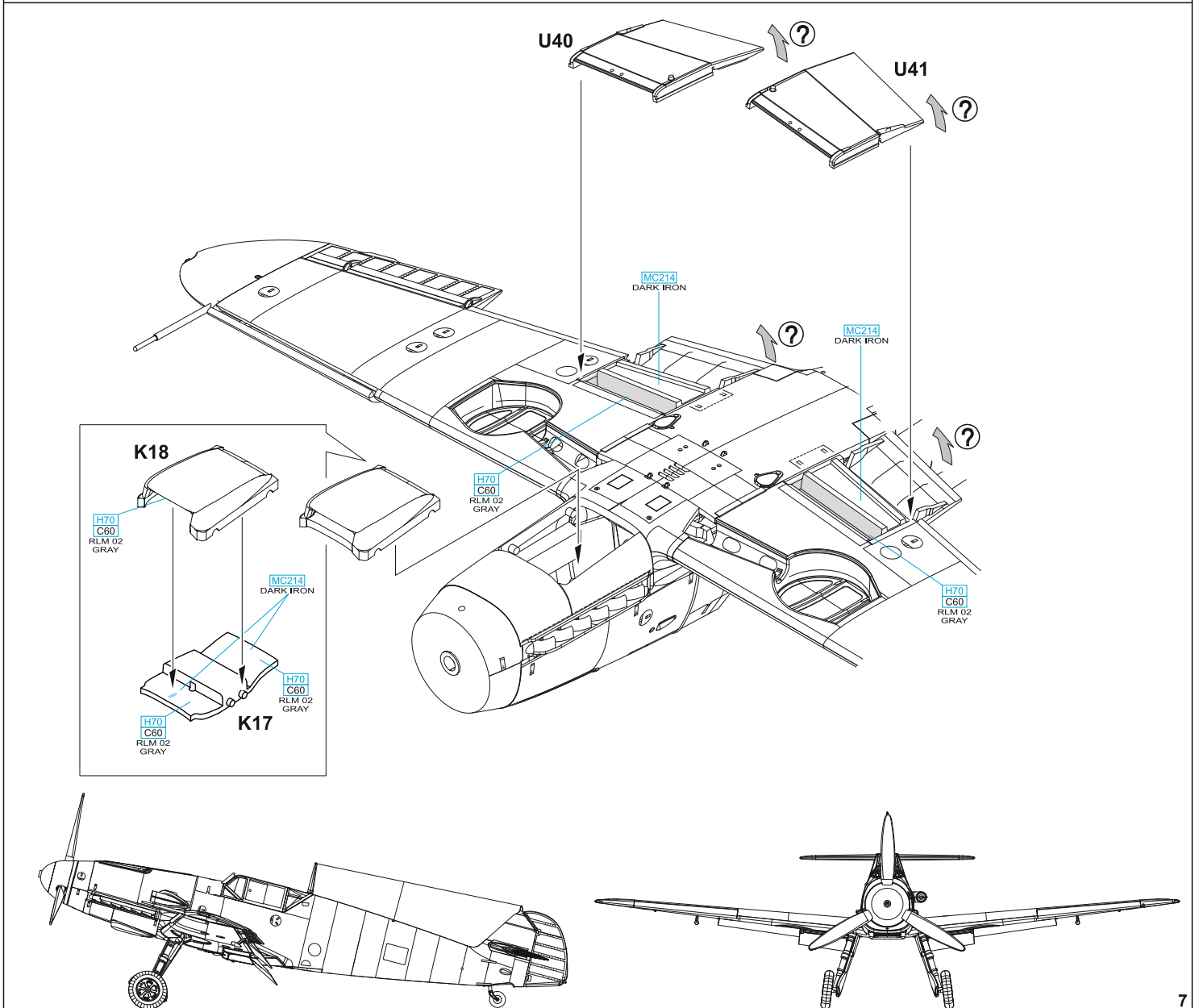
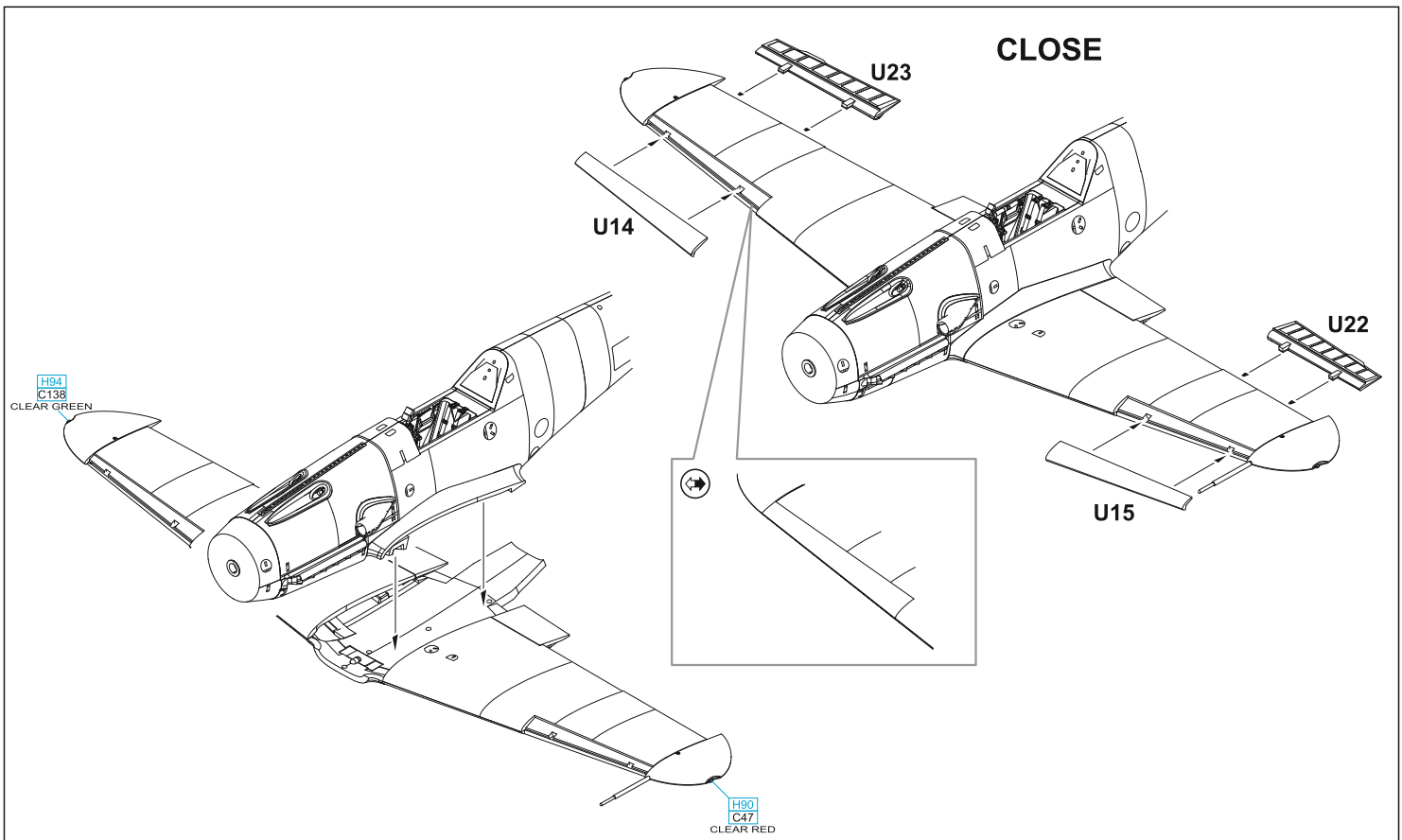

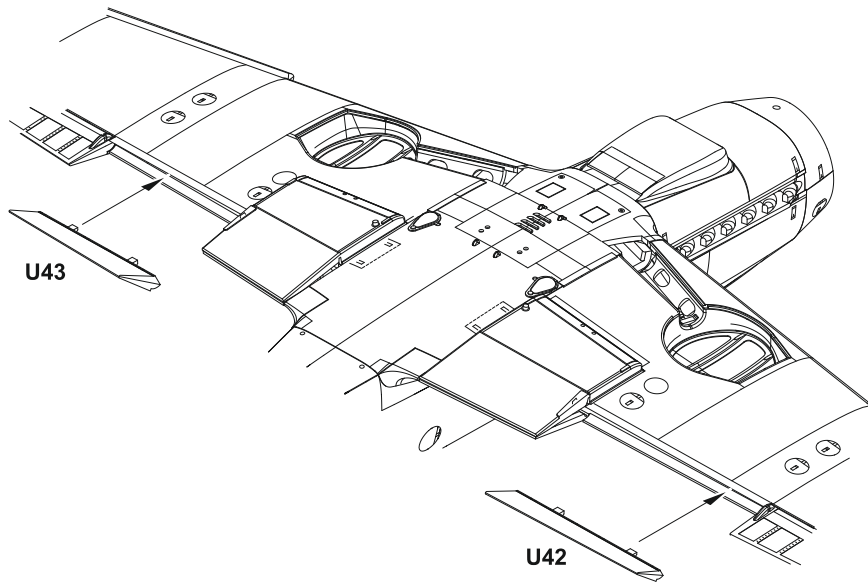

U43

U42

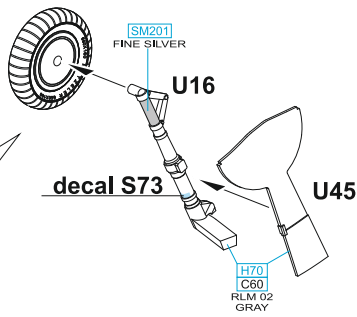
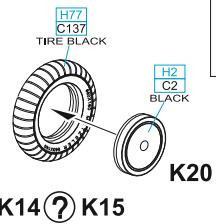
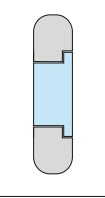

U44

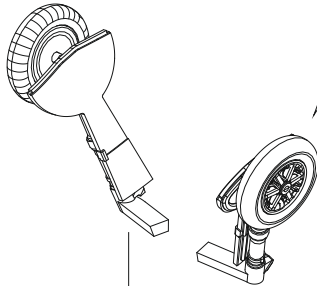
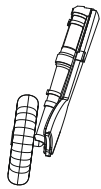
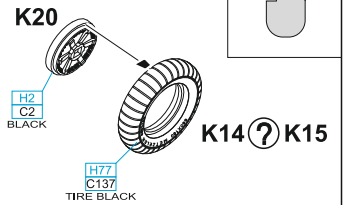
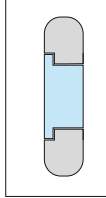
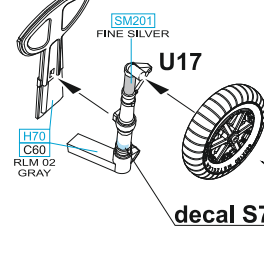

U77

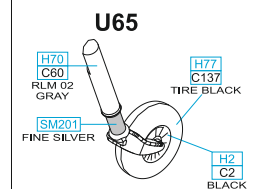

U65

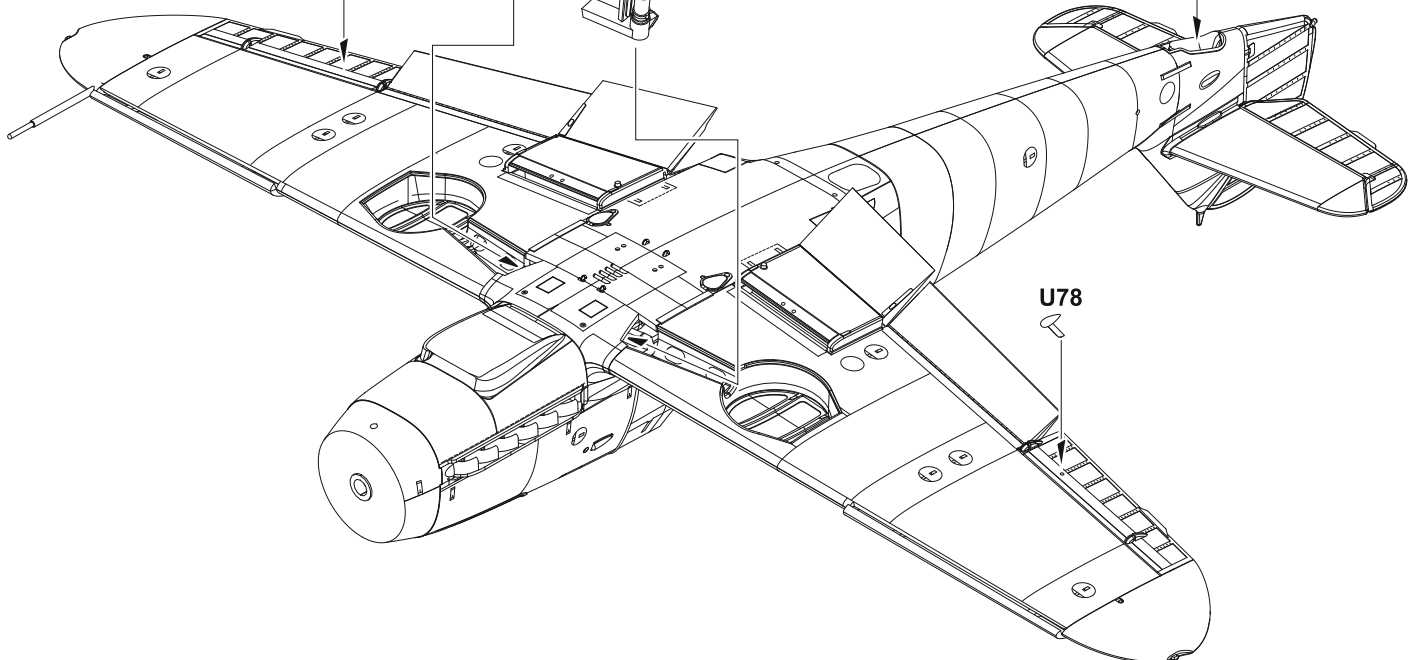
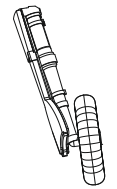

U78

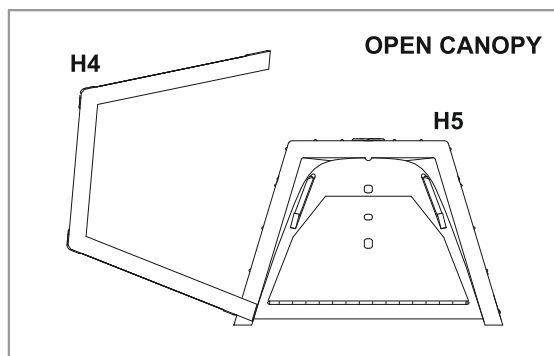
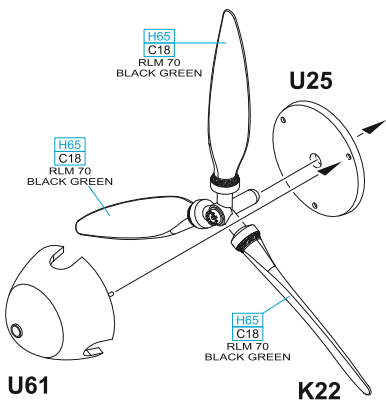
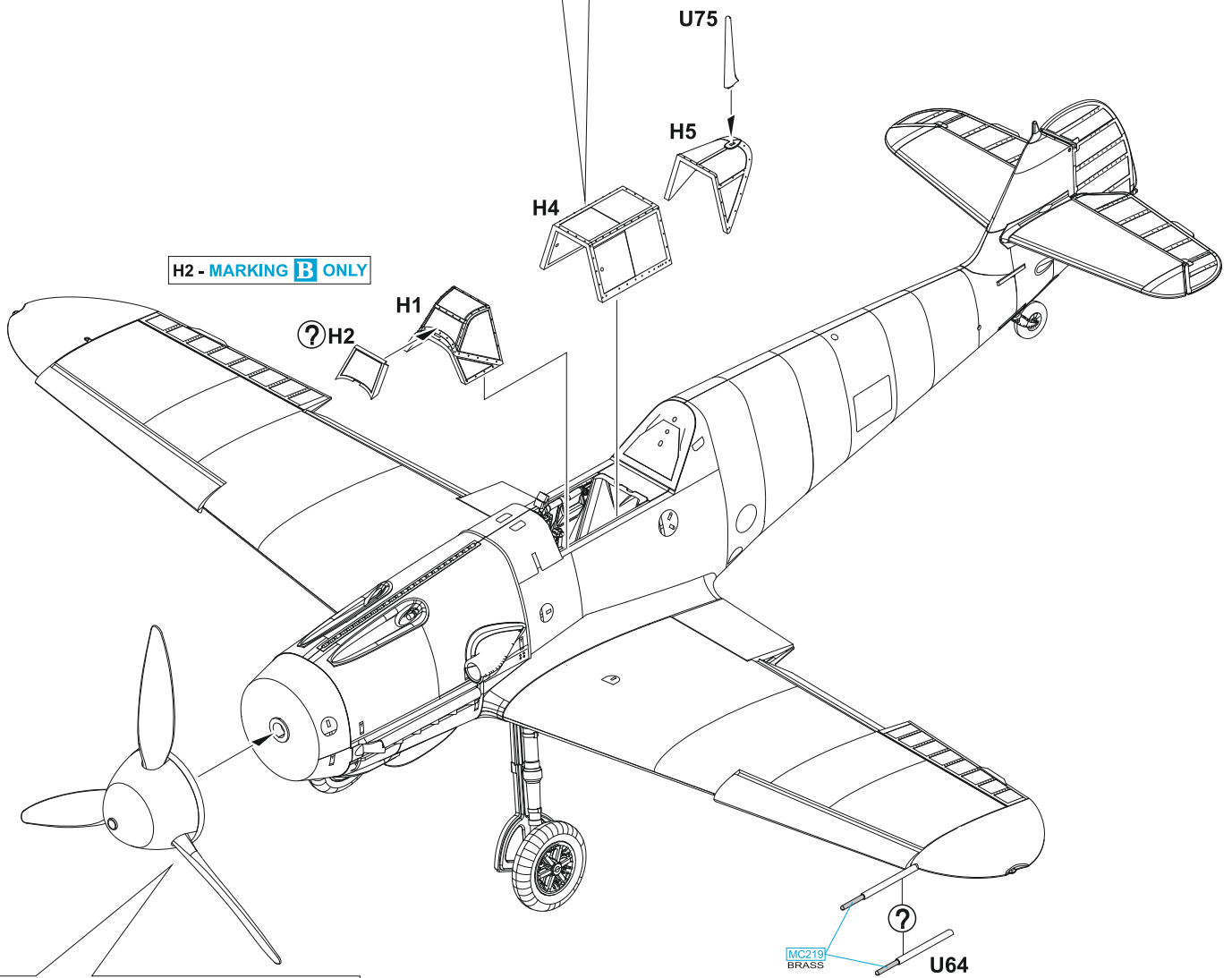
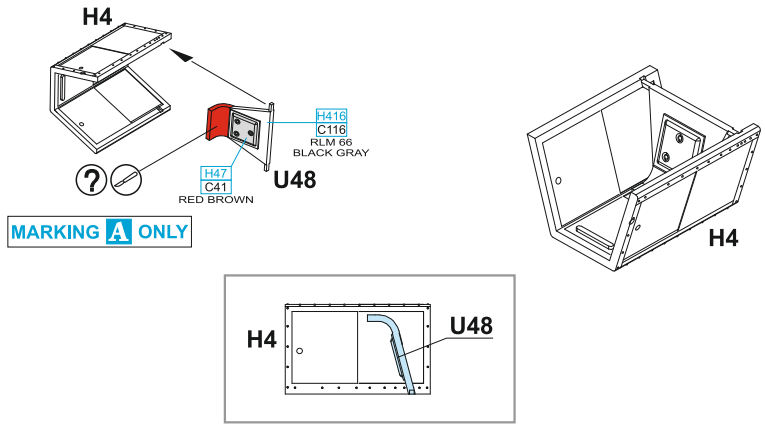
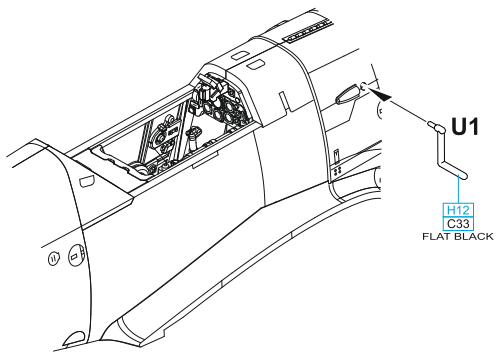

A Hptm. Hans Hahn, CO of III./JG 2, Saint-Pol-sur-Ternoise, France, July 1941

Hans "Assi" Hahn, a fighter ace and recipient of the Knight's Cross with Oak Leaves, led the 4./JG 2 from December 1939 and the III./JG 2 from October 29, 1940. A total of 31 victory symbols on the tail of his aircraft were tied to Hahn's operations on the Western Front. His 31st victory was achieved on July 10, 1941, near Saint-Omer, when he shot down two Spitfires. Beginning on November 1, 1942, he took command of II./JG 54 and led this Gruppe until February 21, 1943, when he was shot down and captured by Soviet forces. Hahn was not released from captivity until 1950, during which he wrote a book about his experiences in prison titled *Ich spreche die Wahrheit!* (I speak the truth!). Before his capture, he achieved 108 victories, 66 of which were on the Western Front. The rooster's head painted on his aircraft symbolized the III. Gruppe JG 2's staff planes and was derived from Hahn's surname, as "Hahn" means rooster in German. Hans Hahn passed away in 1982, and his wife later remarried the night fighter pilot Wolfgang Falck.

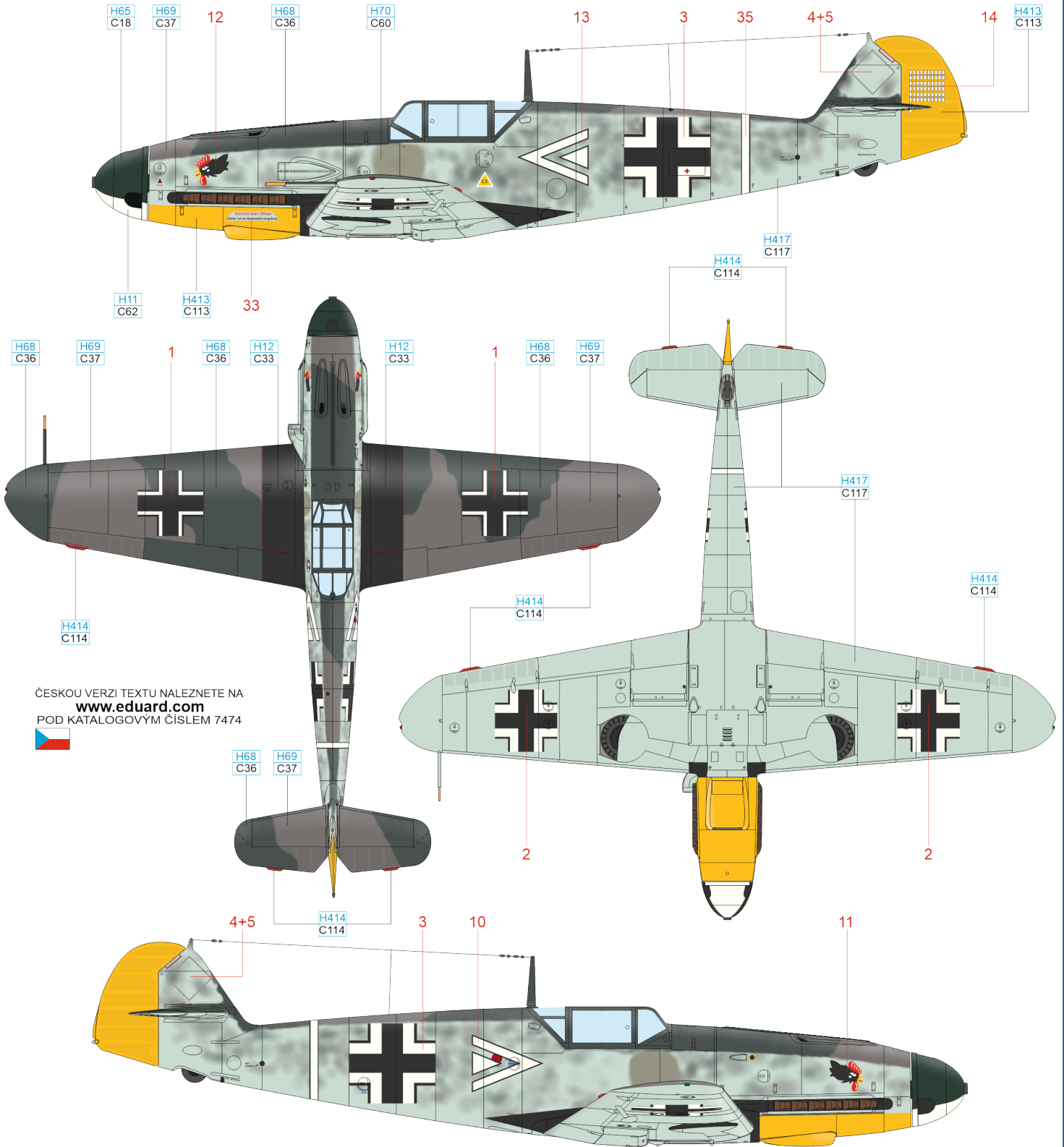

ČESKOU VERZI TEXTU NALEZNETE NA
www.eduard.com
 POD KATALOGOVÝM ČÍSLEM 7474



- | | | | | | | | | | | | | | | | | | |
|------------|---------|--------|-----------|--------|---------|--------|---------|--------|---------|--------|-----------|--------|-----------|--------|---------|------------|---------|
| FLAT WHITE | H11 C62 | RLM 76 | H417 C117 | RLM 75 | H69 C37 | RLM 74 | H68 C36 | RLM 02 | H70 C60 | RLM 04 | H413 C113 | RLM 23 | H414 C114 | RLM 70 | H65 C18 | FLAT BLACK | H12 C33 |
|------------|---------|--------|-----------|--------|---------|--------|---------|--------|---------|--------|-----------|--------|-----------|--------|---------|------------|---------|



B WNr. 8239, Lt. Hans Strelow, 5./JG 51, Bryansk, the Soviet Union, March 1942

Hans Strelow was born on March 26, 1922, in Berlin. In 1939, he voluntarily joined the Luftwaffe. After completing training in February 1941, he was assigned to 5./JG 51. From the start of Operation Barbarossa, he flew on the Eastern Front. He achieved his first aerial victory on June 25, 1941. In January 1942, he was appointed Staffelfeldkapitän of 5./JG 51. On March 24, 1942, he became the youngest recipient of the Knight's Cross with Oak Leaves. His Black 10 was painted with white on the upper surfaces during the winter period. The JG 51 insignia was displayed on both sides of the nose. The yellow band behind the cross and the yellow wingtips were identification markings used on the Eastern Front. The victories he achieved were marked on the left side of the tail. On May 22, 1942, Hans Strelow was shot down by a Pe-2 crew and forced to make an emergency landing behind Soviet lines. Fearing capture by the Red Army, he conducted suicide by shooting himself in his head.

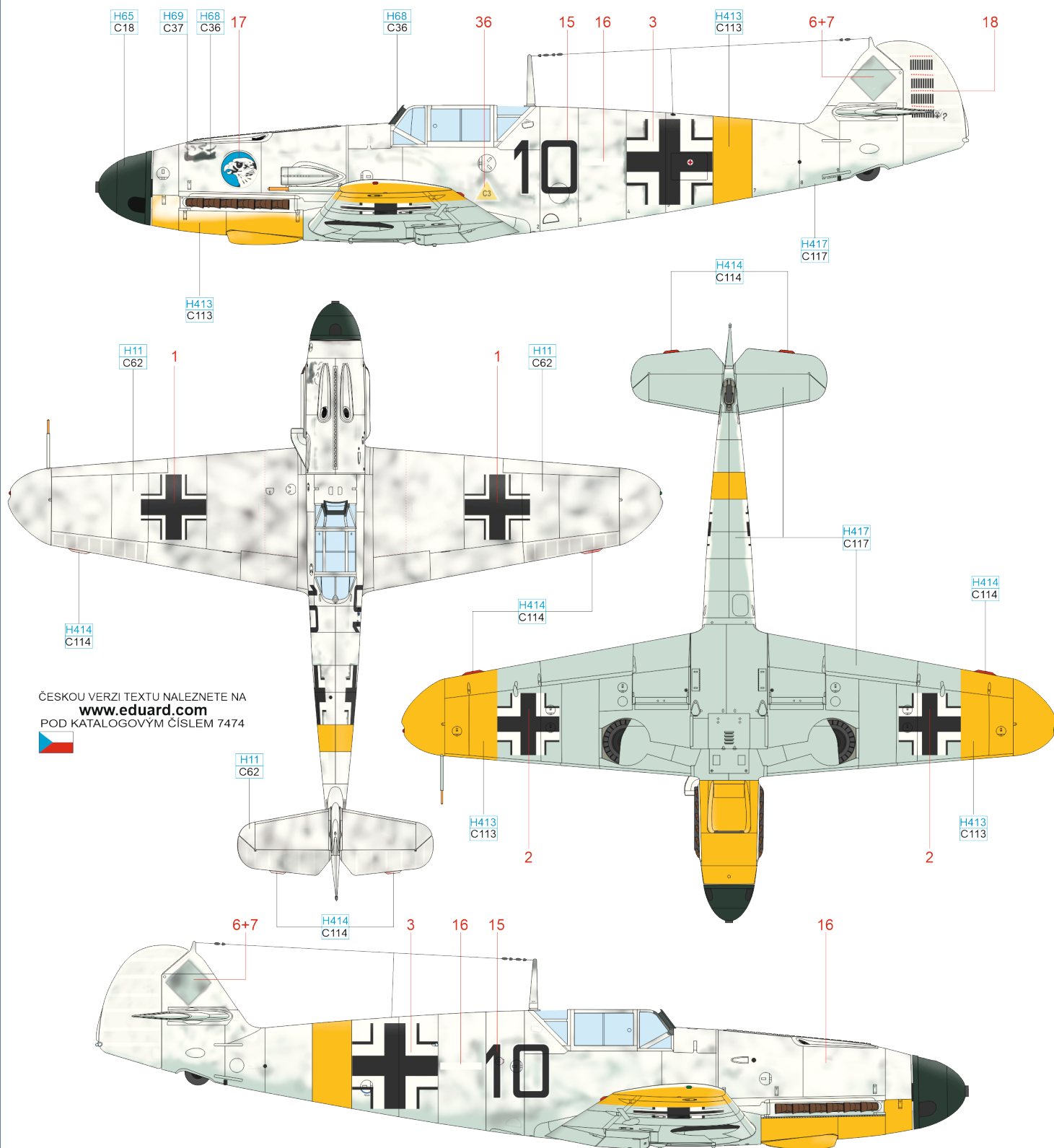

ČESKOU VERZI TEXTU NALEZNETE NA
www.eduard.com
 POD KATALOGOVÝM ČÍSLEM 7474



- | | | | | | | | | | | | | | |
|------------|---------|--------|-----------|--------|---------|--------|---------|--------|-----------|--------|-----------|--------|---------|
| FLAT WHITE | H11 C62 | RLM 76 | H417 C117 | RLM 75 | H69 C37 | RLM 74 | H68 C36 | RLM 04 | H413 C113 | RLM 23 | H414 C114 | RLM 70 | H65 C18 |
|------------|---------|--------|-----------|--------|---------|--------|---------|--------|-----------|--------|-----------|--------|---------|

D Lt. Max-Hellmuth Ostermann, 7./JG 54, Dugino, the Soviet Union, September 1941

Max-Hellmuth Ostermann was born on December 11, 1917, in Hamburg. In 1937, he joined the Luftwaffe and became a pilot. His first unit was I./ZG 1, flying the Bf 110s, and he participated in the invasion of Poland. Before the start of the French campaign, on April 7, 1940, he was transferred to I./JG 21. On May 20, 1940, he recorded his first aerial victory. After moving to the English Channel coast, I./JG 21 was renamed III./JG 54, and in April 1941, the unit saw combat in Yugoslavia. Ostermann achieved his ninth victory on April 6, 1941, over Belgrade, shooting down a Bf 109E-3 flown by Karl Štrbenek, who was killed in action. During the early stages of Operation Barbarossa, on June 23, 1941, he shot down two SB-2 bombers. By early September 1941, his aircraft, White 1, bore 25 victory markings on its tail. The sides of the fuselage were darkened with spots of RLM 02, 74, and 70 paints. The nose displayed the insignia of 7./JG 54, and below the windshield was the emblem of III./JG 54. In November 1941, Ostermann was transferred to I./JG 54, and in March 1942, he assumed command of 8./JG 54. On May 12, 1942, Ostermann became the second pilot in JG 54 to achieve 100 victories. During this engagement, he was severely wounded but managed to return to his home airfield. His luck ran out on August 9, 1942, during a confrontation with P-40s. After scoring one victory, a group of LaGG-3 fighters emerged from the clouds. Ostermann's Bf 109G-2 was hit in the cockpit and crashed behind Soviet lines near Lake Ilmen. He became the first recipient of the Knight's Cross with Oak Leaves to be killed in action.

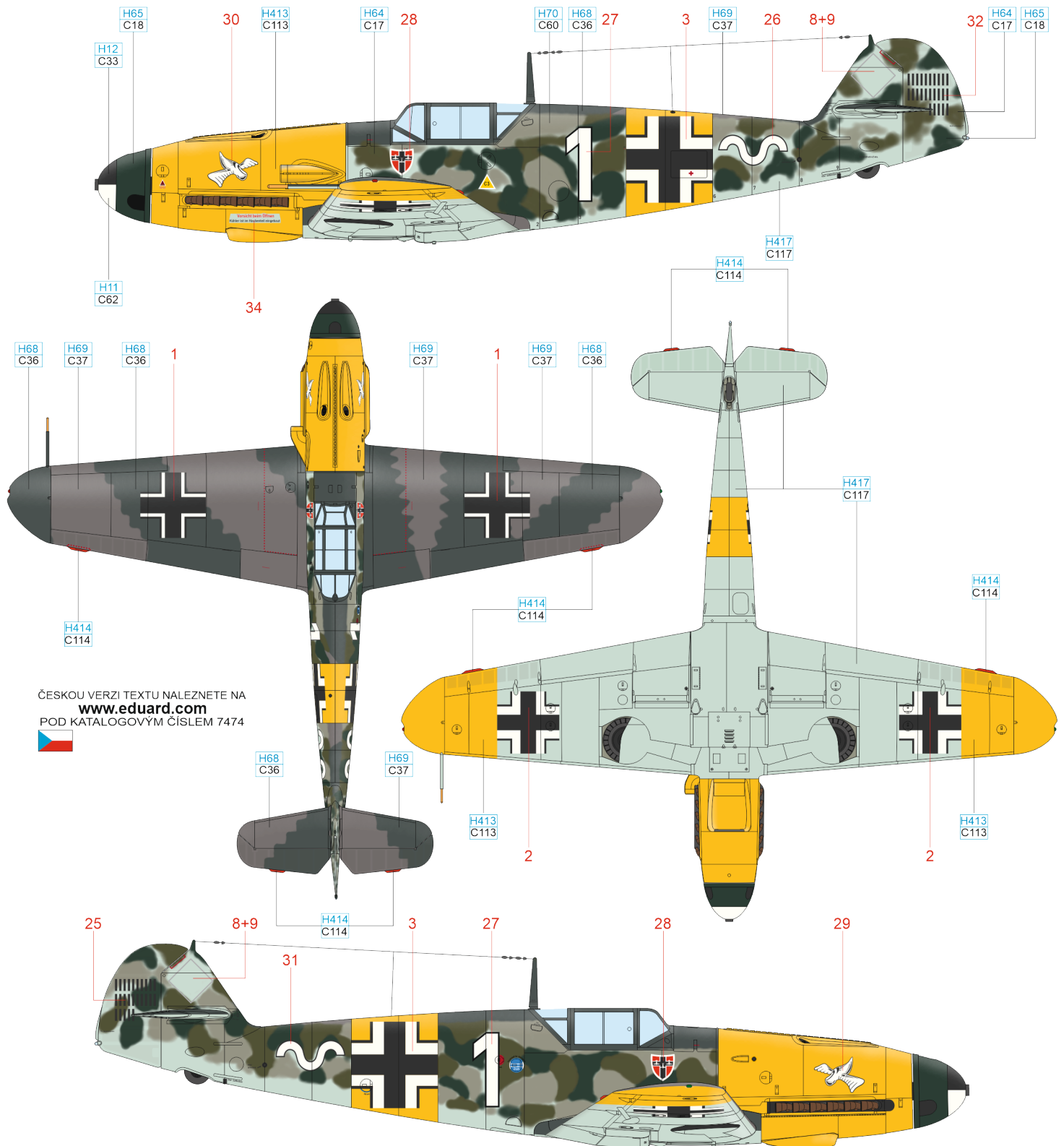

ČESKOU VERZI TEXTU NALEZNETE NA
www.eduard.com
 POD KATALOGOVÝM ČÍSLEM 7474



FLAT WHITE H11
 C62

RLM 02 H70
 C60

RLM 76 H417
 C117

RLM 75 H69
 C37

RLM 74 H68
 C36

RLM 04 H413
 C113

RLM 23 H414
 C114

RLM 71 H64
 C17

RLM 70 H65
 C18

FLAT BLACK H12
 C33

eduard

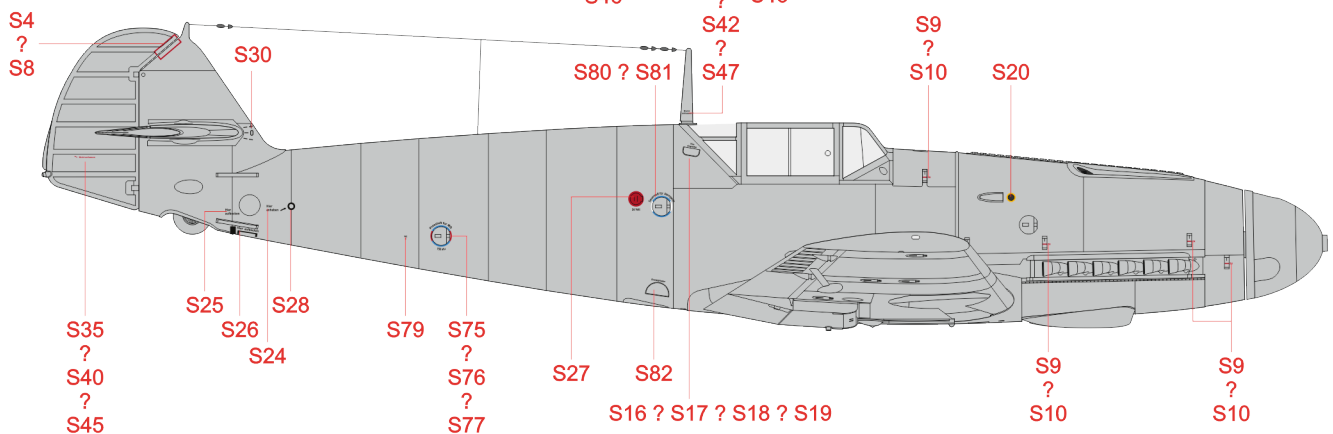
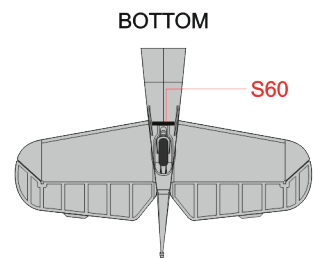
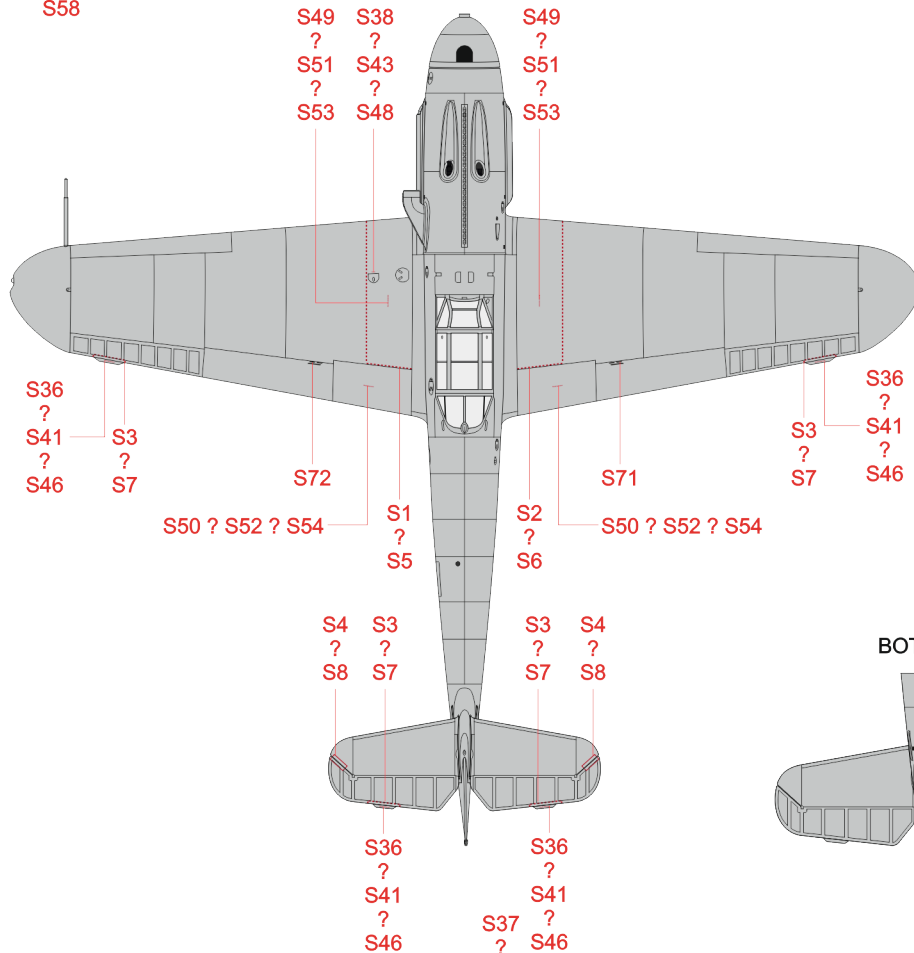
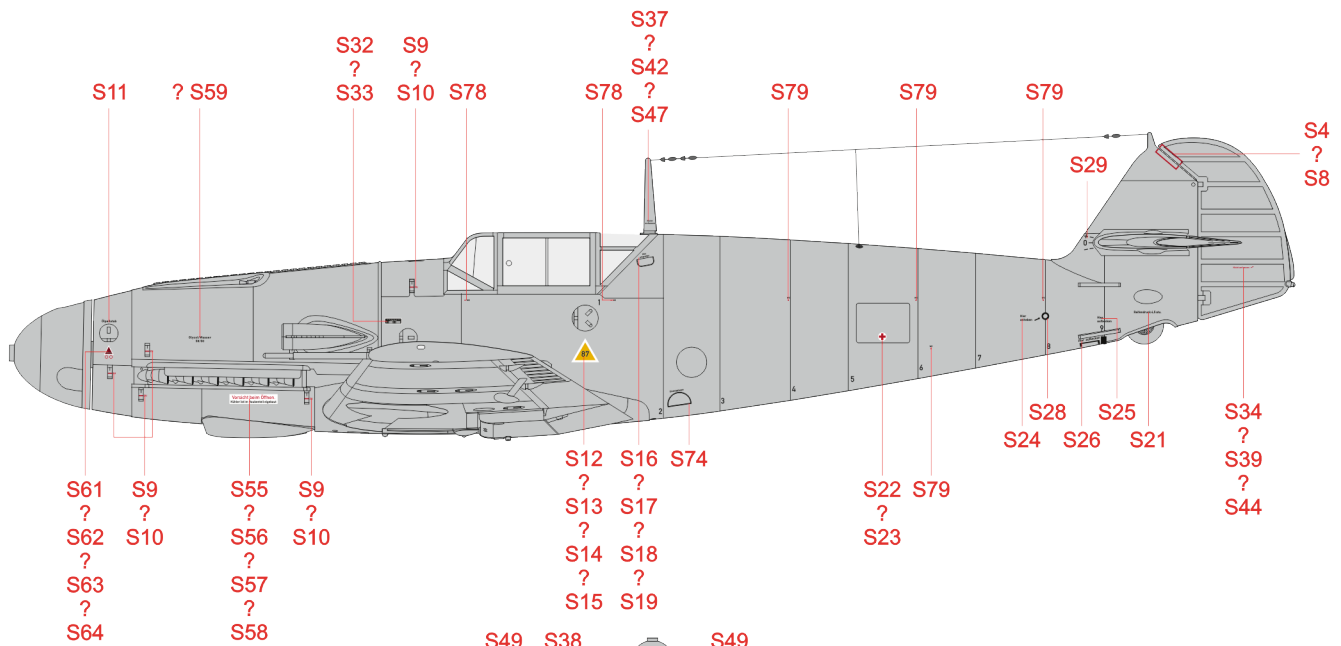

Eduard goodies for

Bf 109F-2 1/72

- 674007 Bf 109F LööK (Brassin)
- 674011 Bf 109F LööKplus (Brassin)
- 672313 Bf 109F propeller early PRINT (Brassin)
- 672315 Bf 109F gun barrels PRINT (Brassin)
- 672316 Bf 109F wheels PRINT (Brassin)
- 672317 Bf 109F undercarriage legs BRONZE (Brassin)
- 672318 Bf 109F radio compartment PRINT (Brassin)
- 672323 Bf 109F/G wheel bays angular PRINT (Brassin)
- 672325 Bf 109F/G exhaust stacks PRINT (Brassin)
- 672327 Bf 109F cockpit PRINT (Brassin)
- 672328 Bf 109F cockpit w/ early seat PRINT (Brassin)
- 672350 Bf 109F engine PRINT (Brassin)
- SIN67221 Bf 109F (Brassin)
- 3DL72018 Bf 109F SPACE (3D Decal Set)
- D72045 Bf 109F stencils (Decal Set)

674007



672323

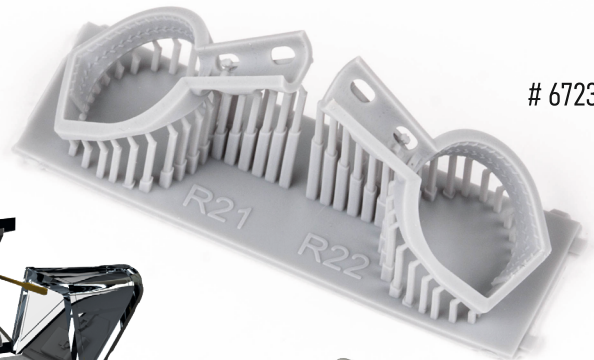

672317

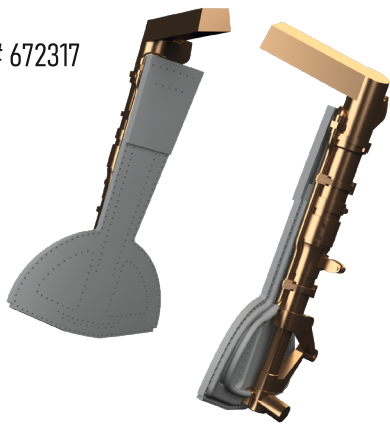

672328

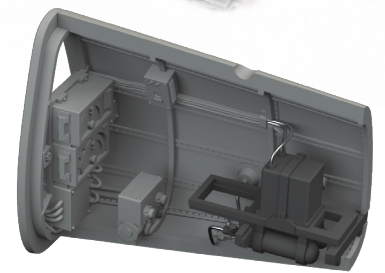
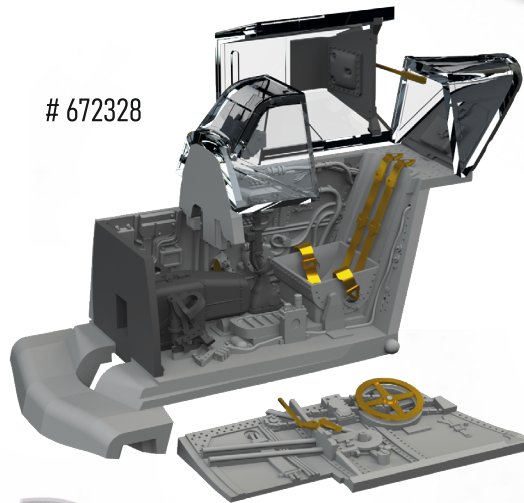

672318

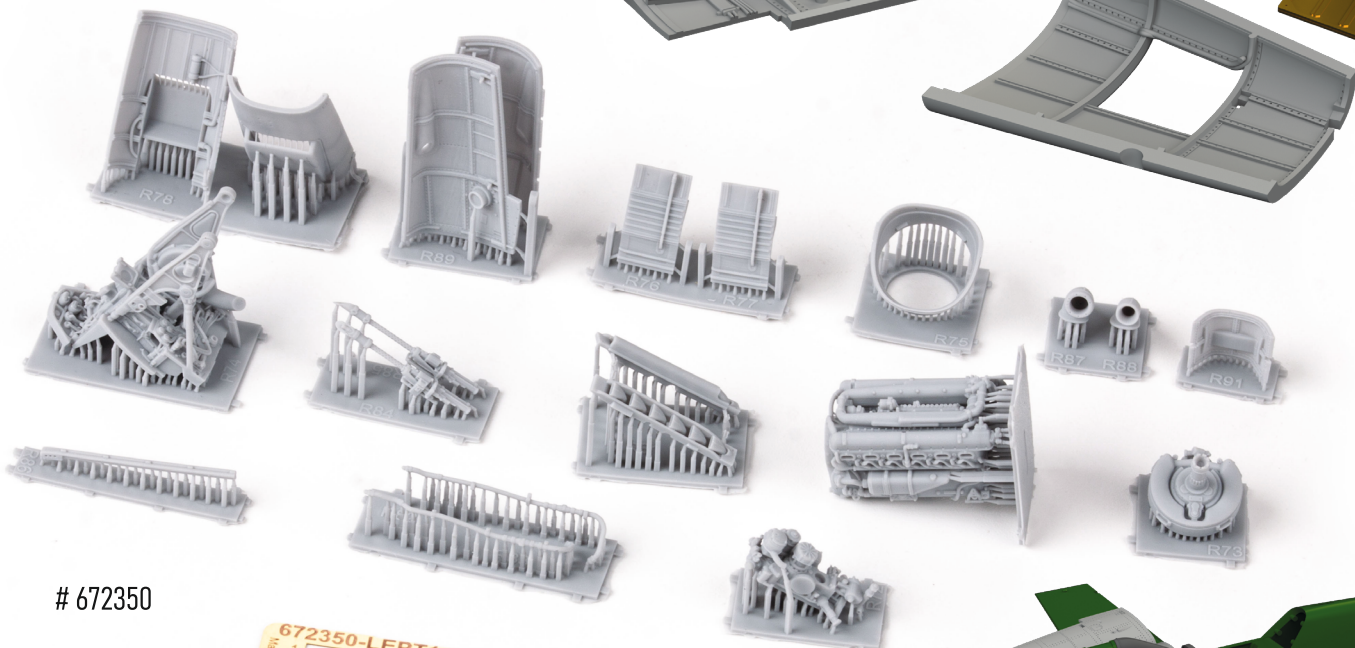

672350

