

Morane Saulnier Type N

eduard

1/48 SCALE PLASTIC KIT

ProfiPACK
edition

#8095



INTRO

The Morane Saulnier Type N was the first genuine French fighter of the Great War. It still retained much resemblance to the machinery from the pioneering aviation era, but it was one of only a few types available to help the Aéronautique Militaire in facing initial German air superiority.

The Aéropplanes Morane Saulnier company was set up by the Morane brothers, Léon and Robert, together with a friend, Raymond Saulnier, in the same year as the rival Aéropplanes Deperdussin (later known as S.P.A.D) was established in 1911. Both companies started building pre-war racing airplanes, focusing mainly on monoplane designs. In fact, the Morane Saulnier company built just a handful of biplanes during its existence. As the need for armed fighters became evident from an early stage of the Great War, the designers experimented with the installation of various weapons on what were, until then, unarmed airplanes. On the French side, two men were instrumental in the development of this concept: Charles de Tricornot de Rose, the first pilot to earn military wings in France, and Roland Garros. De Rose was very determined to win over the sceptics by demonstrating that aircraft could locate, pursue and destroy an enemy counterpart. However, at the time, the first dedicated French pursuit squadron, MS 12, which de Rose formed, used only four-round carbines operated by observers of the two seat Morane Saulnier Type L. The need for a dedicated fighter was increasingly obvious...

First of the French Fighters

Both men, de Rose and Garros, had similar ideas with respect to what made a good fighter: a fast aircraft outfitted with a machine gun firing through the propeller arc. The need to protect the propeller from the rounds being fired was solved by metal deflector wedges fitted to the propeller blades. The solution was not ideal, due to vibrations of the propeller and engine caused by the impact of the bullets. But Garros himself proved the system viable, when he shot down three enemy aircraft during April 1915 flying his modified parasol Morane Saulnier Type L. Meanwhile, he also contributed to the development of the Morane Saulnier Type N, which he personally displayed publicly at a flying meet at Aspern, Vienna in June 1914. The design bore a family resemblance to the earlier Types G and H and was powered by an 80hp Gnome rotary engine hidden behind a large spinner. The forward firing Hotchkiss 7.9mm machine gun was placed on the top of the front fuselage and the propeller was fitted with the deflector wedges.

When a single Type N appeared at the front flown by Eugène Gilbert in April 1915 it became the first dedicated French fighter in active service. A small production series was soon ordered for the Aéronautique Militaire, under the official designation MoS.6.C1. But the Type N was popularly known as "Monocoque", although it was not of monocoque construction.

Too Nimble, Too Hard to Handle

The Type N was a well streamlined aircraft, because of, among other things, the large spinner, giving it the appearance of a bullet. That nickname was later used by British pilots, who also flew the Type N, slightly modified for the Royal Flying Corps. The spinner, nicknamed "Casserole" in French (the Pot), caused the engine to overheat and its removal, as it turned out, did not affect the aerodynamics significantly. Consequently, many of the remaining aircraft were flown without the 'Casserole'. The Morane Saulnier Type N was everything but a smooth handling aircraft with its very stiff lateral controls, caused by the obsolete wing warping system used instead of ailerons. The pitch and yaw controls were also troublesome, because of high sensitivity of the tail surfaces. Additionally, the monoplane design required a high landing speed - too high for less experienced pilots. But, it was also very nimble. According to the British pilot Cecil Lewis, nobody taller than 5 feet 6 inches (1.67 m) would fit comfortably in the cockpit. In any case, until the Nieuport 11 appeared in service, the Type N was the best fighter the French could use against the Fokker 'Eindeckers'. It is quite interesting in this context that Fokker acquired a Morane Saulnier Type H in 1913, which led to the creation of his own line of monoplanes, culminating with the E-type, the famous 'Eindecker'. This airplane, combined with the introduction of a synchronization unit for the machine guns allowing fire through the propeller arc without deflectors gave rise to the dominance of German fighters from mid-1915 to early 1916, a time span known as the 'Fokker Scourge' period.

In Foreign Service

The British Royal Flying Corps received 27 Type N aircraft in 1916, assigning them to three Squadrons (1st, 3rd and 60th). Their armament was changed to a single 7.7mm Lewis gun. The Imperial Russian Air Service was the second foreign user with an unknown number (may be only one) of the Type N. Altogether, there were just some 49 Type N produced. The introduction of the Nieuport 11 in frontline units in January 1916 spelled the end of the Morane Saulnier Type N development, although several improved Type I aircraft, powered by the 110hp Le Rhône engine, were produced in 1916 as the swansong of the type. Only a handful of them remained in France, most of them went to Russia and some to the RFC. Among the French aces flying the 'Monocoque' were the likes of Jean Marie Dominique Navarre (total of eleven victories), Adolphe Pégoud (more than six victories) and Eugène Gilbert (five victories). Roland Garros never flew a Type N in combat.

ATTENTION



UPOZORNĚNÍ



ACHTUNG



ATTENTION



注意



Carefully read instruction sheet before assembling. When you use glue or paint, do not use near open flame and use in well ventilated room. Keep out of reach of small children. Children must not be allowed to suck any part, or pull vinyl bag over the head.



Před započítím stavby si pečlivě prostudujte stavební návod. Při používání barev a lepidel pracujte v dobře větrané místnosti. Lepidla ani barvy nepoužívejte v blízkosti otevřeného ohně. Model není určen malým dětem, mohlo by dojít k požití drobných dílů.

INSTRUCTION SIGNS

* INSTR. SYMBOLY

* INSTRUKTION

* SINNBILDEN

* SYMBOLES

* 記号の説明

OPTIONAL
VOLBABEND
OHNOUTSAND
BROUSITOPEN HOLE
VYVRTAT OTVORSYMMETRICAL ASSEMBLY
SYMETRICKÁ MONTÁŽREMOVE
ODRŽNOUTREVERSE SIDE
OTOCITAPPLY EDUARD MASK
AND PAINT
POUŽIT EDUARD MASK
NABARVIT

PARTS



DÍLY



TEILE



PIÈCES



部品

PLASTIC PARTS

A>

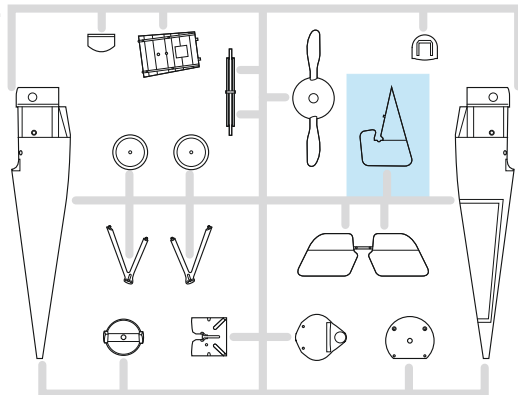

X>

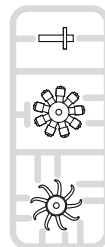
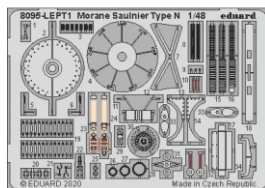
PE - PHOTO ETCHED
DETAIL PARTS

B>

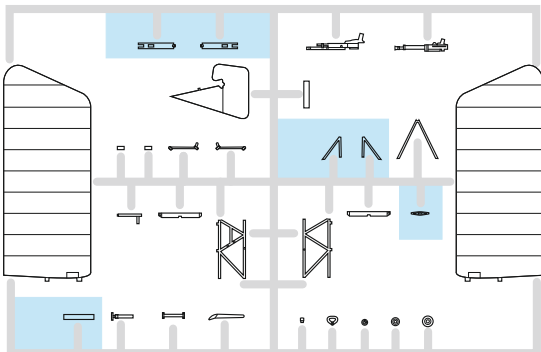

FILM

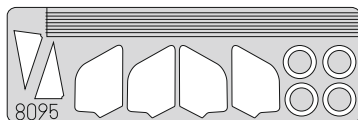
eduard
MASK

-Parts not for use. -Teile werden nicht verwendet. -Pièces à ne pas utiliser. -Tyto díly nepoužívejte při stavbě. - 使用しない部品

COLOURS



BARVY



FARBEN



PEINTURE



色

GSI Colors (GUNZE)		MISSION MODELS	
AQUEOUS	Mr.COLOR	PAINTS	
[H6]	[C5]	[MMP-048]	BLUE
[H11]	[C62]	[MMP-001]	FLAT WHITE
[H12]	[C33]	[MMP-047]	FLAT BLACK
[H13]	[C3]	[MMP-003]	FLAT RED
[H37]	[C43]		WOOD BROWN
[H47]	[C41]	[MMP-012]	RED BROWN
[H51]	[C11]	[MMP-063]	LIGHT GULL GRAY
[H71]	[C21]	[MMP-076]	MIDDLE STONE

GSI Colors (GUNZE)		MISSION MODELS	
AQUEOUS	Mr.COLOR	PAINTS	
[H85]	[C45]		SAIL COLOR
[H321]	[C321]	[MMP-086]	LIGHT BROWN
Mr.METAL COLOR		METALLICS	
[MC214]		[MMM-001]	DARK IRON
[MC218]		[MMM-003]	ALUMINIUM
[MC219]		[MMM-009]	BRASS
Mr.COLOR SUPER METALLIC		METALLICS	
[SM201]		[MMC-001]	SUPER FINE SILVER

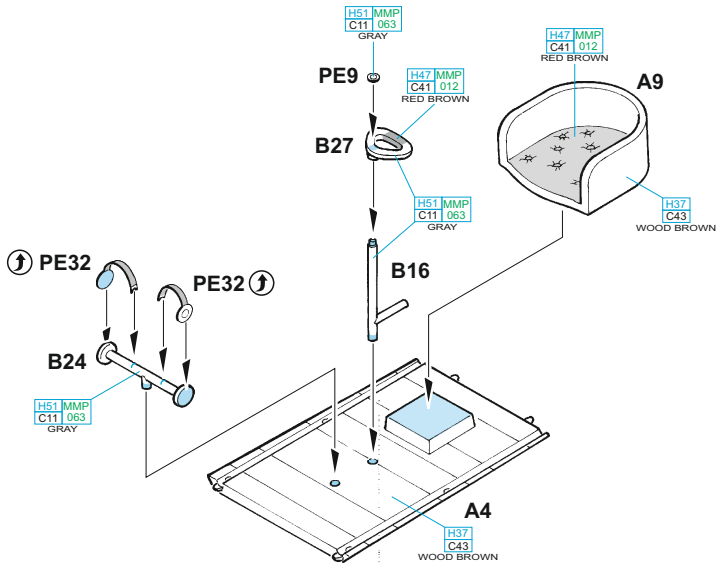
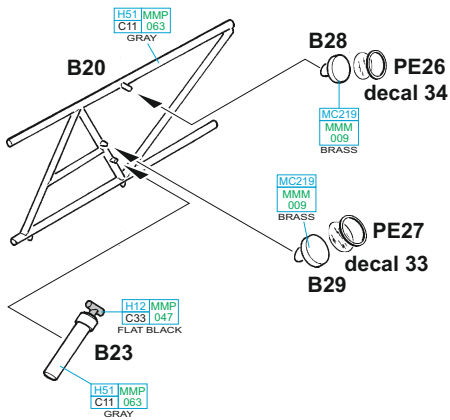
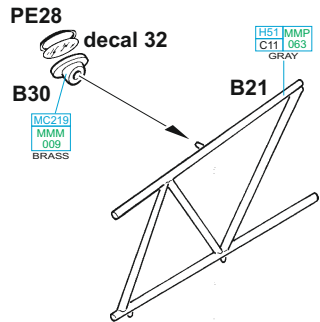
A**B****C**

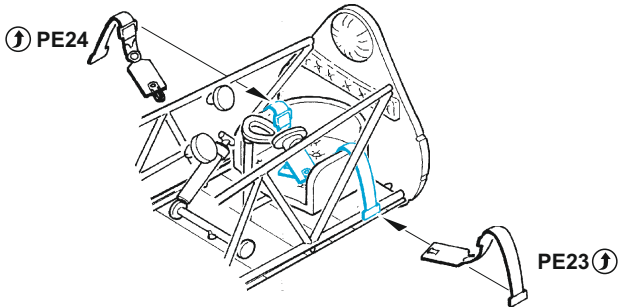
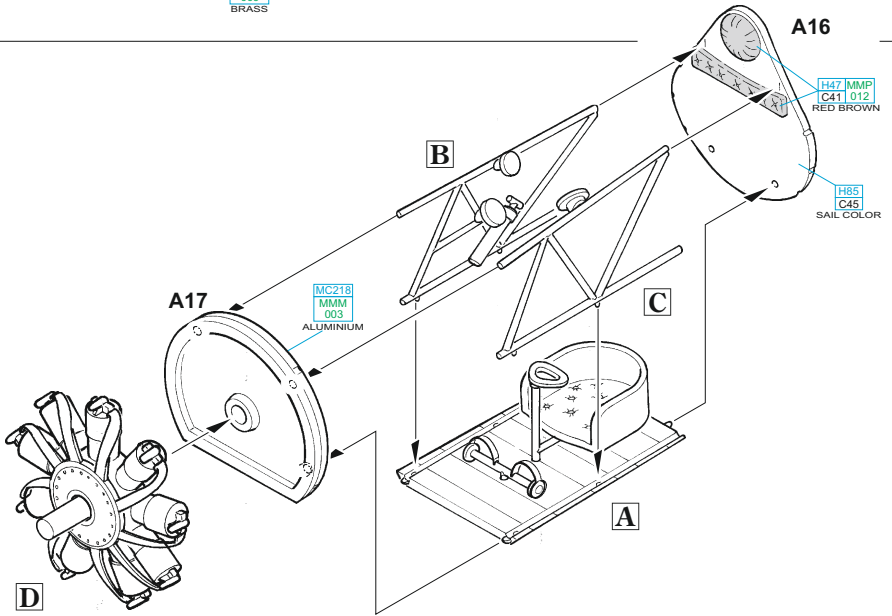
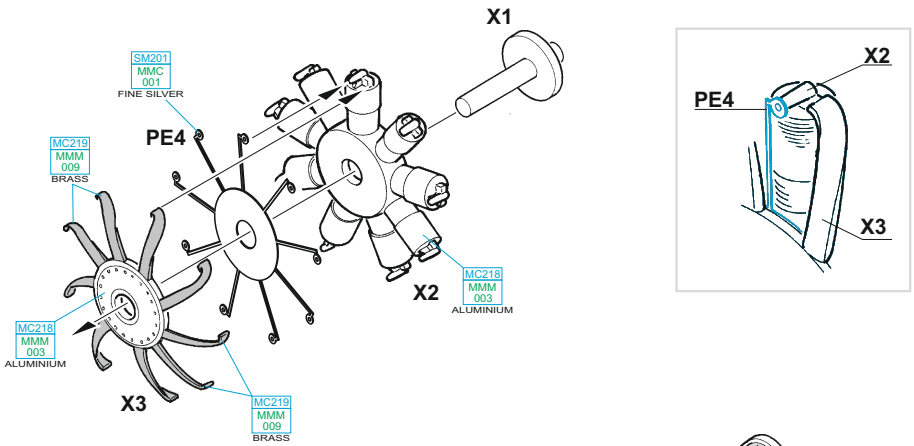
D

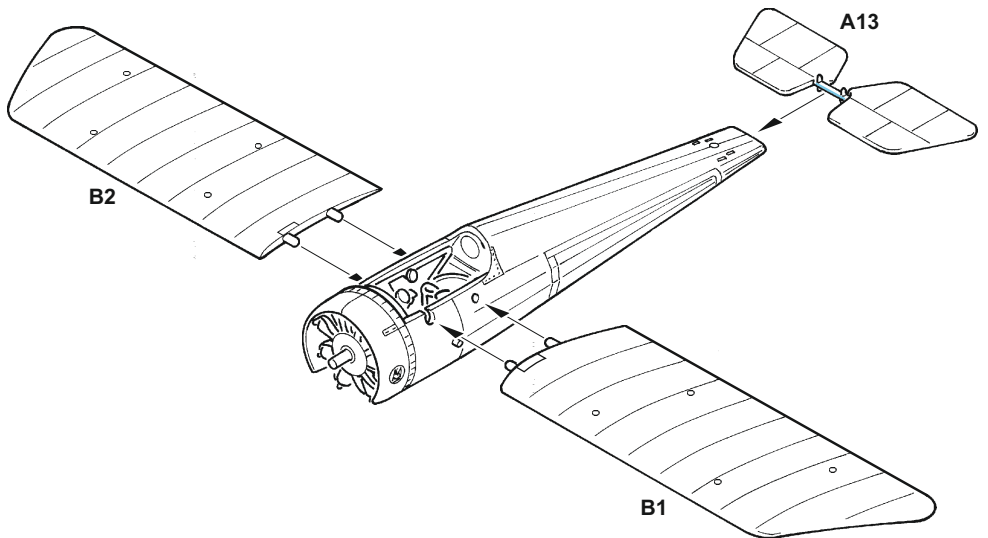
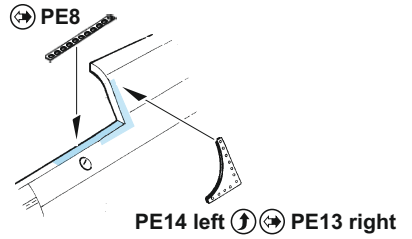
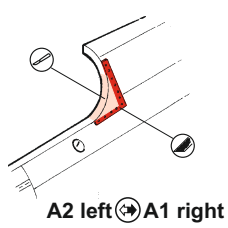
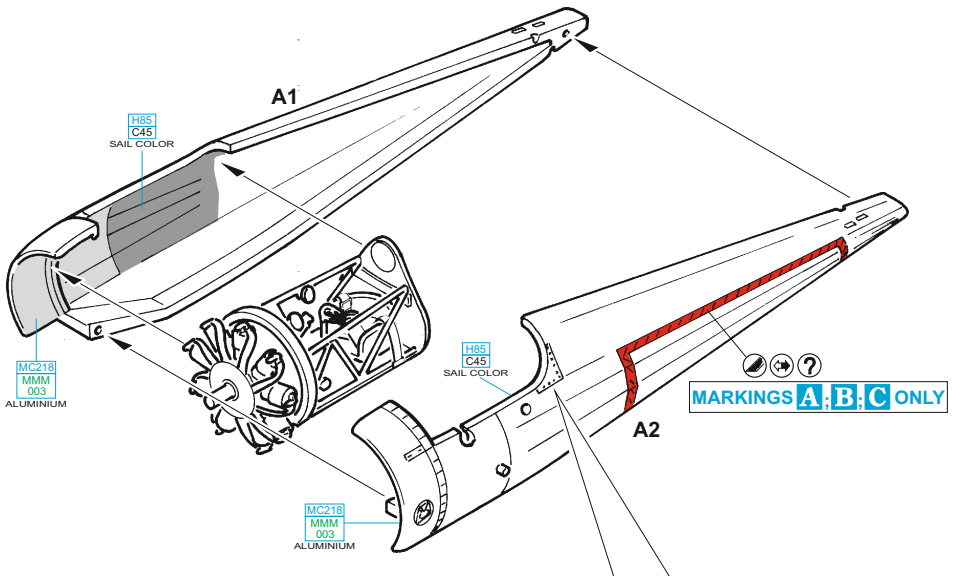

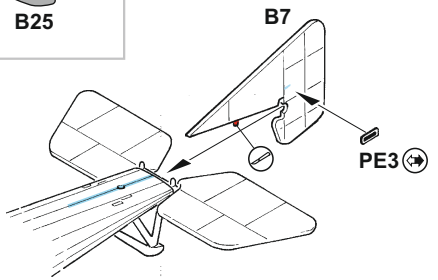
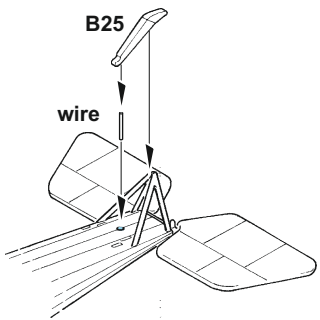
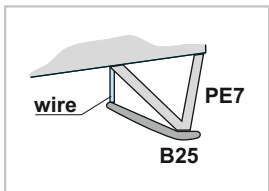
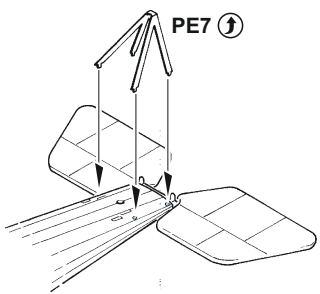
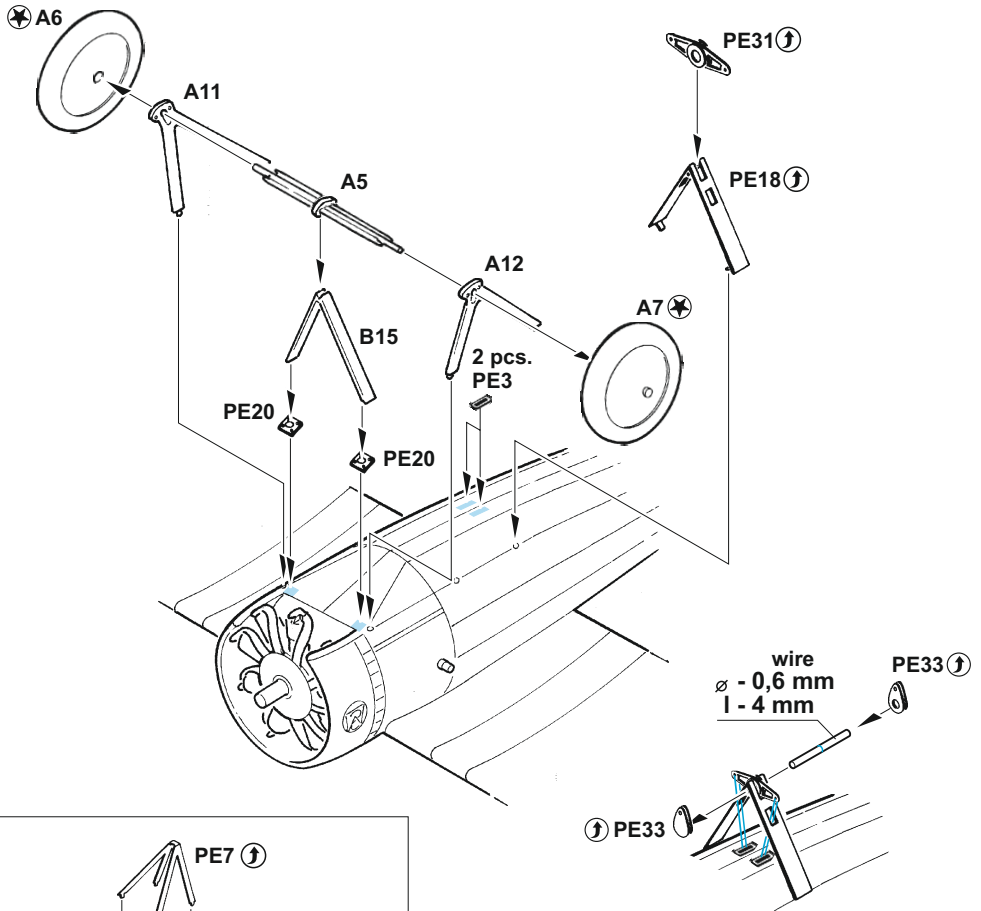

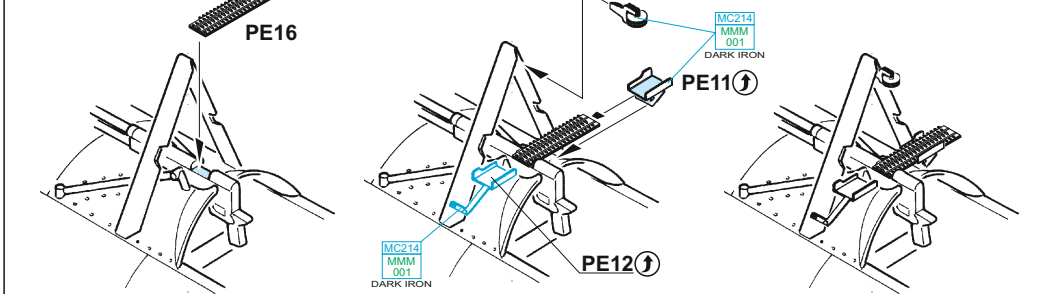
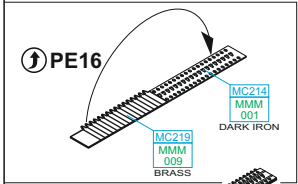
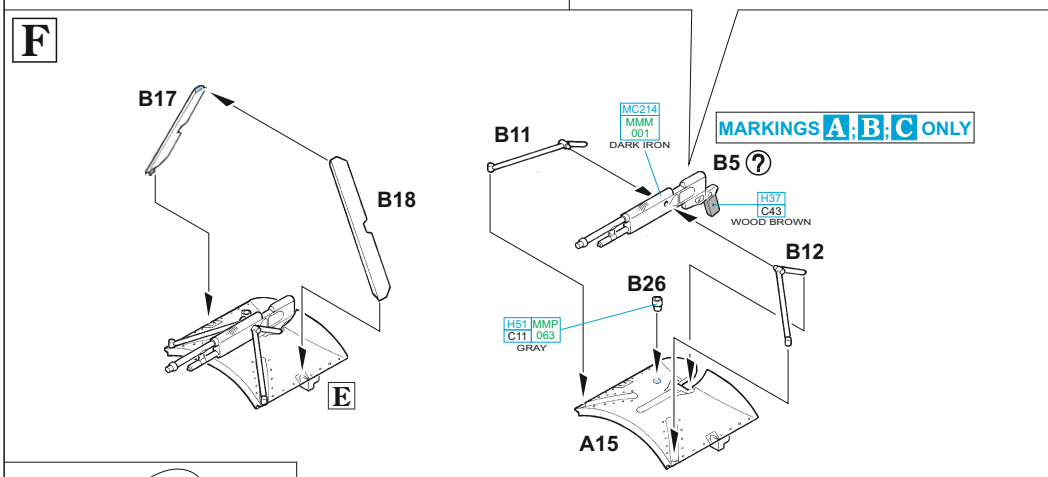
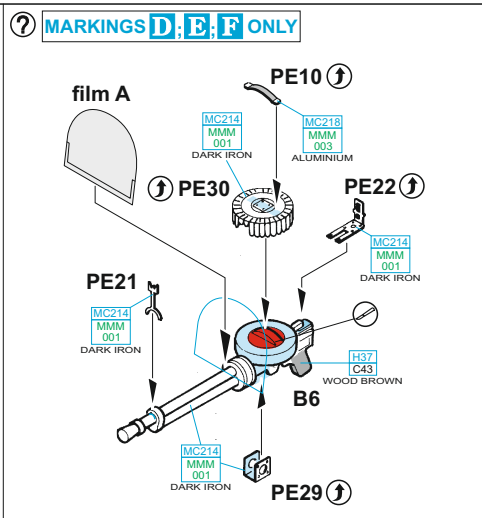
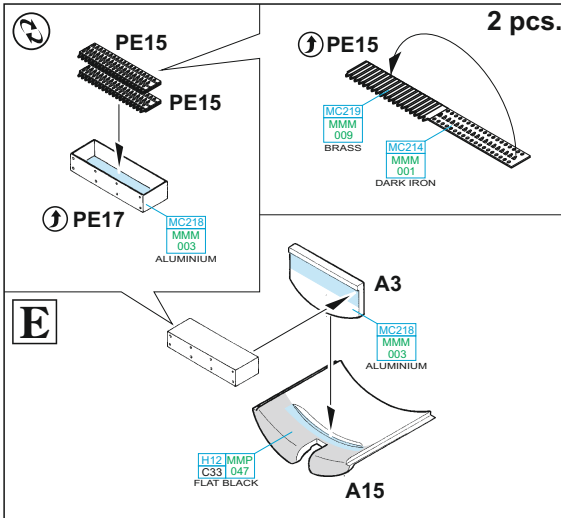

PE11, 12, 16 - MARKINGS A, B, C ONLY

G

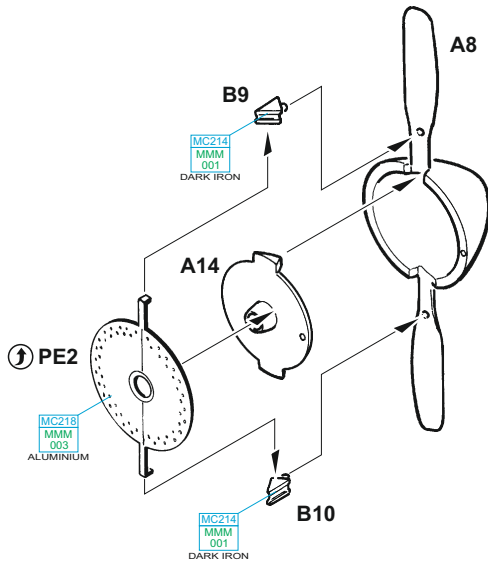

MARKINGS A, B, C ONLY

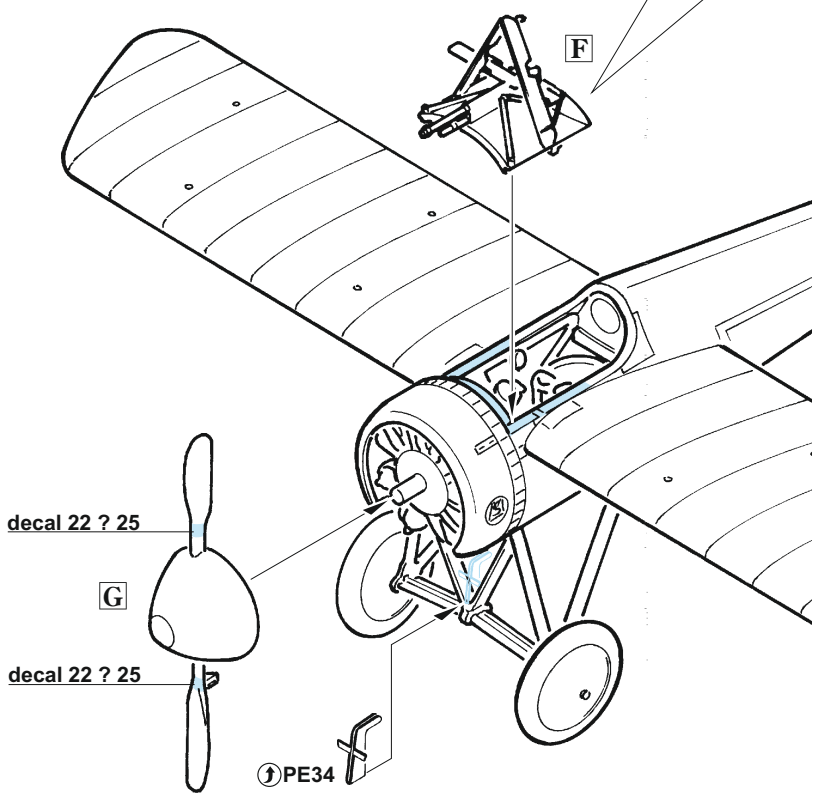
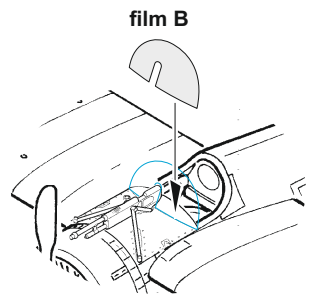

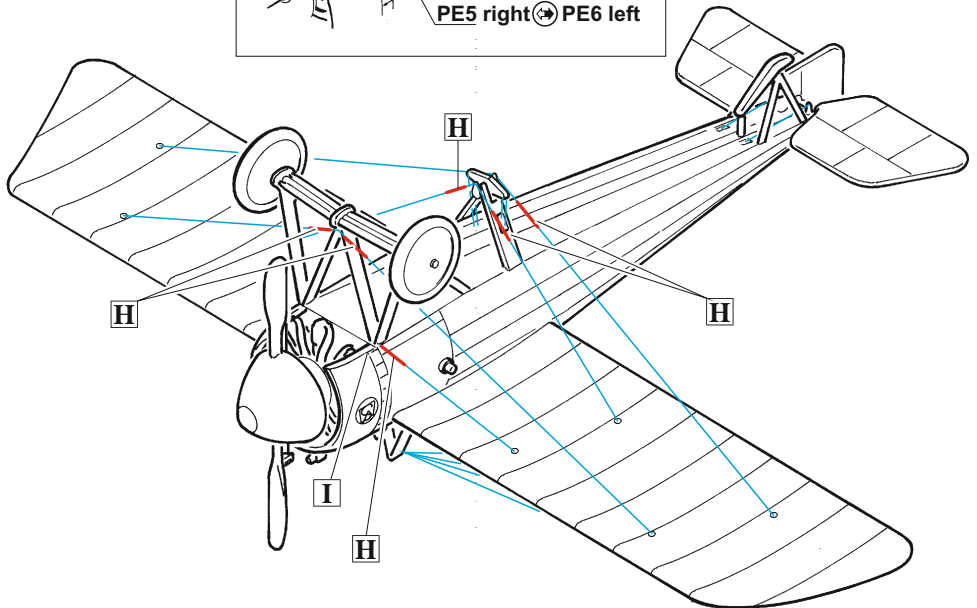
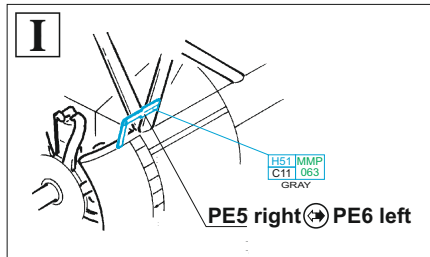
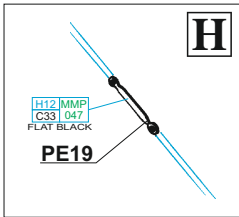
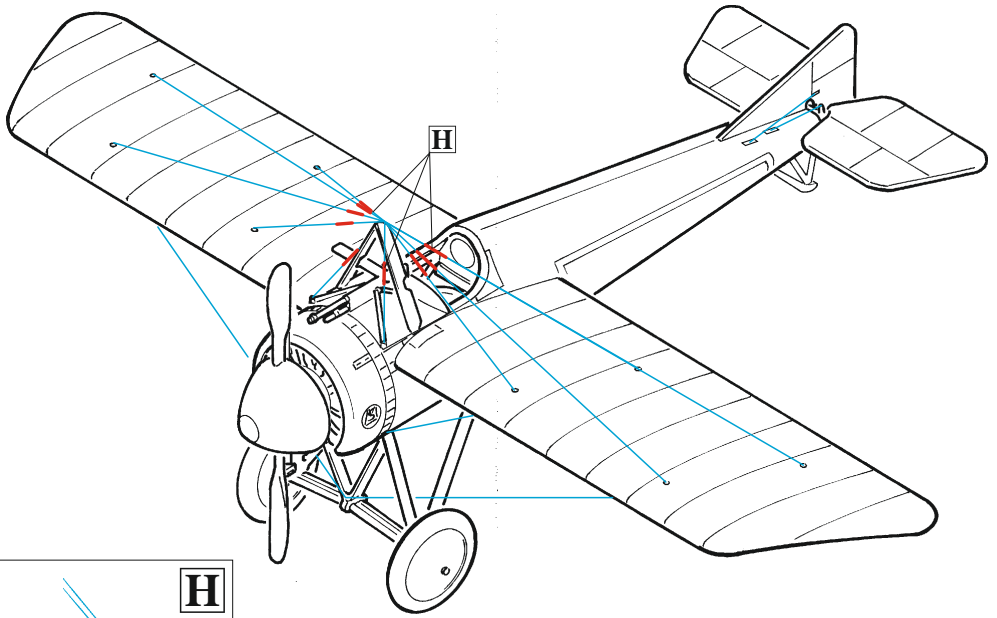

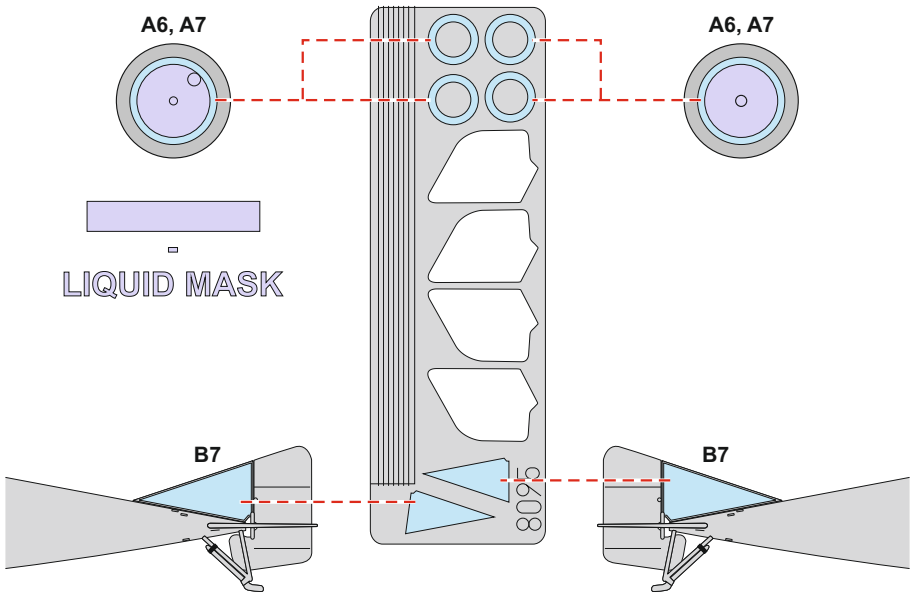
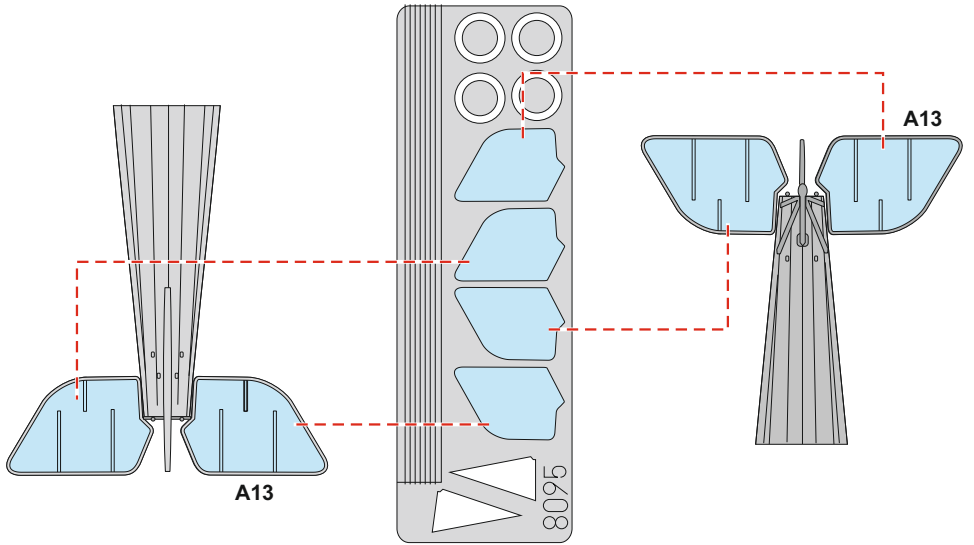

A MS398, flown by Adj. Jean Marie Dominique Navarre, Escadrille MS 12, France, October 1915

Jean Navarre, a future ace with twelve confirmed air victories flying the Morane Saulnier Type N MS398, came upon a German LVG C II over Chateau-Thierry on October 26th, 1915. The German gunner fired off some 300 rounds with no effect in the combat that ensued. Navarre required a mere eight rounds before damaging the engine of the German reconnaissance aircraft. After the latter set down in French territory, Navarre landed next to it, and the event gave rise to a photo op. The Germans congratulated Navarre on his victory, and were taken prisoner. Not long thereafter, Navarre was transferred to Escadrille N 67, equipped with the Nieuport aircraft. S/Lt. Navarre suffered serious head injuries on June 17th, 1916 in combat, and this cut short his combat career. He died on July 10th, 1919, while practising for a parade fly-by, which was to have taken place on July 14th of the same year.

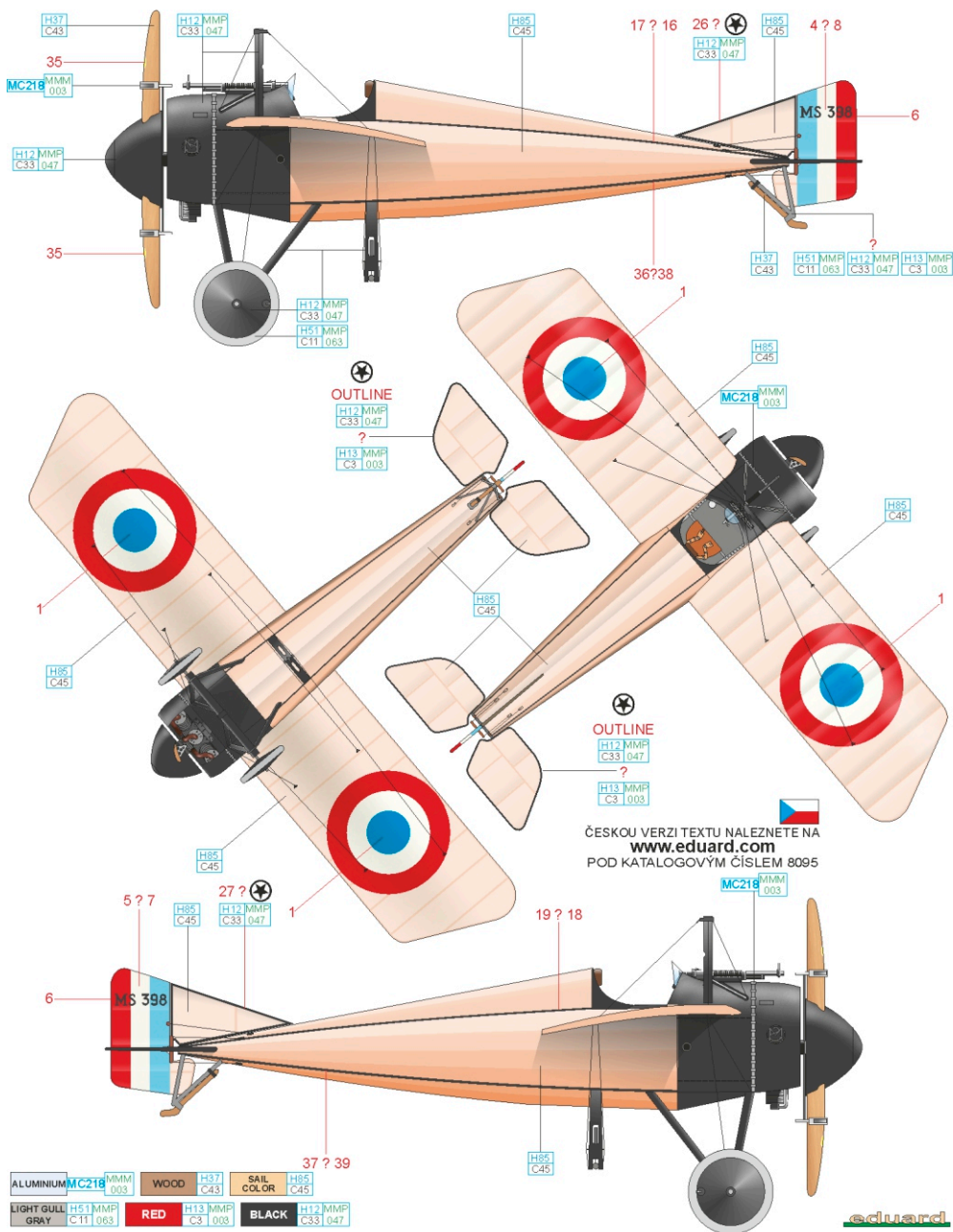

B MS394, probably from Escadrille MS.12, France, 1915

Escadrille 12 was formed in 1912, and is known for its use of Nieuport aircraft over the course of the First World War. The unit utilized these aircraft from the start of the war, and, according to French Air Force protocols, was designated N 12 ('N' for Nieuport). On February 28th, 1915, it re-equipped with the Morane Saulnier Type N, and the unit's designation followed suite, being changed to MS 12. These aircraft were not particularly liked, and the pilots gladly traded them in for Nieuport 11s in September 1915. The unit designation reverted to N 12. Initially, the Morane Saulnier Type N flew with the front of the aircraft in black. The same can be said of aircraft that were coming out of licensed production at Pfalz, and for this reason, the Morane aircraft were repainted red.

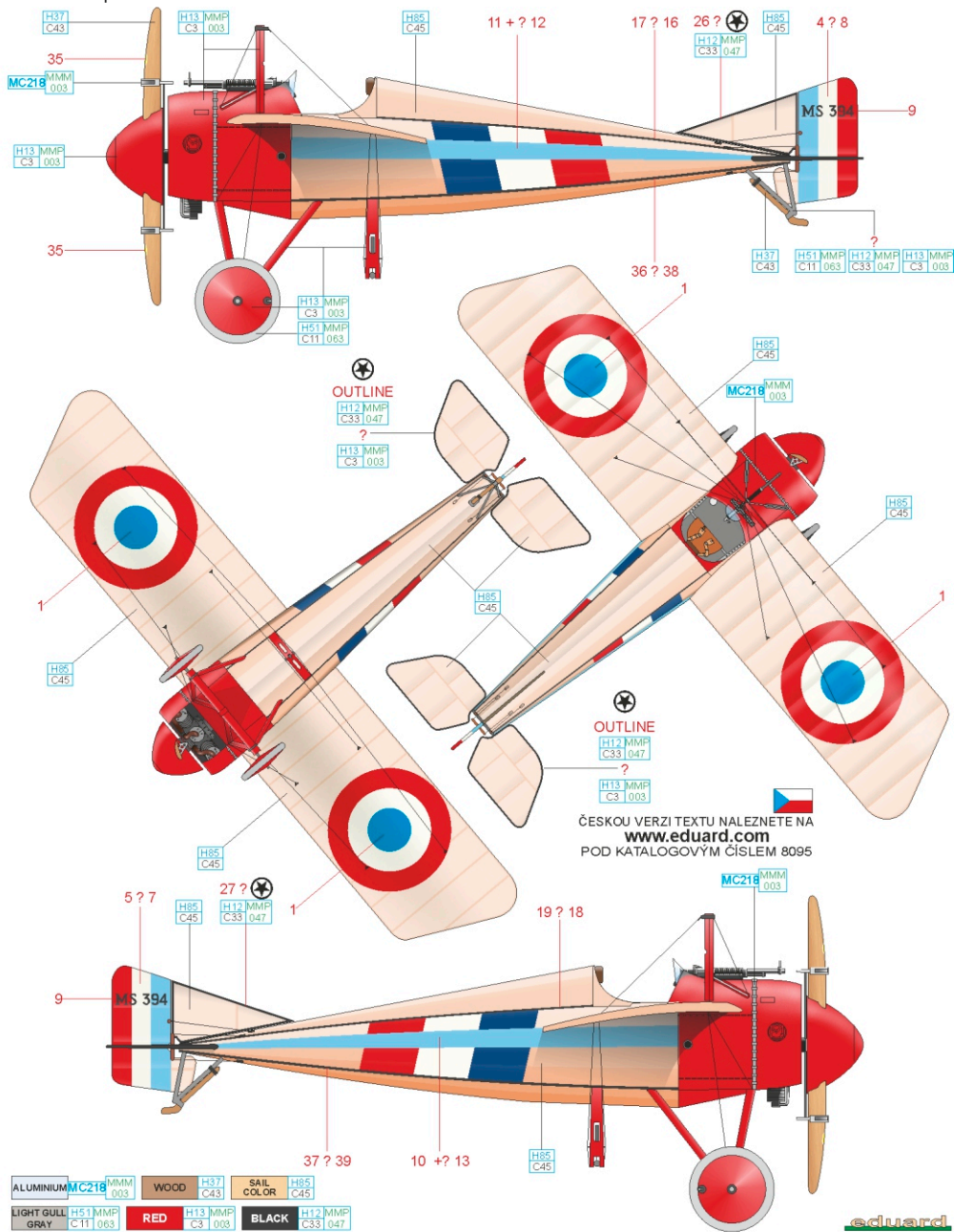

C flown by Sergt. Jean Chaput, Escadrille N 31, France, 1916

A native of Paris, Jean Chaput joined the army in 1913 at the age of twenty. At first, he served as a infantryman and to the Air Force transferred in 1914. Initially, he flew with Escadrille 28, where he would attain his first kill, when he forced down a Fokker Eindecker on June 12th, 1915. He was wounded three days later, and after recuperating, he returned to active duty in January 1916, this time with Escadrille N 31, armed with a mix of Nieuport and Morane Saulnier aircraft. Over the course of the war, he would be seriously wounded several more times and he claimed a total of sixteen victories. His life ended in May 1918, while in the cockpit of a SPAD XIII, was shot down by Hermann Becker of Jasta 12, near Montdidier.

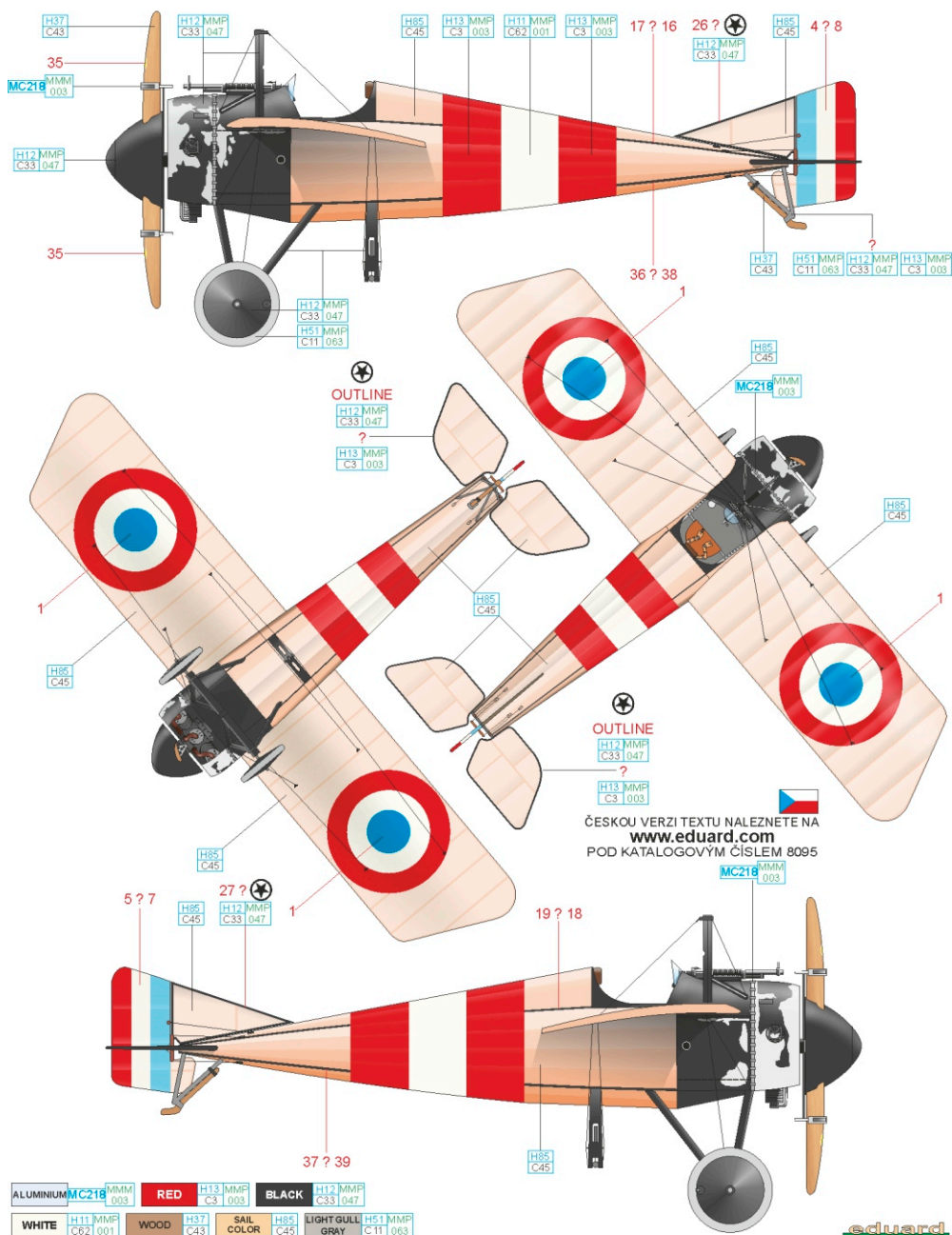

F A.178, flown by Lt. Tone H. P. Bayetto, No. 24 Squadron RFC, France, June 1916

As with the preceding aircraft, this example served with the French Air Force, and was transferred to the British RFC at the beginning of June 1916, assigned to No. 3 Squadron. In July 1916, when the Battle for the Somme was in its beginning phases, it was lent to No. 24 Squadron, where it was flown by Lt. Tone Hippolyte Paul Bayetto. After it was returned to No. 3 Squadron, it made its way to No. 60 Squadron, and in September it was disassembled and was shipped to Great Britain.

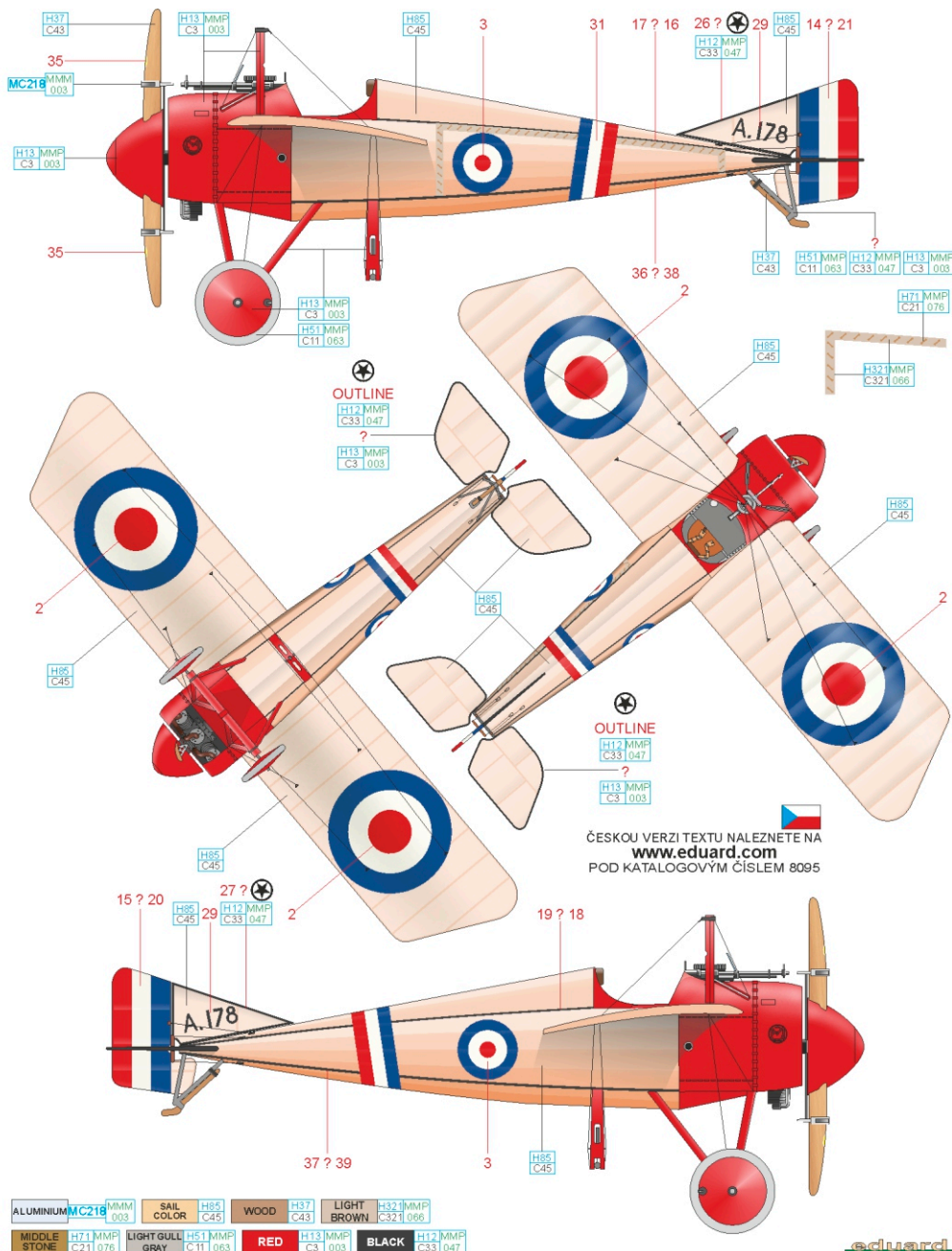

ČESKOU VERZI TEXTU NALEZNETE NA
www.eduard.com
 POD KATALOGOVÝM ČÍSLEM 8095

ALUMINIUM	MC218	MMM	003	SAIL COLOR	H85	C45	WOOD	H37	C43	LIGHT BROWN	H32	MMP	C32	1	006				
MIDDLE STONE	H71	MMP	C21	076	LIGHT GULL GRAY	H51	MMP	C11	063	RED	H13	MMP	C3	003	BLACK	H12	MMP	C33	047

eduard